

# *LINKS<sup>2</sup>*

**RETROFIT  
INSTRUCTIONS FOR  
GSTC / SETC / NHTC /  
NHDI / NHSC**

**Installation Manual**

## PROPRIETARY NOTICE

This document and the information disclosed herein are proprietary data of WALTER MEIER LTD. Neither this document nor the information contained herein shall be reproduced used, or disclosed to others without the written authorization of WALTER MEIER LTD., except to the extent required for installation or maintenance of recipient's equipment. All references to the NORTEC name should be taken as referring to WALTER MEIER LTD.



## LIABILITY NOTICE

NORTEC does not accept any liability for installations of humidity equipment installed by unqualified personnel or the use of parts/components/equipment that are not authorized or approved by NORTEC.

## COPYRIGHT NOTICE

Copyright 2008, WALTER MEIER LTD. All rights reserved.

## RECORD OF REVISIONS

For each revision, put the revised pages in your manual and discard the superseded pages. Write the revision number and revision date, date put in manual, and the incorporator's initials in the applicable columns on the Record of Revisions.

Revision Number	Revision Date	Date Put In Manual	By	Revision Number	Revision Date	Date Put In Manual	By

## TABLE OF CONTENTS

Subject	Page
<b>10-00 LINKS 2 - FIELD INSTALLATION OF A SE-50</b>	
1. FIELD INSTALLATION OF A SE-50 SERIES HUMIDIFIER WITH A LINKS 2 REMOTE PACKAGE . . . . .	2
A. INSTALLATION . . . . .	2
B. CONFIGURING THE HUMIDIFIERS . . . . .	2
<b>10-10 LINKS 2 - FIELD CONVERSION OF A GSTC/SETC</b>	
1. FIELD INSTALLATION OF A GSTC/SETC SERIES HUMIDIFIER WITH A LINKS 2 REMOTE PACKAGE. . . . .	2
A. WIRING THE NORTEC LINKS 2 MODULE . . . . .	2
B. MOUNTING THE LINKS 2 ASSEMBLY . . . . .	3
C. CONFIGURING THE HUMIDIFIERS . . . . .	4
<b>10-20 LINKS 2 - FIELD CONVERSION OF A NHTC</b>	
1. FIELD INSTALLATION OF A NHTC SERIES HUMIDIFIER WITH A LINKS 2 REMOTE PACKAGE . . . . .	2
A. MOUNT THE LINKS 2 ASSEMBLY . . . . .	2
B. CONFIGURING THE HUMIDIFIERS . . . . .	4
<b>10-30 LINKS 2 - FIELD CONVERSION OF A NHD/SC</b>	
1. FIELD INSTALLATION OF A NHD/SC SERIES HUMIDIFIER WITH A LINKS 2 REMOTE PACKAGE. . . . .	2
A. MOUNT THE LINKS 2 ASSEMBLY . . . . .	2
B. WIRING THE NORTEC LINKS 2 MODULE . . . . .	3

### WARRANTY

## LIST OF FIGURES

Figure	Page
<b>10-10 LINKS 2 - FIELD CONVERSION OF A GSTC/SETC</b>	
Figure 1. Component Identification . . . . .	2
Figure 2. LINKs2 Bracket Placement . . . . .	3
<b>10-20 LINKS 2 - FIELD CONVERSION OF A NHTC</b>	
Figure 1. Component Identification . . . . .	2
Figure 2. Hook Position . . . . .	3
Figure 3. Assembly Mounting Location . . . . .	3
<b>10-30 LINKS 2 - FIELD CONVERSION OF A NHD/SC</b>	
Figure 1. Component Identification . . . . .	2
Figure 2. LINKS 2 Bracket Placement. . . . .	3
Figure 3. NHD/SC LINKS 2 Slave Installation . . . . .	4

**10-00**  
**LINKS 2 -**  
**FIELD INSTALLATION**  
**OF A SE-50**

## **(1) FIELD INSTALLATION OF A SE-50 SERIES NORTEC LINKS 2 REMOTE PACKAGE**

### **A. STEP 1 - INSTALLATION**

- (1) Mount the LINKS 2 remote package in a convenient location. Note that the remote package does not need to be mounted in close proximity to the humidifier.
- (2) Connect power to the 24VAC and GND terminals of the LINKS 2 terminal strip. This may be done in two ways:
  - (a) A 120VAC to 24VAC plug-in transformer with screw terminals on the secondary side has been supplied with this kit. Wire the transformer to the 24VAC and GND terminals on the LINKS 2 terminal strip.
  - (b) Connect power from the humidifier terminal strip (see wiring diagram for details).

#### **NOTE on 2(b)**

Power to LINKS 2 module will be lost when the humidifier is switched off.

- (3) Connect the slave humidifiers (if applicable) to the Nortec Links Module. A twisted pair cable should be used so that the Net + terminal on the Links module should connect to the first pin (bottom-most pin) of the TB3 connector. The Net – terminal on the module should be connected to the second pin of the TB3 connector. Refer to the unit's wiring diagram for more information.

### **A. STEP 2 – CONFIGURING THE HUMIDIFIERS**

#### **NOTE**

If the LINKS 2 remote package was shipped with the humidifiers, this step will have already been performed by the factory.

- (1) Since Nortec LINKS 2 can connect to a maximum of 8 units, it will be necessary to set the unit address for each humidifier. The lead unit can be determined by the presence of the LINKS 2 module. The slave humidifiers can be given a unit address according to the number the unit will have on the networked chain.
- (2) To set the network address access the User Parameter level in the humidifier software menu. Scroll down to Modbus Settings and press enter.
- (3) In order to change the current modbus address, press the up and down arrows on the keypad at the same time. When prompted, enter the code 0335.
- (4) Once the password is set select the modbus address heading and press enter. Use the up and down arrows to change the address setting.
- (5) Determine the desired humidifier ordering on the network. To change the network instance follow step 3 and enter the parameter value of 2 for unit 2, 3 for unit 3 and soon.

**10-10**  
**LINKS 2 -**  
**FIELD CONVERSION OF**  
**A GSTC/SETC**

## (1) FIELD CONVERSION OF A GSTC/SETC SERIES HUMIDIFIER WITH NORTEC LINKS 2

### BACNET, LONWORKS AND N2 MODULES:

#### A. WIRING THE NORTEC LINKS 2 MODULE

- (1) Most of the wiring connections for the new Nortec LINKS 2 module will have already been finished at the factory, however, there are a few connections that will need to be made to connect the unit the GS/SE series humidifier. Refer the LINKS 2 wiring diagram included in the package for details.
- (2) Module Power Connections:
  - (a) There will be a wire harness provided that will consist of a red and blue wire, each terminated with a ring terminal. These wires should already be connected to the 24VAC and GND terminals on the LINKS 2 terminal strip. The ring terminal of the red wire is to be connected to the 24V side of the 120/24 VAC transformer located at the bottom, left of the electrical compartment. The connection point will be labelled XF at the transformer.
  - (b) The ring terminal of the blue wire will need to be connected to the ground terminal on the 120/24 VAC transformer.
- (3) Humidifier Communication Connection:
  - (a) On the Nortec LINKS 2 assembly there will be a black 2-pole connector present that is connected to a white and black wire. This connector is to be plugged into the TB3 jack on the right side of the humidifier mainboard.

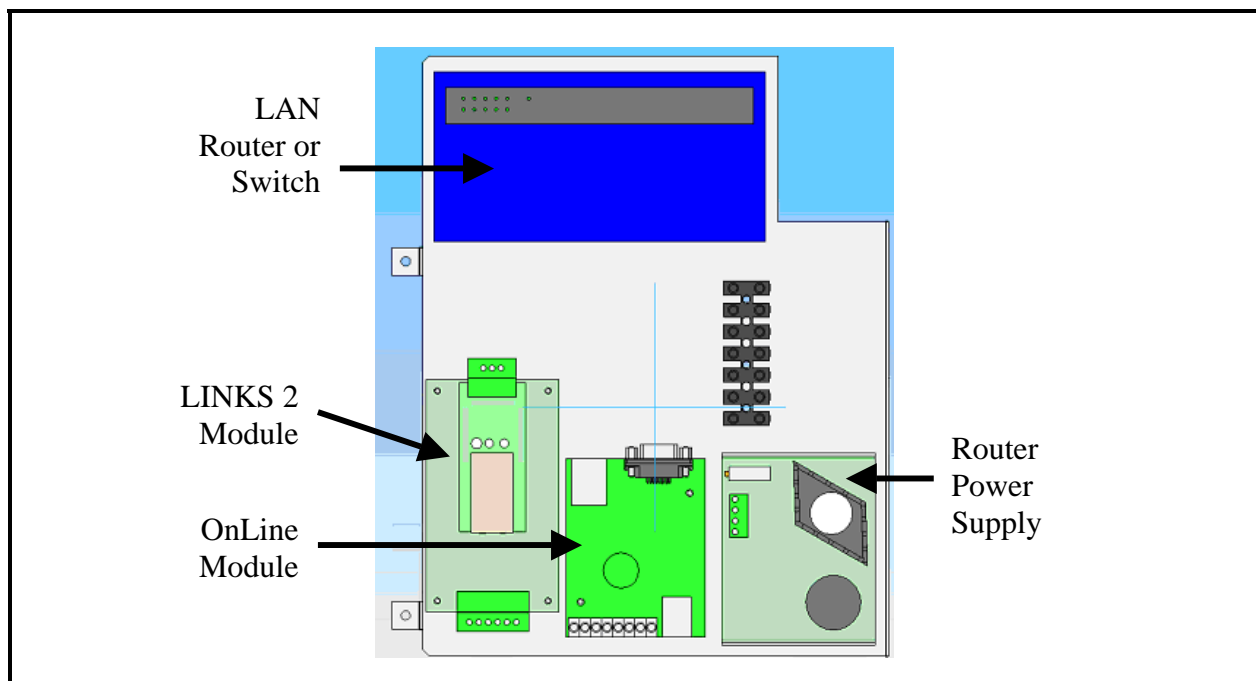

Figure 1. Component Identification

## B. MOUNTING THE LINKS 2 ASSEMBLY

- (1) Refer to Figure 2 for the mounting location of the Nortec LINKS 2 Bracket on the GS or SE unit. If pilot holes for the mounting screws are not already present on the humidifier frame follow steps 2 and 3. If pilot holes are present then disregard steps 2 and 3.
- (2) Using the bracket assembly as a template, mark locations of pilot holes on the GS/SE humidifier frame.
- (3) Using 1/8" drill bit, drill pilot holes for the bracket mounting screws.
- (4) Install the bracket assembly using 8-32x 1/2" hex-drive screws. Be sure to route the power wires for the I/O Controller-E module through the cutout on the upper right-hand corner of the bracket, as illustrated in the following figure. After running wires behind bracket, route the power leads into the main wire track.

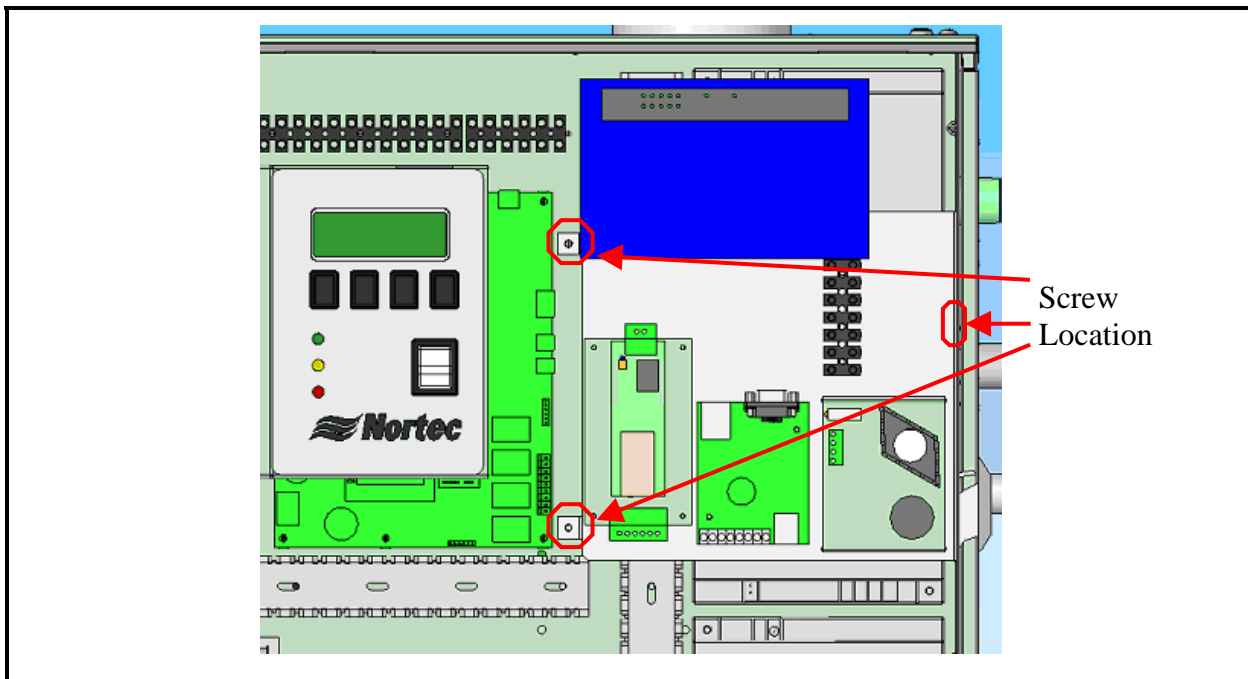

Figure 2. LINKS 2 Bracket Placement



### **C. CONFIGURING THE HUMIDIFIERS**

- (1) Since Nortec LINKS 2 can connect to a maximum of 8 units, it will be necessary to set the unit address for each humidifier. The lead unit can be determined by the presence of the Links module. The slave humidifiers can be given a unit address according to the number the unit will have on the networked chain.
- (2) To set the network address access the User Parameter level in the humidifier software menu. Scroll down to Modbus Settings and press enter.
- (3) In order to change the current Modbus address, press the up and down arrows on the keypad at the same time. When prompted, enter the code 0335.
- (4) Once the password is set select the Modbus address heading and press enter. Use the up and down arrows to change the address setting.
- (5) Determine the desired humidifier ordering on the network. To change the network instance follow step 3 and enter the parameter value of 2 for unit 2, 3 for unit 3 and so on.
- (6) Place the appropriate Unit Identifier label on each humidifier. These labels should be placed on the unit where the electrical control punch-outs are located at the top of the humidifier.
- (7) Connect the slave humidifiers (if applicable) to the Nortec Links Module. A twisted pair cable should be used so that the Net + terminal on the Links module should connect to the first pin (bottom-most pin) of the TB3 connector. The Net – terminal on the module should be connected to the second pin of the TB3 connector. Refer to the unit's wiring diagram for more information.

**10-20**  
**LINKS 2 -**  
**FIELD CONVERSION OF**  
**A NHTC**

## (1) FIELD CONVERSION OF A NHTC SERIES HUMIDIFIER WITH NORTEC LINKS 2

BACNET, LONWORKS AND N2 MODULES:

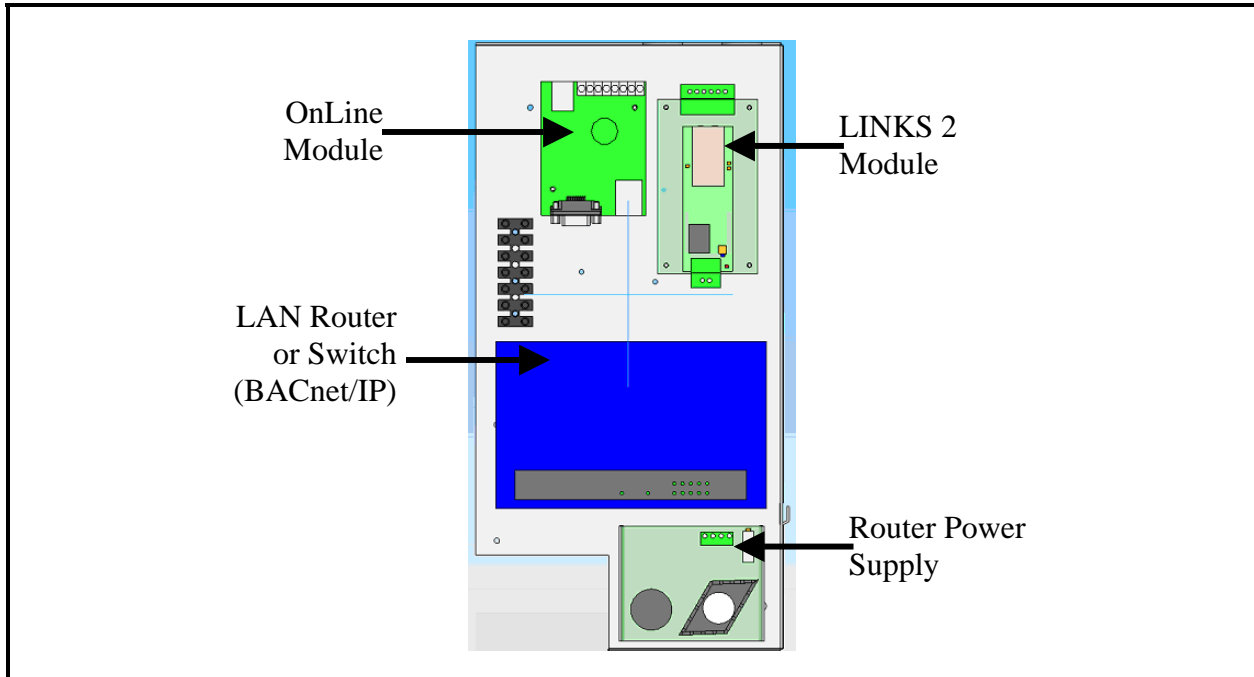

Figure 1. Component Identification

### A. MOUNT THE LINKS 2 ASSEMBLY

- (1) The Nortec LINKS 2 assembly mounts on the top, right corner of the electrical compartment.
- (2) Ensure that the rear, upwards facing hook engages the proper cooling louver at the back of the humidifier cabinet.
  - (a) Fasten the bracket assembly to the humidifier 'top' using the 3 8-32 X ½" self-tapping screws provided with the kit.

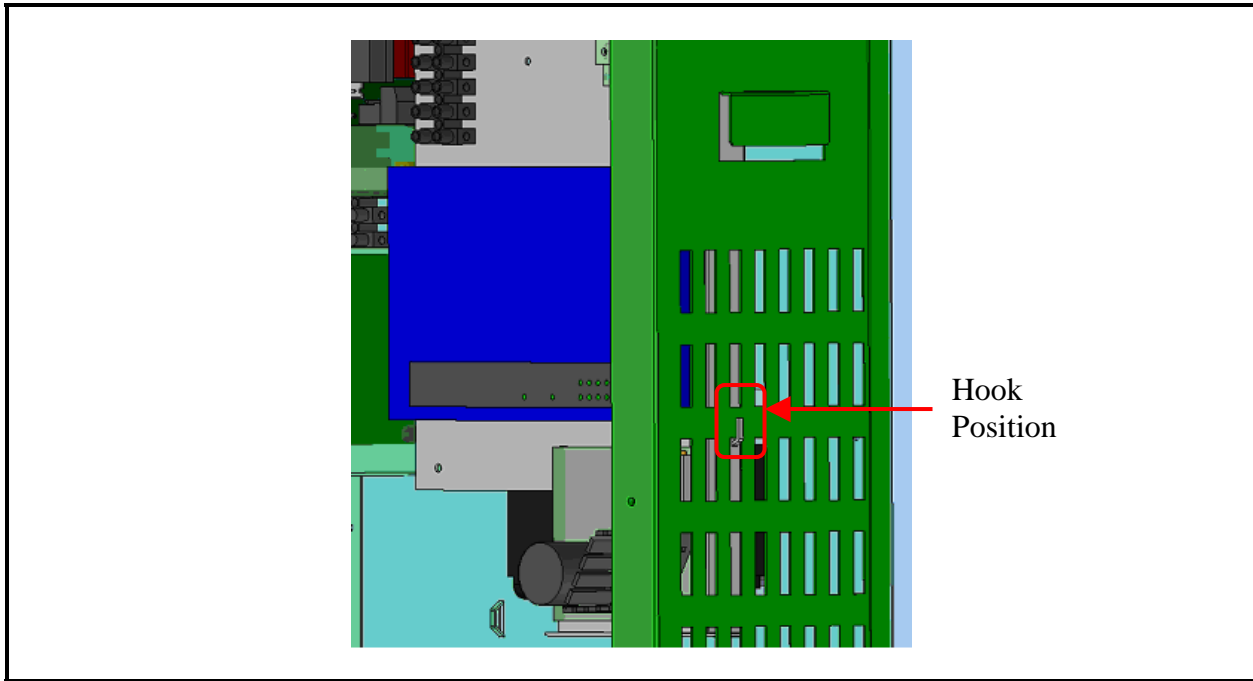

Figure 2. Hook Position

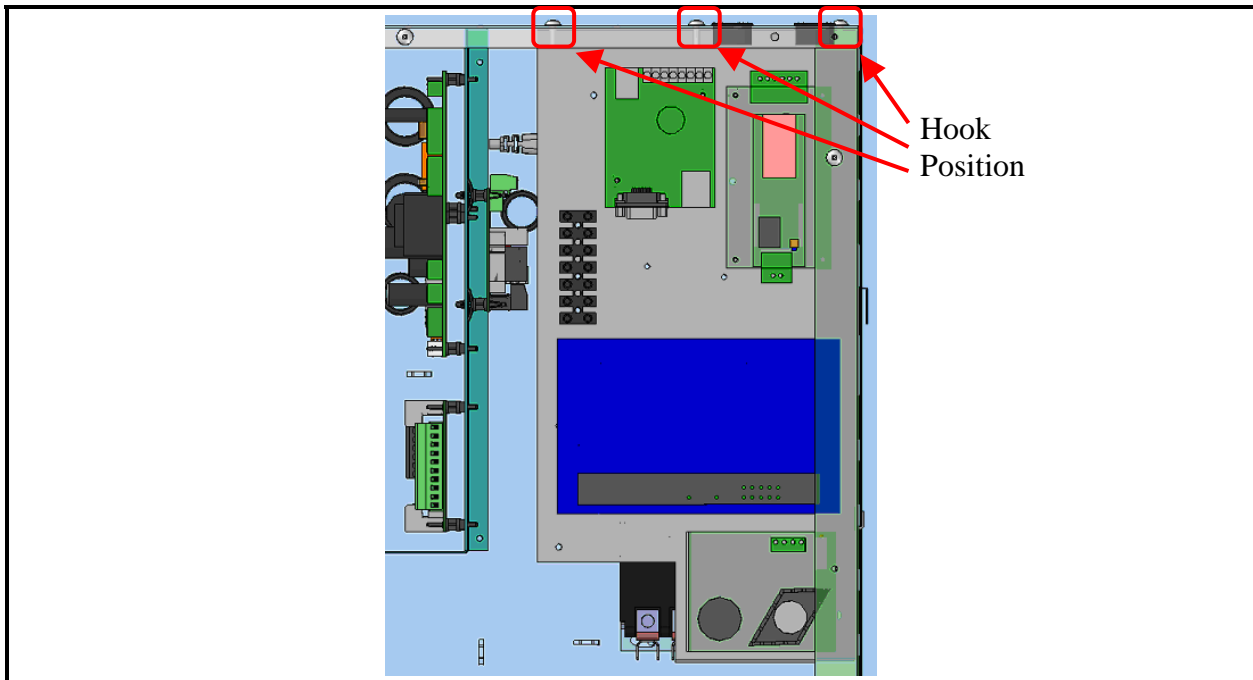

Figure 3. Assembly Mounting Location

## **B. CONFIGURING THE HUMIDIFIERS**

- (1) Since Nortec LINKS 2 can connect to a maximum of 8 units, it will be necessary to set the unit address for each humidifier. The lead unit can be determined by the presence of the Links module. The slave humidifiers can be given a unit address according to the number the unit will have on the networked chain.
- (2) Press the menu button and enter the password 0459.
- (3) Scroll down and select Factory Settings.
- (4) Scroll and select Core Parameters.
- (5) Select Modbus Parameters.
- (6) Set the communication parity to Even.
- (7) Set the appropriate Modbus address according to the unit ordering.
- (8) Connect the slave humidifiers (if applicable) to the Nortec Links Module. A twisted pair cable should be used so that the Net + terminal on the Links module should connect to the Net + terminal on the slave unit (NHTC). The Net – terminal on the module should be connected to the Net – terminal on the slave unit. Refer to the unit's wiring diagram for more information.

**10-30**  
**LINKS 2 -**  
**FIELD CONVERSION OF**  
**A NHDI/SC**

## (1) FIELD CONVERSION OF A NNDI/SC SERIES HUMIDIFIER WITH NORTEC LINKS 2

### BACNET, LONWORKS AND N2 MODULES:

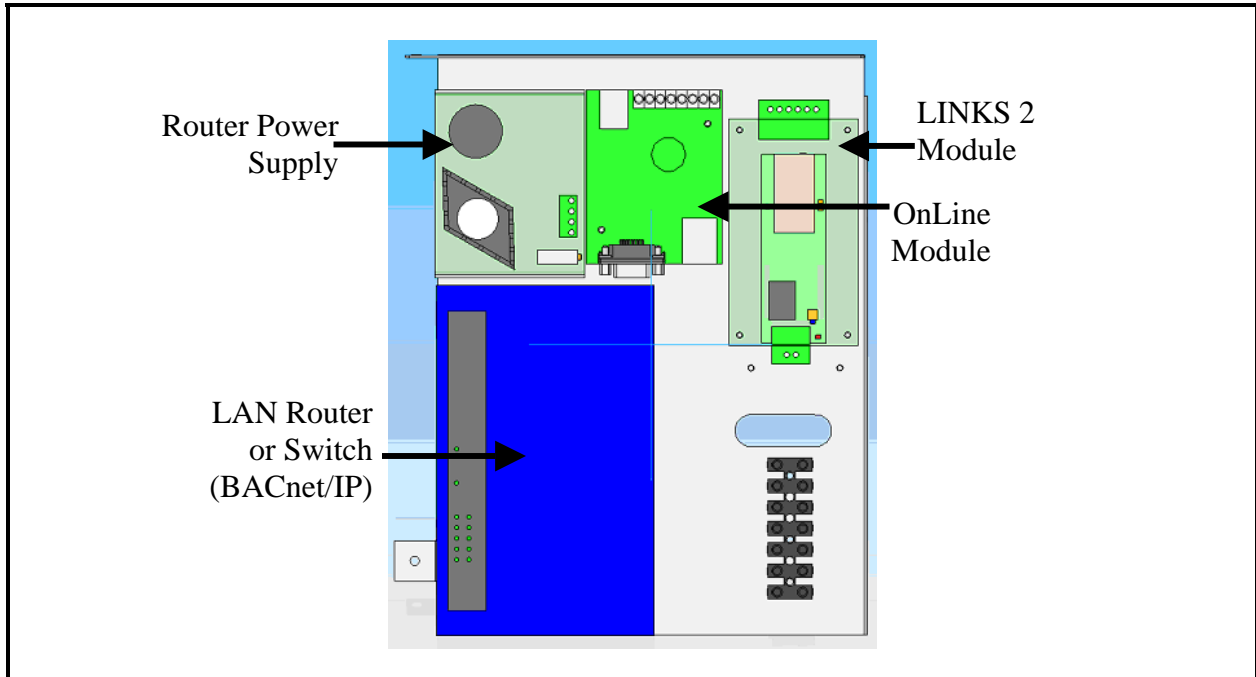
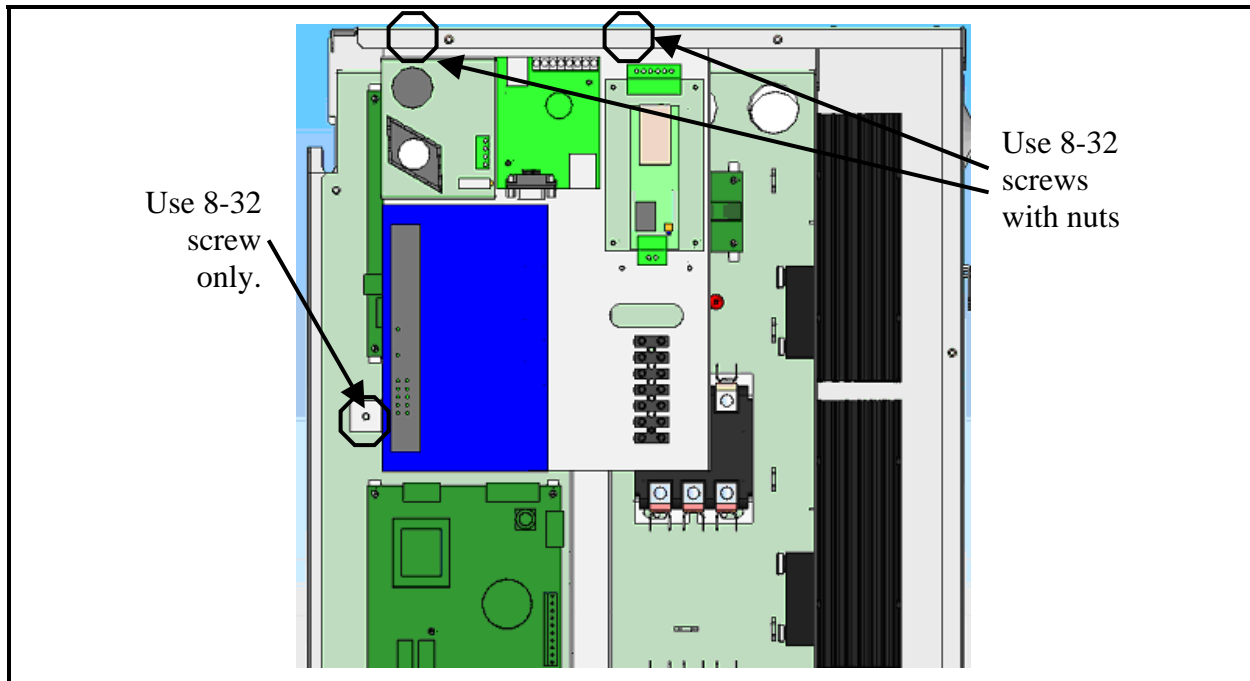

Figure 1. Component Identification

#### A. MOUNT THE LINKS 2 ASSEMBLY

- (1) Refer to Figure 2 for the mounting location of the Nortec LINKS 2 Bracket on the NNDI or NHSC unit. If pilot holes for the mounting screws are not already present on the humidifier frame follow steps 2 and 3. If pilot holes are present then disregard steps 2 and 3.
- (2) Using the bracket assembly as a template, mark locations of pilot holes on the NNDI/SC humidifier cabinetry.
- (3) Using 1/8" drill bit, drill pilot holes for the bracket mounting screws.
- (4) Install the bracket assembly using the provided #8-32 screws. Note that 2 #8-32 nuts have been supplied to secure the 2 top mounts. The third screw will thread into the humidifier cabinet itself.



**Figure 2. LINKS 2 Bracket Placement**

## **B. WIRING THE NORTEC LINKS 2 MODULE**

- (1) Most of the wiring connections for the Nortec LINKS 2 module will have already been finished at the factory, however, there are a few connections that will need to be made to connect the module to the NHD/SC series humidifier. Refer the LINKS 2 wiring diagram included in the package for details.
- (2) Module Wire Connections:
  - (a) There will be a wire harness provided that will consist of a red and blue wire, each terminated with a bare end. These wires should already be connected to the 24VAC and GND terminals on the LINKS 2 terminal strip. Both wires will be connected to the 5-pole connector labelled **X1 (Main Supply)** located on the humidifier support board. The red wire is to be connected to the terminal labelled **L1**. The blue wire is to be connected to the terminal labelled **N**.
  - (b) A loose ribbon cable with a 10-pin header plug and a 20-pin header plug will be included with the kit. The 20-pin header plug should be connected to the J2 connector on the TTL-to-RS485 converter located on the back of the LINKS 2 mounting bracket. The 10-pin header plug should be connected to the COM PORT connector located on the NHD/SC Logic Board.





**Figure 3. NHD1 LINKS 2 Slave Installation**

- (3) Installation of LINKS 2 Slave Option
  - (a) The LINKS 2 module is capable of supporting up to 8 humidifiers when each unit is equipped with a TTL to RS-485 signal converter. The LINKS 2 slave option consists of a small bracket with the signal converter mounted on one side. In addition a terminal strip is provided to allow the humidifiers to be wired back to the master module.
  - (b) Mount the LINKS slave option on any humidifier that will be connected to the master module. The slave option mounts in the same location as the master LINKS module. Use 2 #8-32 screws and 2 #8-32 nuts to secure the bracket to the top of the humidifier cabinet.
  - (c) The provided 3-position terminal strip will be installed next to the standard humidifier strip using 2 #6-32 screws. For units being retrofitted, the existing terminal strip may have to be shifted to the right for the LINKS terminal strip to fit.
  - (d) Connect the 4-pin modular plug into one of the 2 modular jacks on the TTL to RS-485 signal converter.

(4) Configuring the Humidifiers

- (a) Since Nortec LINKS 2 can connect to a maximum of 8 units, it will be necessary to set the unit address for each humidifier. The lead unit can be determined by the presence of the LINKS module and should be set to modbus address 1. The slave humidifiers can be given a unit address according to the number the unit will have on the networked chain.
- (b) In order to change the current modbus address, press the up and down arrows on the keypad at the same time. When prompted, enter the code 8808. Note: Each column of the password may be adjusted with the up or down arrow keys. Once that number is set, pressing the enter key will move the cursor to the next column.
- (c) Once the password is set, select the modbus address heading and press enter. Use the up and down arrows to change the address setting.
- (d) Determine the desired humidifier ordering on the network. To change the network instance follow step 3 and enter the parameter value of 2 for unit 2, 3 for unit 3 and so on.
- (e) Place the appropriate Unit Identifier label on each humidifier. These labels should be placed below the user terminal strip located in the electrical cabinet section of the humidifier.
- (f) Connect the slave humidifiers (if applicable) to the Nortec LINKS 2 Module. A twisted pair cable should be used so that the Net + terminal on the LINKS module connects to the Net+ terminal of the NHDI/SC slave option. The Net – terminal on the LINKS 2 module should also be connected to the Net-terminal of the slave option. Refer to the unit's wiring diagram for more information.

## **WARRANTY**

- (1) WALTER MEIER INC. and/or WALTER MEIER LTD. (hereinafter collectively referred to as THE COMPANY), warrant for a period of two years after installation or 30 months from manufacturer's ship date, whichever date is earlier, that THE COMPANY's manufactured and assembled products, not otherwise expressly warranted (with the exception of the cylinder), are free from defects in material and workmanship. No warranty is made against corrosion, deterioration, or suitability of substituted materials used as a result of compliance with government regulations.
- (2) THE COMPANY's obligations and liabilities under this warranty are limited to furnishing replacement parts to the customer, F.O.B. THE COMPANY's factory, providing the defective part(s) is returned freight prepaid by the customer. Parts used for repairs are warranted for the balance of the term of the warranty on the original humidifier or 90 days, whichever is longer.
- (3) The warranties set forth herein are in lieu of all other warranties expressed or implied by law. No liability whatsoever shall be attached to THE COMPANY until said products have been paid for in full and then said liability shall be limited to the original purchase price for the product. Any further warranty must be in writing, signed by an officer of THE COMPANY.
- (4) THE COMPANY's limited warranty on accessories, not of the companies manufacture, such as controls, humidistats, pumps, etc. is limited to the warranty of the original equipment manufacturer from date of original shipment of humidifier.
- (5) THE COMPANY makes no warranty and assumes no liability unless the equipment is installed in strict accordance with a copy of the catalog and installation manual in effect at the date of purchase and by a contractor approved by THE COMPANY to install such equipment.
- (6) THE COMPANY makes no warranty and assumes no liability whatsoever for consequential damage or damage resulting directly from misapplication, incorrect sizing or lack of proper maintenance of the equipment.
- (7) THE COMPANY retains the right to change the design, specification and performance criteria of its products without notice or obligation.

INSTALLATION DATE (MM/DD/YYYY)

MODEL #

SERIAL #

CYLINDER #

**walter  
meier**

**U.S.A.**  
**Walter Meier (Climate USA) Inc.**  
826 Proctor Avenue  
Ogdensburg, NY 13669  
TEL: 1-866-NORTEC-1  
EMAIL: nortec@humidity.com  
WEBSITE: www.humidity.com

**CANADA**  
**Walter Meier (Climate Canada) Ltd.**  
2740 Fenton Road  
Ottawa, ON K1T 3T7  
TEL: 1-866-NORTEC-1  
FAX: (613) 822-7964



Certificate No. 002419

Authorized Agent: