

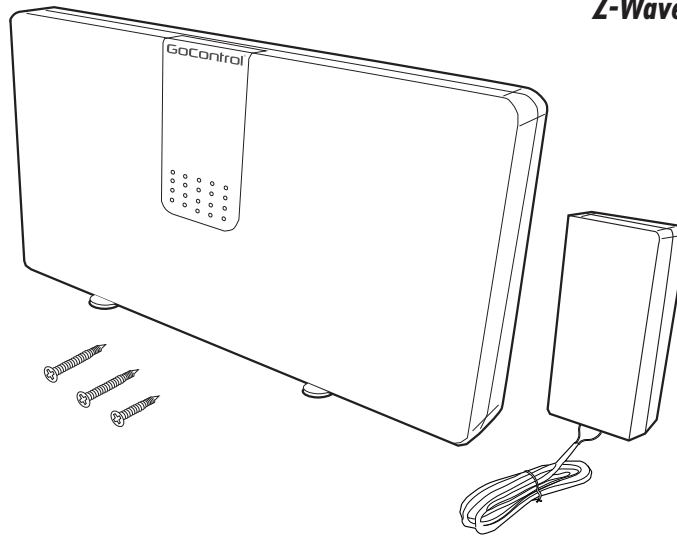

WI15Z-1 IRRIGATION CONTROLLER

Z-Wave Radio Frequency (RF) Controlled



WI15Z-1 IRRIGATION CONTROLLER

The GoControl™ family of Z-Wave® certified wireless lighting products (smart LED fixtures, bulbs, switches, dimmers, outlets, and plug-in modules) Control Products (thermostats, irrigation controller and garage door controller) and Sensors (flood, leak, alert sounder, motion sensor and door/window sensor) bring a new level of intelligent wireless Home Automation capability to commercial and residential environments.

The Z-Wave wireless protocol is an international wireless standard for remote home automation, security and other applications. This product can be included and operated in any Z-Wave network with other Z-Wave certified devices from other manufacturers and/or other applications. All non-battery operated nodes within the network will act as repeaters regardless of vendor to increase reliability of the network.

The WI15Z-1 allows you to take charge of your sprinkler and landscape watering usage, saving money and this precious resource. Using real-time micro-climate information from your Z-Wave hub, up to 15 connected valves are tailored to your specific irrigation environment.

GoControl Z-Wave products are easy to install, are Z-Wave certified, and allow dealers to create an integrated wireless network with nearly limitless expansion and interoperability with security, energy management, home entertainment, appliances, and more.

Z-WAVE PLUS FEATURES

The GoControl Irrigation Controller contains a Z-Wave 500 Series Module that supports Z-Wave Plus® features. A Z-Wave certified portable or stationary Controller can communicate with the Z-Wave 500 Series Module.

Depending on the capability of the Z-Wave Controller or gateway software, the following operations can be performed with the GoControl Irrigation Controller. Refer to the Z-Wave Controller or gateway manual for details.

- Turn the 24 VAC residential irrigation valve ON and OFF.
- Add or Remove the GoControl Irrigation Controller.
- Over-the-air firmware update by the gateway or static Controller.
- Lifeline function which automatically notifies the associated modules and the network that a manually reset device is no longer in the network, thus, the corresponding association becomes invalid.

Location of Controller

When installing the WI15Z-1 Controller keep the following points in mind:

- Choose a location near an electrical outlet.
- Place unit away from direct sunlight.
- Locate WI15Z-1 Controller so that there is easy access to the sprinkler valve wires.

Installing Controller

1. Mount the WI15Z-1 Controller in the desired location. Install one screw into the wall and hang Controller by the locking slot center hole.
2. Remove Front Cover of Controller and install the two additional screws to lock unit in place on the wall.

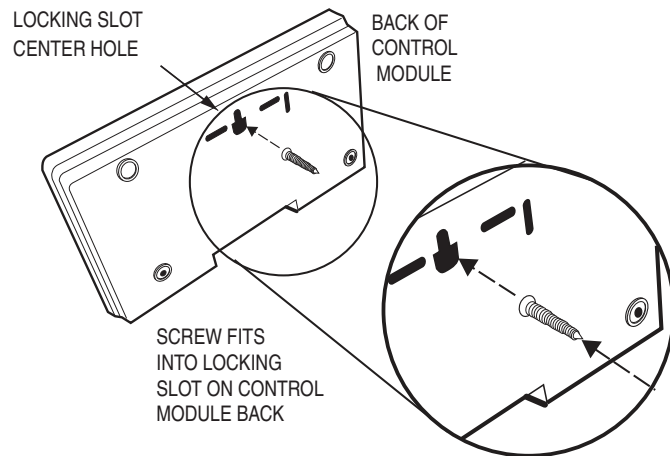

Figure 1. Screw in Locking Slot

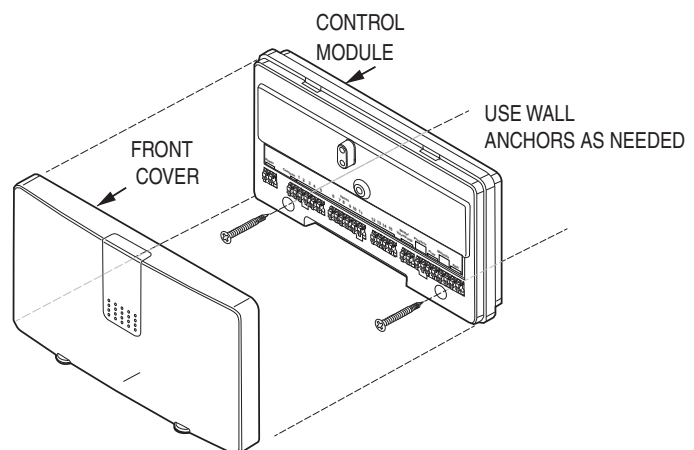

Figure 2. Control Module Locking Screws

Wiring to the Controller

The WI15VZ-1 Controller has 28 terminal connections. The recommended wire used to connect to terminals is in the range of 16 to 22 gauge single strand. To connect a wire to the terminal, use a small screwdriver or pen. While pushing in on the terminal block, insert the wire end into receptor hole (See Figure 3).

Terminal Connection Identification

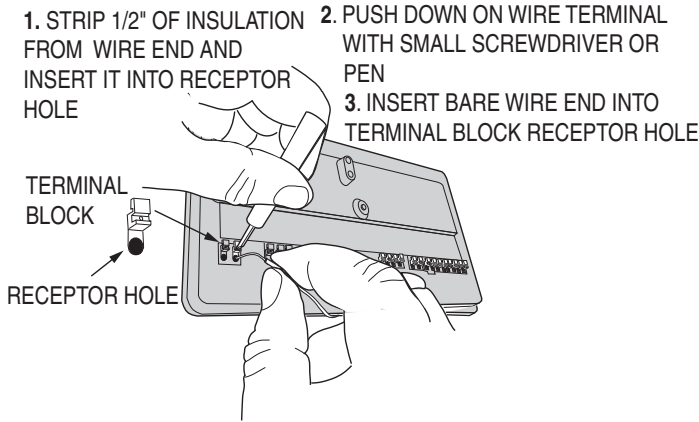

Figure 3. Wiring to Terminal Connection

Wiring Valves to Controller

The WI15VZ-1 Controller accommodates up to 15 valves.

1. Begin the wiring sequence by stripping a wire end and inserting it into the "Common" terminal on the Controller.
2. Connect the Common wire to (1) one of the valves. (For simplicity only two valves are shown in diagram below. A maximum of 15 valves can be wired to the controller. Connect the other wire of each valve to a corresponding wire of the cable bundle. All connections should be made with wire nuts. To prevent electrical overload one common wire should be connected to each valve and only one valve should be connected to each station (See Figure 4).

IMPORTANT: The connection wires can be buried in the ground, however, for more protection, wires can be fed through PVC pipe then buried. Be sure to avoid placing wires in the vicinity where future trenching or digging may occur as this can damage the connections.

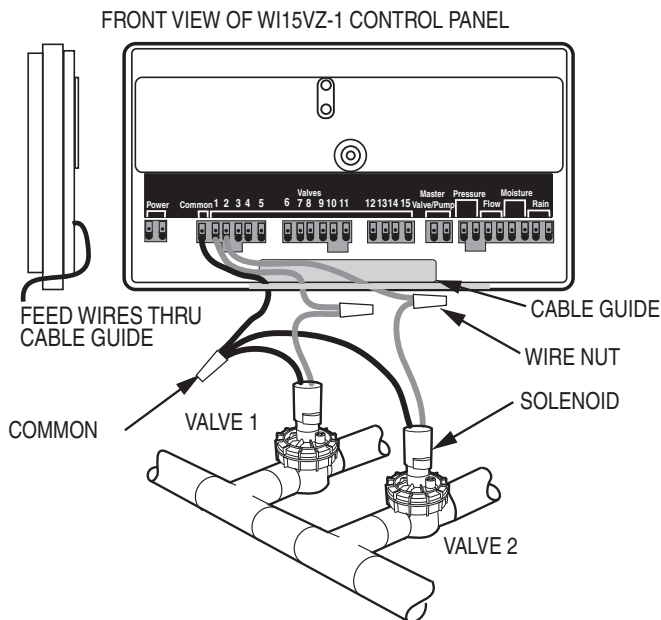

Figure 4. Wiring Valves to Controller

Valve Identification

During the valve wiring process, it will be necessary to label the valve name and location. There is a Valve Identification Label located on the inside of the WI15VZ-1 front cover (examples: front lawn, roses, grass, southside, drip). Here is where valve information can be written (See Figure 5).

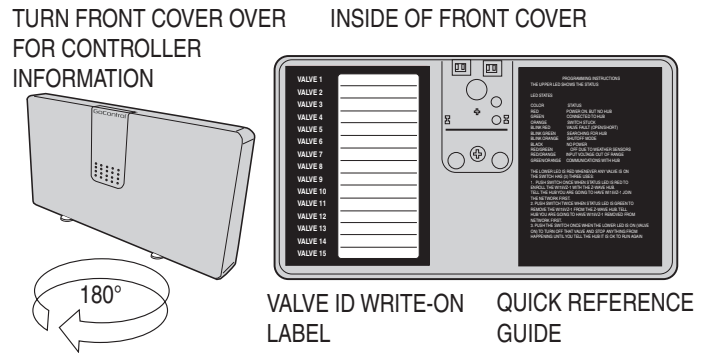

Figure 5. Wiring to Terminal Connection

Wiring of Optional Third Party Components to Controller

The WI15VZ-1 Controller has provisions for a number of additional components. Each component has two terminal connections. See the figure below for more details. Be sure to run the wires from the terminals, thru the cable guide on the lower edge of the controller (See Figure 6 and 6A).

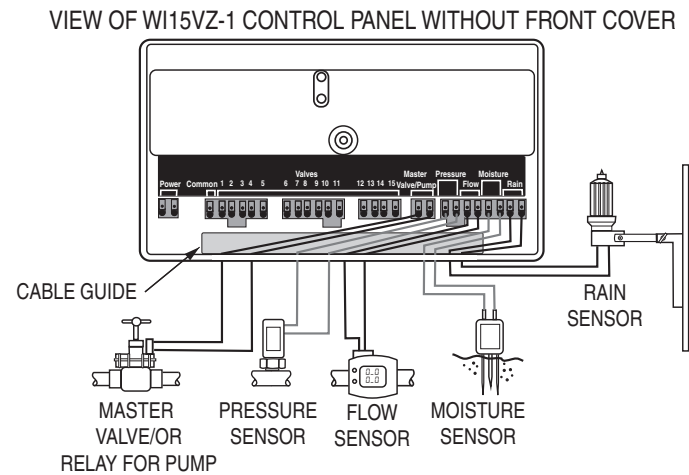

Figure 6. Third Party Component to Controller Wiring

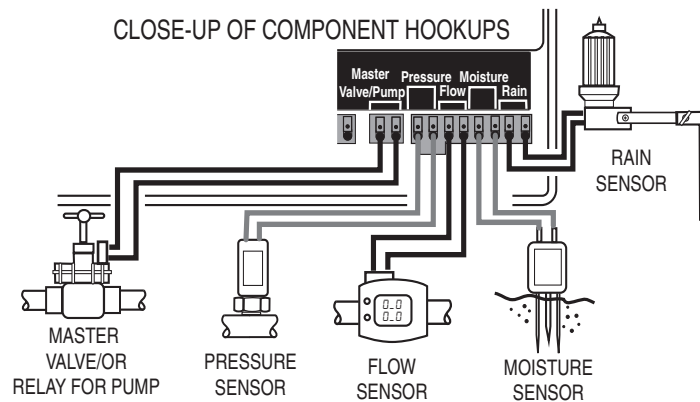

Figure 6A. Closeup of Third Party Components to Controller Wiring

Power Connection

Connect the power adaptor (included) to the power terminals (See Figure 7).

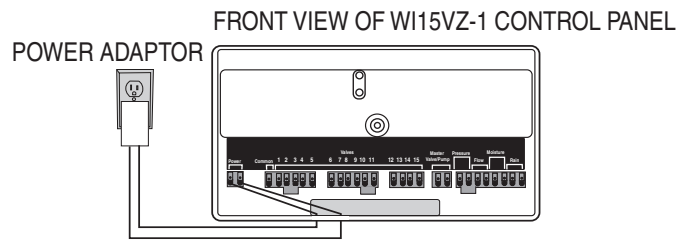

Figure 7. Connecting Power Adaptor

Refer to your controller operating instructions to add this device under the command of the controller.

1. With your controller in Discovery or Add Mode, tap the push button.
2. You should see an indication on your controller that the "device was added" to the network and the Green LED will blink 3 times.
3. The device will appear in the list of Switches. It should display as a switch. If the controller shows the addition failed, repeat Steps 1-3.

Adding to a Network

✓ **NOTE:** If you have trouble adding the GoControl Irrigation Controller to a group it may be that the Home ID and Node ID were not cleared from it after testing. You must first "RESET UNIT" to remove it from the network. Although adding it to a group includes it in the network, removing it from a group does not remove it from the network. If removed from a group, it functions as a repeater (only). "RESET UNIT" removes it completely from the network.

To Reset Unit (If Required):

In the event that your primary controller is lost or otherwise inoperable, to reset the GoControl Irrigation Controller and clear all network information, follow these steps:

1. Tap the push button five (5) times.
2. Then press and hold the push button for 15 seconds. The LED will increasingly blink faster to indicate that a Reset is taking place.

Removing from a Network:

The GoControl Irrigation Controller can be removed from the network by the controller. Refer to the controller operating instructions for details.

1. Set the controller into Removal Mode and follow its instruction to delete it from the controller.
2. Remove the switch by tapping the push button 2 times.
3. You should see an indication on your controller that the "device was removed" from the network and the Green LED will blink 3 times.

LED Status

1. Pushing the button on the WI15VZ-1, will get the Irrigation Controller to associate with the Z-Wave hub (Figure 8).
2. The LED should be red when first powered
- ✓ **NOTE:** Before the LED shows solid RED, it may go through a flashing sequence for self test..
3. When the button is pushed it will blink green then alternate between green and orange, then go solid green.

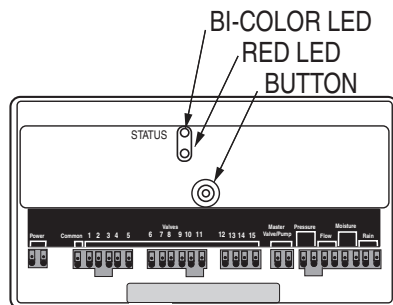

Figure 8. LED Status/Button Location

OPERATION

The WI15Z-1 is designed to run the irrigation system based on your pre-programmed schedule. Utilizing your Z-Wave hub, you can create this schedule. It will be saved in the WI15Z-1 and run automatically unless an Interrupt is sent received.

In the event that your hub does not support schedules, or no schedule is programmed into the Irrigation Controller, each valve can run independently and be triggered as part of a scene. See your hub instructions on how to configure the system to operate in this manner.

To trigger a specific valve that is connected to the WI15Z-1, use the control application associated to you Z-Wave hub.

Weather / Optional Water Sensor Interrupt

The WI15Z-1 can take instructions from your Hub to not run the pre-determined irrigation schedule. In the event that your local weather causes the WI15Z-1 to not run the re-determined irrigation schedule, the LED will blink red / green for as long as the valves are supposed to be running. Once the valves are turned off, it will stop blinking.

All Stop

In the event that you wish to stop the scheduled running of the irrigation controller, press the User Button on the front of the WI15Z-1.

The LED will blink Orange for 15 seconds. After 15 seconds it will continue to blink Orange until the user presses the Button again, or the Hub tells it to go back to normal mode.

Valve Fault Detection

The WI15Z-1 can detect if a valve is disconnected or has damaged or shorted control wires. In the event that a Fault is detected, the LED will blink Red as long as the valve is running. Once the valve is turned off, it will stop blinking Red.

Power Fault Detection

The WI15Z-1 can determine if there is a problem with the power provided by the power supply. In the event that a Fault is detected, the LED will blink Red/Orange until the problem is corrected.

Bi-Color LED States	
Color	Status
Red-On	No Hub
Green-On	Connected to Hub
Orange-On	Stuck Button
Red - Blinking	Valve Fault (open/short)
Green - Blinking	Searching for Hub
Orange - Blinking	Flow Fault (too low/too high)
Red/Green - Toggle	Off due to sensors or weather.
Red/Orange - Toggle	Power out of range.
Green/Orange - Toggle	Communicating with Hub
None	No Power

Status Table for LED States

Z-WAVE COMMAND CLASSES

COMMAND_CLASS_ZWAVEPLUS_INFO
COMMAND_CLASS_BINARY_SWITCH
COMMAND_CLASS_ASSOCIATION
COMMAND_CLASS_ASSOCIATION_GRP_INFO
COMMAND_CLASS_BASIC
COMMAND_CLASS_VERSION
COMMAND_CLASS_MANUFACTURING_SPECIFIC
COMMAND_CLASS_DEVICE_RESET_LOCALLY
COMMAND_CLASS_POWERLEVEL
COMMAND_CLASS_CONFIGURATION_V1
COMMAND_CLASS_IRRIGATION
COMMAND_CLASS_FIRMWARE_UPDATE_MD
COMMAND_CLASS_NOTIFICATION
COMMAND_CLASS_SCHEDULE

SPECIFICATIONS

Power:	120 VAC,, 60 Hz Input, 18VDC 1A Output
Signal (Frequency):	908.42 MHz/916 MHz
Range:	Up to 130 feet line of sight
Valves Supported:	Up to 15. Residential 24 VAC
Operating Temperature:	32 - 158°F (0 - 70° C

NOTICES

Z-Wave® and Z-Wave Plus® are registered trademarks of Sigma Designs and its subsidiaries in the United States and other countries.

WARRANTY

What is Covered?

Nortek Security & Control ("NS&C") warrants to consumers who purchase this product for personal, family or household purposes new from NS&C directly or from an authorized NS&C dealer, that the product will be free from defects in materials and workmanship for a period of (1) year from the date of purchase. This warranty only applies if the product is installed at a residence in the 50 United States or District of Columbia, and only at the site of the original installation. It is not transferable. This warranty is not extended to resellers. If a defect exists, NS&C will have you ship the defective part or product to us and we will, at our option, either repair or replace it. This warranty does **not** cover the cost of labor to remove a defective part or product or to reinstall any repaired or replacement part.

This warranty does **not** cover defects or damages caused by improper handling, maintenance, storage, installation, removal or re-installation, misuse, non-factory authorized modification or alteration, use of incompatible accessories, electrical power problems or surges, impact by foreign objects, accident, fire, acts of God, normal wear and tear or shipping damage other than a shipment from NS&C. Note that all NS&C products are designed to be installed, removed and serviced by trained individuals or professionals.

Keep your original sales receipt as it will be required to obtain warranty service.

This warranty shall not be extended or restarted upon receipt of any repaired or replacement part or product under this warranty. No person is authorized to extend or otherwise modify this warranty.

How do I Obtain Warranty Service?

To obtain warranty service, email our Returns Department at returns@nortek.com. Include your name, address, telephone number, the model number of your product, a copy of your original sales receipt, and a description of the problem. Unless we need to discuss the situation further with you, you will be emailed a Return Authorization Number and shipping instructions. If we need to discuss the situation further with you, we will call or email you. NS&C may require troubleshooting on installed product before a Return Authorization Number is issued. Anything shipped to us without a Return Authorization Number will be automatically returned unopened. You are responsible for the charges for shipment to us, unless you are a California resident.

Limitations

THE DURATION OF ANY IMPLIED WARRANTY, INCLUDING THE WARRANTIES OF MERCHANTABILITY AND FITNESS FOR A PARTICULAR PURPOSE, SHALL NOT EXCEED THE WARRANTY PERIOD PROVIDED HEREIN.

Some states do not allow limitations on how long an implied warranty lasts, so the above limitation may not apply to you.

NS&C SHALL NOT BE LIABLE FOR ANY INCIDENTAL OR CONSEQUENTIAL DAMAGES RESULTING FROM THE BREACH OF ANY WRITTEN OR IMPLIED WARRANTY.

Some states do not allow the exclusion of limitation or consequential damages, so the above limitation or exclusion may not apply to you. which vary from state to state.

Copyright © 2015 Nortek Security & Control LLC

This warranty gives you specific legal rights, and you may also have other legal rights which vary from State to State.

FCC & IC Notice

This device complies with Part 15 of the FCC Rules and Industry Canada license exempt standard(s). Operation is subject to the following two conditions:

- (1) This device may not cause harmful interference, and
- (2) This device must accept any interference received, including interference received that may cause undesired operation.

Le présent appareil est conforme aux CNR d'Industrie Canada applicables aux appareils radio exempts de licence. L'exploitation est autorisée aux deux conditions suivantes:

- (1) l'appareil ne doit pas produire de brouillage, et
- (2) l'utilisateur de l'appareil doit accepter tout brouillage radioélectrique subi, même si le brouillage est susceptible d'en compromettre le fonctionnement.

This Class B digital apparatus complies with Canadian ICES-003

Cet appareil numérique de la classe B est conforme à la norme NMB-003 du Canada.

This equipment has been tested and found to comply with the limits for a Class B digital device, pursuant to Part 15 of the FCC Rules. These limits are designed to provide reasonable protection against harmful interference in a residential installation.

This equipment generates, uses, and can radiate radio frequency energy and, if not installed and used in accordance with the instructions may cause harmful interference to radio communications. However, there is no guarantee that interference will not occur in a particular installation. If this equipment does cause harmful interference to radio or television reception, which can be determined by turning the equipment off and on, the user is encouraged to try to correct the interference by one or more of the following measures:

- Reorient or relocate the receiving antenna.
- Increase the separation between the equipment and receiver
- Connect the equipment into an outlet on a circuit different from that to which the receiver is connected
- Consult the dealer or an experienced radio/TV technician to help.

WARNING:

Changes or modifications not expressly approved by the manufacturer could void the user's authority to operate the equipment.

To satisfy FCC/IC RF exposure safety requirements, a separation distance of 20 cm or more should be maintained between this device and person's body (excluding extremities: hands, wrists, feet and ankles).

IMPORTANT !!!

Radio controls provide a reliable communications link and fill an important need in portable wireless signaling. However, there are some limitations which must be observed.

- For U.S. installations only: The radios are required to comply with FCC Rules and Regulations as Part 15 devices. As such, they have limited transmitter power and therefore limited range.
- A receiver cannot respond to more than one transmitted signal at a time and may be blocked by radio signals that occur on or near their operating frequencies, regardless of code settings.
- Infrequently used radio links should be tested regularly to protect against undetected interference or fault.
- A general knowledge of radio and its vagaries should be gained prior to acting as a wholesale distributor or dealer, and these facts should be communicated to the ultimate users.