



NORTEL

Nortel Communication Server 1000

Communication Server 1000M and Meridian 1 Large System Overview

Release: 5.5

Document Revision: 02.05

www.nortel.com

NN43021-110

Nortel Communication Server 1000
Release: 5.5
Publication: NN43021-110
Document status: Standard
Document release date: 30 September 2008

Copyright © 2003-2008 Nortel Networks
All Rights Reserved.

Sourced in Canada

LEGAL NOTICE

While the information in this document is believed to be accurate and reliable, except as otherwise expressly agreed to in writing NORTEL PROVIDES THIS DOCUMENT "AS IS" WITHOUT WARRANTY OR CONDITION OF ANY KIND, EITHER EXPRESS OR IMPLIED. The information and/or products described in this document are subject to change without notice.

Nortel, Nortel (Logo), the Globemark, SL-1, Meridian 1, and Succession are trademarks of Nortel Networks.

All other trademarks are the property of their respective owners.

Contents

New in this Release	5
Other	5
Revision History	5
How to get help	7
Getting help from the Nortel Web site	7
Getting help over the telephone from a Nortel Solutions Center	7
Getting help from a specialist by using an Express Routing Code	7
Getting help through a Nortel distributor or reseller	8
Introduction	9
Subject	9
Applicable systems	9
Intended audience	10
Conventions	10
Related information	11
Product description	13
Contents	13
Introduction	13
System options	15
CS 1000M HGand Meridian 1 Option 51C	15
CS 1000M SGand Meridian 1 PBX 61C CP PIV	18
CS 1000M MGand Meridian 1 PBX 81C CP PIV	21
System modules	24
NT4N41 Core/Network module	24
NT5D21 Core/Network module	26
NT8D35 Network module	27
Fiber Network Fabric	29
NT8D37 Intelligent Peripheral Equipment module	30
Fiber Remote IPE module	31
Carrier Remote IPE	31
System architecture	33
Contents	33
Hardware architecture	34

Common control complex	35
Network interface	39
Intelligent Peripheral Equipment	43
Terminal equipment	46
Power equipment	47
Signaling Server	49
Software architecture	55
Firmware	56
Software	56
Office data	56
Resident programs	56
Nonresident programs	57
Configuration options	58
Fiber Remote IPE	58
Carrier Remote IPE	61
Branch Office	62
Geographic Redundancy	62

New in this Release

There have been no updates to the document in this release.

Other

Revision History

September 2008	Standard 02.05. This document is up-issued to add content about FIJI redesign in System modules chapter.
September 2008	Standard 02.04. This document is issued to support Communication Server 1000 Release 5.5.
July 2008	Standard 02.03. This document is issued to support Communication Server 1000 Release 5.5.
December 2007	Standard 02.02. This document is issued to support Communication Server 1000 Release 5.5.
June 2007	Standard 1.02. This document is up-issued to remove the Nortel Networks Confidential statement.
May 2007	Standard 1.01. This document is issued to support Communication Server 1000 Release 5.0. This document contains information previously contained in the following legacy document, now retired: <i>Communication Server 1000M and Meridian 1: Large System Overview (553-3021-010)</i> , .
August 2005	Standard 3.00. This document is up-issued to support Communication Server 1000 Release 4.5.
September 2004	Standard 2.00. This document is up-issued for Communication Server 1000 Release 4.0.
October 2003	Standard 1.00. This document is a new NTP for Succession 3.0. It was created to support a restructuring of the Documentation Library. This document contains information previously contained in the following legacy document, now retired: <i>System Overview</i> , (553-3001-100).

How to get help

This chapter explains how to get help for Nortel products and services.

Getting help from the Nortel Web site

The best way to get technical support for Nortel products is from the Nortel Technical Support Web site: www.nortel.com/support

This site provides quick access to software, documentation, bulletins, and tools to address issues with Nortel products. From this site, you can:

- download software, documentation, and product bulletins
- search the Technical Support Web site and the Nortel Knowledge Base for answers to technical issues
- sign up for automatic notification of new software and documentation for Nortel equipment
- open and manage technical support cases

Getting help over the telephone from a Nortel Solutions Center

If you do not find the information you require on the Nortel Technical Support Web site, and you have a Nortel support contract, you can also get help over the telephone from a Nortel Solutions Center.

In North America, call 1-800-4NORTEL (1-800-466-7835).

Outside North America, go to the following Web site to obtain the telephone number for your region: www.nortel.com/callus

Getting help from a specialist by using an Express Routing Code

To access some Nortel Technical Solutions Centers, you can use an Express Routing Code (ERC) to quickly route your call to a specialist in your Nortel product or service. To locate the ERC for your product or service, go to: www.nortel.com/erc

Getting help through a Nortel distributor or reseller

If you purchased a service contract for your Nortel product from a distributor or authorized reseller, contact the technical support staff for that distributor or reseller.

Introduction

This document is a global document. Contact your system supplier or your Nortel representative to verify that the hardware and software described are supported in your area.

Subject



WARNING

Before a Large System can be installed, a network assessment must be performed and the network **must** be VoIP-ready.

If the minimum VoIP network requirements are not met, the system will not operate properly.

For information on the minimum VoIP network requirements and converging a data network with VoIP, refer to *Converging the Data Network with VoIP (NN43001-260)*, .

This document provides an overview of the general design and features of CS 1000Mand Meridian 1 Large Systems.

Note on legacy products and releases

This NTP contains information about systems, components, and features that are compatible with Nortel Communication Server 1000 Release 5.5 software. For more information on legacy products and releases, click the **Technical Documentation** link under **Support & Training** on the Nortel home page:

www.nortel.com

Applicable systems

This document applies to the following systems:

- Communication Server 1000E (CS 1000E) CP PII, CP PIV, and CP PM.
- Communication Server 1000M Single Group (CS 1000M SG) CP PII, CP PIV

- Communication Server 1000M Multi Group (CS 1000M MG) CP PII, CP PIV
- Meridian 1 PBX 11C Chassis
- Meridian 1 PBX 11C Cabinet
- Meridian 1 PBX 61CCP PII, CP PIV
- Meridian 1 PBX 81CCP PII, CP PIV

Note: When upgrading software, memory upgrades may be required on the Signaling Server, the Call Server, or both.

System migration

When particular Meridian 1 systems are upgraded to run CS 1000 Release 5.5 software and configured to include a Signaling Server, they become CS 1000M systems. Table 1 lists each Meridian 1 system that supports an upgrade path to a CS 1000M system.

Table 1
Meridian 1 systems to CS 1000M systems

This Meridian 1 system...	Maps to this CS 1000M system
Meridian 1 PBX 11C Chassis	CS 1000E
Meridian 1 PBX 11C Cabinet	CS 1000E
Meridian 1 PBX 61C	CS 1000MSingle Group
Meridian 1 PBX 81C	CS 1000MMulti Group

For more information, see *Communication Server 1000M and Meridian 1: Large System Upgrade Procedures (NN43021-458)*.

Intended audience

This document is intended to be an introductory overview for individuals responsible for the sale, acquisition, planning, or installation of CS 1000M and Meridian 1 Large Systems.

Conventions

Terminology

In this document, the following systems are referred to generically as "system":

- Communication Server 1000M (CS 1000M)
- Communication Server 1000E (CS 1000E)
- Meridian 1

The following systems are referred to generically as "Large System":

- Communication Server 1000M Single Group (CS 1000M SG)
- Communication Server 1000M Multi Group (CS 1000M MG)
- Meridian 1 PBX 61CCP PII, CP PIV
- Meridian 1 PBX 81CCP PII, CP PIV

Related information

This section lists information sources that relate to this document.

NTPs

The following NTPs are referenced in this document:

- *IP Peer Networking Installation and Commissioning (NN43001-313)*,
- *Converging the Data Network with VoIP Fundamentals (NN43001-260)*,
- *Branch Office Installation and Commissioning (NN43001-314)*,
- *System Redundancy Fundamentals (NN43001-507)*,
- *Telephones and Consoles Fundamentals (NN43001-567)*,
- *IP Phones Fundamentals (NN43001-368)*,
- *Communication Server 1000M and Meridian 1 Large System Planning and Engineering (NN43021-220)*,
- *Fiber Remote IPE Fundamentals (NN43021-554)*,
- *Carrier Remote IPE Fundamentals (NN43021-555)*,
- *Fiber Remote Multi-IPE Interface Fundamentals (N43021-556)*,
- *WLAN Handsets Fundamentals (NN43001-505)*,
- *DECT Fundamentals (NN43120-114)*,
- *Signaling Server Installation and Commissioning (NN43001-312)*,

CD-ROM

To obtain Nortel documentation on CD-ROM, contact your Nortel customer representative.

Product description

Contents

This section contains information on the following topics:

- “Introduction” (page 13)
- “System options” (page 15)
 - “CS 1000M HGand Meridian 1 Option 51C” (page 15)
 - “CS 1000M SGand Meridian 1 PBX 61C CP PIV” (page 18)
 - “CS 1000M MGand Meridian 1 PBX 81C CP PIV” (page 21)
- “System modules” (page 24)
 - “NT4N41 Core/Network module” (page 24)
 - “NT5D21 Core/Network module” (page 26)
 - “NT8D35 Network module” (page 27)
 - “Fiber Network Fabric” (page 29)
 - “NT8D37 Intelligent Peripheral Equipment module” (page 30)
 - “Fiber Remote IPE module” (page 31)
 - “Carrier Remote IPE” (page 31)

Introduction



CAUTION

Before a Large System can be installed, a network assessment must be performed and the network **must** be VoIP-ready.

If the minimum VoIP network requirements are not met, the system will not operate properly.

For information on the minimum VoIP network requirements and converging a data network with VoIP, refer to *Converging the Data Network with VoIP Fundamentals (NN43001-260)*, .

All Large Systems consist of Universal Equipment Modules (UEM) stacked one on top of another to form a column. Each column contains a pedestal, a top cap, and up to four modules. A system can have one column or multiple columns.

Each UEM is a self-contained unit that houses a card cage and backplane, power and ground cabling, power units, input/output (I/O) panels, circuit cards, and cables. When the card cage is installed, the function of the UEM is established and the module is no longer "universal." The system modules are as follows:

- NT4N41 Core/Network module for CS 1000M MG, CS 1000M SG, Meridian 1 PBX 81C CP PIV, and Meridian 1 PBX 61C CP PIV
- NT5D21 Core/Network module for CS 1000M HG, CS 1000M SG, CS 1000M MG, Option 51C, 61C and 81C
- NT8D35 Network module required for CS 1000M MG and Meridian 1 PBX 81C CP PIV, Option 81C
- NT8D37 Intelligent Peripheral Equipment (IPE) module (required for Large Systems)
- Fiber Remote IPE module (optional for Large Systems Multi Group)
- Carrier Remote IPE module (optional for Large Systems)

The pedestal generally houses a blower unit, air filter, Power Distribution Unit (PDU), and System Monitor.

The top cap provides airflow exits, I/O cable entry and exit, and overhead cable-rack mounting. Thermal sensor assemblies for the column are attached to a perforated panel on top of the highest module in the column, under the top cap.

A system can have one column or multiple columns. To comply with FCC and CSA standards for containing electromagnetic interference and radio frequency interference (EMI/RFI), spacer kits connect the columns in a multiple-column system. If a Signaling Server is added to a previously CISPR Class B system (previously used in some specific countries), the system is now Compliant to Class A.

System options

This document includes information on the following Large Systems:

- CS 1000M HGand Meridian 1 Option 51C: enhanced common control complex, single CPU, and one half network group
- CS 1000M SG, Meridian 1 PBX 61C CP PIV, and Meridian 1 Option 61C: enhanced common control complex, dual CPU, and one full-network group
- CS 1000M MG, Meridian 1 PBX 81C CP PIV, Meridian 1 Option 81, and Meridian 1 Option 81C: enhanced common control complex, dual CPU, and multiple-network groups

These systems are available in AC- and DC-powered versions.

CS 1000M HGand Meridian 1 Option 51C

The CS 1000M HGand the Meridian 1 Option 51C are single-CPU systems with a half-network group. One Core/Network module and one IPE module are required. Additional IPE modules, Remote IPE modules, and application modules can be used.

[Table 2 "Specifications for CS 1000M HGand Meridian 1 Option 51C" \(page 17\)](#) lists the specifications for these systems. [Figure 1 "Meridian 1 Option 51C" \(page 16\)](#) illustrates an Option 51C system.

With the addition of a Signaling Server, Meridian 1 Option 51C becomes a CS 1000M HG. [Figure 2 "CS 1000M HG" \(page 16\)](#) on [Figure 2 "CS 1000M HG" \(page 16\)](#) illustrates a CS 1000M HG.

Figure 1
Meridian 1 Option 51C

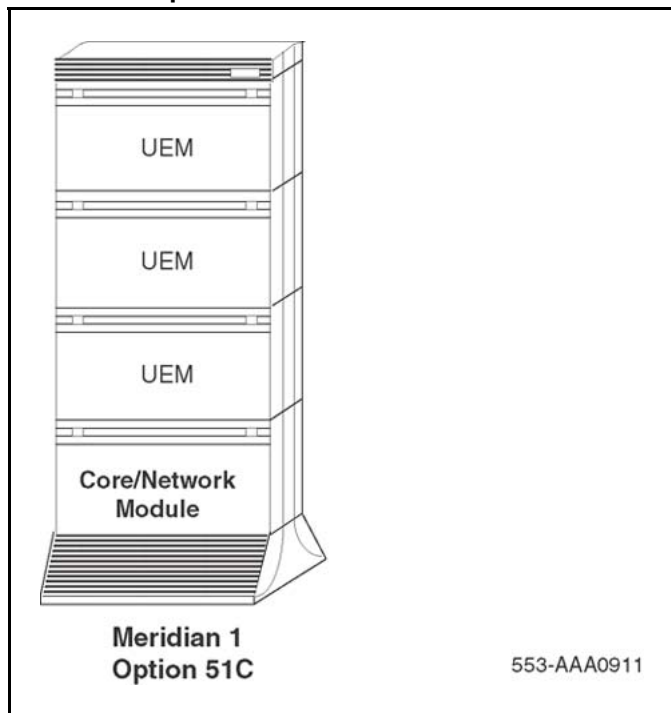

Figure 2
CS 1000M HG

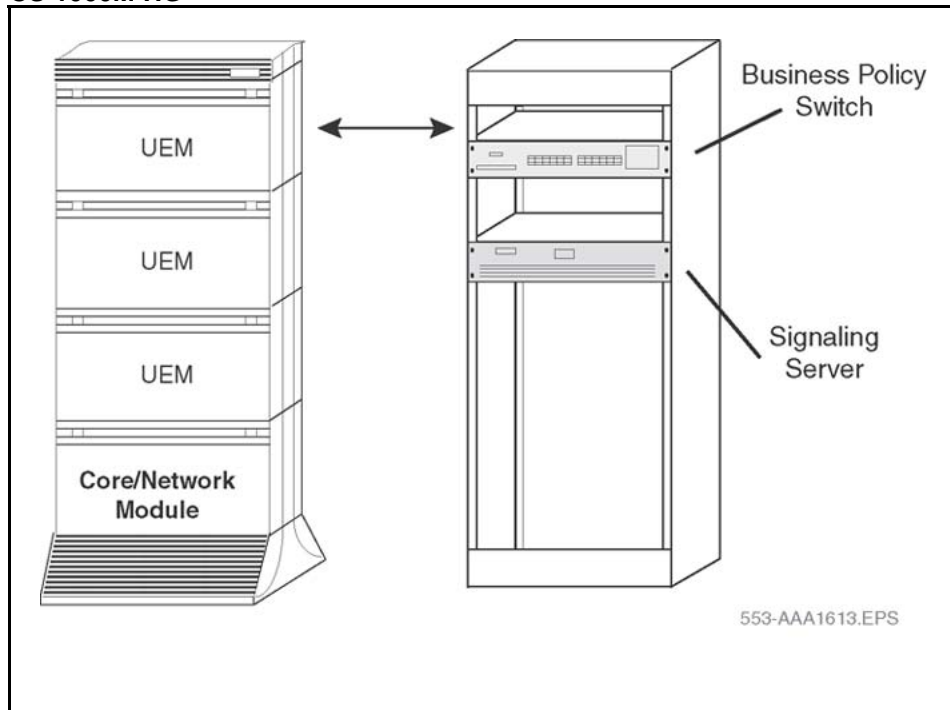

Table 2
Specifications for CS 1000M HGand Meridian 1 Option 51C

System characteristics:	
Maximum number of ports	<ul style="list-style-type: none"> • 1000
Input voltage	<ul style="list-style-type: none"> • 208 V AC or –48 V DC
Number of CPUs	<ul style="list-style-type: none"> • 1
Number of network loops	<ul style="list-style-type: none"> • 16
Memory options:	
Release 25	<ul style="list-style-type: none"> • NT5D10 CP or NT5D03 CP card
Succession 3.0	<ul style="list-style-type: none"> • CP3 NT5D10 CP or CP4 NT5D03 card
CS 1000 Release 4.5	<ul style="list-style-type: none"> • CP3 NT5D10 CP or CP4 NT5D03 card
Software generic	<ul style="list-style-type: none"> • 2811
Base hardware:	
Core/Network module	<p>Required per system:</p> <ul style="list-style-type: none"> • SDI-type card <p>Required per module:</p> <ul style="list-style-type: none"> • CE power supply (CEPS) • Call Processor (CP) card • Input/Output Disk Unit with CD-ROM (IODU/C) • Core to Network Interface (cCNI) card • 3-Port Extender (3PE) card • Clock Controller Card (MCLK)
IPE module	<ul style="list-style-type: none"> • IPE power supply • IPE cards
Pedestal (one per column)	<ul style="list-style-type: none"> • System Monitor • PDU • Blower unit

Table 2
Specifications for CS 1000M HGand Meridian 1 Option 51C (cont'd.)

Top cap (one per column)	<ul style="list-style-type: none">• Thermostat harness• Air probe harness
--------------------------	--

CS 1000M SGand Meridian 1 PBX 61C CP PIV

The CS 1000M SGand the Meridian 1 PBX 61C CP PIVare dual-CPU systems with standby processing capability, fully redundant memory, and a full-network group. Two cPCI Core/Network modules and one IPE module are required. Additional IPE modules and application modules can be used.

[Figure 3 "Meridian 1 PBX 61C CP PIVor Meridian 1 Option 61C"](#) (page 18) illustrates an Option 61C or Meridian 1 PBX 61C CP PIV.

With the addition of a Signaling Server, Option 61C or Meridian 1 PBX 61C CP PIVbecomes CS 1000M SG. [Figure 4 "CS 1000M SG"](#) (page 19) illustrates a CS 1000M SG.

Figure 3
Meridian 1 PBX 61C CP PIVor Meridian 1 Option 61C

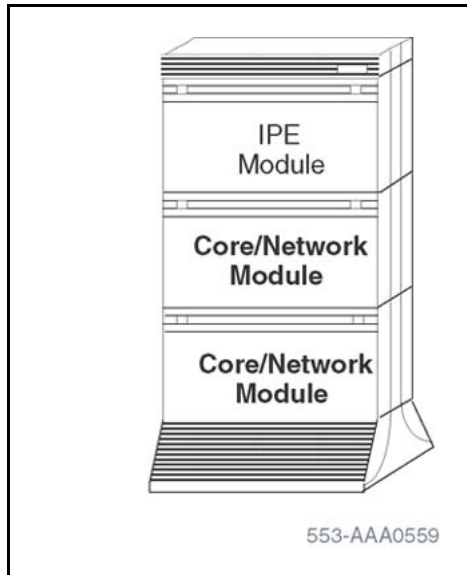

Figure 4
CS 1000M SG

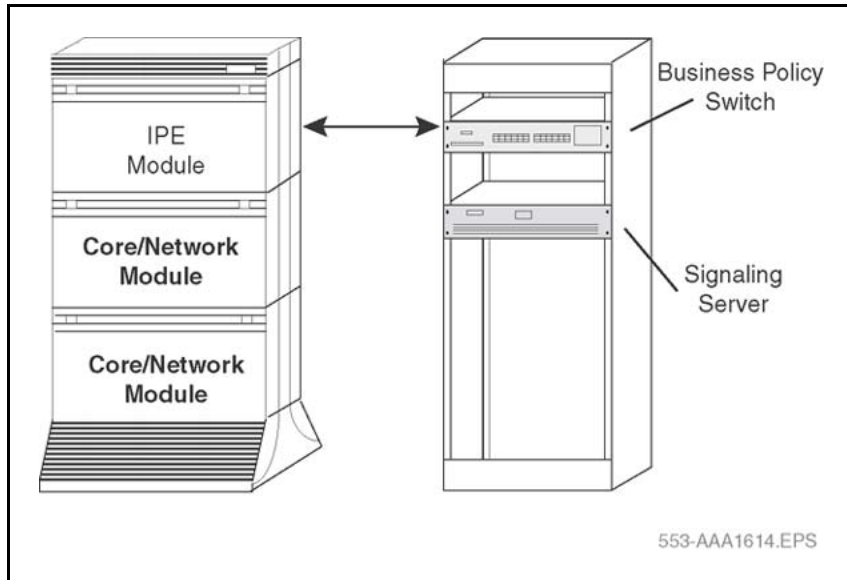

Table 3 "Specifications for CS 1000M SG and Meridian 1 PBX 61C CP PIV" (page 19) lists the specifications for CS 1000M SG and Meridian 1 PBX 61C CP PIV.

Table 3
Specifications for CS 1000M SG and Meridian 1 PBX 61C CP PIV

System characteristics:	
Maximum number of ports	• 2000
Input voltage	• 208 V AC or -48 V DC
Number of CPUs	• 2 (redundant)
Number of network loops	• 32
Memory options:	
Release 25	• NT5D10 CP or NT5D03 CP card
Succession 3.0	• CP3 NT5D10 or CP4 NT5D03 card
CS 1000 Release 4.5	• CP3 NT5D10 or CP4 NT5D03 card
Software generic	• 2911
Base hardware:	

Table 3
Specifications for CS 1000M SGand Meridian 1 PBX 61C CP PIV (cont'd.)

Core/Network module (two)	<p>Required per system:</p> <ul style="list-style-type: none"> • SDI-type card <p>Required per module:</p> <ul style="list-style-type: none"> • Call Processor Pentium II® (CP PIV) card • System Utility (Sys Util) card • Core to Network Interface (cCNI) card • 3-Port Extender (3PE) card • Peripheral Signaling card (PS) • Network cards • Superloop Network cards • Conference/TDS card • CE power supply • Hybrid Bus Terminators <p>Cards in the back of the module:</p> <ul style="list-style-type: none"> • System Utility Transition (Sys Util Trans) card • cCNI Transition (cCNI Trans) card
IPE module	<ul style="list-style-type: none"> • IPE power supply • IPE cards • Controller card
Pedestal (one per column)	<ul style="list-style-type: none"> • System Monitor • PDU • Blower unit
Top cap (one per column)	<ul style="list-style-type: none"> • Thermostat harness • Air probe harness

CS 1000M MGand Meridian 1 PBX 81C CP PIV

The CS 1000M MGand Meridian 1 PBX 81Care dual-CPU systems with standby processing capabilities, fully-redundant memory, and up to eight full network groups. These systems are equipped with two redundant input/output processor and disk drive unit combination packs.

The following modules are required:

- two Core/Network modules (provides one network group)
- a minimum of two Network modules (provides one network group)
- a minimum of one IPE module

Additional Network and IPE modules are required for additional network groups. Application modules can also be used.

Figure 5 "Meridian 1 PBX 81C CP PIVor Option 81C" (page 21) shows a typical configuration for eight full network groups. Additional columns can be added, and there can be more than one row of columns.

With the addition of a Signaling Server, Meridian 1 Option 81C or Meridian 1 PBX 81C CP PIVbecomes a CS 1000M MG. Figure 6 "CS 1000M MG" (page 22) illustrates the CS 1000M MG.

Figure 5
Meridian 1 PBX 81C CP PIVor Option 81C

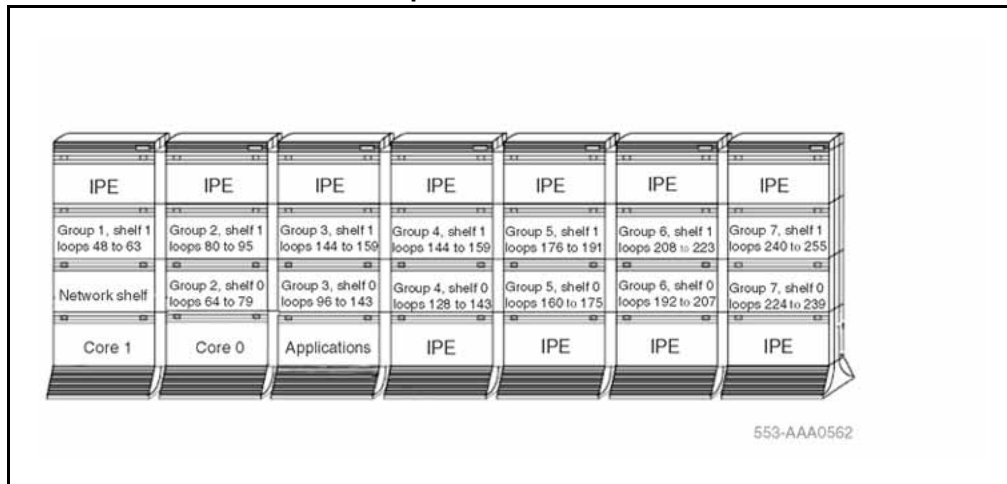

Figure 6
CS 1000M MG

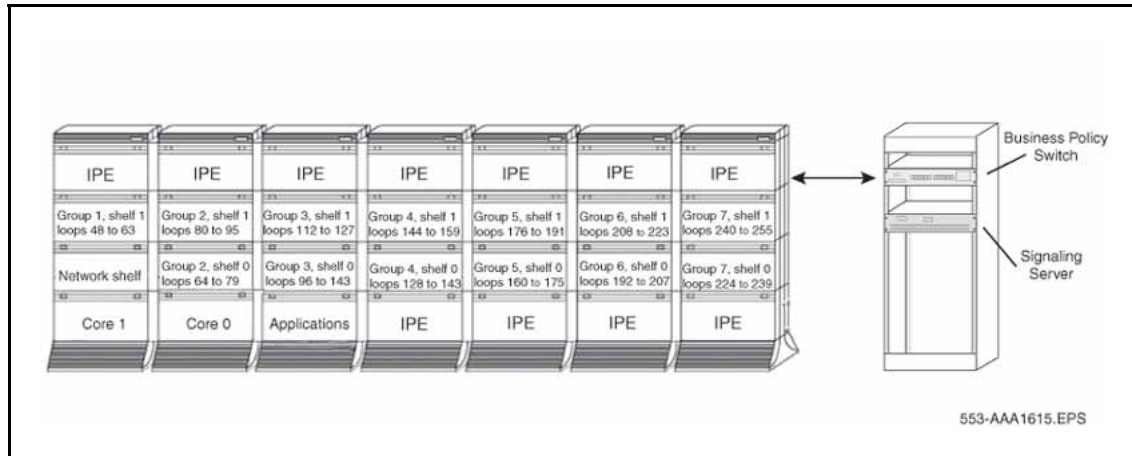

Table 4 "Specifications for CS 1000M MG and Meridian 1 Option 81C CP PIV" (page 22) lists specifications for the Meridian 1 PBX 81C CP PIV.

Table 4
Specifications for CS 1000M MG and Meridian 1 Option 81C CP PIV

System characteristics:	
Maximum number of ports	<ul style="list-style-type: none"> • 10 000
Input voltage	<ul style="list-style-type: none"> • 208 V AC or -48 V DC
Number of CPUs	<ul style="list-style-type: none"> • 2 (redundant)
Number of network loops	<ul style="list-style-type: none"> • 256
Memory	<ul style="list-style-type: none"> • 128 MB • 256 MB • CP3 NT5D10, required for CS 1000 Release 4.5 • CP4 NT5D03, required for CS 1000 Release 4.5
Base hardware:	

Table 4
Specifications for CS 1000M MGand Meridian 1 Option 81C CP PIV (cont'd.)

cCPI Core/Network module (two side-by-side)	<p>Cards in the front of the module:</p> <ul style="list-style-type: none"> • Call Processor Pentium IV® (CP PIV) card • System Utility (Sys Util) card • Core to Network Interface (cCNI) cards • 3-Port Extender (3PE) card • Peripheral Signaling card (PS) • Fiber Junctor Interface (FIJI) card • Network cards • Superloop Network cards • Conference/TDS card • CE power supply • Hybrid Bus Terminators
IPE module	<p>Cards in the back of the module:</p> <ul style="list-style-type: none"> • System Utility Transition (Sys Util Trans) card • cCNI Transition (cCNI Trans) cards • Superloop Network card • Clock Controller card • SDI-type card • DDP2 pack • MSDL • IPE power supply • Controller card • IPE cards

Table 4
Specifications for CS 1000M MGand Meridian 1 Option 81C CP PIV (cont'd.)

Pedestal (one per column)	<ul style="list-style-type: none">• System monitor• Power Distribution Unit (PDU)• Blower unit
Top cap (one per column)	<ul style="list-style-type: none">• Thermostat harness• Air probe harness

System modules

Each type of module is available in AC-powered and DC-powered versions (except the NT8D36 InterGroup module that does not require power). AC-power modules generally require a module power distribution unit (MPDU) to provide circuit breakers for the power supplies. DC-powered modules do not require an MPDU because a switch on each power supply performs the same function as the MPDU circuit breakers.

Note: In the UK, DC-powered modules must be used.

The figures in this chapter show a typical configuration for each module. DC power is represented in these examples.

NT4N41 Core/Network module

This module provides common control and network interface functions. With the CS 1000M MGand the Meridian 1 PBX 81C CP PIV, two Core/Net modules are installed side-by-side. With the CS 1000M SGand the Meridian 1 PBX 61C CP PIV, the modules are stacked or mounted side-by-side.

One section of this module houses the common control complex (CPU, memory, up to four cCNI cards, and mass storage functions). The other section supports a Conference card, one Peripheral Signaling card, one 3-Port Extender card, and optional network cards.

Note: cCNI card slots 13 and 14 remain empty.

Each Core/Network module houses up to four NT8D04 Superloop Network Cards for a total of 16 network loops. Superloop Network cards are cabled to the backplane of an IPE module. In a typical configuration, one conference/TDS card is configured in the module, leaving 14 voice/data loops available.

Figure 7 "NT4N41 cPCI Core/Network module" (page 25) illustrates an NT4N41 Core/Network module.

Core side

The Core side of the module contains the circuit cards that process calls, manage network resources, store system memory, maintain the user database, and monitor the system. These circuit cards also provide administration interfaces through a terminal, modem, or enterprise IP network.

The Core side runs in redundant mode: one Core operates the system while the other runs diagnostic checks and remains ready to take over if the active Core fails. Both Cores are connected to each Network group depending on hardware configuration. If one Core fails, the second Core immediately takes over call processing. The Core shelf backplane is a compact PCI data bus.

Figure 7
NT4N41 cPCI Core/Network module

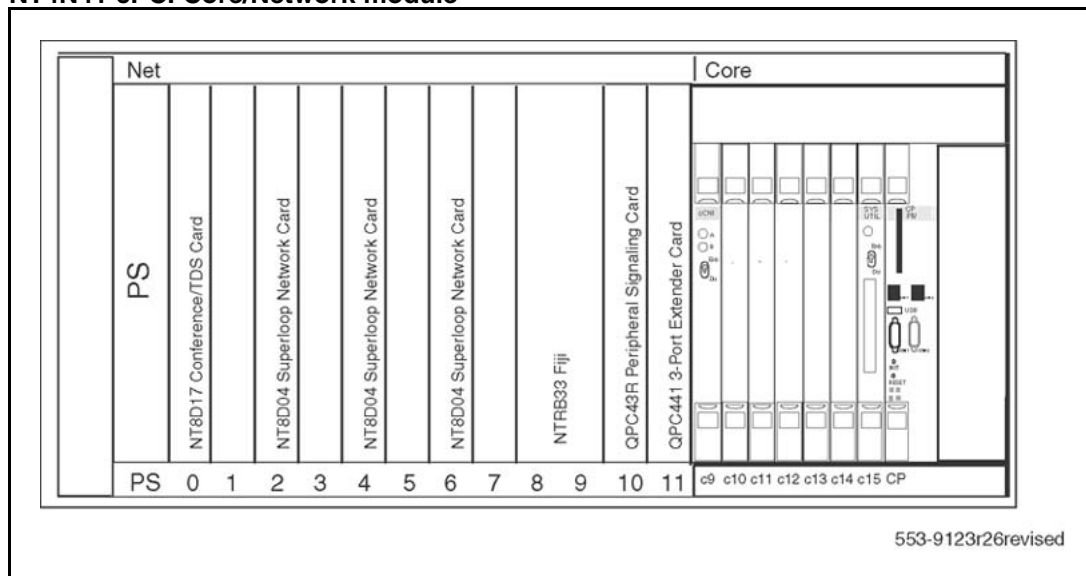

Network side

The Network side of this module contains the cards for half of the Network group 0. The other half of Network group 0 resides in the second core network module.

The CS 1000M MG and Meridian 1 PBX 81C CP PIV support a Fiber Network Fabric network system with a FIJI card. The double slot FIJI (NTRB33AF) card is installed in slots 8 and 9 on the Net side of the Core/Net module, while the single slot FIJI (NTRB33BBE5) card is installed in slot 9 on the Net side of the Core/Net module.

The double slot FIJI (NTRB33AF) card is installed in slots 2 and 3 on the Network module, while the single slot FIJI (NTRB33BBE5) card is installed in slot 2 on the Network module.

NT5D21 Core/Network module

This module provides common control and network interface functions in CS 1000M SG, CS 1000M MG, CS 1000M HG, Meridian 1 Option 51C, Meridian 1 Option 61C, and Meridian 1 Option 81C.

Two Core/Network modules are required in the CS 1000M SG, CS 1000M MG, Meridian 1 Option 81C, and Meridian 1 Option 61C systems to provide redundant common control operation. If a failure occurs in one module, the function is transferred to the appropriate circuit cards in the other module without a loss of service. One Core/Network module is required in the CS 1000M HG or Option 51C system.

One section of this module houses the common control complex (CPU, memory, up to three CNI cards, and mass storage functions). The other section supports a Conference card, one Peripheral Signaling card, one 3-Port Extender card, and optional network cards.

Note: CNI card slots 13 and 14 remain empty.

Each Core/Network module houses up to four NT8D04 Superloop Network Cards for a total of 16 network loops. Superloop Network cards are cabled to the backplane of an IPE module. In a typical configuration, one conference/TDS card is configured in the module, leaving 14 voice/data loops available.

[Figure 8 "NT5D21 Core/Network module" \(page 27\)](#) shows the cards housed in the NT5D21 Core/Network module as configured for Meridian 1 Option 61C.

Figure 8
NT5D21 Core/Network module

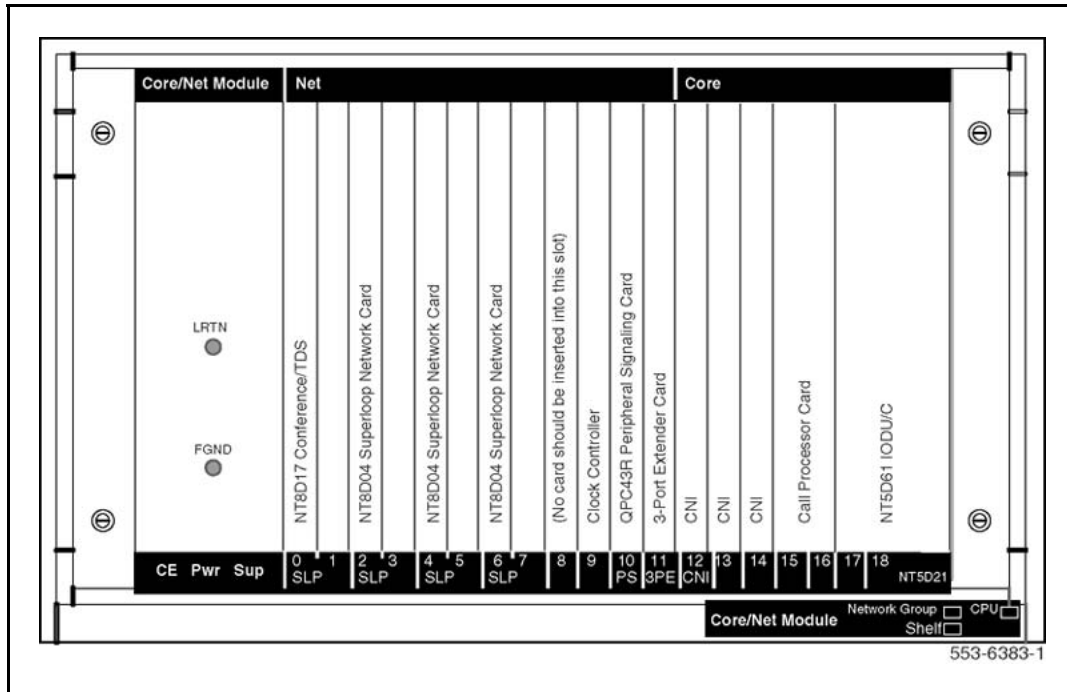

NT8D35 Network module

This module provides the network switching functions in the Meridian 1 Option 81C, Meridian 1 PBX 81C CP PIV, and CS 1000M MG.

Two Network modules are required to make a full network group of 32 loops. A maximum of 16 Network modules (eight network groups) can be configured in the Meridian 1 Option 81C, CS 1000M MG, and Meridian 1 PBX 81C CP PIV.

The Network module houses up to four NT8D04 Superloop Network Cards, for a total of 16 network loops. Superloop network cards are cabled to the backplane of an IPE module. In a typical configuration, one Conference/TDS card is configured in the module, leaving 14 voice/data loops available. In CS 1000M MG and Meridian 1 PBX 81C CP PIV, the Conference/TDS cards are located in the Core/Network module. The Clock Controller must be installed in slot 13.

[Figure 9 "NT8D35 Network module" \(page 28\)](#) shows the cards housed in the module.

Figure 9
NT8D35 Network module

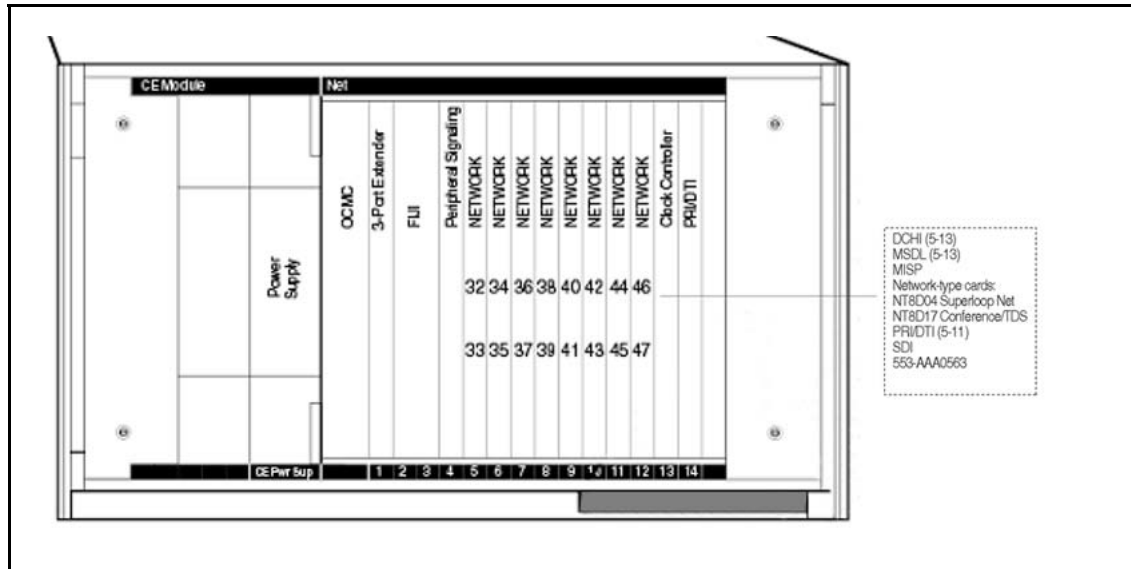

The Network module can be used as a PRI/DTI expansion module. The number of PRI/DTI expansion modules that can be used is determined by traffic considerations. [Figure 10 "NT8D35 Network module configured for PRI/DTI expansion" \(page 29\)](#) shows the card slot configuration when the Network module is used for PRI/DTI expansion.

Note: The bus terminating units (BTUs) that are equipped in the NT8D35AA and NT8D35DC Network module configuration are not required for, and will interfere with, the PRI/DTI expansion configuration. The NT8D35BA and NT8D35EA Network modules do not use or need BTUs for any application.

Figure 10
NT8D35 Network module configured for PRI/DTI expansion

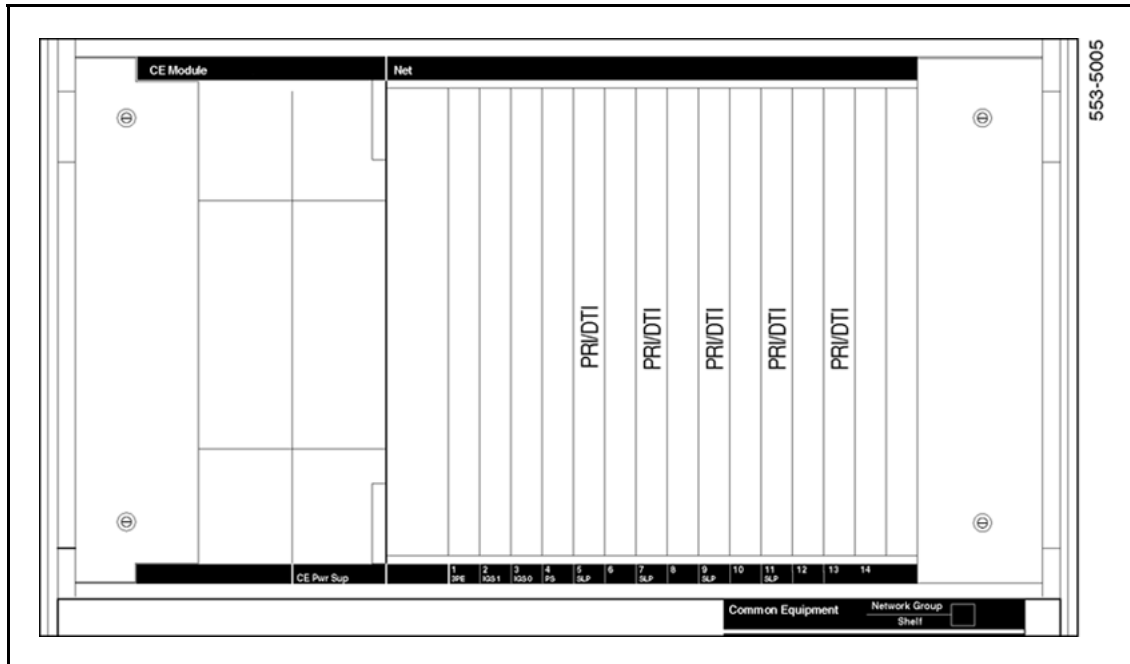

Fiber Network Fabric

Fiber Network Fabric extends and enhances the five-group network architecture to 8 non-blocking (inter-group) Network groups, with a resulting expansion in network capacity to 8000 timeslots available for Intergroup traffic. The Meridian 1 PBX 61C CP PIV can be upgraded to a Meridian 1 PBX 81C CP PIV with Fiber Network Fabric. This upgrade takes a Meridian 1 PBX 61C CP PIV to a Meridian 1 PBX 81C CP PIV with two groups. [Figure 11 "Four group Fiber Network Fabric configuration" \(page 30\)](#) illustrates a four group configuration of Fiber Network Fabric.

Figure 11
Four group Fiber Network Fabric configuration

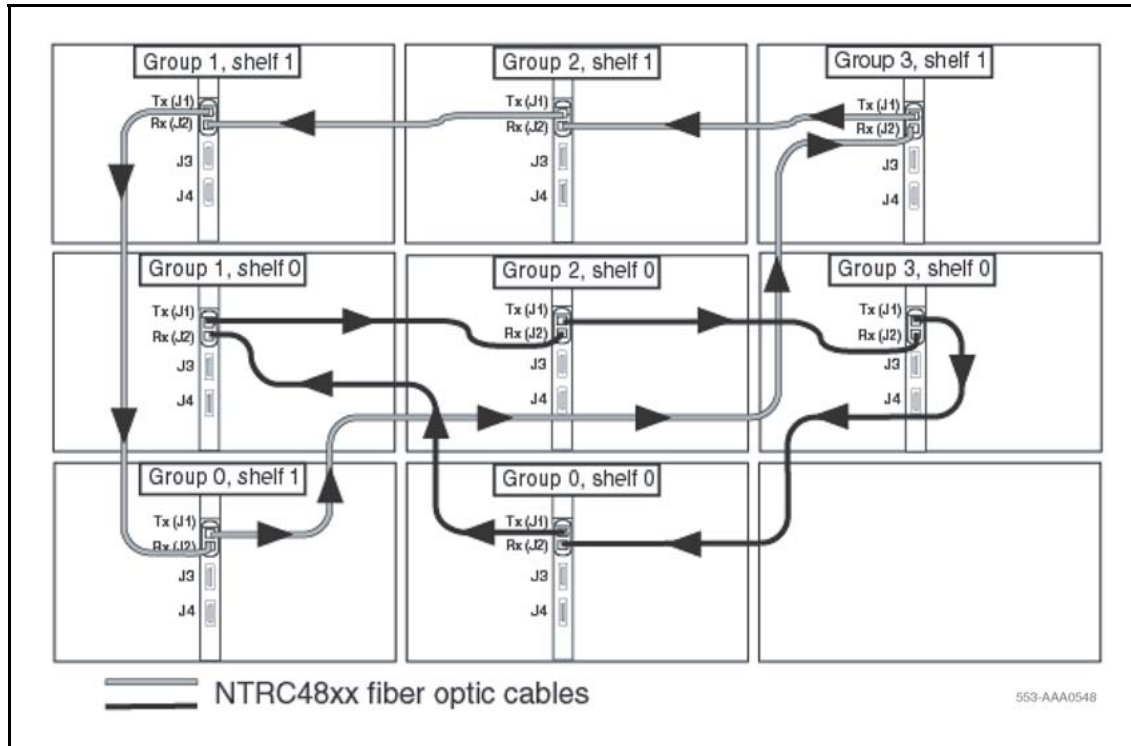

NT8D37 Intelligent Peripheral Equipment module

The Intelligent Peripheral Equipment (IPE) module provides the interface between network switching and IPE cards, such as intelligent line and trunk cards, in all Large Systems.

The IPE module houses one NT8D01 Controller Card, which is the peripheral equipment controller, and up to 16 IPE cards, supporting up to 512 terminal numbers (256 voice and 256 data). The controller card is cabled to the NT8D04 Superloop Network Card.

Figure 12 "NT8D37 IPE module" (page 31) shows the card slot assignments in the module.

Figure 12
NT8D37 IPE module

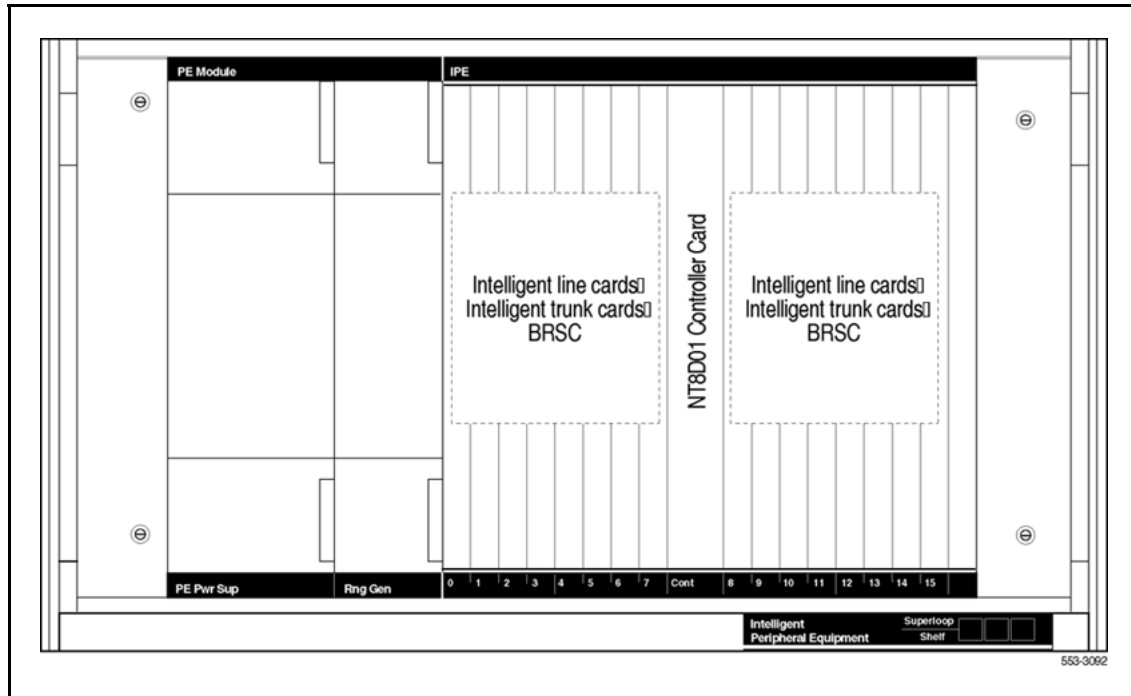

Fiber Remote IPE module

This module provides fiber-optic links between the network functions in a Large System and the peripheral controller functions in the Fiber Remote IPE. A floor-standing column or wall-mounted cabinet is installed at the remote site and is connected to the Large System using fiber-optic links.

The Fiber Remote IPE provides Large Systems functionality with the installation of only IPE modules and IPE cards at a distant site. Since the remote IPE system uses the common equipment and network equipment of the associated local Large System, it can deliver the same features and functionality as the local system. See [“Fiber Remote IPE” \(page 58\)](#) for more information on the Fiber Remote IPE configuration option.

Carrier Remote IPE

The Carrier Remote IPE provides functionality by installing only IPE modules and IPE cards at a distant site. The Remote IPE shares the system common and network equipment to provide the same functions and features to remote subscribers that are available to local system subscribers.

See [“Carrier Remote IPE” \(page 61\)](#) for more information on the Carrier Remote IPE configuration option.

System architecture

Contents

This section contains information on the following topics:

- “Hardware architecture” (page 34)
 - “Common control complex” (page 35)
 - “Network interface” (page 39)
 - “Intelligent Peripheral Equipment” (page 43)
 - “Terminal equipment” (page 46)
 - “Power equipment” (page 47)
 - “Signaling Server” (page 49)
- “Software architecture” (page 55)
 - “Firmware” (page 56)
 - “Software” (page 56)
 - “Office data” (page 56)
 - “Resident programs” (page 56)
 - “Nonresident programs” (page 57)
- “Configuration options” (page 58)
 - “Fiber Remote IPE” (page 58)
 - “Carrier Remote IPE” (page 61)
 - “Branch Office” (page 62)
 - “Geographic Redundancy” (page 62)

Hardware architecture

CS 1000M and Meridian 1 systems are circuit-switched digital systems that provide voice and data transmission. The internal hardware is divided into the following functional areas (see [Figure 13 "Large System basic architecture" \(page 35\)](#) on [Figure 13 "Large System basic architecture" \(page 35\)](#)):

- Common Control Complex (Common Equipment) circuit cards provide the processor control, software execution, and memory functions of the system.
- Network Interface (Common Equipment) circuit cards perform switching functions between the processor and Intelligent Peripheral Equipment (IPE) cards.

Note: As shown in [Figure 13 "Large System basic architecture" \(page 35\)](#), the network interface function is generally considered a subset of the Common Equipment functions.

- IPE circuit cards provide the interface between the network and connected devices, including Terminal Equipment and trunks.
- Terminal Equipment includes telephones and attendant consoles (and may include equipment such as data terminals, printers, and modems).
- Power Equipment provides the electrical voltages required for system operation and cooling, and sensor equipment for system protection.

Figure 13
Large System basic architecture

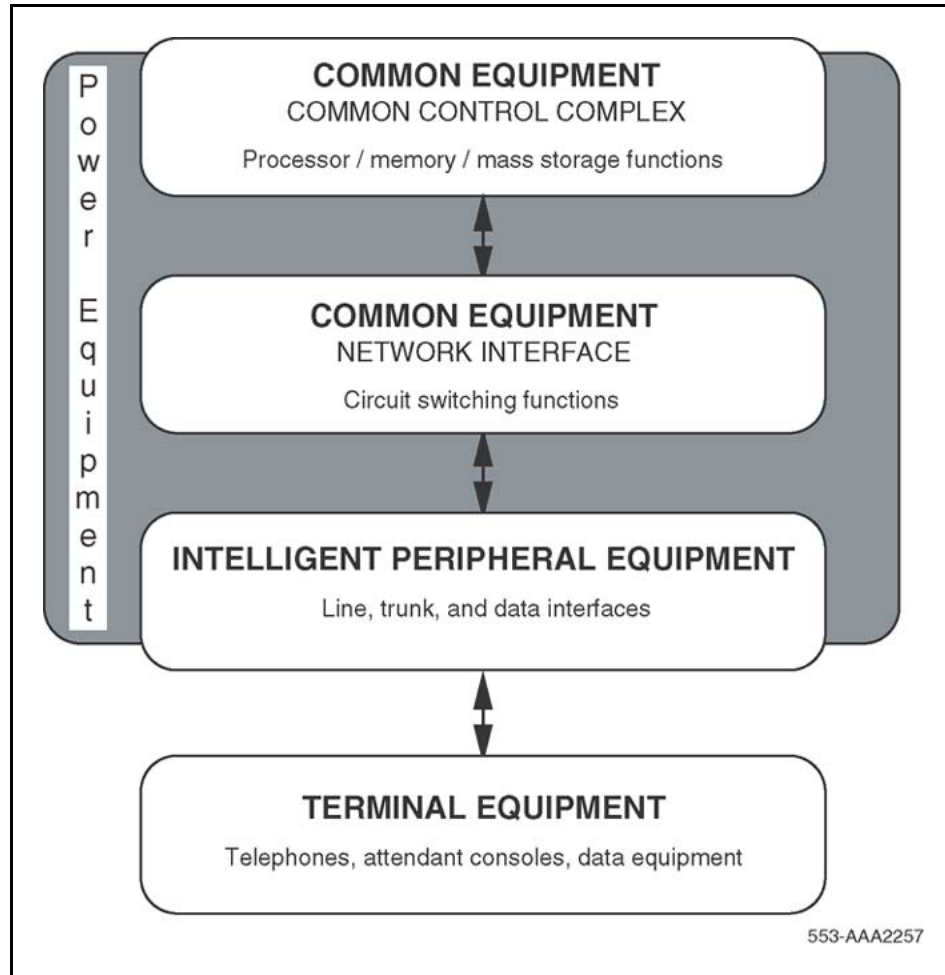

Common control complex

The processor is the common control complex of the system. It provides the sequences to process voice and data connections, monitor call activity, and perform system administration and maintenance.

The processor communicates with the network interface over a common control bus that carries the flow of information.

The common control complex consists of:

- the processor card or cards that provide the computing power for system operation
- system memory that stores all operating software programs and data unique to each system

- the disk drive unit that provides mass storage for operating programs and data
- I/O interfaces that provide an information exchange between the user and the system

CS 1000M and Meridian 1 "core" processor cards support extensive networking and provide intensive use of software features and applications, including call centers of up to 1000 agents.

The core software architecture incorporates a real-time multitasking operating system, as well as code that delivers features and call processing. This architecture guarantees feature transparency to the user upgrading the core CPU. The core architecture also provides significant operation, administration, and maintenance enhancements for the people who work closely with the system software and hardware.

All core overlays reside in Dynamic Random Access Memory (DRAM) after they are loaded from the hard disk during an initial software load (software is shipped on redundant hard disks). The Resident Overlays featured in core-based systems ensure subsecond speeds in accessing the overlays.

The capacity enhancement in the core architecture is provided by the core control complex. In Large Systems with cPCI Core/Network modules, the core control complex refers to the two Core/Network modules (Core/Network 0 and Core/Network 1). The Core and Core/Network modules are fully redundant, with Core 1 duplicating the contents of Core 0.

The backplane in the CS 1000M MGand Meridian 1 PBX 81C CP PIVCore modules is a compact Peripheral Component Interconnect (PCI) data bus. PCI provides a high-speed data path between the CPU and peripheral devices. PCI runs at 33MHz, supports 32- and 64-bit data paths and bus mastering.

The backplane in the system is divided into "core" and "network" sides. The "network" side allows up to eight network cards to be installed for call processing capability.

In the CS 1000M HGand Option 51C Core/Network module, the core side houses the following equipment:

- one Call Processor (CP) card
- one Input/Output Disk Unit with CD-ROM (IODU/C)
- one Core-to-Network Interface (CNI or CNI-3) card

In the CS 1000M SGand Meridian 1 PBX 61C CP PIVCore/Network module, the core side houses the following equipment:

- one Call Processor Pentium IV® (CP PIV) card
- one System Utility (Sys Util) card
- one Core-to-Network Interface (cCNI) cards
- one System Utility Transition (Sys Util Trans) card
- four cCNI Transition (cCNI Trans) cards

Cabling between the CP cards allows memory shadowing and dual-CPU operation.

The CNI and CNI-3 cards provide the interface between the IPB and the network shelf, and between the CP card and three-port extender cards in the network shelf. Each CNI card provides two ports. Each CNI-3 card supports three ports. In a typical configuration, three CNI-3 cards support eight network groups.

Software is now installed with 2 Compact Flash cards: one embedded on the CP PIV pack (FMD) 1GB, and one hot swappable (RMD) with 512 MB.

The system uses a Security Device and an electronic Keycode to perform security authentication. The security device is located on the utility card. The Keycode file contains information about which features the system provides as well as License limits.

Core/Net modules diagnose faults in field-replaceable units for all core hardware, including cables. In case of a failure, a message appears on the system terminal and on the Liquid Crystal Display (LCD) of the CP card. All messages can be stored in a file for future diagnostics.

[Figure 14 "CS 1000M SGand Meridian 1 PBX 61C CP PIVcore complex" \(page 38\)](#) provides a block diagram of the CS 1000M SGand Meridian 1 PBX 61C CP PIVcore architecture.

In the CS 1000M MGand Meridian 1 PBX 81CcPCI Core/Network module, the core side houses the following equipment:

- one Call Processor Pentium IV® (CP PIV) card
- one System Utility (Sys Util) card
- up to four Core to Network Interface (cCNI) cards
- one System Utility Transition (Sys Util Trans) card
- four cCNI Transition (cCNI Trans) cards

Core/Net modules diagnose faults in field-replaceable units for all core hardware, including cables. In case of a failure, a message appears on the system terminal and on the LCD of the faceplate of the utility card.

Core to Core Ethernet connection (LAN1 to LAN2) between the CP PIV cards allows memory shadowing and dual-CPU operation.

The cCNI Transition cards connect the Core module cards to the 3PE cards in the Network modules. Each Core module contains between one and four cCNI cards. Since each cCNI card can connect up to two Network groups, each Core is connected to a minimum of two groups and a maximum of eight groups. The number of cCNI cards in a system depends on the number of Network groups in that system. The first cCNI card that connects to Network group 0 and group 1 is installed in slot c9 of each Core/Net module. Each additional cCNI card is installed in ascending order from slots c10 to c12.

Figure 14
CS 1000M SGand Meridian 1 PBX 61C CP PIVcore complex

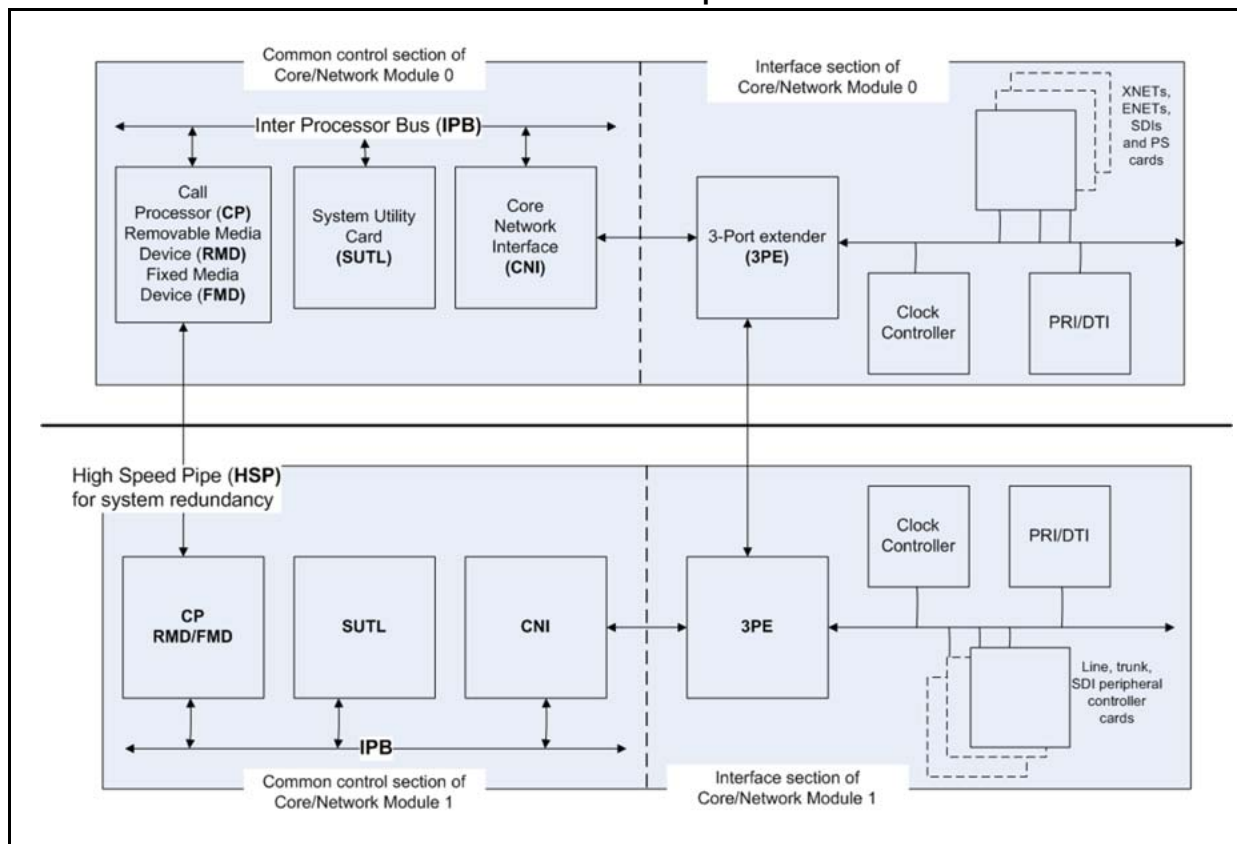

The System Utility card supports Card ID. The card provides an interface between the security device and the computer, and an interface between the XSM and display panel for each Core/Net card cage. This card also includes a switch on the faceplate to enable or disable the Core cards.

The System Utility Transition card provides connections for the security device, the system monitor, and the status panel. This Transition card is mounted on the rear of the backplane (back side) directly behind the System Utility card.

The cCNI Transition cards provide the cable connections to the 3PE Termination Panel at the back of the module. A cCNI Transition card is mounted directly behind each cCNI card (on the back of the Core backplane). Four cCNI Transition cards for Core/Net module are installed in the factory regardless of how many cCNI main cards are configured for the system.

Network interface

Network switching, based on digital multiplexed loops, interconnects peripheral ports. A loop transmits voice, data, and signaling information over a bidirectional path between the network and peripheral ports.

Network cards digitally transmit voice and data signals, using space switching and Time Division Multiplexing (TDM) technology. Network switching also requires service loops (such as conference and TDS loops), which provide call progress tones and outpulsing.

The following cards provide basic network switching control:

- The NT8D04 Superloop Network card provides switching for four loops grouped together in an entity called a superloop.
- The NT5D12 Digital Trunk card provides switching for two DTI/PRI loops and takes one network slot.
- The NT5D97 Digital Trunk card provides switching for two DTI2/PRI2 loops and takes one network slot.

The NT5D12 and NT5D97 Digital Trunk cards replace the functionality of the QPC720 DTI/PRI and QPC414 Network card, which provided switching for two loops.

Network organization

Network loops are organized into groups. A system is generally configured as one of the following:

- a half group system (CS 1000M HG) that provides up to 16 loops
- a single group system (CS 1000M SG) that provides up to 32 loops
- a multi-group system (CS 1000M MG) that provides up to 256 loops

The Fiber Junctor Interface (FIJI) cards in the Network modules are connected with fiber-optic cables to form a Dual Ring Fiber Network. This network consists of two separate rings: one ring connects all the Network shelf 0s while the second ring connects all the Network shelf 1s. This network communicates on a subset of the Sonet OC12c protocol (622 MB bandwidth on each ring).

The Dual Ring fiber-optic cable configuration provides complete non-blocking communication between the Network groups; this eliminates the incidence of busy signals for calls switched between groups. Each FIJI card can handle 32 PCM links. A system of eight Network groups provides 8000 timeslots for 4000 simultaneous conversations.

This Dual Ring network is fully redundant: each of the fiber-optic cable rings is capable of handling the traffic for an entire eight group network. If a fault in one ring is detected, the other ring automatically takes over call processing. No calls are lost during the switchover.

The Dual Ring Fiber network operated under four states:

- Normal
 - Traffic is shared between the two rings.
 - Each FIJI card drives 480 timeslots.
- Full
 - Traffic is handled by a single ring.
 - Each FIJI card drives 960 timeslots
- Survival
 - FIJI cards in both rings are used to maintain intergroup traffic.
- Disabled
 - The ring is inactive and does not support call processing.

Superloop network configurations

By combining four network loops, the superloop network card makes 120 timeslots available to IPE cards. Compared to regular network loops, the increased bandwidth and a larger pool of timeslots increases network traffic capacity for each 120-timeslot bundle by 25 percent (at a P0.1 grade of service).

The NT8D37 IPE module is divided into segments numbered 0–3 of four card slots each (see [Figure 15 "Superloop segments in the IPE module" \(page 41\)](#)). Segment 0 consists of slots 0–3, segment 1 consists of slots 4–7, segment 2 consists of slots 8–11, and segment 3 consists of slots 12–15.

Figure 15
Superloop segments in the IPE module

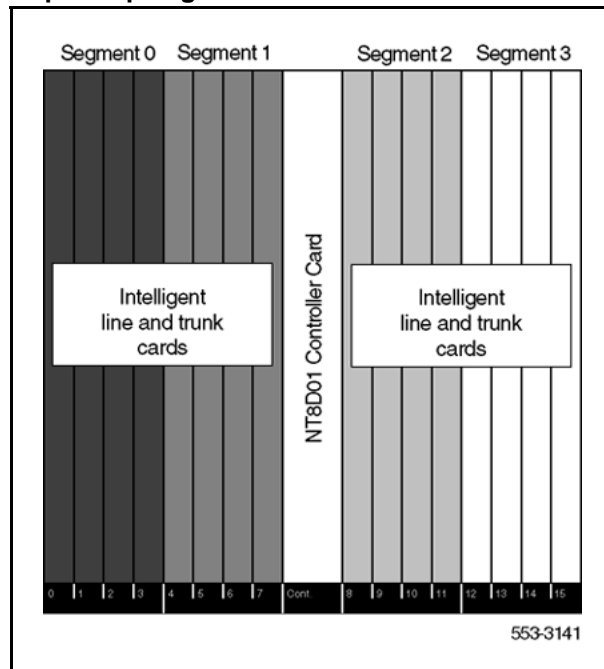

A superloop is made up of NT8D04 Superloop Network cards, NT8D01AC or NT8D01BC Controller-4 or NT8D01AD Controller-2 cards, and from one to eight IPE segments. The NT8D01BC Controller-4 replaces the NT8D01AC and NT8D01AD Controller cards for replacements and new installations.

A number of superloop-to-segment configurations are possible:

- one segment per superloop requires four superloop network cards and one controller-4 card
- two segments per superloop requires two superloop network cards and one controller-2 card

- four segments per superloop requires one superloop network card and one controller-2 card
- eight segments per superloop requires one superloop network card and two controller-2 cards
- one segment per superloop/three segments on a second superloop requires two superloop network cards and one controller-2 card
- two segments per superloop/six segments on a second superloop requires two superloop network cards and two controller-2 cards

As an example of a superloop configuration, [Figure 16 "Eight segments per superloop" \(page 43\)](#) shows eight segments per superloop. If a segment in this configuration is equipped with analog line cards and trunk cards, a high concentration environment of 120 timeslots to 128–512 Terminal Numbers (TNs) is provided. If half of the data TNs on digital line cards are enabled, this configuration provides a concentration of 120 timeslots to 768 TNs.

For a detailed description of superloop-to-segment configurations, see *Communication Server 1000M and Meridian 1 Large System Planning and Engineering (NN43021-220)*, .

Figure 16
Eight segments per superloop

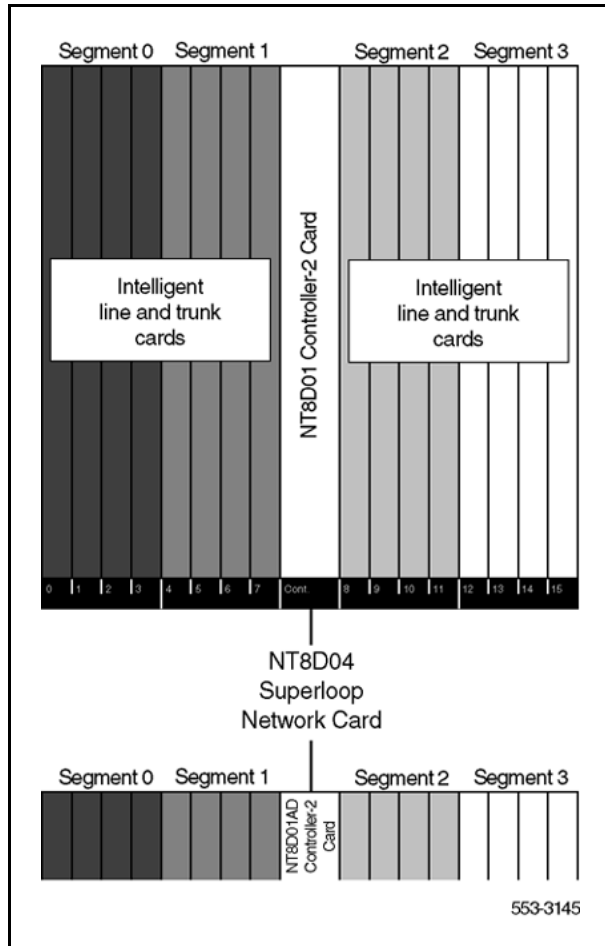

Intelligent Peripheral Equipment

Using pulse code modulation (PCM), Intelligent Peripheral Equipment (IPE) converts analog signals to digital signals before switching is performed by the network. This conversion method samples the amplitude of the analog signal at a rate of twice the highest signal frequency, then converts the amplitude into a series of coded pulses. For telecommunications, the PCM-sampling frequency standard is 8 kHz.

Compressing-expanding (companding) PCM is a standard technique for using 8-bit words to efficiently represent the range of voice and data signals. Two standards for companding, A-Law and μ -Law, are recognized worldwide. IPE conforms to both standards; the standard required is selected through software.

IPE is associated with network loops. IPE cards are supported by NT8D04 Superloop Network Card loops. The traffic requirements of all IPE cards provisioned on a particular network loop must match the traffic capacity of that loop.

IPE includes:

- controller cards that provide timing and control sequences and monitoring capabilities
- analog and digital line and trunk cards that provide interfaces to equipment outside the modules (such as telephones, data terminals, and trunks)

Table 5 "Intelligent Peripheral Equipment cards" (page 44) lists the IPE cards and the number of terminations each supports.

Table 5
Intelligent Peripheral Equipment cards

Intelligent Peripheral Equipment cards	Number of terminations
Controller cards:	
NT8D01 Controller Card-4	N/A
NT8D01 Controller Card-2	N/A
Line cards:	
NT1R20 OPS Analog Line card	8
NT5K02 Analog Line card	16
NT5K96 Analog Line card	16
NT8D02 Digital Line card	16 to 32
NT8D09 Analog Message Waiting Line card	16
Trunk cards:	
NT5K07 Universal Trunk card	8
NT5K17 Direct Dial Inward Trunk card	8
NT5K18 Extended CO Trunk card	8
NT5K19 E&M/2280 Hz Trunk card	4
NT5K36 Direct Inward/Direct Outward Dial card	4
NT5K70 Extended CO Trunk card	8
Note: Terminal number (TN) density per segment is 16 to 128 TNs, with 64 to 512 TNs per IPE module. The maximum TN density assumes all slots are equipped with NT8D02 Digital Line cards with 16 voice and 16 data TNs provisioned. A typical mix of line and trunk cards yields a nominal density of 64 TNs per segment, 256 TNs per IPE module.	

Table 5
Intelligent Peripheral Equipment cards (cont'd.)

Intelligent Peripheral Equipment cards	Number of terminations
NT5K71 Extended CO Trunk card	4
NT5K72 E&M Trunk card	4
NT5K82 Extended CO Trunk card	8
NT5K83 E&M Trunk card	4
NT5K84 Direct Inward Dial Trunk card	8
NT5K90 Extended CO Trunk card	8
NT5K93 Extended CO Trunk card	8
NT5K99 Extended CO Trunk card	8
NT8D14 Universal Trunk card	8
NT8D15 E&M Trunk card	4
NTAG03 Extended CO Trunk card	8
NTAG04 Extended CO/Direct Inward Dial card	8
NTAG36 Meridian Integrated Recorded Announcement card	8
NTCK16 Generic Extended Flexible CO card	8
Special:	
NT5K20 Extended Tone Detector card	8
NT5K48 Global Extended Tone Detector card	8
NT5K92 Direct Inward Dial Tester card	1
<p>Note: Terminal number (TN) density per segment is 16 to 128 TNs, with 64 to 512 TNs per IPE module. The maximum TN density assumes all slots are equipped with NT8D02 Digital Line cards with 16 voice and 16 data TNs provisioned. A typical mix of line and trunk cards yields a nominal density of 64 TNs per segment, 256 TNs per IPE module.</p>	

Intelligent Peripheral Equipment remote location

In a local operating environment, IPE can be housed up to 15.2 m (50 ft) from the Common Equipment. IPE installed in a remote location extends this range, allowing approximately 112.6 km (70 miles) between local and remote facilities.

This extension is achieved by converting multiplexed loop signals to a form compatible with the commonly used T-1 type digital transmission system. Refer to [Table 5 "Intelligent Peripheral Equipment cards" \(page 44\)](#) for a list of IPE cards for use at the remote site.

Any medium that conforms to the DS-1 format (1.544 Mbps) can be used to link local and remote sites, including digital microwave radio and fiber-optic transmission systems.

Terminal equipment

Large Systems support a wide range of telephones, including multiple-line and single-line telephones, as well as digital telephones with key and display functions and data transmission capabilities. A range of options for attendant call processing and message center applications is also available. In addition, a number of add-on devices are available to extend and enhance the features of telephones and consoles. Add-on devices include key/lamp modules, lamp field arrays, handsets, and handsfree units.

For more information refer to *Telephones and Consoles Fundamentals (NN43001-567)*, and *IP Phones Fundamentals (NN43001-368)*,).

Digital telephones

Analog-to-digital conversion takes place in the digital telephone itself, rather than in the associated Peripheral Line card. This eliminates attenuation, distortion, and noise generated over telephone lines. Signaling and control functions are also handled digitally. Time Compression Multiplexing (TCM) is used to integrate the voice, data, and signaling information over a single pair of telephone wires.

For applications where data communication is required, Meridian 1 digital telephones offer an integrated data option that provides simultaneous voice and data communication over single pair wiring to a port on a digital line card.

CS 1000M and Meridian 1 Large Systems supports telephones as described in:

- *IP Phones Fundamentals (NN43001-368)*,
- *Telephones and Consoles Fundamentals (NN43001-567)*,
- *WLAN Handsets Fundamentals (NN43001-505)*,
- *DECT Fundamentals (NN43120-114)*,

Attendant consoles

Meridian 1 attendant consoles provide high-volume call processing. Indicators and a 4 x 40 liquid crystal display (LCD) provide information required for processing calls and personalizing call answering. Loop keys and Incoming Call Indicator (ICI) keys allow the attendant to handle calls in sequence or to prioritize answering for specific trunk groups. An optional busy lamp field provides the attendant with user status.

Meridian attendant consoles support attendant message center options. The attendant console can be connected to a PC to provide electronic directory, dial-by-name, and text messaging functions. All call processing features can be accessed using the computer keyboard.

Power equipment

Large Systems provide a modular power distribution architecture.

Each column includes:

- a system monitor that provides:
 - power, cooling, and general system monitoring capabilities
 - error and status reporting down to the specific column and module
- circuit breaker protection
- a cooling system with forced air impellers that automatically adjusts velocity to meet the cooling requirements of the system
- backup capabilities

Each module includes:

- an individual power supply unit with shut-off (switch or breaker) protection
- a universal quick-connect power wiring harness that distributes input voltages and monitor signals to the power supply

All options are available in both AC-power and DC-power versions. The selection of an AC- or DC-powered system is determined primarily by reserve power requirements and existing power equipment at the installation site.

Although AC-powered and DC-powered systems have different internal power components, the internal architecture is virtually identical. AC- and DC-powered systems differ primarily in the external power components.

AC power

AC-powered systems require no external power components and can plug directly into commercial AC (utility) power. AC-powered systems are especially suitable for applications that do not require reserve power. They are also recommended systems that require reserve power with backup times ranging from 15 minutes to 8 hours.

If reserve power is required with an AC-powered system, an Uninterruptible Power Supply (UPS), along with its associated batteries (either internal or external to the unit), is installed in series with the AC power source (see [Figure 17 "ExternalAC-power architecture with reserve](#)

power" (page 48)). An AC-powered system that does not require long-term backup can benefit from a UPS with short-term backup because the UPS typically provides power conditioning during normal operation, as well as reserve power during short outages or blowouts.

Figure 17
External AC-power architecture with reserve power

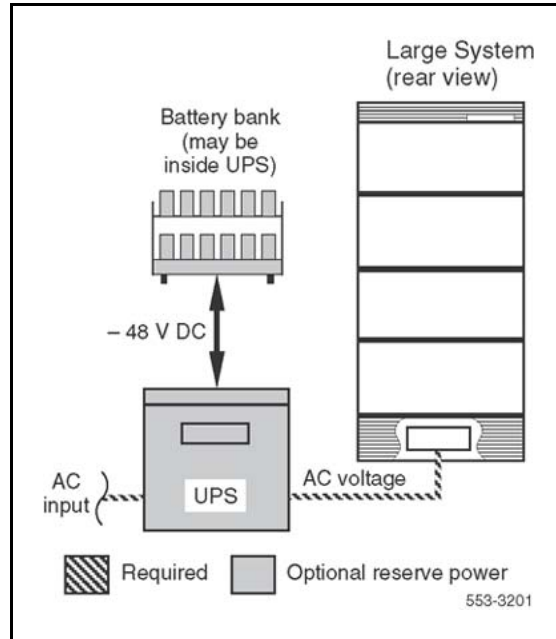

DC power

DC-powered systems always require external rectifiers to convert commercial AC power into the standard -48 V DC required within the system (see Figure 18 "External DC-power architecture with reserve power" (page 49)). Batteries are generally used with DC-powered systems, as the traditional telecommunications powering method is for the rectifiers to continuously charge a bank of batteries, while the system power "floats" in parallel on the battery voltage. However, batteries are only required if reserve power is needed.

A variety of rectifiers and distribution equipment can be used to supply external DC power. Existing customer equipment can be used or a system that Nortel either supplies or recommends, such as the Small or Large Candeco, can be used. The Small Candeco is appropriate for Single Group or Multi Group systems that do not require more than 300 A, while the Large Candeco is suitable for larger systems. In all cases, equipment for rectification and distribution is required, while reserve batteries are optional.

Figure 18
ExternalDC-power architecture with reserve power

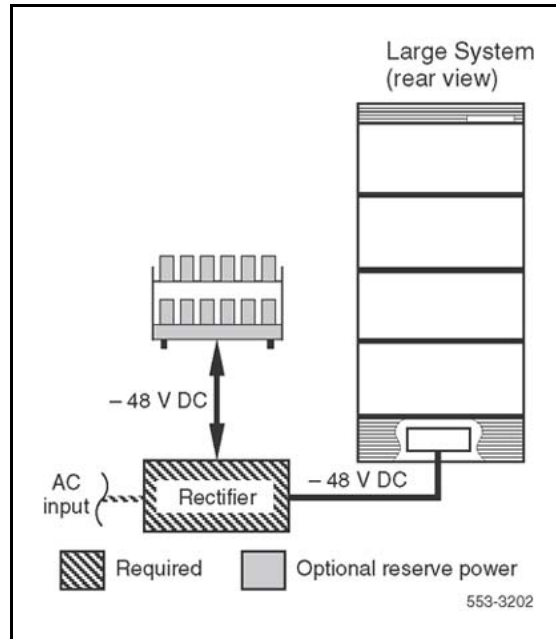

Candeo DC power system

The Candeo platform provides a simple, quick-to-deploy, and easy-to-operate power solution. Based upon modular building blocks (rectifiers, System Manager, DC distribution, and battery connection modules), the system is designed to power -48 V DC applications. The Large Candeo power system uses 50 A rectifiers and has a capacity of 1000 A; the Small Candeo (SP48300) uses 30 A rectifiers and has a capacity of 300 A. Both Large and Small Candeo systems provide "plug and walk-away" installation and setup. The platform can be reconfigured or expanded while it remains online.

Signaling Server

CS 1000M systems use a Signaling Server. The Signaling Server is an PC-based server that provides a central processor to drive H.323 and Session Initiation Protocol (SIP) signaling for IP Phones and IP Peer Networking. It provides signaling interfaces to the IP network using software components that operate on the VxWorks^a real-time operating system.

The legacy Nortel ISP1100 Signalling Server can still be used.

CS 1000 Release 5.5 introduces three new servers that can host a CS 1000 Release 5.5 Signaling Server:

- [“Nortel Common Processor Pentium Mobile server” \(page 50\)](#)
- [“International Business Machines X306m server” \(page 51\)](#)
- [“Hewlett Packard DL320-G4 server” \(page 51\)](#)

The Signaling Server has both an ELAN and TLAN network interface. The Signaling Server communicates with the Call Server through an ELAN subnet.

The Signaling Server is mounted in a 19-inch rack. The Signaling Server can be installed in a load-sharing redundant configuration for higher scalability and reliability.

The following software components operate on the Signaling Server:

- [“Terminal Proxy Server” \(page 52\)](#) (TPS)
- [“SIP/H.323 Signaling Gateways” \(page 52\)](#)
- [“Network Routing Service” \(page 53\)](#) (NRS)
- [“Element Manager” \(page 55\)](#)
- Application Server

Signaling Server software elements can coexist on one Signaling Server or reside individually on separate Signaling Servers, depending on traffic and redundancy requirements for each element. For any co-resident Signaling Server software element combination the maximum call rate supported is 10K cph.

For more information about H.323 and SIP Trunking, refer to *IP Peer Networking Installation and Commissioning (NN43001-313)*, .

Nortel Common Processor Pentium Mobile server

The Nortel Common Processor Pentium Mobile (CP PM) server is a high-performance, circuit card-based server that can be configured as a Call Server or a Signaling Server in a CS 1000 Release 5.5 system. The CP PM NTDW66 model can be configured as a Signaling Server and installed in a Universal Equipment Module (UEM) in a CS 1000M SG or CS 1000M MG system.

The Nortel CP PM Signaling Server delivers capacity improvement by providing flexible scaling from 0 to 22,000 IP Phones and a 70% increase in power for Signaling Server applications. The increased application power and capacity, coupled with the reduction in foot print and power consumption, means a lower cost of ownership.

The Nortel CP PM server has the following components:

- Intel Pentium M processor (1.4 Ghz)
- internal hard drive
- hot-pluggable Compact Flash (CF) card slot in the faceplate
- 2 GB of SDRAM
- One 1 GB/s Ethernet port
- Two 100BaseT Ethernet ports
- Two serial ports
- One USB port

For more information about installing and configuring the Nortel CP PM server as a Signaling Server, see *Signaling Server Installation and Commissioning (NN43001-312)*, .

International Business Machines X306m server

The International Business Machines (IBM) X306m 1U server is a rack-mounted, Pentium 4, PC-based, industry-standard, commercial off-the-shelf (COTS) server.

The IBM X306m 1U server has the following components:

- Intel Pentium 4 processor (3.6 GHz)
- Two 80 GB simple swap Serial ATA hard drives (1 drive configured)
- 8 GB of RAM PC4200 DDR II by means of 4 DIMM slots (2 GB configured)
- Two 1 GB/s Ethernet ports
- One DVD-COMBO (DVD/CD-RW) drive
- One serial port
- Four USB ports

For more information about installing and configuring the IBM X306m server as a Signaling Server, see *Signaling Server Installation and Commissioning (NN43001-312)*.

Hewlett Packard DL320-G4 server

The Hewlett Packard (HP) DL320-G4 1U server is a rack-mounted, Pentium 4, PC-based, industry-standard, commercial off-the-shelf (COTS) server.

The HP DL320-G4 1U server has the following components:

- Intel Pentium 4 processor (3.6 GHz)
- Two 80 GB SATA Hard drives (1 configured)
- 4 GB PC2-4200 ECC DDR2 SDRAM (2 GB configured)
- Two 10/100/1000BaseT Ethernet ports
- One CD-R/DVD ROM drive
- One serial port
- Three USB ports
- For more information about installing and configuring the HP DL320-G4 server as a Signaling Server, see *Signaling Server Installation and Commissioning (NN43001-312)*, .

Terminal Proxy Server

The Terminal Proxy Server (TPS) acts as a signaling gateway between the IP Phones and the Call Server using the UNISlim protocol. It performs the following functions:

- converts the IP Phone UNISlim messages into messages the Call Server can interpret
- allows IP Phones to access telephony features provided by the Call Server

The TPS also controls IP Phone registration.

SIP/H.323 Signaling Gateways

SIP/H.323 Signaling Gateways are software components configured on virtual loops, similar to IP Phones. They bridge existing call processing features and the IP network. They also enable access to the routing and features in the MCDN feature set.

Note 1: The SIP/H.323 Signaling Gateway must register with the Network Routing Service (NRS).

Note 2: Virtual TNs enable you to configure service data without hardwiring IP Phones to the CS 1000M system. Virtual TNs are configured in LD 97.

To support IP Peer Networking, dual Call Servers in a CS 1000M must be associated with Signaling Servers that run SIP/H.323 Signaling Gateway software. The number of Signaling Servers required depends on the capacity and level of redundancy required.

Network Routing Service

NRS for CS 1000 Release 5.5 software is offered in two versions: a SIP Redirect Server NRS and a SIP Proxy NRS.

The SIP Redirect Server NRS is hosted either co-resident with Signaling Server applications, or in a stand-alone mode on a dedicated Common Processor Pentium Mobile (CP PM) server running the VxWorks™ real-time operating system. There are no changes to the SIP Redirect Server NRS in CS 1000 Release 5.5.

The SIP Proxy NRS is hosted in a stand-alone mode on a dedicated commercial off the shelf server running the Linux™ real-time operating system. The SIP Proxy NRS is referred to as the Linux-based NRS.

The NRS application provides network-based routing, combining the following into a single application:

- **H.323 Gatekeeper** — The H.323 Gatekeeper provides central dialing plan management and routing for H.323-based endpoints and gateways.
- **SIP Redirect Server** — The SIP Redirect Server provides central dialing plan management and routing for SIP-based endpoints and gateways.
- **NRS Database** — The NRS database stores the central dialing plan in XML format for both the SIP Redirect Server and the H.323 Gatekeeper. The SIP Redirect Server and H.323 Gatekeeper both access this common endpoint and gateway database.
- **Network Connect Server (NCS)** — The NCS is used only for Virtual Office, Branch Office, and Geographic Redundancy solutions.
- **NRS Manager web interface** — The NRS provides its own web interface to configure the SIP Redirect Server, the H.323 Gatekeeper, and the NCS.

The NRS application provides routing services to both H.323 and SIP-compliant devices. The H.323 Gatekeeper can be configured to support H.323 routing services, while the SIP Redirect Server can be configured to support SIP routing services.

The H.323 Gatekeeper and the SIP Redirect Server can reside on the same Signaling Server. Examples of H.323 and SIP-compatible endpoints needing the services of the NRS are CS 1000E. The NRS also supports endpoints that do not support H.323 Registration, Admission, and Status (RAS) or SIP registration with the NRS.

Note: Systems that do not support H.323 RAS procedures and H.323 Gatekeeper procedures are referred to as non-RAS or static endpoints.

Each CS 1000E in an IP Peer network must register to the NRS. The NRS software identifies the IP addresses of PBXs based on the network-wide numbering plan. NRS registration eliminates the need for manual configuration of IP addresses and numbering plan information at every site.

SIP Proxy

Communication Server (CS) 1000 Release 5.5 adds a transaction stateful SIP Proxy to the IP Peer Network.

A SIP Proxy acts as both a server and a client. A SIP Proxy receives requests, determines where to send the requests, and acting as a client on behalf of SIP endpoints, passes requests to another server.

A SIP Proxy makes the following features and functionality, which are provided by CS 1000 Release 5.5, possible:

1. Transport Layer Security (TLS).
TLS provides the NRS with private, secure signaling, message authentication, confidentiality, and integrity through end-to-end encryption of media exchanged between two SIP endpoints.
2. Mixed transport layer protocol.
A mixed transport layer protocol enables gateways using TCP, TLS over TCP, or UDP to interoperate.
3. Network features.
By default the SIP Proxy and Redirect Server functions as a SIP Proxy. However, an endpoint can request transaction by transaction that the SIP Proxy act as a SIP Redirect Server.
A SIP Redirect Server receives requests, but does not pass the requests to another server. Instead, a SIP Redirect Server sends a response back to the SIP endpoint, indicating the IP address of the called user.
4. Post-routing SIP URI modification.
5. Transaction forking.

Element Manager

Element Manager is a software application that provides a web interface to support administration of system components, including the Signaling Server. With Element Manager, single web pages provide access to information traditionally spread throughout multiple overlays.

Element Manager provides tools to configure and maintain the following components:

- Call Servers
- Media Gateway (MG 1000E, Expander)
- MG 1000B
- Signaling Servers
- Voice Gateway Media Cards

NRS Manager

NRS Manager is a web-based management application used to configure, provision, and maintain the NRS. Key usability improvements introduced in the Linux-based NRS Manager are:

- Enhanced searching and sorting capabilities including wild cards and selectable scope of the search
- Capability to copy and move routing entries
- Simplified configuration for geographic redundancy
- Routing tests are fully integrated with endpoint and routing entry configuration
- SIP phone context mapping tools are fully integrated with endpoint and routing entry configuration
- Security infrastructure provided by the Enterprise Common Manager framework

For more information, see *Network Routing Service Installation and Commissioning (NN43001-564)*,

Software architecture

The superloop network card and IPE cards contain microprocessors that allow software changes and upgrades from the disk drive unit to be downloaded. These downloads can occur automatically, after a system reload, or manually through software program commands.

Call processing, maintenance, and administration are controlled by software programs stored either as firmware programs, as software programs resident in system memory, or as nonresident programs on disk. The information that describes system configuration and associated IPE is called office data. This data resides in the system memory and on disk.

Firmware

Firmware provides fundamental programs consisting of hard-wired logic instructions stored in Programmable Read-only Memory (PROM). Firmware programs manipulate data in the central processor and control input/output operations, error diagnostics, and recovery routines.

Software

Software programs consist of instruction sequences that control call processing, IPE, administration, and maintenance functions. Several generic software programs with optional feature packages are available.

Office data

Office data describes the characteristics of the system in terms of configuration and call-dependent information, such as features and services. Office data is arranged in blocks defining IPE, system configuration, and transient data.

Resident programs

Resident programs are always available in memory during system operation. Some resident programs are permanently programmed into the ROM portion of system memory. Other resident programs are automatically loaded into system memory at system power-up.

Resident programs include:

- Error Monitor, which continuously monitors call processing
- Initialize Program, which locates faults, rebuilds data, and releases reserve memory areas
- Overlay Loader, which locates, checks, and loads programs into the overlay area
- Overload Monitor, which monitors the volume of system messages and determines where overloads occur
- Resident Trunk Diagnostic, which monitors all trunk calls
- System Loader, which loads resident programs from the disk drive unit into system memory at power-up
- Traffic Monitor, which examines the system schedule, transfers traffic data from accumulating to holding registers, and produces reports

All software programs, including the nonresident programs listed in the following section are resident in, and accessible from, the memory on the cards listed above.

Nonresident programs

Nonresident programs are stored on data disks and loaded into the overlay area of system memory to perform specific tasks. They are removed from the overlay area when no longer required. Nonresident programs can be loaded automatically, under program control, or manually, through software commands.

Nonresident programs are manually loaded into memory through the system terminal (or maintenance telephone). A terminal can be configured as an input-only, output-only, or input and output device.

Software programs provide the system interface for maintenance, service change, and traffic measurement. Each program is independent and has its own specific set of commands and formats. These programs run concurrently with normal call processing without interfering with system traffic.

There are five main categories of nonresident programs:

- service change and print routines
- maintenance diagnostics
- traffic
- equipment data dump
- software audit

Service change and print routines

Service changes do not usually require hardware changes. Instead, the service administration programs are used to create or modify all aspects of the system from individual feature key assignments to complete system configurations. There are also programs and print routines for retrieving data from the system to check the status of office data assignments.

Maintenance diagnostics

These programs are the primary instrument for clearing system faults. Individual programs are used for automatically or manually testing the Common Equipment and IPE. The programs can be loaded into the overlay area at the request of maintenance personnel, or as part of a daily maintenance routine automatically initiated by the system at a specified time. In addition, background and signaling diagnostic routines can occupy the overlay area when it is not in use.

Traffic

All systems are equipped with traffic data accumulation programs. There is also a resident traffic print program that examines the schedules, transfers data from accumulating to holding registers in accordance with schedules, and prints the traffic data. In addition, there is a traffic program used to query and modify schedules, options, and thresholds.

Equipment data dump

After making service changes, the changes must be saved to disk in order to save them. When the equipment data dump program is run, all the office data in the read/write memory is written to the system disk. The program can be run automatically during the midnight routine or on a conditional basis (for example, a data dump would only occur if a software service change has been made). It can also be run manually through the system terminal.

The data dump program is also used to install a new generic version or issue and capture protected data store information (such as speed call lists) that may be changed by a user.

Software audit

This program monitors system operation and gives an indication of the general state of the system operation. The program is concerned mainly with the system software. When a software problem is encountered, the program attempts to clear the problem automatically.

Configuration options

Large Systems offer the following configuration options to support increased system redundancy:

- [“Fiber Remote IPE” \(page 58\)](#)
- [“Carrier Remote IPE” \(page 61\)](#)
- [“Branch Office” \(page 62\)](#)
- [“Geographic Redundancy” \(page 62\)](#)

Fiber Remote IPE

Large Systems can be configured in a distributed system to support remote subscribers, using Remote IPE modules or small cabinets. Fiber-optic links are used to connect the Remote IPE modules and small cabinets to the PBXs.

In a distributed system, subscriber connections are the same at local IPE modules as they are at Remote IPE modules or small cabinets. Furthermore, because Remote IPE equipment uses common and network equipment from the local system, subscriber functions and features are the same at local and remote sites.

Figure 19 "Large System to Remote IPE site" (page 59) illustrates the fiber-optic connection between a local system and remote system.

Figure 19
Large System to Remote IPE site

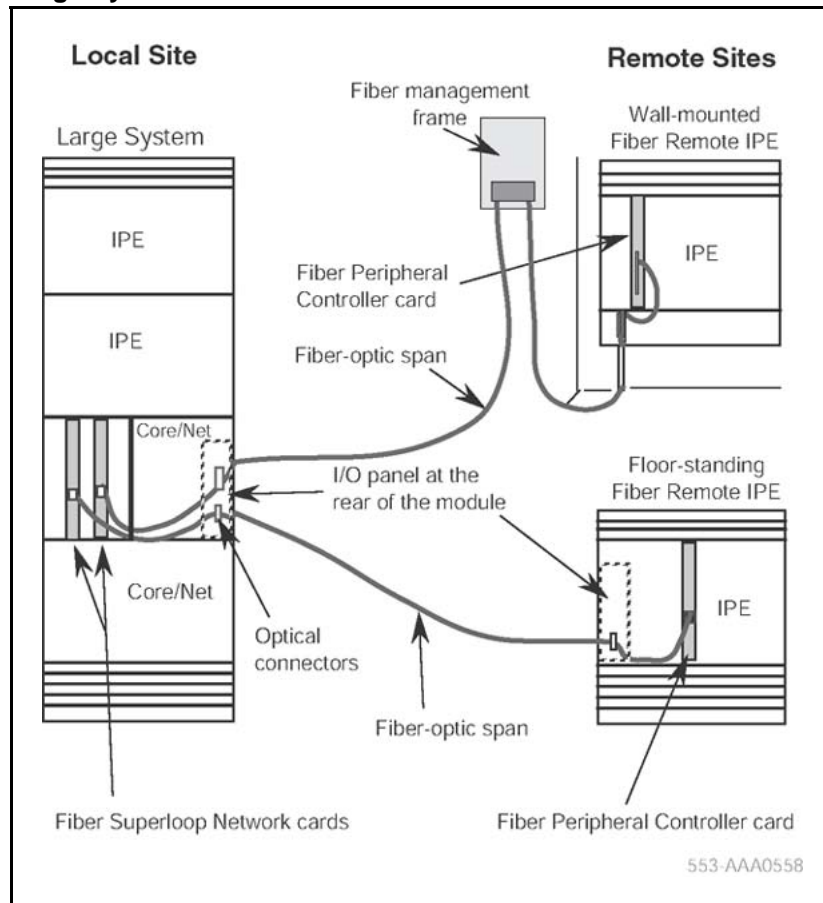

Fiber Remote Multi-IPE Interface

The Fiber Remote Multi-IPE Interface links a Large System with one or more Remote IPE sites to provide Meridian 1 Large System functionality. Since the remote IPE system uses the Common Equipment and Network Equipment of the associated local Large System, it can deliver the same features and functionality as the local system. Figure 20 "Meridian 1 Large System to Remote IPE connection over fiber-optic link" (page 60) illustrates the fiber-optic connection between the local system and remote system.

The Fiber Remote Multi-IPE Interface links the local and remote systems using a fiber-optic link over a single-mode optical fiber.

The Fiber Remote Multi-IPE Interface is available in four options which allow the same configuration of the superloop connections at the remote site as the configuration of the IPE modules at the local site:

- Single-mode fiber supporting four superloops
- Single-mode fiber supporting two superloops
- Multi-mode fiber supporting four superloops
- Multi-mode fiber supporting two superloops

Figure 20
Meridian 1 Large System to Remote IPE connection over fiber-optic link

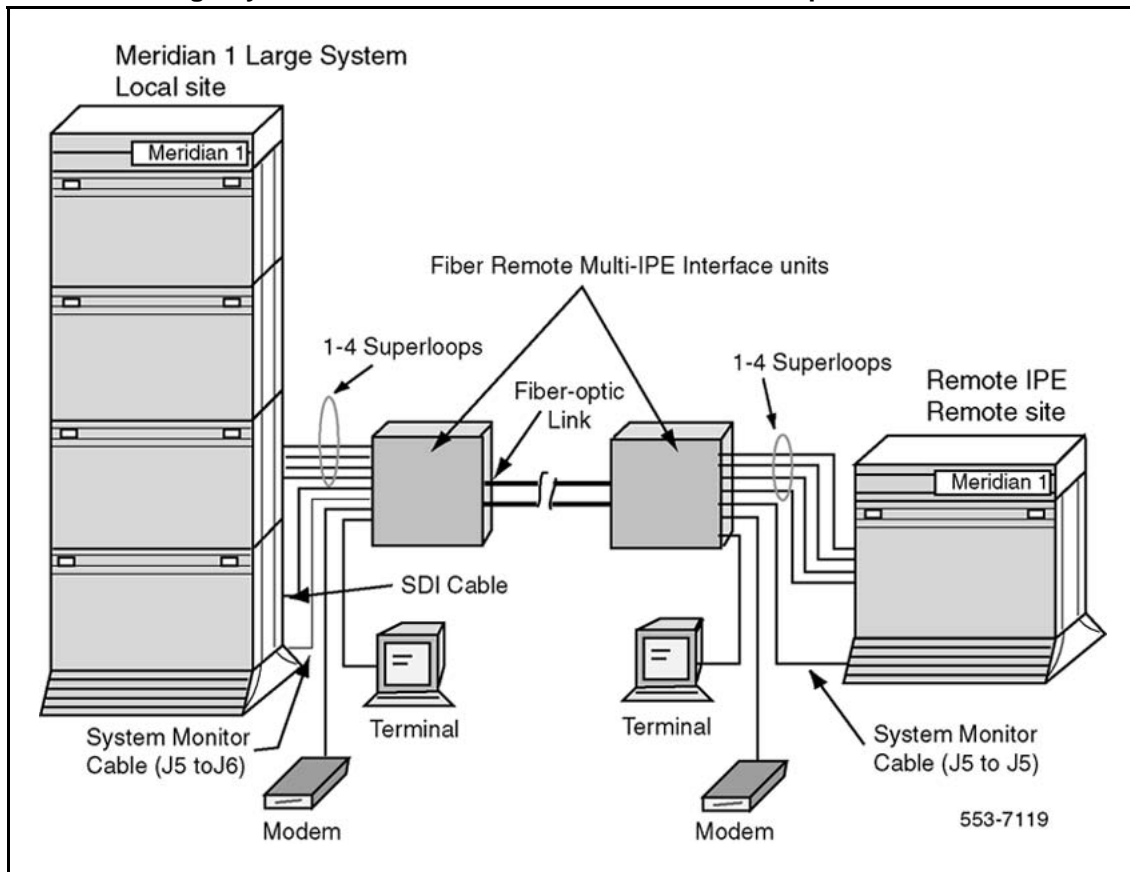

For more information on Fiber Remote IPE, see *Fiber Remote IPE Fundamentals (NN43021-554)*, . For more information on the Fiber Remote Multi-IPE Interface, see *Fiber Remote Multi-IPE Interface Fundamentals (N43021-556)*, .

Carrier Remote IPE

The Carrier Remote IPE provides functionality by installing only IPE modules and IPE cards at a distant site. The Remote IPE shares the system's Common and Network Equipment to provide the same functions and features to remote subscribers that are available to local system subscribers.

A floor-standing column or a wall-mounted cabinet Carrier Remote IPE is installed at the remote site and is connected to the Meridian 1 Large System using T1 or E1 connection. [Figure 21 "Meridian 1 Large Systemto Carrier Remote IPE links"](#) (page 61) illustrates the connection between the local system and remote system.

Figure 21
Meridian 1 Large Systemto Carrier Remote IPE links

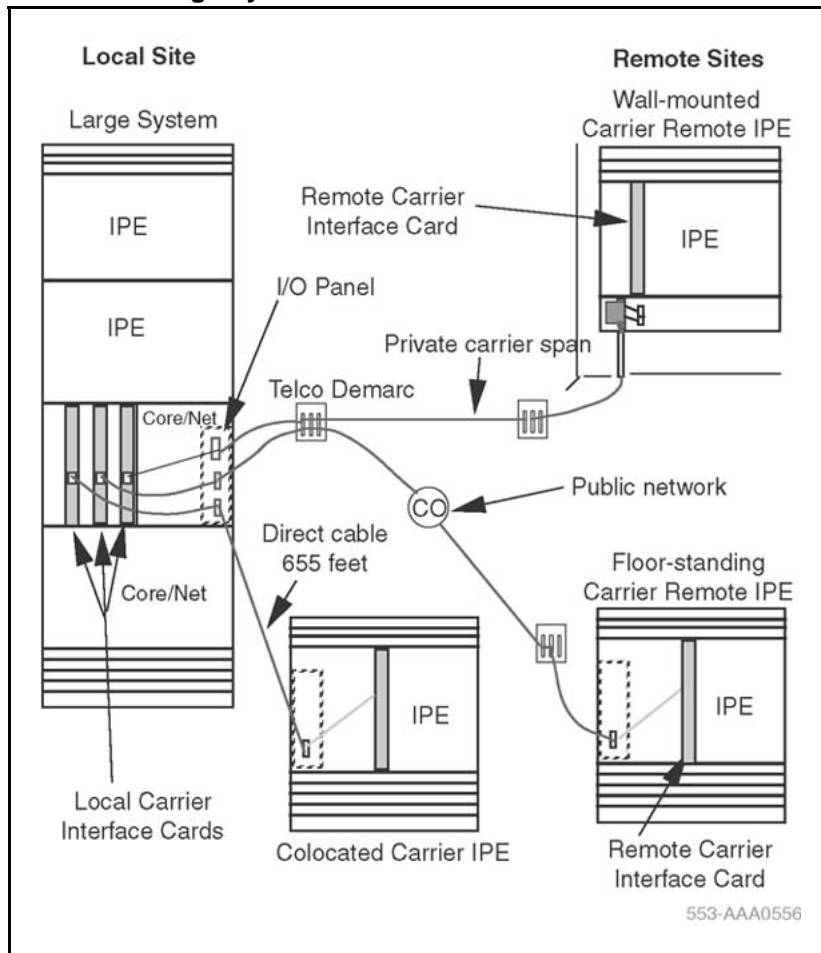

For more information on Carrier Remote IPE, see *Carrier Remote IPE Fundamentals (NN43021-555)*, .

Branch Office

The Branch Office feature extends system features from a main office to one or more branch offices.

A branch office is an MG 1000B Core connected to an IP PBX at the main office over an enterprise IP network or over a WAN. This configuration enables a secondary location to centralize the call processing of its IP-based communications network. The Call Server at the main office provides the call processing for the IP Phones in both the main office and branch offices. The MG 1000B Core provides call processing functionality to local digital telephones and analog devices. The MG 1000B Core also provides digital and analog trunk access to the local Public Switched Telephone Network (PSTN).

The branch office connects to the main office over Virtual Trunks on an enterprise IP network or a WAN. The main office transmits and controls IP Phone calls and IP network connections. If the main office fails to function, or if there is a network outage, the MG 1000B Small System Controller (SSC) provides service to the telephones located in the branch office. This enables the IP Phones to survive the outage between the branch office and the main office.

A branch office can be created as a new hardware configuration, or by converting an existing Small System to a branch office. The functionality is the same in both configurations.

For more information on the Branch Office feature, see *Branch Office Installation and Commissioning (NN43001-314)*, .

Geographic Redundancy

Geographic Redundancy enables a customer to duplicate the entire redundant processing core of a CS 1000M SGo or CS 1000M MGsystem at a remote location, at any distance, over the customer WAN. The duplicate core can then take over processing if the primary system fails for any reason. Geographic Redundancy also offers automatic database replication between main and standby systems to promote a smooth transition. When this configuration is implemented, the customer enhances the disaster recovery capability of the network and further secures ultra-high reliability.

Note: Geographic Redundancy capabilities only apply to IP elements, for example, to IP Phones and Media Gateways. Geographic Redundancy does not apply to TDM elements.

For more information on the Geographic Redundancy feature, see *System Redundancy Fundamentals (NN43001-507)*, .

List of terms

AC	Alternating Current
analog	A process that models information in the form of a continuously varying parameter such as current, voltage, or phase.
analog signal	A signal that varies in a continuous manner such as voice or music. An analog signal can be contrasted with a digital signal, which represents only discrete states. The signal emitted by a data telephone has both analog and discrete characteristics.
architecture	The interrelationship between the parts of a system; the framework of a system.
backplane	A printed circuit board that extends across the width of the card cage and connects to the circuit card connectors.
battery backup	System power furnished by standby batteries that are charged by a charger. If commercial power fails, the batteries maintain service for a limited period of time, determined by the size of the batteries and the traffic on the system.
capacity	The information-carrying ability of a telecommunications facility, group, network, or system measured in bits per second (bps).
card cage	A frame for holding circuit cards in a module; also called a card chassis.

CBT
Core Bus Terminator

CE
Common Equipment

Central Office (CO)
The site where a telephone company terminates customer lines and houses the switching equipment that interconnects those lines.

central processing unit (CPU)
The main portion of a computer that contains the primary storage, arithmetic and logic units, and the control unit (may also mean a mainframe computer).

circuit cards
Cards which carry the electronics for particular functions (such as memory and switching functions). Most cards are housed in the card cage in a module and connect to the backplane. Some cards must be installed in dedicated slots in a card cage. (Also called circuit packs or boards.)

CNI
Core-to-Network Interface

CO
See Central Office.

Common Equipment (CE)
A hardware subsystem that houses one or more central processing units (CPUs), memory cards, disk drive units, and service cards.

configuration
A group of machines (hardware) that are interconnected and are programmed to operate as a system.

CP
Call Processor

cPCI®
Peripheral Component Interconnect. PCI provides a high-speed data path between the CPU and peripheral devices (video, disk, network, etc.).

cPCI Transition card

Peripheral Component Interconnect Transition Card. Connects the Core module cards to the 3PE cards in the Network modules.

CP PIV®

The successor to the Pentium II from Intel. Pentium IV refers to the Pentium IV CPU chip.

CPU

Central Processing Unit

DC

Direct Current

diagnostic programs

Software routines used to test equipment and identify faulty components

digital signal

A signal made up of discrete, noncontinuous pulses whose information is contained in the duration, periods, and/or amplitude

DTR

Digitone Receiver

electromagnetic interference (EMI)

Unwanted electromagnetic static coupling, such as a ham radio signal being heard on a television, or causing static noise interference.

firmware

A set of instruction sequences stored permanently in hardware (ROM).

input/output (I/O)

Exchange between a machine and end-user equipment.

IODU/C

Input/Output Disk Unit with CD-ROM

IPB

Inter-Processor Bus

IPE

Intelligent Peripheral Equipment

ISDN

Integrated Services Digital Network

line

A communication channel or circuit; an electrical path.

loop

A bidirectional path between network equipment and peripheral equipment.

module power supplies

Individual power units that generate the different DC voltages required by the cards installed in each module.

Network Equipment

A hardware subsystem that provides digital multiplexed switching for voice, data, and signaling paths.

office data

Office data represents system configuration data, peripheral equipment data, and transient data (temporary) used for call processing.

PCM

Pulse Code Modulation.

pedestal

The bottom element in a column. Each pedestal houses a blower unit, an air filter, the PDU (which contains the column circuit breakers), and the system monitor.

power distribution unit (PDU)

Input power for CS 1000M Large System and Meridian 1 Large System are brought into the pedestal to the PDU. The PDU distributes input power to the column.

Pulse Code Modulation (PCM)

A modulation technique where the signal is converted from an analog to a digital format by sampling the signal at periodic intervals and digitizing the amplitude into a finite number of discrete levels

random-access memory (RAM)

A storage system or computer memory accessible by the user for either storing or retrieving information. RAM is volatile memory.

read-only memory (ROM)

Storage system or computer memory that is "burned into" the microprocessor chip and can be read, but not written to or modified. ROM is nonvolatile memory.

redundancy

The duplication of software, or hardware, or both (such as redundant CPUs) used as a standby in case one fails.

SDI

Serial Data Interface. A family of cards equipped with SDI ports provide the I/O interface for the CS 1000M Large System and Meridian 1 Large System.

software

A set of programmed instruction sequences stored either as resident programs in system memory or as nonresident programs stored on disk and loaded into memory when needed.

software generic

A term used to identify the system software. Each software generic has a series of releases, such as Release 25.

system monitor

A microprocessor-based circuit card that controls and monitors the status of cooling equipment and power-related hardware and functions.

system utility card

Provides an interface between the security device and the computer.

TDS

Tone and Digit Switch

Time Compression Multiplexing (TCM)

The combination of two or more information channels into a single transmission channel by assigning each information channel an exclusive periodic transmission time interval.

TN

Terminal Number

top cap

A top cap is mounted on the top module of each column. It provides airflow exits, EMI/RFI shielding, I/O cable entry and exit, and overhead cable-rack mounting. The top cap covers thermal sensor assemblies for the column.

trunk

A single circuit between two points, both of which are switching centers or individual distribution points.

universal equipment module (UEM)

A modular, self-contained hardware cabinet that houses a card cage, power supply, backplane, circuit cards, and other basic equipment. When equipped, the UEM becomes a specific type of module, such as a CPU module or Network module.

UPS

Universal Power Supply

V AC

Voltage Alternating Current

V DC

Voltage Direct Current

Nortel Communication Server 1000

Communication Server 1000M and Meridian 1 Large System Overview

Copyright © 2003-2008 Nortel Networks
All Rights Reserved.

Release: 5.5
Publication: NN43021-110
Document status: Standard
Document revision: 02.05
Document release date: 30 September 2008

To provide feedback or to report a problem in this document, go to www.nortel.com/documentfeedback.

www.nortel.com
Sourced in Canada

LEGAL NOTICE

While the information in this document is believed to be accurate and reliable, except as otherwise expressly agreed to in writing NORTEL PROVIDES THIS DOCUMENT "AS IS" WITHOUT WARRANTY OR CONDITION OF ANY KIND, EITHER EXPRESS OR IMPLIED. The information and/or products described in this document are subject to change without notice.

Nortel, Nortel (Logo), the Globemark, SL-1, Meridian 1, and Succession are trademarks of Nortel Networks.

All other trademarks are the property of their respective owners.

