

*Mounted Warrior Soldier System Cordless Communications*

# Cordless Communications System (CCS)

## USER OVERVIEW

Mounted Warrior

## Cordless Communications System (CCS)

- Add-on to existing VIS (Vehicle Intercom Set)
- User stays connected to Intercom/Radio without being physically connected to vehicle by wire or cable
- Retains all features of existing VIS equipment
- User may move about vehicle un-tethered
- User may completely dismount vehicle
- Dismounted user can talk over Intercom/Radio up to 250 meters away from vehicle.
- Two-way radio feature for multiple dismounted users.

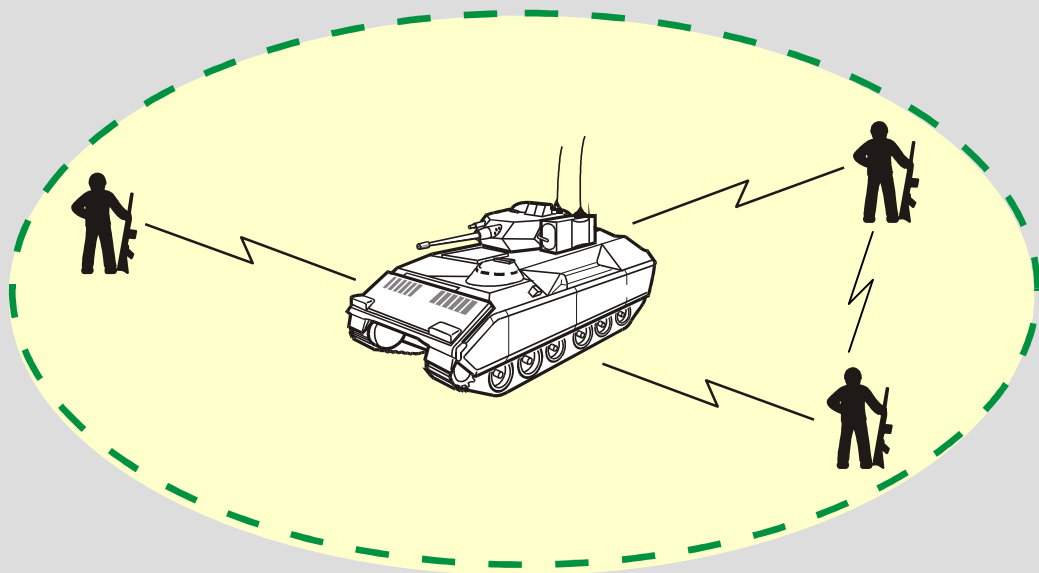

# Universal Adapter Interface (UAI)

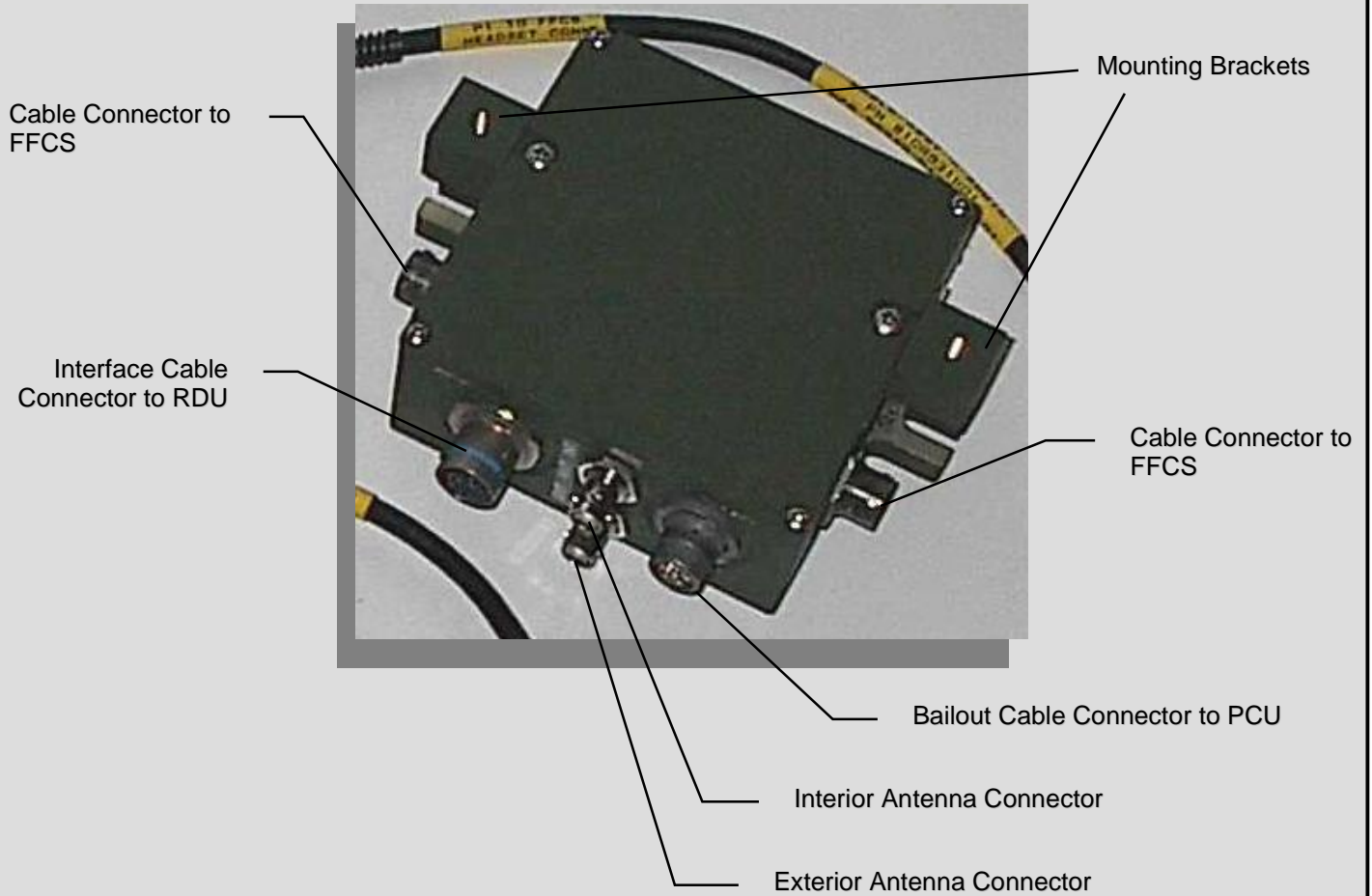

# Remote Display Unit (RDU)



Interface Cable  
Connector (to UAI)

Display

Keypad

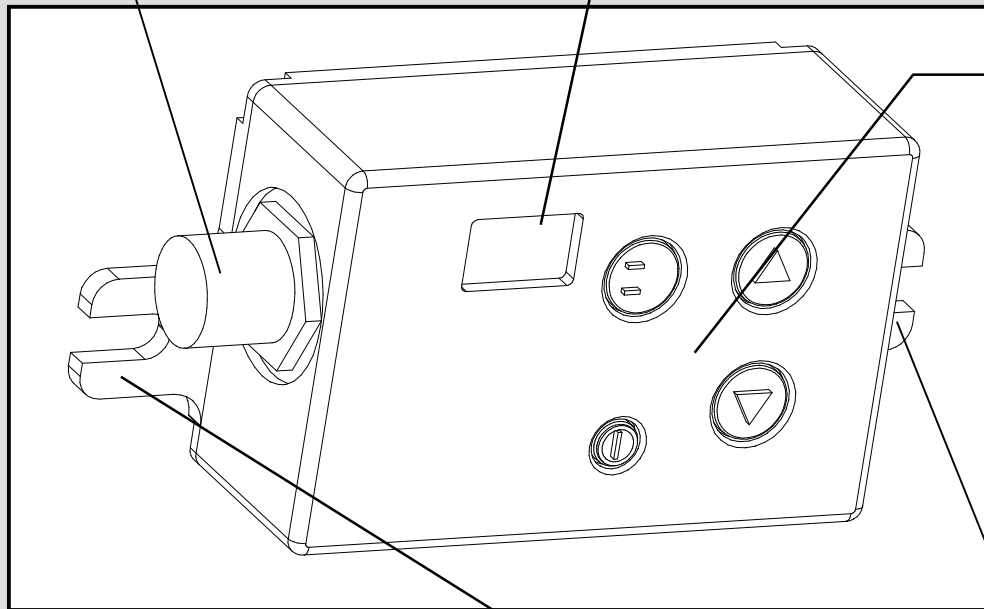

Mounting Brackets

# Personal Communications Unit (PCU)



Fully Assembled



Disassembled

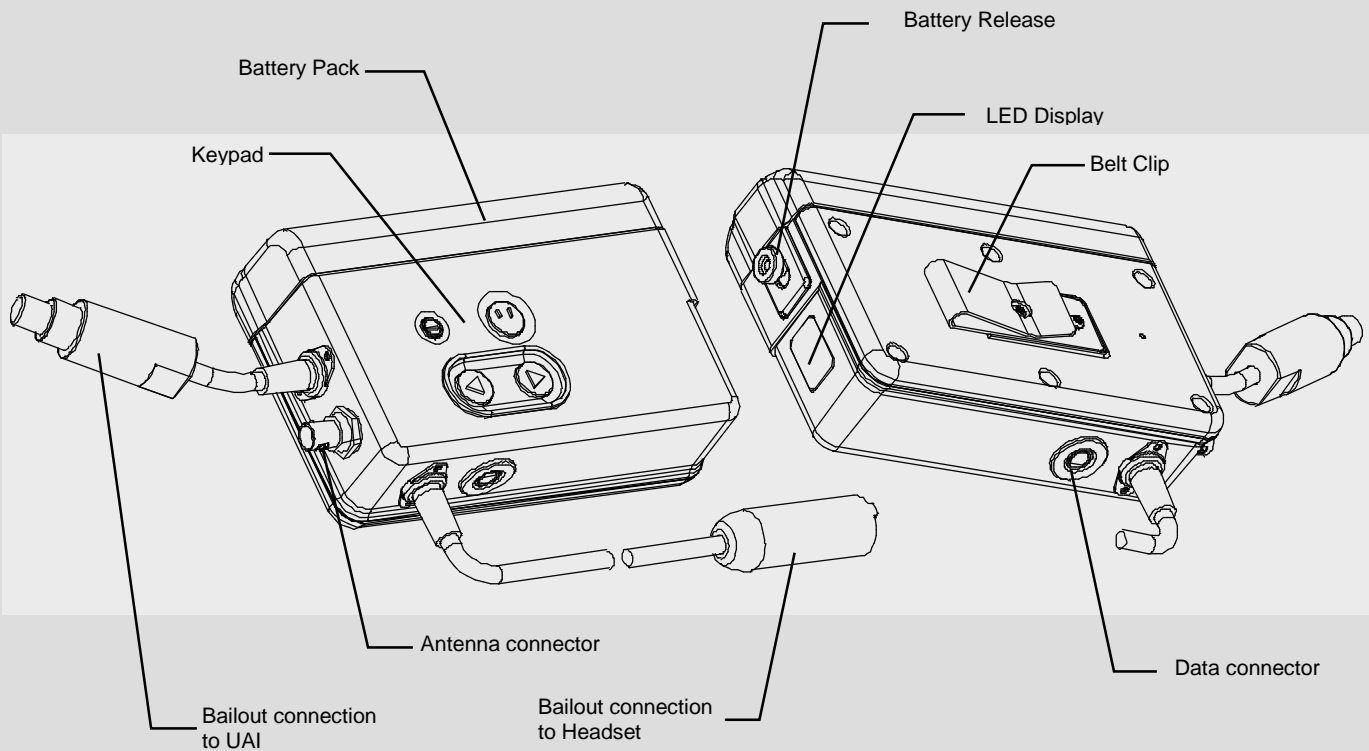

# — CCS Wiring Diagram\* —

\* for reference only / connector locations approximate

## GUNNER

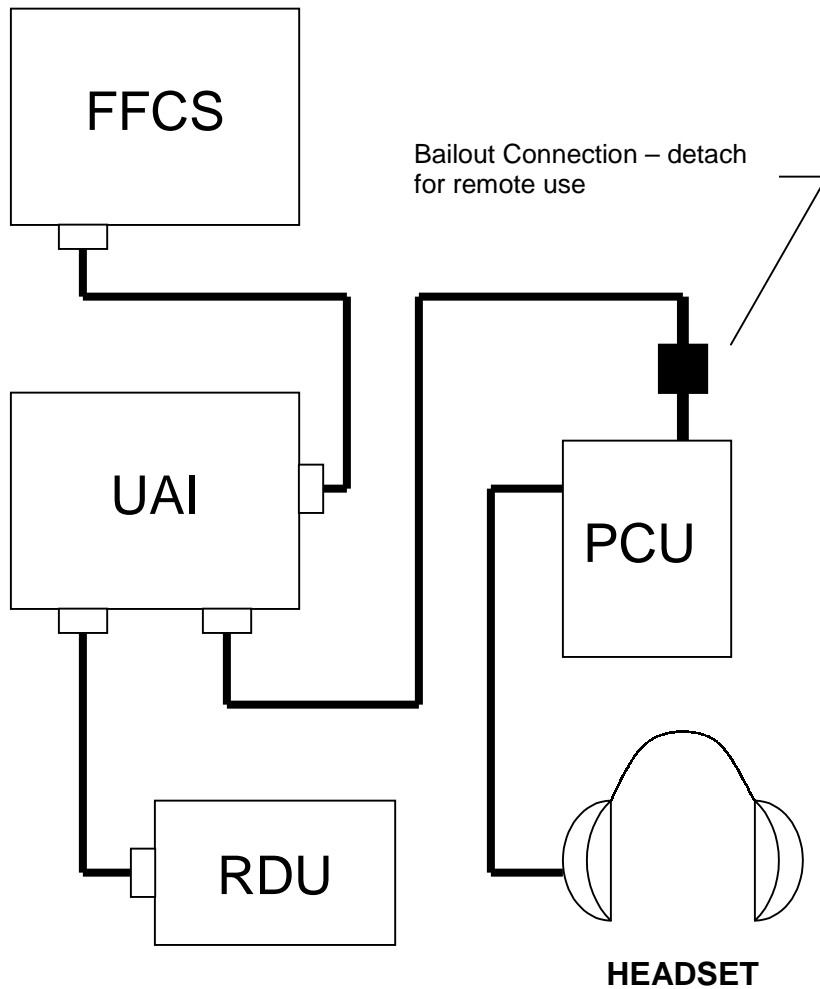

## COMMANDER / DRIVER / SOLDIER

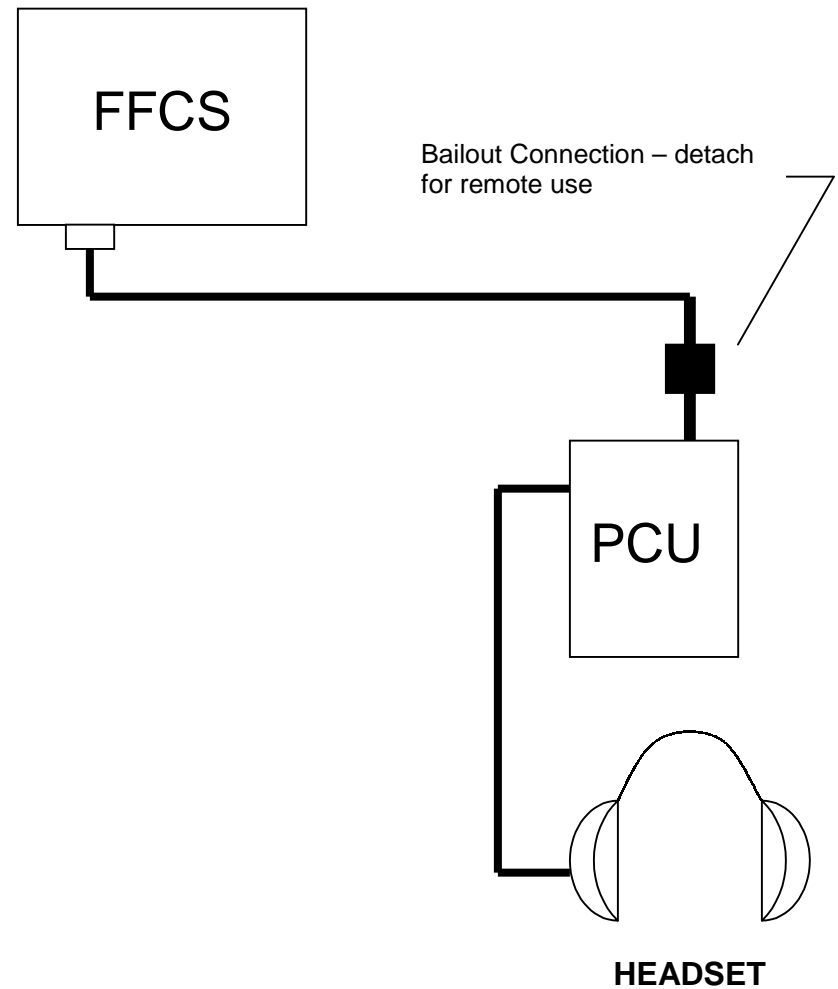

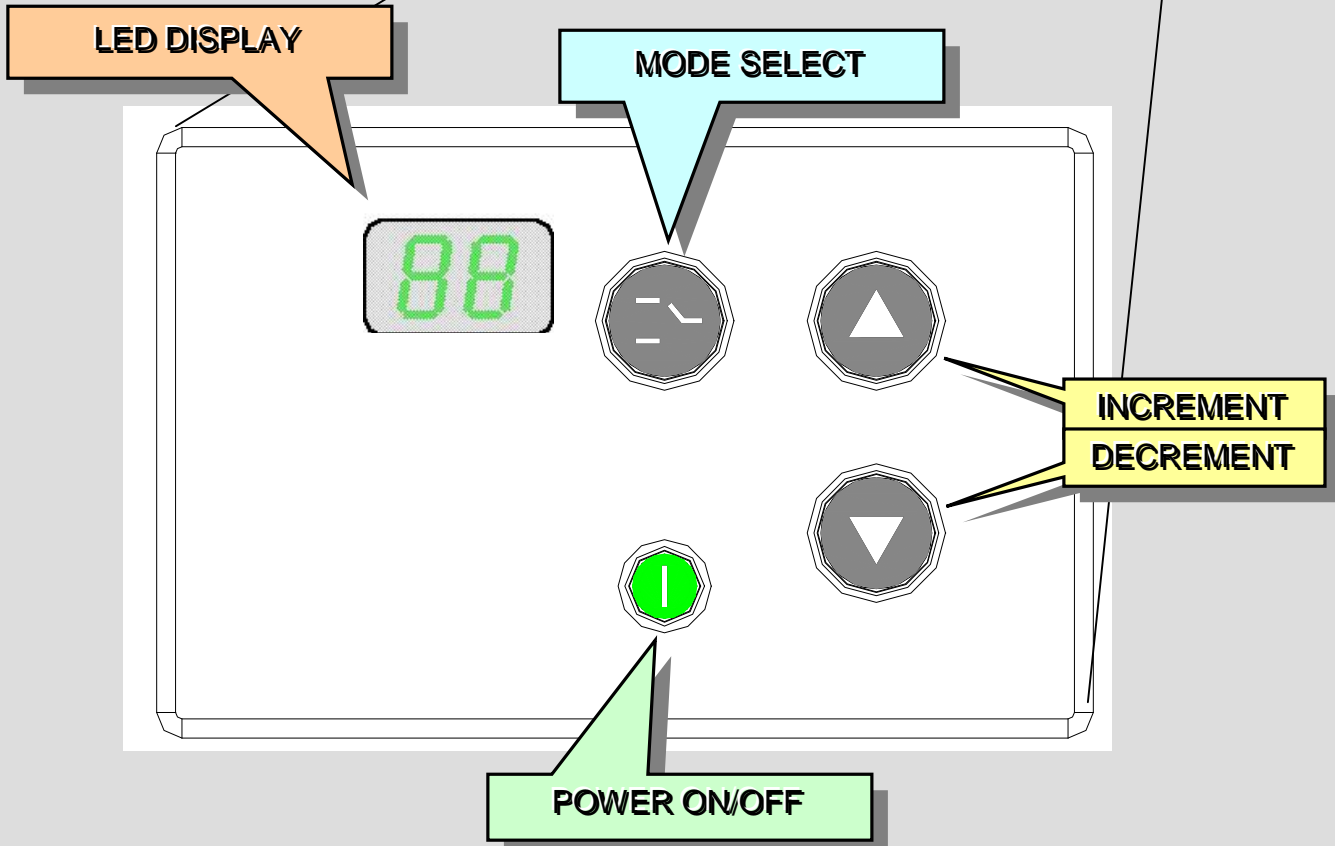

# RDU Keypad & Display

*RDU Display automatically goes blank after 5 seconds if no buttons are pressed. Press MODE SELECT button to restore display.*



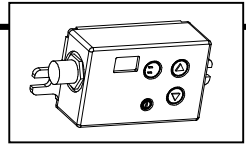



## RDU MODES







Press  to scroll through modes.

### 1. BIT (Built-In Test)





Runs self-test and displays result. Will see ; press  OR  to run self-test.

Automatically displays  if passed, OR  THRU  if failed.  
NOTE: When powering-on, RDU automatically runs BIT & displays result.







### 2. CHANNEL

Displays current channel:  THRU . Press  OR  to change channel.





### 3. VOLUME

Displays current volume:  (softest) THRU  (loudest).  
Press  OR  to increase/decrease volume.

### 4. OPERATING MODE

Displays current UAI operating mode:  (Local)\* OR  (Broadcast)  
OR  (Group) OR  (Listening Silence). Press  OR  to change operating mode. \*Default at power-up is Local mode

### 5. AUDIO/DATA

Displays current setting:  (audio) OR  (data). Press  OR  to toggle setting.



## — PCU Display\* —

*Display automatically goes blank after 5 seconds if no buttons are pressed. Press MODE SELECT button to restore display.*

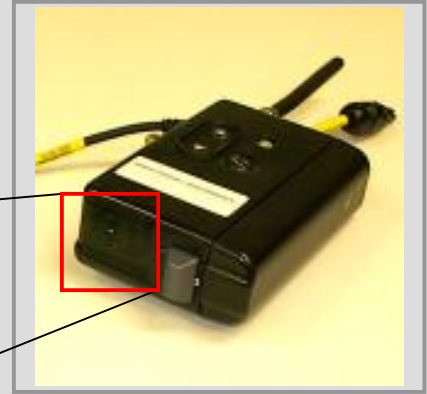
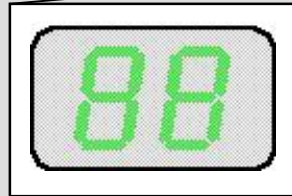

\*Display shuts off when PCU is connected to bailout cable

## — PCU Antenna —

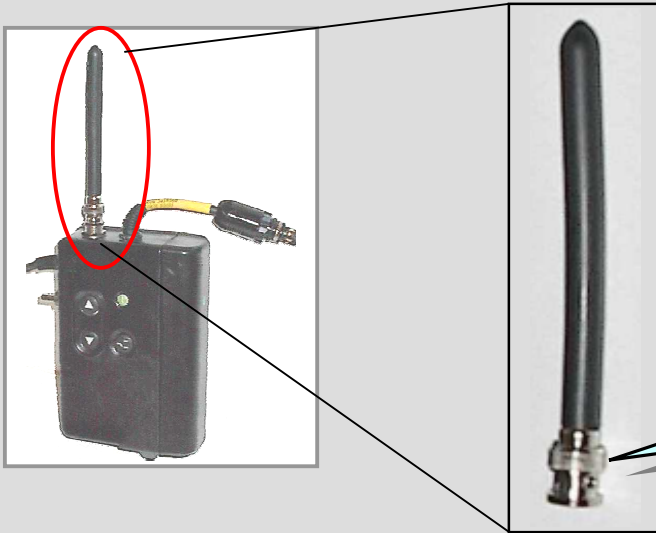

**CONNECTOR (BNC Type)**

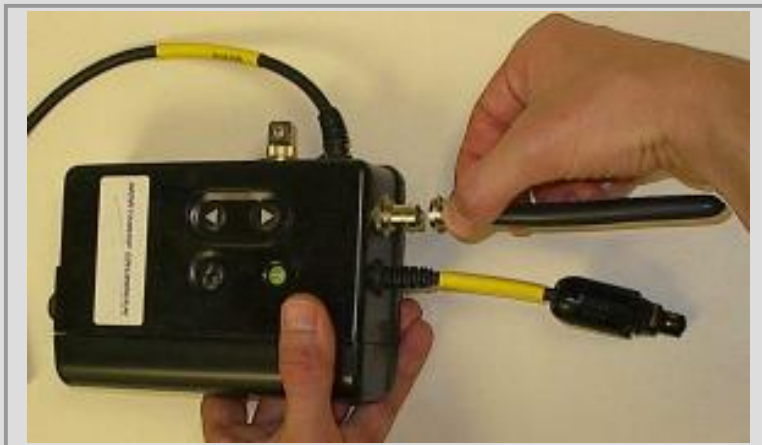

**To remove**, twist connector counter-clockwise and pull off.

**To attach**, push in and twist connector clockwise until locked.

# — PCU Keypad —

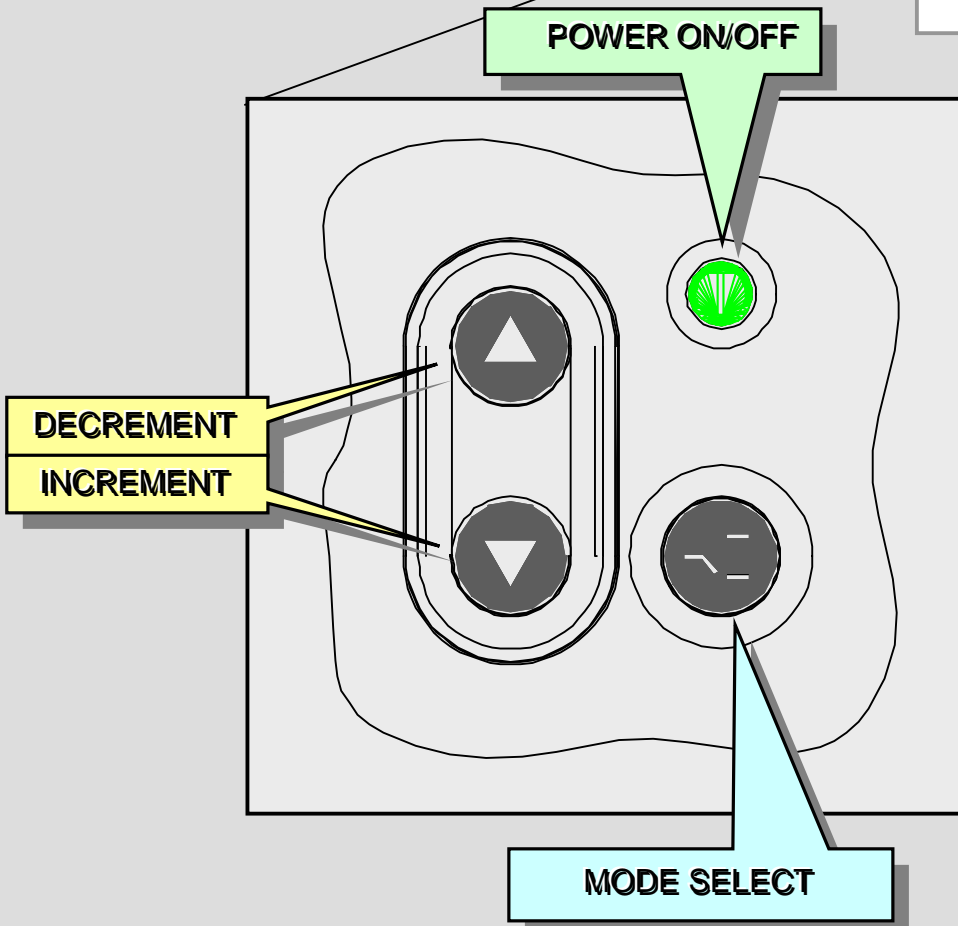

**NOTE: PCU Display automatically goes blank after 5 seconds if no buttons are pressed. Press MODE SELECT button to restore display.**



## — PCU MODES —

---





Press  to scroll through modes.

### 1. BIT (Built-In Test)

Runs self-test and displays result. Will see ; press  OR  to run self-test.



Automatically displays  if passed, OR  THRU  if failed.  
NOTE: When powering-on, PCU automatically runs BIT & displays result.

### 2. CHANNEL





Displays current channel:  THRU . Press  OR  to change channel.

### 3. VOLUME

Displays current volume:  (softest) THRU  (loudest).



Press  OR  to increase/decrease volume.

### 4. AUDIO/DATA

Displays current setting:  (audio) OR  (data). Press  OR  to toggle setting.

### 5. BATTERY STATUS

Displays current battery charge level:

 (>10% charge remaining) THRU  (>90% charge remaining). NOTE: If **b0** is seen, battery has less than 10% charge remaining and PCU will automatically shut off after 1 minute of further use. If **b\_** or blinking **F1** is seen, PCU is still attempting to sense charge level; may take up to 3 minutes when PCU is first powered-on.

## PCU Battery Pack

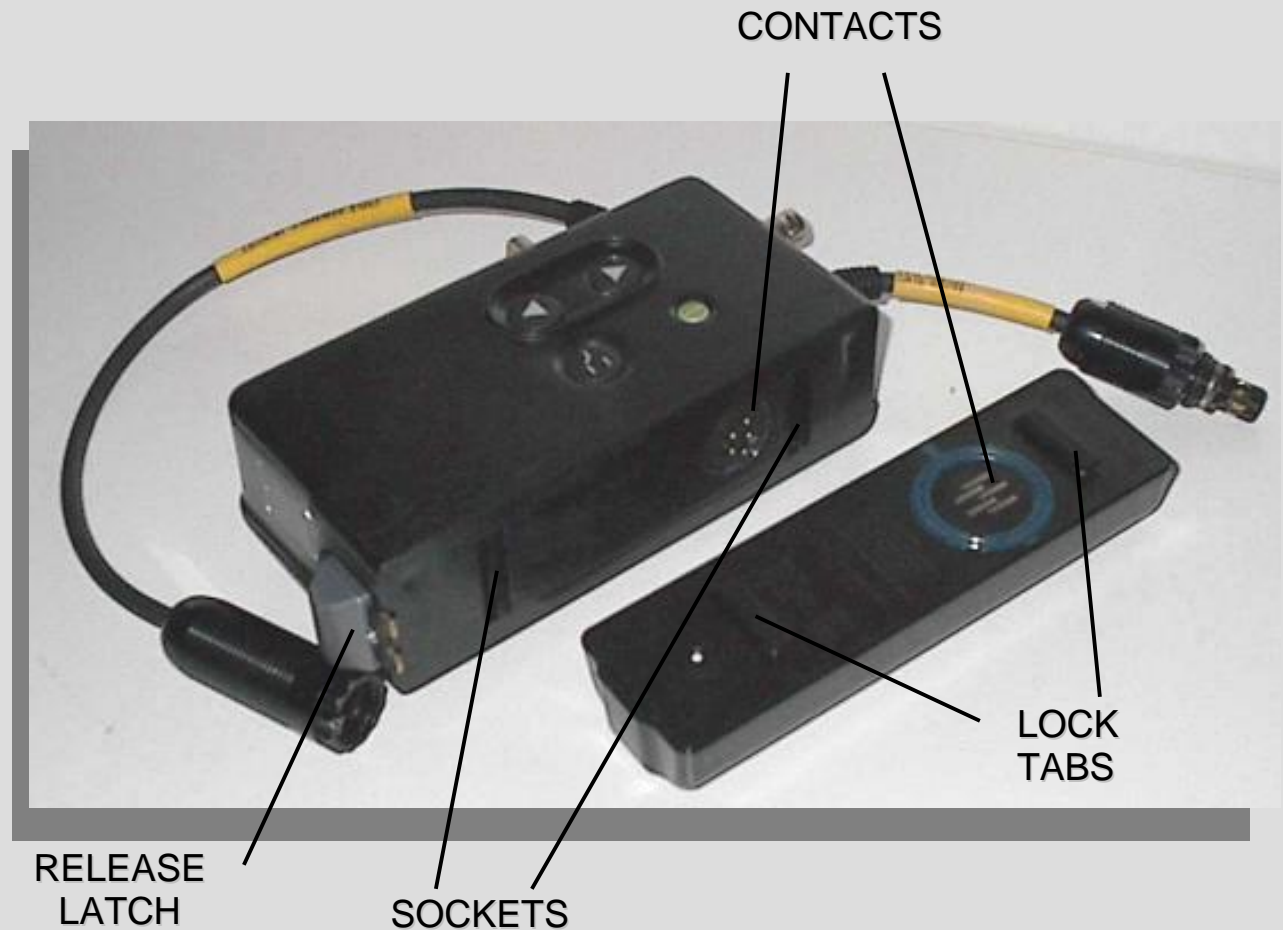

- Fully-charged battery provides at least 4 hrs of remote use
- Battery does not use charge while PCU is connected to crew station
- Audible alarm is heard in headset when charge drops below 20%



AVOID SHORTING BATTERY CONTACTS. KEEP UNUSED BATTERIES CLEAR OF METAL OBJECTS AND SURFACES.

## — Battery Removal / Installation —

### *TO REMOVE BATTERY:*

1. Power-off PCU.
2. Slide latch away from battery and hold in position.
3. Apply slight force to eject battery in direction shown.

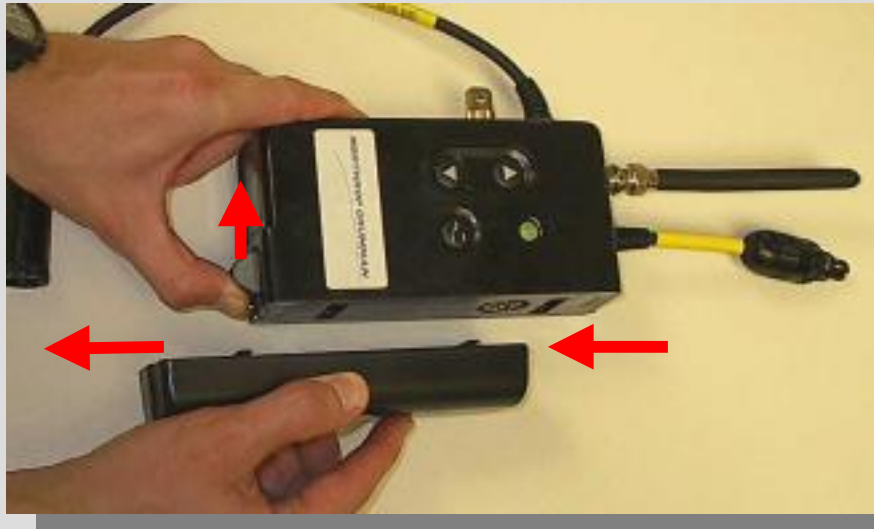

### *TO INSTALL BATTERY:*

1. Ensure battery contacts/ tabs/ sockets are aligned with PCU.
2. Insert lock tabs into sockets and press-in until battery pack is flush with PCU.
3. Apply slight force in direction shown until "click" is heard, indicating battery is locked into place.

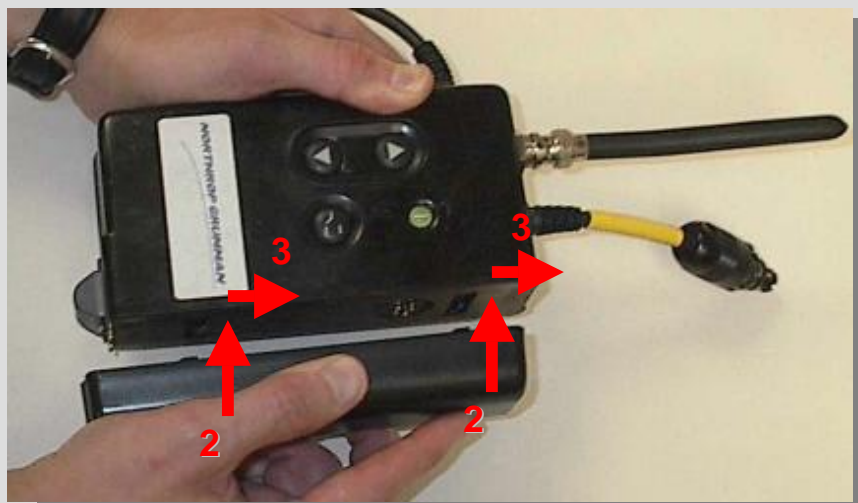

# — PCU Setup

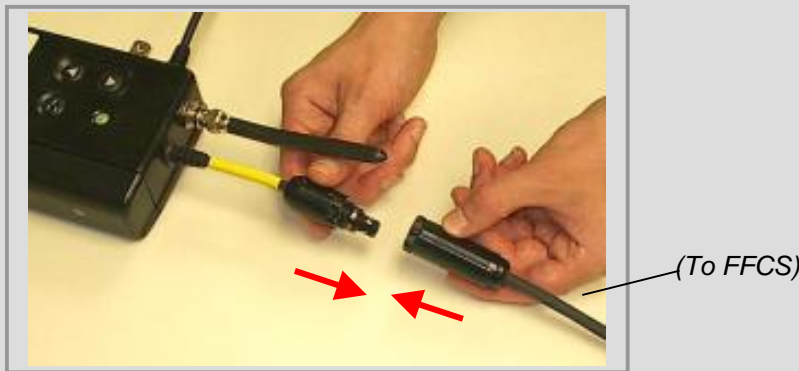
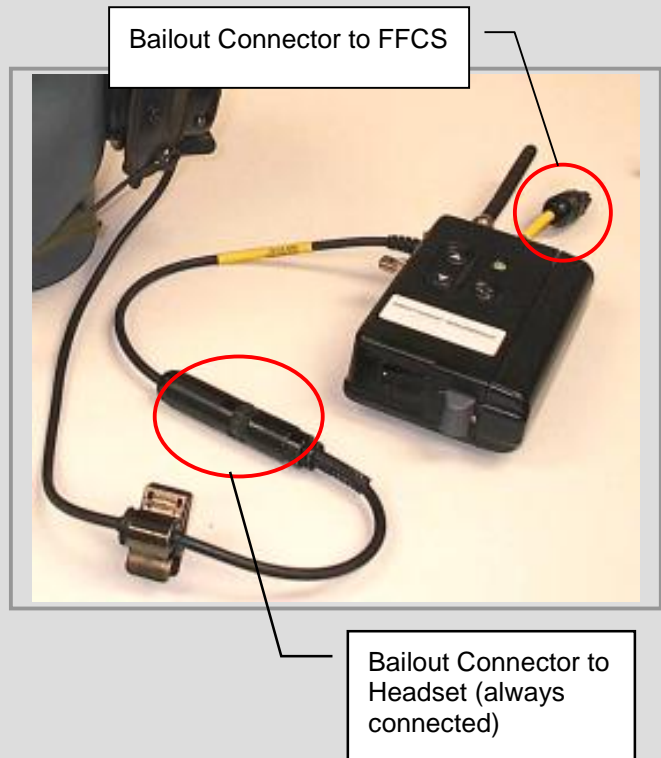

**Connect to FFCS for Onboard / Wired Use**

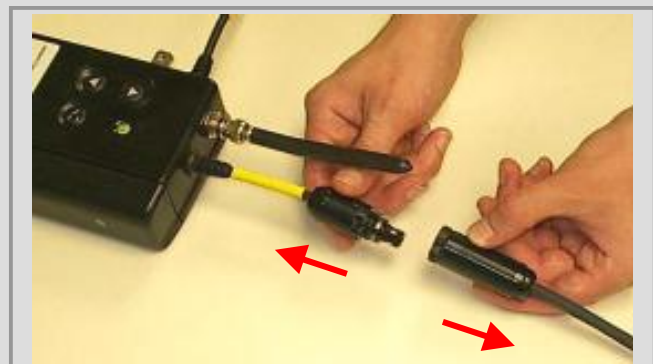

**Disconnect for Remote Use**

## — Headset Usage —

### *ON-BOARD (Connected to FFCS)*

Headset PTT switch operates per selected FFCS Intercom setting (PTT / LIVE / VOX etc.)

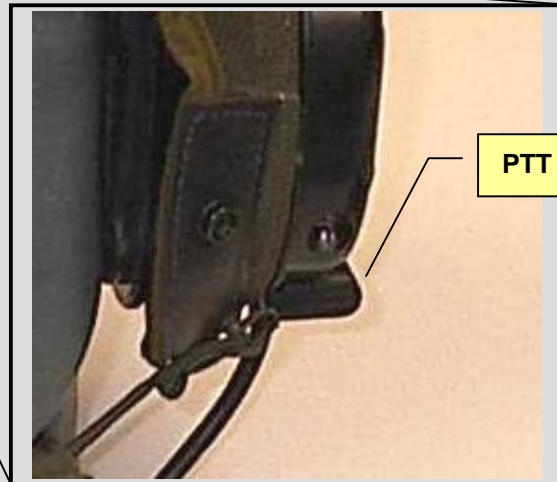

### *REMOTE (Dis connected from FFCS)*

Headset PTT Switch operates as follows:

1. Rear position: Talk (VOX) / Listen.
2. Middle position: Listen only.
3. Forward position (momentary): Talk over radio.

### **NOTE**

**All remote PCU talk is voice-activated (VOX) by default. To bypass VOX while operating remotely:**

- (1) Ensure vehicle FFCS “WORK” switch is set to “INTERCOM.”**
- (2) Hold headset PTT switch in forward (momentary) position to talk.**

# Basic Operation

**CONFIGURE FFCS\***

COMMANDER ONLY:

**POWER ON RDU**

1. Passes BIT
2. Set Channel
3. Set Volume
4. Select Operating Mode
5. Ensure Audio (AU) is selected

ALL CREW:

**DISCONNECT PCU FROM BAILOUT CABLE**

**POWER ON PCU**

1. Passes BIT
2. Set Channel
3. Set Volume
4. Ensure Audio (AU) is selected
5. Run Self-Test to confirm settings

*REMOTE / OFFBOARD USE*

**LEAVE BAILOUT CABLE DETACHED**

**\*RADIO ACCESS WHILE REMOTE IS DETERMINED BY SETTINGS OF FFCS CONNECTED TO UAI**

*WIRED / ON-BOARD USE*

**RE-ATTACH BAILOUT CABLE**



# — Autonomous Remote Use —

*2 or more remote PCUs are used as two-way radio network when set to unique channel.*

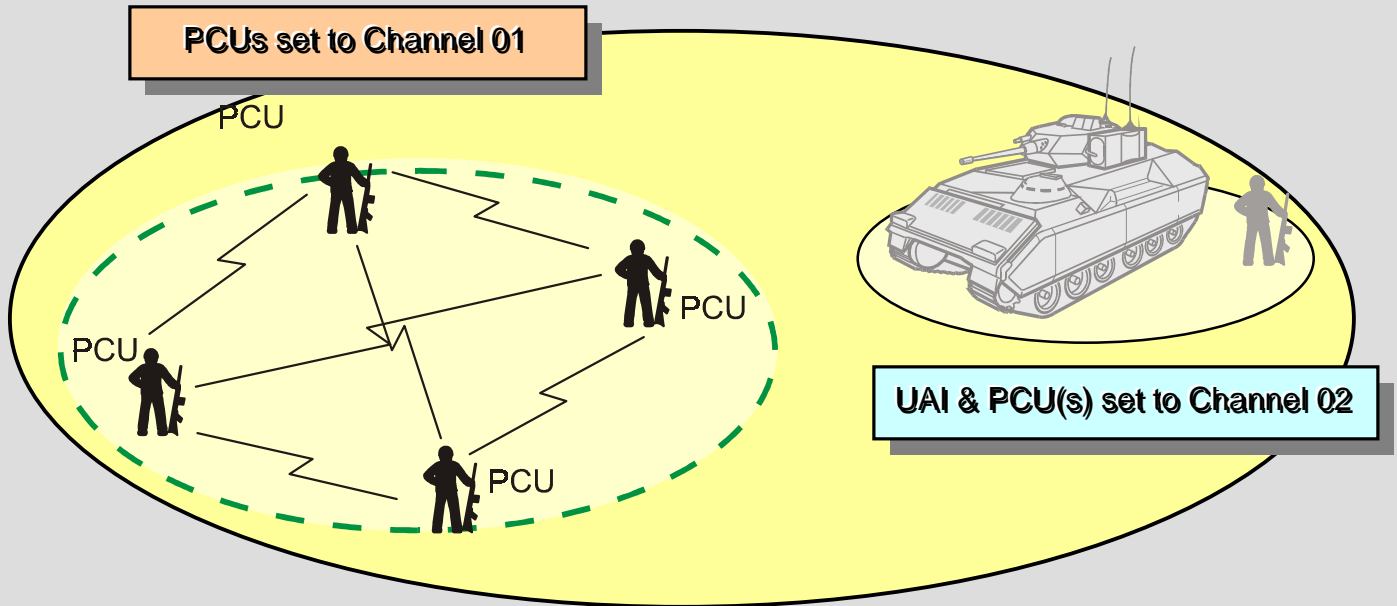

- Even if autonomous PCUs are in range of another vehicle, network is not compromised unless vehicle UAI is on same channel.
- Any PCU within range can enter the autonomous network by switching to the corresponding channel.
- Max range for Autonomous Communication = 250m (LOS)

## Local Operating Mode

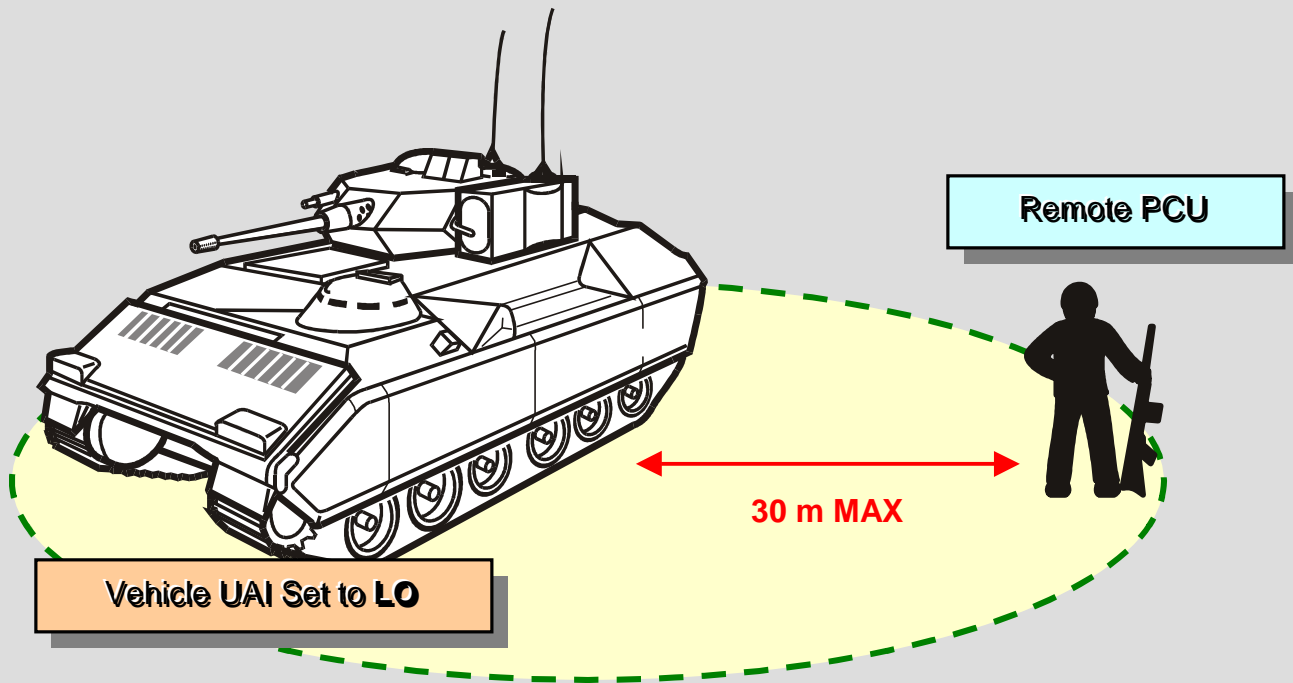

- Lowest transmitting power emitted by vehicle
- Allows onboard personnel to use VIC-3 while disconnected from bailout cable
- Not intended for off-board remote use
- Maximum Range = 30 meters (LOS)

## Broadcast Operating Mode

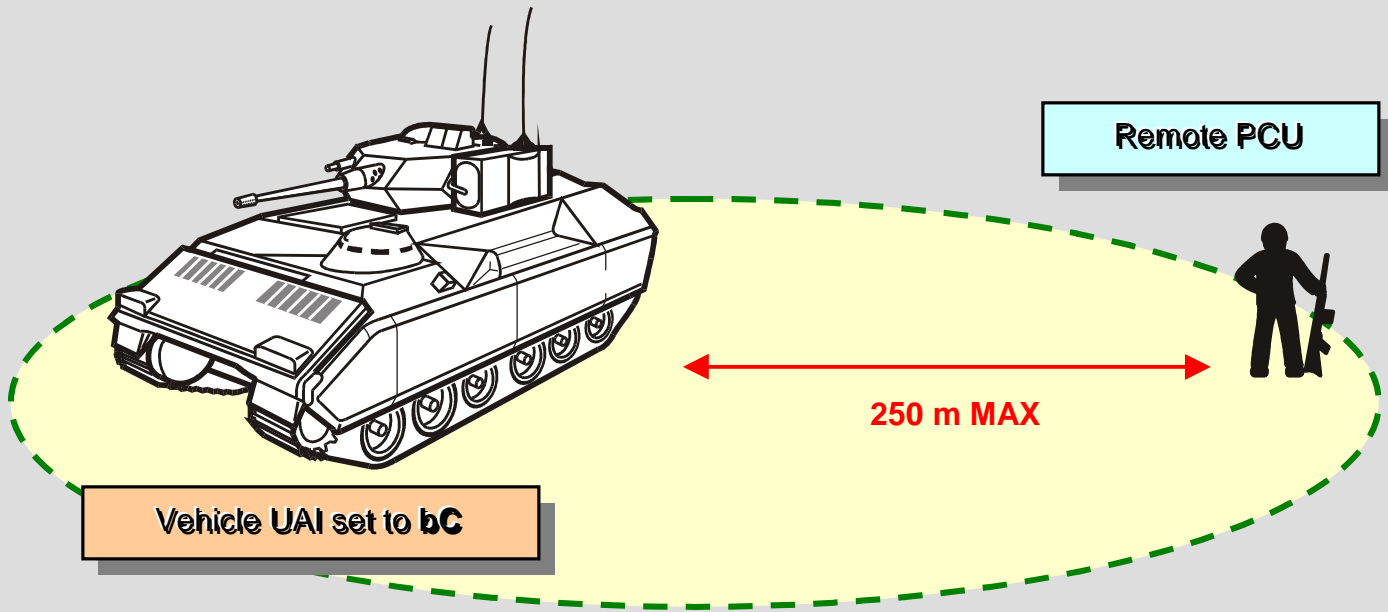

- Highest transmitting power emitted by vehicle
- Used for communicating with off-board remote users
- Maximum Range = 250 meters (LOS)

## Group Operating Mode

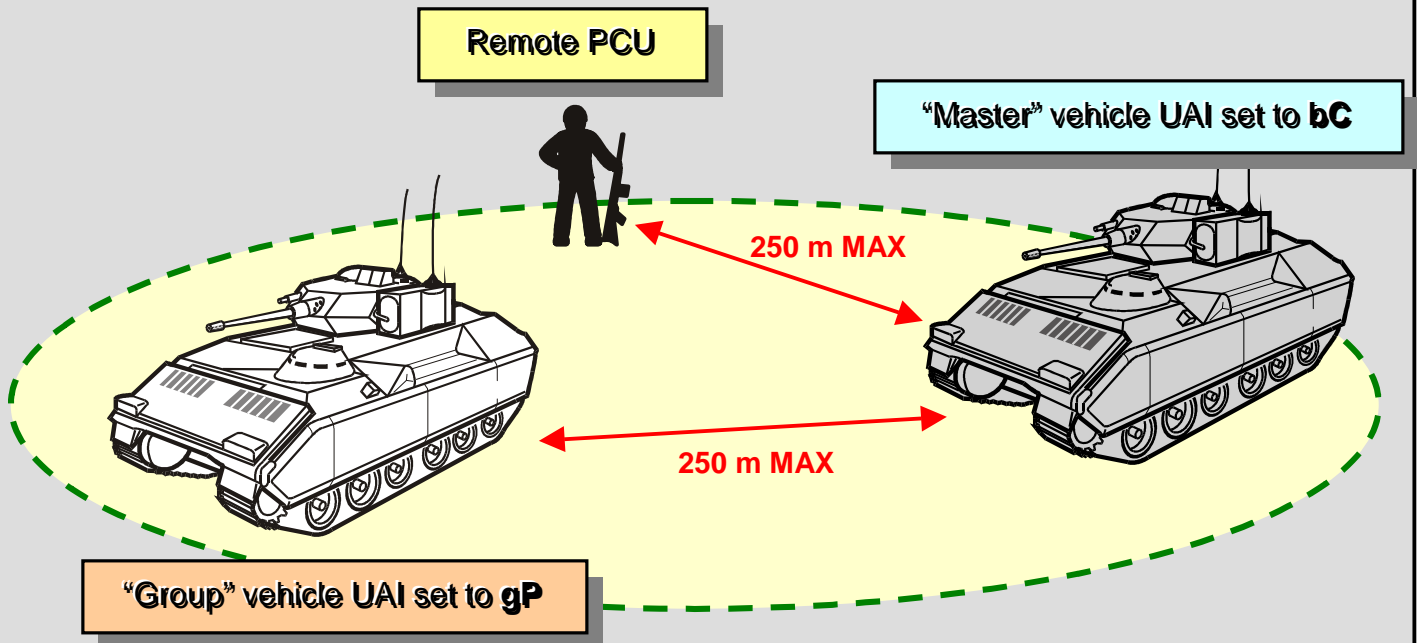

- Vehicle set to Group Mode can communicate with another "master" vehicle *IF* both UAIs are on same channel *AND* master vehicle UAI is set to Broadcast Mode
- "Group" vehicle acts as a single remote PCU on the master vehicle's network
- Remote PCUs become part of master vehicle's network
- Remote PCUs are able to key master vehicle's radio (if access is allowed)
- Maximum Range = 250 meters (LOS)

# — Listening Silence Operating Mode —

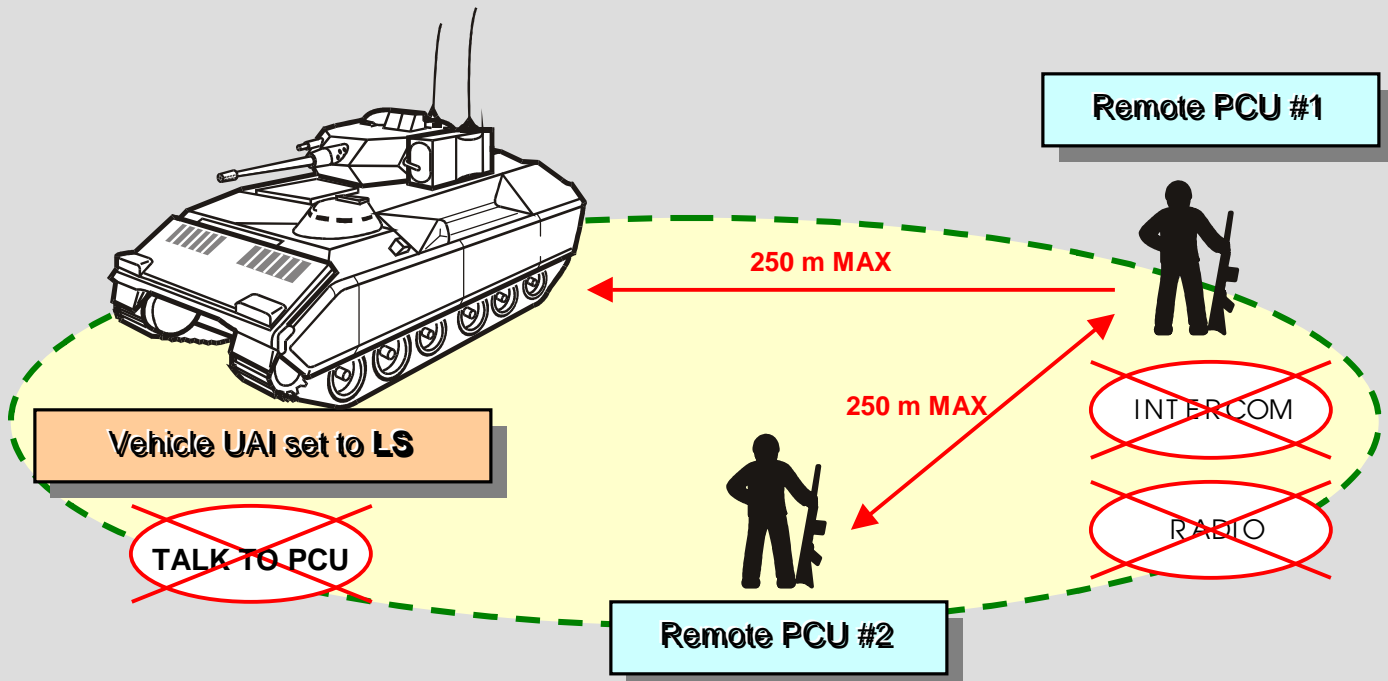

- Only affects communications between vehicle & remote users
- Onboard personnel can listen to remote PCU traffic but cannot talk to remote PCU (*one-way Receive*)
- Remote personnel can talk to vehicle but cannot listen to onboard vehicle traffic (*one-way Transmit*)
- Remote personnel cannot transmit over radio
- Communication between remote users is unaffected
- Maximum Range = 250 meters (LOS)

## — Safety/Usage Considerations



- Ensure all connections are secure prior to use
- Keep PCU & UAI antenna **at least** 20 cm (8 inches) away from individuals w/ pacemaker
- Keep PCU/UAI volume at minimum fully-audible level
- Do not short contacts on battery pack; keep loose batteries away from metal objects
- Cease use of CCS immediately upon erratic or unexpected vehicle behavior.

## — Safety/Usage Considerations —



*(CONTINUED)*

- All critical voice communication should be repeated back to originator
- Changes of setting/mode may result in brief loss of communication (2-4 sec) -- allow PCU display to blank before transmitting
- Removing bailout cable for remote use may result in 6-8 sec loss of comm.
- CCS VOX is less sensitive than wired VIC-3 VOX; may require louder voice/inflection to activate
- Mic boom should be touching lips when talking to ensure VOX is maintained.

## — Safety/Usage Considerations —



*(CONTINUED)*

- Remote personnel will notice static / decrease in signal quality when moving out of range of vehicle (>250 m).
- If comm. is lost due to moving out of range, user may have to move completely back within range of vehicle to recover comm.
- When operating remotely, loss of PCU Power will result in loss of Headset functions (ANR and audio pass-through)
- PCU power must be recycled if headset becomes disconnected from PCU
- UAI power must be recycled is turret power is reset
- Maximum simultaneous **remote** talkers = 4. Current talkers have priority



## — Safety/Usage Considerations —



*(CONTINUED)*

- **Radio access for ALL remote PCUs is determined by settings of FFCS connected to UAI (i.e. Gunner's FFCS)**
- Coordinate assigned channels for each vehicle prior to mission.
- UAIs/PCUs should switch back to assigned channel after Group or Autonomous use
- Channel 64 is reserved for test use
- When powering-on unit, self test display may "blink" indicating unit is resetting, do not attempt use until steady "PA" is seen
- UAI and PCUs must always be on Audio setting ("AU")

## — Safety/Usage Considerations —



*(CONTINUED)*

**NOTE** – This equipment has been tested and found to comply with the limits for a Class A digital device, pursuant to Part 15 of the FCC rules. These limits are designed to provide reasonable protection against harmful interference when the equipment is operated in a commercial environment. This equipment generates, uses and can radiate radio frequency energy and, if not installed and used in accordance with the instructions, may cause harmful interference to radio communications. Operation of this equipment in a residential area is likely to cause harmful interference in which case the user will be required to correct the interference at his own expense.

**WARNING** – Changes or modifications to the Cordless Communication Equipment described herein, not expressly approved by the party responsible for compliance, could void the authority to operate the equipment.

**RF EXPOSURE** – For body worn operation, the PCU has been tested and meets the FCC RF exposure guidelines when used with the Northrop Grumman designated antenna, battery pack and headset, and when less than 2.5 cm separation is maintained between the antenna and the user's body. Use of other accessories may not ensure compliance with FCC RF exposure guidelines.

In order to comply with FCC RF exposure guidelines, the UAI must be installed and operated in such a way that a minimum separation distance of 20 cm is always maintained between the antennas and all persons during normal operation.