

The ELS Upgrade Kit may be used on 6600 POR/PAS and 6700 POR/PAS Series Low Energy Power Operator regardless of arm application. Upgraded Units will have the new user friendly features of a 6900 PowerMatic while eliminating the components associated with the L1 and L2 Limit switches.

It is suggested the unit be installed to door frame and door and functioning properly in a manual mode. Door should be able to be manually opened to the desired opening position and fully close under closer spring force.

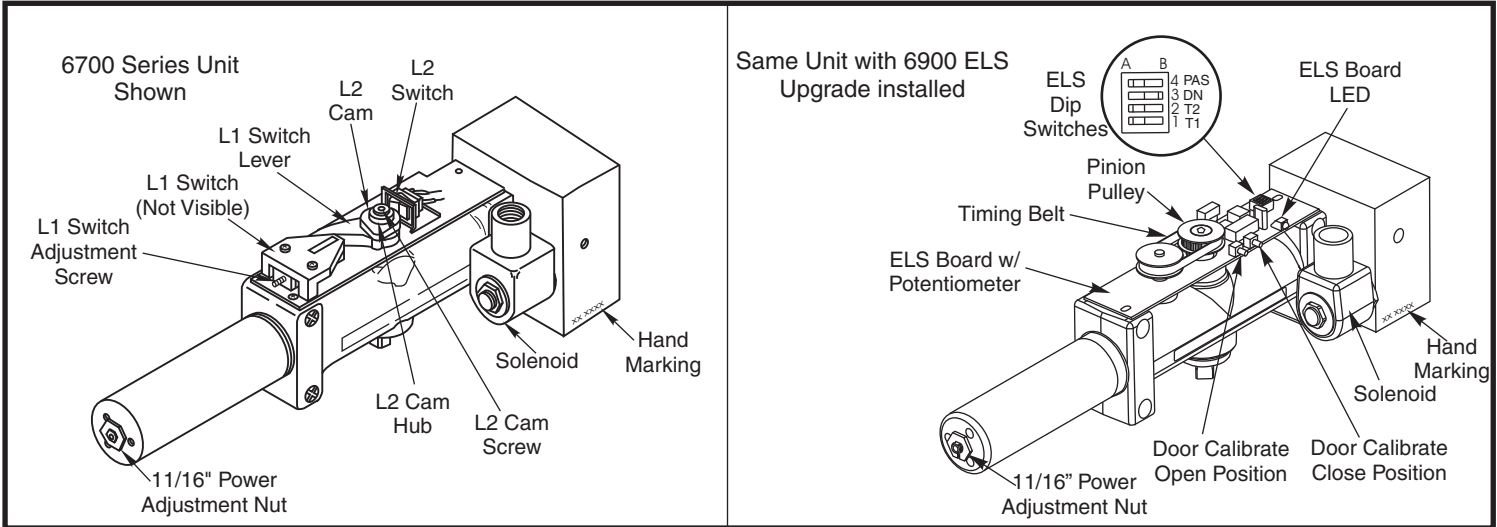

### ELS Modes and Functions:

#### Activation Modes (Modes are configured during installation.)

- **Selectively Activated Mode** - unit depends upon external switches or scanners for activation of functions.
- **Automatically Activated Mode** - unit will operate with a slight movement of the door toward the open position utilizing on-board ELS switching that automatically activates the functions. External switches or scanners may also be used for activation.

#### Functions (Functions are configured during installation.)

- **Power Operator function (POR)** – The unit performs as a low energy power door operator. Field settings allow for following two functions:
  1. Selectively Activated Mode (See Above).
  2. Automatically Activated Mode (See Above).
- **Power Assist function (PAS)** – The unit operates as a standard door closer unless activated. Upon activation the door opening resistance is reduced, for a selected period of time, well below A.D.A. guidelines. When the time period expires, the door closes under normal door closer spring power.

**NOTE:** The ELS Dip Switches are factory set in the Selectively Activated Mode as a Power Operator.

**WARNING**

120 VOLT POTENTIAL MAKE SURE POWER IS  
TURNED OFF DURING INSTALLATION  
PROCEDURE.

Same Unit with 6900 ELS Upgrade installed

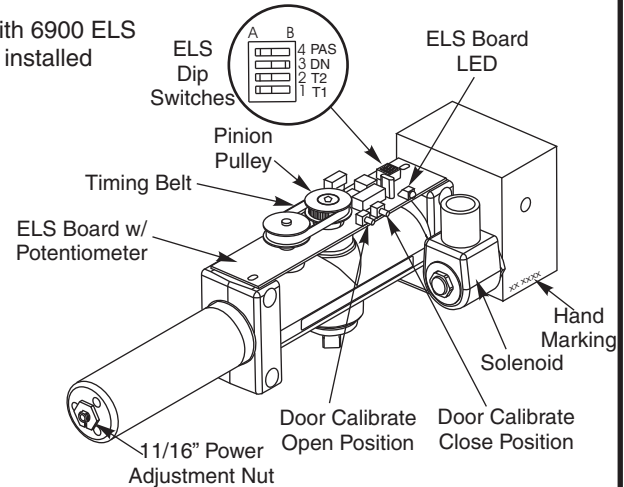

### Americans With Disabilities Act (A.D.A.)

These door operators should be installed and adjusted to conform with A.D.A. regulations.

### ANSI Standards



**ANSI A117.1** – These door operators permit door assemblies to conform to the requirements of this specification "for buildings and facilities – **providing accessibility and usability for physically handicapped people**".

- **ANSI A156.19** – These products are designed to conform to this specification "for **power assist and low energy power operated doors**".
  - "PAS" Mode is designed to meet or exceed all of the requirements for the "Power Assist Door".
  - "POR" Mode is designed to meet or exceed all of the requirements for the "Low Energy Power Operated Door".

### U.L. Listing



**Underwriters Laboratories, Inc. listed for use on fire and smoke barrier door assemblies when the 120VAC (60Hz) power input is supplied through the normally closed alarm contacts of a compatible U.L. Listed alarm system or alarm panel.**

**CAUTION**

An incorrectly installed or improperly adjusted door operator can cause property damage or personal injury. These instructions should be followed to avoid the possibility of misapplication or misadjustment.

**CAUTION**

Kit Contents .....	2
Installation Instructions .....	2-3
ELS Board "TIMING" .....	4
ELS Board "Teaching", Functions and Modes .....	7
Troubleshooting .....	8

**Kit Contents:**

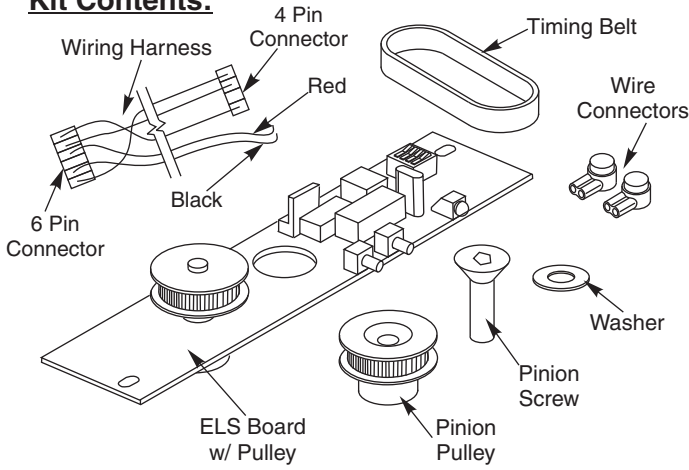

**Installation Instructions:**

**DISCONNECT POWER INPUT TO UNIT AND PLACE THREE POSITION SELECTOR SWITCH TO THE "OFF" POSITION.**

1. Remove the Shrink tube from the Red, Black and Yellow Wires shown in Fig. 1. Carefully cut tie wrap.
2. Unplug the 4-pin connector from the Main Board at JP2 terminal strip that leads to the L2 and L1 switches as shown in Fig.2. Note, 6600's have a L2 Cam Switch only, 6700's have both L1 and L2 switches.
3. Remove L2 Cam Screw with 5/32" hex wrench and remove L2 Cam and L1 Switch Lever (if equipped).
4. Remove Two (2) #8-32 phillips head screws and remove L2 metal switch plate and L1 switch assembly (if so equipped). DO NOT DISCARD #8-32 Screws.
5. Note. You may cut the L1 and L2 wiring harness if this aids in removing the metal L2 switch plate and switch assembly. The red 4-pin connector plug disconnected in the step 2 will not pass under existing tie wraps.
6. Assemble ELS Board to PowerMatic closer body with #8-32 screws removed in step 4 but **DO NOT TIGHTEN** screws at this time.
7. Plug the 6-pin connector of the ELS wiring harness to the ELS board as shown in Fig. 3. This plug is keyed to facilitate assembly. Plug the 4-pin connector of the ELS wiring harness to the JP2 terminal strip on the Main board, replacing the connector removed in step 2.
8. Splice the two remaining RED and BLACK wires of the ELS wiring harness with the RED and BLACK wire removed from the shrink tube in step 1. Splice the RED to RED and the BLACK to BLACK using the two wire connectors supplied with the ELS Upgrade Kit. Slip Joint Pliers or similar tool will be required to seat the connector button. Button should be FLUSH with connector when properly seated. Fig. 4

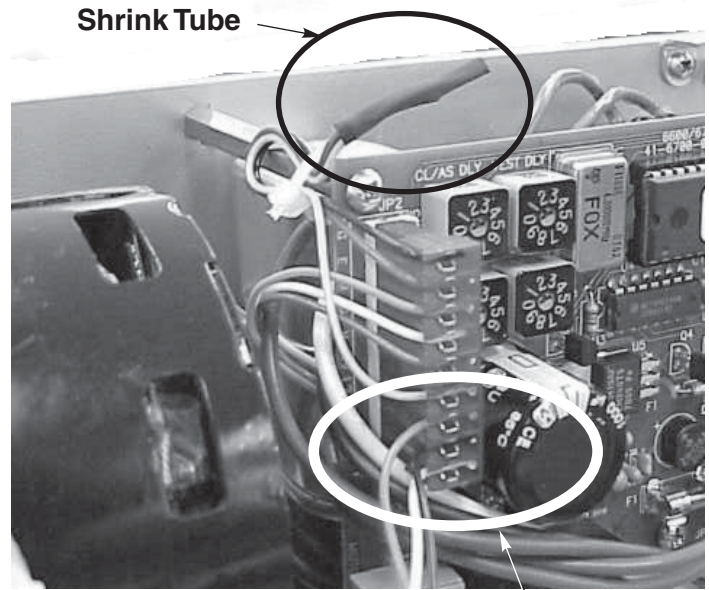

Fig. 1

**JP2 Terminal Strip Connector Four Pins**

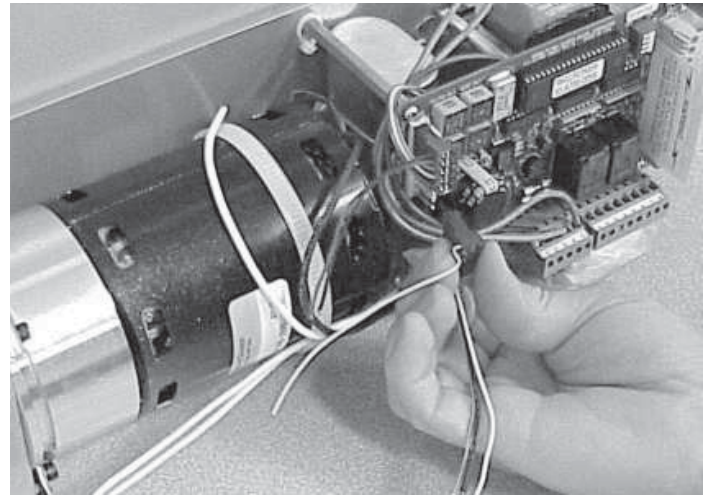

Fig. 2

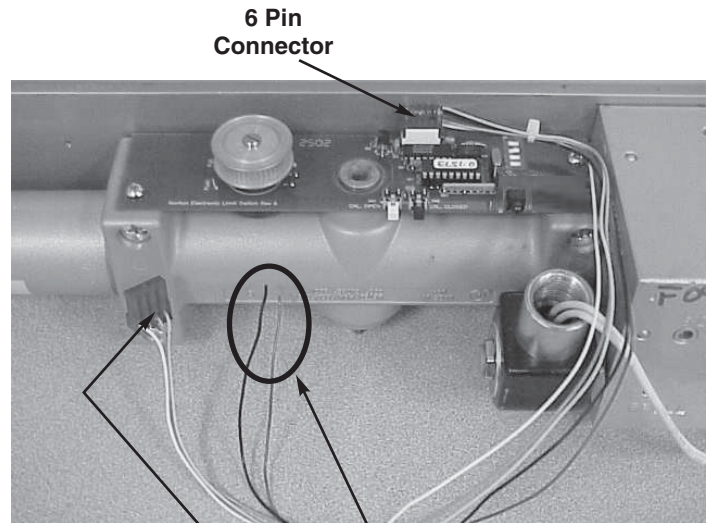

Fig. 3

**Four Pin Connector Wires See Step 8**

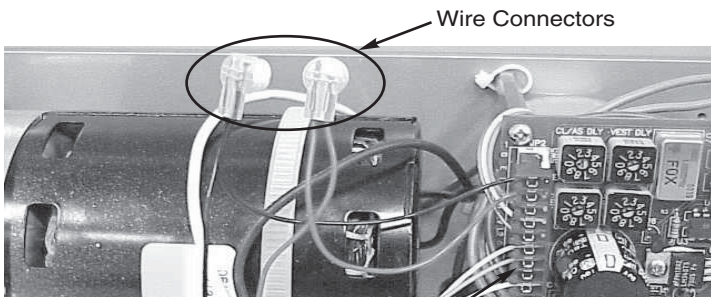

Fig. 4

**4 Pin Connector ELS wiring harness**

## Installation Instructions (cont.):

9. Assemble timing belt to the Pinion Pulley then slip loop of timing belt over the pulley located on the ELS Board. Fig. 5
10. Place wave washer first then the Pinion Pulley onto the Closer Body Pinion. See Fig. 6. Assemble flat head pinion screw supplied using a 5/32" hex wrench. Turn screw until it is close to contacting the Pinion Pulley. Pulley should be able to rotate independent of pinion. ***DO NOT TIGHTEN*** at this time.
11. Carefully slide the ELS board assembly in the direction that will put tension on the timing belt. The proper amount of tension has been achieved when you can deflect the belt 1/16" to 1/8". When the proper tension is present, TIGHTEN the two (2) #8-32 phillips head screws used to attach the ELS board to the closer body in step 6. See Fig. 7.
12. The ELS board assembly is now finished and the board is ready to be "timed".

**NOTE:** The Pinion Pulley should still be able to rotate independent of pinion at this time. Be sure Pinion Pulley screw is not tightened before proceeding. **POWER INPUT SHOULD REMAIN DISCONNECTED.**

13. Proceed to the ELS Board Timing Instructions found on page 4 of this booklet.

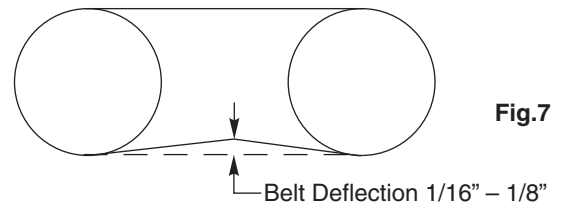
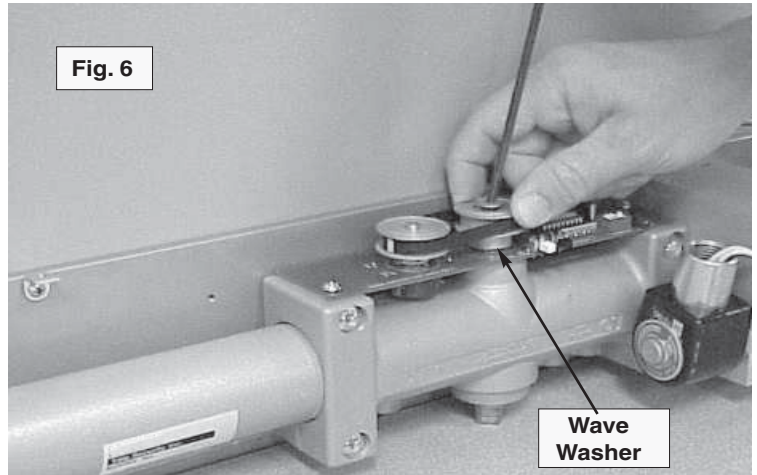
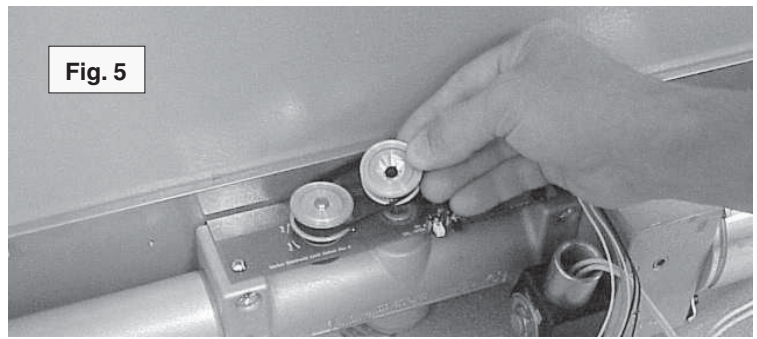

## ELS Board Timing Instructions:

Before the ELS Board can function properly, the ELS Board Pulley must be "timed" to give the board a starting position.

### **READ STEPS COMPLETELY BEFORE PROCEEDING.**



**WARNING:** Make sure Dip Switch #3 on ELS board is in the "A" position and the Selector Mode Switch is in the "OFF" position when timing the ELS board.

\* Power input to unit should be OFF.

**NOTE: IF UNIT IS MOUNTED TO FRAME AND DOOR DURING THE "TIMING" PROCEDURE, THE DOOR MUST BE IN THE FULLY CLOSED POSITION. IF UNIT IS BEING "TIMED" ON THE BENCH (OFF OF FRAME AND DOOR), THE PINION MUST BE IN THE AT REST POSITION (NO PRE-LOAD).**

1. Determine hand of unit. See hand marking found on unit manifold. (See front Page) This information is need to properly time the ELS board.
2. Remove Pre-Load from arm. See instructions based on Hand of Unit. See Page 5 and 6
3. Rotate ELS Board Pulley in the direction shown in the [Timing Chart](#) based on the [Hand of Unit](#) (Step 1) you are Upgrading. Rotate pulley until a [Hard Stop](#) is felt. The pinion pulley should have been rotating as well due to the timing belt.
4. \*\* Depress and hold **Black Button** on the ELS Board. While depressing button, turn power input to unit "ON". Continue depressing button until the ELS Board LED flashes three(3) times. The installer then has three (3) seconds to release the button after LED flashes.
5. Slowly rotate ELS Board Pulley in opposite direction from step 3 (away from Hard Stop) until ELS board LED lights. The amount of rotation required to light the LED should be less than 1/8 th of a turn; if not repeat step 3. The lighted LED indicates the board is in the "timed" zone for that Hand of Unit.
6. Hold the Pinion Pulley stationary while tightening the pinion screw with a 5/32" hex wrench. If LED turns off during this tightening procedure without significant movement of pulley (less than 1/8 turn), this is not a problem. The timing zone range in larger than the zone that keeps the LED lit.
7. Pre-Load arm. See instructions based on Hand of Unit. See Page 5 and 6
8. The ELS Board is now Timed. Proceed to the [Teaching Closed and Open Door Positions](#) found on page 7 of this booklet.

## Timing Chart

Hand of Unit	Direction of Rotation To Hard Stop
LH-PUSH	Clockwise CW
RH-PUSH	Counter clockwise CCW
LH-PULL	Clockwise CW
RH-PULL	Counter clockwise CCW

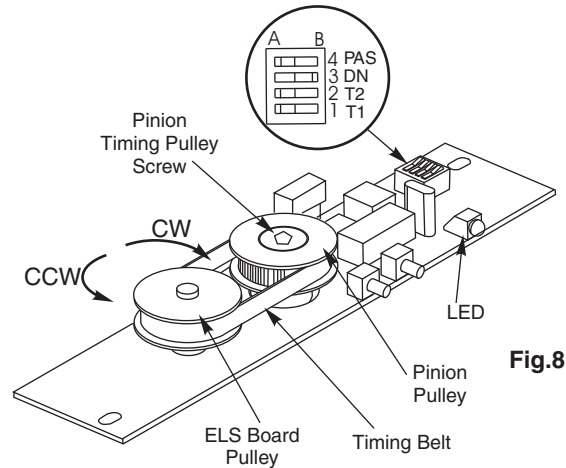
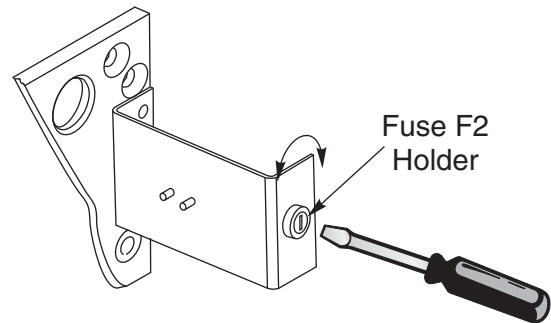

Fig.8

### \* Disconnecting Power to Unit

If power input does not have a interrupt switch near by, power may be terminated at unit by unseating Fuse F2.

- Choose a flat blade screw driver that will fit snugly into slot on fuse holder
- Carefully push on Fuse Holder cap while turning Counter-Clockwise 1/4 turn to unseat fuse holder cap. Gently pull cap out slightly and note if LED on Main Board is Lit. If there is no Light, Power input to unit has been disrupted.
- To reseal fuse, Carefully push fuse holder cap into holder and turn Clockwise 1/4 turn.



### \*\* NOTE:

When performing [Step 4](#) of ELS Timing Instructions, you may push on Fuse Holder Cap with screw driver to temporarily engage power so that attention can be directed at the ELS LED. Once the LED has flashed 3 times and the BLACK button released, then the installer may properly reseal the fuse per instructions above.

## LH-PUSH / RH-PUSH – PRE-LOAD INSTRUCTIONS

### REMOVING PRE-LOAD.

- Door should be in the fully closed position.
- Loosen 1/4-20 located on Arm Slide.
- Allow main arm to rotate toward the hinge until main arm is 90° with door frame.

Fig.10 shown here for reference is case main arm is removed for some reason during upgrade. Fig.10 shows proper Main Arm and Pinion configuration.

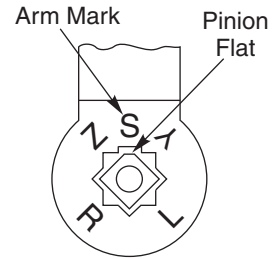
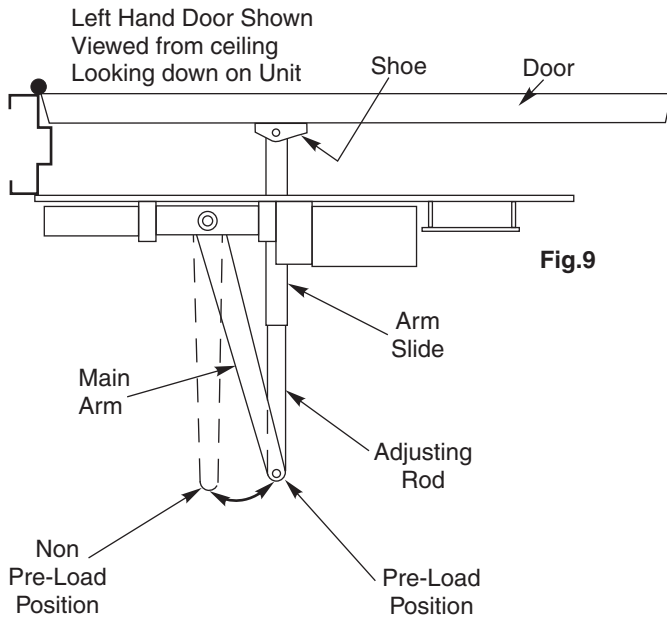

### ADDING PRE-LOAD TO PUSH TYPE ARM.

- Door should be in the fully closed position.
- Rotate the Main Arm away from the hinge until the adjusting rod and arm slide are perpendicular (at a 90° angle) to the door frame.
- Tighten the 1/4-20 screw located on the Arm Slide.

## LH-PULL / RH-PULL – PRE-LOAD INSTRUCTIONS

### REMOVING PRE-LOAD.

- Door should be in the fully closed position.
- Close Valves “S” and “L” located on bottom side of Manifold using 1/8” hex wrench, turn valves clockwise until interference is felt.
- Open door to gain access to top of slide track. Using a flat blade screw driver, extend the retaining clip approximately 3/8” and pull up on arm until arm stud in free of Slider. (Fig.14)
- Loosen and remove the Main Arm screw and washer using a #3 Phillips drive and remove Main Arm.
- Open Valves “S” and “L” located on Manifold. Turn valves counter-clockwise until head of valve is flush with Manifold. Once the Pinion has stopped rotating the pre-load has been removed.

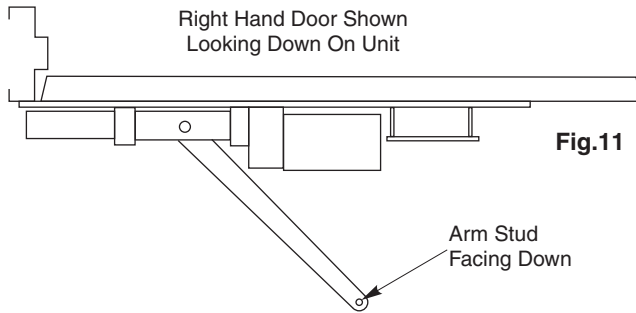

### ADDING PRE-LOAD TO PULL TYPE ARM

- Close Valves “S” and “L” located on bottom side of Manifold using 1/8” hex wrench, turn valves clockwise until interference is felt.
- Place closer arm on the closer pinion with arm at a 45° angle to frame face and the arm stud away from hinge. (Fig.11)
- Rotate arm toward hinge to a position approximately a 100° from frame face. (Fig.12)
- Remove arm and reinstall it on the pinion with the arm almost parallel to the frame face, this should be done before the pinion shaft can rotate far enough to create arm interference with the frame face. (Fig.13)
- Install and tighten Main Arm Washer and Screw (1/4-20 x 1/2” long No. 3 Phillips Drive).
- Open door to gain access to top of slide track. Check to see if retaining clip is extended approximately 3/8”. Insert Arm Stud into Slider until it clicks in place. And secure arm by pushing on the retaining clip until it is flush with the slider. (Fig.14 & Fig.15)
- Adjust valves “S” and “L”. Using 1/8” hex wrench, turn valves counter clockwise. Do Not Remove Valves from Manifold. Adjust valve “S” first and then valve “L” until desired speeds are achieved. A.D.A. requires that from an open position of 70° the door will take at least 3 seconds to move to a point 3” (76mm) from the latched position, measured at the leading edge of the door.

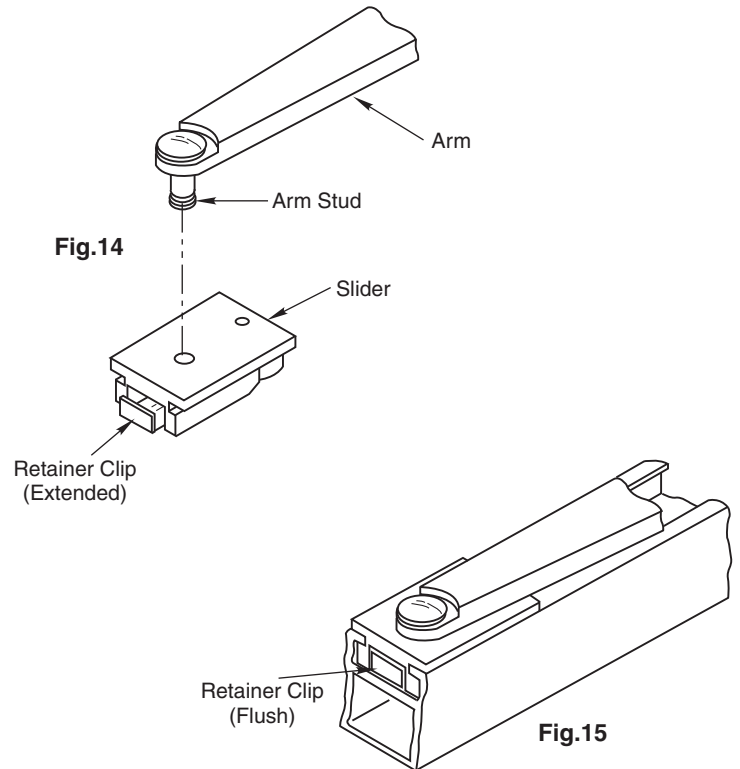
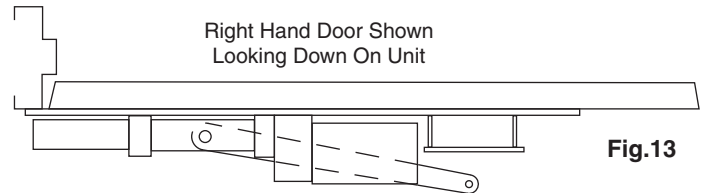
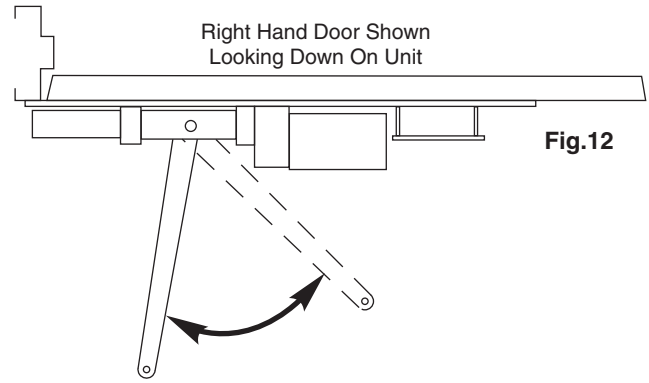

### IMPORTANT

- **Power Operator Function Only:** The opening speed of the door from closed position to 80 degrees must be 3 seconds or longer and 4 seconds or longer to the fully open position.
- **Power Operator Function Only:** The force required to prevent a door from opening or closing must not exceed a 15lbf. (67N) applied 1” (25mm) from the latch edge of the door at any point in the opening or closing cycle.

## TEACHING CLOSED AND OPEN DOOR POSITIONS:

Before operating, the PowerMatic ELS must be “taught” the fully closed and fully open door positions.

**WARNING:** Verify that dip switch #3 on the ELS board is in the “A” position to disable the Push and Go Feature. Three position Selector Switch should be in the “OFF” position.

1. With the door fully closed, press and release the BLACK pushbutton on the ELS board. The ELS system will store this position as closed and begin the 10 second “Teaching Mode”.
2. Within the 10 second time frame, manually open the door to the desired fully open position. While holding the door open in this position, press and release the WHITE pushbutton on the ELS board. The ELS system will store this position as open.
3. Let the door close hydraulically to the closed position. This will end the “Teaching Mode” whether or not the 10 seconds have elapsed.
4. Turn the three position selector switch to the “ON” position for normal operation or the “HO” position for infinite Hold Open.

## Activation Mode – (Push and Go)

Mode	Push And Go	ELS Dip SW 3
Selectively Activated	DISABLED	A
Automatically Activated	ENABLED	B

## Functions – Power Operator / Power Assist:

Function	ELS Board Dip Sw 4	Main Board Dip SW 1
Power Operator	B	OFF
Power Assist	A	ON

- Rotate the “SC” Valve Counter-Clockwise to adjust opening force.
  - Rotate the “PA” Valve Clockwise if needed to adjust pressure.
- Adjust the “SC and “PA” valves so the the door does not open when activated, but opening force is reduced below A.D.A requirements for Power Assisted Opening.  
(See illustrations on page 2 for locations of Dip Switches and Valves.

## Obstruction Operation:

### Obstruction During Opening:

The unit will shut down and the door will close.

### Obstruction During Closing:

The unit will reopen the door. If the Obstruction During Closing is detected a second time, the door will not attempt to reopen and will close.

### Obstruction Sensitivity

The sensitivity of the obstruction feature can be adjusted in the field as required. The unit has been factory-configured to respond immediately to an obstruction. In certain applications where excessive wind or excessive stack pressure is present, a delay of 1, 3, or 5 seconds can be selected by toggling dip switches #1 and #2 on the ELS board.

Time	Dip Switch T1	Dip Switch T2
Immediate	B	B
1 Sec.	A	B
3 Sec.	B	A
5 Sec.	A	A

## Adjustments for the PowerMatic Product

The following adjustments mechanical, hydraulic and electrical are listed in a suggested sequence.

**NOTE:** Make sure that power to unit is OFF.

## MECHANICAL ADJUSTMENT

- Set Closing Power. Use 11/16" wrench or socket. Turn Power Adjustment Nut clockwise to increase door closing power. Door control is shipped set at midpoint of power setting. Maximum closing power can be achieved with 5 (360°) turns of the power adjustment nut for a regular PowerMatic, 7 turns if unit is a Barrier Free (BF) unit.

## HYDRAULIC ADJUSTMENT – Use 1/8" hex wrench

- Closing Cycle – Make adjustments, as necessary, to the Sweep Speed “S” valve and Latch Speed “L” valve. See illustration on Page 2. Turn valves clockwise to reduce speed, counter clockwise to increase speed.

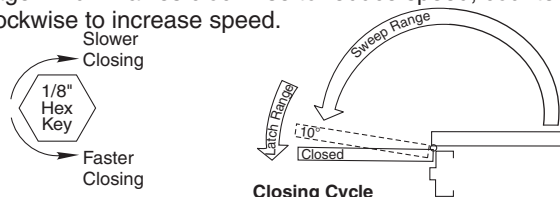

- Opening Cycle – Adjust Backcheck, “B” valve, as necessary, for hydraulic resistance to door opening in the backcheck range. See illustration on Page 2.

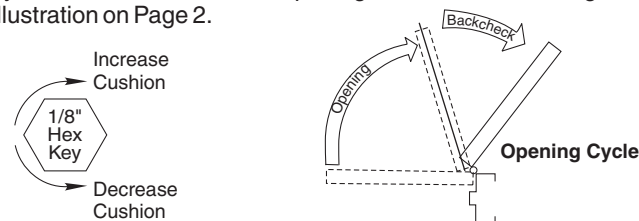

**NOTE:** Too much Backcheck, “B” valve, can affect the operation of the units pump, preventing units from fully opening the door. This valve may require fine tuning after all other adjustments have been made.

- Backcheck Position “P” valve is closed. Open by turning counter clockwise, only if backcheck cushioning is required to begin at a greater degree of door opening than the approximately 75° it is set for.

## ELECTRICAL:

Turn power input to unit on.

Selector Mode Switch – Set to the “ON” Position for normal use.

- Adjust “CL/AS DLY” Rotary Switch/Timer Pot on the printed circuit board as necessary using a standard screwdriver with a 1/8" wide blade. Adjustable for 0 to 30 seconds (see chart below).
- Power Assist Function Only:  
Adjusts the length of time the motor will assist with opening from the time the motor is activated.
- Power Operator Function Only:  
Adjusts the length of time the door remains at the fully open position after the operator function shuts off.

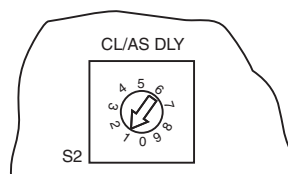

Illustration for CL/AS DLY Rotary Switch/Timer Pot From Printed Circuit Board

Length of Time (Seconds)	Setting
0	0
2	1
5	2
10	3
15	4
20	5
25	6
30	7

- If desired, install No. 668 Security Plate over notch in cover to conceal the Selector Mode Switch when cover is installed.
- Install cover with mounting screws removed at beginning of installation.

## Troubleshooting

1. After installation; PowerMatic does not respond to input signal to open door i.e. wall switch, card reader, etc.
  - a. Verify unit's input power is connected (LED lit on Main Board)
  - b. Verify unit's 3 position switch is in the "ON" position.
  - c. Verify that the splices made during installation are indeed RED to RED and BLACK to BLACK. See page 2.
  - c. Verify follow: Look at terminal JP2 on Main Board
    1. Verify that Terminal "G" has a Black wire
    2. Verify that Terminal "E" has a Red wire.If the wire colors are not correct, swap the wires.
2. The PowerMatic's motor turns on and opens the door if the door is slightly pushed or pulled without any external devices i.e. wall switch sending a signal to open.
  - a. The 6600 series unit didn't have this feature. The 6900 upgrade gives you the "push and go" feature that used to be present on the 6700 series only. If this feature is not wanted, set the DIP Switch SW3-3 DN on the ELS board to the "A" position.
3. PowerMatic "Push and GO" feature is not operational.
  - a. Verify that Dip Switch SW3-3 DN on ELS Board is in the "B" position.
4. PowerMatic does not respond to taught positions i.e. door does not stop at the taught "Fully Open" position, but continues to travel until it hits a stop; motor than continues to run for a few seconds after stop is hit.
  - a. Was unit properly taught. See page 7.
  - b. Verify that RED and BLACK wires were properly spliced as per instruction 8 on page 2. If wires are spliced, check continuity of Red and Black wires across splice with meter.
5. PowerMatic Motor shuts off and door closes before reaching full open position.
  - a. This could be caused by the unit sensing an obstruction on Opening.
    1. Verify door can be mechanically opened; check for frame interference.
    2. Check Backcheck setting on closer body. If Backcheck is too strong, unit may be seeing this as an obstruction.
    3. Check "SC" (Speed Control) Valve setting. Door may be opening too slowly. Turn "SC" valve clockwise to increase speed.
    4. There may be wind or some other positive pressure present. Adjust Obstruction Sensitivity to a longer time setting. See page 7.
6. PowerMatic Motor turns on and re-activates door before it reaches jamb or closed position.
  - a. This could be caused by the unit sensing an obstruction on Closing.
    1. Check for frame interference.
    2. Verify the transition from sweep speed to latch speed is smooth. If there is an abrupt change in speed or if door stops as it transitions from sweep to latch, the unit will see this as an obstruction.
    4. There may be a wind or some other positive pressure present. Adjust Obstruction Sensitivity to a longer time setting. See page 7.
7. If the unit does not respond to taught positions; is not responsive to different hold open times and troubleshooting step 4 did not solve the issue, the potentiometer connected to the ELS board pulley may have been damaged during the upgrade.
  - a. Verify the hard stop that was discussed during the ELS Board Timing Instructions (page 4 step 2) has not been broken.
    1. Place the 3 Position Switch in the "OFF" position. Disconnect power input to unit. (See page 4). Hold the Pinion Pulley securely and loosen the Pinion pulley screw so that the pulley is free to turn independent of the pinion.
    2. Proceed to the ELS Board Timing Instructions on page 4 and re-time unit. If hard stop is not present contact factory.