



# INSTALLATION

## TABLE OF CONTENTS

<b>INSTALLATION</b>	<b>PAGE</b>
Contents of Carton .....	3
Precautions and Guidelines .....	3
Wiring Specifications .....	3
Remote Station Wiring .....	3
Maximum Number of Remote Stations .....	3
Mounting the Terminal Board .....	4
Connecting the Remote Wiring .....	4
Connecting Volume Control Wiring .....	5
Connecting Door Speaker Wiring .....	5
Preparing Master Station Panel for Optional Door Release Pushbutton .....	5
Mounting the Optional Chime Module in the Master Station Panel .....	5, 6
Mounting the Master Station .....	6
Connecting the Power Transformers .....	7
Mounting the Transformer Cover .....	7
Connecting the Master Station to the Terminal Board .....	8
Connecting the Radio Antenna .....	9
Connecting the Optional Chime Module .....	9
Connecting Optional Electronic Chime .....	9
Connecting Optional Accessories .....	10
Connecting Power to the Optional CP-95 Cassette Player .....	10
Mounting and Connecting Optional Door Release Pushbutton .....	11
Connecting the Memory Back Up Battery .....	11
Securing the Master Panel .....	11
Powering Up the System .....	11
<b>OPERATIONAL CHECKOUT</b>	
System Operating Controls .....	12
Digital Clock .....	13
System Checkout .....	13
Setting Program Audio Controls .....	13, 14
Setting Intercom Volume .....	14
Setting Internal Intercom Volume Control .....	14
Setting the BEEP Tone Level .....	14
Setting the External Audio Source Level .....	14
Diagnostic Tests .....	15
Resetting the Microprocessor .....	15
<b>INSTALLER'S TROUBLESHOOTNG GUIDE</b> .....	16, 17, 18
<b>WARRANTY</b> .....	20

# INSTALLATION

## CONTENTS OF CARTON

Check (✓) for the following IMA-4406 carton contents.

- IMA-4406 master station
- Terminal board
- Transformer cover
- Hardware bag assembly containing:
  - 2 - shoulder screws
  - 12 - No. 6 x 3/8 screws
  - 4 - colored panel mounting screws
  - 4 - 'L' panel mounting brackets
- Homeowner's manual with room labels
- Installation instructions
- Product Registration Warranty Card

**NOTE TO INSTALLER: Do not discard these installation instructions. Please transfer all installation instructions, warranty registration and homeowner's manual to the homeowner.**

## PRECAUTIONS AND GUIDELINES

The NuTone IMA-4406 master station has been designed for ease of installation. Please read and follow ALL installation instructions, guidelines and precautions. Any deviation from these instructions or miswiring combinations may result in unit failure and void of warranty.

### **WARNING!**

**120 Volt AC Power to Transformers in the IR-105 Rough-in MUST Remain OFF until ALL System Wiring at the Master and Remote Stations is Complete.**

- Observe all local building regulatory codes in your area.
- All screw terminals at the master and remote stations must be secure.
- Observe all color code connections of wires when connecting the remote stations to the master.
- The IMA-4406 is designed to be installed with only NuTone specified wire. No other wire should be used. The use of wire other than NuTone wire will void all NuTone warranties and may result in faulty installation and improper operation.

### **IMPORTANT WARNING!**

**THE POWER TRANSFORMER CONTAINS AN INTERNAL FUSE.**

**DO NOT SHORT THE LOW VOLTAGE CONNECTING SCREWS OF THE TRANSFORMER OR THE TRANSFORMER WILL BE DESTROYED!**

## WIRING SPECIFICATIONS

See the IR-105 master rough-in frame installation instructions for detailed wiring information.

Use NuTone IW-6, 3 twisted pair for connecting:

- Remote controls to master
- Remote stations to master

Use NuTone IW-2, 22 ga. twisted pair for connecting:

- Door speakers to master
- Remote controls to speakers
- Speaker volume control (IC901) to master
- Speaker volume control (IC901) to speakers
- Electronic chime audio output to master
- Pushbutton to chime module

Use NuTone S-143, 18 ga. twisted pair for connecting:

- Pushbutton to electronic chime
- Electronic chime to chime transformer

Use №14/2 power cable with ground, Class 1 UL Listed (Observe local codes) for connecting:

- Transformers to 120v AC

Use shielded audio cable for connecting external audio sources to the master station.

## REMOTE STATION WIRING

An individual 6-wire cable (IW-6) must be connected from each remote station or remote control location to the master station's terminal board.

Maximum station wire length: 750 ft.

**IMPORTANT! NuTone cannot be responsible for improper system operation that results from interference generated by light dimmers, fluorescent lighting fixtures, and similar electrical products. Such interference must be corrected at the source. TO HELP REDUCE THIS INTERFERENCE, ALL WIRING CONNECTIONS TO THE MASTER MUST BE PLACED AT LEAST 12 INCHES FROM ANY AC POWER WIRING. AVOID RUNNING INTERCOM WIRES PARALLEL TO AC POWER WIRING.**

Maximum total length of IW-6 cable per system: 4,000 ft.

## MAXIMUM NUMBER OF REMOTE STATIONS

The master station will accommodate up to 9 connections at the terminal board. These connections can be any combination of remote stations, remote controls or volume

**NOTE: NEVER connect more than one remote station to a set of screw terminals.**

controls. It will also accommodate 3 door speaker connections.

If more than 9 stations are required, use the optional Model № IAA-440 expansion kit. This will allow an additional 6 connections at the master.

# INSTALLATION (Continued)

**WARNING! NEVER EXCEED A TOTAL OF 15 NUTONE 25 OHM SPEAKERS ON THIS SYSTEM.**

**WARNING! NEVER USE STANDARD 8 OHM STEREO SPEAKERS ON THIS SYSTEM. USE ONLY NUTONE SPECIFIED SPEAKERS ON THIS MASTER.**

## MOUNTING THE TERMINAL BOARD

1. Remove and clean any drywall debris or dust from the rough-in before beginning installation.
2. **Refer to Figure 1.** Locate the terminal board in the left rear section of the rough-in frame.
3. Use four (4) N° 6 x 3/8" screws supplied to secure the terminal board to the rough-in frame.
4. Make certain the lower right-hand screw is secure and snug against the ground lug which covers the mounting hole in the terminal board. Do not bend ground lug. Make sure it is positioned between the screw and terminal board.

### ▶ IMPORTANT ◀

**DO NOT APPLY POWER TO THE SYSTEM UNTIL ALL CONNECTIONS ARE COMPLETE AT THE MASTER AND REMOTE STATIONS.**

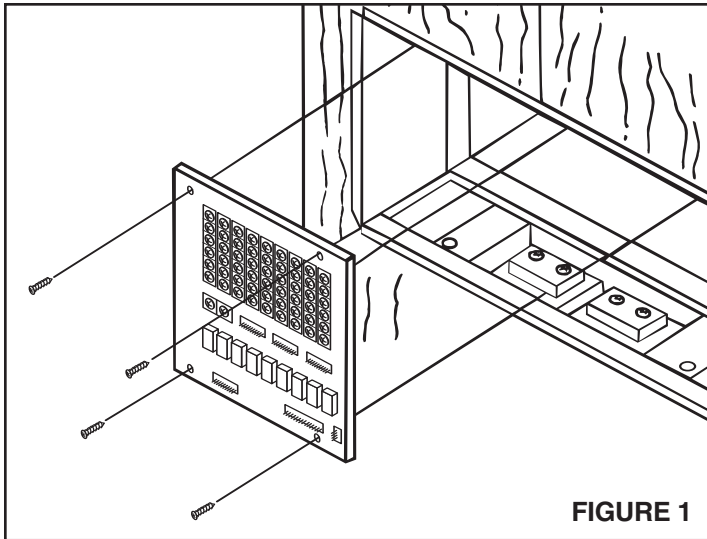

FIGURE 1

**All Remote Stations, Remote Controls, Speaker Volume Controls, and Door Speaker Wiring MUST Return Directly to the Master Station. DO NOT CONNECT WIRING FROM SPEAKER TO SPEAKER!**

## CONNECTING THE REMOTE WIRING

1. Dress all remote wiring through the rectangular holes in the upper right and left sides of the rough-in frame. All wiring connections are made to the master station's terminal board.

2. **Refer to Figure 2.** Connect the IW-6 cable from each remote to the appropriate set of terminal screws at the master station's terminal board. When connecting the cable to the terminal board, be sure to observe the matching of all color codes.

**Connect:** RED to RED  
 RED/WHT to RED/WHT  
 BLK to BLK  
 BLK/WHT to BLK/WHT  
 ORN to ORN  
 ORN/WHT to ORN/WHT

Only connect **one** remote to each set of screw terminals. After completing all connections, check for any shorted wires. Dress cables flat against the terminal board to allow space for the master station to be properly secured.

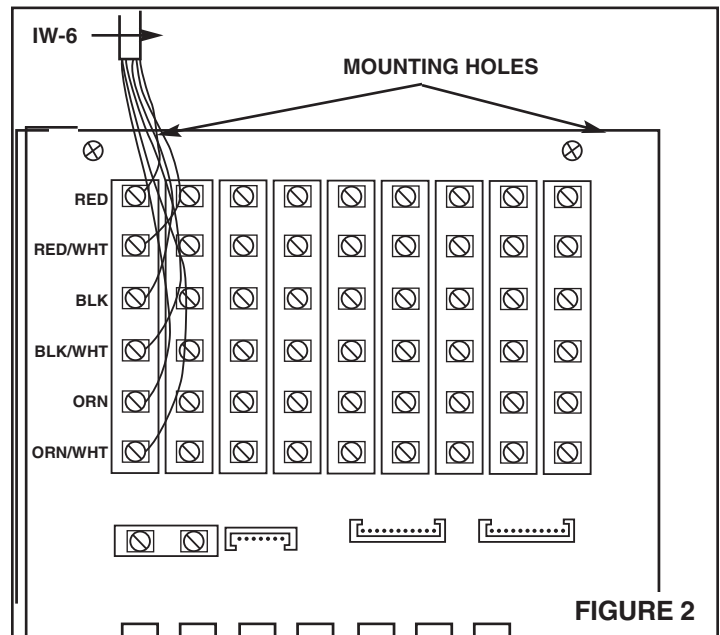

FIGURE 2

3. Refer to installation instructions packaged with the remote stations and remote controls for wiring these units.
4. **Refer to Figure 3.** Use the Wire Matching Chart if you are retro-fitting a system with the previously used IW-6R cable.

### IMPORTANT – WHEN NUTONE MODEL IW-6R WIRING IS USED:

**CONNECT TO THE SCREW TERMINALS ON THE TERMINAL BOARD MARKED:**

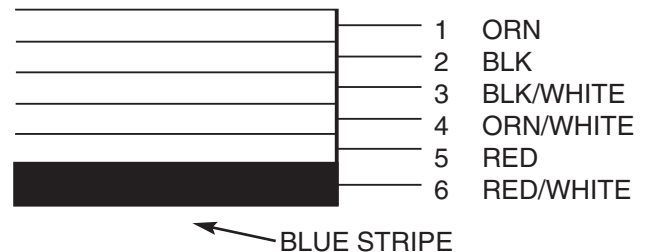

FIGURE 3

## CONNECTING VOLUME CONTROL WIRING

# INSTALLATION (Continued)

Refer to Figure 4. If a NuTone Volume Control is installed in the system, connect the control's IW-2 wiring to the ORN and ORN/WHT screw terminals at the master station. **Only ONE NuTone speaker may be connected to each volume control. Each volume control/speaker counts as a remote station. Remember: The maximum remote connections to the Master Station is 9. Adding the optional IAA-440 expansion module will increase the system remote capability to 15 stations.**

Refer to the installation instructions packed with the speaker

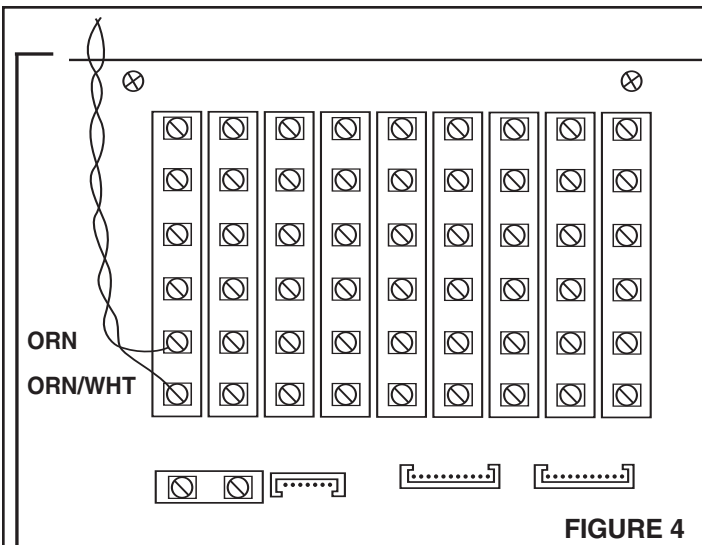

**NEVER USE 8 OHM STEREO SPEAKERS WITH THIS SYSTEM!**

volume control for wiring this unit.

## CONNECTING DOOR SPEAKER WIRING

The Door Speakers connect to the Master Station Terminal Board with twisted pair IW-2 wire.

1. Refer to Figure 5. Connect the two wires from the Door Speaker(s) to the 2 screw terminals marked **DOOR SPEAKER** on the master station terminal board.

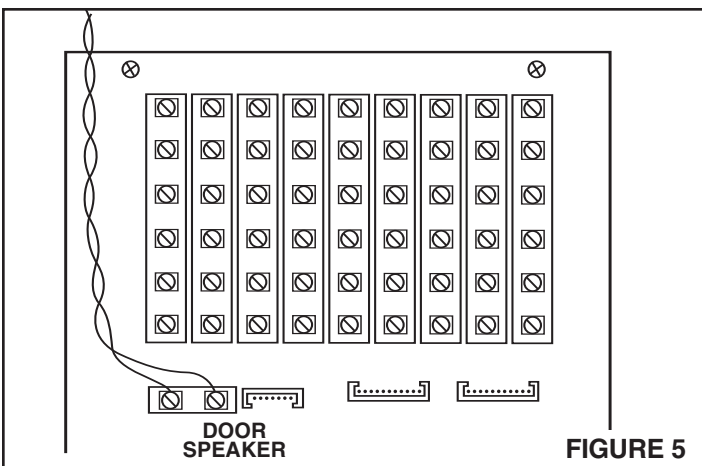

## PREPARING MASTER STATION PANEL FOR OPTIONAL DOOR RELEASE PUSHBUTTON

To remove the pushbutton cover, position the master station face up. Be careful not to damage the cables on the back of the unit.

1. Refer to Figure 6. Open the left-hand door on the master station panel.

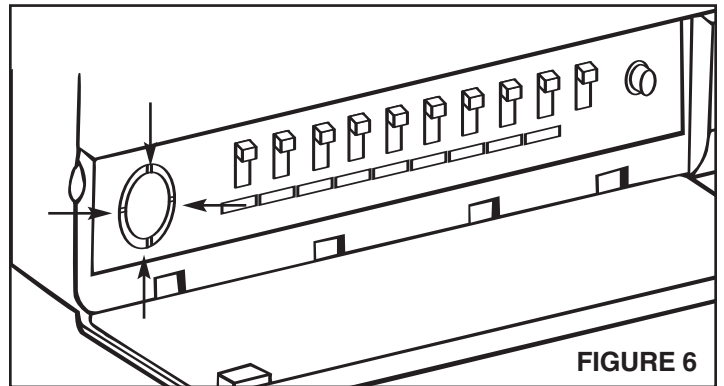

2. Cut the 4 retainer webs from the pushbutton cover.
3. Remove cover. The door release pushbutton will be installed and connected after the master panel has been mounted to the rough-in frame.

## MOUNTING THE OPTIONAL CHIME MODULE IN THE MASTER STATION PANEL

1. Position the master station panel face down on a soft cloth.
2. Refer to Figure 7. Align the optional NuTone IA-28 or IA-29 chime module onto the mounting bracket located in the master station.

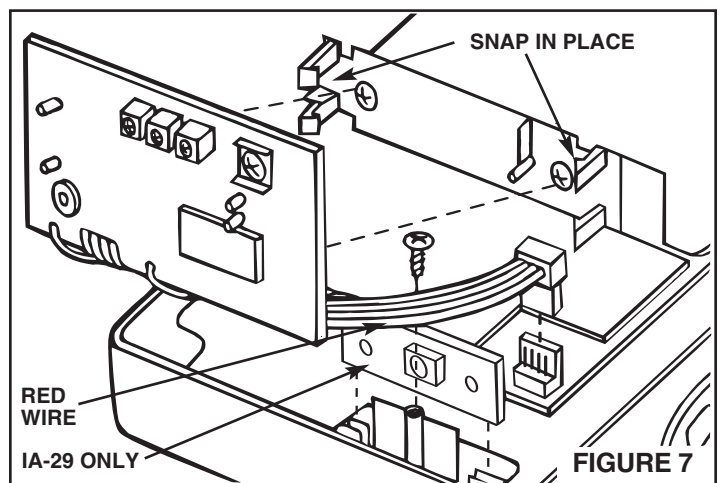

3. Apply firm, but even pressure to each side of the chime module until it snaps into place.
4. Plug the 4 pin connector on the module into the connector located on the master. When properly installed, the ribbon cable will point away from the master station's circuit boards, as illustrated.
5. Connection from the pushbuttons to the master will be made after the master panel has been mounted.

# INSTALLATION (Continued)

## Model IA-29 Only

1. Refer to Figure 8. Locate the chime selector switch mounting bracket in the master unit.

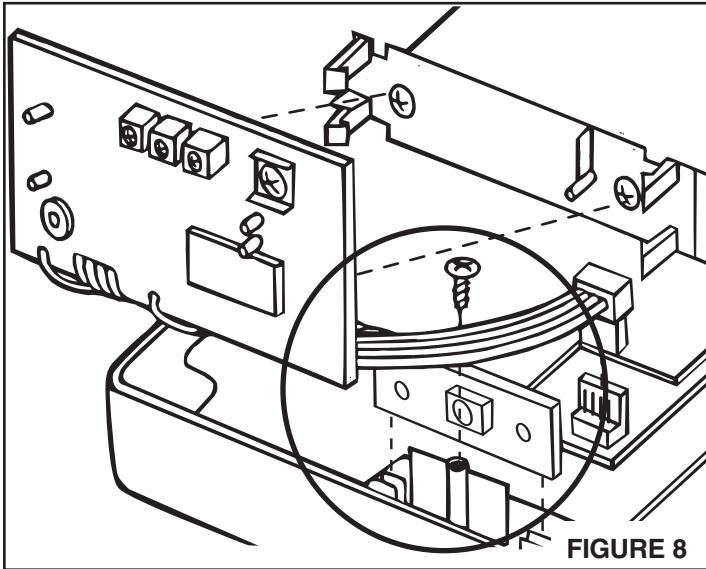

FIGURE 8

2. Remove and set aside the chime selector switch retaining screw located in the master unit.
3. Remove and discard the square foam pads on the chime selector switch PC board connected to the chime module.
4. Slide the PC board into the mounting bracket on the master station.
5. Fasten the chime selector switch PC board with the retaining screw (earlier removed).

## MOUNTING THE MASTER STATION

**NOTE:** If an optional IAA-440 expansion module is to be installed into the IMA-4406 master station, it should be installed before mounting the master station. Refer the installation instruction provided with the expansion module before performing the following mounting steps.

1. Refer to Figure 9. Use two (2) #6x $\frac{3}{8}$ " screws per bracket to attach each of the four (4) mounting brackets to the rough-in frame. Before tightening, slide the bracket so it is flush with the wall surface (flush with rough-in frame if the rough-in is installed after the wall board). Tighten all eight (8) screws.

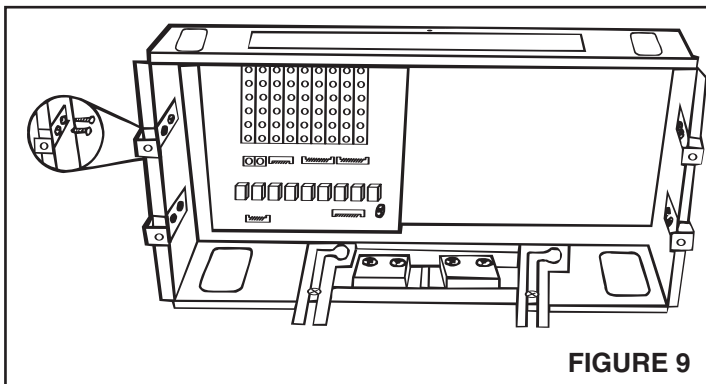

FIGURE 9

2. Refer to Figure 10A and 10B. For rough-in frames which are recessed into the wall opening, insert two (2) shoulder screws (provided) into the front two holes in the rough-in frame. For rough-in frames which are mounted flush with the wall, insert two (2) shoulder screws into the back two holes in the rough-in frame.

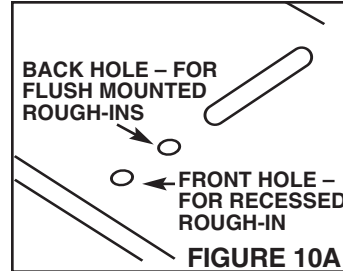

FIGURE 10A

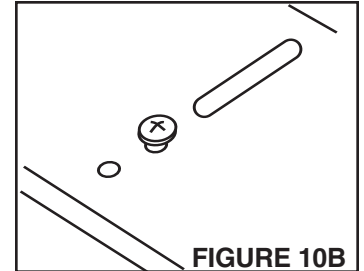

FIGURE 10B

3. Refer to Figure 11. Attach master panel to rough-in frame by placing mounting hinge keyhole slots over shoulder screw heads in the rough-in frame.
4. Refer to Figure 12. Slide master station panel to the right, then forward until it is flush with the wall surface.
5. Align master panel with rough-in frame.

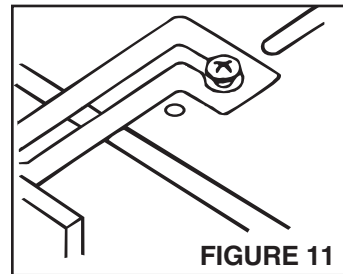

FIGURE 11

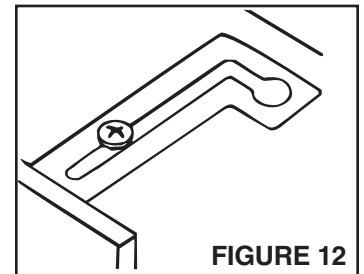

FIGURE 12

6. Refer to Figure 13. Attach support strap to rough-in frame by attaching metal hook into hole in top of rough-in frame. Using pliers, squeeze hook closed. Hook must not come loose when master is later secured.

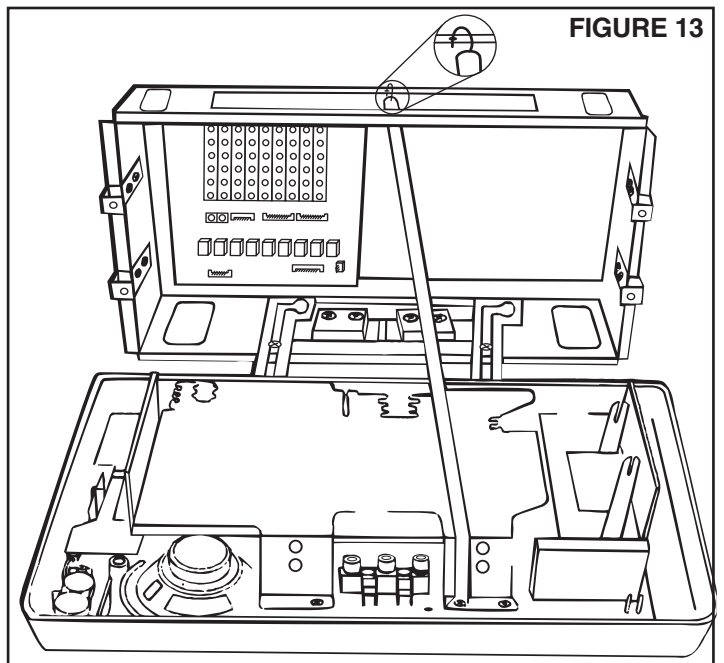

FIGURE 13

# INSTALLATION (Continued)

## CONNECTING THE POWER TRANSFORMERS

► CAUTION ◀

BE SURE THE AC POWER IS OFF BEFORE CONNECTING THE POWER TRANSFORMERS. DO NOT TURN AC POWER ON TO TRANSFORMERS UNTIL ALL WIRING AT THE REMOTE AND MASTER STATIONS IS COMPLETE!

1. Refer to Figure 14. The transformers' primary leads should already be connected to the 120 volt AC house supply wiring. Be sure power is off before connecting

**IMPORTANT WARNING!**

THE POWER TRANSFORMER CONTAINS AN INTERNAL FUSE.

**DO NOT SHORT THE LOW VOLTAGE CONNECTING SCREWS OF THE TRANSFORMER OR THE TRANSFORMER WILL BE DESTROYED!**

transformers to master unit.

2. Locate the two (2) sets of red/wht transformer leads on the lower left corner of the master unit. Connect one pair of low voltage leads to each transformer located in the bottom of the rough-in.

## MOUNTING THE TRANSFORMER COVER

**IMPORTANT:** The transformer cover must be installed for proper operation of the intercom.

1. Refer to Figure 15. Remove the left front and right rear screws from the transformer enclosure. Set screws aside for later installation.
2. Position the transformer cover (with insulator positioned towards transformers) over the transformer enclosure so holes in cover align with holes in enclosure.
3. Fasten cover with two (2) screws previously removed.

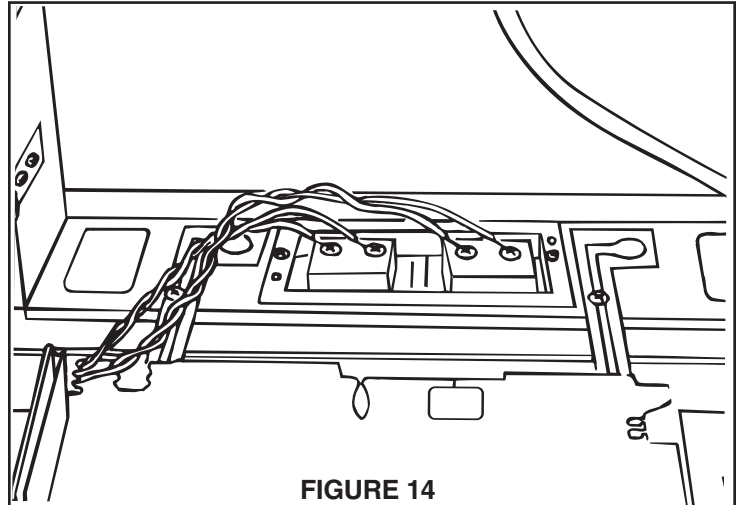

FIGURE 14

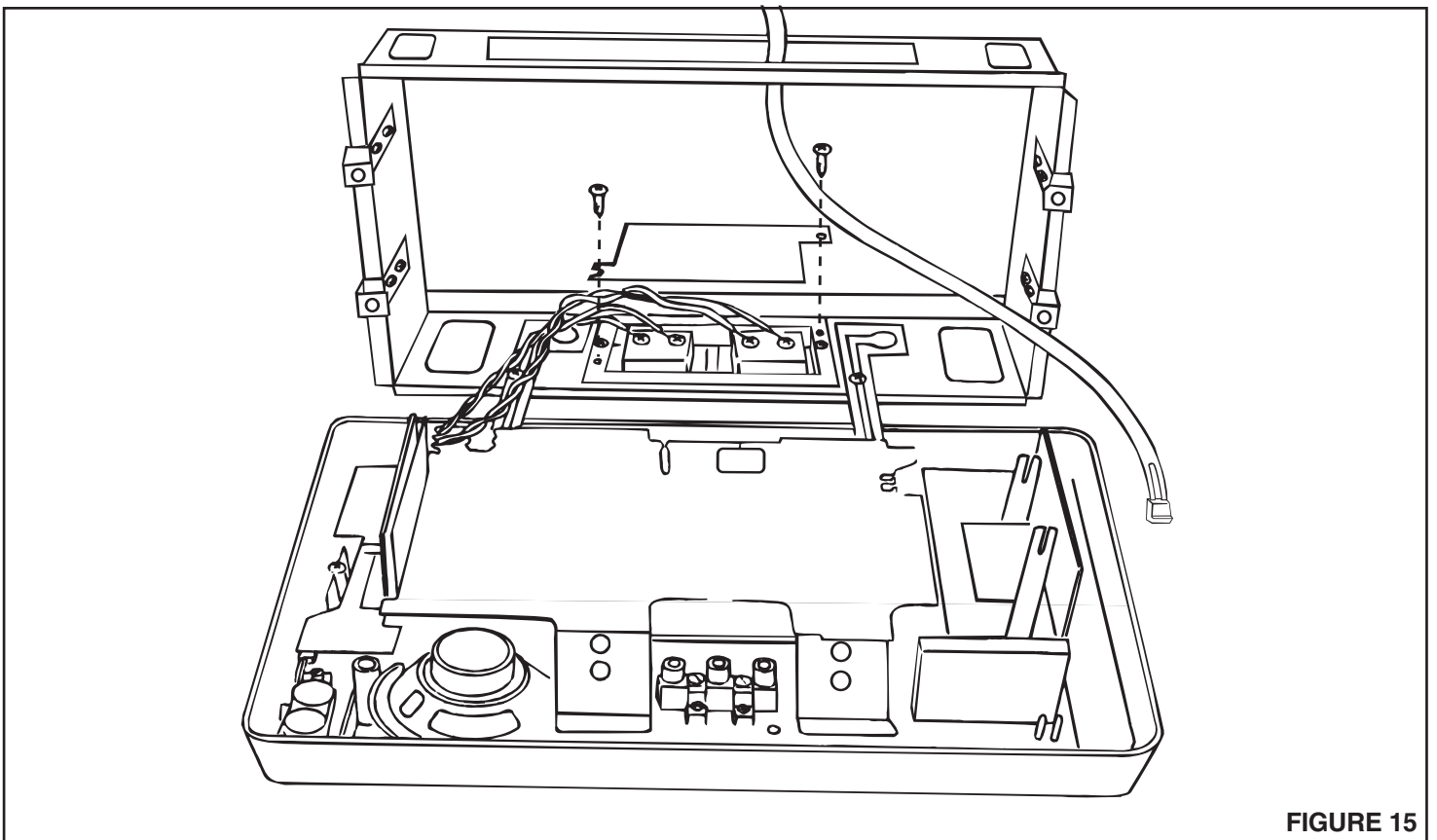

FIGURE 15

# INSTALLATION (Continued)

## CONNECTING THE MASTER STATION TO THE TERMINAL BOARD

1. Refer to Figures 16 and 17. Plug all five connectors into the terminal board.
  - Insert black ribbon cable with 10 pin plug into CN104 connector.
  - Insert multi-color ribbon cable with 14 pin plug into CN102 connector.
  - Insert multi-color ribbon cable with 9 pin plug into CN106 connector.
  - Insert brown shielded cable with 12 pin plug into CN101 connector.
  - Insert gray shielded cable with 11 pin plug into CN116 connector.
  - No connection is made to connector CN111 unless IAA-440 expansion module is used.
2. Make sure the alignment keys are properly aligned before applying pressure to the connector.
3. After all connectors are plugged into the terminal board, position the extra ribbon cable length toward the top of the rough-in frame.
4. If an IAA-440 expansion module is included in this installation, proceed with the connection of the module to the expansion module terminal board at this time. Refer to the installation instructions provided with the expansion module.

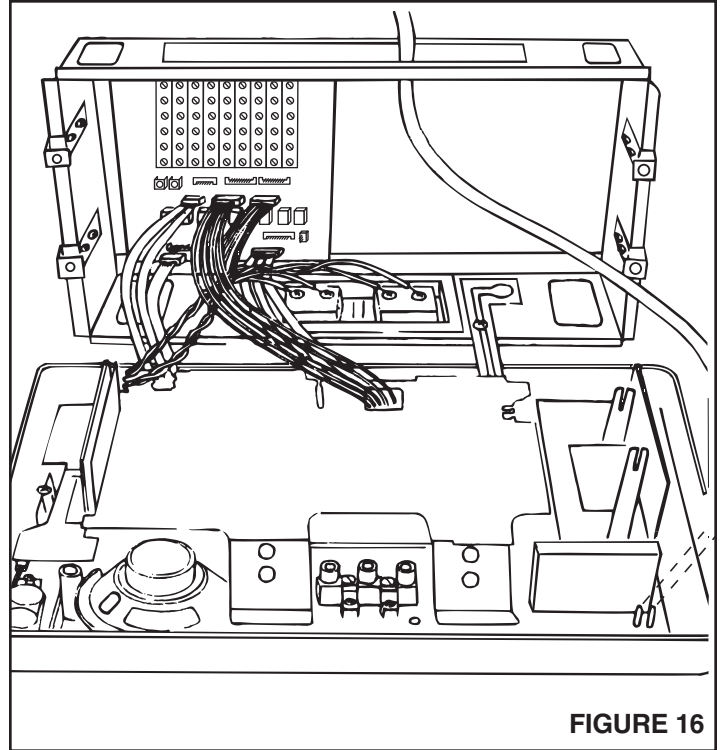

FIGURE 16

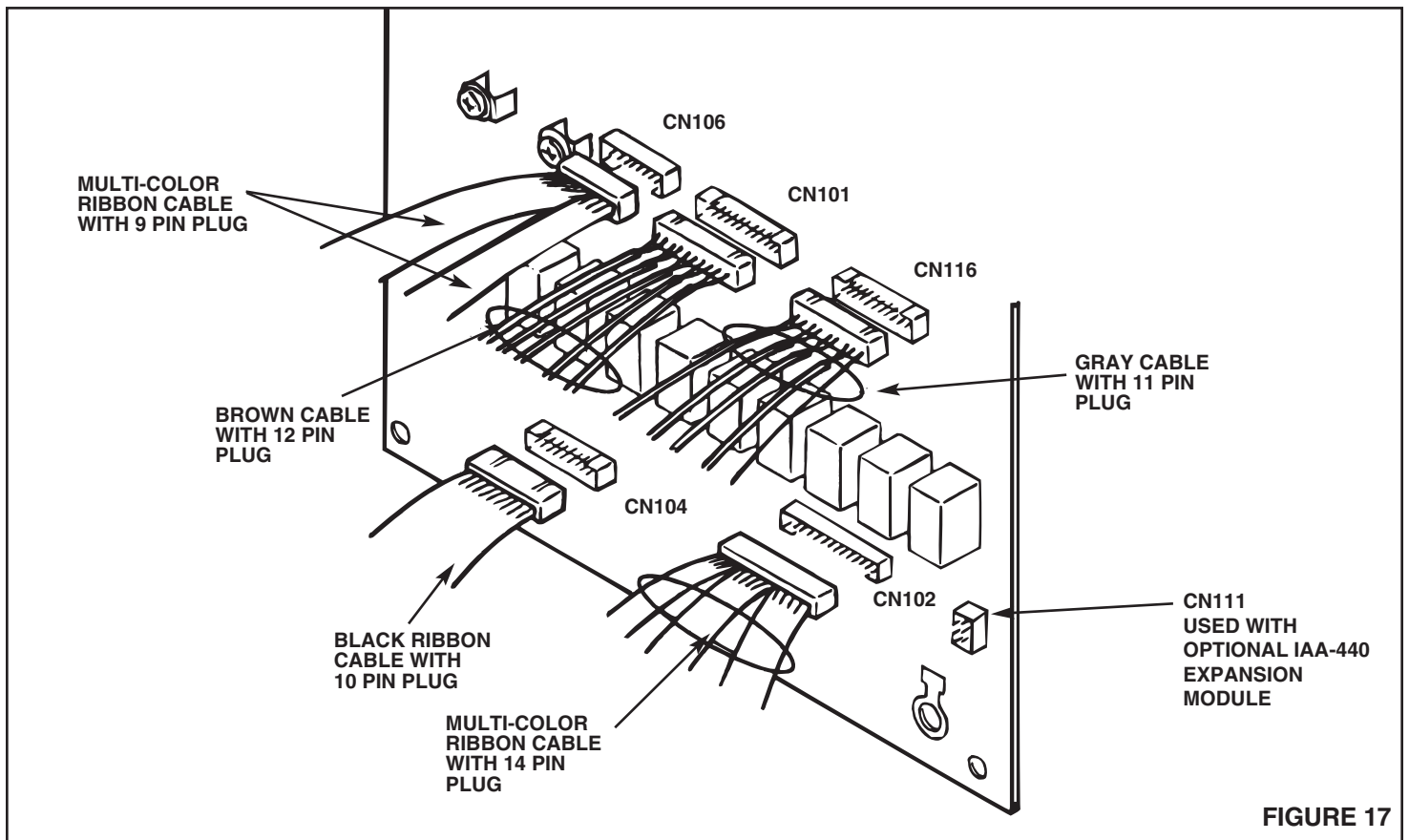

FIGURE 17



# INSTALLATION (Continued)

## CONNECTING THE RADIO ANTENNA

1. Refer to Figure 18. Plug radio antenna (supplied with IR105 rough-in frame) into the 2-pin connector located on the main circuit board. Be certain the tab on the connector is facing towards the top of the master unit, as illustrated.

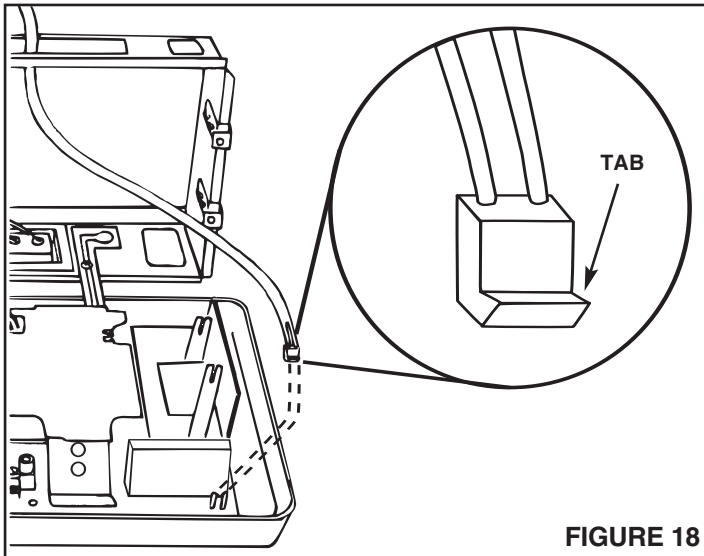

FIGURE 18

**NOTE:** Any excess antenna cable should be located outside of Rough-in.

In most locations the antenna supplied with the rough-in frame provides adequate AM reception; however, in rural or weak signal areas, a separate AM antenna may be required. Refer to the following instruction when selecting and connecting an AM antenna.

1. Refer to Figure 19. Move the auxiliary antenna selector switch to the AM position.
2. Connect 50 feet of 22 ga. insulated wire to the screw terminal marked **AM ANTENNA**.
3. Run the wire from the master station location to the attic. Fasten the insulated wire at one end of the attic; stretch the wire to its full length and fasten at the opposite end. Fasten the insulated wire at several locations between ends to prevent sagging.

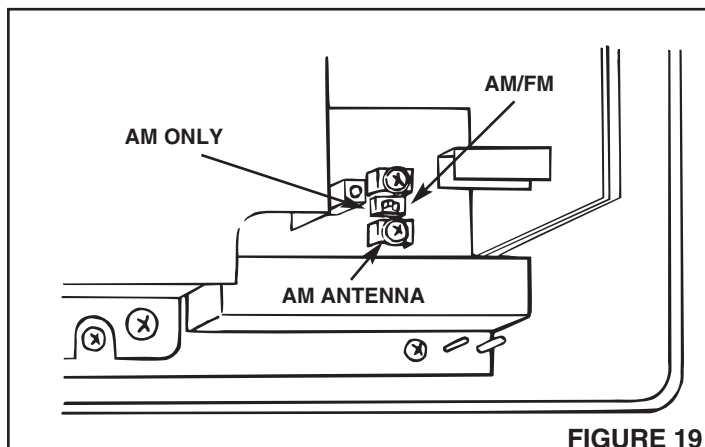

FIGURE 19

## CONNECTING THE OPTIONAL CHIME MODULE

It is now time to connect the optional chime module that you earlier installed into the master station.

1. Refer to Figure 20. Identify the front chime pushbutton wires.
2. Connect the front pushbutton wires to the screw terminals marked **FRONT** and **COMMON** on the chime module.
3. Repeat steps 1 and 2 for the **REAR** and **SIDE** chime pushbuttons.
4. Refer to the instructions packed with the chime module for information on chime volume level and chime tune selection (IA-29 only).

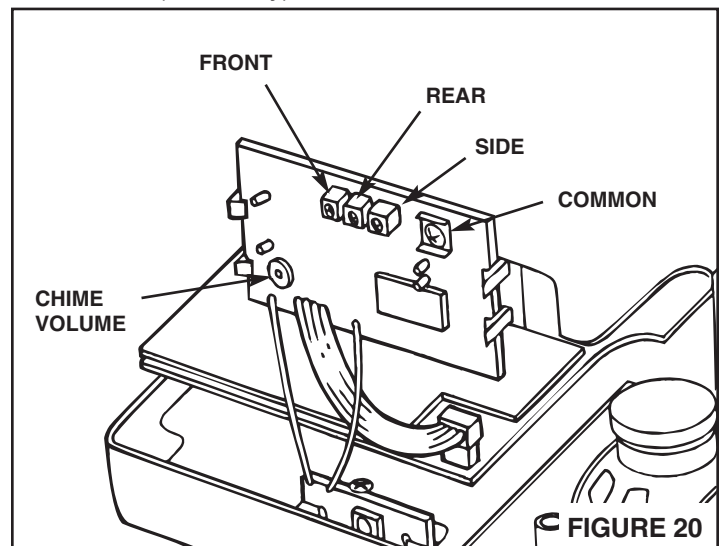

FIGURE 20

## CONNECTING OPTIONAL ELECTRONIC CHIME

1. Refer to Figure 21. Connect NuTone IW-2 cable from the chime to the (+) and (-) screw terminals on the master station's main circuit board.
2. Refer to the instructions packed with the chime for complete wiring information.

**IMPORTANT:** Failure to use NuTone IW-2 cable will cause the system to hum at all times.

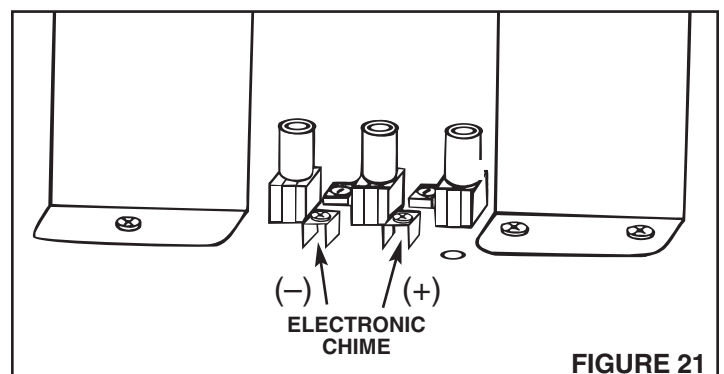

FIGURE 21

# INSTALLATION (Continued)

## CONNECTING OPTIONAL ACCESSORIES

1. Refer to **Figure 22**. To connect an external audio source (NuTone Model CP-95 cassette, stereo system, VCR, TV, etc. with low level audio output) to the IMA-4406 master station, locate the **TAPE** and **AUX** inputs on the upper center of the master station's main circuit board.
2. Connect an RCA™ phono type plug to the shielded audio cable coming from the external audio source. Follow the phono plug manufacturer's instructions when connecting to the cable.
3. Insert the phono plug into the appropriate input jack (**TAPE** or **AUX**) on the master station's main circuit board.  
**NOTE:** The **TAPE** and **AUX** inputs have input audio level controls to allow matching of the external audio source with the radio and CD audio of the master.
4. To use the selected source audio for recording onto a cassette recorder, insert the recorder's plug into the master station's **LINE OUT** jack.
5. Optional connection to provide program audio only:
  - The CD, radio or optional audio sources can be channeled through an auxiliary amplifier (purchase a NuTone Model IMA-516 separately) to provide uninterrupted music (no intercom) to separate speakers. This type of installation can be used for example, in a doctor's office where intercom and music are desired in the office area, but music only is desired in the waiting room.
  - **NOTE:** If an auxiliary amplifier is used, connect the master station's **LINE OUT** jacks to the auxiliary amplifier's low-level audio input wires using shielded audio cable (not supplied by NuTone).
  - **NOTE:** When using the **LINE OUT** for recording program audio or distributing program audio only through an external amplifier, the automatic **CD PAUSE** should be disabled or the audio present on the **LINE OUT** jack will stop when the intercom or chime is used. To disable the **CD PAUSE**, refer to the homeowner's manual.

## CONNECTING POWER TO THE OPTIONAL CP-95 CASSETTE PLAYER

1. Refer to **Figure 23**. Cut the protective sleeving from the end of the BLK/WHT CP-95 power supply leads.
2. Separate 2 inches of the supply leads.
3. Strip the outer insulation back approximately 5/8" from the end of the cable.
4. Connect the power leads from the CP-95 to the CP-95 power supply leads of the master station (polarity is not important). Use wire nuts to protect the bare wires from shorting.

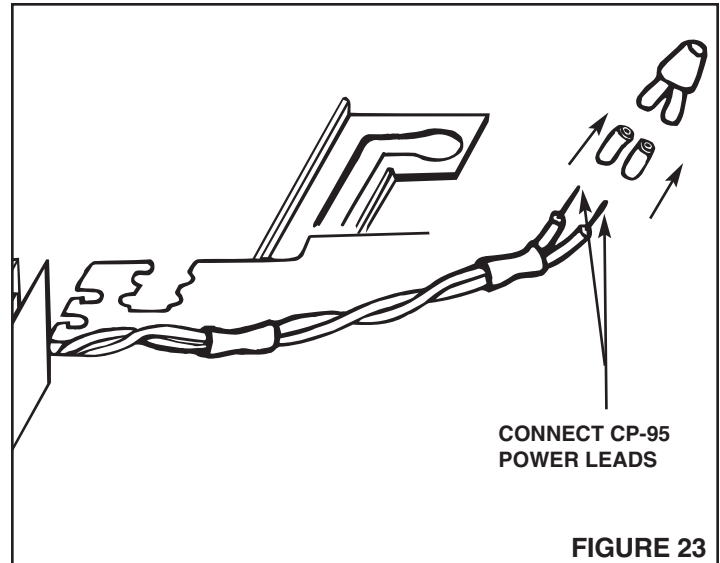

### ► IMPORTANT ◀

Be sure the power to the transformers in the IR-105 rough-in is **OFF** before connecting the CP-95 power supply leads!!

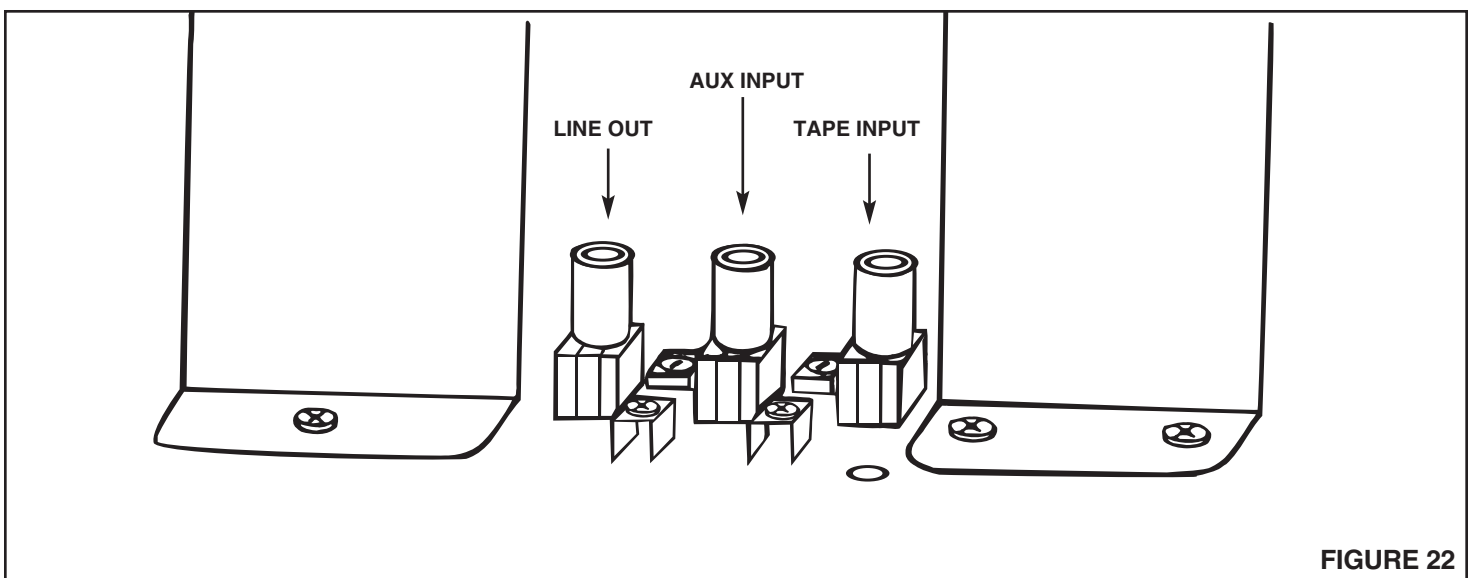

# INSTALLATION (Continued)

## MOUNTING AND CONNECTING OPTIONAL DOOR RELEASE PUSHBUTTON

You have previously prepared the master station for the optional release pushbutton.

1. Refer to Figure 24. Feed one wire from the door release transformer and one wire from the door release mechanism through the pushbutton hole in the master station panel.

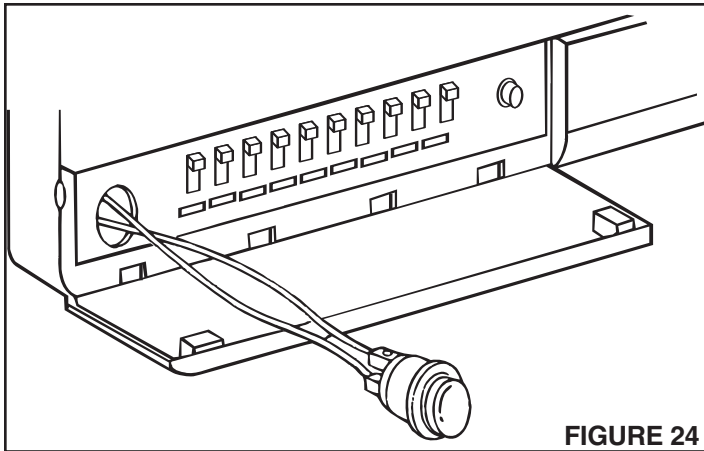

FIGURE 24

2. Connect the two (2) wires to the PB1WHCL pushbutton.
3. Rotate the pushbutton so the screws are on the top and bottom as illustrated, then snap the button into the mounting hole.

## CONNECTING THE MEMORY BACK UP BATTERY

Refer to Figure 25. Connect the 2-pin plug from the battery to the connector located on the control circuit board.

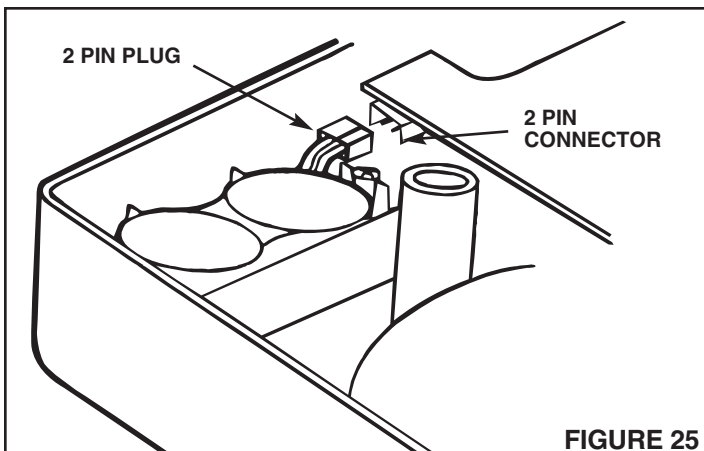

FIGURE 25

behind the mounting brackets. If the wall surface is hard, a

### PLEASE NOTE

If permanent AC power has not been connected, or the AC power will be off for long periods of time, the battery should not be connected at this time. When the battery is connected, the correct time and programmed radio memory stations will be retained for approximately 30 hours on battery backup.

clearance hole must be drilled behind the mounting bracket before securing the master station panel.

## POWERING UP THE SYSTEM

Once all connections have been completed throughout the system, it is time to apply power to the master station.

### CAUTION

WHEN RAISING THE MASTER PANEL TO ITS FINAL POSITION, DO IT SLOWLY! BE CAREFUL NOT TO HIT OR DAMAGE ANY OF THE CIRCUIT BOARDS OR CABLES.

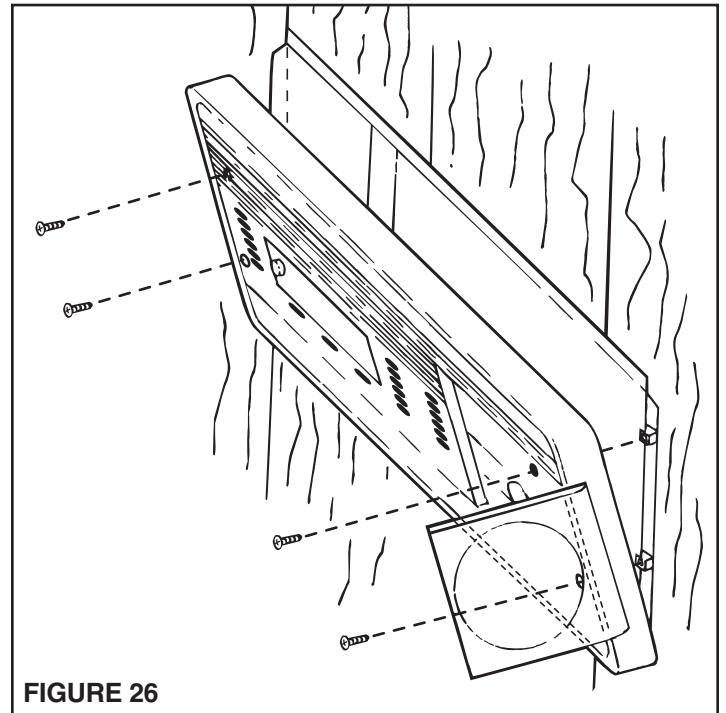

FIGURE 26

1. Apply power to the master station by turning on the circuit breaker that supplies power to the transformers in the IR-105 rough-in frame.
2. When power is first applied, the LCD display will flash 1:00 PM. Refer to the Operational Checkout section of this manual for additional information.

# OPERATIONAL CHECKOUT

## SYSTEM OPERATING CONTROLS

- ① **SCAN:** Activates scan tuning during AM/FM operation.
- ② **▲▼ UP/DOWN TUNING:** Provides manual tuning of the AM/FM radio.
- ③ **MEMORY 1-6 KEYS:** Provides direct access to stored radio frequencies.
- ④ **TRACK ◀:** Returns to the beginning of the current track and/or previous tracks.
- ⑤ **TRACK ▶:** Advances the CD Player to the beginning of the next track.
- ⑥ **RDM/RPT:** (Random/Repeat) Set the CD play mode to: REPEAT ONE, REPEAT ALL or RANDOM PLAY.
- ⑦ **PLAY/PAUSE:** Activates the operation of the CD Player. Pressing the key during play operation will pause the CD Player.
- ⑧ **SEARCH ▶:** Quickly searches the track in the forward direction.
- ⑨ **SEARCH ◀:** Quickly searches the track in the reverse direction.
- ⑩ **CD PLAYER DOOR:** Open CD door and snap CD disc onto spindle.
- ⑪ **TIME SET:** Used with the ▲ ▼ keys to set the clock and timer.
- ⑫ **MEMORY SET:** Stores desired radio frequencies into a selected memory location.
- ⑬ **CLOSE:** Press here to close CD Player door.
- ⑭ **TREBLE:** Adjusts the high frequency audio content of the source audio.
- ⑮ **STOP:** Ends the CD mode and turns off the program audio.
- ⑯ **BASS:** Adjusts the low frequency audio content of the source audio.
- ⑰ **SYSTEM VOLUME:** Adjusts the program audio level throughout the system.
- ⑱ **OPEN:** Causes the CD Player door to open.
- ⑲ **LOUDNESS:** Compensates for the bass and treble response the human ear has when listening to audio at low volume levels.
- ⑳ **MICROPROCESSOR RESET:** Initiates a reset of the microprocessor.  
**NOTE:** A reset of the microprocessor will erase the system's memory.
- ㉑ **DISPLAY:** Sets the LCD display mode: CLOCK, RADIO FREQUENCY, TRACK NUMBER or TIME PLAYED.
- ㉒ **INTERCOM VOLUME:** Adjusts intercom audio level throughout the system.
- ㉓ **MASTER STATION STATUS SWITCHES:** Sets the master station in one of the following modes: RADIO/INTERCOM, INTERCOM ONLY, OFF or MONITOR.
- ㉔ **REMOTE STATION STATUS SWITCHES:** Sets the remote stations in one of the following modes: RADIO/INTERCOM, INTERCOM ONLY, OFF or MONITOR. Note: If the optional expansion module is installed, 6 additional switches will be located on the right side of the master.
- ㉕ **DOOR RELEASE KNOCKOUT:** Mounting hole for optional door release pushbutton.
- ㉖ **END CALL:** Ends intercom communication and returns system to audio source.
- ㉗ **DOOR TALK:** Initiates intercom communication to the door speakers.
- ㉘ **INSIDE/PATIO:** Initiates intercom communication to remote stations.
- ㉙ **TIMER:** Enables or disables the radio timer. The indicator light will illuminate next to the Timer key when the Radio Timer is activated.
- ㉚ **PROGRAM AUDIO SOURCE:** Selects the program audio source: AM, FM, TAPE and AUX. The indicator light will illuminate next to the selected program audio source.
- ㉛ **ELECTRONIC CHIME TUNE SELECTION:** Selects the tune of the optional NuTone IA-29 Chime Module.
- ㉜ **PROGRAM OFF:** Turns off the selected program audio source. The program Off key does not affect the intercom or chime operation.
- ㉝ **MASTER VOLUME:** Adjusts the volume at the master station.

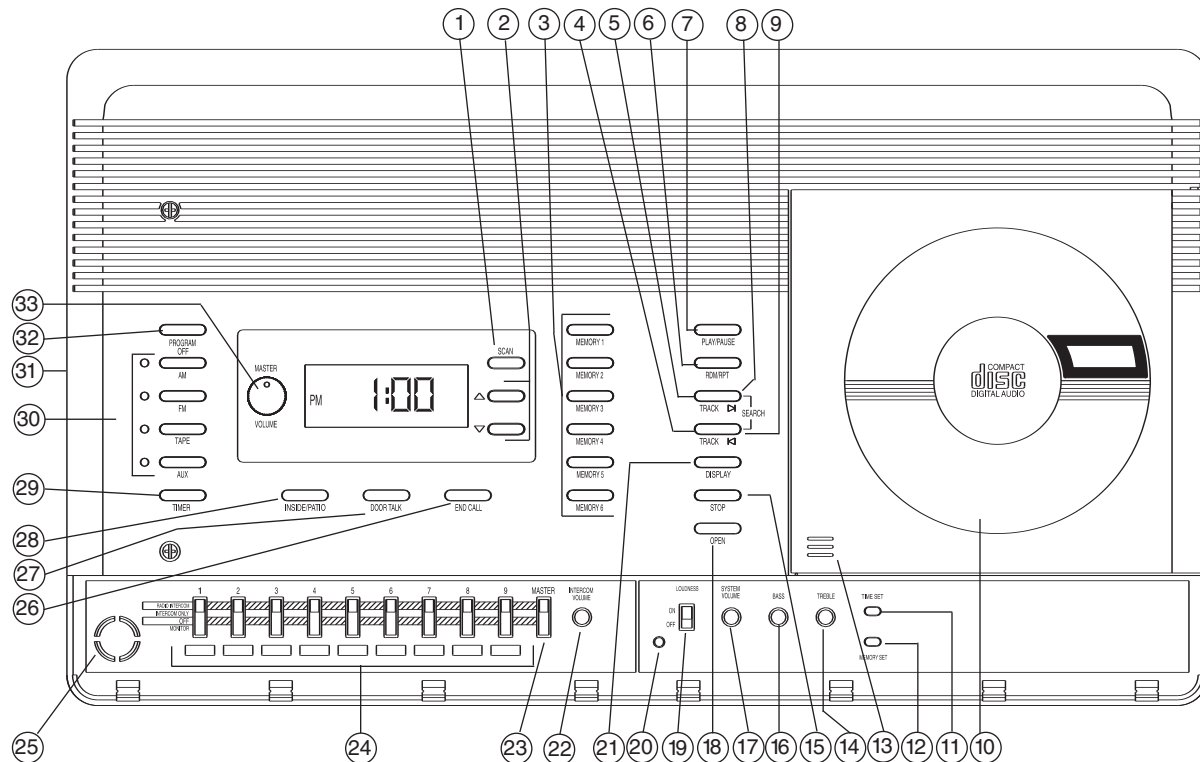

# OPERATIONAL CHECKOUT (Continued)

## DIGITAL CLOCK

### SETTING THE TIME

The proper clock setting procedure is arranged in 4 segments. Each segment must be completed in 5 seconds. Follow the procedure below.

1. Press the **TIME SET** key one time. The 'Hours' display will begin flashing, and the words 'Set Time' will display.
2. Within 5 seconds, press the ▲ or ▼ key until the correct Hour and AM/PM are displayed.
3. Within the next 5 seconds, press the **TIME SET** key again. The 'Minutes' display will begin flashing.
4. Again, within 5 seconds, press the ▲ and ▼ keys until the correct minute is displayed.
5. Release the keys after entering the correct time. The display will stop flashing in 5 seconds, and the time will be set.

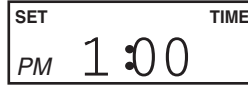

**NOTE:** Pressing the ▲ or ▼ keys momentarily will cause the time to advance or reverse one digit. Pressing the ▲ or ▼ keys continuously for more than 1/2 second will cause the digits to advance or reverse at high speed.

## SYSTEM CHECKOUT

Set the following control settings and perform the indicated tests.

1. Set all **STATION STATUS SWITCHES** to the **RADIO INTERCOM** position.
2. Set the **MASTER VOLUME** control to  $\frac{2}{3}$  position.
3. Set each remote station **VOLUME** control to  $\frac{2}{3}$  position.
4. Set the **SYSTEM VOLUME** control to  $\frac{1}{3}$  position.
5. Set the **INTERCOM VOLUME** control to  $\frac{2}{3}$  position.
6. Set the **BASS** and **TREBLE** control to  $\frac{1}{2}$  position.
7. Press the **OPEN** key on the master station. The CD Player door will open. Complete opening the door by moving the CD door from left to right.
8. Snap a CD disc onto the spindle of the CD player.

### ▶ CAUTION ◀

Never touch the lens of the CD player or damage will result!

9. Close the CD player door by moving the door from right to left until the door latches closed.
10. Tune in a strong local FM radio station as follows:
  - Press the FM key.
  - Locate a strong FM radio signal by using the ▲ ▼ keys.

Beginning with the master station, check each station in the system for proper operation using the following procedure.

1. Press the **INSIDE/PATIO** key to initiate a call. Radio audio will mute.
2. Release the **INSIDE/PATIO** key to hear the reply.

3. Press the **END CALL** key. Intercom communication will end and radio audio will return to all stations in the system.
4. Press the **DOOR TALK** key. Radio audio will mute and audio from the initiating station will be heard at the door speaker(s) and all stations in the system.
5. Release the **DOOR TALK** key. Audio from the door speaker(s) will be heard at all stations in the system.
6. Press the **END CALL** key. Door communications will end and radio audio will return to all stations in the system.
7. Press and hold the **END CALL** key for 2 seconds at any remote station. The radio will turn off.
8. Press and hold the **END CALL** key for 2 seconds at any remote station. The radio will turn on. For additional information on remote radio control, refer to the homeowner's manual.
9. With a CD in the CD player, press and hold the **END CALL** key at any remote station until a **BEEP BEEP** is heard at the remote station. In a few moments, the CD will begin playing.
10. Press and hold the **END CALL** key for 2 seconds at any remote station. The CD player and audio will stop. For additional information on remote CD Player control, refer to the homeowner's manual.
11. Repeat procedure at all remote stations.

## SETTING PROGRAM AUDIO CONTROLS

The volume levels required at each station may vary with the location of the speaker and the size of the room where the speaker is located. Spend some time experimenting with the volume levels, and adjust each speaker so that you can clearly hear the radio, CD and intercom. Use the following procedures to set your system's volume levels.

1. At each remote station, turn the **VOLUME** control completely clockwise to maximum volume.
2. At the master station, set the **REMOTE** and **MASTER SPEAKER STATUS SWITCHES** to the **RADIO INTERCOM** position.
3. Turn the **MASTER VOLUME** control to maximum volume.
4. Turn the **SYSTEM VOLUME** control on the master station to approximately  $\frac{1}{3}$  volume.
5. Select an AM or FM radio station with a strong, clear signal.
6. Adjust the master station's **SYSTEM VOLUME** control until you have ample volume at the remote station that requires the highest volume (i.e. a large living room, family room, basement, etc.)

**PLEASE NOTE:** The master station and all remote stations (except door speakers) are equipped with volume controls. Although the master station **SYSTEM VOLUME** sets the system's volume level, you may adjust an individual speaker's volume level as desired.

# OPERATIONAL CHECKOUT (Continued)

## SETTING PROGRAM AUDIO CONTROLS (CONTINUED)

7. Adjust the **MASTER VOLUME** control and all remote station's volume controls to the volume level you desire. In order to have proper intercom audio levels, it is recommended that the **MASTER VOLUME** and remote stations' **VOLUME** controls be set at  $\frac{2}{3}$  volume or higher.

## SETTING INTERCOM VOLUME

1. Initiate an intercom call from the master by pressing the **INSIDE/PATIO** key.
2. Speak with a clear normal voice about 2-3 feet from the master station's speaker.
3. Adjust the **INTERCOM VOLUME** control until the initiating station's audio is clearly heard at all stations in the system.

**PLEASE NOTE:** The volume control at all stations should be set between  $\frac{1}{2}$  to maximum volume for proper intercom operation.

4. Repeat the above procedure at several remote station locations until an acceptable intercom audio level is achieved at all stations.

## SETTING INTERNAL INTERCOM VOLUME CONTROL

The internal intercom volume control has been factory set for optimum intercom operation. Should the intercom gain need to be adjusted beyond the range of the Intercom Volume Control behind the left front door, use the following procedure:

1. **Refer to Figure 27.** Using a thin-blade screwdriver, adjust the internal control counter-clockwise as viewed from the rear of the master station panel. This adjustment will reduce the intercom gain.
2. To increase the intercom gain, turn the internal control clockwise.

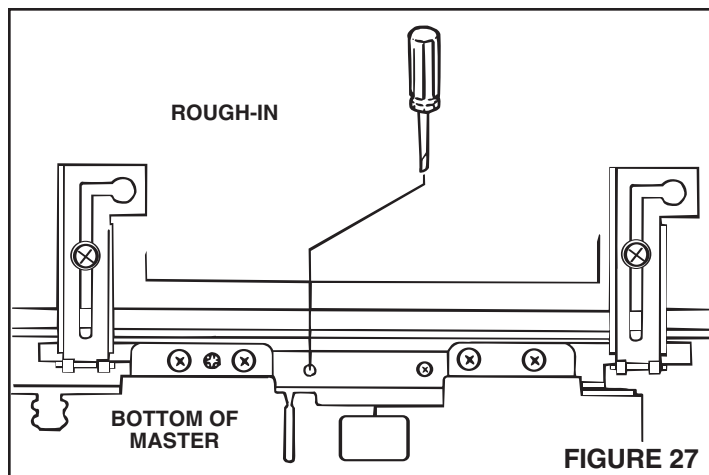

## SETTING THE BEEP TONE LEVEL

The internal **BEEP** tone volume control has been factory set to a normal level for the **BEEP** tone to be heard when the CD Player operation is initiated from a remote station by using the **AM/FM/CD CONTROL/END CALL** key. Should that level require adjustment, use the following procedure:

1. **Refer to Figure 28.** Using a thin-blade screwdriver, adjust the **BEEP TONE** volume control counter-clockwise as viewed from the rear of the master station panel to reduce the **BEEP** level.
2. To increase the **BEEP** level, turn the control clockwise.

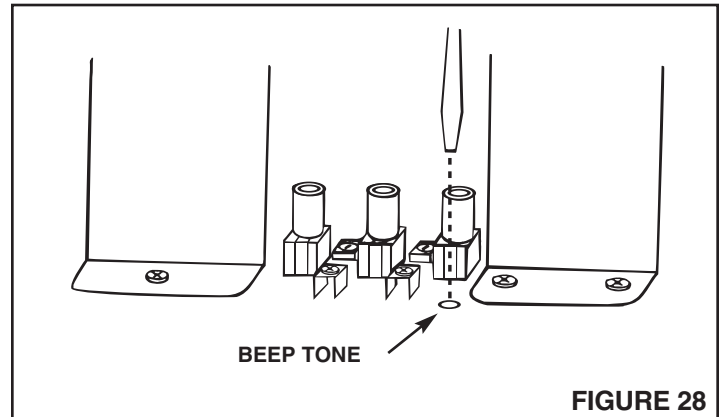

## SETTING THE EXTERNAL AUDIO SOURCE LEVEL

The **TAPE** and **AUX** level controls have been factory set at maximum. These controls can be adjusted to match the external audio source level with the built-in radio and CD Player levels. Use the following procedure:

1. Press the **FM** key.
2. Tune the radio to a strong local radio station.
3. Turn on the external audio source(s) connected to the master station.
4. Switch the master station from **FM** to **TAPE** or **AUX**.
5. **Refer to Figure 29.** Using a thin-blade screwdriver, adjust the **TAPE/AUX** control to match the audio level of the external audio source with the FM radio.

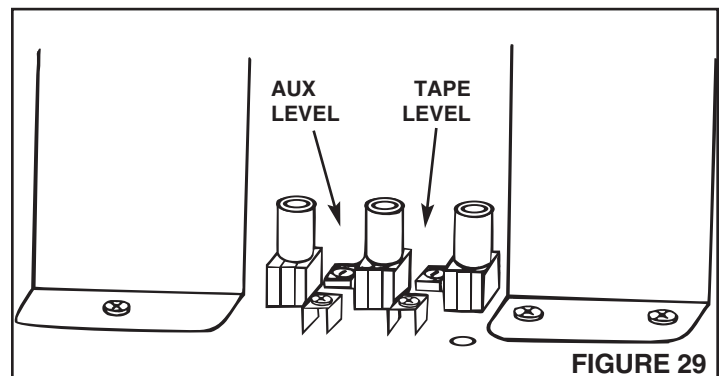

# OPERATIONAL CHECKOUT (Continued)

## DIAGNOSTIC TESTS

The following diagnostic tests have been incorporated into the NuTone IMA-4406 master station to assist in system troubleshooting.

- Master station keyboard test
- Remote station control voltage test
- Display test

The following applies to all diagnostic tests:

1. To access any of the diagnostic tests, the system must be in the **PROGRAM OFF** mode.
2. Pressing the **MEMORY SET** key will end the current diagnostic test.
3. The current diagnostic test will end after one minute of inactivity.

**PLEASE NOTE:** An incorrect voltage caused by miswiring, shorted wiring or a defective remote station may cause the radio and/or CD Player to turn off/on, thus preventing the unit from entering the diagnostic mode. Should this occur, the master station's control timer will stop the on/off cycling after 30 seconds.

**Remote Station Keyboard Test** – Verifies that all keys on the master station are functioning properly. To activate: Press and hold the following key in this order:

1. ▲ key
2. ▼ key
3. Memory 1 key
4. Release all keys

In this mode, the hours in the display represents the current diagnostic test and the minutes indicate the current key being pressed. The following will be displayed as the key is pressed.

KEY	DISPLAY	KEY	DISPLAY
No key	1:00	Memory 2	1:14
Scan	1:01	Memory 3	1:15
▲	1:02	Memory 4	1:16
▼	1:03	Memory 5	1:17
Program Off	1:04	Memory 6	1:18
AM	1:05	Play/Pause	1:19
FM	1:06	RDM/RPT	1:20
Tape	1:07	Track ►	1:21
Aux	1:08	Track ◀	1:22
Timer	1:09	Display	1:23
Inside/Patio	1:10	Stop	1:24
Door Talk	1:11	Time Set	1:25
End Call	1:12	Memory Set	1:26
Memory 1	1:13		

**Remote Station Control Voltage Test** – Displays the voltage at the master's microprocessor control line. To activate, press and hold the following keys:

1. ▲ key
2. ▼ key
3. Memory 2 key
4. Release all keys

**Example:**

Display	Voltage at Microprocessor
2:3.0	3.0 volts
2:1.9	1.9 volts
2:0.1	.1 volts

In this mode, the hours represent the diagnostic test, and the minutes indicate the voltage at the master station's microprocessor.

Mode	Voltage Window	
	Maximum	Minimum
End Call	.4 volts	0 volts
Inside/Patio	2.4 volts	1.6 volts
Door Talk	3.6 volts	2.8 volts
Quiescent	5.0 volts	4.3 volts

The control voltage windows for the three intercom modes and quiescent mode are listed above. For proper intercom operation, the control voltage produced when an intercom key is pressed at a remote station should fall between the voltage indicated.

**NOTE:** Pressing the **END CALL**, **DOOR TALK**, or **INSIDE/PATIO** keys at the master station will not change the voltage on the control line. If a remote station does not produce a voltage within the above window for a specific intercom function, check the following:

- Make sure all connections from the master station are properly installed at the terminal board.
- Check IW-6 connections at the master station terminal board and at each remote station.
- Confirm that the suspect remote station functions properly by replacing it with a known good remote station.

**Display Test** – Displays all segments in the LCD display. To activate, press and hold the following in this order:

1. ▲ key
2. ▼ key
3. Memory 3 key
4. Release all keys

## RESETTING THE MICROPROCESSOR

**NOTE:** Resetting the microprocessor will cause the radio memory channels and clock time to be lost.

Should the system not operate properly, the internal microprocessor may require resetting. To reset the microprocessor, use the point of a pen to press the reset button through the access hole behind the right lower door. See "System Operating Control" section.

# INSTALLER'S TROUBLESHOOTING GUIDE

TROUBLE	POSSIBLE CAUSE	POSSIBLE REMEDY
No radio, no intercom. (No Display).	No electrical power.	Be certain 120VAC, 60Hz power has been provided to the primaries of both 801T Transformers. No less than 16VAC should be measured on the secondary of either Transformer.
	Defective transformer.	Replace transformer.
No radio, intercom working. (AM/FM indicator on.)	Faulty Master Station.	Isolate Master Station from installation by removing ribbon cables from terminal board and wait one minute for timeout. With power on, radio should be playing at Master. If no radio, Master is probably faulty. If radio plays, reconnect ribbon cables.
	Installation problem.	Check terminal board for shorted terminals or miswired cables. Remove one 6-wire cable at a time to locate faulty line. When radio comes on, check speaker connections and run continuity check of speaker wiring.
	Antenna problem.	Check for shorted antenna connection. Remove antenna connector from tuner board and touch each pin with metallic object. If radio plays, antenna is not functioning; be sure it is installed properly. In weak signal areas, an outside antenna may be necessary. Also see "Connecting the Radio Antenna"
Low or distorted radio volume.	Incorrect volume setting.	Follow "Setting Program Audio Controls" instructions under OPERATIONAL CHECKOUT.
Weak and distorted music, chime and intercom audio.	Shorted or mis connected remote speaker wiring.	This unit contains a protection device which opens if the audio amplifier detects an overload condition. If the music, chime and intercom audio becomes weak and distorted, remove power from the master station for 10 minutes; this will reset the protective device. If the audio returns to normal, the remote speaker wiring and remote speakers should be checked for bare, shorted and/or mis-connected wires. The problem must be found and corrected before the master station will properly function.
Low or no intercom volume from remote speaker in MONITOR mode.	Improper operation.	Be sure remote speaker set for MONITOR has its volume control set between ½ and max, and receiving speakers have volume controls set between ½ and max. Follow "Setting Intercom Volume" instructions in OPERATIONAL CHECKOUT.
	Program and Intercom Volume Control adjustment.	Follow these instructions whenever the radio tends to overpower transmissions from a remote speaker in the MONITOR mode. These instructions will help you get the proper balance between the radio and the monitored speaker. <ol style="list-style-type: none"> <li>1. Set system volume control to midpoint.</li> <li>2. Set master to CD/TAPE or AUX position.</li> <li>3. Adjust volume control for each remote station and speaker in master station ¾ position.</li> <li>4. Set master to AM or FM and tune to a strong AM or FM station.</li> <li>5. Adjust program volume control for a desired listening level.</li> <li>6. Increase Intercom volume control setting. Adjust clockwise to desired monitor volume.</li> </ol>

-Continued-



# INSTALLER'S TROUBLESHOOTING GUIDE

TROUBLE	POSSIBLE CAUSE	POSSIBLE REMEDY
System squeals when using intercom.	Shorted wire on master or remote terminal board.	Check for short between terminals or loose wire.
	Two or more Remote Stations on same wire run to Master.	Make separate cable (IW-6) runs from each Remote Station to the Master.
	Speakers in adjacent rooms mounted on common wall, or mounted back to back.	If speakers are mounted directly back to back, one speaker will have to be relocated. If speakers are in a common wall, try placing fiberglass insulation behind each speaker, or isolate the speakers from the wall by placing rubber washers or weather stripping between speaker and wall.
	Improper wire used in installation.	NuTone Model IW-6 6-conductor twisted pair cable must be used.
Hum in speakers.	Intercom wiring run too close to household AC power wiring.	Keep intercom wiring as far as practical from household AC power wiring. Do not run intercom wiring parallel to AC power wiring.
	Shorted intercom power wiring or power wiring shorted to ground.	Check power connections to Master and connections to transformers.
	Interference from household electrical fixtures.	A dimmer may cause interference. For dimmer and fluorescent lighting interference, use filters (G.E. 89G635 or equivalent; NuTone Part No. 1559A-000).
Static.	Loose ground connection.	Check ground connection to Master and connection to earth ground source.
	Interference from household electrical fixtures.	A dimmer may cause interference. For dimmer and fluorescent lighting interference, use filters (G.E. 89G635 or equivalent; NuTone Part No. 1559A-000).
	Interference from household electrical appliances.	Correct interference at the source: fish tank, heater, hand tool, coffee pot, etc.
Remote Station not working.	Wire installation.	Check terminal board for broken wire or loose connection. Check continuity of wire.
	Speaker.	Check continuity of speaker. Clean switch controls. Substitute with speaker known to be in working order.
No door communication.	Wire installation.	Check continuity of wiring. Check connections at speaker and Master.
	Speaker.	Check with a speaker known to be in working order.
Optional Electronic Chime (Models IA-28 or IA-29) does not operate or operates at a low level.	Wire installation.	Be certain the chime is properly connected to the master station. Also, be certain the front, side and rear buttons are properly connected to the chime board.
	Improper volume setting.	Adjust the volume of the chime module by turning the volume potentiometer located on the chime module. NOTE: Chime Audio will NOT be heard at stations selected to the OFF or MONITOR.
Electronic chime can't be heard through the master station or remote speakers.	Improper volume setting.	Be certain the electronic chime is properly connected to the master station's electronic chime input screw terminals.
	Improper volume setting.	Adjust the volume of the electronic chime by turning volume potentiometer located on the chime.

-Continued-

# INSTALLER'S TROUBLESHOOTING GUIDE

TROUBLE	POSSIBLE CAUSE	POSSIBLE REMEDY
Cannot receive radio station which is received by another radio in home.	Faulty antenna connection.	Antenna should be located in attic and connected to tuner in Master. Check antenna connector to be sure it is connected to 2 pin connector on master.
IU is displayed continuously, and the radio cycles on/off continuously.	Shorted IW-6 wire going to remote station. Defective remote station.	Set remote station status switches one at a time to the OFF position. If IU stops at certain station, that stations wire or remote station is defective.
Low intercom volume.	Intercom volume control adjustment.	Increase intercom volume setting.
	Volume controls on remote stations set below ½.	Keep remote stations volume controls at ½ or higher for proper intercom operation.
	Internal intercom volume control.	Increase setting of internal intercom gain control.
When CD playback is started, it stops immediately or stops during playback.	Disc is badly scratched or warped.	Replace the disc.
	Disc is loaded with label facing inward.	Install CD with label facing outward.
	Improper data format (CD ROM)	Replace with conventional music format CD.
	Disc is dirty.	Clean disc if there are fingerprints or dirt on the disc. Wipe off with a soft cotton cloth. Wipe the disc from the center to the outside edge. Never use paint thinner, Benzene™ or conventional record cleaners.
With certain discs a loud pop is produced or play stops.	Disc has bad scratch or is warped.	Replace the disc.
	Disc is extremely dirty.	Clean disc if there are fingerprints or dirt on the disc. Wipe off with a soft cotton cloth. Wipe the disc from the center to the outside edge. Never use paint thinner, Benzene™ or conventional record cleaners.



# NuTone®

## Two Year Limited Warranty

**WARRANTY OWNER:** NuTone warrants to the original consumer purchaser of its products that such products will be free from defects in materials or workmanship for a period of two (2) years from the date of original purchase. **THERE ARE NO OTHER WARRANTIES, EXPRESS OR IMPLIED, INCLUDING, BUT NOT LIMITED TO, IMPLIED WARRANTIES OF MERCHANTABILITY OR FITNESS FOR A PARTICULAR PURPOSE.**

**During this two year period,** NuTone will, at its option, repair or replace, without charge, any product or part which is found to be defective under normal use and service. **THIS WARRANTY DOES NOT EXTEND TO FLUORESCENT LAMP STARTERS OR TUBES, FILTERS, DUCT, ROOF CAPS, WALL CAPS AND OTHER ACCESSORIES FOR DUCTING.** This warranty does not cover (a) normal maintenance and service or (b) any products or parts which have been subject to misuse, negligence, accident, improper maintenance or repair (other than by NuTone), faulty installation or installation contrary to recommended installation instructions.

The duration of any implied warranty is limited to the two year period as specified for the express warranty. Some states do not allow limitation on how long an implied warranty lasts, so the above limitation may not apply to you.

**NUTONE'S OBLIGATION TO REPAIR OR REPLACE, AT NUTONE'S OPTION, SHALL BE THE PURCHASER'S SOLE AND EXCLUSIVE REMEDY UNDER THIS WARRANTY. NUTONE SHALL NOT BE LIABLE FOR INCIDENTAL, CONSEQUENTIAL OR SPECIAL DAMAGES ARISING OUT OF OR IN CONNECTION WITH PRODUCT USE OR PERFORMANCE.** Some states do not allow the exclusion or limitation of incidental or consequential damages, so the above limitation or exclusion may not apply to you. This warranty gives you specific legal rights, and you may also have other rights, which vary from state to state. This warranty supersedes all prior warranties.

**WARRANTY SERVICE:** To qualify for warranty service, you must (a) notify NuTone at the address stated below or telephone 1/800-543-8687, (b) give the model number and part identification and (c) describe the nature of any defect in the product or part. At the time of requesting warranty service, you must present evidence of the original purchase date.

Date of Installation

Builder or Installer

Model No. and Product Description

#### IF YOU NEED ASSISTANCE OR SERVICE:

For the location of your nearest NuTone Independent Authorized Service Center:

**Residents of the contiguous United States** Dial Free 1-800-543-8687

Please be prepared to provide:

Product model number • Date and Proof of purchase • The nature of the difficulty

**Residents of Alaska or Hawaii should write to:** NuTone Inc. Attn: Department of National Field Service, 4820 Red Bank Road, Cincinnati Ohio 45227-1599.

**Residents of Canada should write to:** Broan-NuTone Canada, 1140 Tristar Drive, Mississauga, Ontario, Canada L5T 1H9.

Rev. 01/2005