

Owner's Manual

Applies to all
Ford OjO Electric
500 Series

OjO[®]
electric



THIS MANUAL CONTAINS IMPORTANT SAFETY, PERFORMANCE, AND MAINTENANCE INFORMATION. PLEASE READ AND UNDERSTAND THE MANUAL BEFORE TAKING YOUR FIRST RIDE AND KEEP THE MANUAL HANDY FOR FUTURE REFERENCE.

Note: Manual illustrations are for demonstration purposes only. Illustrations may not reflect exact appearance of actual product. Specifications subject to change without notice.

importer: OjO Electric, LLC
Address: 201 Lombard St.
Oxnard, CA 93030
USA

www.ojoelectric.com

MAN020 REV.2



Ford Motor Company trademarks and trade dress used under license to OjO Electric, LLC.



Welcome

WHAT'S INCLUDED IN THE BOX

- **OjO Electric Scooter**
- **Two (2) Key Fobs**
- **Four (4) Battery Removal Keys**
- **Owner's Manual**
- **Warranty Registration Card**
- **Seat Assembly Cover Plate**
(used when converting
to stand up only scooter)
- **One pair of rear view mirrors**

Product Serial Number

Important: Please record your unique serial number located on the back side of the front panel behind the clear plastic rectangular window. This serial number will be necessary for warranty coverage, future service, parts and accessory orders. Also, local law enforcement often requires this number should you suffer from theft or vandalism.

Product Serial Number: _____

**Congratulations on your OjO purchase
and welcome to the OjO family!**

OjO On...



The Rebirth of Transportation

The OjO was created with passion for the outdoors in mind. We've created a stylish, modern and eco-friendly way to travel. Weekend fun or a daily commute, you're now part of the revolution.

Own the bike lane.
Please read thoroughly and ride safely.



Table of Contents

| | |
|--|-------|
| Welcome/Registration _____ | 2 |
| Safety Warnings _____ | 5 |
| Before You Ride _____ | 5 |
| Learning To Ride/Disclaimers _____ | 6-8 |
| OjO Features _____ | 10-11 |
| Easy Quick Start Steps _____ | 12 |
| Comprehensive Overview _____ | 12-15 |
| Interactive Smart Touch Display _____ | 17 |
| Cleaning OjO/ Replacing Key Fob Battery, General Notes _____ | 18-19 |
| Removing Seat Assembly/Converting to stand up only scooter _____ | 20 |
| Troubleshooting _____ | 21 |
| Specifications _____ | 22 |
| Warranty Information _____ | 23-26 |
| Patents _____ | 26 |
| Glossary _____ | 26 |
| FCC Statement _____ | 27 |



Safety Warnings

Riding the OjO can be dangerous, even under ideal surface and weather conditions. Proper maintenance of your OjO is your responsibility and helps reduce the risk of injury. The OjO is designed to move and it is therefore possible to lose control and/or fall, resulting in serious injury or even death. Use the OjO only in accordance with the following instructions.

This manual contains important safety information. It is your responsibility to review this information and make sure that riders understand all warnings, cautions, instructions, and safety topics. OjO Electric, LLC recommends that all riders periodically review the information in this manual and that you regularly inspect and maintain your OjO to ensure safe operation for all riders.

The recommended OjO rider age of 16 and older is only an estimate and can be affected by the rider's size, weight, or skills. Any rider unable to fit comfortably on the OjO should not attempt to ride it. A parent's decision to allow his or her child to ride this product should be based on the child's maturity, skill, and ability to follow the rules and understand these instructions and warnings. Keep this product away from small children and remember that this product is intended for use only by persons who, even if age 16 or older are completely comfortable and competent while operating the product.

Riders should not exceed the OjO's weight limit of 300 pounds. A rider's weight does not necessarily mean that a person's size is appropriate to fit or maintain control of the OjO.

RIDING THE OJO IS ENTIRELY AT YOUR OWN RISK. USE COMMON SENSE AND GOOD JUDGMENT WHEN RIDING THE OJO.

PERSONS WITH ANY MENTAL OR PHYSICAL CONDITIONS THAT MAY MAKE THEM SUSCEPTIBLE TO INJURY OR IMPAIR THEIR PHYSICAL DEXTERITY OR MENTAL CAPABILITIES TO RECOGNIZE, UNDERSTAND, AND PERFORM ALL OF THE SAFETY INSTRUCTIONS AND TO BE ABLE TO ASSUME THE HAZARDS INHERENT IN UNIT USE.

Before You Ride

- Before each ride, inspect your OjO for abnormal wear and tear.
- Locate brake levers and check both front and rear for proper operation. Note: When brakes are activated, power to the motor is disengaged.
- Check for proper tire inflation. (see page 21).
- Make sure seat is properly adjusted and tightened.
- If music is desired, connect Bluetooth prior to the starting your ride.

Learning to Ride

For your first OjO ride, we recommend you go to an area free from cars, pedestrians, cyclists, and potential hazards to practice and familiarize yourself with the OjO controls and features. Place the OjO in “eco” mode when first learning how to operate.

Proper Riding Attire

Always wear proper protective equipment, including an approved safety helmet. Helmets may be required by local law. Follow the helmet manufacturer’s instructions for fit, use, and care of your helmet. OjO recommends wearing a long-sleeved shirt, long pants and gloves to minimize injury or scrapes in case of an accident. Wear athletic shoes with rubber soles (lace-up shoes should be tightly laced) and **DO NOT ride barefoot or in open-toed shoes**. Beware of pinching your fingers or getting them caught in moving parts when operating the OjO. Protective glasses are recommended.

Where to Ride

Your OjO is meant for bike lanes, boardwalks and other city paths in compliance with local laws. Always check and obey any local laws and regulations, which may affect the locations where the electric scooter may be used. Keep away from cars and motor vehicle traffic at all times. Only use the OjO where allowed. Debris, glass, sand or other items may cause instability or injury. You must have a clear view of the path ahead.

Safe Riding Practices and Warnings

- Ride defensively and always look ahead of where you’re going. Watch out for potential objects that could catch your OjO’s wheel or force you to swerve suddenly or lose control. Be careful to avoid vehicles, pedestrians, skaters, skateboards, scooters, bikes, children, or animals who may enter your path, and respect the rights and property of others.
- Do not weave through traffic or make any moves that may surprise others with whom you are sharing the road. Stay in the designated bike lane.
- Do not turn at excessive speeds or make sudden or sharp turns.
- Do not attempt or do stunts or tricks on your OjO. The OjO is not made to withstand abuse from misuse such as jumping, curb grinding, or any other type of stunts.
- Keep both hands on the handlebars and both feet on the footrest at all times.
- Never carry passengers on the OjO or allow more than one person at a time to ride the OjO.

- Keep your fingers and other body parts away from the brakes, wheels, and all other moving components.
 - Never use headphones or a cell phone when in motion on the OjO. The OjO's sound system should not be adjusted while in motion. Adjusting the OjO's sound system or remote controls via your device should only be done when the OjO is stopped and in a safe location away from other moving traffic or pedestrians.
 - Never ride the OjO while under the influence of alcohol or drugs.
 - Never hitch on to another vehicle or let yourself be pulled or pull anyone or anything while riding the OjO. Never try to tow anything.
 - Do not touch the motor, battery, or brakes on your OjO when in use or directly after use, as those parts can become very hot.
 - Do not ride the OjO in wet or icy weather and never immerse the OjO in water, as the electrical and ride components could be damaged by water or create other possibly unsafe conditions.
 - Do not activate the throttle unless you are on the OjO and in a safe, outdoor environment that is suitable for riding. The OjO is intended for use on solid, flat, clean, and dry surfaces such as pavement or level ground without loose debris such as rocks or gravel. Wet, muddy, icy, slick, or uneven and rough surfaces may impair traction and contribute to possible accidents. Do not ride the OjO in mud, ice, puddles, or water. Avoid excessive speeds that can be associated with downhill rides.
 - Do not ride the OjO when visibility is impaired.
 - Regularly check the OjO and its components. If any parts are broken or worn, do not ride the OjO until you have fixed or replaced the broken or worn parts.
- Persons with the following conditions should not operate the OjO: (1) heart conditions; (2) pregnant women; (3) persons with head, back, or neck ailments, or who have had prior surgeries to those areas of the body; and/or (4) persons with any mental or physical conditions that may make them susceptible to injury or impair their physical dexterity or mental capabilities to recognize, understand, and perform all of the safety instructions and to be able to assume the hazards inherent in the use of the OjO.
- Do not make any alterations or modifications to the OjO, or add any parts not authorized by OjO Electric, LLC. Do not remove any reflectors, lights, or other standard equipment.

WARNING: LIMITATION OF LIABILITY USE OF THIS PRODUCT IS ENTIRELY AT YOUR OWN RISK. USE ONLY AS DIRECTED. FAILURE TO HEED THE WARNINGS LISTED ABOVE INCREASES THE RISK OF POTENTIALLY SERIOUS INJURY. USE THE APPROPRIATE CAUTION WHEN RIDING AND ALWAYS WEAR SAFETY EQUIPMENT. OJO ELECTRIC, LLC SHALL NOT BE RESPONSIBLE FOR ANY DAMAGE, LOSS, OR INJURY OF ANY KIND, INCLUDING DIRECT OR INDIRECT DAMAGES, CONSEQUENTIAL DAMAGES, PERSONAL INJURIES, DAMAGES TO PROPERTY, OR DEATH RESULTING FROM THE USE OR MISUSE OF THIS PRODUCT.

Charging

Fully charging requires 5-6 hours for primary battery and 8-10 hours for double battery. Time necessary to fully charge will depend on initial battery power when beginning the charge. Keep display power on and OjO will enter into charging mode. When battery is charging the last grid of Battery capacity symbol will be flashing. When battery is fully charged the grid will no longer flash. When charging your OjO, observe best practices and precautions.

- The charger supplied with the OjO should be regularly examined for damage to the cord, plug, enclosure, and other parts, and in the event of such damage, the product must not be charged until the charger has been repaired or replaced.
- The power switch for the OjO should always be turned to "off" when charging except when you want to check the battery capacity. Do not use the OjO or any features on the OjO while it is charging. The motor will be inoperable while battery is charging.
- Use caution when charging the OjO's battery.
- The OjO's battery charger is not a toy. The charger should be operated by an adult.
- Do not operate the OjO's battery charger near flammable materials or any flame, such as a furnace, a fireplace, water heaters, or space heaters.
- Unplug the charger and disconnect it from the OjO when not in use.
- Always disconnect the charger prior to wiping down and cleaning your OjO with liquid.



**Required California Disclosures
(Cal. Vehicle Code § 407.5)**

**YOUR INSURANCE POLICIES MAY NOT PROVIDE
COVERAGE FOR ACCIDENTS INVOLVING THE USE
OF THIS SCOOTER. TO DETERMINE IF COVERAGE
IS PERMITTED, YOU SHOULD CONTACT YOUR
INSURANCE COMPANY OR AGENT.**

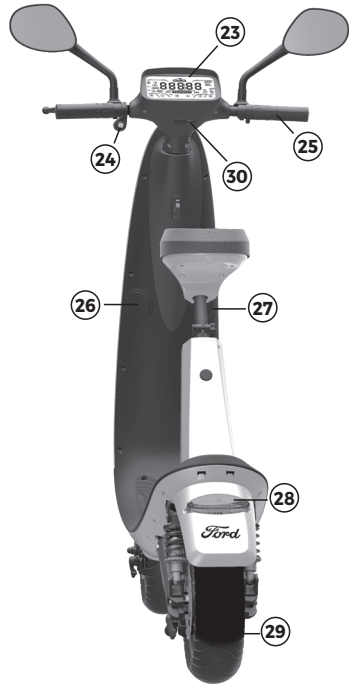
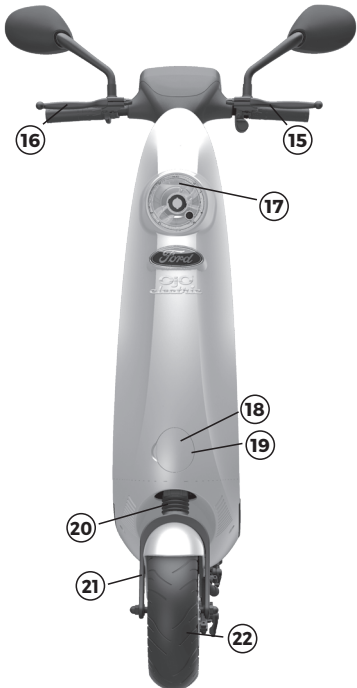

OJO FEATURES

- 1.** Convenient Storage Hook
- 2.** Serial Number
- 3.** Patented Ergonomic Design
- 4.** Quick-Release Seat Height Adjustment
- 5.** Patented Removable Seat System
- 6.** Rear Shocks
- 7.** Patented HyperGear[®] Hub Motor
- 8.** Rear Disc Brake
- 9.** Rear Brake Caliper
- 10.** Solid Aluminum Swing Arm
- 11.** Kickstand
- 12.** Front Brake Caliper
- 13.** Front Disc Brake
- 14.** Air Vents
- 15.** Front Brake Lever
- 16.** Rear Brake Lever
- 17.** Headlight
- 18.** Patented Hidden On-Board Charger
- 19.** Hinge Door For Patented Retractable Cord & Plug
- 20.** Front Mono Shock
- 21.** Solid Aluminum Forks
- 22.** High-Performance Pneumatic Front Tire
- 23.** Capacitive Touch Screen Display
- 24.** Horn Button
- 25.** Twist Throttle
- 26.** Left Bluetooth Speaker
- 27.** Right Bluetooth Speaker
- 28.** Rear LED Light
- 29.** High-Performance Pneumatic Rear Tire
- 30.** USB port for phone charging

Easy Quick Start Steps

- 1. Turn On** - Activate OjO by pressing power button **ON/OFF**
- 2. Pick a speed** - Your OjO has three speed modes eco [>], touring [>>], sport [>>>]. Once turned on, the OjO is preset to eco mode. On display, press (+) once to access touring mode and press (+) twice to access sport mode. To reduce speed press (-) accordingly.
- 3. Gently Apply Throttle** - Your OjO is equipped with a pressure sensitive twist throttle. With both hands firmly gripping the handlebars gently twist throttle toward you with your right hand to accelerate. - To stop pull brake levers towards you.
- 4. Turn Off** - To turn off OjO press the power button **ON/OFF**

Comprehensive Overview

Battery - Removable primary battery with optional secondary battery for extended range which can be purchased through your OjO Dealer.

NOTE: Do not install or remove secondary battery when your OjO is ON or charging as this may cause a system fault where battery capacity on display is not accurate.

Charging your OjO battery: Your OjO Electric Scooter is factory equipped with a best in class lithium-ion battery.

- Before riding for the first time, be certain to charge the battery for a full 8 hours. Time necessary to fully charge will depend on initial battery power when beginning the charge. When battery is charging the last grid of Battery capacity symbol will be flashing. When battery is fully charged the grid will no longer flash.
- It's best to begin your first ride of the day with a full charge.
- The OjO is equipped with a 110v plug that is compatible with most North American households. The door with a magnetic lock allows access to patented retractable cord and plug. Pull retractable cord to desired length, then plug into a standard 110v wall outlet. To unplug give a slight tug and retract cord gently. Do NOT let go of the plug until it is fully returned to home position. Close protective housing door.
- DO NOT use any battery other than one provided by OjO. However, you may interchange OjO batteries between compatible OjO products.
- Charge the battery in a dry, well-ventilated area. Keep away from high temperature or fire, keep the scooter dry to avoid damage to the charger.



Maintenance/Care

- NEVER allow the charger or cord to come in contact with water as this may cause an electric shock. DO NOT touch with wet hands.
- NEVER allow the battery to get wet.
- Never allow the charger cord to come in contact with anything sharp or hot.
- Perform periodic visual inspections of the battery and charging cord. If there is any obvious damage found with the charging cord or the battery itself, DO NOT use the charger or the scooter. Visit our website at www.ojoelectric.com or call us **Toll Free at 1 877 557 1053**.
- For battery storage: Remove the battery pack and store it in a climate controlled area.
- **Failure to recharge battery every two months may result in a battery that will not accept a charge.**



Battery Removal

- The OjO primary battery pack is simple to access and remove when necessary.
- DO NOT attempt any type of battery work or removal near a water source or with wet hands.
- Locate the OjO battery cover on the deck which is kept in place with a single key lock.

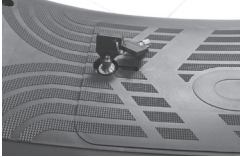

1. Use Key to unlock and remove plastic battery cover.



2. Remove Battery Plate



3. Lift battery taking care to not damage the connector plug contacts.

To reinstall battery, reverse above procedure.

Rear View Mirror Installation



1. Install the mirror into the threaded hole in the base of the brake lever.



2. Rotate the mirror until the mirror is in the desired position. Screw and tighten the jam nut on the mirror with a wrench



3. Adjust the mirror for best rear view visibility.

Brakes

Your OjO is equipped with two disc brakes for maximum reliability and effectiveness. Applying hand pressure to the right brake lever causes the rear brake to engage, applying hand pressure to the left brake lever causes the front brake to engage. Once you have eased off the throttle, pull the brake levers towards you to slow down and stop.

WARNING:
STOPPING DISTANCES WILL VARY DEPENDING ON THE SPEED, WEIGHT OF RIDER, TERRAIN AND SURFACE CONDITIONS.

⚠ The brake is capable of skidding the rear tire and throwing an unsuspecting rider. Practice in an open area free from obstacles until you are familiar with the brake function. Avoid skidding to a stop as this can cause you to lose control and/or damage the rear tire.

Adjusting the Brakes

Periodically your OjO brakes may need adjusting. To adjust the brake cable tension, loosen the adjuster finger lock nut (A). Rotate the brake barrel (B) in or out until the desired brake adjustment is attained, then tighten finger lock nut. See Diagram

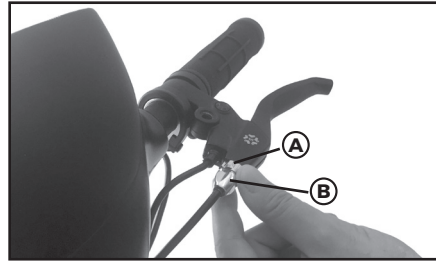

Brake Pad

Due to normal wear, your OjO brake pads may need to be periodically replaced. These brake pads are available at OjOelectric.com or your authorized OjO dealer.

Charger

Unique to the OjO is the built in retractable charger cord. Simply open the door with a magnetic lock to access to patented retractable cord and plug, pull retractable cord to desired length, then plug into standard 110v wall outlet. To remove, unplug and with a slight tug, retract cord gently. Do NOT let go of the plug until it is fully returned to home position. Close protective door.

Charging

Fully charging requires 5-6 hours for primary battery and 8-10 hours for double battery. Time necessary to fully charge will depend on initial battery power when beginning the charge. Keep display power on and OjO will enter into charging mode. When battery is charging the last grid of Battery capacity symbol will be flashing. When battery is fully charged the grid will no longer flash.

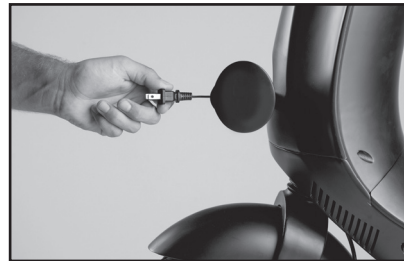

Display

The OjO is equipped with an interactive touch screen with capacitive technology that allows you to control the OjO once it has been turned on. By using the display, the operator can adjust speed modes, turn the headlight/tail light on or off, link your smart phone with Bluetooth speakers, adjust the volume, speed modes, and view battery level, trip time, trip distance and odometer. **NOTE:** Avoid letting the touch screen come in contact with water as it could affect the operation.

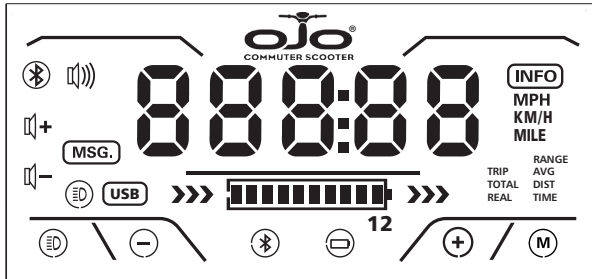

- M Mode** Pressing the "M" (Mode) symbol allows the user to change between Current speed, Average speed, Trip distance, Total distance, Trip time.

Access the Setting Menu to switch on/off voice commands by holding **M** (Mode) 2 seconds. Press the **+** or **-** button to change the On/Off voice prompt, and then press **M** button for 2 seconds to store the changed setting.

- + - Speed** Your OjO has three speed modes: eco [**>**], touring [**>>**], sport [**>>>**]. Once turned on, the OjO is preset to eco mode. On display, press (**+**) once to access touring mode and press (**+**) twice to access sport mode. To reduce speed press (**-**) accordingly.
- Light** **Headlight/Taillight** To turn the lights on and off, press the light symbol located on the bottom left corner of the display. The light symbol on bottom left will light up when light is on and will turn off when light is off.

Adjusting Backlight Brightness

Press **Light** button to turn on the headlight, the display shows the headlight symbol, at the same time, the backlight brightness will reduce by 50%. Press **Light** again to switch off the headlight, the backlight will return to the highest brightness.

- Bluetooth Connection** The Bluetooth button located bottom center of the display allows you to connect the OjO to a cellular device. Before connecting, check that Bluetooth is activated on your smart-phone. Press the symbol and another Bluetooth symbol will appear on the top left of the display. When the Bluetooth symbol is flashing, the OjO is ready to sync to your smart-phone. Once connected, OjO will announce, "Bluetooth connected". Change volume at any time, and change song at any time by hold-touch **+** or **-** two seconds.

 **Battery Level** The display includes a bar meter which indicates battery level. Ten bars indicates a full charge. When battery outline is flashing, battery needs to be recharged.

 **Primary/Secondary Battery Switch** Switches charge status on screen between primary and secondary batteries. "1" indicates primary battery, "2" indicates secondary battery, if installed. When OjO is in charging mode, touching this button will illuminate the display to check battery capacity. After the OjO finishes charging (and unplugged) or in sleep mode, touch the Primary Secondary Battery Switch to activate display into normal mode (exit charging/sleep mode).

 **Speaker Volume** To adjust speaker volume, press - or + key on display. Hold for rapid volume increase and decrease. While Bluetooth is on, The volume can be adjusted to 0-100 with 100 being maximum volume and 0 no sound. The volume adjustment will exit after 3 seconds of no operation.

NOTE: Volume will default to whatever the volume was when last used.

 **USB Port for charging phone**
A convenient USB port for phone charging is located just under the display. See page 10 number 30.



Error Codes

If a malfunction occurs, an error code will be appear on the display. Please refer to this chart for description of error code.



| Error Code | Meaning | Solution |
|------------|-------------------------------|---|
| 21 | Current Abnormality | Have the controller checked |
| 22 | Throttle Abnormality | Have the throttle checked |
| 23 | Motor Abnormality | Have the motor checked |
| 24 | Motor Hall Signal Abnormality | Have the connection and contacts between the motor and controller checked |
| 25 | Brake Abnormality | Have the brake checked |
| 30 | Communication Abnormality | Have the connection and contacts between the controller and the Display checked |

Horn

The yellow horn button on the OjO can be found on the left side of the handlebars.

Key Fob

Included is a wireless key fob which is necessary for turning OjO on and off as well as arming and disarming motion activated alarm for theft deterrence.

- A. Press ON/OFF button once to turn OjO on.
- B. Press ON/OFF button once to turn OjO off.
- C. Press (lock button)  once to arm alarm.
- D. Press (unlock button)  once to disarm alarm.



Replacing Key Fob Battery

Remove case back using a small coin or equivalent. Using small screw driver or similar device, push battery from battery edge so that it slides out from beneath the battery hold down bracket. **DO NOT ATTEMPT TO REMOVE THE BATTERY HOLD-DOWN BRACKET.** Slide in new battery (CR 1632). Snap Key fob case back together.

Kickstand

Make sure kickstand is in the up position prior to riding the OjO. Do not sit on your OjO with the kickstand in the down position. Make sure the OjO is stable before stepping off.

Lights

Your OjO is equipped with state of the art front headlight and rear LED lights. The headlight and taillight is controlled by the light icon on the display. The brake light illuminates when the brakes are applied whether lights are on or off.

Cleaning OjO

A quality automotive soap works best in removing dirt and grime. Avoid brushes and abrasive scrub pads as they may scratch the finish. Use a soft sponge or hand towel to wash the body panels. **AVOID** using high pressure washers as they may damage wiring harnesses. A battery pack should **NEVER** be pressure washed. If you live close to an ocean, avoid prolonged exposure to ocean spray or salt water. If either comes in contact with your OjO, wipe down immediately.

Motor

The Patented 500kw HyperGear® Motor is completely sealed and requires no maintenance or lubrication. Keep free of sand and other debris. Do not ride or submerge in standing water.

Seat

Your OjO seat height is adjustable. Ensure that both feet can easily touch the ground when setting height. Important: Make sure seat height is set and the seat clamp is tight before riding the OjO. The OjO scooter is designed for a single rider only.



Converting to a stand up only scooter

Some riders may prefer to remove the entire seat assembly for standing, and a more versatile riding experience.

How to remove seat post assembly:



1. Release seat clamp and remove seat and post.



2. Remove four Allen screws that are located at the base of the seat tower.



3. Slide up and remove plastic seat tower cover.

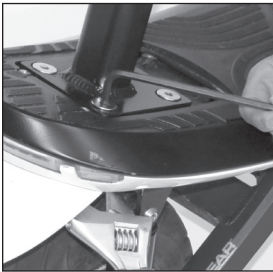

4. Remove four Allen head bolts and lock nuts (tools not included). To perform this operation you will need a six millimeter Allen wrench and a 17 millimeter open end or crescent wrench.

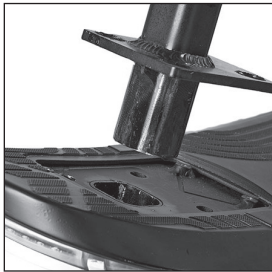

5. Remove seat tower.



6. Install seat cover plate (included in carton) using the four Allen screws removed in step number two above.

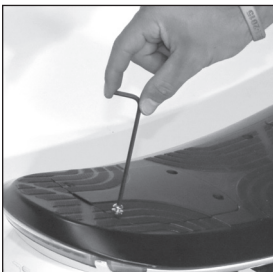

7. Keep all removed seat components in a safe place for future use.



Speakers/Bluetooth

Dual bluetooth speakers are integrated into the OjO and are tuned for your enjoyment. Volume can be controlled on the display. Do NOT wear headphones while riding the OjO.

Storage

The OjO should be stored in a clean dry space. Extreme moisture and dampness should be avoided. Remove the battery pack and store it in a climate controlled area. **Note: Failure to recharge battery every two months may result in a battery that will not accept a charge.**

Suspension

Your OjO is equipped with full front and rear suspension. It is NOT intended for off road use. Jumping, wheelies, and stunt riding is not recommended and can result in injury or death. While it is designed to be maintenance free, periodic inspection is necessary.

Twist Throttle - See Page 12

To accelerate, using your right hand gently twist the throttle (located on the right side of handlebars) towards you. To decelerate, simply release pressure from the twist throttle.

Tires

Routinely inspect tires for excessive wear and cracks in the sidewall. Replace tires when necessary. The front and rear tires on the OjO have a recommended pressure of 22 PSI. Replacement tires are available at ojoelectric.com or at your authorized OjO dealer.

WARNING: Over or Under inflation may seriously affect safety and rideability.

WARNING: RIDING ON EXCESSIVELY WORN OR DAMAGED TIRES CAN AFFECT THE MANEUVERABILITY AND STOPPING OF YOUR OjO, WHICH COULD RESULT IN SERIOUS INJURY OR EVEN DEATH.

TROUBLESHOOTING

OjO won't turn on

Make sure OjO battery has a charge (See "Charging your OjO battery" page #12);
Make sure battery is properly connected (See "Battery Removal" page #14);
Make sure key fob battery is good. (See "Replacing key fob battery" page #19)

OjO won't charge

Check the display to make sure the display has entered into charge interface and the battery capacity grid is flashing. If the display has entered into charge interface and the battery capacity grid is no longer flashing, the battery is fully charged.

Make sure GFI/breaker on power outlet is on. Make sure battery is properly connected. (See "Battery Removal" page 14)

OjO steering is heavy

Check tire pressure is between 16 and 22 PSI. Low tire pressure causes difficult steering and reduced maneuverability.

Loss of acceleration

Battery may be within last 20% of capacity. (See Charging page #12) or, brake lever is held while throttle is applied. Must release brake lever.

Need Help?

Visit our website at www.ojoelectric.com or call us **Toll Free at 1 877 557 1053.**

Specifications

| | |
|-------------------------------|--|
| Top Speed | 20 mph (32.2 kph) |
| Range | 25 miles (40.2 km) |
| Riding Modes | >Eco Mode (beginner orientation) |
| | >>Touring Mode (distance maximizing) |
| | >>>Sport Mode (peak performance) |
| Battery (Primary) | |
| Specs | Removable Lithium-Ion Battery Pack |
| | 48VDC at Max Charge |
| | Battery Life Cycles 600 |
| | 100-240V, 13AH |
| Key Fob Battery | |
| | Lithium Replacement Battery #CR1632 |
| Charger | |
| | Patented 100-240VAC; 3.0A 50/60 Hz On-Board Charger with retractable Cord & Plug |
| Motor | |
| Motor Type | Patented Brushless HyperGear® Hub Motor |
| Climbing Performance | Up to 15% Grade |
| Structural | |
| Frame | Welded Monocoque Aluminum Frame |
| Suspension | Mono Front Shock and Dual Rear Shocks |
| Brakes | High Performance Mechanical Disc Brakes |
| Wheel Rim | Aluminum |
| Tires | 4P-R Load Range Pneumatic Tubeless Tire |
| Curb Weight | 77 lbs. (35kg) |
| Ground Clearance | 6.5 inches (165.1mm) |
| Maximum Wt Capacity | 300 lbs. |
| Wheelbase | 45 inches (1143 mm) |
| Overall Length | 54 inches |
| Overall Height | 49.5 inches |
| Width (handlebars) | 23 inches |
| Hook - Max Load | 5 lbs. |
| Display | |
| Screen Material | STN |
| Bluetooth frequency band | 2402MHz-2480MHz |
| Bluetooth max output power | 8.2dBm |
| Accessories/Software versions | OjO500 V1.0 |
| User Interface | |
| Infrared Touch Screen Display | The touchscreen controls speed modes, rear & front lights, music, provides information on trip time, mileage, battery level, and other riding related information. |
| Wireless Control | Key Fob |
| Security | Motion-Activated Alarm |
| Headlight | Incandescent Light |
| Rear Light | LED |
| Bluetooth Speakers | Dual Waterproof Speakers for Dynamic Enhanced Audio |
| Phone Charging | USB PORT |
| Emissions | ZERO |

Warranty Information

OjO Electric, LLC, provides the following limited product and performance warranties (the "Warranty") to each OjO ("Scooter") owner when purchased directly from OjO Electric, LLC, or an authorized retailer, that the Scooter is complete and the functional parts will be free of defects for the periods and under the terms indicated below.

Warranty Period

- This Warranty begins on the first day you, as a retail purchaser, take possession, or register your Scooter (whichever is earlier). The Warranty period is for two (2) years.
- Parts repaired or replaced under this Warranty are covered only until the Warranty period ends, or as otherwise provided by applicable law. (The Warranty cannot be transferred to another owner or scooter)
- In order to obtain Warranty service, call 1-877- 557-1053, or take your Scooter (at your discretion) to an authorized OjO retailer/ service center. An OjO Service Technician will determine if you have an issue that is covered by the Warranty. Go to **ojoelectric.com** for further information. We request that you have your OjO Scooter serviced at an OjO Service Center. If you decide to maintain it yourself, or have it maintained/ serviced by an independent repair facility, we require that you use genuine OjO parts. Be aware, however, that service performed independently from OjO may result in the voidance of the Warranty Maintenance Exclusion.

Regular maintenance is not included with your OjO purchase. These expenses are the customer's responsibility.

Genuine OjO Replacement Parts

Warranty repairs are to be performed by OjO service centers who use only genuine OjO parts.

Covered Items

The Warranty covers the repair or replacement, at OjO's option, of any part that is defective in material or factory workmanship under normal use for the applicable Warranty period. Regular required maintenance or replacement of expendable maintenance items are not covered by the Warranty.

Battery Warranty

- The batteries on the OjO Scooter are warranted for two (2) years. The terms of this battery warranty are set forth in this Section.
- If your battery requires Warranty service, OjO Electric, LLC will (at its sole discretion) repair the battery, or replace it with a factory-reconditioned battery that has an energy capacity equal to, or better than, that of the original battery when the failure occurred. This is based on a prorated basis. Due to the battery chemistry, there is a normal, expected reduction in range/capacity that battery packs can yield over time and usage. Depending on use and storage conditions, battery capacity (and resultant range) will diminish during the duration of this Warranty period.

What your Scooter and Battery Warranties do not Cover

The following are not included as part of the Warranty:

- Official OjO Accessories, tires and brake pads
- The cost of parts and labor involved in any routine care and maintenance and/or the replacement of parts due to normal wear and tear, use, or deterioration, including but not limited to: tires, brake pads and rotors, grips and the seat seating surfaces.
- Any cosmetic concerns that arise as a result of accidents, environmental conditions (including acid rain, volcanic ash, sea salt, bird droppings, hail and/or UV exposure), owner misuse, overloading, use as a tow vehicle, lack of routine care and maintenance, and/or other improper use.
- Damage, malfunctions, or performance problems caused by after-market accessories installed on a OjO scooter by someone other than an authorized OjO service center.
- Damage, malfunctions, or performance problems caused by any modification of the Scooter or the improper repair or installation of any parts not sold or approved by OjO Electric, LLC.
- Damage, malfunctions, or performance problems caused by fire, collision, accident, or improper storage.

Customer responsibilities

As the owner of a Scooter covered by this Warranty, it is your responsibility to read, understand and comply with the Owner's Manual, this Warranty, and all product warnings before operating your OjO Scooter. Serious injury or death can result from improper operation or failure to observe warnings and safety instructions on any OjO scooter.

Voiding the warranty

- The Warranty will be voided with avoidable, continued operation of the OjO Scooter after an error code appears indicating a mechanical or operational problem.
- OjO Scooters severely damaged or declared to be a total loss will not be covered under this Warranty.
- Exposing the Scooter or battery to ambient temperatures above 120°F (49°C) or below -22°F (-30°C) for more than 24 hours at a time will void the Warranty.
- Subjecting the OjO Scooter to flood water, windstorms, hailstorms or other similar occurrences will void the Warranty.
- Immersion of the OjO Scooter in any liquid medium will void the Warranty.
- Attempting to alter the programming of any OjO electronic system will void the Warranty.

Warranty Voidance Specific to the Batteries

In addition to the actions set forth above which will void the Warranty, the battery warranty will be voided in the event the following actions occur:

- Damage resulting from intentional abuse, a collision or accident, or opening of the battery case will void the Warranty.
- Exposing the battery to direct flame or the immersion of the battery in any liquid medium will void the Warranty.
- Dropping the battery onto hard surfaces, sufficient to crack the outer casing will void the Warranty. If you drop the battery and the outer casing does not crack, you should contact OjO to have the battery inspected.

Disclaimers

THIS WARRANTY DOES NOT COVER NORMAL WEAR AND TEAR, SHIPPING DAMAGE, UNAUTHORIZED ALTERATIONS, MODIFICATIONS, ACCIDENTAL DAMAGE AND DAMAGE FROM MISUSE OR NEGLIGENCE. EXCEPT AS OTHERWISE PROVIDED BY APPLICABLE LAW AND THE LIMITED PRODUCT AND PERFORMANCE WARRANTIES INCLUDED ABOVE, THE FOREGOING REMEDIES STATE OJO ELECTRIC, LLC'S SOLE AND EXCLUSIVE OBLIGATION AND CUSTOMER'S SOLE AND EXCLUSIVE REMEDY FOR A BREACH OF THE FOREGOING LIMITED WARRANTIES. THE LIMITED WARRANTIES SET FORTH HEREIN ARE IN LIEU OF AND EXCLUDE ALL OTHER EXPRESS OR IMPLIED WARRANTIES, INCLUDING BUT NOT LIMITED TO WARRANTIES OF MERCHANTABILITY AND FITNESS FOR A PARTICULAR PURPOSE OR APPLICATION AND ALL OTHER WARRANTIES OR OBLIGATIONS ON THE PART OF OJO ELECTRIC, LLC. SOME JURISDICTIONS LIMIT OR PROHIBIT DISCLAIMERS OF WARRANTY, SO THE ABOVE DISCLAIMER MAY NOT APPLY TO THE EXTENT SUCH LIMITATIONS OR PROHIBITIONS APPLY.

Limitation of Liability

TO THE MAXIMUM EXTENT PERMITTED BY APPLICABLE LAW, OJO ELECTRIC, LLC HEREBY DISCLAIMS, AND SHALL HAVE NO RESPONSIBILITY OR LIABILITY WHATSOEVER FOR, DAMAGE OR INJURY TO PERSONS OR PROPERTY OR FOR OTHER LOSS OR INJURY RESULTING FROM ANY CAUSE WHATSOEVER ARISING OUT OF OR RELATED TO THE SCOOTER OR ANY OF OJO ELECTRIC, LLC'S OTHER PRODUCTS OR THEIR USE. TO THE MAXIMUM EXTENT PERMITTED BY APPLICABLE LAW, UNDER NO CIRCUMSTANCES SHALL OJO ELECTRIC, LLC BE LIABLE TO CUSTOMER, OR TO ANY THIRD PARTY CLAIMING THROUGH OR UNDER CUSTOMER, FOR ANY LOST PROFITS, LOSS OF USE, OR EQUIPMENT DOWNTIME, OR FOR ANY INCIDENTAL, CONSEQUENTIAL OR SPECIAL DAMAGES OF ANY KIND, HOWSOEVER ARISING, RELATED TO THE OJO OR ANY OF OJO ELECTRIC, LLC'S OTHER PRODUCTS, EVEN IF OJO ELECTRIC, LLC HAS BEEN ADVISED OF THE POSSIBILITY OF SUCH DAMAGES. TO THE MAXIMUM EXTENT PERMITTED BY APPLICABLE LAW, OJO ELECTRIC LLC'S AGGREGATE LIABILITY, IF ANY, IN DAMAGES OR OTHERWISE, SHALL NOT EXCEED THE PURCHASE PRICE PAID TO OJO ELECTRIC, LLC BY CUSTOMER FOR THE SCOOTER AND OTHER PRODUCTS. CUSTOMER ACKNOWLEDGES THAT THE FOREGOING LIMITATIONS ON LIABILITY ARE AN ESSENTIAL ELEMENT OF THE AGREEMENT BETWEEN THE PARTIES AND THAT IN THE ABSENCE OF SUCH LIMITATIONS THE PURCHASE PRICE OF THE OJO AND OTHER PRODUCTS WOULD BE SUBSTANTIALLY DIFFERENT. SOME JURISDICTIONS LIMIT OR DO NOT PERMIT DISCLAIMERS OF LIABILITY, SO THIS PROVISION MAY NOT APPLY. SOME JURISDICTIONS MAY LIMIT OR PROHIBIT THE LIMITATION OR EXCLUSION OF DAMAGES, SO THE ABOVE LIMITATIONS OR EXCLUSIONS MAY NOT APPLY TO THE EXTENT SUCH LIMITATIONS OR PROHIBITIONS APPLY.

Governing Law and Arbitration

This Warranty shall be interpreted under, and governed by, the laws of the State of California, without regard to the conflict of laws principles. Either OJO ELECTRIC, LLC or Customer may elect to have any dispute, claim or controversy arising out of or related to the Scooter or use of the Scooter or arising out of or related to this Warranty, including any alleged breach hereof, or any matter governed by this Warranty (collectively, a "Dispute") resolved through binding arbitration by providing prompt written notice of such election to the other. Upon such election, all such Disputes will be settled exclusively by arbitration with a single arbitrator in accordance with the Commercial Arbitration Rules of the American Arbitration Association (the "Rules"). The arbitration hearing shall take place in Santa Monica, CA. Judgment upon the award rendered by the arbitrator may be entered in any

court having jurisdiction thereof. The arbitrator will have the power to render equitable relief as well as monetary damages but shall not have the power to award consequential, punitive, exemplary damages or any other form of relief precluded under the provisions of this Warranty. The arbitrator will have the power to award reasonable fees and expenses in accordance with the Rules.

CUSTOMER UNDERSTANDS AND AGREES THAT, IF EITHER CUSTOMER OR OJO ELECTRIC, LLC ELECTS TO ARBITRATE A DISPUTE OR CLAIM, THIS ARBITRATION SECTION PRECLUDES CUSTOMER AND OJO ELECTRIC, LLC FROM HAVING A RIGHT OR OPPORTUNITY TO LITIGATE DISPUTES OR CLAIMS THROUGH A COURT, TO BRING A CLAIM AS A PURPORTED CLASS ACTION, OR TO PARTICIPATE OR BE REPRESENTED IN LITIGATION FILED IN COURT BY OTHERS. ALL DISPUTES AND CLAIMS MUST BE RESOLVED AS AN INDIVIDUAL ACTION, NOT AS A CLASS ACTION, THROUGH ARBITRATION IF CUSTOMER OR OJO ELECTRIC, LLC TO ARBITRATE.

Subject to the arbitration provisions above, Customer irrevocably submits to the jurisdiction of the Courts of the State of California and the United States District Court of Western Division of California in any Dispute, and hereby irrevocably agrees that all claims in respect of such Dispute may be heard and determined in such state or federal court. Customer agrees that regardless of any statute of law to the contrary, any claim or cause of action Customer may have that arises out of or is related to this Warranty, the OJO or to OJO ELECTRIC, LLC must be filed within one (1) year after such claim or cause of action arose. If Customer fails to timely file such claim or cause of action, Customer shall be forever barred from bringing such claim or action against OJO ELECTRIC, LLC.

Patent Pending and Trademark Notifications

- Patented HyperGear™ Rear Hub Motor
- Patent Pending Ergonomic Geometric Design
- Patent Pending On-Board Charger with Retractable Cord and Plug
- Patent Pending Removable Seat Assembly

Glossary

| | |
|---------------------------|----|
| Battery _____ | 12 |
| Brakes _____ | 15 |
| Charger _____ | 15 |
| Display _____ | 17 |
| Horn _____ | 18 |
| Key Fob _____ | 18 |
| Kickstand _____ | 19 |
| Lights _____ | 19 |
| Cleaning _____ | 19 |
| Motor _____ | 19 |
| Seat _____ | 19 |
| Speakers/ Bluetooth _____ | 21 |
| Storage _____ | 21 |
| Suspension _____ | 21 |
| Throttle _____ | 21 |
| Tires _____ | 21 |

This device complies with Part 15 of the FCC Rules. Operation is subject to the following two conditions:

- (1) This device may not cause harmful interference, and
- (2) This device must accept any interference received, including interference that may cause undesired operation.

Cet appareil est conforme à la section 15 des réglementations de la FCC. Le fonctionnement de

l'appareil est sujet aux deux conditions suivantes :

- (1) cet appareil ne doit pas provoquer d'interférences néfastes, et
- (2) cet appareil doit tolérer les interférences reçues, y compris celles qui risquent de provoquer un fonctionnement indésirable.

Note: This product has been tested and found to comply with the limits for a Class B digital device, pursuant to Part 15 of the FCC Rules. These limits are designed to provide reasonable protection against harmful interference in a residential installation. This product generates, uses, and can radiate radio frequency energy and, if not installed and used in accordance with the instructions, may cause harmful interference to radio communications. However, there is no guarantee that interference will not occur in a particular installation. If this product does cause harmful interference to radio or television reception, which can be determined by turning the equipment off and on, the user is encouraged to try to correct the interference by one or more of the following measures:

- Reorient or relocate the receiving antenna.
- Increase the separation between the equipment and receiver.
- Connect the equipment into an outlet on a circuit different from that to which the receiver is connected.
- Consult the dealer or an experienced radio/TV technician for help.

FCC Radiation Exposure Statement:

This equipment complies with FCC radiation exposure limits set forth for an uncontrolled environment. This transmitter must not be co-located or operating in conjunction with any other antenna or transmitter.

Please take attention that changes or modification not expressly approved by the party responsible for compliance could void the user's authority to operate the equipment.

This device complies with Industry Canada licence-exempt RSS standard(s).

Operation is subject to the following two conditions:

- (1) this device may not cause interference, and
- (2) this device must accept any interference that may cause undesired operation of the device.

Le présent appareil est conforme aux CNR d'Industrie Canada applicables aux appareils radioexempts de licence. L'exploitation est autorisée aux deux conditions suivantes :

- (1) l'appareil ne doit pas produire de brouillage, et
- (2) l'utilisateur de l'appareil doit accepter tout brouillage radioélectrique subi, même si le brouillage est susceptible d'en compromettre le fonctionnement.

Under Industry Canada regulations, this radio transmitter may only operate using an antenna of a type and maximum (or lesser) gain approved for the transmitter by Industry Canada. To reduce potential radio interference to other users, the antenna type and its gain should be so chosen that the equivalent isotropically radiated power (e.i.r.p.) is not more than that necessary for successful communication.

Conformément à la réglementation d'Industrie Canada, le présent émetteur radio peut fonctionner avec une antenne d'un type et d'un gain maximal (ou inférieur) approuvé pour l'émetteur par Industrie Canada. Dans le but de réduire les risques de brouillage radioélectrique à l'intention des autres utilisateurs, il faut choisir le type d'antenne et son gain de sorte que la puissance isotrope rayonnée équivalente (p.i.r.e.) ne dépasse pas l'intensité nécessaire à l'établissement d'une communication satisfaisante.

OJO[®]
electric



Santa Monica, CA
Manufactured in China



Ford Motor Company trademarks and trade dress used under license to OJO Electric, LLC.