

OPN-2102i

Data Collector with Bluetooth



This manual provides specifications for the OPN-2102i Bluetooth data collector with laser barcode scanner.

The information in this document is subject to change without notice.

Document History

Model Number:	OPN-2102i	Specification Number:	SS16056
Edition:	1st	Original Spec Number:	(SS16017)
Date:	30-September-2016		

© 2016 Opticon. All rights reserved.

This manual may not, in whole or in part, be copied, photocopied, reproduced, translated or converted to any electronic or machine readable form without prior written consent of Opticon.

Limited Warranty and Disclaimers

Please read this manual carefully before installing or using the product.

Serial Number

A serial number appears on all Opticon products. This official registration number is directly related to the device purchased. Do not remove the serial number from your Opticon device. Removing the serial number voids the warranty.

Warranty

Unless otherwise agreed in a written contract, all Opticon products are warranted against defects in materials and workmanship for two years after purchase excluding batteries. Opticon will repair or, at its option, replace products that are defective in materials or workmanship with proper use during the warranty period. Opticon is not liable for damages caused by modifications made by a customer. In such cases, standard repair charges will apply. If a product is returned under warranty and no defect is found, standard repair charges will apply. Opticon assumes no liability for any direct, indirect, consequential or incidental damages arising out of use or inability to use both the hardware and software, even if Opticon has been informed about the possibility of such damages.

Packaging

The packing materials are recyclable. We recommend that you save all packing material to use should you need to transport your data collector or send it for service. Damage caused by improper packaging during shipment is not covered by the warranty.

Trademarks

Trademarks used are the property of their respective owners.

Opticon Inc. and Opticon Sensors Europe B.V. are wholly owned subsidiaries of OPTOELECTRONICS Co., Ltd., 12-17, Tsukagoshi 4-chome, Warabi-shi, Saitama, Japan 335-0002. TEL +81-(0) 48-446-1183; FAX +81-(0) 48-446-1184

SUPPORT

USA

Phone: 800-636-0090
Email: support@opticonusa.com
Web: www.opticonusa.com

Europe

Phone: +31235692728
Email: support@opticon.com
Web: www.opticon.com



Revision History

Product Name : OPN-2102i

Edition	Date	Page	Section	Description of Changes
1 st	2016/09 /30	-	-	

Contents

1 Abstract.....6

2 Overview6

3 Basic Specifications7

4 Detailed View9

5 Electrical Specifications.....10

5.1 USB 10

5.2 Wireless Charging 10

6 Interface Specifications.....10

6.1 USB Interface 10

6.1.1 Connector 10

6.1.2 USB Interface Circuit 10

6.2 Bluetooth 11

6.3 NFC Tag..... 11

7 Optical Specifications.....11

7.1 Basic Specifications 11

7.2 Laser Scanning Standards..... 12

7.2.1 Laser Scanning Tilt..... 12

7.2.2 Laser Scanning Curvature..... 12

8 Technical Specifications13

8.1 Barcode Test Sample..... 13

8.2 Scan Area and Depth of Field 14

8.3 Printed Contrast Signal (PCS) 15

8.4 Minimum Resolution..... 15

8.5 Pitch, Skew and Tilt..... 15

8.6 Curvature..... 16

9 Environmental Specifications.....16

9.1 Temperature..... 16

9.2 Humidity..... 16

9.3 Ambient Light Immunity..... 17

9.4 Dust and Drip Proof..... 17

9.5 Vibration Strength (without packing) 17

9.6 Vibration Strength (in individual packing)..... 17

9.7 Drop Impact Strength (without packaging)..... 18

9.8 Drop Impact Strength (in individual packaging) 18

9.9 Electrostatic Discharge Immunity 18

10 Regulatory Compliance19

10.1 LED Safety 19

10.2 Product Safety..... 19

10.3 EMC..... 19

10.4 Other..... 20



11	RoHS	20
12	Reliability	20
13	Precautions	20
13.1	Precaution against Laser Light.....	20
13.2	Handling	21
13.3	Radio Law.....	21
13.4	Bluetooth	22
13.5	Frequency Band	22
14	Product Labels	23
15	Packaging Specifications	24
15.1	Individual Packaging	24
15.2	Collective Packaging	25
16	Physical Features	26
16.1	Dimensions.....	26
16.2	Weight	26
16.3	Mechanical Drawing	26
17	Supported Symbologies	27
17.1	Default Setting.....	27
17.2	Supported Symbologies	27
17.2.1	1D Barcodes	27
17.2.2	GS1 Databar, Composite Code.....	28

Table of Figures

Figure 1: Detailed View	9
Figure 2: micro USB B Connector	10
Figure 3: Interface Circuit (USB)	10
Figure 4: Laser Scanning Specification.....	12
Figure 5: Scan Area and Depth of Field	14
Figure 6: Pitch, Skew and Tilt.....	15
Figure 7: Curvature.....	16
Figure 8: Drop Test.....	18
Figure 9: Product Label Position	23
Figure 10: Individual Packaging	24
Figure 11: Collective Packaging	25
Figure 12: Mechanical Drawing	26

1 Abstract

This manual provides specifications for the OPN-2102i compact laser data collector with built-in Bluetooth.

2 Overview

The OPN-2102i is compact battery powered portable laser scanner with a build-in wireless battery charger. Below are some of the key features:

- The OPN-2102i is a handy and simple to use data collector.
- The scanned barcode data can be transmitted to a host device through the USB interface or via the build-in Bluetooth interface.
- The scanner can work with many Bluetooth enabled host devices, such as PCs, tablets and smart phones.
- Bluetooth SPP (Serial Port Profile) and HID (Human Interface Device Profile) are implemented.
- Built-in NFC tag allows for “tap to connect” on supported telephones which greatly simplifies the pairing process of Bluetooth.
- A red LED aiming line toward a target bar code can help the users find the appropriate scanning position.
- Alcohol can be used to wipe the scanner clean
- The power source is a 3.7 V 600 mAh (typ.) Li-ion polymer battery.
- The OPN-2102i supports wireless charging and a dedicated charging cradle, the CRD-3000 is available for that. The OPN-2102i can also be charged via its USB interface.
- The scanner is Apple MFi certified.



3 Basic Specifications

Item		Specification		Note		
Control Section	CPU	32 bit CISC / 96 MHz				
	FROM	512 Kbyte + 32 Kbyte				
	SRAM	96 Kbyte				
	FROM (storage)	1 Mbyte		For data area only		
Input Section	Key type	2 key: trigger, function				
Indicator	LED	2 bi-colors LEDs (red, green) and 1 blueLED				
	Buzzer	Loudness (3-level) / tone adjustable				
	Vibration motor	Strength (3-level) / duration adjustable				
RTC	Contents	Year, month, date, hour, minute, second		Data and time are lost when the main battery is removed.		
	Accuracy	± 90 seconds per month				
Interface	Bluetooth	Frequency	2402 ~ 2480 MHz			
		Specification	Bluetooth Ver 2.1 compliant			
		Communication distance	10 m		Not guaranteed.	
		Output level	Class 2		Max output 4 dBm	
		Profile	SPP / HID			
	NFC tag	ISO/IEC 14443 TYPE A, TYPE B JISX6319-4				
USB	<ul style="list-style-type: none"> • Full-Speed 12Mbps (HID/COM) • Hi-Power Bus-powered supported 					
Optical Section	Light-emitted element		Red laser diode			
	Laser wavelength / output		650±10nm 1mW or less		Wavelength in temperature 25°C	
	Scan rate		100±20scan/sec			
Supported 1D Symbolologies	Symbologies		JAN, EAN, UPC-A, UPC-E, NW-7 (Codabar), Industrial 2 of 5, Interleaved 2 of 5, Code 11, Code 39, Code 93, Code 128		Refer to Section 17. for details	
	Minimum resolution		Code 39 : 0.076mm		PCS 0.9	
	Curvature		R ≥ 15 mm (8-digit JAN) R ≥ 20 mm (13-digit JAN)		PCS 0.9	
	Barcode width		100 mm wide 0.2 mm resolution Code 39 (DOF 150 mm) is readable:			
	Scan angle	Pitch : $\alpha \leq \pm 35^\circ$		PCS 0.9		
		Skew : $\beta \leq \pm 50^\circ$ (Excluding dead zone)				
		Tilt : $\gamma \leq \pm 20^\circ$				
	Depth of Field	Code 39	Resolution (1.0)	50 ~ 420		
			Resolution (0.5)	45 ~ 340		
			Resolution (0.25)	40 ~ 250		
Resolution (0.15)			40 ~ 155			
Resolution (0.127)			45 ~ 130			

Item		Specification	Note	
	Minimum PCS	0.3 or more	MRD 32% or more	
Power Section	Main battery	Lithium-polymer 600 mAh (typ.)		
	Up-time	25 hours or more	*1	
	Feeding system	Electromagnetic guidance wireless charging, microUSB		
	Operating (charging) voltage	4.5 ~ 5.5V	Charging with USB	
	Current consumption	Charging	Less than 500 mA	
Environmental Specifications	Temperature	Operating	-10 ~ 50°C	
		Storage	-20 ~ 60°C	
	Humidity	Operating	20 ~ 85%	No condensing No frost
		Storage	20 ~ 85%	
	Ambient light immunity	Fluorescent	4,000 lx or less	
		Sunlight	80,000 lx or less	
	Vibration	10 Hz ~ 100 Hz, acceleration of 19.6 m/s ² , 60 minutes per cycle, repeat once in each X, Y and Z-direction		
Drop	Drop the scanner 18 times (6 faces x 3) from a height of 150 cm onto a concrete floor			
Dust and drip proof	IP54 equivalent			
Regulatory Compliance	LED safety	JIS C 6802:2011 Class2 IEC 60825-1 Ed.2: 2007 Class 2 CDRH Class II		
	Product safety	EN60950-1:2005 IEC60950-1:2006		
	EMC	EN 55024:2010 EN 55032:2012+AC: 2013 EN 301 489-1 V1.9.2 EN 301 489-17 V2.2.1 EN 300 328 V1.9.1 EN 302 291-2 V1.1.1 FCC Part 15 Subpart C, Subpart B ClassB VCCI Class B		For residential, commercial and light-industrial environments
	European conformity	CE Marking		
		Certification for Construction Design of Specified Radio Equipment		
Other	Bluetooth logo certification MFi license			
Immunity Test	ESD	No distraction	Air discharge (direct): ±15 kV	Conditions: IEC61000-4-2 compliant
		No malfunction	Air discharge (direct): ±8 kV	
Physical Features	Dimensions	83.0 × 36 × 21.5 (WDH mm)		
	Weight	Approx. 60 g		Excluding accessories

*1: When a barcode is read twice every 10 seconds at room temperature in a constant Bluetooth connection (SPP master mode).

4 Detailed View

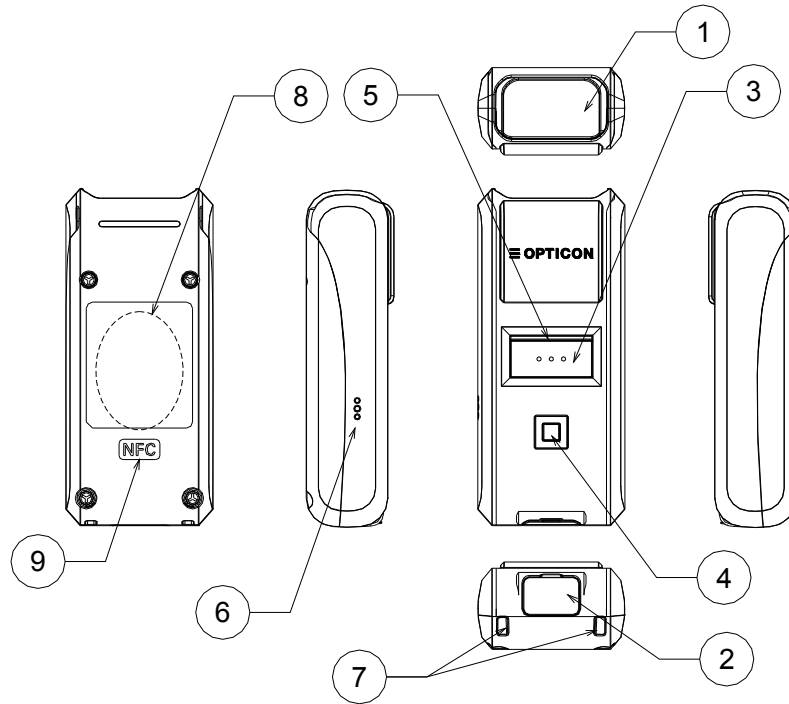

Figure 1: Detailed View

No	Name	Description
1	Scan Window	The laser light is emitted through this window. Ensure that the lens is not exposed to dust and dirt before scanning.
2	USB Cap	Cap for USB connector part used to make the scanner IP54 water tight.
3	Trigger Key	Press this key to enable the laser and start reading barcodes.
4	Function Key	The function of this key depends on the installed application.
5	LED	Indicates operating status, such as bar code reading, Bluetooth connection, warning etc.
6	Buzzer Orifice	Holes for buzzer.
7	Strap Orifice	Holes for attaching a hand strap.
8	Charging Coil	The charging coil is located here with which the dedicated cradle can supply power to the scanner.
9	NFC	This is the location of the NFC tag. Hold an NFC reader close to this area when the tag has to be read.

5 Electrical Specifications

5.1 USB

Supply Voltage	: 4.5-5.5V
Bus-power (Class)	: 500mA max (hi-power)
Current consumption	: Less than 500mA

5.2 Wireless Charging

Feeding system	: Electromagnetic induction
Power consumption	: Less than 5W

6 Interface Specifications

The OPN-2102i supports two types of interfaces; USB and Bluetooth.

6.1 USB Interface

Interface is Full Speed USB interface.

6.1.1 Connector

Signal Name	Contact Number
VCC	1
DATA(-)	2
DATA(+)	3
(NC)	4
GND	5

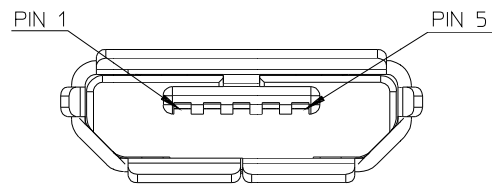

Figure 2: micro USB B Connector

6.1.2 USB Interface Circuit

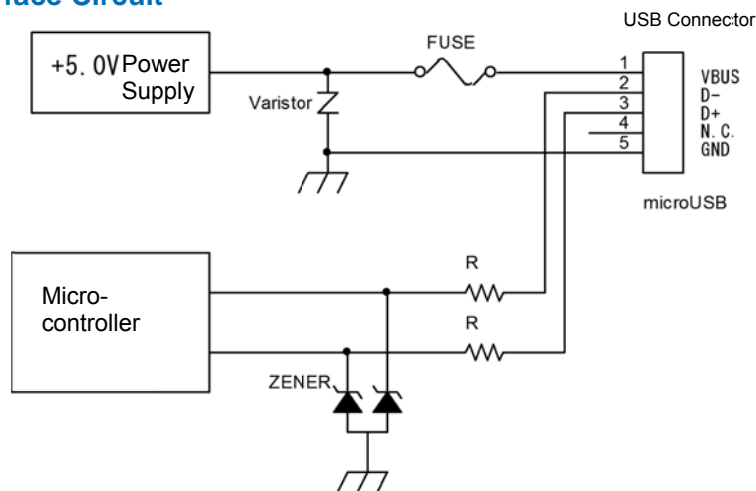

Figure 3: Interface Circuit (USB)

6.2 Bluetooth

The specifications of the OPN-2102i Bluetooth interface are as follows:

Frequency	: 2402 ~ 2480 MHz
Specification	: Bluetooth Ver 2.1 compliant
Communication distance	: 10 m
Output level	: Class 2 (max 4 dBm)
Implemented profile	: SPP / HID
Communication configuration	: 1 to 1
Operating mode in communication	: Master / Slave mode
Security mode	: Authentication supported
Encryption	: Encryption supported

6.3 NFC Tag

OPN2102i has NFC tag built-in which record Bluetooth device address.

Frequency:	13.56MHz
Standard :	ISO/IEC 14443 TYPE A, TYPE B and JISX6319-4
Recorded Contents:	

Total 928 byte	
	NDEF
	Record #1
	type: "application/vnd.bluetooth.ep.oob"
	OOB data length: 8 Byte
	MAC address: 00:12:6A:xx:xx:xx
	Record #2
	type: "T"
	TEXT data length: 15 Byte
	TEXT data: "00126Axxxxxx"
	Free area
Reserved area	

*xx will differ according to product.

Rewriting from external: possible

7 Optical Specifications

7.1 Basic Specifications

Item	Characteristics	Unit
Light-Emitting Element	Red laser diode	-
Emission Wavelength	650 ±10 (25° C)	nm
Light Output	< 1.0	µW
Scanning Method	Bi-directional scanning	-
Scanning Speed	100 ±20	scans/sec
Scan Angle	Scan Angle	54 ±5
	Effective Scan Angle	44 (Min)

7.2 Laser Scanning Standards

7.2.1 Laser Scanning Tilt

Vertical differences between both ends of a laser scanning line:

- Up to 1.2 degrees in a vertical direction from the scan origin (scanning mirror).
- Up to 3.1 mm measured at 150 mm from the scan origin and with zero skew angle.
- Measure in the middle of the scanning line.

7.2.2 Laser Scanning Curvature

The maximum differences between the laser scanning line and a straight line connecting the both ends of the scanning line:

- Up to 1.27 degrees from the scan origin (scanning mirror).
- Up to 3.3 mm measured at 150 mm from the scan origin.
- Measure in the middle of the scanning line.

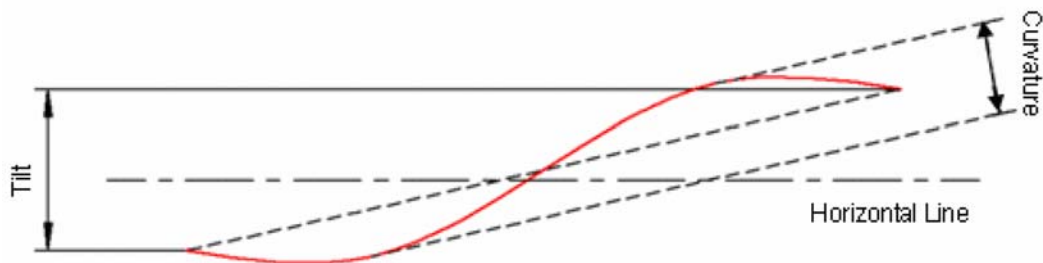

Figure 4: Laser Scanning Specification

8 Technical Specifications

Ambient conditions are as follows unless otherwise specified in each section:

<Conditions>

Ambient Temperature and Humidity	Room temperature, room humidity
Ambient Light	500 ~ 900 lx
Barcodes	Refer to Section 8.1.
Background	Black
Power supply voltage	5V (USB)
Reading Test	Accept the performance with 10 consecutive successes in reading. Each reading should be done in 0.5 seconds or less.

8.1 Barcode Test Sample

<Code 39>

Resolution	Symbology	PCS	Quiet Zone	No. of Digits
1.0 mm	Code 39	0.9	25 mm	1
0.5 mm			18 mm	3
0.25 mm			10 mm	8
0.25 mm			10 mm	9
0.15 mm			7 mm	10
0.127 mm			5 mm	4
0.076mm			5 mm	5

<JAN>

Resolution	Symbology	PCS	Quiet Zone	No. of Digits
0.26 mm	JAN	0.9	10 mm	13
0.26 mm			10 mm	8

8.2 Scan Area and Depth of Field

The scanner is able to read in the area between the two arcs that are centered on the scan origin with a center line distance from the front of the scanner as indicated for each resolution.

Resolution	No. of Digits	Depth of Field (mm)
1.0mm	1	50 ~ 420
0.5mm	3	45 ~ 340
0.25mm	8	40 ~ 250
0.15mm	10	40 ~ 155
0.127mm	4	45 ~ 130

<Conditions>

Barcode : Code 39 specified in Section 8.1.
Angle : $\alpha = 0^\circ$, $\beta = + 15^\circ$, $\gamma = 0^\circ$

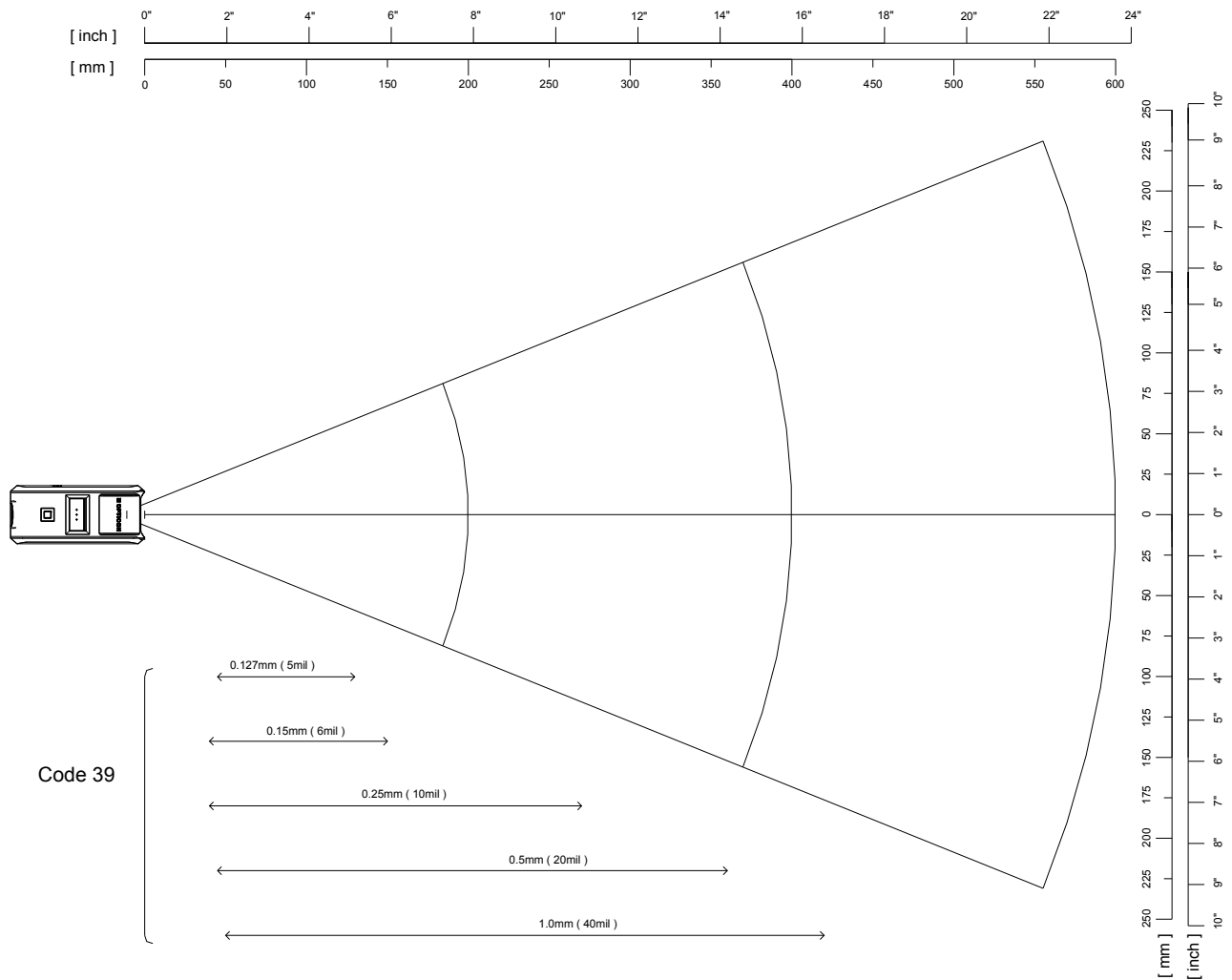

Figure 5: Scan Area and Depth of Field

8.3 Printed Contrast Signal (PCS)

PSC 0.3 or higher (70% or higher reflectivity of space and quiet zone)

$$PCS = \frac{\text{Reflectance of white space} - \text{Reflectance of black bar}}{\text{Reflectance of white space}}$$

Note:

Be sure to keep the optical window clean without dirt or scratches, or it may have a detrimental effect on the reading characteristics.

8.4 Minimum Resolution

Minimum Resolution 0.076mm

<Conditions>

Barcode	Code 39 specified in Section 8.1
Distance	60 mm from the front edge of the scanner
Angle	Skew angle $\beta = 15^\circ$

8.5 Pitch, Skew and Tilt

Pitch	: $\alpha \leq \pm 30^\circ$
Skew	: $\beta \leq \pm 50^\circ$ (Excluding dead zone)
Dead Zone	: $\beta \leq \pm 8^\circ$ (Decoding may fail in some areas as a result of specular reflection)
Tilt	: $\gamma \leq \pm 20^\circ$

<Conditions>

Bar code	<Pitch, Skew and Dead Zone> Resolution 0.25 mm, 9-digit Code 39 specified in Section 8.1. <Tilt> Resolution 0.26 mm, JAN-13 specified in Section 8.1.
Distance	100 mm from the edge of the scan engine
Curvature	$R = \infty$
Angle	Pitch angle : $\beta = +15^\circ, \gamma = 0^\circ$ Tilt angle : $\alpha = 0^\circ, \beta = +15^\circ$ Skew angle / Dead zone: $\alpha = 0^\circ, \gamma = 0^\circ$

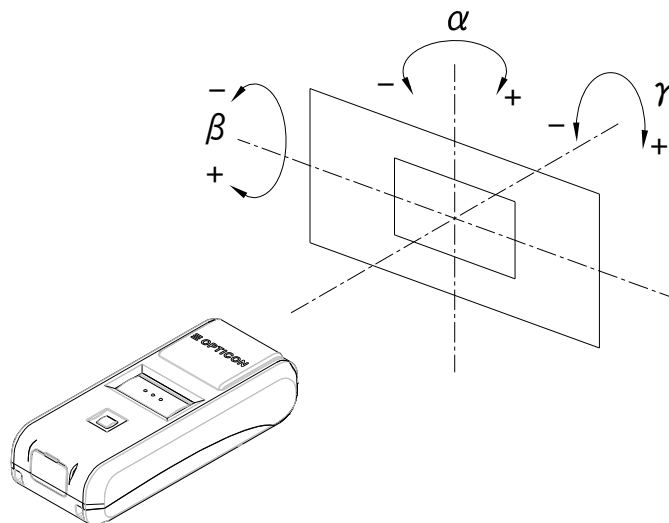

Figure 6: Pitch, Skew and Tilt

8.6 Curvature

8-digit JAN: $R \geq 15 \text{ mm}$
 13-digit JAN: $R \geq 20 \text{ mm}$

<Conditions>
 Barcode Resolution 0.26 mm, JAN specified in Section 8.1.
 Distance 100 mm from the edge of the scan engine
 Angle Skew angle $\beta = +15^\circ$

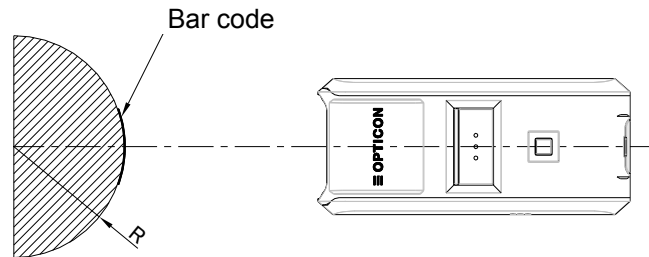

Figure 7: Curvature

Note:

The reading performance may deteriorate if there is specular reflection of the laser light, this typically will occur when the reflectivity of the barcode is high.

9 Environmental Specifications

9.1 Temperature

Scanning performance is guaranteed when the ambient temp. is within the following range:

Operating Temperature: $-10 \sim 50 \text{ }^\circ\text{C}$
 Storage Temperature : $-20 \sim 60 \text{ }^\circ\text{C}$

Please charge when the temperature is between 0 and 40°C. When the temperature is over 40°C, charging may stop to prevent battery breakdown..

9.2 Humidity

Scanning performance is guaranteed when the ambient humidity within following range:

Operating Humidity: 20 ~ 85%RH (no condensation, no frost)
 Storage Humidity: 20 ~ 85%RH (no condensation, no frost)

9.3 Ambient Light Immunity

Scanning performance is guaranteed when the illumination on a barcode surface is between zero and the following values:

Incandescent light:	4,000 lx
Fluorescent light:	4,000 lx (excluding high-frequency lighting)
Sunlight:	80,000 lx

<Conditions>

Barcode:	Optoelectronics Test Sample Resolution 0.25 mm, 9-digit Code 39, Quiet Zone 10 mm, N/W Ratio = 1 : 2.5
Distance:	100 mm from the front edge of the scanner
Angle:	$\alpha = 0^\circ$, $\beta = +15^\circ$, $\gamma = 0^\circ$
Curvature:	$R = \infty$
Power-supply voltage:	5.0V

* Avoid direct or specula reflection from the laser beam as it may blind the scanners optical receiver.

9.4 Dust and Drip Proof

IEC IP54 equivalent

Protection against solid objects: Level 5 equivalent (Dust proof type)

Prevent dust ingress to inside. Even if slight dust intrusion will not inhibit normal operation.

Protection against liquids: Level 4 equivalent (Splash proof type)

Protected against water splash from any direction.

* () is JIS drip-proof type.

9.5 Vibration Strength (without packing)

There shall be no sign of malfunction after the following vibration test.

Vibration test: Increase the frequency of the vibration from 10Hz to 100Hz at an accelerated velocity of 19.6m/s^2 (2.0 G) for 30 minutes (60 minutes per cycle) in non-operating state. Repeat this in each X, Y and Z direction.

9.6 Vibration Strength (in individual packing)

There shall be no sign of malfunction after the following vibration test.

Vibration test: Increase the frequency of the vibration from 10Hz to 100Hz at an accelerated velocity of 19.6 m/s^2 (2.0 G) for 30 minutes (60 minutes per cycle) in individually packaged state. Repeat this in each X, Y and Z direction.



9.7 Drop Impact Strength (without packaging)

There shall be no sign of malfunction after the following drop test.

Drop test: Drop the scanner 18 times in total (3 times at each 6 face), from a height of 150 cm onto a concrete floor as shown below.

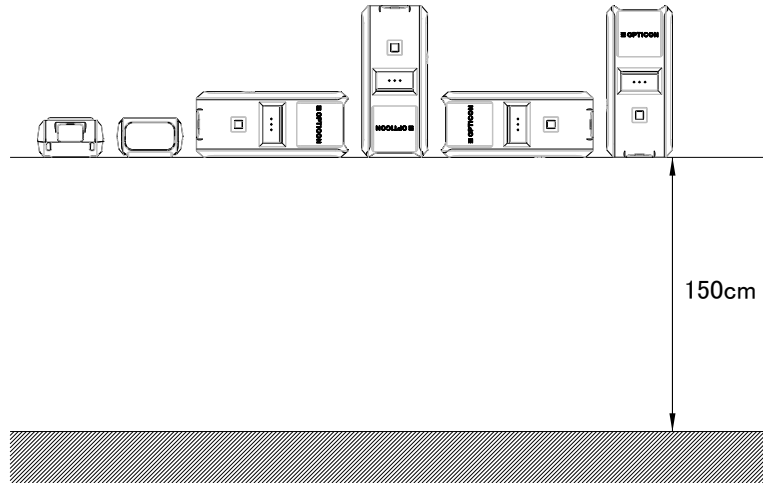

Figure 8: Drop Test

9.8 Drop Impact Strength (in individual packaging)

There shall be no sign of malfunction after the following drop test.

Drop test: Drop an individually packaged scanner 10 times in total, at any of 1 corner, 3 edges, and 6 faces, from a height of 150 cm onto a concrete floor.

9.9 Electrostatic Discharge Immunity

Air discharge	±8 kV max. (No malfunction) ±15 kV max. (No destruction)
Measurement environment	An electrostatic testing device compliant with IEC 61000-4-2
Discharge resistance	330 Ω
Charging capacitor	150 pF

10 Regulatory Compliance

10.1 LED Safety

JIS C 6802 : 2011 Class 2
IEC 60825-1 Ed.2: 2007 Class 2
CDRH Class II

10.2 Product Safety

EN60950-1:2005
IEC60950-1:2006

10.3 EMC

R & TTE Directive

- EN 55024:2010
- EN 55032:2012+AC: 2013
- EN 301 489-1 V1.9.2
- EN 301 489-17 V2.2.1
- EN 300 328 V1.9.1
- EN 302 291-2 V1.1.1

FCC Part 15 Subpart C, Subpart B ClassB

Federal Communications Commission Notices

This device complies with FCC radiation exposure limits set forth for an uncontrolled environment.

This product complies with Part 15 of the FCC Rules. Operation is subject to the following two conditions:

- (1) this device may not cause harmful interference, and
- (2) this device must accept any interference received, including interference that may cause undesired operation.

Harmful Interference Notice

This product has been tested and complies with the specifications for a Class B digital device, pursuant to Part 15 of the FCC Rules. These limits are designed to provide reasonable protection against harmful interference in a residential installation. This equipment generates, uses, and can radiate radio frequency energy and, if not installed and used according to the instructions, may cause harmful interference to radio communications. However, there is no guarantee that interference will not occur in a particular installation. If this equipment does cause harmful interference to radio or television reception, which is found by turning the equipment off and on, the user is encouraged to try to correct the interference by one or more of the following measures:

- Reorient or relocate the receiving antenna
- Increase the separation between the equipment or devices
- Connect the equipment to an outlet other than the receiver's
- Consult a dealer or an experienced radio/TV technician for assistance

Changes or modifications not expressly approved by the party responsible for compliance could void the user's authority to operate the equipment.



VCCI Class B

This is a Class B product, to be used in a domestic environment, based on the Technical Requirement of the Voluntary Control Council for Interference from Information Technology Equipment (VCCI). If this is used near a radio or television receiver in a domestic environment, it may cause radio interference.

10.4 Other

- Bluetooth logo certification
- MFi license

“Made for iPod,” “Made for iPhone,” and “Made for iPad” mean that an electronic accessory has been designed to connect specifically to iPod, iPhone, or iPad, respectively, and has been certified by the developer to meet Apple performance standards. Apple is not responsible for the operation of this device or its compliance with safety and regulatory standards. Please note that the use of this accessory with iPod, iPhone, or iPad may affect wireless performance.



- Certification for Construction Design of Specified Radio Equipment

• Classification of Specified Radio Equipment	Article 2 Paragraph 1, Item 19 Low power data communication system in 2.4 GHz band
• Model Name	OPA-26X1
• Certificate Number	201-125603

11 RoHS

RoHS compliance.

RoHS: The restriction of the use of certain hazardous substances in electrical and electronic equipment, 2011/65/EU

12 Reliability

MTBF (Mean Time Between Failures) 50,000 hours

13 Precautions

13.1 Precaution against Laser Light



- Do not stare into the laser light from the scanning window. It may harm your eyes.
- Do not point the laser directly at others' eyes. It may harm their eyes.
- Do not stare into the beam with optical instruments. It may harm your eyes.
- Use of controls or adjustments or performance of procedures other than those specified herein may result in hazardous radiation exposure.



13.2 Handling

Handle this product carefully. Do not deliberately subject it to any of the following.

(1) Shock:

- Do not drop this product from a height greater than specified in this manual.
- Do not place this product under or between any heavy items.
- Do not swing the cable around.

(2) Temperature Conditions:

- Do not use this product at temperatures outside the specified range.
- Do not pour boiling water on this product.
- Do not throw this product into a fire.

(3) Foreign Materials:

- Do not immerse this product in water or other liquid.
- Do not expose this product to chemicals.

Others

- Do not disassemble this product.
- Do not use this product near a radio or a TV. It may cause reception problems.
- This product may be affected by a momentary voltage drop caused by lightning.
- Please use within the range of operating voltage. Using outside of operating voltage may cause malfunction.
- Do not attach piece of metal or metal foil to the back of charging coil stored part and NFC coil stored part. Also, do not fix anything that prevents placing to charging cradle.
- Please securely close the USB cap to keep the waterproof.
- Do not pull strong, fold and bend the cables.
- Do not add shock or apply load to jack and connector.
- When charging is completed, please remove USB cable from connector.

13.3 Radio Law

This product qualifies as specified radio equipment for radio stations of 2.4 GHz band data communication system and has obtained the Certification for Construction Design of Specified Radio Equipment. Therefore, radio station license is not required in Japan.

The following activities are prohibited under the Radio Law:

- Remodelling and disassembly
- Peeling off the certificate label

Do not use this equipment under the following environment, as radio interference may affect other device and end up with causing physical or material damage.

- Safety apparatus and medical device for human body protection
- Environment where is concerned to cause serious damage

13.4 Bluetooth

- This product supports Bluetooth wireless communication with other Bluetooth devices that have the same profile
- This product complies with Bluetooth standards; however, its communication performance with untested devices is not guaranteed.
- Bluetooth devices use the 2.4 GHz frequency band that is shared among other devices. It may affect the communication speed and distance between this product and the host device.
- The communication speed and distance vary depending on the interference and radio wave condition between this product and the host device.

13.5 Frequency Band

This product uses the 2.4 GHz frequency band. Read carefully the followings before using this product.

In the frequency band of this product, scientific, medical and industrial devices including microwaves are used. Also other radio stations including local private radio station for mobile object identification requiring license for such as manufacturing lines at factories, specific power-saving radio station requiring no license and amateur radio station are managed.

1. Make sure that “other radio stations” are not managed in the frequency band 2.4 GHz before using this product.
2. In case that radio interference occurs between this product and “other radio stations,” change the service space immediately, or stop transmitting radio wave to avoid the interference.
3. If you have any questions or troubles, please contact our sales office.

* This specification manual is subject to change without prior notice.

14 Product Labels

The product labels are affixed to the scanner as shown below.

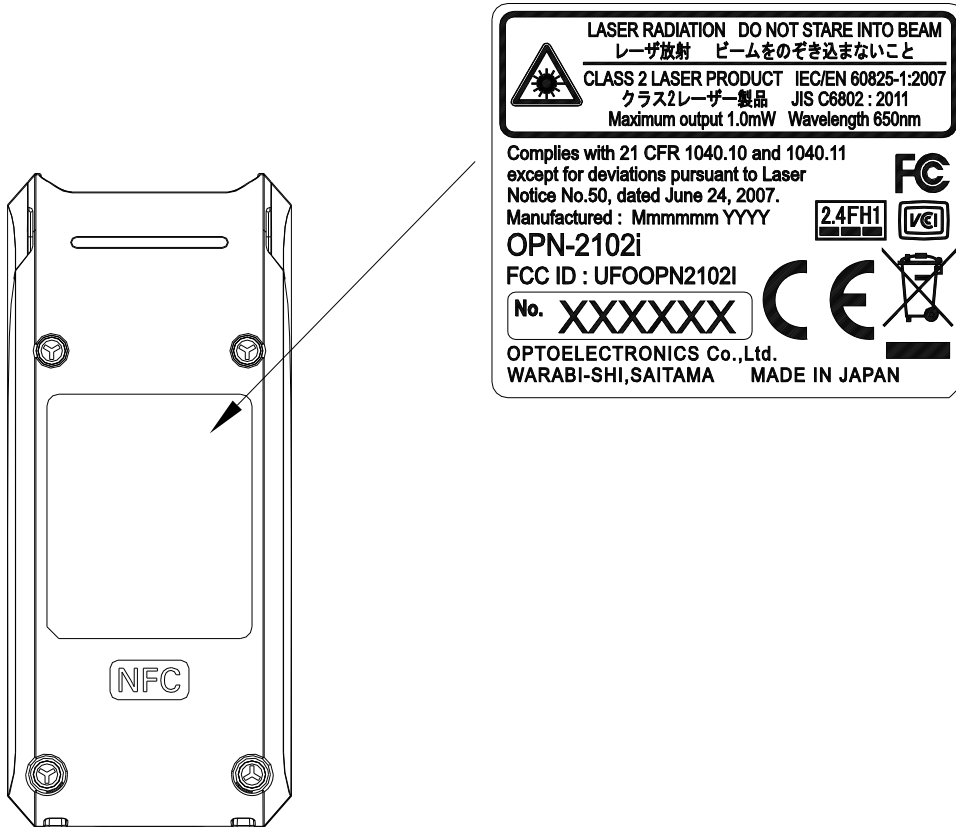

Figure 9: Product Label Position

15 Packaging Specifications

15.1 Individual Packaging

Assembled package size: Approx. 125 × 112 × 40 (WDH mm)
Weight: Approx. 140g

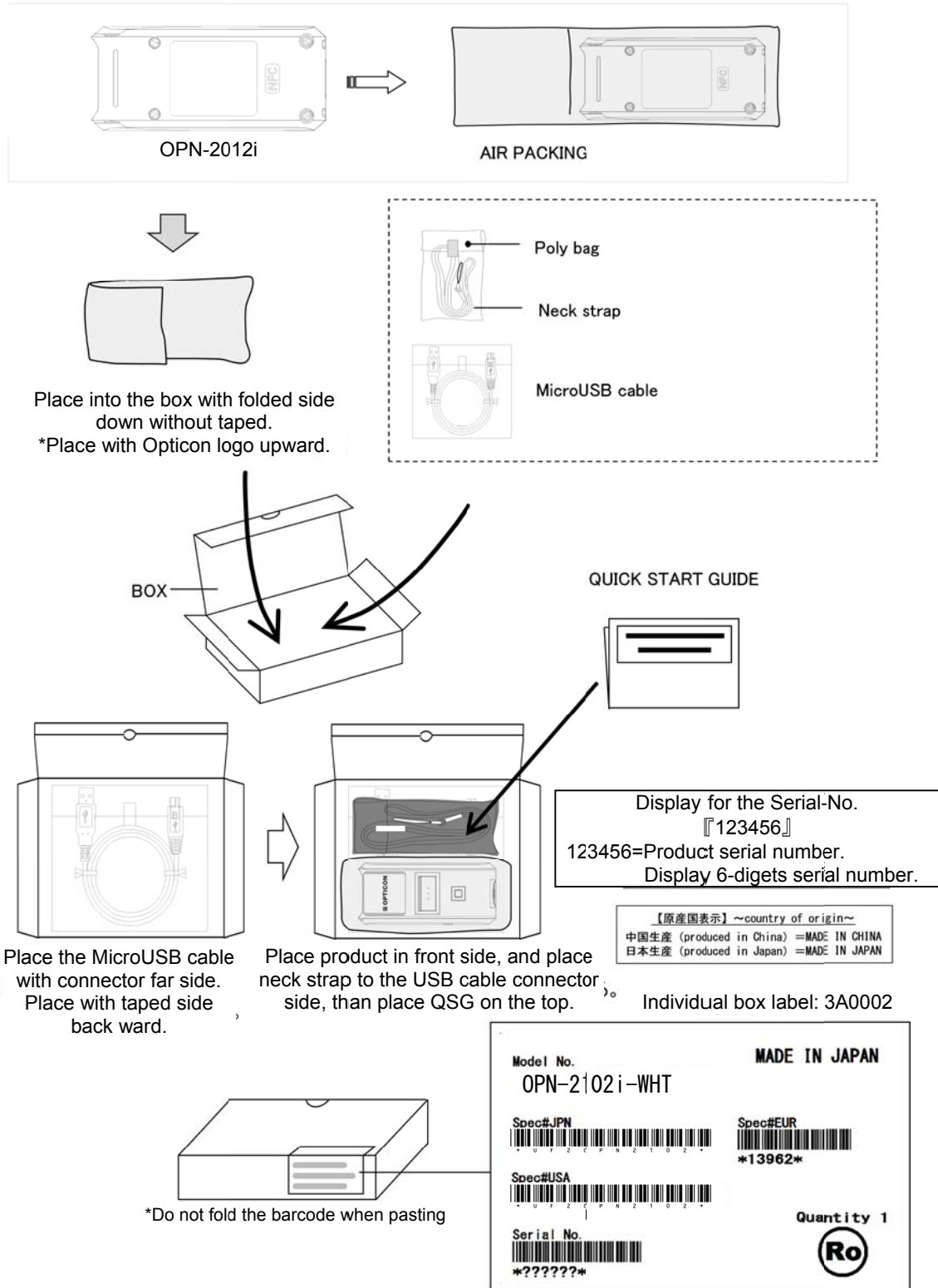
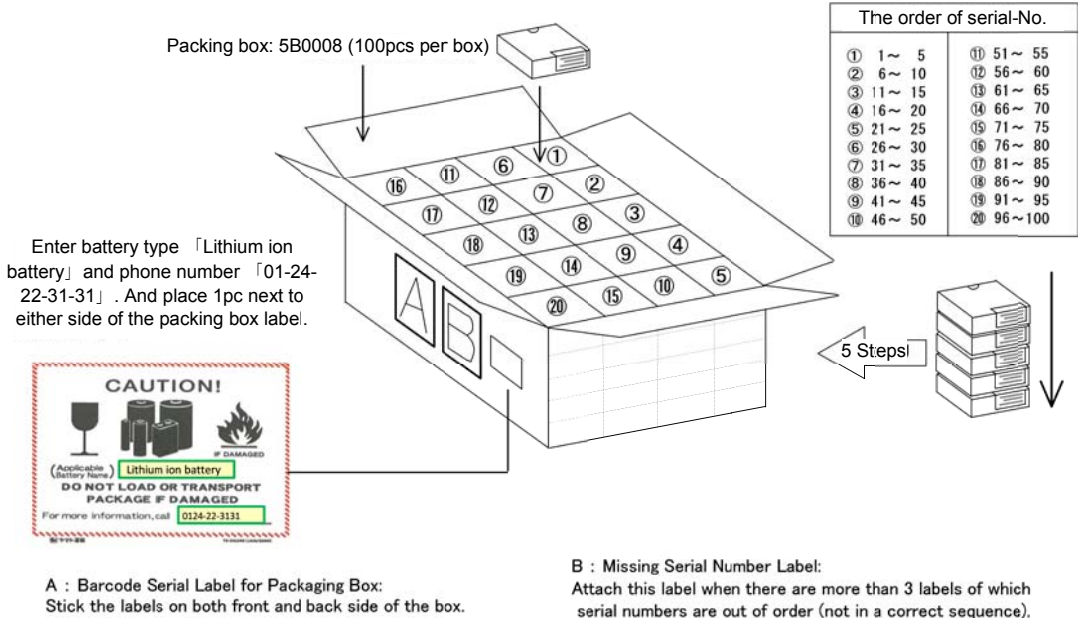

Figure 10: Individual Packaging

15.2 Collective Packaging

100pcs per box
Assembled package size : Approx. 595 × 520 × 245 (WDH mm)
Weight: Approx. 15kg



(3C0006)

UNIVERSAL C/No. △△
MADE IN ▲▲▲▲▲

Product OPN-2102i-WHT

P0# [Barcode] *△△△△△-△△*

Spec#JPN [Barcode] *U F 2 0 F N 2 1 1 2 *

Spec#EUR [Barcode] *1 3 9 0 2 *

Spec#USA [Barcode] *0 P N 2 1 0 2 1 0 9 *

Q'ty [Barcode] S/N(from) [Barcode] *△△△△△△*
△△/△△△ S/N(to) [Barcode] *△△△△△△*

Missing Serial Number	Missing Q'ty △
1	[Barcode] *△△△△△△*
2	[Barcode] *△△△△△△*

ROM-Ver. (MAIN) TC22J01
ROM-Ver. (Bluetooth) TD01J05
Shipping Date 20△△/△△/△△

Ro
OPTOELECTRONICS CO., LTD.

(3C0007)

UNIVERSAL C/No. △△
MADE IN ▲▲▲▲▲

Missing Serial Number	Missing Q'ty △△
3	[Barcode] *△△△△△△△△*
4	[Barcode] *△△△△△△△△*
5	[Barcode] *△△△△△△△△*
6	[Barcode] *△△△△△△△△*
7	[Barcode] *△△△△△△△△*
8	[Barcode] *△△△△△△△△*
9	[Barcode] *△△△△△△△△*
10	[Barcode] *△△△△△△△△*
11	[Barcode] *△△△△△△△△*
12	[Barcode] *△△△△△△△△*

OPTOELECTRONICS CO., LTD.

【原産国表示】 ~country of origin~
中国生産 (produced in China) =MADE IN CHINA 日本生産 (produced in Japan) =MADE IN JAPAN

Figure 11: Collective Packaging

16 Physical Features

16.1 Dimensions

83.0 × 36.0 × 21.5 (DWH mm)

16.2 Weight

Approx. 60 g (excluding accessories)

16.3 Mechanical Drawing

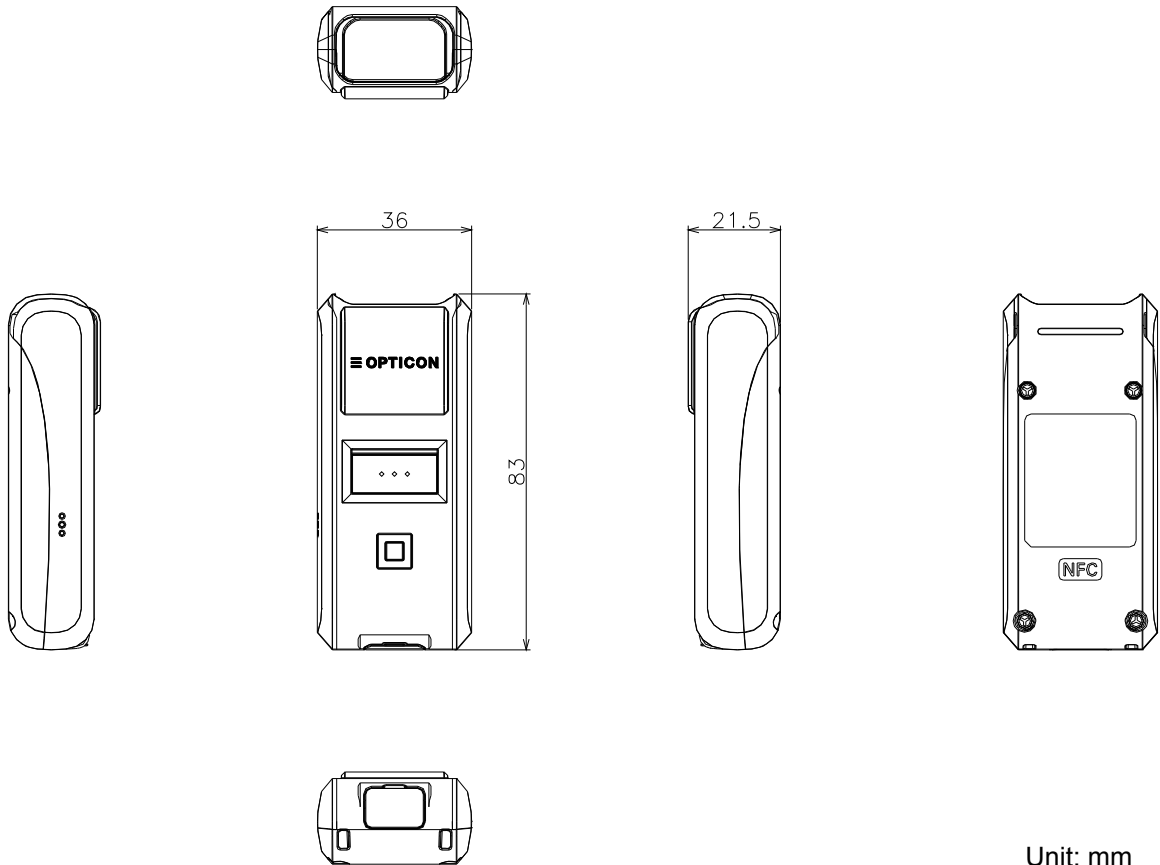



Unit: mm

Figure 12: Mechanical Drawing

17 Supported Symbologies

17.1 Default Setting

The scanner is set to default by reading the following menu label.
Recorded contents of the NFC tag will also return to default.

Function	Menu label	Menu code
SET		ZZ
Default		SO
END		ZZ

17.2 Supported Symbologies

17.2.1 1D Barcodes

Code type	Default	Minimum length	Note
UPC	<input type="radio"/>	-	
UPC Add-on 2			
UPC Add-on 5			
EAN (JAN)	<input type="radio"/>	-	
EAN Add-on 2			
EAN Add-on 5			
EAN-13	<input type="radio"/>		
EAN-13 Add-on 2			
EAN-13 Add-on 5			
EAN-8	<input type="radio"/>		
EAN-8 Add-on 2			
EAN-8 Add-on 5			
Code 39	<input type="radio"/>	1	Not transmit ST/SP
Tri-Optic	<input type="radio"/>	-	Not transmit ST/SP
Codabar (NW7)	<input type="radio"/>	5	Not transmit ST/SP
Industrial 2 of 5	<input type="radio"/>	5	
Interleaved 2 of 5	<input type="radio"/>	6	
S-Code		5	
Code 128	<input type="radio"/>	1	GS1 conversion (setting required)
Code 93	<input type="radio"/>	1	
IATA	<input type="radio"/>	5	
MSI/Plessey	<input type="radio"/>	3	
UK/Plessey		2	
TELEPEN	<input type="radio"/>	1	
Code 11		1	
Matrix 2 of 5		5	
Chinese Post Matrix 2 of 5		-	
Korean Postal Authority		-	

17.2.2 GS1 Databar, Composite Code

Code type	Default	Note
GS1 DataBar •GS1 DataBar Omnidirectional •GS1 DataBar Truncated •GS1 DataBar Stacked •GS1 DataBar Stacked Omnidirectional		GS1 conversion (setting required)
GS1 DataBar Limited		
GS1 DataBar Expanded •GS1 DataBar Expanded •GS1 DataBar Expanded Stacked		

