

Master Specifications	
2D Data Collector with Bluetooth	
Product Name	PX-35
Specification No	SSxxxxx
Edition	Initial release
Date of Publication	Dec 6,2010
Original Doc. No.	SS10016

OPTOELECTRONICS Co., Ltd.
4-12-17 Tsukagoshi,
Warabi-shi, Saitama,
335-0002 Japan

TEL: 81+(0)48-446-1183
FAX: 81+(0)48-446-1184

Revision History

Specification No.: SSxxxxx

Product name : PX-35

Revision	Date	Section	Description of Changes
Initial release	2010/12/6	-	-

Table of Contents

1. Abstract	1
2. Overview	1
3. Physical Features	2
4. Basic Specifications	4
5. Optical Specifications.....	7
6. Technical Specifications.....	7
7. Bluetooth	11
8. Serial Label	12
9. Packaging Specifications.....	13
10. Durability	13
11. Warranty	16
12. Regulatory Compliance	17
13. RoHS.....	18
14. Precautions	18
Appendix 1	21
Appendix 2	22

1. Abstract

This manual provides specifications for the data collector with an embedded 2D data collector which offers Bluetooth, PX-35.

2. Overview

- PX-35 consists of CMOS image sensor and auto focus.
- Scanned data is output via Bluetooth interface.
- Bluetooth and IrDA (for the communication with the dedicated cradle) interface enables data communication with higher models.
- This product is compliant with RoHS.

2.1. Product / Model Name

Product name: PX-35

2.2. Features of PX-35

- Compact and handy design
- The data collector is able to read 2D barcodes.
- Stored data is sent to the recipient through Bluetooth interface. On the other hand, IrDA can communicate with host PC via the dedicated cradle.
- Embedded Bluetooth is compliant to version 1.2 and has installed profile.
- PX-35 can operate for a long time with a dedicated built-in lithium-ion battery (1880mh).
- Unit is charged when placing it on the dedicated cradle.
(To directly connect the dedicated adapter to PX-35 can also charge the unit.)

3. Physical Features

3.1. Dimensions

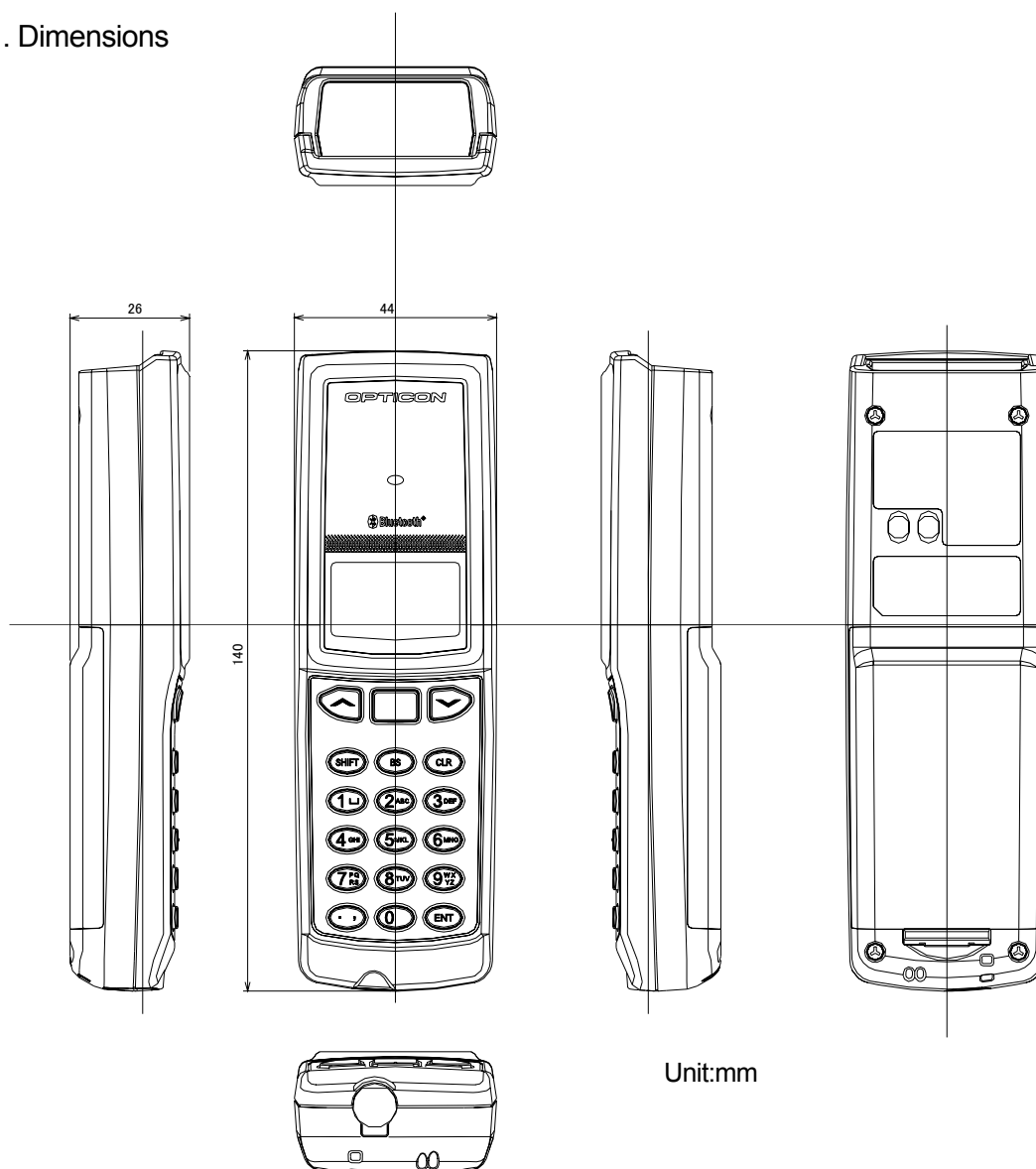

Figure1 : Dimensions

3.2. Weight

Max. 132g (including lithium-ion battery pack)

3.3. Physical Features

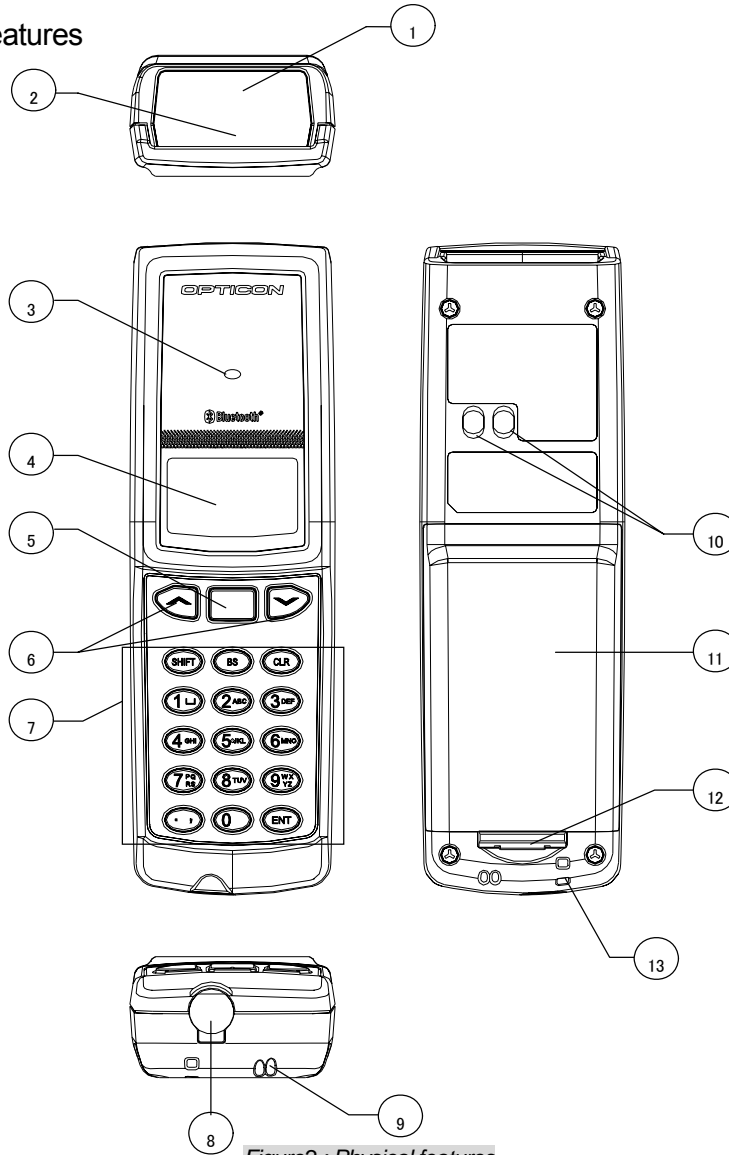

Figure2 : Physical features

No.	Item	Specification
1.	Scanning window	LED light for scanning barcode is emitted from the window.
2.	IrDA	Use for the communication with dedicated cradle
3.	LED	To notify the status of barcode scanning, Bluetooth communication, and warnings so on.
4.	LCD	Indicates scanned barcodes and operational items
5.	Trigger key	Press when scanning barcodes
6.	Up / Down keys	Used when selecting items from a menu.
7.	10 operational keys	Used for numerical, "ENTER", decimal point input.
8.	DC Jack	Used for the dedicated power supply
9.	Speaker	
10.	Terminals	Used to charge a lithium-ion battery of a unit when placing the unit on the dedicated terminal
11.	Battery cover	Remove when replacing the rechargeable battery
12.	Battery cover lock	Used to lock / open the battery cover
13.	Strap hole	Hole for attaching a hand strap

4. Basic Specifications

Item	Specification		Remark
Control section	CPU	32Bit RISC Micro computer (ARM7 Core)	Produced by ST Micro
	Embedded ROM	256Kbyte + 16Kbyte (for DATA)	
	Embedded RAM	64Kbyte	
Memory	FROM(NOR)	4Mbyte (User area: about 1Mbyte)	OS/AP
	SRAM	2Mbyte (User area : about 480kbyte) 4Mbyte (Option)	for WORK/DATA
OS	μITRON		
Display section	LCD	semi-transmissive LCD	
	Number of dots	112×64 dots	
	Back light	Available	
Operating section	Key type	18 keys	
Indication LED	Tri-colored emitting elements (red/green/blue)		
Buzzer	Adjustable volume/tone		
Bluetooth	Specification	Bluetooth Ver1.2	HCI module produced by Kyocera
	Installed profile	SPP	Stack produced by iAnywhere
	Frequency	2402MHz to 2480MHz	
	Transmission power	Class 2	
	Communication range	Perspective 10m	Communication range may differ due to the environments.
	Baud rate	115.2kbps	
	Antenna	1/4λ (surface mounted)	
IrDA	IrDA Ver1.2(physical layer compliant) Baud rate: Maximum 115.2Kbps		
Power supply	Main power	Lithium-ion secondary battery 1880mAh	
	Regular voltage	3.7V	
	How to charge	With a dedicated AC adapter or cradle	With a rubber pad for the jack part
	Charging time	With a dedicated AC adapter: about 4 hours and half	
		With a dedicated cradle: about 7 hours and half	
	Scanning frequency	Over 30,000 times	*1
	Up-time	25 hours	*2
	Backup battery	MS (Manganeese Silicon) lithium secondary battery 3.4mAh	Without full discharge
Data holding time	72 hours or less	After main battery has been discharged.	

Item	Specification		Remark
2D barcode scanning section (MDI-230x specification)	Scanning method	CMOS area sensor (black/white)	MSI-2305
	Number of effective pixel	900x512 pixels	
	Light source	White LED	
	Scanning angle range	Horizontal: 40° Vertical: 23°	
	Supported symbology	2D	PDF417, Micro PDF417, QR Code, Micro QR Code, Data Matrix (ECC 0-140, ECC200), Maxi Code(mode2~5), Aztec Code, EAN / UCC Composite bar code, Intelligent Mail Barcode, Japanese Postal, Postnet (US)
1D	WPC (EAN, JAN, UPC-A / UPC-E UPC-E1), Industrial 2 of 5, IATA, Interleaved 2 of 5, NW-7 (CODABAR), Code 39, Code 93, Code 128, GS1-128, Tri-Optic, MSI / Plessey, UK / Plessey, TELEPEN, S-Code, Code 11, Matrix2 of 5, Korean Postal Authority code, CODABLOCK F, GS1 DataBar		
Dimensions	140×44×26mm		
Weight	Max. 132g (including lithium-ion battery pack)		
Conditions	Operation temperature and humidity	-10°C to 40°C 20%RH to 85%RH	No frost, no condensation
	Storage temperature and humidity	-20°C to 60°C 20%RH~85%RH	No frost, no condensation
	Charging temperature	0 to 40°C	
Drop test *4	Frequency	6sides, 3cycles	
	Height	150cm	
	Floor	Concrete	
Dust and drip proof	IP42		
Regulatory compliance	IEC 60825-1:2007 Class 1 CE Marking, FCC Bluetooth logo certification		
Accessories	Dedicated lithium-ion battery (1880mAh) Hand strap User's manual		

Item	Specification	Remark
Option	Dedicated cradle	For IrDA communication / charging
	Dedicated AC adapter [6V/2000mA]	For charging

*1 when scanning a barcode once per second at room temperature + frequency of connecting to Bluetooth.

*2 when scanning a barcode twice in 10 seconds at room temperature + frequency of connecting to Bluetooth.

*3 Shock resistance

Conditions of the shock resistance test are:

- Does not count scratches or whitening on a surface as a malfunction.
- Shock resistance is approved when no malfunction occurs after the test.
- Shock resistance is approved if the battery cover is not unhooked after the test

5. Optical Specifications

Item	Specifications	Unit
Scanning method	CMOS area sensor	-
Scanning speed	80	fps
Effective pixels	900(H) × 512(V)	Pixel
Aiming LED color temperature (White LED x 2)	8200	K
Scan angle	Horizontal: 40 Vertical: 23	deg

6. Technical Specifications

The conditions for technical specifications are as follows, unless otherwise specified in each section.

Conditions

Item	Conditions
Ambient temperature and humidity	Room temperature and humidity
Ambient light	1,000 to 1,500 lx (barcode surface)
Light source	3 wave lengths inverter fluorescent
Angles	$\alpha = 0^\circ$ $\beta = +15^\circ$ $\gamma = 0^\circ$
Curvature	$R = \infty$
Power supply voltage	3.3V
Decoding test	Approve the performance when decoding is successful in 70% of ten tests performed.
Barcode sample	As specified below

<Bar Code>

Resolution	Barcode	PCS	Size [mm]	Digit
0.254mm	Code 39	0.9	14×10	2
0.1mm	Code 39	0.9	11×10	4
0.26mm	JAN-13	0.9	25×19	13
0.26 mm	JAN- 8	0.9	17.5×15.5	8

Barcode sample: OPTOELECTRONICS test sample – Resolution = 0.127mm

or

OPTOELECTRONICS test sample – Resolution = 0.26mm

N:W ratio = 1:2.5

<PDF417>

Resolution	Error correction	PCS	Size [mm]	Number of character
0.339mm	Level-4	0.9	35×22	17
0.254mm	Level-4	0.9	26×16	17
0.127mm	Level-4	0.9	13×8	17

Barcodes printed by a normal printer – aspect ratio = 3 : 1

<QR Code (Model-2)>

Resolution	Error correction	PCS	Size [mm]	Number of character
0.339mm	M	0.9	10×10	44
0.169mm	M	0.9	5×5	44

Barcodes printed by a normal printer

<Data Matrix>

Resolution	Error correction	PCS	Size [mm]	Number of character
0.339mm	ECC200	0.9	8×8	40
0.169mm	ECC200	0.9	4×4	40

Barcodes printed by a normal printer

*As for the size of each barcode, quiet zone length is excluded.

6.1. Decode Depth of Field and Resolution

The depth of decode field is measured from the case front the data collector.

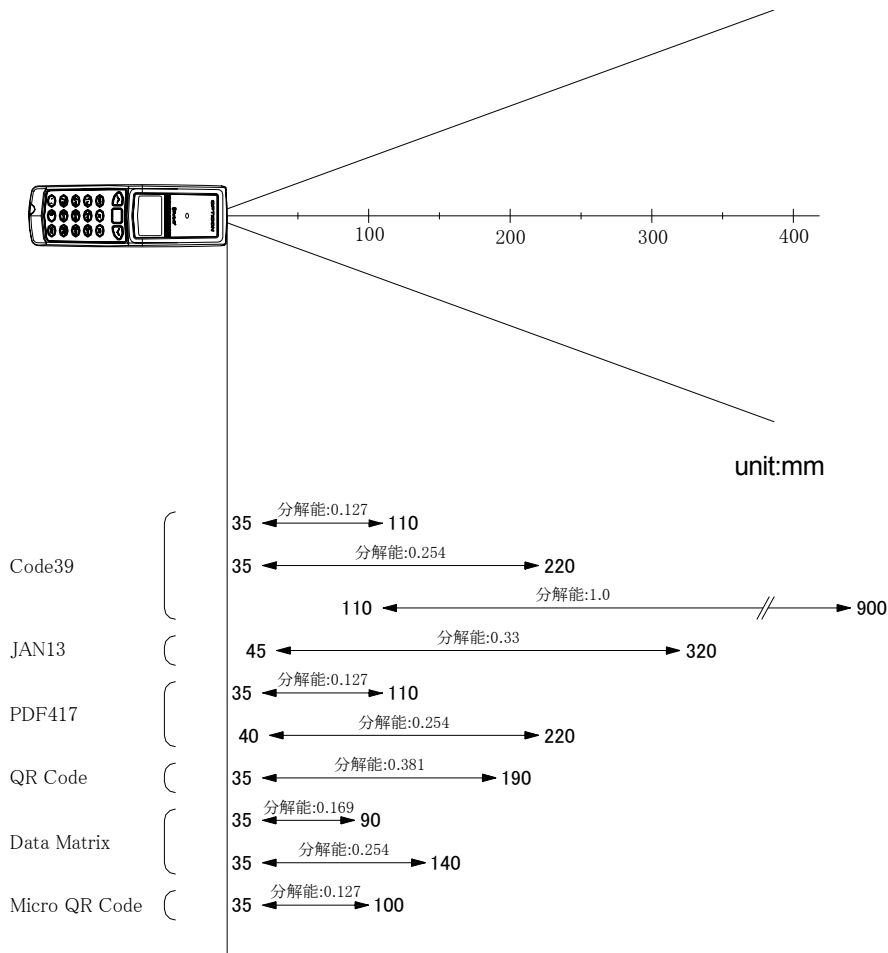

Figure3: Scanning field

6.2. Printed Contrast Signal

0.45 (MRD 32%) or higher (over 70% of reflectivity of space and)

*Scanning performance may decline if dirt or scratches mar the optical window. Keep the optical window clean.

6.3. Pitch, skew and tilt

Pitch angle: $\alpha = \pm 50^\circ$

Skew angle $\beta = \pm 60^\circ$

Tilt angle: $\gamma = 360^\circ$

Conditions:

Barcode sample: Code39, PDF417, Resolution 0.254mm, PCS0.9 as specified in the section 6.

Distance: 63mm from the focal plane of the data collector

Curvature: $R = \infty$

(For pitch/tilt angles, skew angle $\beta = +15^\circ$)

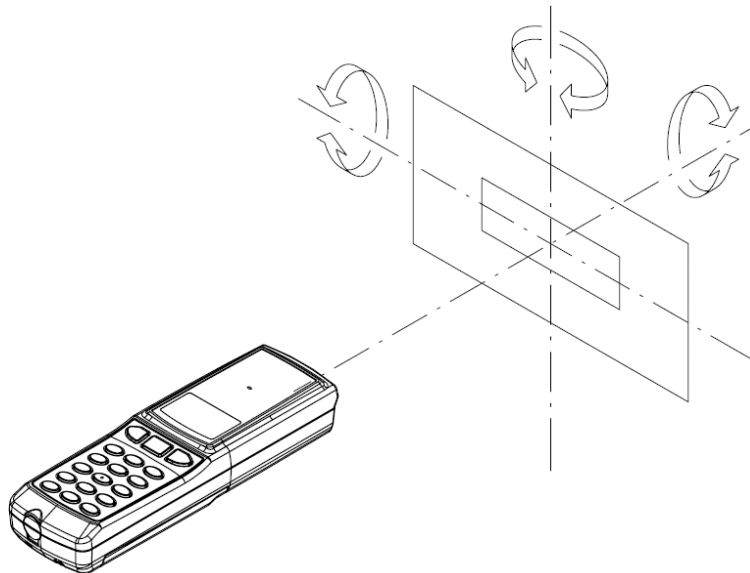

Figure4: Pitch, skew and tilt

*When scanning symbologies printed on highly glazed paper such as glossy paper or card case, scanning performance of this data collector may decline due to the specular reflection of LEDs. In such cases, adjust scanning angle by incline the data collector to 15 degrees toward the skew direction to improve scanning performance. When turning off the lighting LED, it may decline the scanning performance unless the ambient light is 1000 lx or higher. Also, the light or reflection light caught by the camera may decline scanning performance, when using codes on the above described paper.

6.4. Curvature

With 8-digit JAN barcode, decoding performance is guaranteed when $R \geq 15$ mm.

With 13-digit JAN barcode, decoding performance is guaranteed when $R \geq 20$ mm.

Conditions

Barcode sample: Code 39, PDF417, Resolution 0.254mm, PCS0.9 as specified in the section 6.

Distance: 63mm from the focal plane of the data collector

Curvature: $R = \infty$

(For pitch/tilt angles, skew angle $\beta = +15^\circ$)

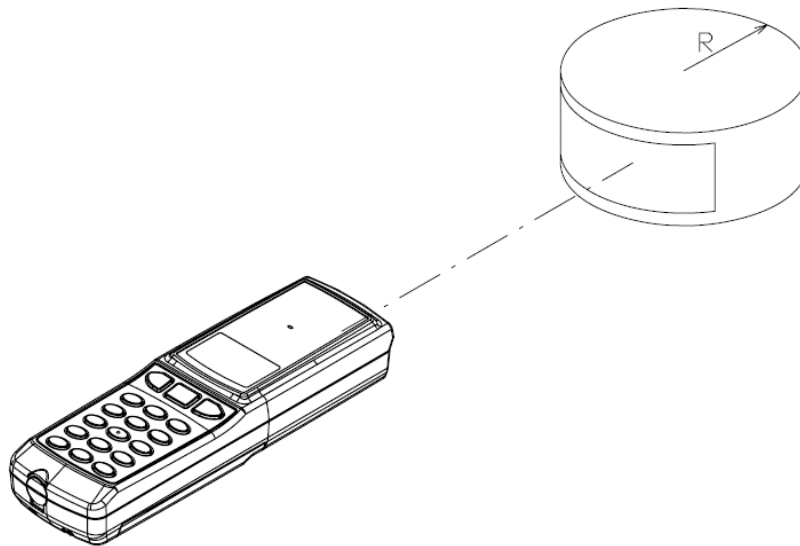

Figure5: Curvature

7. Bluetooth

Bluetooth wireless communication is used as a wireless interface.

7.1. Installed Profile

SPP(Serial Port Profile)

7.2. Communication Configuration

1 to 1 (One data collector to one host system)

7.3. Operating Mode While Connected to the Host System

Master / slave mode (*1)

*1 It can be set by the application software.

7.4. Security Mode

Authentication enabled

7.5. Encryption

Encryption enabled

8. Serial Label

The labels shown below are affixed to the data collector.

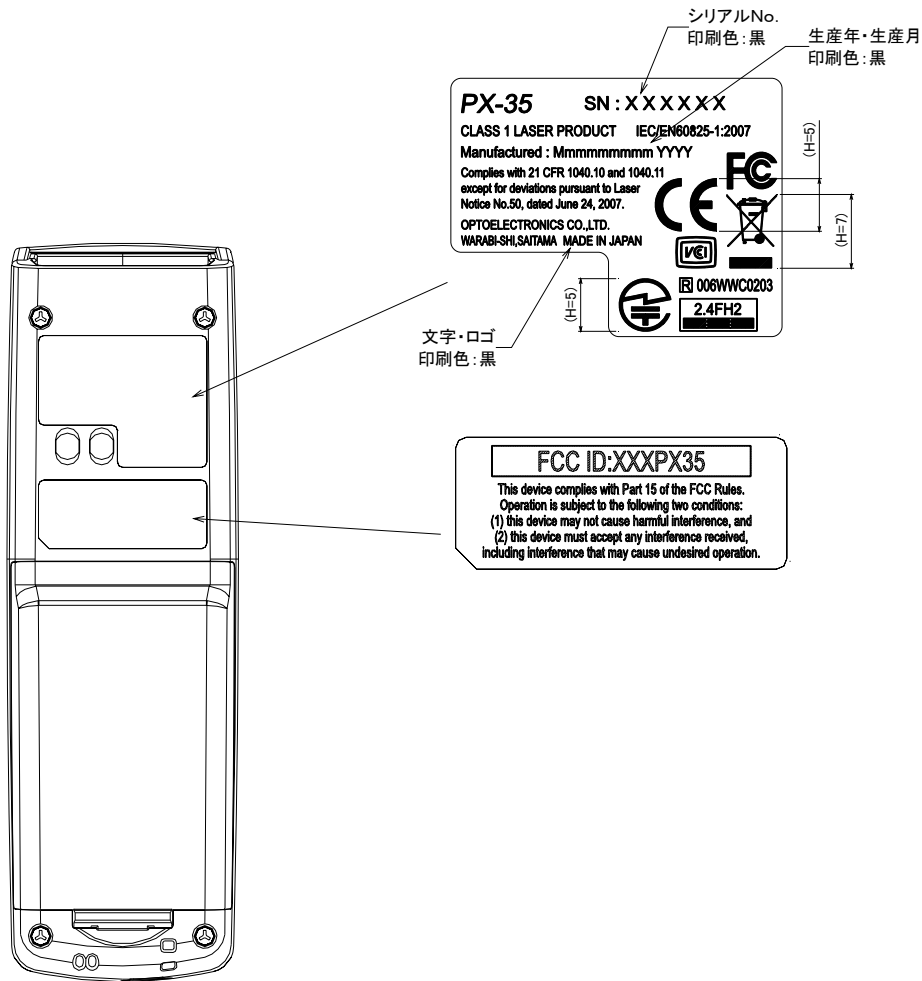

Figure 7: Serial label and FCC caution label

9. Packaging Specifications

9.1. Individual Packaging Specification

Put the data collector in a protective foam bag and place it in an individual packing box.

Size of the package (after assembly) 255(W) × 120(D) × 105(H) mm
 Refer to Appendix 1.

9.2. Collective Packaging Specification

Refer to Appendix 2.

Note: The “RO” mark labeled on the package tray or package box guarantees that the applicable product has passed our test of RoHS restrictions compliance (the restriction of the use of certain hazardous substances in electrical and electronic equipment, 2002/95 EC). However, this document does **not** have any legal weight in the European Union.

10. Durability

10.1. Ambient Light Immunity

Decoding performance is guaranteed when the range of illumination on a barcode surface is between zero and the following values:

Incandescent light	10,000 lx
Fluorescent light	10,000 lx
Sunlight	1000,000 lx

Conditions

Barcode sample: Code39, Resolution 0.254mm, PCS0.9 as specified in the section 6.

Distance: 63mm from the focal plane of the data collector

Angles: $\alpha = 0^\circ$, $\beta = +15^\circ$, $\gamma = 0^\circ$

Curvature: $R = \infty$

* Direct light or specular reflection from a light source should be prevented from entering the acceptance area.

10.2. Dust and Drip Proof

IP42

10.3. Vibration Strength (without packaging)

No malfunction occurred after the following test.

Vibration test: Increase the frequency of the vibration from 10Hz to 100 Hz with accelerated velocity $19.6\text{m}^2/\text{s}$ (2G) for 60 minutes in non-operating state

Repeat this routine in each X, Y, Z direction once for 60 minutes each.

10.4. Vibration Strength (with individual packaging)

No malfunction occurred after the following test.

Vibration test: Increase the frequency of the vibration from 10Hz to 100 Hz with accelerated velocity $19.6\text{m}^2/\text{s}$ (2G) for 60 minutes in individually packaged state. Repeat this routine in each X, Y, Z direction once for 60 minutes each.

10.5. Drop Test (without packaging)

No malfunction occurred after the following test.

Drop test: Drop the data collector from a height of 150cm onto a concrete floor. (Three times in each of 6 angles)

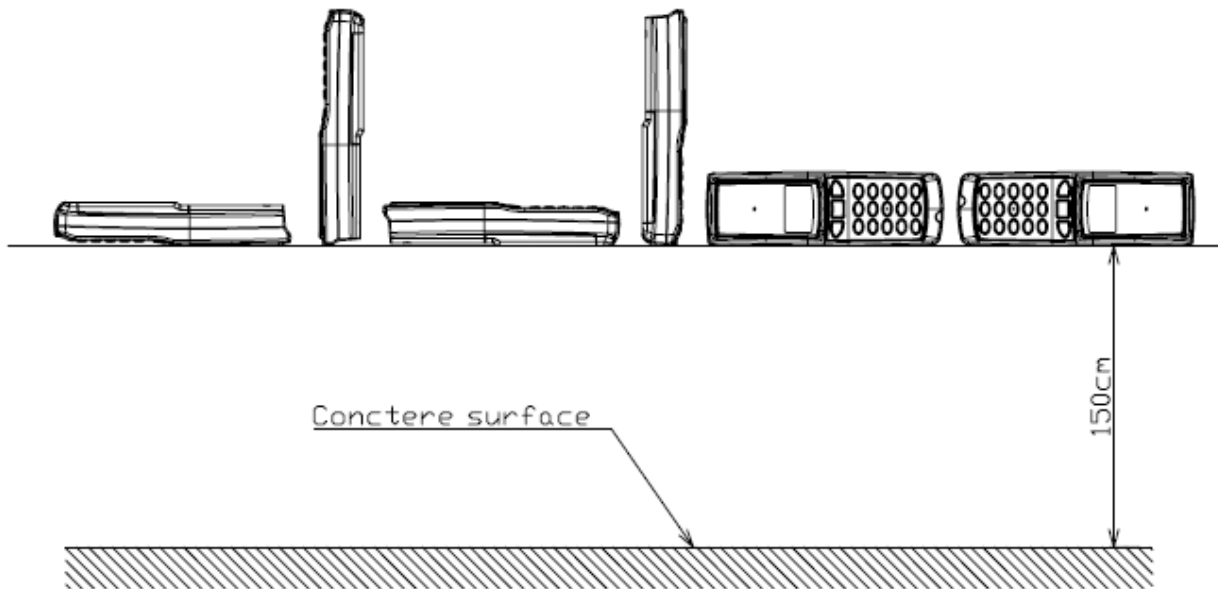

Figure 9: Drop Test (without packaging)

10.6. Drop Test (with individual packaging)

No malfunction occurred after the following test.

Drop test: Drop an individually packaged data collector from a height of 70cm onto a concrete floor once on its 1 corner, 3edges, and 6 sides. (10 total drop tests)

10.7. Static Electricity

Air discharge:	±10 kV max. (No malfunction) ±15 kV max. (No destruction)
Contact discharge:	±6 kV max. (No malfunction) ±10 kV max. (No destruction)
Measurement environment:	Use electrostatic testing device compliant with IEC 61000-4-2.
Discharge resistance:	330 Ω
Capacitor charging:	150 pF

10.8. Reliability

MTBF 10,000 hours

11. Warranty

11.1. Warranty Period

Optoelectronics Co., Ltd. (hereinafter 'Optoelectronics') warrants that this product is free of defects and malfunctions for a period of 12 (twelve) months beginning on the last day of the month in which it is shipped. Optoelectronics will repair product defects or malfunctions that arise in the course of normal usage during the twelve-month warranty period free of charge.

Any repair or replacement of the product after the foregoing warranty period will be charged at regular rates.

Repair or replacement of the product due to defects or malfunctions that arise as a result of customer mishandling will be charged at regular rates, even during the foregoing warranty period.

11.2. Delivery

Products for maintenance or repair shall be sent back to Optoelectronics. The sender is responsible for all shipping costs.

11.3. Repair Timeframe

Repaired products shall be shipped back to the customer within 20 days after acceptance by OPTOELECTRONICS. However, the time needed for the repair of products with early failures need to be separately discussed with Optoelectronics.

Expedited repairs may be available, subject to terms agreed to by OPTOELECTRONICS and the customer.

11.4. Maintenance Period

The maintenance period of this product is 5 years after its shipment.

OPTOELECTRONICS may discontinue maintenance for this product during the 5-year maintenance period if a satisfactory replacement product or maintenance solution is agreed to.

11.5. Others

Any additional warranty issues must be discussed with OPTOELECTRONICS on a case-by-case basis.

12. Regulatory Compliance

12.1. LED Safety

Lamp classification: IEC62471:2006 Exempt Group

12.2. LASER Safety

- IEC 60825-1:2007 Class 1
- CDRH Class I

12.3. Product Safety

- IEC60950-1
- EN60950-1

12.4. EMC

- EN55022
- EN55024
- FCC Part15 subpart B Class B

This device complies with part 15 of the FCC Rules. Operation is subject to the following two conditions :

- (1) this device may not cause harmful interference, and
- (2) this device must accept any interference received, including interference that may cause undesired operation.

- FCC Part15 subpart C

Federal Communications Commission Notices

This product complies with Part 15 of the FCC Rules. Operation is subject to the following two conditions:

- (1) this device may not cause harmful interference, and
- (2) this device must accept any interference received, including interference that may cause undesired operation.

Harmful Interference Notice

This product has been tested and complies with the specifications for a Class B digital device, pursuant to Part 15 of the FCC Rules. These limits are designed to provide reasonable protection against harmful interference in a residential installation. This equipment generates, uses, and can radiate radio frequency energy and, if not installed and used according to the instructions, may cause harmful interference to radio communications. However, there is no guarantee that interference will not occur in a particular installation. If this equipment does cause harmful interference to radio or television reception, which is found by turning the equipment off and on, the user is encouraged to try to correct the interference by one or more of the following measures:

- Reorient or relocate the receiving antenna
- Increase the separation between the equipment or devices
- Connect the equipment to an outlet other than the receiver's
- Consult a dealer or an experienced radio/TV technician for assistance

Changes or modifications to this equipment that have not been approved by Ruckus Wireless may void the user's authority to operate this equipment.

This equipment complies with FCC RF radiation exposure limits set forth for an uncontrolled environment.

- VCCI Class B

This is a Class B product, to be used in a domestic environment, based on the Technical Requirement of the Voluntary Control Council for Interference from Information Technology Equipment (VCCI). If this is used near a radio or television receiver in a domestic environment, it may cause radio interference.

12.5. R&TTE

- EN300 328
- EN301 489-1
- EN301 489-17

12.6. Others

- Certification for Construction Design of Specified Radio Equipment
- Bluetooth logo certification

13. RoHS

RoHS: The restriction of the use of certain hazardous substances in electrical and electronic equipment, 2002/95 EC.

14. Precautions

14.1. Precaution about the LED Light

Do not stare into the laser light from a scanning window. It may harm your eyes.

Caution - Use of controls or adjustments or performance of procedures other than those specified herein may result in hazardous radiation exposure.

14.2. Radio Low

The data collector has obtained the Certification for Construction Design of Specified Radio Equipment.

Therefore it does not need to have a radio station license in Japan.

The following activities are prohibited under the Radio Law:

- Remodeling and disassembly
- Peeling off the certificate label

Do NOT use the data collector under the following environment:

*Otherwise radio interference may affect other device and end up with causing physical or material damage.

- Safety apparatus and medical device for human body protection
- Environment where is concerned to cause serious damage

14.3. Handling

Handle this product carefully. Do not deliberately subject it to any of the following.

(1) Shock

- Do not drop from the non-standard height.
- Do not place any heavy items on the data collector.
- Do not squeeze it between any heavy items.
- Do not swing around the cable.

(2) Temperature Conditions

- Do not use the data collector at temperatures outside the specified range.
- Do not pour boiling water on the data collector.
- Do not throw the data collector into the fire.

(3) Foreign Materials

- Do not put the data collector into liquid.
- Do not put the data collector into chemicals.

(4) Others

- Do not disassemble this product.
- Do not use the data collector near a radio or a TV receiver. It may cause reception problems.
- The data collector may be damaged by voltage drops caused by lightning.
- The data collector may not perform properly in environments when placed near a flickering light, such as a CRT

14.4. Export Administration Regulations

This product is subject to the strategically controlled exports regulated under “Foreign Exchange and Foreign Trade Laws”. Therefore, export of this product may require an export permission of Japanese government.

14.5. Bluetooth

To communicate via Bluetooth, the device which PX-35 is connected to must support the same Bluetooth version and profile as PX-35's.

- PX-35 is compliant to Bluetooth standards. However, we cannot assure the connection between PX-35 and other Bluetooth devices which have not been tested.
- Bluetooth supporting devices use 2.4 GHz frequency band. However, many other sorts of devices also utilize this frequency band. It may effect the communication speed or communication range of this data collector.
- The use of PX-35 outside of the European Union, the United States and Canada is punishable under the law.
- Communication speed and communication range of PX-35 may differ due to the obstacles and radio wave conditions between PX-35 and the device, which PX-35 is connected to.
- Conditions of the device, which PX-35 is connected to, may also affect the communication speed and communication range of PX-35.

14.6. Frequency Band

The frequency band 2.4 GHz is utilized by this scanner. Read carefully the followings before using this product.

In the frequency band of this scanner, scientific, medical and industrial devices including microwaves are used. Also other radio stations including local private radio station for mobile object identification requiring license for such as manufacturing lines at factories, specific power-saving radio station requiring no license and amateur radio station are managed.

Please make sure that "other radio stations" are not managed in the frequency band 2.4 GHz before using this scanner.

In case that radio interference occurs between this scanner and "other radio stations," change the service space immediately, or stop transmitting radio wave to avoid the interference.

If you have any questions or troubles, please contact our marketing group.

Appendix 1

Individual Packaging Specification

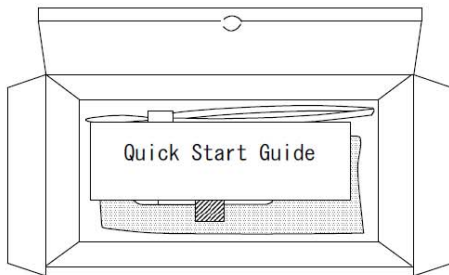
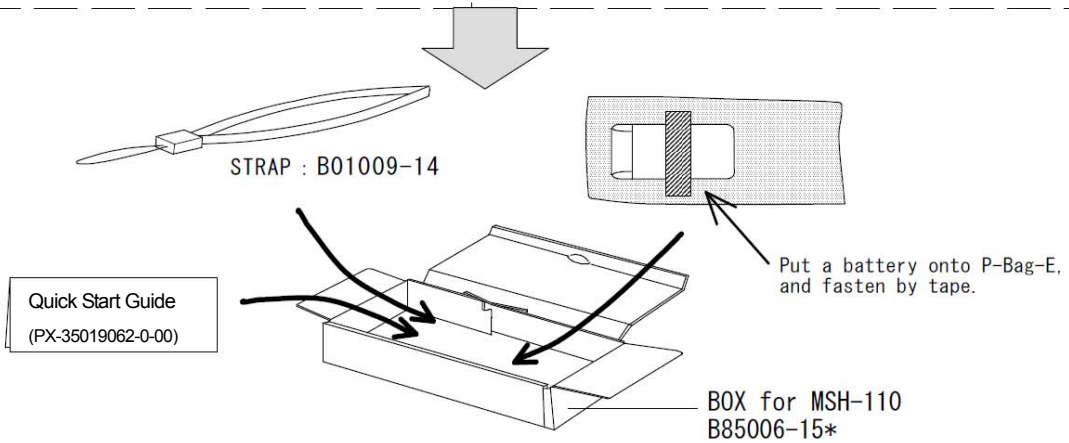
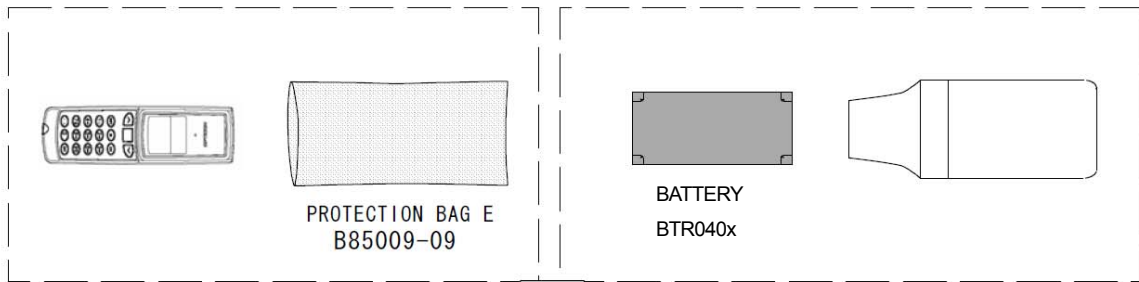

Display for the serial-No.
 from 『 000001 』 to 『 099999 』
 Same number as the scanner.
 Number of six digits.
 *Continuous Number.

BAR CODE LABEL for BOX
 (3A0002)

Diagram showing the bar code label being applied to the corner of the box.

Model No.	PX-35	MADE IN	△△△△
Spec No.	 <small>* X F 1 P X 3 5 *</small>		
Serial No.	 <small>* △ △ △ △ △ △ *</small>		
Quantity	1		

Ro

Do not fold at the Bar-Code Position, when stick the Label on to the Corner of Box.

Appendix 2

Collective Packaging Specification

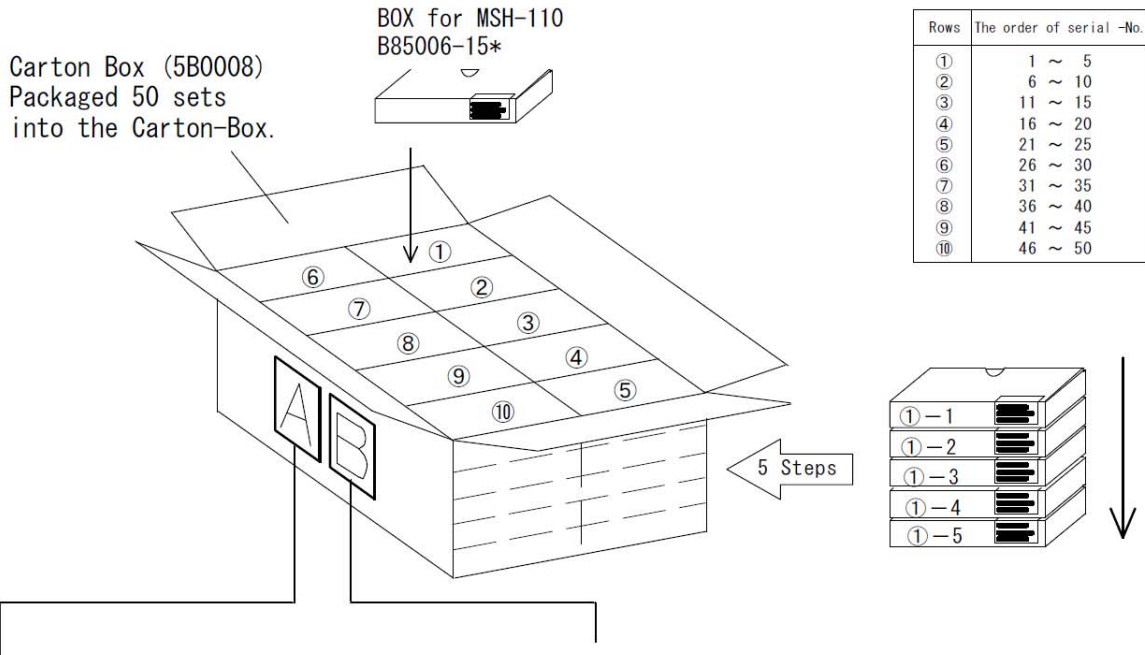

A : Barcode Serial Label for Packaging Box:
Stick the labels on both front and back side of the box.

B : Missing Serial Number Label:
Attach this label when there are more than 3 labels of which serial numbers are out of order (not in a correct sequence).



(3C0006)



(3C0007)

C/No. $\triangle\triangle$
MADE IN $\triangle\triangle\triangle\triangle$

Product **PX-35**

Spec#JPN 
* X F 1 P X 3 5 *

Q'ty  * $\triangle\triangle$ * S/N (from)  *000001*
 $\triangle\triangle/\triangle\triangle\triangle$ S/N (to)  *000 $\triangle\triangle\triangle$ *











Missing Serial Number	Missing Q'ty \triangle
1	 * $\triangle\triangle\triangle\triangle\triangle$ *
2	 * $\triangle\triangle\triangle\triangle\triangle$ *

ROM-Ver. FM42J $\triangle\triangle$ 

Shipping Date 20 $\triangle\triangle$ / $\triangle\triangle$ / $\triangle\triangle$

OPTOELECTRONICS CO.,LTD.

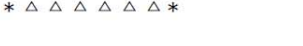
C/No. $\triangle\triangle$
MADE IN $\triangle\triangle\triangle\triangle$

Missing Serial Number	Missing Q'ty $\triangle\triangle$
3	 * $\triangle\triangle\triangle\triangle\triangle\triangle$ *
4	 * $\triangle\triangle\triangle\triangle\triangle\triangle$ *
5	 * $\triangle\triangle\triangle\triangle\triangle\triangle$ *
6	 * $\triangle\triangle\triangle\triangle\triangle\triangle$ *
7	 * $\triangle\triangle\triangle\triangle\triangle\triangle$ *
8	 * $\triangle\triangle\triangle\triangle\triangle\triangle$ *
9	 * $\triangle\triangle\triangle\triangle\triangle\triangle$ *
10	 * $\triangle\triangle\triangle\triangle\triangle\triangle$ *
11	 * $\triangle\triangle\triangle\triangle\triangle\triangle$ *
12	 * $\triangle\triangle\triangle\triangle\triangle\triangle$ *

OPTOELECTRONICS CO., LTD.