

# ONKYO

CD Receiver System

# CS-355

CD Receiver (CR-245BT)  
Speakers (D-T05)

## Instruction Manual

Thank you for purchasing an Onkyo CD Receiver System. Please read this manual thoroughly before making any connections and plugging it in. Following the instructions in this manual will enable you to obtain optimum performance and listening enjoyment from your new CD Receiver System. Please retain this manual for future reference.

**Getting Started ..... 2**

**Connections ..... 13**

**Basic Operations ..... 17**

**Playing CDs ..... 19**

**Playing Your iPod/iPhone/iPad ..... 22**

**Playing Back via Bluetooth ..... 23**

**Listening to the Radio ..... 24**

**Playing a USB Flash Drive ..... 26**

**Clock and Timer ..... 26**

**Miscellaneous ..... 29**



ENTERTAINMENT

**WARNING:**

TO REDUCE THE RISK OF FIRE OR ELECTRIC SHOCK, DO NOT EXPOSE THIS APPARATUS TO RAIN OR MOISTURE.

**CAUTION:**

TO REDUCE THE RISK OF ELECTRIC SHOCK, DO NOT REMOVE COVER (OR BACK). NO USER-SERVICEABLE PARTS INSIDE. REFER SERVICING TO QUALIFIED SERVICE PERSONNEL.



**WARNING**  
RISK OF ELECTRIC SHOCK  
DO NOT OPEN

**AVIS**  
RISQUE DE CHOC ELECTRIQUE  
NE PAS OUVRIR



The lightning flash with arrowhead symbol, within an equilateral triangle, is intended to alert the user to the presence of uninsulated "dangerous voltage" within the product's enclosure that may be of sufficient magnitude to constitute a risk of electric shock to persons.



The exclamation point within an equilateral triangle is intended to alert the user to the presence of important operating and maintenance (servicing) instructions in the literature accompanying the appliance.

## Important Safety Instructions

1. Read these instructions.
2. Keep these instructions.
3. Heed all warnings.
4. Follow all instructions.
5. Do not use this apparatus near water.
6. Clean only with dry cloth.
7. Do not block any ventilation openings. Install in accordance with the manufacturer's instructions.
8. Do not install near any heat sources such as radiators, heat registers, stoves, or other apparatus (including amplifiers) that produce heat.
9. Do not defeat the safety purpose of the polarized or grounding-type plug. A polarized plug has two blades with one wider than the other. A grounding type plug has two blades and a third grounding prong. The wide blade or the third prong are provided for your safety. If the provided plug does not fit into your outlet, consult an electrician for replacement of the obsolete outlet.
10. Protect the power cord from being walked on or pinched particularly at plugs, convenience receptacles, and the point where they exit from the apparatus.
11. Only use attachments/accessories specified by the manufacturer.
12. Use only with the cart, stand, tripod, bracket, or table specified by the manufacturer, or sold with the apparatus. When a cart is used, use caution when moving the cart/apparatus combination to avoid injury from tip-over.
 

PORTABLE CART WARNING



S3125A
13. Unplug this apparatus during lightning storms or when unused for long periods of time.
14. Refer all servicing to qualified service personnel. Servicing is required when the apparatus has been damaged in any way, such as power-supply cord or plug is damaged, liquid has been spilled or objects have fallen into the apparatus, the apparatus has been exposed to rain or moisture, does not operate normally, or has been dropped.
15. Damage Requiring Service
 

Unplug the apparatus from the wall outlet and refer servicing to qualified service personnel under the following conditions:

  - A. When the power-supply cord or plug is damaged,
  - B. If liquid has been spilled, or objects have fallen into the apparatus,
  - C. If the apparatus has been exposed to rain or water,
  - D. If the apparatus does not operate normally by following the operating instructions. Adjust only those controls that are covered by the operating instructions as an improper adjustment of other controls may result in damage and will often require extensive work by a qualified technician to restore the apparatus to its normal operation,
  - E. If the apparatus has been dropped or damaged in any way, and
  - F. When the apparatus exhibits a distinct change in performance this indicates a need for service.
16. Object and Liquid Entry
 

Never push objects of any kind into the apparatus through openings as they may touch dangerous voltage points or short-out parts that could result in a fire or electric shock.

The apparatus shall not be exposed to dripping or splashing and no objects filled with liquids, such as vases shall be placed on the apparatus.

Don't put candles or other burning objects on top of this unit.
17. Batteries
 

Always consider the environmental issues and follow local regulations when disposing of batteries.
18. If you install the apparatus in a built-in installation, such as a bookcase or rack, ensure that there is adequate ventilation.
 

Leave 20 cm (8") of free space at the top and sides and 10 cm (4") at the rear. The rear edge of the shelf or board above the apparatus shall be set 10 cm (4") away from the rear panel or wall, creating a flue-like gap for warm air to escape.

# Precautions

1. **Recording Copyright**—Unless it's for personal use only, recording copyrighted material is illegal without the permission of the copyright holder.
2. **AC Fuse**—The AC fuse inside the unit is not user-serviceable. If you cannot turn on the unit, contact your Onkyo dealer.
3. **Care**—Occasionally you should dust the unit all over with a soft cloth. For stubborn stains, use a soft cloth dampened with a weak solution of mild detergent and water. Dry the unit immediately afterwards with a clean cloth. Don't use abrasive cloths, thinners, alcohol, or other chemical solvents, because they may damage the finish or remove the panel lettering.
4. **Power**

## WARNING

BEFORE PLUGGING IN THE UNIT FOR THE FIRST TIME, READ THE FOLLOWING SECTION CAREFULLY.

AC outlet voltages vary from country to country. Make sure that the voltage in your area meets the voltage requirements printed on the unit's rear panel (e.g., AC 230 V, 50 Hz or AC 120 V, 60 Hz).

The power cord plug is used to disconnect this unit from the AC power source. Make sure that the plug is readily operable (easily accessible) at all times.

For models with [POWER] button, or with both [POWER] and [ON/STANDBY] buttons:

Pressing the [POWER] button to select OFF mode does not fully disconnect from the mains. If you do not intend to use the unit for an extended period, remove the power cord from the AC outlet.

For models with [ON/STANDBY] button only:

Pressing the [ON/STANDBY] button to select Standby mode does not fully disconnect from the mains. If you do not intend to use the unit for an extended period, remove the power cord from the AC outlet.

5. **Preventing Hearing Loss**

## Caution

Excessive sound pressure from earphones and headphones can cause hearing loss.

6. **Batteries and Heat Exposure**

## Warning

Batteries (battery pack or batteries installed) shall not be exposed to excessive heat as sunshine, fire or the like.

7. **Never Touch this Unit with Wet Hands**—Never handle this unit or its power cord while your hands are wet or damp. If water or any other liquid gets inside this unit, have it checked by your Onkyo dealer.

8. **Handling Notes**

- If you need to transport this unit, use the original packaging to pack it how it was when you originally bought it.
- Do not leave rubber or plastic items on this unit for a long time, because they may leave marks on the case.

- This unit's top and rear panels may get warm after prolonged use. This is normal.
- If you do not use this unit for a long time, it may not work properly the next time you turn it on, so be sure to use it occasionally.
- When you've finished using this unit, remove all discs and turn off the power.

9. **Installing this Unit**

- Install this unit in a well-ventilated location.
- Ensure that there's adequate ventilation all around this unit, especially if it's installed in an audio rack. If the ventilation is inadequate, the unit may overheat, leading to malfunction.
- Do not expose this unit to direct sunlight or heat sources, because its internal temperature may rise, shortening the life of the optical pickup.
- Avoid damp and dusty places, and places subject to vibrations from loudspeakers. Never put the unit on top of, or directly above a loudspeaker.
- Install this unit horizontally. Never use it on its side or on a sloping surface, because it may cause a malfunction.
- If you install this unit near a TV, radio, or VCR, the picture and sound quality may be affected. If this occurs, move this unit away from the TV, radio, or VCR.

10. **Moisture Condensation**

## Moisture condensation may damage this unit.

Read the following carefully:

Moisture may condense on the lens of the optical pickup, one of the most important parts inside this unit.

- Moisture condensation can occur in the following situations:
  - The unit is moved from a cold place to a warm place.
  - A heater is turned on, or cold air from an air conditioner is hitting the unit.
  - In the summer, when this unit is moved from an air conditioned room to a hot and humid place.
  - The unit is used in a humid place.
- Do not use this unit when there's the possibility of moisture condensation occurring. Doing so may damage your discs and certain parts inside this unit.

If condensation does occur, unplug the power cord and leave the unit for two to three hours in the room temperature.

This unit contains a semiconductor laser system and is classified as a "CLASS 1 LASER PRODUCT". So, to use this model properly, read this Instruction Manual carefully. In case of any trouble, please contact the store where you purchased the unit.

To prevent being exposed to the laser beam, do not try to open the enclosure.

## CAUTION:

CLASS 1M VISIBLE AND INVISIBLE LASER RADIATION WHEN OPEN. DO NOT VIEW DIRECTLY WITH OPTICAL INSTRUMENTS.

## Precautions—Continued

THIS PRODUCT UTILIZES A LASER. USE OF CONTROLS OR ADJUSTMENTS OR PERFORMANCE OF PROCEDURES OTHER THAN THOSE SPECIFIED HEREIN MAY RESULT IN HAZARDOUS RADIATION EXPOSURE.

The label on the right is applied on the rear panel.



1. This unit is a CLASS 1 LASER PRODUCT and employs a laser inside the cabinet.
2. To prevent the laser from being exposed, do not remove the cover. Refer servicing to qualified personnel.

This transmitter must not be co-located or operated in conjunction with any other antenna or transmitter.

### For U.S. models

#### FCC Information for User

#### IMPORTANT NOTE:

This equipment complies with FCC/IC radiation exposure limits set forth for an uncontrolled environment and meets the FCC radio frequency (RF) Exposure Guidelines in Supplement C to OET65 and RSS-102 of the IC radio frequency (RF) Exposure rules. This equipment has very low levels of RF energy that it deemed to comply without maximum permissive exposure evaluation (MPE). But it is desirable that it should be installed and operated keeping the radiator at least 20 cm or more away from person's body (excluding extremities: hands, wrists, feet and ankles).

#### REMARQUE IMPORTANTE :

Cet équipement est conforme aux limites FCC/IC d'exposition aux rayonnements définies pour un environnement non réglementé, aux lignes directrices de la FCC en matière d'exposition aux radiofréquences (RF) spécifiées dans le supplément C du bulletin OET65 et aux réglementations RSS-102 de l'IC sur l'exposition aux radiofréquences (RF).

Cet équipement étant associé à de très faibles niveaux d'énergie radiofréquence, il est considéré conforme sans évaluation de l'exposition maximale admise (EMA). Il est cependant conseillé de l'installer et de l'utiliser en maintenant la source de rayonnement radioélectrique à 20 cm minimum du corps (à l'exclusion des extrémités du corps : les mains, les poignets, les pieds et les chevilles).

#### FCC Caution:

#### FCC WARNING

Changes or modifications not expressly approved by the party responsible for compliance could void the user's authority to operate the equipment.

#### NOTE:

This equipment has been tested and found to comply with the limits for a Class B digital device, pursuant to

Part 15 of the FCC Rules. These limits are designed to provide reasonable protection against harmful interference in a residential installation.

This equipment generates, uses and can radiate radio frequency energy and, if not installed and used in accordance with the instructions, may cause harmful interference to radio communications. However, there is no guarantee that interference will not occur in a particular installation. If this equipment does cause harmful interference to radio or television reception, which can be determined by turning the equipment off and on, the user is encouraged to try to correct the interference by one or more of the following measures:

- Reorient or relocate the receiving antenna.
- Increase the separation between the equipment and receiver.
- Connect the equipment into an outlet on a circuit different from that to which the receiver is connected.
- Consult the dealer or an experienced radio/TV technician for help.

### For Canadian Models

#### NOTE:

THIS CLASS B DIGITAL APPARATUS COMPLIES WITH CANADIAN ICES-003.

For models having a power cord with a polarized plug:

#### CAUTION:

TO PREVENT ELECTRIC SHOCK, MATCH WIDE BLADE OF PLUG TO WIDE SLOT, FULLY INSERT.

### Modèle pour les Canadiens

#### REMARQUE:

CET APPAREIL NUMÉRIQUE DE LA CLASSE B EST CONFORME À LA NORME NMB-003 DU CANADA.

Sur les modèles dont la fiche est polarisée:

#### ATTENTION:

POUR ÉVITER LES CHOCS ÉLECTRIQUES, INTRODUIRE LA LAME LA PLUS LARGE DE LA FICHE DANS LA BORNE CORRESPONDANTE DE LA PRISE ET POUSSER JUSQU'AU FOND.

This device complies with Industry Canada licence-exempt RSS standard(s). Operation is subject to the following two conditions: (1) this device may not cause interference, and (2) this device must accept any interference, including interference that may cause undesired operation of the device.

Le présent appareil est conforme aux CNR d'Industrie Canada applicables aux appareils radio exempts de licence. L'exploitation est autorisée aux deux conditions suivantes : (1) l'appareil ne doit pas produire de brouillage, et (2) l'utilisateur de l'appareil doit accepter tout brouillage radioélectrique subi, même si le brouillage est susceptible d'en compromettre le fonctionnement.

## Precautions—Continued

### Before Using Your New Speakers

- Place the speakers on sturdy, flat surfaces. Putting them on uneven or unstable surfaces where they may fall and cause damage will affect the sound quality.
- Do not keep water or other liquids close to the speakers. If a liquid is spilled over them, the woofer and tweeter inside may be damaged.
- Do not handle the speakers with wet or damp hands.

### Speaker Precautions

The speakers can handle the specified input power when used for normal music reproduction. If they're fed any of the following signals, even if the input power is within the specified rating, excessive current may flow in the speaker coils, causing burning or wire breakage:

1. Interstation noise from an untuned FM radio.
2. Audio from a cassette that's being fast-forwarded.
3. High-pitched sounds generated by an oscillator, electronic musical instrument, and so on.
4. Amplifier oscillation.
5. Special test tones from audio test CDs and so on.
6. Thumps and clicks caused by connecting or disconnecting audio cables (always turn off your amplifier before connecting or disconnecting cables).
7. Microphone feedback.

The speakers contain powerful magnets. Do not put metal items, such as screwdrivers, close to the speakers, as they may be attracted toward the magnet, causing injury, or damage to the tweeter diaphragm.

### Using Close to a TV or Computer

TVs and computer monitors are magnetically sensitive devices and as such are likely to suffer from discoloration or picture distortion when conventional speakers are placed nearby. To prevent this, the speakers feature internal magnetic shielding. In some situations, however, discoloration may still be an issue. In this case, turn off your TV or monitor, wait 15 to 30 minutes, and then turn it back on again. This normally activates the degaussing function, which neutralizes the magnetic field, thereby removing any discoloration effects. If discoloration problems persist, try moving the speakers away from your TV or monitor. Note that discoloration can also be caused by a magnet or demagnetizing tool that's too close to your TV or monitor.

#### Note:

- If the speakers are placed close to a TV or monitor, due to the electromagnetic waves radiated by the TV or monitor, you may hear noise from the speakers even after your amplifier has been turned off. To prevent this, position the speakers away from your TV or monitor.

Onkyo does not guarantee Bluetooth compatibility between the CR-245BT system and all Bluetooth-enabled devices.

For compatibility between the CR-245BT system and another device with Bluetooth technology, consult the device's documentation and dealer. In some countries, there may be restrictions on using Bluetooth devices. Check with your local authorities.

# Package Contents

Make sure you have the following items:

**CR-245BT**

**Remote controller (RC-854C)**

**Indoor FM antenna**

**AM loop antenna**

**Power cord**

(Connector type varies from country to country.)

**Speakers (D-T05)**

**Speaker cables**

**8 floor pads**

\* In catalogs and on packaging, the letter at the end of the product name indicates the color. Specifications and operation are the same regardless of color.

## Using the Included Floor Pads for speakers

You can improve the sound quality by attaching the included floor pads to raise the speakers off the surface and reduce the contact area. The floor pads also make the speakers stable and prevent them from slipping.

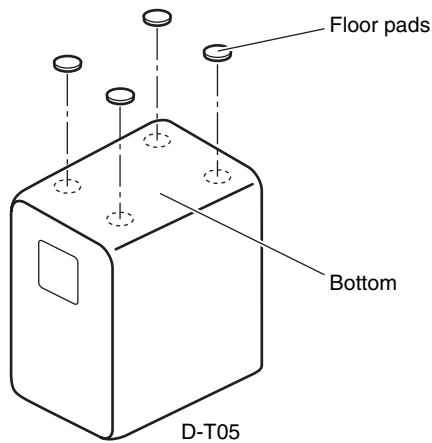

## Using the Remote Controller

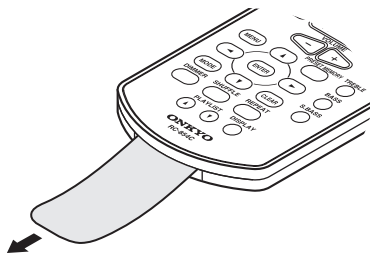

Remove the plastic film before using the remote controller.

When using the remote controller, point it toward the CD receiver's remote control sensor, as shown below.

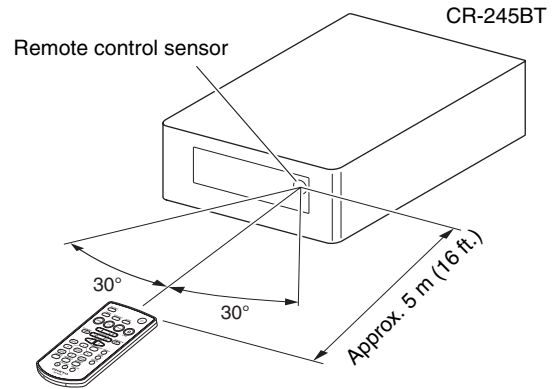

## Replacing the Battery

Use only a battery of the same type (CR2025).

Firmly insert a thin stick or similar object into the hole, and pull out firmly in the direction of the arrow.

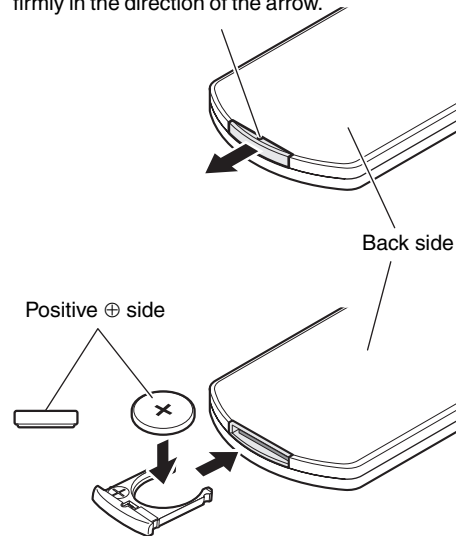

### Note:

- If the remote controller doesn't work reliably, try replacing the batteries.
- If you intend not to use the remote controller for a long time, remove the batteries to prevent damage from leakage or corrosion.
- Expired batteries should be removed as soon as possible to prevent damage from leakage or corrosion.

### Caution:

- Replacing the battery incorrectly may cause an explosion. Use only a battery of the same type or an equivalent.

# Features

## General

- Super Bass (S.Bass) function for deeper bass sounds
- Bass and treble tone controls
- Line input for external audio source
- AUDIO OUT (SUBWOOFER) jack
- Headphones jack
- Dimmable display

## Speakers

- Stylish cabinet
- 2 Way Bass-reflex

## iPod

- iPod/iPhone/iPad direct digital connection<sup>\*1</sup>
- Control your iPod/iPhone/iPad with the remote controller
- Made for iPod touch (1st, 2nd, 3rd and 4th generation), iPod nano (2nd, 3rd, 4th, 5th and 6th generation), iPhone, iPhone 3G, iPhone 3GS, iPhone 4, iPhone 4S, iPad, iPad 2, and iPad (3rd generation)

## Radio

- AM/FM tuner
- 30 AM/FM Presets
- FM Auto Preset function

## CD Player

- Play audio CDs, MP3 CDs (CD-R and CD-RW)
- RANDOM playback mode
- 2-mode repeat function (current track or all tracks)

## USB Flash Drive

- MP3 playback from USB flash drives

## Timer and Clock

- Programmable timer
- Sleep timer
- The alarm play function of the iPod/iPhone/iPad can power-on the CD receiver and switch the input to iPod/iPhone/iPad<sup>\*2</sup>

## Bluetooth

- Wireless Music Playback via Bluetooth<sup>\*3</sup>
- Profile: A2DP 1.2
- Audio codec: SBC, AAC and aptX<sup>\*4</sup>

\*1.



iPad, iPhone, iPod, iPod classic, iPod nano, iPod shuffle, and iPod touch are trademarks of Apple Inc., registered in the U.S. and other countries.

“Made for iPod”, “Made for iPhone” and “Made for iPad” mean that an electronic accessory has been designed to connect specifically to iPod, iPhone, or iPad, respectively, and has been certified by the developer to meet Apple performance standards. Apple is not responsible for the operation of this device or its compliance with safety and regulatory standards. Please note that the use of this accessory with iPod, iPhone or iPad may affect wireless performance.

\*2. This functionality might not be available depending on the iPod/iPhone/iPad model or apps.

\*3. The Bluetooth® word mark and logos are registered trademarks owned by Bluetooth SIG, Inc. and any use of such marks by Onkyo is under license. Other trademarks and trade names are those of their respective owners.

Please read rating label at the bottom of system for other safety information.



\*4. aptX is a registered trademark of CSR plc.

# Contents

<b>Getting Started</b>		<b>Playing Your iPod/iPhone/iPad</b>	
Important Safety Instructions.....	2	Playing Your iPod/iPhone/iPad.....	21
Precautions.....	3	Playing an iPod/iPhone/iPad via USB.....	21
Package Contents.....	6	Navigating the iPod Menus with the Remote Controller.....	21
Using the Included Floor Pads for speakers.....	6		
Using the Remote Controller.....	6		
Replacing the Battery.....	6		
Features.....	7		
Getting to Know the CD receiver.....	9		
Top and Front Panels.....	9		
Display.....	10		
Rear Panel.....	10		
Remote Controller.....	11		
Disc (Audio CD and MP3) and USB Flash Drive (MP3) Notes.....	12		
<b>Connections</b>		<b>Playing Back via Bluetooth</b>	
Connecting Speakers.....	13	Playing Back via Bluetooth.....	22
Connecting the Antennas.....	14	Listening to an audio from Bluetooth device.....	22
Connecting an Outdoor FM Antenna.....	14	Displaying Bluetooth Information.....	22
Connecting Other Components.....	15	Setting Bluetooth Standby.....	22
Connecting a Powered Subwoofer.....	15		
Connecting an Audio Playback Device.....	15		
Connecting the Power Cord.....	15		
<b>Basic Operations</b>		<b>Listening to the Radio</b>	
Basic Operations.....	16	Listening to the Radio.....	23
Turning On the CD receiver.....	16	Tuning into FM Radio Stations.....	23
Setting Auto Standby (ASb).....	16	Presetting FM Stations Automatically (Auto Preset).....	23
Selecting the Input Source.....	16	Presetting AM/FM Stations Manually.....	24
Adjusting the Volume.....	16	Selecting Preset Stations.....	24
Muting the CD receiver.....	16	Erasing Presets.....	24
Using Headphones.....	16		
Adjusting the Bass and Treble.....	17		
Using Super Bass.....	17		
Changing the Display Brightness.....	17		
<b>Playing CDs</b>		<b>Playing a USB Flash Drive</b>	
Playing CDs.....	18	Playing a USB Flash Drive.....	25
Playing CDs.....	18		
Displaying CD Information.....	18		
Selecting MP3 Files.....	19		
Displaying MP3 Information.....	19		
Random Playback.....	20		
Repeat Playback.....	20		
		<b>Clock and Timer</b>	
		Setting the Clock.....	25
		Setting the Clock.....	25
		Using the Timer.....	26
		Programming the Timer.....	26
		Turning Timer On and Off.....	27
		Using the Sleep Timer.....	27
		Timer Playback using the Alarm Play Function of your iPod.....	27
		<b>Miscellaneous</b>	
		Troubleshooting.....	28
		Specifications.....	32



# Getting to Know the CD receiver

## Top and Front Panels

### Top Panel

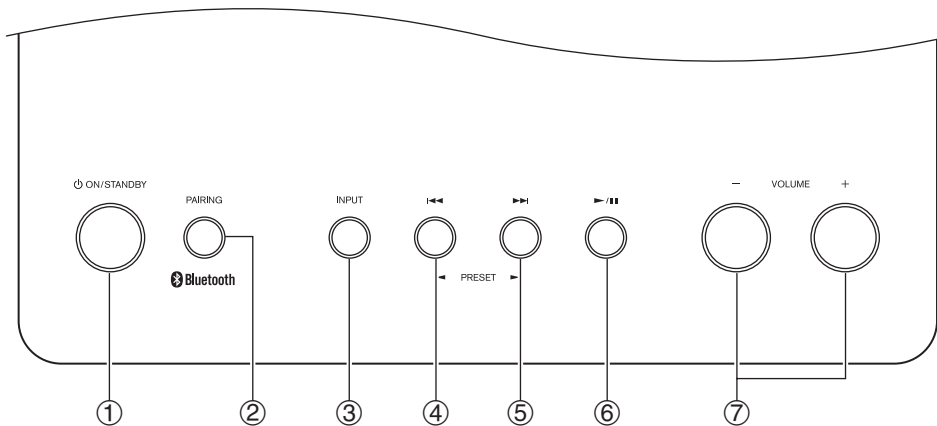

### Front Panel

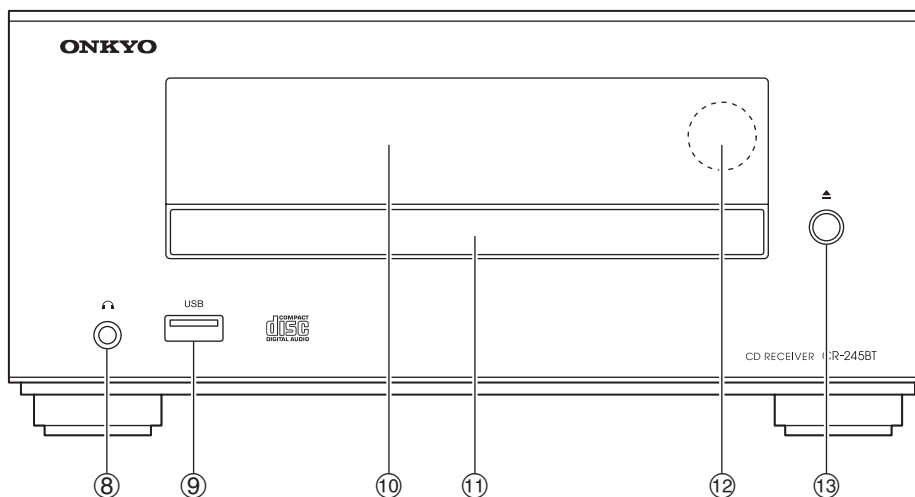

For detailed information, see the pages in parentheses.

- |   |                                     |
|---|-------------------------------------|
| ① <b>ON/STANDBY</b> button (17, 23, 27, 28, 29)                   | ⑧ <b>Headphones</b> [🎧] jack (17)   |
| ② <b>Bluetooth PAIRING</b> button (23)                            | ⑨ <b>USB</b> port (26)              |
| ③ <b>INPUT</b> button (17, 23)                                    | ⑩ <b>Display</b>                    |
| ④ <b>Previous</b> [◀◀]/ <b>PRESET</b> [◀] button (19, 22, 25, 29) | ⑪ <b>Disc tray</b> (19)             |
| ⑤ <b>Next</b> [▶▶]/ <b>PRESET</b> [▶] button (19, 22, 25)         | ⑫ <b>Remote control sensor</b> (6)  |
| ⑥ <b>Play/Pause</b> [▶/  ] button (19, 26)                        | ⑬ <b>Open/Close</b> [▲] button (19) |
| ⑦ <b>VOLUME</b> [-]/[+] buttons (17, 22)                          |                                     |

## Getting to Know the CD receiver—Continued

### Display

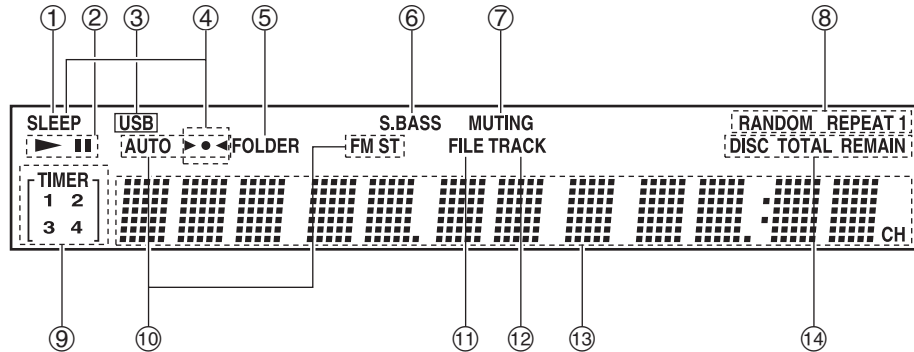

- |                                  |                                      |
|----------------------------------|--------------------------------------|
| ① SLEEP indicator                | ⑨ TIMER indicators                   |
| ② Play ► and Pause ■■ indicators | ⑩ Tuning indicators                  |
| ③ USB indicator                  | ⑪ FILE indicator                     |
| ④ Bluetooth indicators           | ⑫ TRACK indicator                    |
| ⑤ FOLDER indicator               | ⑬ Message area                       |
| ⑥ S.BASS indicator               | ⑭ DISC, TOTAL, and REMAIN indicators |
| ⑦ MUTING indicator               |                                      |
| ⑧ Playback mode indicators       |                                      |

### Rear Panel

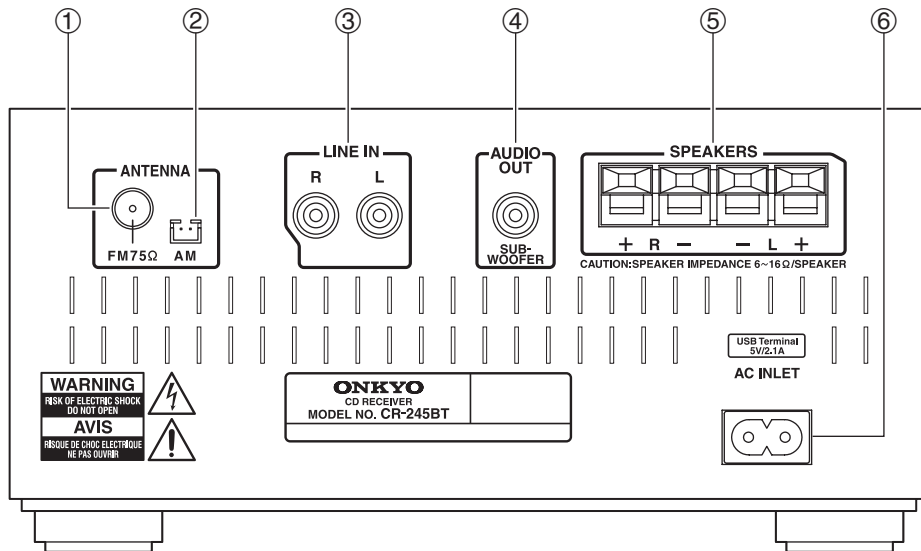

- ① FM ANTENNA jack
- ② AM ANTENNA jack
- ③ LINE IN jack
- ④ AUDIO OUT (SUBWOOFER) jack
- ⑤ SPEAKERS terminals
- ⑥ AC INLET

See pages 13 to 16 for connection information.

## Getting to Know the CD receiver—Continued

### Remote Controller

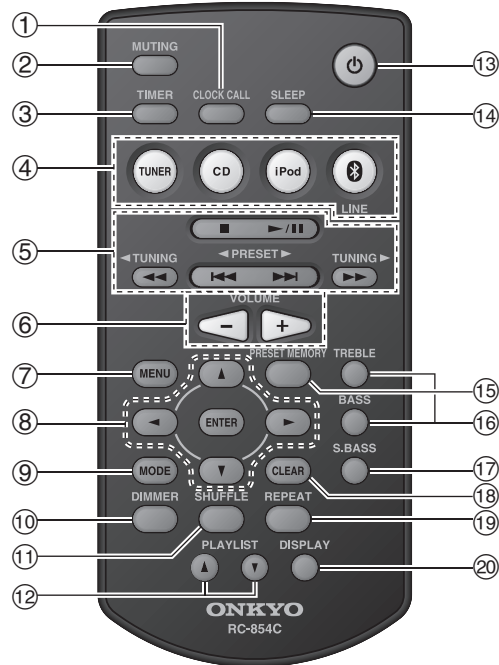

For detailed information, see the pages in parentheses.

- |   |  |
|---|--|
| ① <b>CLOCK CALL</b> button (26)   | ⑩ <b>DIMMER</b> button (18)                  |
| ② <b>MUTING</b> button (17)   | ⑪ <b>SHUFFLE</b> button (21, 22)             |
| ③ <b>TIMER</b> button (26, 27, 28)  | ⑫ <b>PLAYLIST</b> [▲]/[▼] buttons (22)       |
| ④ <b>Input Selector</b> buttons (17, 22, 24, 25, 26)  | ⑬ <b>On/Standby</b> [⏻] button (17, 27, 28)  |
| ⑤ <b>Stop</b> [■] (19, 22),<br><b>Play/Pause</b> [▶/  ] (19, 20, 22, 26),<br>[◀◀]/[▶▶], <b>PRESET</b> [◀]/[▶] (19, 22, 25),<br>[◀◀]/[▶▶], <b>TUNING</b> [◀]/[▶] (19, 22, 24)<br>buttons | ⑭ <b>SLEEP</b> button (28)                   |
| ⑥ <b>VOLUME</b> [-]/[+] buttons (17, 22)  | ⑮ <b>PRESET MEMORY</b> button (24, 25)       |
| ⑦ <b>MENU</b> button (22)   | ⑯ <b>TREBLE/BASS</b> buttons (18)            |
| ⑧ <b>Arrow</b> [▲]/[▼]/[◀]/[▶] buttons and <b>ENTER</b><br>button   | ⑰ <b>S.BASS</b> button (18)                  |
| ⑨ <b>MODE</b> button (20, 24)   | ⑱ <b>CLEAR</b> button (18, 21, 25)           |
|   | ⑲ <b>REPEAT</b> button (21, 22)              |
|   | ⑳ <b>DISPLAY</b> button (19, 20, 23, 26, 27) |

# Disc (Audio CD and MP3) and USB Flash Drive (MP3) Notes

## Precautions for Playback

Compact discs (CDs) with the following logo on the label surface can be used.

Do not use discs designed for purposes other than audio, such as CD-ROMs for PC use. Abnormal noise could damage the CD receiver.



- \* The CD receiver supports CD-R and CD-RW discs. Note that some discs may not playback because of the disc characteristics, scratches, contamination or the recording state. A disc recorded with an audio CD record will not playback unless it is finalized.

Never use discs which have a special shape (such as hearts or octagons). These types of discs could jam and damage the CD receiver.

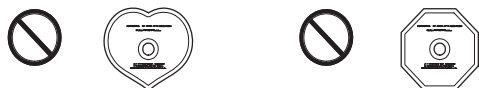

## CD Playback with Copy-control Function

Some audio CDs with copy-control function do not comply with official CD standards. These are special discs and cannot be played with the CD receiver.

## Playback of MP3 Discs

MP3 files recorded on a CD-R/CD-RW can be played with the CD receiver.

- Use discs which have been recorded following the ISO 9660 Level 2 file system. (The supported directory depth is eight levels, the same as ISO 9660 Level 1)
- Discs recorded with the hierarchical file system (HFS) cannot be played.
- Discs must be closed (finalized).
- Only MP3 files with the extension “.MP3” or “.mp3” are supported.
- Files recorded using MPEG 1 audio layer 3 at sampling frequencies of 32/44.1/48 kHz and a constant bit rate (CBR) of 32–320 kbps are supported.
- A maximum of 299 folders can be recognized on a single CD. A maximum of 648 files can be recognized in a single folder.

## Playback from USB Flash Drives

MP3 files recorded on a USB flash drive can be played with the CD receiver.

- USB flash drives formatted in FAT16 or FAT32 are supported.
- Only MP3 files with the extension “.MP3” or “.mp3” are supported.
- Files recorded using MPEG 1 audio layer 3 at sampling frequencies of 32/44.1/48 kHz and a constant bit rate (CBR) of 32–320 kbps are supported.
- A maximum of 299 folders can be recognized on a single USB flash drive. A maximum of 648 files can be recognized in a single folder.

### Note:

- A disc recorded with a recorder or personal computer may not play in some cases. (Cause: Disc's characteristics, damaged or dirty disc, dirt on player's lens, dew condensation, etc.)
- A disc recorded on a personal computer may not play because of the application settings or environment. Record the disc with the proper format. (Contact the application maker for details.)
- A disc with insufficient storage capacity may not playback properly.

## Handling Discs

Hold discs by the edge, or by the center hole and edge. Avoid touching the playback surface (surface with nothing printed on it).

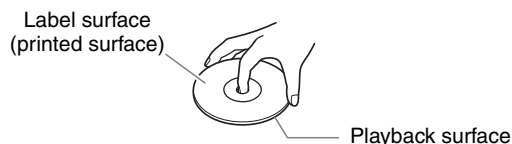

Do not attach paper or stickers, or write on the playback or label surface of the disc. Take care not to scratch or damage the disc.

## Precautions for Rental Discs

Do not use discs with residue from cellophane tape, rental discs with labels which are peeling off, or discs with decorative labels. This type of disc could get stuck in the CD receiver, or could damage the CD receiver.

## Disc (Audio CD and MP3) and USB Flash Drive (MP3) Notes—Continued

### Precautions for Inkjet Printable Discs

Do not leave a CD-R/CR-RW having a label printed with an inkjet printer in the CD receiver for a long time. The disc could get stuck in the CD receiver, or could damage the CD receiver.

Remove the disc from the CD receiver when not being played, and store it in a case. A freshly printed disc will stick easily, and should not be played immediately.

### Caring for Discs

If the disc is dirty, the CD receiver will have a hard time reading signals, and the audio quality may drop. If the disc is dirty, gently wipe off fingerprints and dust with a soft cloth. Lightly wipe from the center outwards.

To remove stubborn dust or dirt, wipe the disc with a soft cloth dampened with water, and then dry it with a dry cloth. Do not use cleaning spray for analog records or antistatic agents, etc. Never use volatile chemicals such as benzine or paint thinner as they can impregnate the disc surface.

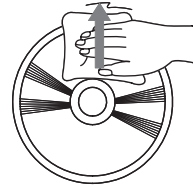

## Connecting Speakers

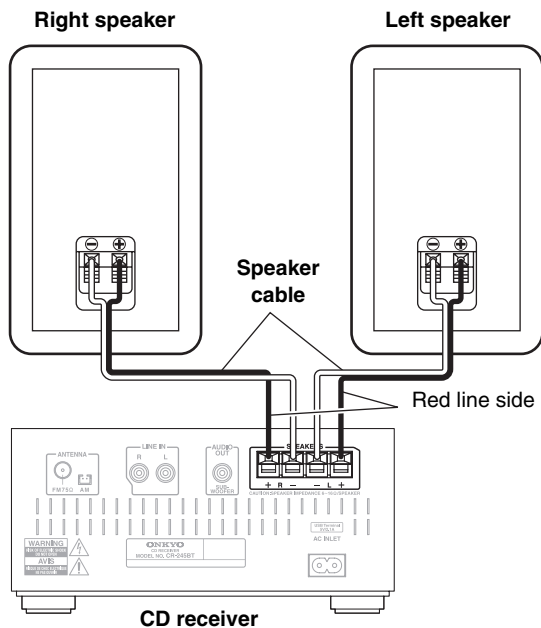

- Pay close attention to speaker wiring polarity. Connect positive (+) terminals to only positive (+) terminals, and negative (–) terminals to only negative (–) terminals. If you get them the wrong way around, the sound will be out of phase and will sound unnatural.
- Use the red line wires to connect the positive (+) terminals.
- Do not connect anything other than the included speakers (D-T05). We cannot take responsibility for malfunctions or poor results if this CD receiver is used with any other speakers.
- Do not connect both speaker cables to the same L or R terminals. Do not connect more than two speaker terminals to each speaker.

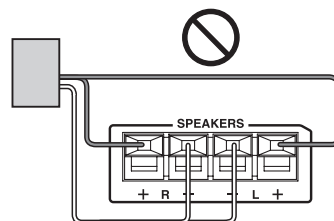
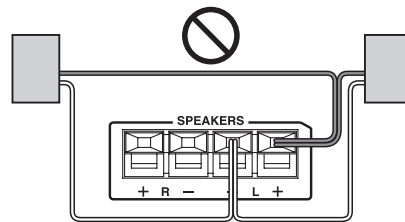

Remove the precut insulation from the ends of the speaker cables, and twist the bare wires tightly.

Push the lever to open the hole, insert the bare wire into the hole, and then release the lever.

Make sure that the speaker terminals are gripping the bare wires, not the insulation.

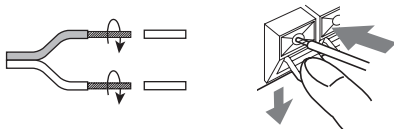

- Connect the right speaker to the CD receiver's right (R) SPEAKERS terminals. Connect the left speaker to the left (L) SPEAKERS terminals.

- Be careful not to short the positive and negative wires. Doing so may damage the CD receiver and/or speakers.



# Connecting the Antennas

This section explains how to connect the supplied indoor FM antenna and AM loop antenna. The CD receiver won't pick up any radio signals if no antenna is connected, so you must connect the antenna to use the tuner.

## Connecting the Indoor FM Antenna

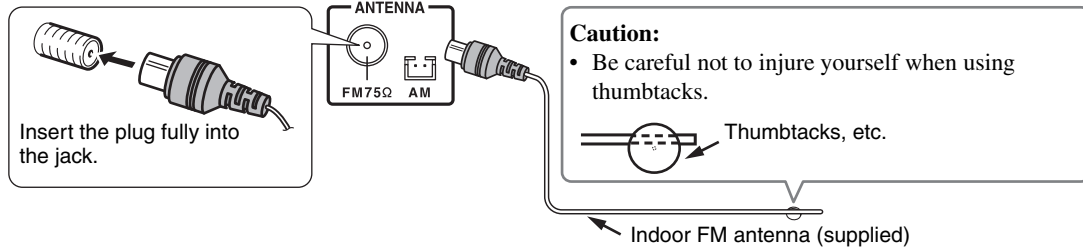

### Note:

- Once your CD receiver is ready for use, you'll need to tune into a radio station and position the antenna to achieve the best possible reception.

### Tip:

- If you cannot achieve good reception with the supplied indoor FM antenna, try a commercially available outdoor FM antenna instead.

## Connecting the AM Loop Antenna

The supplied indoor AM loop antenna is for indoor use only.

### 1 Assemble the AM loop antenna, inserting the tabs into the base, as shown.

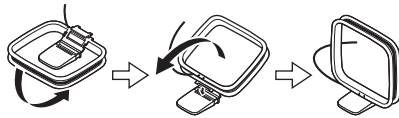

### 2 Plug the AM loop antenna into the AM antenna jack, as shown.

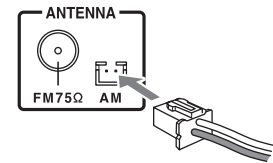

### ■ Adjusting the AM Loop Antenna

Adjust the location and position of the AM antenna while listening to an AM station to achieve the best possible reception.

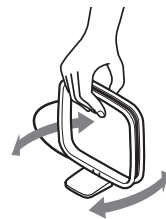

## Connecting an Outdoor FM Antenna

If you cannot achieve good reception with the supplied indoor FM antenna, try a commercially available outdoor FM antenna instead.

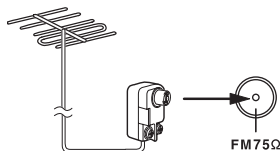

### Note:

- Outdoor FM antennas work best outside, but usable results can sometimes be obtained when installed in an attic or loft.
- For best results, install the outdoor FM antenna well away from tall buildings, preferably with a clear line of sight to your local FM transmitter.
- Outdoor antenna should be located away from possible noise sources, such as neon signs, busy roads, etc.
- For safety reasons, outdoor antenna should be situated well away from power lines and other high-voltage equipment.
- Outdoor antenna must be grounded in accordance with local regulations to prevent electrical shock hazards.

## Connecting the Antennas—Continued

### ■ Using a TV / FM Antenna Splitter

It's best not to use the same antenna for both FM and TV reception, as this can cause interference problems.

If circumstances demand it, use a TV / FM antenna splitter, as shown.

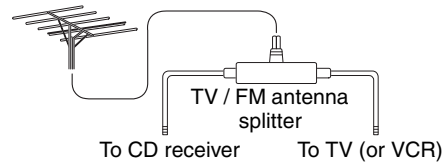

## Connecting Other Components

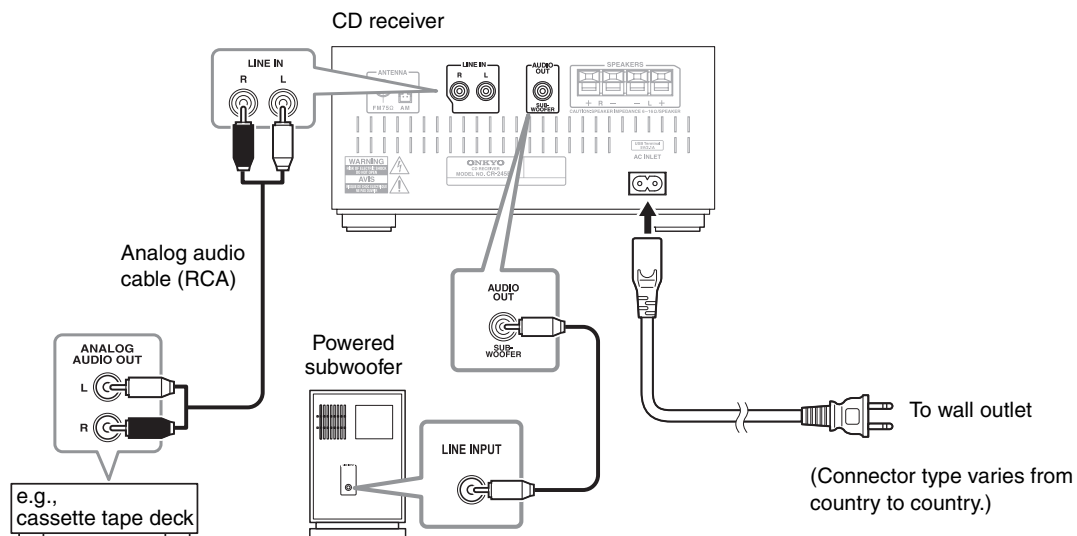

### About Connections

- Before making any connections, read the manuals supplied with your other components.
- Don't connect the power cord until you've completed and double-checked all connections.

Push plugs in all the way to make good connections (loose connections can cause noise or malfunctions).

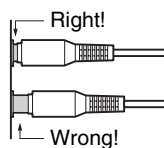

#### Note:

- Do not put anything on top of the CD receiver, as it may interfere with proper ventilation.

### Connecting a Powered Subwoofer

Using a suitable cable, connect the CD receiver's AUDIO OUT: SUBWOOFER to the input on your powered subwoofer.

If your subwoofer is unpowered and you're using an external amplifier, connect the AUDIO OUT: SUBWOOFER to the amp's input.

#### Note:

- Do not connect or disconnect the power cord while the subwoofer is powered-on. Doing so may damage the subwoofer. You must power-off the subwoofer before connecting or disconnecting the power cord.

### Connecting an Audio Playback Device

Using a suitable cable, connect the CD receiver's LINE IN jacks to the OUTPUT (PLAY) jacks of your cassette tape deck, TV, or other audio playback device.

## Connecting Other Components—Continued

### Connecting the Power Cord

Connect the CD receiver's power cord to a suitable wall outlet.

**Note:**

- Do not use any cord other than the included power cord.  
Do not connect the included power cord to any other device. Doing so may cause malfunctions or accidents.
- Do not unplug the power cord from the AC INLET while the other end of the cord is still connected to an AC outlet. You may receive an electric shock if you accidentally touch the internal terminals of the power cord.
- Before connecting the power cord, connect all of your speakers and AV components.
- Turning on the CD receiver may cause a momentary power surge that might interfere with other electrical equipment on the same circuit. If this is a problem, plug the receiver into a different branch circuit.
- Plug the power cord into an AC outlet that is easily accessible so that you can quickly unplug it if necessary.



# Basic Operations

This section describes the procedure for using the remote controller, unless otherwise specified.

## Turning On the CD receiver

**Press the On/Standby [ $\odot$ ] button.**

The CD receiver comes on, and the display lights up. Press the On/Standby [ $\odot$ ] button again to set the CD receiver to Standby.

You can also use the [ $\odot$  ON/STANDBY] button on the CD receiver.

During the use of your iPod/iPhone/iPad connected to the CD receiver with a USB cable, if the connection mode of the CD receiver is set to iPod (see page 22), “Charging” appears on the display of the CD receiver and your iPod/iPhone/iPad will be charged even with the CD receiver on standby.

### Tip:

- For details on power management settings, see “Setting Auto Standby (ASb)”.

## Setting Auto Standby (ASb)

With Auto Standby, you can set the CD receiver so that it will be automatically turned off and enter the standby mode if there is no operation for 20 minutes with no audio input.

The default setting is “Off”.

Make settings for this function while playback is stopped.

### 1 Press and hold down the remote controller's [SLEEP] button (about 3 seconds).

If this setting is “On”, “AutoStby On” will appear on the CD receiver's display.

### Note:

- To switch between “On” and “Off”, repeat this procedure.
- If an iPod/iPhone/iPad is connected, ASb will not operate because the connected unit is being charged.
- If playback is paused, the power will remain on even after 20 minutes have elapsed; the Auto Standby function will not operate.
- With Bluetooth Standby “On”, the CD receiver will enter the Bluetooth Standby mode if the Auto Standby function is enabled (see page 23).

## Selecting the Input Source

You can select CD, iPod (USB), FM, AM, Bluetooth, or LINE, which can be an external component.

To select the input source, use the remote controller's Input Selector buttons. On the CD receiver, press the [INPUT] button repeatedly.

The input sources are selected in the following order.

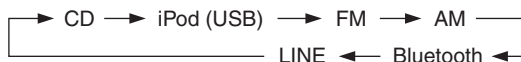

## Adjusting the Volume

**To adjust the volume, use the VOLUME [-]/[+] buttons.**

You can also use the CD receiver's VOLUME [-]/[+] buttons.

## Muting the CD receiver

You can temporarily mute the output of the CD receiver.

**Press the [MUTING] button.**

The CD receiver is muted.

“Muting” appears on the display for a few seconds. The MUTING indicator flashes continuously while the CD receiver is muted.

### Note:

- To unmute, press the [MUTING] button again or adjust the volume.
- Muting is automatically cancelled when the CD receiver is set to standby.

## Using Headphones

You can connect a pair of stereo headphones (ø3.5 mm, 1/8-inch phone plug) to the receiver's headphones [🔌] jack for private listening.

### Note:

- Always turn down the volume before connecting your headphones.
- While the headphones plug is inserted in the headphones [🔌] jack, the speakers are turned off.

## Basic Operations—Continued

---

### Adjusting the Bass and Treble

Press the [BASS] or [TREBLE] button, and then use the [▲]/[▼] buttons to adjust the bass or treble, respectively.

The default setting is “0”. You can adjust the bass and treble from -5 to +5.

While adjusting the bass or treble, you can press the [CLEAR] button to return the setting to “0”.

**Note:**

- If you press no buttons for about 5 seconds, the previous display will appear automatically.

### Using Super Bass

To turn on Super Bass, press the [S.BASS] button.

The setting will alternate between S.Bass Off, S.Bass 1, and S.Bass 2 each time you press the button.

To turn off Super Bass, press the [S.BASS] button repeatedly until “S.Bass Off” appears.

The default setting is “Off”.

### Changing the Display Brightness

You can adjust the brightness of the display.

Press the [DIMMER] button repeatedly to select: dim, or normal brightness.

# Playing CDs

This section describes the procedure for using the remote controller, unless otherwise specified.

## Playing CDs

### 1 Press the CD receiver's [▲] button to open the disc tray.

**Tip:**

- Pressing the [▲] button while the CD receiver is on Standby will turn on the CD receiver and open the disc tray.

### 2 Place CD on the tray with the label-side facing up.

Place 8 cm CDs in the center of the tray.

### 3 To start playback, press the CD receiver's [▶/||] button.

Alternatively, press the remote controller's [CD] button followed by the [▶/||] button. The disc tray closes and playback starts. Then the "▶" indicator appears.

#### To stop playback:

Press the [■] button.

Playback stops automatically when the last track has been played.

#### To pause playback:

Press the [▶/||] button. The Pause "||" indicator appears. To resume playback, press the [▶/||] button again.

#### To Fast-Forward or Fast-Reverse:

During playback, press and hold the Fast Forward [▶▶] button to fast forward, or the Fast Reverse [◀◀] button to fast reverse.

#### To remove the CD:

Press the CD receiver's [▲] button to open the disc tray.

#### ■ Information Displayed When Playback is Stopped:

- Audio CD

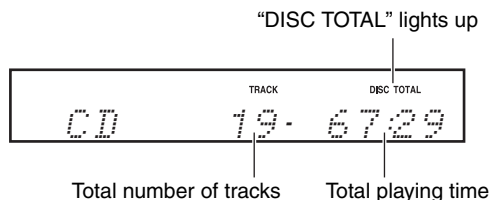

## Selecting Tracks

To return to the beginning of the track currently playing, press the Previous [◀◀] button.

Press the Previous [◀◀] button repeatedly to select earlier tracks.

Press the Next [▶▶] button repeatedly to select subsequent tracks.

## Displaying CD Information

During playback or while playback is paused, press the [DISPLAY] button repeatedly to display the following CD information.

- **Elapsed time**
- **"REMAIN"**
- Lights up while the remaining track time is being displayed.
- **"TOTAL REMAIN"**
- Lights up while the remaining disc time is being displayed.
- **Type of CD**

## Playing CDs—Continued

### Selecting MP3 Files

The files on an MP3 CD can be located at the disc's root level or within a folder.

A folder can contain additional folders, with other folders inside them in a hierarchical structure.

A maximum of 648 files and folders (total) can be shown within a folder. Files and folders are listed alphabetically without distinction.

If you don't select a specific MP3 file or folder for playback, all of the MP3 files will be played in numerical order starting with file #1.

If random playback is selected, the files will not be played in the numerical order. If you want the files to play in the numerical order, you must cancel random playback (see page 21).

#### 1 While playback is stopped, press the [MODE] button.

"FOLDER" will light, and the name of the first folder will be shown.

#### 2 Use the arrow [▲]/[▼] buttons to select a folder.

Press the [ENTER] button or the [▶] button to enter the folder.

Repeat this operation to select the desired folder.

When the " # #" message is shown, you can press the [ENTER] button to return to the upper-level folder.

#### 3 Use the arrow [▲]/[▼] buttons to select the MP3 files within the folder.

The name of the MP3 file inside the folder is displayed.

To select a different folder, press the [◀]/[▶] button, then use the [▲]/[▼] buttons to select the desired folder, and finally press the [ENTER] button. Use the [▲]/[▼] buttons to select the desired file.

#### 4 To start playback, press the [ENTER] button or Play/Pause [▶/||] button.

Playback will start with the specified file and continue until all of the MP3 files have been played.

To select an MP3 file in another folder during playback, press the [MODE] button, select the folder by using the arrow [◀]/[▶]/[▲]/[▼] buttons, and then press the [ENTER] button. Now use the arrow [▲]/[▼] buttons to select the MP3 files within that folder.

#### ■ Pausing Playback

To pause playback, press the Play/Pause [▶/||] button.

To resume playback, press it again.

#### ■ Selecting a higher or lower folder

Press the [◀] button to select a higher-level folder, or the [▶] button to select a lower-level folder.

#### ■ To return to the root

Press the [MODE] button, and then press the [MENU] button.

### Displaying MP3 Information

You can display various information about the MP3 file currently playing, such as title, artist, and album.

#### During playback, press the [DISPLAY] button repeatedly to display the following MP3 information.

The information is shown in the following order.

**Elapsed time:** The length of time that the current MP3 file has been playing (default display).

**Remain time:** The length of remaining time for the current MP3 file.

**File name:** Name of the current MP3 file.

**Folder name:** Name of the current folder.

**Sampling rate and bit rate:** Sampling rate and bit rate of the current MP3 file.

**Volume label:** Title of the current disc.

#### Note:

- Only single-byte alphanumeric characters can be shown.
- A folder name, file name, or volume label that contains anything other than single-byte alphanumeric characters might be garbled.

## Playing CDs—Continued

### Random Playback

With random playback, all of the tracks on the disc are played in random order.

Random playback can also be used in conjunction with repeat playback.

**Note:**

- In the case of MP3 files, the same song might be played.

Random playback can be set when the input source is set to CD or USB.

**1 Press the [SHUFFLE] button until the RANDOM indicator appears.**

**2 To start random playback, press the Play/Pause [▶/||] button.**

#### ■ Cancelling Random Playback

To cancel random playback, press the [SHUFFLE] or [CLEAR] button.

When playing a CD, random playback will be cancelled automatically when the CD is removed.

### Repeat Playback

With repeat playback, you can play an entire CD repeatedly or play one track repeatedly.

Repeat playback can also be used in conjunction with random playback.

**Press the [REPEAT] button repeatedly until the REPEAT or REPEAT 1 indicator appears.**

“REPEAT” will repeatedly play all songs.

“REPEAT 1” will repeatedly play the currently-playing song or the selected song.

**Note:**

- If REPEAT 1 is selected, pressing the [SHUFFLE] button will cancel REPEAT 1; random playback will occur.

#### ■ Cancelling Repeat Playback

To cancel repeat playback, press the [REPEAT] button repeatedly until both the REPEAT and REPEAT 1 indicators disappear.

When playing a CD, repeat playback will be cancelled automatically when the CD is removed.

# Playing Your iPod/iPhone/iPad

This section describes the procedure for using the remote controller, unless otherwise specified.

- Before using your iPod/iPhone/iPad with the CD receiver, be sure to update your iPod/iPhone/iPad with the latest software, available from the Apple Web site.
- Depending on your iPod/iPhone/iPad, or the type of content being played, some functions may not work as expected.

## Playing an iPod/iPhone/iPad via USB

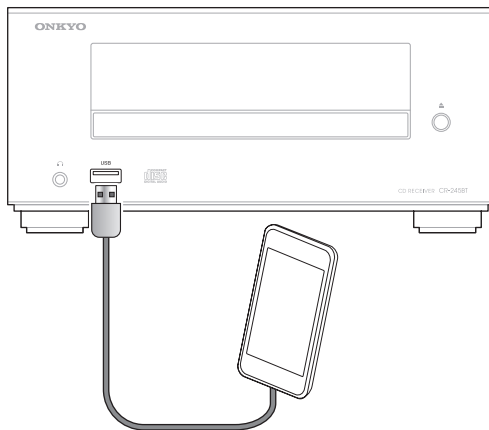

Compatible iPod/iPhone/iPad models

Made for:

iPod touch (1st, 2nd, 3rd and 4th generation), iPod nano (2nd, 3rd, 4th, 5th and 6th generation), iPhone, iPhone 3G, iPhone 3GS, iPhone 4, iPhone 4S, iPad, iPad 2 and iPad (3rd generation)

### 1 Press the [iPod] button.

Alternatively, you can use the CD receiver's [INPUT] button.

**Note:**

- If "USB" appears on the display of the CD receiver, the connection mode is set to USB. Press and hold the [MODE] button until "iPod" appears to switch the connection mode to iPod. And then reconnect your iPod/iPhone/iPad with a USB cable.

### 2 Connect the USB cable that comes with the iPod/iPhone/iPad to the USB port on the front of the CD receiver.

While reading the contents of your iPod/iPhone/iPad, the message "Connecting" appears on the CD receiver's display.

"iPod" appears on the display of the CD receiver. If your iPod/iPhone/iPad is not connected properly, "No Device" appears.

**Tip:**

- When connecting your iPod/iPhone/iPad with a USB cable, we recommend you use an official USB cable from Apple Inc.

### 3 Press the Play/Pause [▶/||] button. Playback starts.

#### ■ Pausing Playback

To pause playback, press the Play/Pause [▶/||] button. Press the Play/Pause [▶/||] button again to resume playback. You can also pause playback by pressing the [■] button.

#### ■ Selecting Tracks

To return to the beginning of the track that's currently playing or paused, press the Previous [◀◀] button.

Press the Previous [◀◀] button repeatedly to select earlier tracks.

Press the Next [▶▶] button repeatedly to select subsequent tracks.

#### ■ Fast-Forward or Fast-Rewind

During playback, press and hold the Fast Forward [▶▶▶] button to fast forward, or the Fast Reverse [◀◀◀] button to fast reverse.

#### ■ Random Playback

Press the [SHUFFLE] button repeatedly to switch the random function of your iPod/iPhone/iPad.

#### ■ Repeat Playback

Press the [REPEAT] button repeatedly to switch the repeat function of your iPod/iPhone/iPad.

#### ■ Selecting Playlist

Press the PLAYLIST [▲]/[▼] button to select the playlist.

## Navigating the iPod Menus with the Remote Controller

### 1 Press the [MENU] button to display the iPod menu.

### 2 Use the Arrow [▲]/[▼]/[◀]/[▶] buttons to select an item on the menu, and then press the [ENTER] button.

**Note:**

- The volume level is adjusted by using the VOLUME [-]/[+] buttons on the CD receiver or its remote controller. Adjusting the volume on your iPod/iPhone/iPad has no effect.

# Playing Back via Bluetooth

## Listening to an audio from Bluetooth device

### Note:

- If your mobile phone supports A2DP protocol, its music will play through the CD receiver.
- You can build a Bluetooth connection with a mobile phone, an iPod or any other Bluetooth-enabled devices.

### 1 Press the [INPUT] button on the top panel repeatedly to select the “Bluetooth” input.

#### Tip:

- Alternatively, you can use the remote controller’s [Ⓜ/LINE] button.

### 2 Press the [Ⓜ Bluetooth PAIRING] button on the top panel, to put the CD receiver into the pairing mode.

“Pairing...” appears on the CD receiver’s display.

If you hold the [Ⓜ Bluetooth PAIRING] button for more than 2 seconds during the process of pairing, the operation will be cancelled.

### 3 During this period, you can operate the mobile phone, iPod or Bluetooth-enabled device to pair with the CD receiver within a 10m range.

For details on the Bluetooth connection, refer to the user manual of the Bluetooth-enabled device.

The CD receiver may not work as normal depending on the circumstance even though the CD receiver is placed within the 10 m range. In such cases, get the Bluetooth-enabled device closer to the CD receiver and retry the operation.

### 4 Once the CD receiver is detected and its name “Onkyo CR-245BT” appears on the display of your Bluetooth-enabled device, select the “Onkyo CR-245BT.” If a prompt requests a password, key in the “0000”.

When a Bluetooth connection is established successfully, the “▶●◀” indicator will be solid on and “Bluetooth” appears on the display of the CD receiver.

### 5 Select the desired music and press “▶/||” button on your device. The CD receiver automatically starts playing the audio.

If the “▶●◀” indicator is not lit and “Bluetooth” appears on the display of the CD receiver after 2 minutes have elapsed after “Pairing...” appears, this means that the pairing is not done successfully. Perform the above procedure 1 to 4 again.

### Note:

- If there is no sound output even after the pairing is done successfully, consult the user manual of the Bluetooth-enabled device, and then select the “Onkyo CR-245BT” as the audio output device.
- The CD receiver can store the pairing information of up to 8 Bluetooth devices. If the pairing is done for the ninth Bluetooth device, the pairing information of device connected via Bluetooth in the most past times is erased.
- The multiple Bluetooth devices cannot be connected at the same time.

## Displaying Bluetooth Information

If you press the [DISPLAY] button during the Bluetooth connection, the following Bluetooth information appears.

The information is shown in the following order.

- **Audio CODEC**
- **Sampling frequency**

## Setting Bluetooth Standby

With Bluetooth Standby, you can set the CD receiver so that it will be automatically turned on if the Bluetooth device is operated while the CD receiver is on standby.

The default setting is “Off”.

Make settings for this function while CD receiver is in standby mode.

### Press and hold the [Ⓜ ON/STANDBY] button on the CD receiver while it is on standby (about 3 seconds).

The SLEEP indicator will be dimly-lit.

### Note:

- To switch between “On” and “Off”, repeat this procedure.

# Listening to the Radio

This section describes the procedure for using the remote controller, unless otherwise specified.

## Tuning into FM Radio Stations

When tuned to a station, the Tuned (▶●◀) indicator appears. When receiving a stereo FM signal, the FM ST indicator appears as well.

The [MODE] button is used to select Auto mode or Mono mode. In Auto mode, the output will be stereo or mono depending on the station being received. In Mono mode, the output will be mono regardless of the station.

### 1 Press the [TUNER] button repeatedly to select “AM” or “FM”.

Alternatively, you can use the CD receiver’s [INPUT] button.

### 2 Use the TUNING [◀]/[▶] buttons to tune into a station.

Each time you press the TUNING button, the frequency changes 0.2 MHz steps for FM and 10 kHz steps for AM.

If you press and hold a TUNING button, the frequency will change continuously. Once you release the button, tuning will stop automatically when a frequency on which a radio station is broadcasting is found. If you want to interrupt this process, press the [CLEAR] button.

### Tuning into weak stereo FM stations

If the signal from a stereo FM station is weak, it may be impossible to get good reception. In this case, press the [MODE] button to switch to Mono mode and listen to the station in mono.

## Presetting FM Stations Automatically (Auto Preset)

With the Auto Preset function, you can automatically preset all of the FM radio stations available in your area in one go. Presets make it easy to select your favorite stations and eliminate the need to tune the radio manually each time you want to change stations.

As an alternative to this Auto Preset function, there’s also a Manual Preset function that lets you manually preset individual FM stations (see page 25).

### Auto Preset Caution!

Any existing presets will be deleted when the Auto Preset function is run.

### 1 Press the [TUNER] button repeatedly to select “FM”.

Alternatively, you can use the CD receiver’s [INPUT] button.

Make sure the FM antenna is positioned to achieve the best possible reception.

### 2 Press the [PRESET MEMORY] button. “Auto Preset?” appears on the display.

### 3 To start the Auto Preset function, press [ENTER].

Up to 30 stations can be preset and presets are stored in frequency order.

If you want to interrupt the Auto Preset process, press the [CLEAR] button.

### Note:

- Depending on your location, a preset may be stored with no station, and you’ll hear only noise when you select it. In this case, delete the preset (see page 25).



## Listening to the Radio—Continued

### Presetting AM/FM Stations Manually

With the Preset Write function, you can manually preset individual AM and FM radio stations. Presets make it easy to select your favorite stations and eliminate the need to tune the radio manually each time you want to change stations.

FM stations can also be preset automatically (see page 24).

### About Presets

You can store up to 30 AM and 30 FM stations as presets.

**1 Tune into the station that you want to store as a preset (see page 24).**

**2 Press and hold down the [PRESET MEMORY] button to the preset number flashes.**

When the preset has been stored, the preset number will change from blinking to steadily lit.

Preset numbers are automatically stored starting with the lowest unused number.

If all 30 AM or 30 FM presets have been set, the display will indicate “Preset FULL,” and no further presets can be stored. You’ll need to erase an existing preset before storing another one.

### Selecting Preset Stations

You must store some presets before you can select them (see pages 24 to 25).

**1 Press the [TUNER] button repeatedly to select “AM” or “FM”.**

Alternatively, you can use the CD receiver’s [INPUT] button.

The preset you selected the last time you listened to the radio will be selected.

**2 Use the PRESET [◀]/[▶] buttons to select a preset.**

Press the PRESET [◀] button to select the previous preset. Press the PRESET [▶] button to select the next preset.

### Tip:

- If you press the remote controller’s [TUNER] button while the CD receiver is on Standby, it will turn on automatically and the station that you listened to last time will be heard.

### Erasing Presets

**1 Select the preset you want to erase.**

**2 Press and hold down the [CLEAR] button to erase the preset.**

When the preset has been erased, presets following the erased preset will be renumbered forward and redisplayed.

## Playing a USB Flash Drive

This section describes the procedure for using the remote controller, unless otherwise specified.

- 1 Press the [iPod] button to select “iPod”.**  
Alternatively, you can use the CD receiver’s [INPUT] button.
- 2 Press and hold the [MODE] button until “USB” appears (about 3 seconds).**
- 3 Insert a USB flash drive in the USB port.**

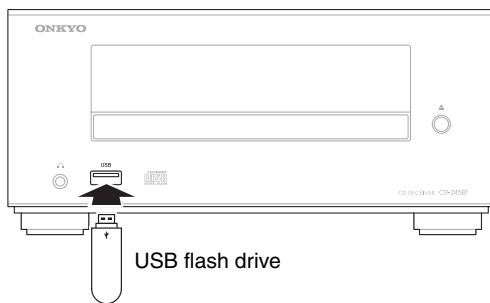

- 4 To start playback, press the [▶/||] button.**  
Selecting folders and files, and using the random play and repeat play functions, are the same as when playing back MP3 files from a CD (see page 20).

### Note:

- Do not connect your USB flash drive via a USB hub.
- When connecting or disconnecting a USB flash drive, use your hand to support the CD receiver so that it does not move.
- For details on the usable formats for a USB flash drive, refer to page 12 “Playback from USB Flash Drives”.
- If your iPod/iPhone/iPad is used, switch the connection mode to iPod (see page 22).
- Do not connect the CD receiver’s USB port to a USB port on your computer. Music on your computer cannot be played through the CD receiver in this way.

## Setting the Clock

This section describes the procedure for using the remote controller, unless otherwise specified.

### Setting the Clock

- 1 Press the [TIMER] button repeatedly until “Clock” appears.**
- 2 Press [ENTER].**
- 3 Use the arrow [▲]/[▼] buttons to enter the current hour.**  
When the CD receiver is shipped from the factory, the time display format is set to 24-hour time. Set the current hour as it would appear in 24-hour time. If you want to set the current hour as 12-hour time, press the [DISPLAY] button.
- 4 Press [ENTER].**
- 5 Use the arrow [▲]/[▼] buttons to enter the current minute.**
- 6 Press [ENTER].**  
The clock is set and the second dot starts flashing.

### Displaying the Time

To display the time, press the remote controller’s [CLOCK CALL] button. Press the button again or perform another operation to cancel the time display. If the CD receiver is on Standby, the time will be displayed for about 8 seconds.

While the CD receiver is on, the time are displayed continuously.

### Change the time format

To change the time format between 12-hour and 24-hour, press the [DISPLAY] button.

## Using the Timer

This section describes the procedure for using the remote controller, unless otherwise specified.

The CD receiver has a programmable timer for automated playback, and a sleep timer for turning the CD receiver off after a specified period.

You can also use the alarm playback function of your iPod to initiate timer playback on the CD receiver.

The timer can be used to start AM/FM, CD, iPod/USB, or LINE playback at a specified time. You could, for example, use a timer to turn on the CD receiver every morning, just like a radio alarm clock.

### Note:

- If iPod is selected as the input source for the timer settings, USB will play if only a USB flash drive is connected, and iPod/iPhone/iPad will play if an iPod/iPhone/iPad is connected.

### Programming the Timer

#### Note:

- You must set the clock before you can program the timer.
- If you don't operate any buttons for about 5 seconds while programming a timer, the procedure will be cancelled and the previous display will reappear.
- When the CD receiver is turned on by the timer, playback will begin with the most recently received station in the case of AM/FM, the first song in the case of a CD or iPod (USB), and the current state of the connected device in the case of LINE.
- Only one timer can be set.

### 1 Prepare the source that you want the timer to play.

If you want AM/FM to play, tune to the station you want to hear.

If you want a CD to play, insert the disc.

If your iPod/iPhone/iPad is used, switch the connection mode to iPod (see page 22). If your USB flash drive is used, switch the connection mode to USB (see page 26).

If you want to play a device connected to LINE, make settings on the connected device so that it will start playing when the timer operates.

### 2 Press the [TIMER] button repeatedly until "Timer XX" appears.

"XX" indicates the source that was last selected for timer playback.

### 3 Use the arrow [▲]/[▼] buttons to select the source, and then press [ENTER].

You can select the following sources:

AM/FM, CD, iPod (USB), LINE.

In the display, "TIMER" and a number indication will blink according to the input source you've selected.

The number will be "1" for AM/FM, "2" for CD, "3" for iPod (USB), and "4" for LINE.

### 4 Use the arrow [▲]/[▼] buttons to specify the "hour" at which you want the timer to play, and then press [ENTER].

### 5 Use the arrow [▲]/[▼] buttons to specify the "minute" at which you want the timer to play, and then press [ENTER].

### 6 Use the arrow [▲]/[▼] buttons to select "Timer On," and then press the [ENTER] button.

When a timer is turned on, its TIMER and number appears on the display.

If there is no operation for several seconds, the setting will be made with the currently-shown content.

The display will return to its previous state except for "TIMER" and the number of the selected input source; the timer is now set.

### 7 Press the On/Standby [⏻] button to set the CD receiver to Standby.

#### Tip:

- If you decide to cancel during this procedure without making timer settings, press the [TIMER] button.
- By pressing the [DISPLAY] button when specifying the time, you can switch between 12-hour and 24-hour displays.

#### Note:

- Be sure to set the CD receiver to Standby, otherwise the timed operation will not work. If the timer has been set, timed operation will work even if the SLEEP timer caused the CD receiver to enter Standby mode. Once the timer has been turned on, playback will start at the same time every day. Be sure to turn off the timer before leaving on vacation.
- If the timer turns the power on, the "SLEEP" indication will light. If no operation is performed for one hour, the CD receiver will automatically enter Standby mode. If you perform any operation, the "SLEEP" indication will turn off, and the CD receiver will continue operating.

## Using the Timer—Continued

### Turning Timer On and Off

Once a timer has been programmed, you can turn it on or off as necessary. For example, while you're on holiday, you may want to turn off the timer you use as an early morning alarm.

**1 Press the [TIMER] button repeatedly until “Timer On” or “Timer Off” appears.**

**2 Use the arrow [▲]/[▼] buttons to select either “Timer On” (set) or “Timer Off” (cancel), and then press the [ENTER] button.**

If there is no operation for several seconds, the setting will be made with the currently-shown content, and the display will return to its previous state.

If you specify Timer On (set), the “TIMER” indication and the number of the selected input source will light.

If you select Timer Off (i.e., turn off the timer), the “TIMER” indicator will disappear.

### Using the Sleep Timer

With the sleep timer, you can set the CD receiver so that it automatically turns off after a specified period.

**Press the [SLEEP] button repeatedly to select the required sleep time.**

With the [SLEEP] button, you can set the sleep time from 90 to 10 minutes in 10 minute steps.

When the sleep timer has been set, the SLEEP indicator appears on the display. The sleep time appears on the display for about 3 seconds, then the previous display reappears.

### Checking the Remaining Sleep Time

To check the remaining sleep time, press the [SLEEP] button.

Note that if you press the [SLEEP] button while the sleep time is being displayed, you'll shorten the sleep time by 10 minutes.

For example if you press the [SLEEP] button and the remaining time is shown as 55 minutes, pressing the [SLEEP] button once again will shorten this time to 50, and each subsequent press will shorten the time in 10 minute increments.

### Canceling the Sleep Timer

To cancel the sleep timer, press the [SLEEP] button repeatedly until “Sleep Off” appears.

#### Note:

- If the timer turns the power on, the “SLEEP” indication will light. If you perform any operation, the “SLEEP” indication will turn off. If you want to set the SLEEP timer, you'll need to make the setting again after the “SLEEP” indication turns off.

### Timer Playback using the Alarm Play Function of your iPod

When the alarm play function of the iPod connected to the CD receiver starts playing a song, the CD receiver will power-on and switch to the iPod input.

**1 On your iPod, make settings for its alarm play function.**

**2 Repeatedly press the [TIMER] button to make the iPod alarm mode “iPodAlarmOff” message appear.**

**3 Use the arrow [▲]/[▼] buttons to select “iPodAlarmOn”, and then press the [ENTER] button.**

If there is no operation for several seconds, the setting will be made with the currently-shown content, and the display will return to its previous state.

**4 Press the On/Standby [⏻] button to put the CD receiver in standby mode.**

When the alarm play function of the iPod begins, the CD receiver will power-on and the input will be switched to iPod.

#### Note:

- In order for the timer to work, the CD receiver must be in standby mode.
- This function will not work if the iPod is not connected.
- This function won't work when the sound set for the alarm is a built-in sound (Beep).
- This function won't work with models on which music files cannot be used to set the alarm sound.

#### Tip:

- This function will power-on the CD receiver and switch the input to iPod when it detects a song being played back by the iPod. If you play back a song on the iPod without using its alarm play function, the CD receiver will power-on and switch to the iPod input in the same way.

# Troubleshooting

If you have any trouble using the CD receiver, look for a solution in this section.

If you can't resolve the issue yourself, try resetting the CD receiver before contacting your Onkyo dealer.

**To reset the receiver to its factory defaults, turn it on and, while holding down the CD receiver's Previous [I◀◀] button, press the [⏻ ON/STANDBY] button. When the display indicates "RESET", release the buttons. After a while, the CD receiver will enter standby mode.**

Note that resetting the CD receiver will delete your radio presets and custom settings.

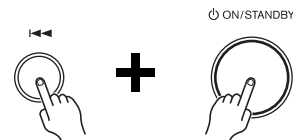

## Power

### Can't turn on the CD receiver.

- Make sure that the power cord is properly plugged into the wall outlet (see page 16).
- Make sure that the power cord is properly plugged into the CD receiver's AC INLET (see page 16).
- Unplug the power cord from the wall outlet, wait 30 minutes or more, then plug it in again.

### The CD receiver turns off unexpectedly.

- If the sleep timer has been set and the SLEEP indicator is shown on the display, the CD receiver will turn off automatically after a specified period (see page 28).
- The CD receiver will automatically enter standby mode when Auto Standby has been set and launches (see page 17).

## Audio

### There's no sound.

- Make sure the CD receiver's volume is not set too low (see page 17).
- Make sure the correct input source is selected (see page 17).
- Make sure the CD receiver is not muted (see page 17).
- Check all connections and correct as necessary (see pages 13 to 15).
- While headphones are connected, the speakers output no sound (see page 17).
- If there's no sound from an external device connected to LINE IN, check whether the external device's audio output level (volume) might be too low.

### The sound quality is not good.

- Make sure the speaker cables are connected with the correct polarity (see page 13).
- Make sure all audio connecting plugs are pushed in all the way (see page 15).
- The sound quality can be affected by strong magnetic fields, such as that from a TV. Try moving any such devices away from the CD receiver.
- If you have any devices that emit high-intensity radio waves near the CD receiver, such as a cellular phone that's being used to make a call, the CD receiver may output noise.
- The CD receiver's precision drive mechanism may emit a faint hissing sound while reading discs during playback or when searching for tracks. You may be able to hear this noise in extremely quiet environments.

### Audio output is intermittent when the CD receiver is subjected to vibration.

- The CD receiver is not a portable device. Use it in a location that's not subject to shock or vibration.
- Make sure that the included cork floor pads are attached to the speakers (see page 6).

### Headphones output is intermittent or there's no sound.

- This may be due to dirty contacts. Clean the headphones plug. See your headphones' instruction manual for cleaning information. Also, make sure that the headphones cable is not broken or damaged.

## Troubleshooting—Continued

### Audio performance.

- Audio performance will be at its best about 10 to 30 minutes after the CD receiver has been turned on and had time to warm up.
- Using cable ties to bundle audio cables with speaker or power cables may degrade the sound quality, so don't do it.

### CD Playback

#### The disc will not play.

- Make sure the disc has been loaded correctly, with the label-side facing up.
- Check to see if the surface of the disc is dirty (see page 12).
- If condensation is suspected, turn on the CD receiver and leave it for 2 to 3 hours before playing any discs.
- Some CD-R/RW discs may not be playable (see page 12).

#### It takes a long time for playback to start.

- It may take the CD receiver a while to read CDs that contain many tracks or files.

#### Playback jumps.

- The CD receiver is being subjected to vibration or the disc is scratched or dirty (see page 13).
- The volume may be too loud. Turn down the volume (see page 17).

#### Can't play MP3 Discs.

- Use only ISO 9660 Level 1 or Level 2 format discs (see page 12).
- The disc has not been finalized. Finalize the disc.
- Check whether the file format is supported (see page 12).
- MP3 files without a “.MP3” or “.mp3” filename extension are not recognized.

### iPod/iPhone/iPad

#### There's no sound.

- Check if “iPod” appears on the display of the CD receiver. If “USB” appears, switch the connection mode to iPod (see page 22).
- Make sure the CD receiver is turned on, the input source is set to iPod, and the volume is not set too low.
- Make sure that your iPod/iPhone/iPad is compatible with the system (see page 7).

#### The message “ERROR” is displayed.

- Try reconnecting your iPod/iPhone/iPad.

#### Can't control your iPod/iPhone/iPad with the CD receiver's remote controller.

- Your iPod/iPhone/iPad may not work soon after it is connected to the CD receiver with a USB cable. In this case, wait a few moments until your iPod/iPhone/iPad wakes up.
- Depending on your iPod/iPhone/iPad model, its software version, or the content you're playing, some functions may not work as expected (see page 22).
- The iPod/iPhone/iPad might not be connected if its power is turned off, or if it is insufficiently charged. Check the state of your iPod/iPhone/iPad.

#### Can't recharge the iPod/iPhone/iPad.

- Check if “iPod” appears on the display of the CD receiver. If “USB” appears, switch the connection mode to iPod (see page 22).
- Check the iPod/iPhone/iPad connection.
- Depending on the state of your iPod/iPhone/iPad, the CD receiver might not be able to charge it. Try using the dedicated charging method provided for the iPod/iPhone/iPad.

## Troubleshooting—Continued

### Bluetooth

#### Bluetooth connection cannot be built.

- When building a Bluetooth connection between the CD receiver and your device for the first time, if the connection is fail, you need to power off your device and power on again to clear the device name, and build the connection again (see page 23).

### USB Flash Drive Playback

#### Can't access the music files on a USB flash drive.

- Check if “USB” appears on the display of the CD receiver. If “iPod” appears, switch the connection mode to USB (see page 26).
- The CD receiver supports USB flash drives only. Note, however, that playback may not be possible with some USB flash drives.
- Make sure that the USB flash drive has been formatted as FAT16 or FAT32.
- USB flash drives with built-in USB hub functionality are not supported.
- This CD receiver cannot play files other than MP3 files.

#### Can't play MP3 files.

- MP3 files without a .MP3 or .mp3 filename extension are not recognized.
- Check whether the file format is supported (see page 12).
- The MP3 file's copyright option is on. Don't use the copyright option.

### Tuner

#### Reception is noisy, stereo FM reception suffers from hiss, the Auto Preset function doesn't preset all stations, or the FM ST indicator doesn't light up when tuned to a stereo FM station.

- Check the antenna connections (see page 13).
- Change the position of the antenna (see page 13).
- Move the CD receiver away from a nearby TV or computer.
- Cars or airplanes can cause noisy interference.
- The radio signal will be weakened if it has to pass through a concrete wall before reaching the antenna.
- Switch to Mono mode and listen in mono. The FM ST indicator will go off (see page 24).
- If none of the above improves the reception, install an outdoor antenna (see page 13).
- When listening to an AM station, noise may be heard when you operate the remote controller.

#### If a power failure occurs or the power cable is disconnected.

- A brief power outage will not cause the contents of memory to be lost. However if the power cable is left disconnected for an extended period of time, only the clock settings (including the timer) will be reset. Please make these settings again as necessary (see pages 24 and 25).

#### Can't adjust the frequency of the radio.

- Use the remote controller's TUNING [◀]/[▶] buttons to change the frequency of the radio (see page 24).

### Remote Controller

#### The remote controller doesn't work properly.

- Replace the battery with a new one.
- The remote controller is too far away from the CD receiver, or there's an obstacle between them (see page 6).
- The CD receiver's remote control sensor is being subjected to bright light (inverter-type fluorescent light or sunlight).
- The CD receiver is located behind the tinted glass doors of an audio rack or cabinet.

## Troubleshooting—Continued

### External Components

#### No sound is heard from your turntable.

- Make sure the turntable has a built-in phono equalizer. If the turntable doesn't have a phono equalizer built-in, you must provide one.

### Timer

#### The timer doesn't work.

- Make sure the clock has been set correctly (see page 26).
- Timed operation will fail if the CD receiver is on at the specified On time, so make sure it's set to Standby (see page 27).
- If you press the [TIMER] button while a timed operation is in progress, the timer will be cancelled.
- The volume setting for timer playback will be the volume that was set before the CD receiver entered standby mode. Set the appropriate volume beforehand.
- If a power failure occurs and the clock stops, the timer will also be reset. Reset the clock, and then make timer settings.

### Clock

#### The display indicates "-- : -" when you press the [CLOCK CALL] button.

- A power failure has occurred, and the clock has stopped. Set the clock again (see page 26).

### Others

#### Standby power consumption.

- Charging will begin when you connect an iPod/iPhone/iPad, causing the power consumption to increase. Charging will occur even if the CD receiver enters standby mode.

Onkyo is not responsible for damages (such as CD rental fees) due to unsuccessful recordings caused by the unit's malfunction. Before you record important data, make sure that the material will be recorded correctly.

The CD receiver contains a microcomputer. In very rare situations, severe interference, noise from an external source, or static electricity may cause it to malfunction or lock up. In the unlikely event that this should happen, unplug the power cord, wait at least 30 minutes, and then plug it back in again. If this doesn't resolve the issue, reset the CD receiver to its factory defaults (see page 29).



# Specifications

## Amplifier

<b>Rated output power</b> All channels:	<b>15 watts minimum continuous power per channel, 6 ohm loads, 2 channels driven at 1 kHz, with a maximum total harmonic distortion of 10% (FTC)</b> 2ch × 15 W (6 Ω, 1 kHz, 2ch driven) (IEC)
THD + N (total harmonic distortion + N)	10 % (Power Rated) 0.5 % (1 kHz 1W)
Damping factor	60 (1 kHz, 8 Ω)
Input sensitivity and impedance	1000 mV/ 47 kΩ (LINE)
Frequency response	40 Hz–20 kHz/+0 dB, –3 dB
Tone control	+10 dB, –10 dB, 100 Hz (BASS) +10 dB, –10 dB, 10 kHz (TREBLE) +4 dB/+8 dB, 80 Hz (S.BASS 1/2)
Signal to noise ratio	84 dB (LINE, IHF-A)
Speaker impedance	6–16 Ω

## Tuner

### ■ FM

Tuning frequency range	87.5–107.9 MHz
Channel presets	30

### ■ AM

Tuning frequency range	530–1710 kHz
Channel presets	30

## CD

Playable media	CD and CD-R/CD-RW (music CDs and MP3 CDs)
----------------	---

## USB

Playable media	USB Flash Drive (MP3)
----------------	-----------------------

## Bluetooth

Version	2.1 + EDR
Profile	A2DP 1.2
Codec	SBC, AAC, aptX

## Speakers D-T05

Type	2 way bass-reflex
Impedance	6 Ω
Maximum input power	30 W
Output sound pressure level	82 dB/W/m
Frequency response	55 Hz–50 kHz
Crossover frequency	4.5 kHz
Cabinet capacity	3.4 liter
Dimensions (W × H × D)	130 × 210 × 172 mm (5-1/8" × 8-1/4" × 6-3/4") (incl. grille and projection)
Weight	1.6 kg (3.5 lbs.)
Driver units	3-15/16" Cone Woofer 3/4" Balanced Dome Tweeter
Terminal	Spring Type Color Coded
Other	Magnetic shielding

## General

Power supply	AC 120 V, 60 Hz
Power consumption	30 W
No-sound Power Consumption	4.3 W (USB/FM/LINE) 7.6 W (CD)
Standby power consumption	0.4 W (when not charging iPod)
Dimensions (W × H × D)	215 × 100 × 270 mm (8-1/2" × 3-15/16" × 10-5/8")
Weight	2.4 kg (5.3 lbs.)
<b>■ Audio input</b>	
Analog input	LINE
<b>■ Audio output</b>	
Analog output	HEADPHONES, SPEAKERS, SUBWOOFER
<b>■ Other</b>	
USB	2.0 HS

Specifications and features are subject to change without notice.

# Memo

---

---

# Memo

---

---

# ONKYO

## Onkyo Corporation

2-1, Nisshin-cho, Neyagawa-shi, OSAKA 572-8540, JAPAN  
Tel: 072-831-8023 Fax: 072-831-8163  
<http://www.onkyo.com/>

## Onkyo U.S.A. Corporation

18 Park Way, Upper Saddle River, N.J. 07458, U.S.A.  
Tel: 800-229-1687, 201-785-2600 Fax: 201-785-2650  
<http://www.us.onkyo.com/>

## Onkyo Europe Electronics GmbH

Liegnitzerstrasse 6, 82194 Groebenzell, GERMANY  
Tel: +49-8142-4401-0 Fax: +49-8142-4208-213  
<http://www.eu.onkyo.com/>

## Onkyo Europe Electronics GmbH (UK Branch)

The Coach House 81A High Street, Marlow, Buckinghamshire, SL7 1AB, UK  
Tel: +44-(0)1628-473-350 Fax: +44-(0)1628-401-700

## Onkyo China Limited

Unit 1033, 10/F, Star House, No 3, Salisbury Road, Tsim Sha Tsui Kowloon, Hong Kong.  
Tel: 852-2429-3118 Fax: 852-2428-9039  
<http://www.onkyochina.com/>

## Onkyo China PRC

1301, 555 Tower, No.555 West NanJin Road, Jin an, Shanghai,  
China 200041, Tel: 86-21-52131366 Fax: 86-21-52130396  
<http://www.cn.onkyo.com/>

SN 29401312

(C) Copyright 2012 Onkyo Corporation Japan. All rights reserved.

Y1206-1



\* 2 9 4 0 1 3 1 2 \*

ENTATIV