



OWNER'S MANUAL

TOSHIBA

4 HEAD VIDEO CASSETTE RECORDER

W525

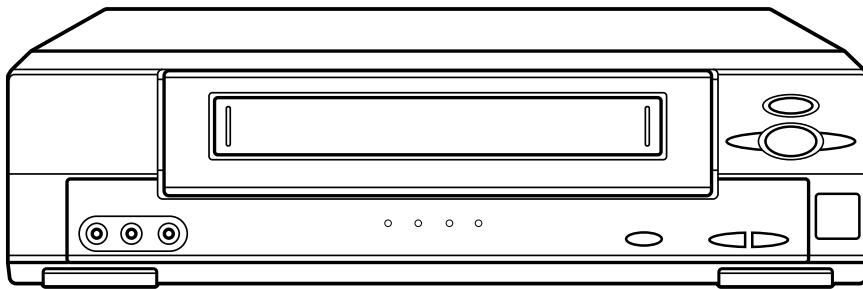

ATTENTION

If you purchase a universal remote control from your local retailer, please contact the remote manufacturer for the required programming code.

TV/CATV MODE SELECTION

When shipped from the factory, the TV/CATV menu option is set to the "CATV" (Cable Television) mode.
If not using CATV (Cable TV), set this menu option to the "TV" mode.



Before operating the unit, please read this manual thoroughly.





	CAUTION RISK OF ELECTRIC SHOCK DO NOT OPEN	
<p>CAUTION: TO REDUCE THE RISK OF ELECTRIC SHOCK, DO NOT REMOVE COVER (OR BACK). NO USER-SERVICEABLE PARTS INSIDE. REFER SERVICING TO QUALIFIED SERVICE PERSONNEL.</p>		



The lightning flash with arrowhead symbol within an equilateral triangle is intended to alert the user to the presence of uninsulated dangerous voltage within the product's enclosure that may be of sufficient magnitude to constitute a risk of electric shock.



The exclamation point within an equilateral triangle is intended to alert the user to the presence of important operating and maintenance (servicing) instructions in the literature accompanying the appliance.

WARNING: TO PREVENT FIRE OR SHOCK HAZARD, DO NOT EXPOSE THIS APPLIANCE TO RAIN OR MOISTURE.

WARNING: This equipment has been tested and found to comply with the limits for a Class B digital device, pursuant to Part 15 of the FCC Rules. These limits are designed to provide reasonable protection against harmful interference in a residential installation. This equipment generates, uses and can radiate radio frequency energy and, if not installed and used in accordance with the instructions, may cause harmful interference to radio communications. However, there is no guarantee that interference will not occur in a particular installation. If this equipment does cause harmful interference to radio or television reception, which can be determined by turning the equipment off and on, the user is encouraged to try to correct the interference by one or more of the following measures:

- Reorient or relocate the receiving antenna.
- Increase the distance between the equipment and receiver.
- Connect the equipment into an outlet on a circuit different from that to which the receiver is connected.
- Consult the dealer or an experienced radio/TV technician for help.

CAUTION: Changes or modifications not expressly approved by the party responsible for compliance with the FCC (Federal Communications Commission) Rules could void the user's authority to operate this equipment.

COPYRIGHT: It is permissible to record television programs, films, video tapes and other material only in the event that third party copyrights and other rights are not violated.

IMPORTANT SAFEGUARDS

1. READ INSTRUCTIONS

All the safety and operating instructions should be read before the unit is operated.

2. RETAIN INSTRUCTIONS

The safety and operating instructions should be retained for future reference.

3. HEED WARNINGS

All warnings on the unit and in the operating instructions should be adhered to.

4. FOLLOW INSTRUCTIONS

All operating and use instructions should be followed.

5. CLEANING

Unplug this unit from the wall outlet before cleaning. Do not use liquid cleaners or aerosol cleaners. Use a damp cloth for cleaning.

6. ATTACHMENTS

The manufacturer of this unit does not make any recommendations for attachments, as they may cause hazards.

2

7. WATER AND MOISTURE

Do not use this unit near water. For example, near a bathtub, washbowl, kitchen sink, or laundry tub, in a wet basement, or near a swimming pool.

8. ACCESSORIES

Do not place this unit on an unstable cart, stand, tripod, bracket, or table. The unit may fall, causing serious injury, and serious damage to the unit.

- 8A.** An appliance and cart combination should be moved with care. Quick stops, excessive force, and uneven surfaces may cause the appliance and cart combination to overturn.

PORTABLE CART WARNING
(symbol provided by RETAC)



S3125A





IMPORTANT SAFEGUARDS

9. VENTILATION

Slots and openings in the cabinet back or bottom are provided for ventilation and to ensure reliable operation of the unit and to protect it from overheating. These openings must not be blocked or covered.

The openings should never be blocked by placing the unit on a bed, sofa, rug, or other similar surface.

This unit should never be placed near or over a radiator or heat source. This unit should not be placed in built-in installation such as a bookcase or rack unless proper ventilation is provided or the manufacturer's instructions have been adhered to.

10. POWER SOURCES

This unit should be operated only from the type of power source indicated on the rating plate. If you are not sure of the type of power supply to your home, consult your appliance dealer or local power company. For units intended to operate from battery power, or other sources, refer to the respective pages on this Owner's Manual for their operating instructions.

11. GROUNDING OR POLARIZATION

This unit is equipped with a polarized alternating-current line plug (a plug having one blade wider than the other). This plug will fit into the power outlet only one way. This is a safety feature. If you are unable to insert the plug fully into the outlet, try reversing the plug. If the plug should still fail to fit, contact your electrician to replace your obsolete outlet. Instead of the polarized alternating-current line plug, your unit may be equipped with a 3-wire grounding-type plug (a plug having a third (grounding) pin). This plug will only fit into a grounding-type power outlet. This too, is a safety feature. If you are unable to insert the plug into the outlet, contact your electrician to replace your obsolete outlet.

Do not defeat the safety purpose of the grounding-type plug.

12. POWER-CORD PROTECTION

Power-supply cords should be routed so that they are not likely to be walked on or pinched by items placed upon or against them, paying particular attention to cords at plugs, convenience receptacles, and the point where they exit from the appliance.

13. LIGHTNING

To protect your unit from a lightning storm, or when it is left unattended and unused for long periods of time, unplug it from the wall outlet and disconnect the antenna or cable system. This will prevent damage to the unit due to lightning and power line surges.

14. POWER LINES

An outside antenna system should not be located in the vicinity of overhead power lines or other electric light or power circuits, or where it can fall onto or against such power lines or circuits. When installing an outside antenna system, extreme care should be taken to keep from touching such power lines or circuits, as contact with them might be fatal.

15. OVERLOADING

Do not overload wall outlets and extension cords, as this can result in a risk of fire or electric shock.

16. OBJECT AND LIQUID ENTRY

Do not push objects through any openings in this unit as they may touch dangerous voltage points or short out parts that could result in fire or electric shock. Never spill or spray any type of liquid into the unit.

17. OUTDOOR ANTENNA GROUNDING

If an outside antenna or cable system is connected to the unit, be sure the antenna or cable system is grounded to provide some protection against voltage surges and built-up static charges. Section 810 of the National Electrical Code (NEC) ANSI/NFPA 70, provides information with respect to proper grounding of the mast and supporting structure, grounding of the lead-in wire to an antenna discharge unit, size of grounding conductors, location of antenna discharge unit, connection to grounding electrodes, and requirements for the grounding electrode.

18. SERVICING

Do not attempt to service this unit yourself as opening or removing covers may expose you to dangerous voltage or other hazards. Refer all servicing to qualified service personnel.



IMPORTANT SAFEGUARDS

For example:

- a. When the power-supply cord or plug is damaged.
- b. If liquid has been spilled, or objects have fallen into the unit.
- c. If the unit has been exposed to rain or water.
- d. If the unit does not operate normally by following the operating instructions. Adjust only those controls that are covered by the operating instructions, as an improper adjustment of other controls may result in damage and will often require extensive work by a qualified technician to restore the unit to its normal operation.
- e. If the unit has been dropped or the cabinet has been damaged.
- f. When the unit exhibits a distinct change in performance, this indicates a need for service.

19. REPLACEMENT PARTS

When replacement parts are required, be sure the service technician uses replacement parts specified by the manufacturer or those that have the same characteristics as the original parts. Unauthorized substitutions may result in fire, electric shock or other hazards.

20. SAFETY CHECK

Upon completion of any service or repairs to this unit, ask the service technician to perform safety checks to determine that the unit is in proper operating condition.

21. HEAT

The product should be situated away from heat sources such as radiators, heat registers, stoves, or other products (including amplifiers) that produce heat.

22. NOTE TO CATV SYSTEM INSTALLER

This reminder is provided to call the CATV system installer's attention to Article 820-40 of the NEC that provides guidelines for proper grounding and, in particular, specifies that the cable ground shall be connected to the grounding system of the building, as close to the point of cable entry as practical.

EXAMPLE OF ANTENNA GROUNDING AS PER THE NATIONAL ELECTRICAL CODE

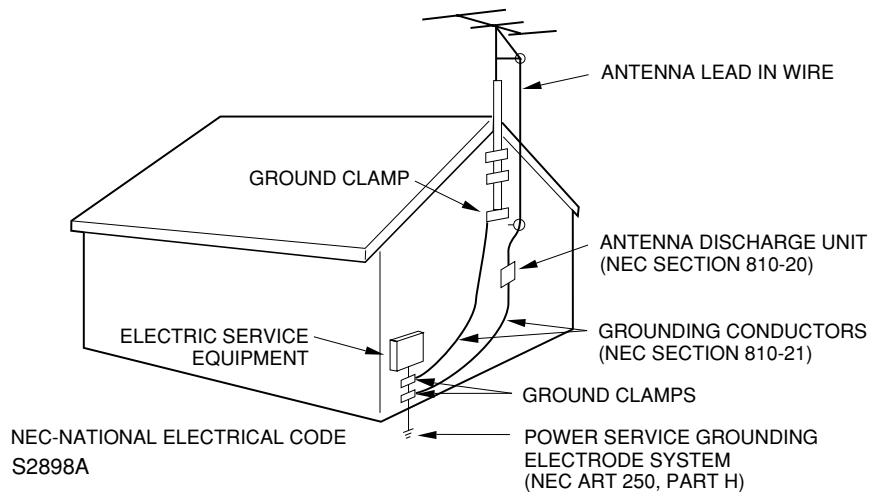



PRECAUTIONS

- If you cause a static discharge when touching the VCR, and the VCR fails to function, simply unplug the unit from the wall outlet, wait 10 minutes and plug it back in. The VCR should return to normal operation.
- Avoid extreme heat or cold. (41°F/5°C-104°F/40°C)
- Do not place the VCR on or near appliances which may cause electromagnetic interference, e.g. TV, speakers, etc. Doing so may cause erratic operation of the VCR including picture and/or sound distortion or noise.
- Avoid extreme moisture and dust.
- The ventilation holes prevent overheating. Do not block or cover these holes. Especially avoid covering the holes with soft materials such as cloth or paper.
- Do not insert fingers or any other objects into the cassette loading slot. Do not spray cleaner or wax directly on the VCR or use forced air to remove dust.
- Avoid places subject to strong vibration. Use in a horizontal (flat) position only.
- Keep the VCR away from flower vases, sinks, etc. If liquids should be spilled into the VCR, serious damage will result. If you spill any liquids into the VCR, unplug the AC power cord immediately and consult qualified service personnel before attempting to use the VCR again.
- When you finish operating the VCR, always unload the cassette and turn off the power.
- When you leave your home for a long time, unplug the AC power cord.
- To protect the VCR from a lightning storm, unplug the AC power cord from the wall outlet and disconnect the antenna.

MOISTURE CONDENSATION

DO NOT OPERATE THIS VCR FOR AT LEAST THREE HOURS WHEN MOISTURE IN THE AIR CONDENSES ON THE VCR.

WHAT IS MOISTURE CONDENSATION?

When a cold liquid is poured into a glass, for example, water vapor in the air will condense on the surface of the glass. This is called moisture condensation.

MOISTURE WILL CONDENSE ON THE UNIT IN THE FOLLOWING CASES;

- When you move this VCR from a cold to a warm place.
- After heating a cold room or under extremely humid conditions.

WHEN YOU EXPERIENCE THE ABOVE CONDITIONS, Plug the power cord into an AC outlet, press the POWER button to turn on and leave the unit at room temperature until moisture condensation disappears. Depending on the surrounding conditions, this may take two or three hours.

POWER SOURCE

TO USE AC POWER SOURCE

Use the AC polarized line cord provided for operation on AC. Insert the AC cord plug into a standard 120V 60Hz polarized AC outlet.

NOTES:

1. Never connect the AC line cord plug to other than the specified voltage (120V 60Hz). Use the attached power cord only.
2. If the polarized AC cord does not fit into a non-polarized AC outlet, do not attempt to file or cut the blade. It is the user's responsibility to have an electrician replace the obsolete outlet.

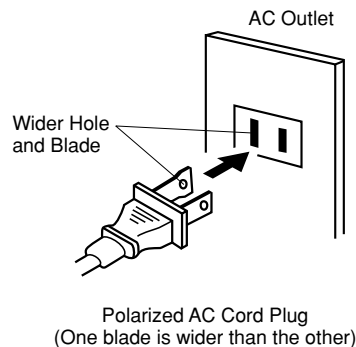



PRECAUTIONS

BATTERY CAUTIONS

Follow these precautions when using batteries in this device:

- Use only the size and type of batteries specified.
- Be sure to follow the correct polarity when installing the batteries as indicated in the battery compartment. Reversed batteries may cause damage to the device.
- Do not mix different types of batteries together (e.g. Alkaline and Carbon-zinc) or old batteries with fresh ones.
- If the device is not to be used for a long period of time, remove the batteries to prevent damage or injury from possible battery leakage.
- Do not try to recharge batteries not intended to be recharged; they can overheat and rupture (Follow battery manufacturer's directions).

BATTERY INSTALLATION

- Open the battery compartment cover.
- Install two "AAA" batteries.
- Replace the cover.

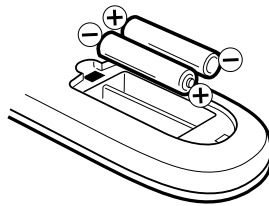

EFFECTIVE DISTANCE OF THE REMOTE CONTROL

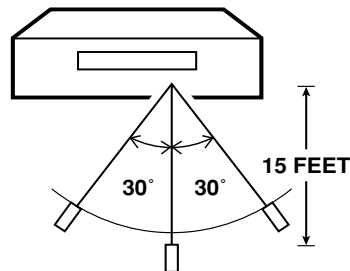

- NOTES:**
- When direct sunlight, an incandescent lamp, fluorescent lamp or any other strong light shines on the Remote Sensor, the remote operation may be unstable.
 - When there is an obstacle between the VCR and the remote control, the remote control may not operate.

6

FEATURES

High Quality Picture Technology - This video cassette recorder marked "HQ" incorporates VHS high quality technology. A built-in detail enhancer is used to boost the recorded signal and provide maximum picture quality in playback. It is compatible with other VHS video cassette recorders.

4 Video Heads - Provides optimal picture quality for special effects playback.

8-Program/1-Month Programmable Timer with Everyday/Every Week Capability - The built-in timer allows automatic absentee recording of up to 8 TV programs within 1 month. It is also possible to record a program which is broadcast at the same time everyday or every week.

On-Screen Display and Programming - When you select a channel or make other changes, the TV will show an indicator on the screen for a few seconds. Clock settings, timer setting and other set-up operations can be carried out using the on-screen display menu system.

Digital Auto Tracking - Automatically adjusts tracking during playback for the best possible picture.

181 Channel Tuner - Receives standard VHF and UHF broadcast channels and up to 113 cable channels.

One-touch Timer Recording (OTR) - Simply by pressing the REC button, the VCR can be programmed for up to 5 hours of recording with an immediate start.

Automatic Power On - When loading a cassette tape, this VCR will automatically turn on.

Automatic Playback - When loading a cassette tape without the erase prevention tab, this VCR will automatically turn on and play back the cassette tape at the correct speed.

Automatic Rewind-Stop-Eject-Power Off - When a tape reaches its end during playback and recording, it will automatically stop, rewind, stop, eject the tape and the VCR will turn off.



TABLE OF CONTENTS

CAUTIONS

IMPORTANT SAFEGUARDS	2
PRECAUTIONS	5

PREPARATION

FEATURES	6
LOCATION OF CONTROLS	8
BASIC CONNECTIONS	10
CATV (CABLE TV) CONNECTIONS	12
AUDIO/VIDEO CONNECTIONS	14
SETTING THE VIDEO CHANNEL	15
LANGUAGE SELECTION	15
SETTING THE CLOCK	15
SETTING THE CHANNELS	16
NOISE ELIMINATION	16

PLAYBACK

LOADING AND UNLOADING	17
PLAYBACK	17
SPECIAL PLAYBACK	18

RECORDING

RECORDING A TV PROGRAM	18
ONE-TOUCH TIMER RECORDING (OTR)	20
SETTING THE TIMER RECORDING	20

ADDITIONAL INFORMATION

ON-SCREEN FUNCTION DISPLAY	21
DUPLICATING A VIDEO TAPE	22
VIDEO HEAD CLEANING	23
BEFORE REQUESTING SERVICE	24
SPECIFICATIONS	25
WARRANTY	26

Automatic Repeat Play System - When the AUTO REPEAT option is turned on, this VCR will automatically play back the same cassette tape repeatedly.

On-Screen 3 Language Display - This TV can display the on screen language in English, Spanish or French.

Slow Motion - This VCR provides slow motion which offers steady, noise free playback at 1/10 normal speed.

Frame by Frame Advance - Press the SLOW button during still playback to advance the tape one frame at a time.

Real Time Tape Counter - The counter displays on the screen the elapsed time in hours, minutes and seconds and can be used to locate programs.

2 Speed Picture Search - 3 or 5 times normal speed in SP mode (7X or 9X in LP and 9X or 15X in SLP).

3 Speed Playback - Plays three tape speeds (SP, LP, SLP).

2 Speed Record - Records two tape speeds (SP, SLP).

Front Audio/Video In Jacks - A VCR or other video device may be hooked up for dubbing.



LOCATION OF CONTROLS

FRONT

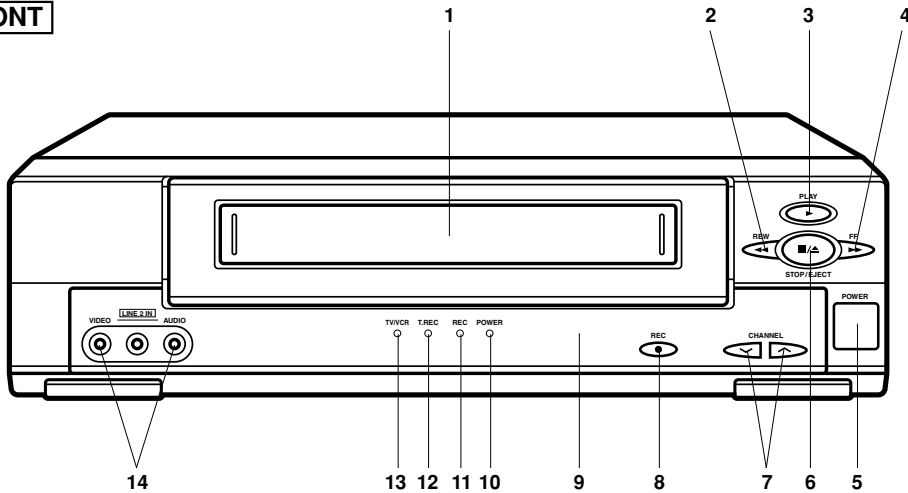

REMOTE CONTROL

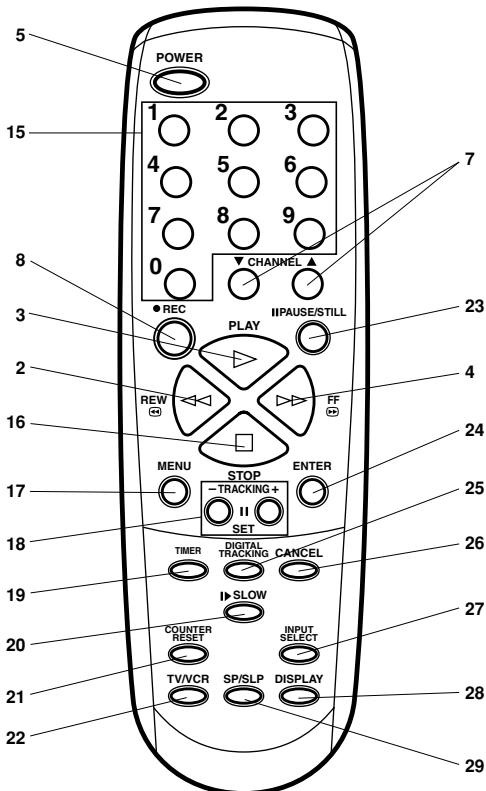

- 1. Cassette Loading Slot** - To insert or remove a video tape.
- 2. REW button** - In the STOP mode, this button rapidly winds the tape backwards. In the PLAY mode, this button activates Reverse Search.
- 3. PLAY button** - Press to play a prerecorded tape.
- 4. FF button** - In the STOP mode, this button rapidly winds the tape forward. In the PLAY mode, this button activates Forward Search.
- 5. POWER button** - Turns the VCR power on and off.
- 6. STOP/EJECT button** - Press once to stop the tape in any mode. Press again to eject the tape.
- 7. CHANNEL ∇ / \blacktriangle buttons** - Used to select a channel for viewing or recording.
- 8. REC button** - Press once to start normal recording. Additional presses activate One-touch Timer Recording.
- 9. Remote Sensor** - Signals from the Remote Control are received here.
- 10. POWER indicator** - Lights up when the power is turned on.
- 11. REC indicator** - Lights up during recording.
- 12. T. REC indicator** - Lights when the unit is in the Timer Record mode.
- 13. TV/VCR indicator** - Lights up when the TV/VCR selector button is selected to the VCR mode.
- 14. AUDIO/VIDEO IN (LINE 2) Jacks** - Audio and video signal cables from an external source can be connected here.

8



REAR

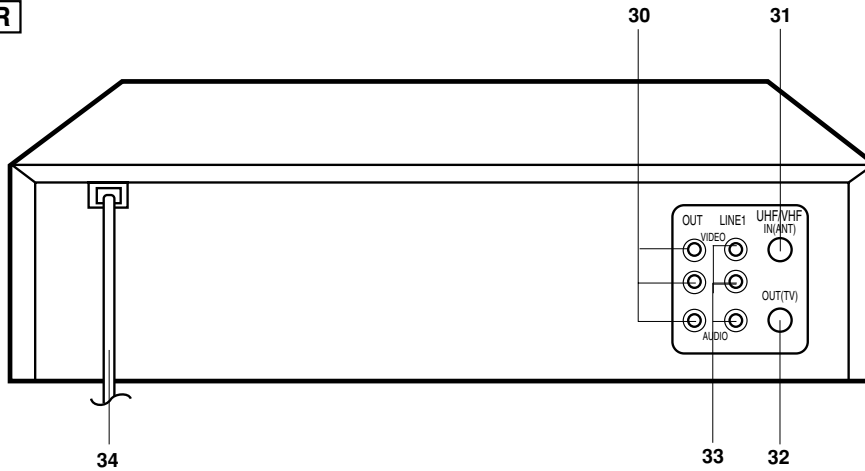

- 15. **Direct Channel Selection buttons (0-9)** - Allows direct access to any channel.
- 16. **STOP button** - Press to stop the tape.
- 17. **MENU button** - Press to display the on-screen menu function.
- 18. **TRACKING SET +/- buttons** - During playback, they are used to adjust tracking manually. Used to set or adjust in the menu mode.
- 19. **TIMER button** - Used to set the VCR to start recording at a preset time.
- 20. **SLOW button** - Press to play back a tape in slow motion or to advance the tape one frame at a time during still playback.
- 21. **COUNTER RESET button** - Resets the Real Time Tape Counter to 00:00:00.
- 22. **TV/VCR selector button** - Switches between TV and VCR.
- 23. **PAUSE/STILL button** - During recording, this button temporarily stops the tape. The "●■" will appear on the screen. During playback, it stops the tape and displays a still image on the TV screen.
- 24. **ENTER button** - Used to enter the information in the menu mode.
- 25. **DIGITAL TRACKING button** - Allows automatic adjustment of tracking to minimize picture noise during playback.
- 26. **CANCEL button** - Used to clear the selected timer recording program.
- 27. **INPUT SELECT button** - Switches the program for viewing between the VCR and external input sources.
- 28. **DISPLAY button** - Displays the present time/day of the week, channel, counter, speed selection and VCR mode on the TV screen.
- 29. **SP/SLP selector button** - Sets the tape speed for recording.
- 30. **AUDIO VIDEO OUT Jacks** - Use to output audio and video signal to a TV, amplifier or VCR.
- 31. **UHF/VHF IN (ANT) Jack** - Connect a UHF/VHF antenna or CATV cable to this jack.
- 32. **UHF/VHF OUT (TV) Jack** - Use to output UHF/VHF or CATV signal to a TV.
- 33. **AUDIO/VIDEO IN (LINE1) Jacks** - Audio and video signal cables from an external source can be connected here.
- 34. **AC Power Cord** - Connect to a 120V 60Hz outlet.



BASIC CONNECTIONS

If you are using an antenna system, follow the instructions. If you are a cable (CATV) subscriber, skip ahead to page 12 for the proper connections.

ANTENNA TO VCR CONNECTION

The VCR must be connected "between" the antenna and the TV. First, disconnect the antenna from the TV and connect it to the VCR. Then connect the VCR to the TV. Below are 3 common methods of connecting an antenna system to a VCR. Find the type of antenna system you are using and follow the connection diagram.

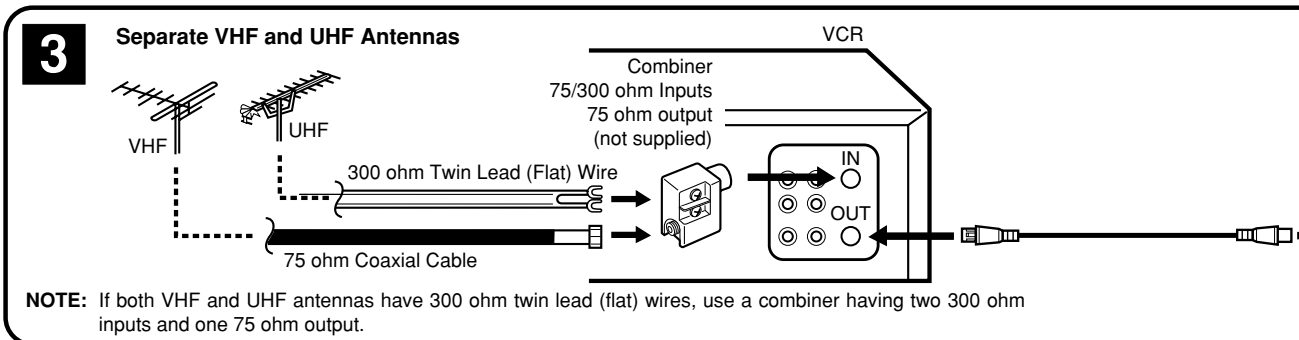
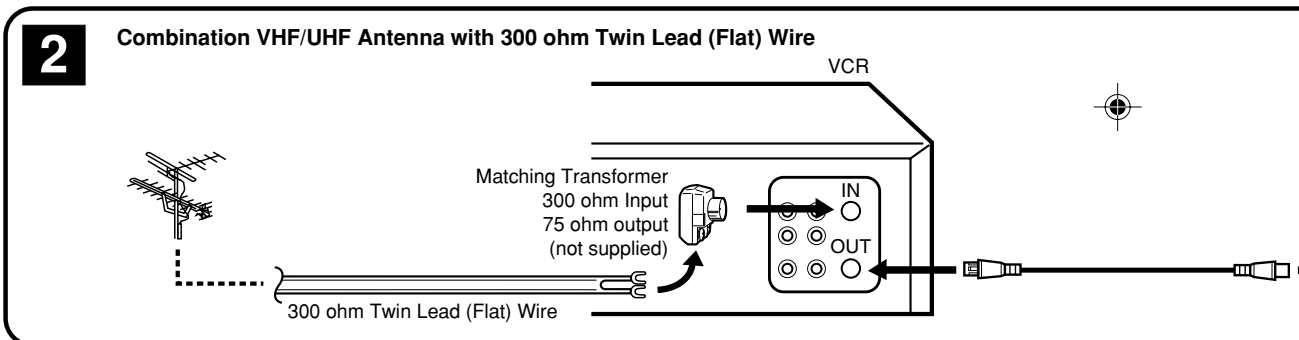
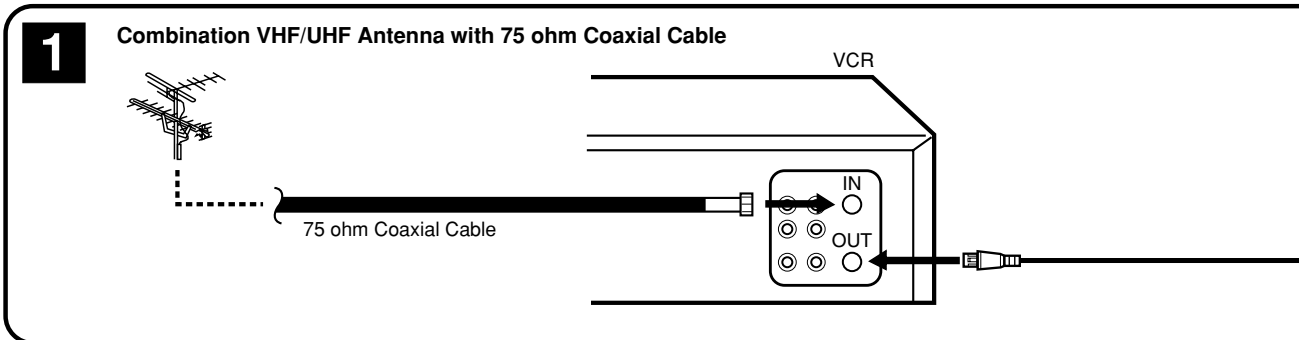

NOTE: If both VHF and UHF antennas have 300 ohm twin lead (flat) wires, use a combiner having two 300 ohm inputs and one 75 ohm output.

- NOTES:**
- A clear picture will not be obtained by the VCR unless the antenna signal is good. Connect the antenna to the VCR properly.
 - For better quality recording, an indoor antenna or a telescopic antenna is not recommended. The use of an outdoor type antenna is required.
 - If you are not sure about the connection, please refer to qualified service personnel.





VCR TO TV CONNECTION

After you have connected the antenna to the VCR, you must connect the VCR to the TV. Below are 3 common methods of connecting your VCR to a TV. Find the type of TV you are using and follow the connection diagram.

This VCR has a single 75 ohm output for connection to a TV. If your TV has separate VHF and UHF antenna inputs (numbers 2 and 3 below), use a splitter to connect the VCR to the TV for VHF and UHF reception.

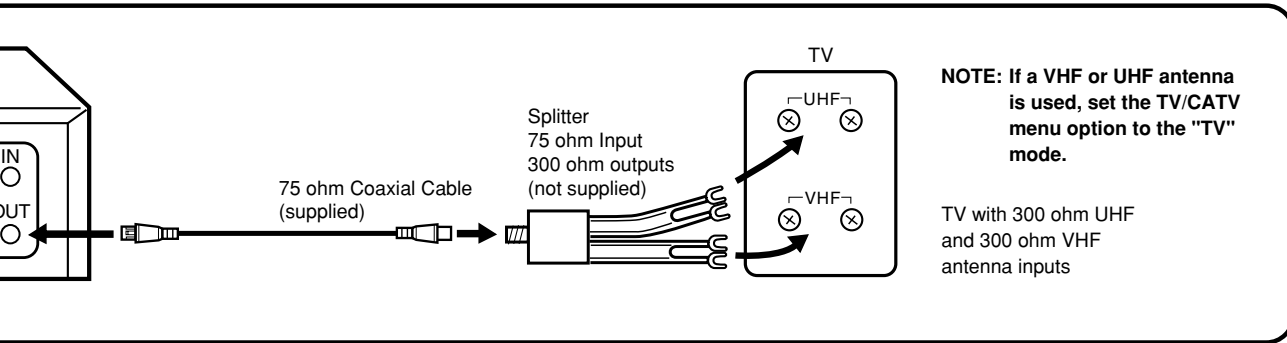
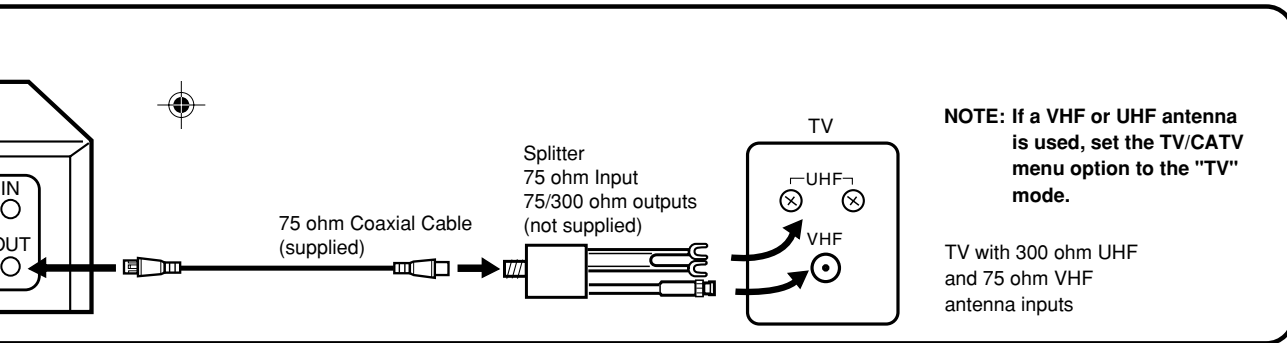
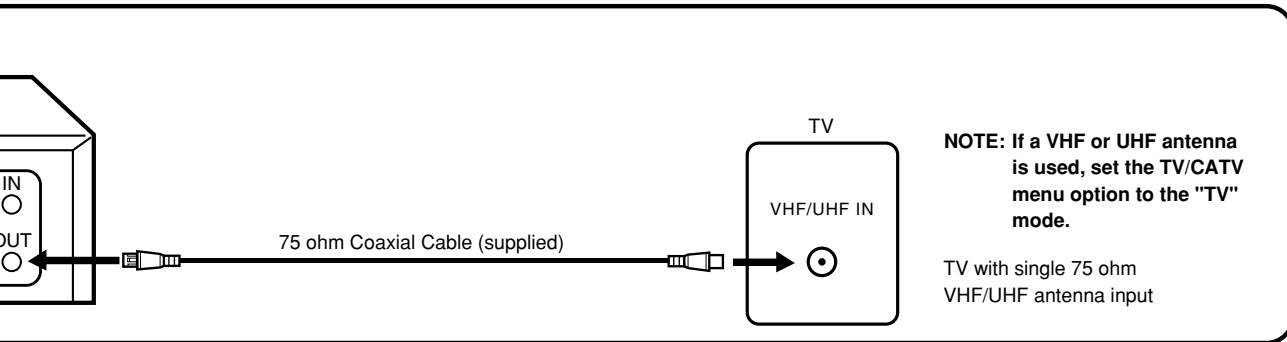



CATV (CABLE TV) CONNECTIONS

Many cable companies offer services permitting reception of extra channels including pay or subscription channels. This VCR has an extended tuning range and can be tuned to most cable channels without using a cable company supplied converter box, except for those channels which are intentionally scrambled. If you subscribe to a special channel which is scrambled, you must have a descrambler box for proper reception.

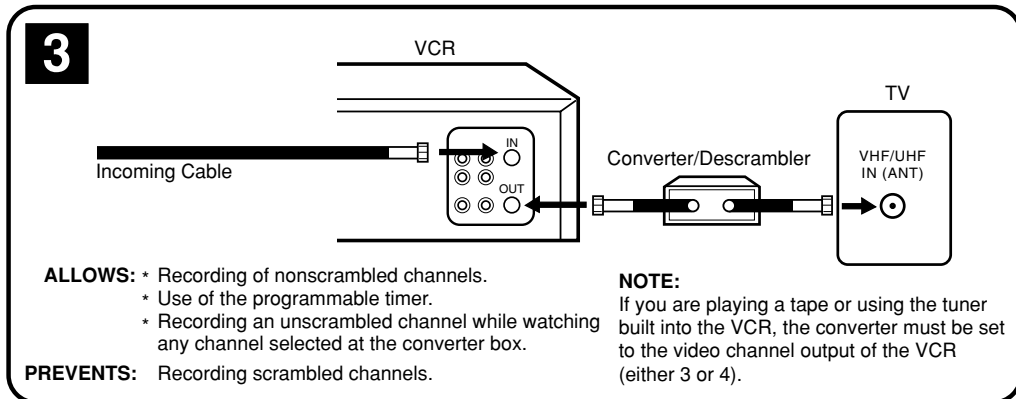
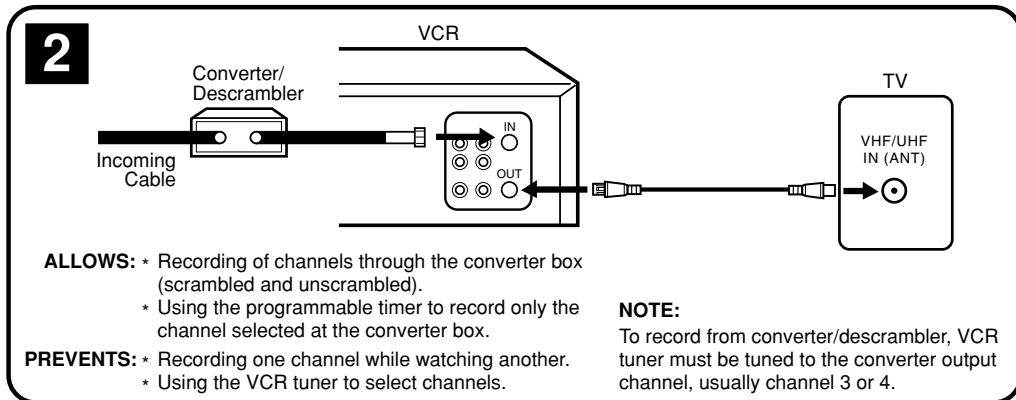
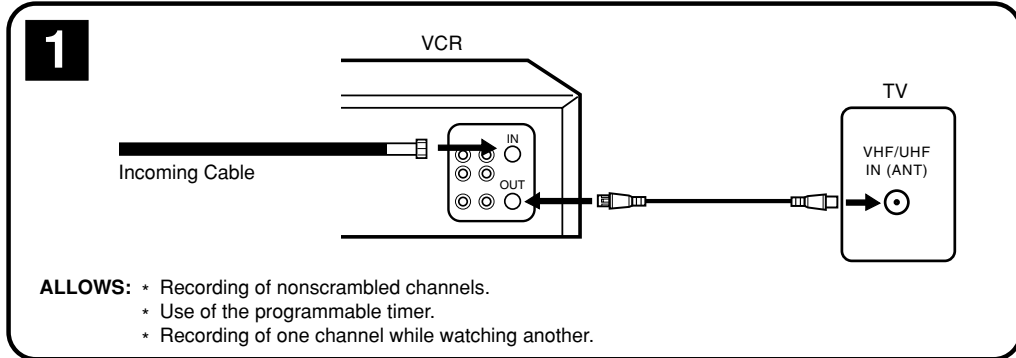

NOTE: Whenever a Converter/Descrambler box is placed before the VCR, you must tune the VCR to the output of the Converter/Descrambler box, usually channel 3 or 4.





IMPORTANT: Make sure the TV/CATV menu option is set to the "CATV" mode.

This VCR cannot receive scrambled programs since it does not contain a descrambler. In order to receive scrambled programs, your existing descrambler must be used. Descrambler boxes are available from cable companies. Consult your local cable company for more information concerning connection to their descrambler equipment. There are many ways to connect your VCR to a cable system. Below are six common methods of connection.

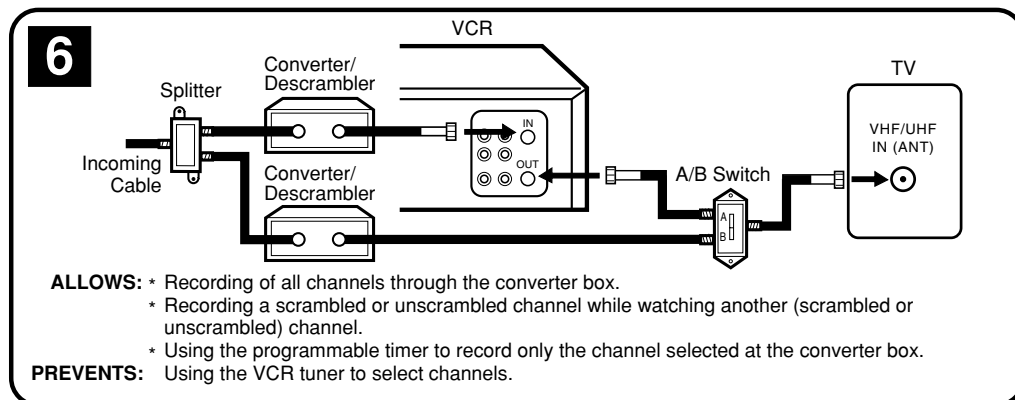
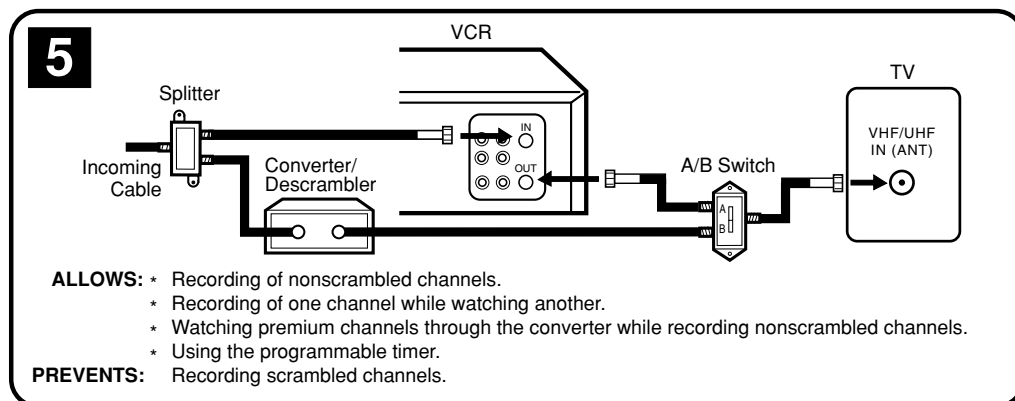
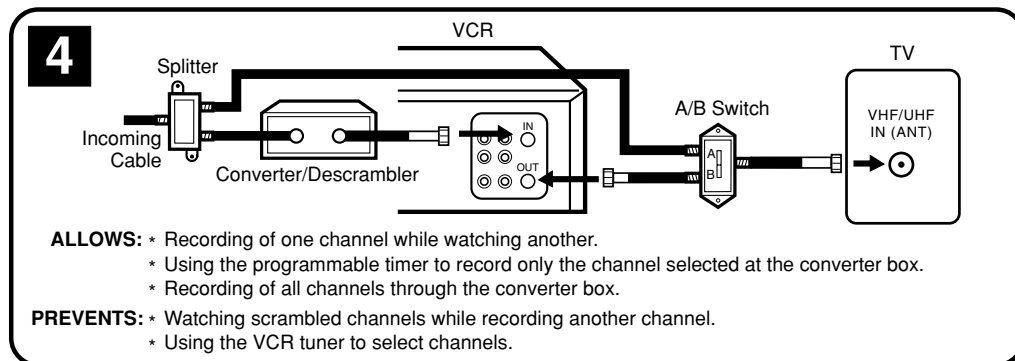



AUDIO/VIDEO CONNECTIONS

If your TV has AUDIO IN and VIDEO IN jacks, you can connect your VCR to them to receive a higher quality picture and sound. If you have a stereo, you can connect a stereo amplifier to enjoy powerful sound.

AUDIO/VIDEO CONNECTION

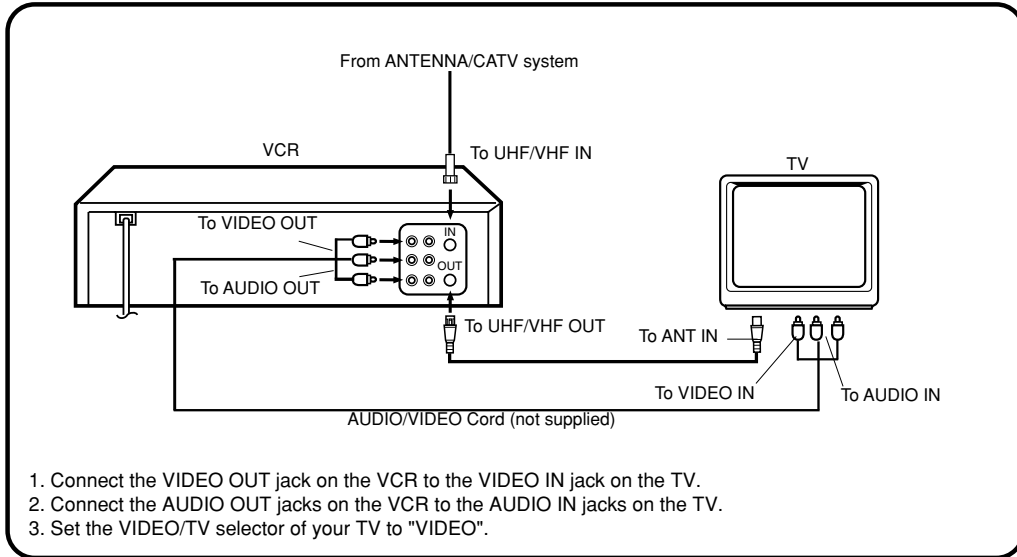

STEREO AMPLIFIER CONNECTIONS

When you connect your VCR to a Stereo Component System, you can view the picture from the VCR while enjoying powerful sound from your audio system.

NOTE: Sound will be monaural.

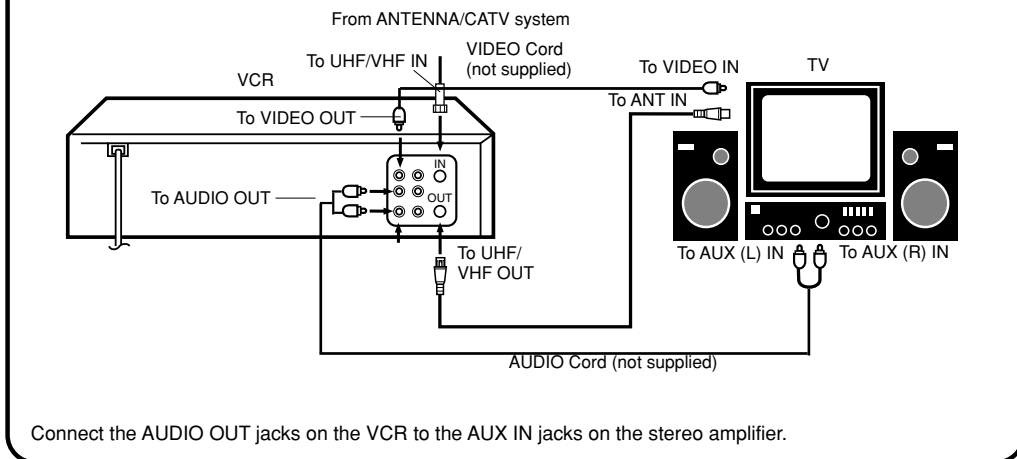



SETTING THE VIDEO CHANNEL

To view playback of a recorded tape, or to watch a program selected by the VCR's channel selector, the TV must be set to channel 3 or 4 (video channel).

When a TV is connected with the 75 ohm coaxial cable only.

- 1 During power off, press and hold the "3" or "4" number button on the remote control for 3 seconds. The "TV/VCR" indicator will flash 4 times.
- 2 Turn ON the VCR POWER button.
- 3 Turn ON the TV and set to CH 3 or 4 to correspond with the channel selected in step 1.
- 4 Press the TV/VCR selector button to select the VCR position. The TV/VCR indicator will light.
- 5 Select any channel to receive a TV station in your area. The channel number will appear on the screen for about 4 seconds.

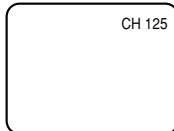

For a push-button TV tuner

If CH 3 or 4 corresponding to the video channel cannot be tuned on your TV, proceed as follows: set the VCR 3/4 channel selector and the TV to CH 3 or 4, play back a prerecorded tape and tune the TV to receive a sharp color picture from the video cassette recorder. Refer to your TV owner's manual for details.

LANGUAGE SELECTION

This VCR can display on the TV screen in the English, Spanish or French languages.

CHECK BEFORE YOU BEGIN

- Turn ON the TV and set to the video channel 3 or 4.
- Turn ON the VCR POWER button.
- Press the TV/VCR selector button to select the VCR mode.

When a TV is connected with an audio/video cable, turn the TV and this VCR on and select the video input mode on the TV.

- 1 Press the MENU button. Press the TRACKING SET + or - button to select the LANGUAGE option, then press the ENTER button.

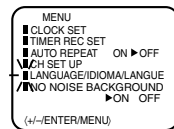

- 2 Press the TRACKING SET + or - button to select the desired language: English (ENGLISH), Spanish (ESPAÑOL) or French (FRANCAIS), then press the ENTER button.

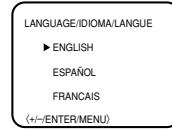

- 3 Press the MENU button until the menu screen is cleared.

SETTING THE CLOCK

You must set the date and time manually for timer recordings.

EXAMPLE: Setting the clock to "8:30 AM" March, 29 (FRI), 2002.

CHECK BEFORE YOU BEGIN

- Turn ON the TV and set to the video channel 3 or 4.
- Turn ON the VCR POWER button.
- Press the TV/VCR selector button to select the VCR mode.

When a TV is connected with an audio/video cable, turn the TV and this VCR on, and select the video input mode on the TV.

- 1 Press the MENU button. Press the TRACKING SET + or - button to select the CLOCK SET option, then press the ENTER button.

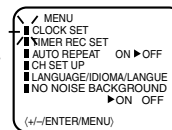

- 2 Press the TRACKING SET + or - button to set the month, then press the ENTER button.

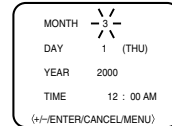

- 3 Set the day, year and time as in Step 2.

- The day of the week will automatically appear when you set the year.
- Press and hold down the button to increase/ decrease the minute by 10.
- Auto date and time start functioning when you finish setting.

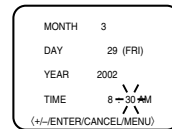

NOTES: • After a power failure or disconnection of the power, the timer settings will be lost. In this case, reset the present time.

- Press the CANCEL button to move cursor backward for correction.
- If you want to correct time or date while the clock is functioning, press the MENU button, then press TRACKING SET + or - button to select the CLOCK SET option, then press the ENTER button. To make any adjustments perform steps 2 through 3.





SETTING THE CHANNELS

This VCR is equipped with a channel memory feature which allows channels to skip up or down to the next channel set into memory, skipping over unwanted channels. Before selecting channels, they must be programmed into the VCR's memory. In addition to normal VHF and UHF channels, this VCR can receive up to 113 Cable TV channels. To use this VCR with an antenna, set the TV/CATV menu option to the TV mode. When shipped from the factory, this menu option is in the CATV mode.

TV/CATV SELECTION

- 1 Press the MENU button.
- 2 Press the TRACKING SET + or - button to select the CH SET UP option, then press the ENTER button.
- 3 Press the TRACKING SET + or - button to select the TV/ CATV mode.
- 4 Press the ENTER button to select the TV or CATV mode. The arrow indicates the selected mode.

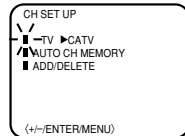
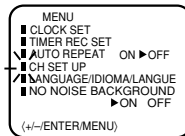

TV - VHF/UHF channels
CATV - CABLE TV channels

- 5 Press the MENU button twice to return to normal TV viewing.

AUTOMATIC MEMORY TUNING

The VCR can receive a maximum of 181 channels by presetting the channels into memory.

CHECK BEFORE YOU BEGIN

- Turn ON the TV and set to the video channel 3 or 4.
- Turn ON the VCR POWER button.
- Press the TV/VCR selector button to select the VCR mode.

When a TV is connected with an audio/video cable, turn the TV and this VCR on, and select the video input mode on the TV.

- 1 Press the MENU button. Press the TRACKING SET + or - button to select the CH SET UP option, then press the ENTER button.
- 2 Press the TRACKING SET + or - button to select the AUTO CH MEMORY mode, then press the ENTER button.
- 3 The auto tuning will start. The channel display will count up and when finished, the screen returns to normal.

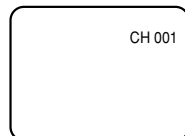
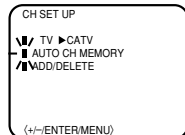
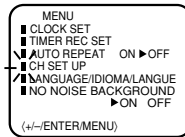

16

TO ADD/DELETE CHANNELS

- 1 Press the MENU button. Press the TRACKING SET + or - button to select the CH SET UP option, then press the ENTER button.
- 2 Press the TRACKING SET + or - button to select the ADD/DELETE mode, then press the ENTER button.
- 3 Select the desired channels to be added or deleted using the TRACKING SET + or - button.
- 4 Press the ENTER button if you wish to DELETE the channel from memory. Press the ENTER button if you wish to ADD the unmemorized channel. Repeat Steps 3 and 4 for each channel to be added or deleted.
- 5 Press the MENU button three times after adding or deleting all of the desired channels, to return to normal TV viewing.

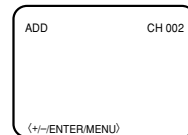
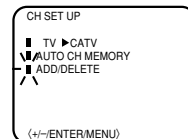
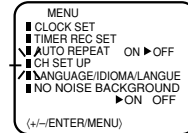

NOISE ELIMINATION

When you don't want to receive a weak signal broadcast, the Blue back screen can be obtained by selecting the NO NOISE BACKGROUND "ON". When the unit is shipped from the factory, the NO NOISE BACKGROUND is set to the "ON" position.

CHECK BEFORE YOU BEGIN

- Turn ON the TV and set to the video channel 3 or 4.
- Turn ON the VCR POWER button.
- Press the TV/VCR selector button to select the VCR mode.

When a TV is connected with an audio/video cable, turn the TV and this VCR on and select the video input mode on the TV.

- 1 Press the MENU button, then press the TRACKING SET + or - button to select the NO NOISE BACKGROUND option.
- 2 Press the ENTER button to select the ON position.
- 3 Press the MENU button again.

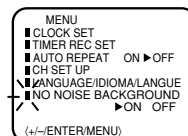
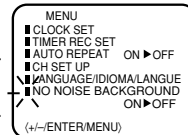



LOADING AND UNLOADING

Use only video cassette tapes marked **VHS**.

LOADING

Push the center of the tape until it is automatically retracted.

AUTOMATIC POWER ON

The VCR will turn on automatically and the POWER indicator will light.

AUTOMATIC PLAY

When loading a cassette tape without the erase prevention tab, playback will start immediately. Insert the cassette with its labeled side facing you. An inverted cassette cannot be inserted.

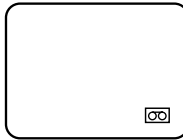

TO STOP PLAYBACK

Press the STOP button once.

The tape will stop but remain fully loaded and ready to play.

"■" will appear on the screen for about 4 seconds.



This VCR selects the playback tape speed SP, LP or SLP automatically.

TO REWIND OR FORWARD THE TAPE RAPIDLY

Press the REW button in the STOP mode.

"◀◀" will appear on the screen for about 4 seconds.



Press the FF button in the STOP mode.

"▶▶" will appear on the screen for about 4 seconds.



UNLOADING

To unload a cassette, press the STOP/EJECT button on the VCR twice. The first press will stop the tape in any mode. The second press will eject the tape. "▲" will appear on the screen for about 4 seconds.



AUTOMATIC EJECT

If the VCR automatically rewinds the tape to the beginning (AUTO REWIND FEATURE), the tape will be ejected automatically (See the NOTE on page 19).

- NOTES:**
- Always eject the tape when not in use.
 - The cassette can be ejected even if the VCR is turn off.

FORWARD/REVERSE PICTURE SEARCH

If you want to see the tape program during REW or FF mode, press and hold the REW or FF button again. The backward or forward visual search picture will be seen on the screen. Release the button to return to the REW or FF mode.

PLAYBACK

To play a prerecorded cassette tape.

TO START PLAYBACK

CHECK BEFORE YOU BEGIN

Turn ON the TV and set to the video channel 3 or 4.

When a TV is connected with an audio/video cable, turn the TV and this VCR on and select the video input mode on the TV.

- 1 Load a prerecorded tape (When loading a cassette tape without the erase prevention tab, playback will start automatically).

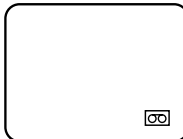

- 2 Press the PLAY button. Playback will start. "▶" will appear on the screen for about 4 seconds.

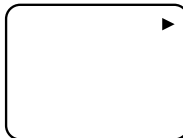

DIGITAL TRACKING CONTROL

When a tape is played, the Digital Auto Tracking System automatically adjusts the tracking to obtain the best possible picture. If noise bars appear during playback, adjust the tracking manually:

- Press the TRACKING SET + or – button to obtain the best possible picture. To resume automatic tracking, press the DIGITAL TRACKING button.



SPECIAL PLAYBACK

TO VISUALLY SEARCH FOR DESIRED POINTS

When either the FF or REW button is pressed in the PLAYBACK mode, the speed search picture will appear. When pressed twice, the search picture will increase speed. Speed search time depends upon the speed used (SP, LP or SLP) during recording.

TO WATCH A STILL PICTURE

Press the PAUSE/STILL button in the PLAYBACK mode. Press the PAUSE/STILL button again to resume normal playback.

FRAME BY FRAME ADVANCE

Press the SLOW button during STILL playback. The still picture will advance by one frame each time you press the button. Hold the button for continuous frame by frame viewing. Press the PAUSE/STILL button again to resume normal playback.

- NOTES:**
- A few noise bars will appear on the picture during SPEED SEARCH and STILL.
 - The audio output is muted during SPEED SEARCH, STILL, FRAME ADVANCE and SLOW MOTION.
 - To prevent damage to the tape, special playback is automatically changed to the PLAYBACK mode after 5 minutes.

SLOW MOTION PLAYBACK

Press the SLOW button in the PLAYBACK mode. Playback will proceed at 1/10th of the normal speed. Press the PLAY button again to resume normal playback.

NOTE: SLOW TRACKING AND VERTICAL LOCK ADJUSTMENT

If noise bars appear in the picture during slow motion, press the TRACKING SET + or – button to reduce the noise bars.

If the still picture jitters excessively, press the TRACKING SET + or – button to stabilize the still picture.

TO WATCH A TAPE REPEATEDLY

CHECK BEFORE YOU BEGIN

- Turn ON the TV and set to the video channel 3 or 4.
- Turn ON the VCR POWER button.
- Press the TV/VCR selector button to select the VCR mode.

When a TV is connected with an audio/video cable, turn the TV and this VCR on, and select the video input mode on the TV.

- 1 Press the MENU button. Press the TRACKING SET + or – button to select the AUTO REPEAT option.

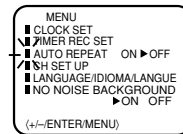

- 2 Press the ENTER button to select the ON position.

- 3 Press the MENU button. If you press the PLAY button, the tape will play over and over until the repeat mode is canceled.

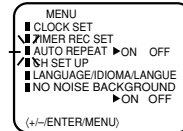

"⏮" will appear if you press the DISPLAY button. To cancel, press the DISPLAY button again.

NOTE: To cancel repeat mode, follow the above steps 1 and 2, then press the ENTER button to select the OFF position. Press the MENU button to return to the TV.

RECORDING A TV PROGRAM

RECORDING AND VIEWING THE SAME TV PROGRAM

CHECK BEFORE YOU BEGIN

- Turn ON the TV and set to the video channel 3 or 4.
- Turn ON the VCR POWER button.
- Press the TV/VCR selector button to select the VCR mode.

When a TV is connected with an audio/video cable, turn the TV and this VCR on and select the video input mode on the TV.

- 1 Load a cassette tape with the erase prevention tab intact. The VCR will automatically turn on.
- 2 Press the SP/SLP button to select the desired tape speed SP or SLP. The counter and SP or SLP will appear on the screen for about 4 seconds.

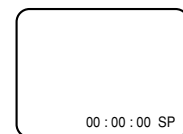



RECORDING A TV PROGRAM

VHF/UHF/CATV CHANNELS

TV	CATV
VHF 2-13	VHF 2-13
UHF 14-69	STD/HRC/IRC 14-36 (A) (W) 37-59 (AA) (WW) 60-85 (AAA) (ZZZ) 86-94 (86) (94) 95-99 (A-5) (A-1) 100-125 (100)(125) 01 (5A)

3 Press the direct channel selection buttons or the CHANNEL ▲ or ▼ button to select the channel to be recorded.

- 1-9 Press 0 twice and then 1-9 as required.
Example: To select 2, Press "002".
- 10-19 Press 0 first and then the remaining 2 digits in order from left to right.
Example: Press 012 for "12".
- 20-99 Press 2 digits in order.
Example: Press 22 for "22".
- 100-125 Press the 3 digits in order.
Example: Press 110 for "110".

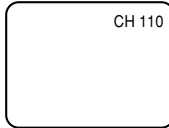

4 Press the REC button.
"●" will appear on the screen for about 4 seconds and the REC indicator will light.

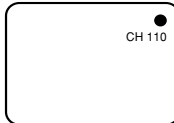

NOTE: Since the VCR has its own TV tuner, it is not actually necessary to have the TV turned on in order to make a recording. Turning on the TV merely allows confirmation of the proper channel settings on your VCR.

TO STOP RECORDING

Press the STOP button to stop recording.
"■" will appear on screen for about 4 seconds.

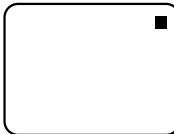

TO STOP RECORDING TEMPORARILY

Press the PAUSE/STILL button to avoid recording unwanted material. Press again or press the REC button to continue the recording.



"●||" will appear on screen for about 4 seconds and the REC indicator will blink to continue pause mode.

NOTE: The pause function will be released after 5 minutes to prevent damage to the tape or the VCR. The VCR will change to the STOP mode.

NOTE: AUTO REWIND FEATURE

This VCR will automatically rewind the tape when the tape has ended (except during OTR and TIMER REC). It will also eject the tape and turn the VCR's power OFF.

RECORDING ONE PROGRAM WHILE WATCHING ANOTHER

While the VCR is recording, press the TV/VCR selector button to select the TV position. The TV/VCR indicator will go off and recording will continue.

Select the TV channel you want to watch by using the TV channel selector.

NOTE: Some CATV hookups do not permit viewing one channel while recording another. See pages 12,13.

TO PREVENT AN ACCIDENTAL RECORDING

After recording, break off the erase prevention tab if you do not wish to record over the tape.

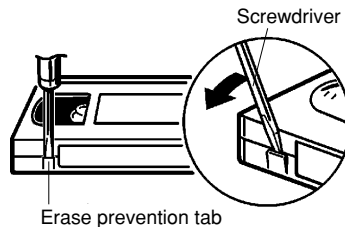

TO RECORD AGAIN

Cover the hole with adhesive tape. Be careful the tape does not extend past the edges of the cassette housing.

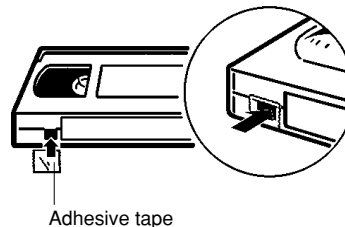



ONE-TOUCH TIMER RECORDING (OTR)

The One-touch Timer Recording feature provides a simple and convenient way to make a timed recording.

EXAMPLE: One-touch Timer Recording for 30 minutes.

CHECK BEFORE YOU BEGIN

- Turn ON the TV and set to the video channel 3 or 4.
- Turn on the VCR POWER button.

When a TV is connected with an audio/video cable, turn the TV on and select the video input mode on the TV.

- 1 Load a cassette tape with the erase prevention tab intact.
- 2 Press the SP/SLP selector button to select the desired tape speed SP or SLP.

The counter and SP or SLP will appear on the screen for about 4 seconds.

- 3 Press the direct channel selection buttons or the CHANNEL ▲ or ▼ button to select the channel to be recorded.

The channel number will appear on the screen for about 4 seconds.

- 4 Press the REC button to begin recording. Press the button again to stop recording after 30 minutes. Each additional press of the REC button will increase recording time as shown in the chart below, up to a maximum of 5 hours. The OTR and recording time will appear on screen for about 4 seconds.

- NOTES:**
- Press the REC button to increase the time needed for recording (See the chart).
 - To cancel OTR, press the STOP button or turn off the power.

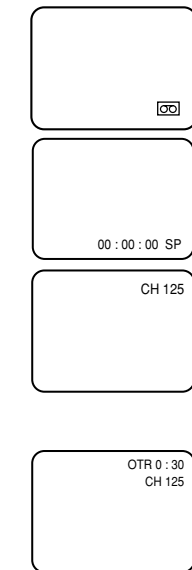

Press	Recording time
once	NORMAL REC
twice	0:30
3 times	1:00
4 times	1:30
5 times	2:00
6 times	3:00
7 times	4:00
8 times	5:00
9 times	NORMAL REC

SETTING THE TIMER RECORDING

Timer recording can be programmed on-screen with the remote control. The built-in timer allows automatic unattended recording of up to 8 programs within 1 month.

EXAMPLE: Program a timer recording for the 26th day, channel 125 (CATV), 11:00 - 11:30 PM on timer program number 1 (Tape speed: SLP).

CHECK BEFORE YOU BEGIN

- Turn on the TV and set to the video channel 3 or 4.
- Press the TV/VCR selector button to select the VCR mode.
- Load a video cassette with the erase prevention tab intact. The VCR will automatically turn on.
- Check that the clock and date are correct (see page 15).

When a TV is connected with an audio/video cable, turn the TV and this VCR on and select the video input mode on the TV.

- 1 Press the MENU button. Check the TIMER REC SET option is selected, then press the ENTER button.
- 2 Press the TRACKING SET + or - button to select one of the program line, then press the ENTER button.
- 3 Press the TRACKING SET + or - button to select the date, then press the ENTER button.
- 4 Set the start time, end time, channel and tape speed as in step 3.

NOTE: To record from external source set the channel to "L1" or "L2". "L1 (from AUDIO/VIDEO IN jacks on the rear)" or "L2 (from AUDIO/VIDEO IN jacks on the front)" will appear next to CH 125 (or 69).

- 5 To enter other programs, repeat steps 2 through 4. Or, press the MENU button twice to return to the normal screen.
- 6 Press the TIMER button. The power will go off, the T.REC indicator will light and the VCR stands by for recording.

To cancel timer recording, press the button again and the T.REC indicator will go out.

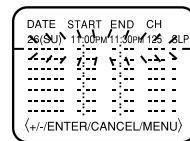
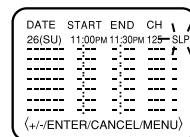
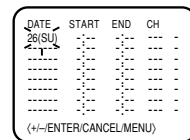
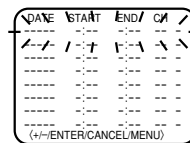
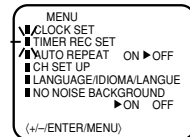



SETTING THE TIMER RECORDING

TO CORRECT THE SETTINGS

While setting, press the ENTER button to flash the item to correct, then re-enter the setting with the TRACKING SET + or - button. When finished, press the ENTER button.

- NOTES:**
- The VCR cannot be used while the T.REC indicator is lit.
 - After a power failure or disconnection of the power plug, all programmed recording settings must be reset upon resumption of power. In this case, reset the clock (see page 15) and reprogram any timer recordings.
 - Press the CANCEL button to move cursor backward for correction.

TO SET DAILY/WEEKLY TIMER

When setting the date in step 3, press the TRACKING SET - button repeatedly. The setting changes as follows:

Example

The current day (Friday) → SU-SA (Sunday to Saturday)

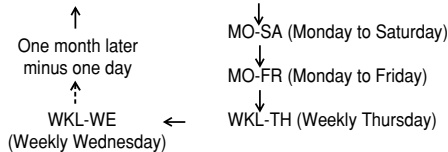

TO CONFIRM THE SETTINGS

Press the TRACKING SET + or - button to select the TIMER REC SET option in the MENU. Then press the ENTER button to display the timer program list. Press the MENU button twice to return to the normal screen.

DATE	START	END	CH
26 (WE)	11:00PM	11:30PM	125 SLP
---	---	---	---
---	---	---	---
---	---	---	---
---	---	---	---
(⇐)ENTER/CANCEL/MENU			

TO CANCEL A PROGRAM

Press the TRACKING SET + or - button to select the TIMER REC SET option in the MENU. Then press the TRACKING SET + or - button to select the unnecessary program, and press the CANCEL button to cancel the program.

DATE	START	END	CH
---	---	---	---
---	---	---	---
---	---	---	---
---	---	---	---
---	---	---	---
(⇐)ENTER/CANCEL/MENU			

IF THE PROGRAM OVERLAPS ANOTHER

NOTE: Do not overlap programs as portions of the conflicting programs will be lost. The first recording time has priority over the next recording time as shown in the diagram.

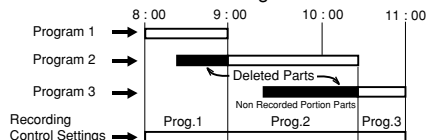

- NOTES:**
- The everyday/every week recording can be made continuously until the recording is canceled or the tape reaches the end.
 - During timer recording, the automatic rewinding mechanism does not function.

ON-SCREEN FUNCTION DISPLAY

WHILE WATCHING TV

Press the DISPLAY button.

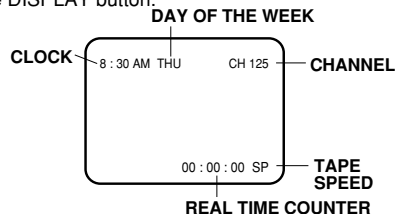

Press the DISPLAY button again to make the display disappear.

WHILE OPERATING A TAPE

Press the DISPLAY button.

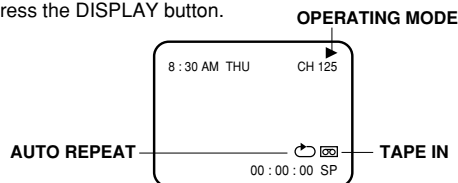

Press the DISPLAY button again to make the display disappear.

TO SET THE COUNTER TO '00:00:00'

Press the COUNTER RESET button. The counter will appear on the screen.

- NOTES:**
- If you rewind the tape from "00:00:00", a minus sign ("-") will be displayed in front of the time.
 - When you load a tape, the counter will change to "00:00:00".
 - The counter does not function on nonrecorded (blank) sections of the tape. When you rewind, fast forward or play tapes through blank sections, the counter stops.





DUPLICATING A VIDEO TAPE

If you connect the VCR to another VCR or camcorder, you can duplicate a previously recorded tape. Make all connections before turning on the power.

1 Load a blank cassette tape with the erase prevention tab intact into the recording VCR. Load a previously recorded tape into the playback VCR or CAMCORDER.

2 Press the INPUT SELECT button to select AUDIO/VIDEO input position. "LINE2" will appear on the screen.

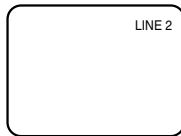

NOTE: You can also use the rear AUDIO/VIDEO IN jacks. Select "LINE1" by pressing the INPUT SELECT button.

3 Press the REC/OTR button on the recording VCR, then press the PAUSE button.

4 Press the PLAY button on the playback VCR, then press the PAUSE/STILL button.

5 Press the PAUSE/STILL button on both the VCRs simultaneously to begin the duplicating process.

NOTES:

- It is recommended that you set the SPEED to the SP mode on the recording VCR for best results.

- Unauthorized recording of copyrighted television programs, films, video tapes and other materials may infringe on the rights of copyright owners and violate copyright laws.

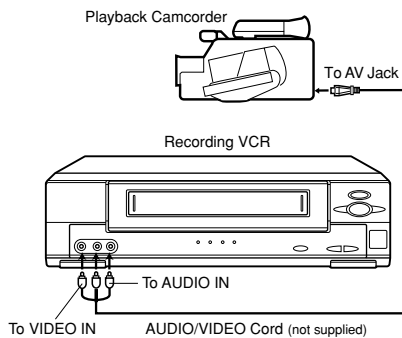
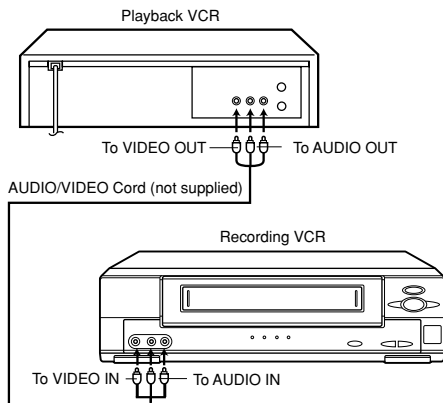

For duplicating a previously recorded tape from a camcorder, follow the camcorder manufacturer's instructions. A typical camcorder dubbing hookup is shown above.



VIDEO HEAD CLEANING

VIDEO HEAD CLOGGING

The video heads are the means by which the VCR reads pictures from the tape during playback. In the unlikely event that the heads become dirty enough to be clogged, no picture will be played back. This can easily be determined if, during playback of a known good tape, there is good sound, but no picture (picture is extremely snowy). If the heads require use a high quality head cleaning system or have them cleaned professionally.

VIDEO HEAD CLEANING

Video head cleaning is needed when the playback picture becomes unclear. This signifies that the heads are getting dirty and can occur when playing poor quality or damaged tapes. If the heads require cleaning use a high quality head cleaning system or have them cleaned professionally. If playing a head cleaning tape in the VCR once does not improve the picture, play it several times before requesting service.

DO NOT ATTEMPT TO CLEAN THE VIDEO HEADS OR SERVICE THE UNIT BY REMOVING THE TOP COVER.

- NOTES:**
- Video heads may eventually wear out and should be replaced when they fail to produce clear pictures.
 - To help prevent video head clogging, use only good quality VHS tapes. Discard worn out tapes.





BEFORE REQUESTING SERVICE

Make sure by first checking the following points.

SYMPTOM	CAUSE	POSSIBLE SOLUTION	PAGE
POWER			
No power.	The AC power cord is not connected.	Connect the AC power cord to the AC outlet.	5
Although the power is on, it does not operate.	Cassette is not inserted.	Insert a video cassette.	17
TV BROADCAST RECEPTION			
A TV program that is selected by the VCR does not appear on the screen.	Antenna connection is not correct.	Connect it correctly.	10
	Antenna cable is disconnected.	Reconnect the antenna cable.	10
	The video channel is not in the correct position.	Set it to CH 3 or 4.	15
	The TV is not set to the video channel 3 or 4.	Set the TV channel selector to the 3 or 4 position.	15
	The TV/VCR selector is set at TV mode (The TV/VCR indicator is not lit).	Press the TV/VCR selector button (The TV/VCR indicator will light).	15
	INPUT SELECT is set to the LINE mode.	Press the INPUT SELECT button to select the TV mode.	22
A TV program selected by the VCR does not appear in color.	The TV/CATV menu option setting.	Set the TV/CATV menu option to select TV or CATV mode.	22
RECORDING			
TV recording does not work.	The erase prevention tab of the video cassette is broken off.	Place a piece of vinyl tape over the gap.	19
	INPUT SELECT is set to the LINE mode.	Press the INPUT SELECT button to select the TV mode.	22
Timer recording does not work.	The time is not set correctly.	Reset the present time.	15
	The recording start/end time is not set correctly.	Set the start/end time.	20
	The TIMER button has not been pressed (The T.REC indicator is not lit).	Press the TIMER button (The T.REC indicator will light).	20
PLAYBACK			
No picture on screen when playing back a recorded tape.	The TV is not set to the video channel 3 or 4.	Set to the video channel 3 or 4 or adjust the fine tuning button on your TV set.	15
Noise bars on screen.	Tracking adjustment beyond range of automatic tracking circuit.	Adjust tracking manually using the DIGITAL TRACKING button or the TRACKING SET + or - buttons on remote control.	21
	Video heads are dirty.	Have the video heads cleaned.	22
	The tape is worn or damaged.	Try another tape.	-





SYMPTOM	CAUSE	POSSIBLE SOLUTION	PAGE
REMOTE CONTROL			
Remote control does not work.	It is not aimed at the remote sensor.	Aim it at the remote sensor.	6
	Distance too far or too much light in the room.	Operate within 15 feet (5 meters) reduce the light in the room.	6
	There is an obstacle in the path of the beam.	Clear the path of the beam.	6
	The batteries are weak.	Replace the batteries.	6
	The +, - polarity of the batteries are not inserted correctly.	Insert correctly.	6
TV programs cannot be seen using the TV selector.	The TV/VCR function is in the VCR mode.	Set to TV, or turn off the VCR power button.	-

SPECIFICATIONS

Video Head: 4 Rotary Heads
 Audio Track: MONO Sound - 1 Track
 Power Source: 120V, 60Hz
 Power Consumption: Approx. 8 watts
 Tuner: 181 Channel Freq. Synthesized
 VHF 2-13
 UHF 14-69
 CATV 14-36 (A)-(W)
 37-59 (AA)-(WW)
 60-85 (AAA)-(ZZZ)
 86-94 (86)-(94)
 95-99 (A-5)-(A-1)
 100-125 (100)-(125)
 01 (5A)
 RF Channel Output: Channel 3 or 4, Switchable
 Inputs/Outputs:
 Video: In (RCA) 1Vp-p/75 ohm
 Out (RCA) 1Vp-p/75 ohm
 Audio: In (RCA)-8dB/50K ohm
 Out (RCA)-8dB/1K ohm
 Antenna: UHF/VHF IN 75 ohm coaxial
 UHF/VHF OUT 75 ohm coaxial

F.FWD/REW Time: F. FWD: Approx. 4minutes and 50 seconds
 REW: Approx. 2minutes and 30 seconds
 (with T-120 Cassette Tape)
 Speed Search: SP - 3 & 5 X Normal Speed
 LP - 7 & 9 X Normal Speed
 SLP - 9 & 15 X Normal Speed
 Dimensions: Width: 14-3/16 inches (360mm)
 Height: 3-7/8 inches (95mm)
 Depth: 9 inches (229mm)
 Weight: 7.1 lbs
 Remote Control: Infrared, Direct Access,
 2 x AAA batteries
 Supplied accessories: Remote Control
 Batteries (2 X AAA)
 75 ohm Coaxial Cable

Specifications are subject to change without notice.
 Tape Speed shown is approximate.





LIMITED WARRANTY TOSHIBA VIDEO CASSETTE RECORDER

Toshiba America Consumer Products, Inc. ("TACP") and Toshiba Hawaii Inc. ("THI") make the following limited warranties. These limited warranties extend to the original consumer purchaser or any person receiving this VCR as a gift from the original consumer purchaser and to no other purchaser or transferee .

Limited Ninety (90) Day Warranty

TACP and THI warrant this product and its parts against defects in materials or workmanship for a period of ninety (90) days after the date of original retail purchase. During this period, TACP and THI will repair a defective product or part, without charge to you. You must deliver the entire VCR to an Authorized TACP/THI Service Station. You pay for all transportation and insurance charges for the VCR to and from the Service Station.

Limited One (1) Year Warranty

TACP/THI further warrant the parts in this product against defects in materials or workmanship for a period of one year after the date of original retail purchase. During this period TACP/THI will replace a defective part without charge to you, except that if a defective part is replaced after ninety (90) days from the date of original retail purchase you pay labor charges involved in the replacement. You must also deliver the entire product to a TACP/THI Authorized Service Station. You are responsible for all transportation for the VCR to and from the Service Station.

Rental Units

The warranty for rental units begins with the first rental or thirty (30) days from the date of shipment to the rental firm, whichever comes first.

Commercial Units

Products sold and used for commercial use have a limited ninety (90) day warranty for all parts and labor.

Owner's Manual and Demographic Card

You should read this owner's manual thoroughly before operating this product. You should complete and mail the enclosed Demographic card within ten days after you, or the person who has given you this product as a gift, purchased this product. This is one way to enable TACP/THI to provide you with better customer service and improved products. Failure to return the Demographic card will not affect your rights under this warranty.

Your Responsibility

The above warranties are subject to the following conditions:

- (1) You must retain your bill of sale or provide other proof of purchase.
- (2) You must notify an Authorized TACP/THI Service Station within thirty (30) days after you discover a defective product or part.
- (3) All warranty servicing of this product must be made by an Authorized TACP/THI Service Station.
- (4) These warranties are effective only if the product is purchased and operated in the U.S.A. or Puerto Rico.
- (5) Labor service charges for set installation, set up, adjustment of customer controls and installation or repair of antenna systems are not covered by this warranty. Reception problems caused by inadequate antenna systems are your responsibility.
- (6) Warranties extend only to defects in materials or workmanship as limited above and do not extend to any product or parts which have been lost or discarded by you or to damage to products or parts caused by misuse, accident, damage caused by Acts of God, such as lightning or fluctuations in electric power, improper installation, improper maintenance or use in violation of instructions furnished by us; or to units which have been altered or modified without authorization of TACP/THI.
- (7) At your option, after the warranty period has expired in the U.S.A. Call (800)-631-3811 to receive information concerning an exchange price. Payment must be enclosed with the product in the form of a certified check or money order and forward your product to:
Toshiba America Consumer Products Inc.
Returns Center
1420C Toshiba Dr.
Lebanon, TN 37087.
- (8) Upon receipt we will, at our option, replace your unit with a new or refurbished unit of equal value. Features may not be identical to your original product.
- (9) Physically damaged units are not acceptable for repair or exchange in or out of warranty and will be returned as received.

26





How to Obtain Warranty Service

If after following all of the operating instructions in this manual and checking the section "BEFORE REQUESTING SERVICE" and you still find that service is needed;

- (1) In the U.S.A. call the TACP toll free number 1-800-631-3811 after you find a defective product or part to find the nearest Toshiba Authorized Service Station.
- (2) Arrange for the delivery of the product to the Authorized TACP/THI Service Station. Products shipped to the Authorized Service Station must be insured and safely and securely packed, preferably in the original carton, and a letter explaining the problem must be enclosed. You are responsible for all transportation and insurance charges to and from the Authorized Service Station.

In the Continental United States call:



In Hawaii Contact

Toshiba Hawaii,
327 Kamakee Street,
Honolulu, HI 96814
(808) 591-8377

All warranties implied by state law, including the implied warranties of merchantability and fitness for a particular purpose, are expressly limited to the duration of the limited warranties set forth above. With the exception of any warranties implied by state law as hereby limited, the foregoing warranty is exclusive and in lieu of all other warranties, guarantees, agreements and similar obligations of manufacturer or seller with respect to the repair or replacement of any parts. In no event shall TACP or THI be liable for consequential or incidental damages. No person, agent, distributor, dealer or company is authorized to change, modify or extend the terms of these warranties in any manner whatsoever. The time within which action must be commenced to enforce any obligation of TACP or THI arising under this warranty or under any statute, or law of the United States or any state thereof, is here by limited to 90 days from the date you discover or should have discovered, the defect. This limitation does not apply to implied warranties arising under state law. This warranty gives you specific legal rights and you may also have other rights which may vary from state to state. Some states do not allow limitation on how long an implied warranty lasts, when an action may be brought, or the exclusion or limitation of incidental or consequential damages, so the above provisions may not apply to you.

ATTENTION CANADIAN CONSUMERS:

Canadian consumers are requested to complete the special Canadian "Warranty Registration Form" enclosed, and forward this completed form with a copy of bill of sale to TOSHIBA OF CANADA to "Register and Validate" their warranty. Products must be purchased from an Authorized Canadian Dealer. Products purchased in the U.S.A. and used in Canada are not covered by these warranties. Products purchased in Canada and used in the U.S.A. are not covered by these warranties.



TOSHIBA

TOSHIBA AMERICA CONSUMER PRODUCTS, INC.

4F11701A 
01/11

Printed in Thailand

