

# Supereasy

(AT41)

## INSTALLATION MANUAL

www.octotelematics.com



### PRODUCT REMOVAL

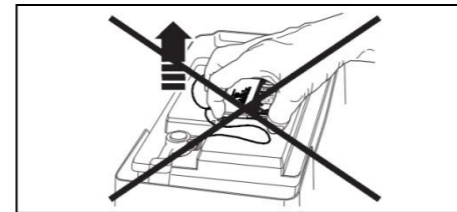

(\*)

(\*)

“Octo Telematics Spa, via Vincenzo Lamaro 51 - 00173 Roma, declares that this Telematic device is compliant to the European law 2014/53/UE, FCC, EAC<sup>(\*)</sup> ANATEL<sup>(\*)</sup>. The complete text of the declaration for conformities can be accessed to the following URL: [www.octotelematics.com/certifications](http://www.octotelematics.com/certifications).”

The information contained in this manual is merely indicative, and may be subject to modification without notice.

### Specifications

Power supply: 12 Vdc  
Working temperature: from -30°C to +80°C  
Protection level: IP 65  
Application classification: engine compartment

### Instructions for installation

#### Installation options

You can install Supereasy yourself; or you can rely on the help of Octo experts selected by the Insurance Company.

#### Installation by Octo

Call Octo/Insurance Company and ask them to find your nearest authorised installer.

- Contact your installer and make appointment.  
Take your vehicle and the product you have received to the garage of your choice on the appointed day.  
The installer will install your product for you.

#### Self installation

If the Insurance Company agent or your installer has not associated the product with your service contract, please access the Website area reserved for you and enter the IMEI code on the package or on the product into the Association Terminal menu. If you do not complete this procedure, your product will not be activated.

#### Important information

- Before installing the device, associate the device to the contract if not yet performed.
- Before carrying out any assembly operation the engine must be turned off and allowed to cool.
- Position the vehicle in the open air in a place where the geolocation satellite signals can be received properly.
- The Supereasy guarantee seal must never be removed and the product must never be opened.
- Any modifications or changes to the Supereasy are prohibited.
- The manufacturer declines all liability for damage to persons or property deriving from improper installation of the device.
- In case of doubts or problems installation, please contact Octo.

#### Tools required (not supplied)

##### Wrench for nuts

Used to loosen and tighten the nuts battery terminals.  
The size will vary according to the type of vehicle.

##### Spatula

Used to remove the product.

**The various phases of the installation process are illustrated in the pictures provided**

#### PHASE 1

Identify the position of the vehicle's battery (this may vary according to the type of vehicle) on which the Supereasy is to be fitted. The location of the battery is generally indicated in the user manual provided by the vehicle manufacturer.  
*Important: should it not be possible to install the product on the battery due to insufficient space or because of high levels of vibration, select an equivalent position integral with the vehicle's chassis.*

#### PHASE 2

Remove the battery casing (if there is one) and thoroughly clean the surface to which the Supereasy is to be fixed using the wipe provided.  
*Important: do not use the wipe to clean your face and hands. The product is highly flammable and irritating for the eyes.*

#### PHASE 3

Remove the protective film from the adhesive under the product and fix the Supereasy to the battery, making sure it is in a horizontal position. *Important: the arrow on the product must point forward, in the direction that the vehicle will be moving.*

#### PHASE 4

Connecting up. Connect the cable terminal with the black end to the negative pole (-) of the battery and the one with the red end to the positive pole (+) of the battery.

The nuts must only be loosened enough to allow the terminals to be fixed in place: do not remove the battery terminals.  
If the product LED indicator lights up, installation has been completed correctly.

*Important: when loosening the battery terminal nuts with the wrench, take care not to create an electric contact between the poles of the battery itself.*

#### PHASE 5

Shortly after the Supereasy has been connected to the vehicle's battery you will

receive a text message confirming that installation has been completed.  
*Important: if you don't receive your welcome SMS to Octo services, check if the Supereasy LED warning light is working correctly and make sure you have associated the product correctly with your service contract, as explained at the beginning of the section "Self installation".*

#### Maintenance mode

In the event of maintenance on the vehicle that requires removal of the battery or removal of Supereasy, to avoid registration of unnecessary data, such as indications of battery tampering or crashes caused by improper handling, the customer is asked to contact Octo so that the device can be set to maintenance mode. Once the work has been completed and the product has been properly re-connected to the vehicle's battery it will become operational again, as soon as the vehicle starts to move.

#### Removal of the product

Insert a flat tool between the Supereasy and the battery to detach the adhesive.  
*Important: never pull the product off by hand.*

To install the product again, use the double-sided adhesive provided, after cleaning the surface thoroughly with isopropyl alcohol.

**WARNING:** the device is protected (IP65) by accidental entry of dust, extraneous bodies and low-pressure water spurts. DO NOT install the device in vehicle's zones exposed to atmospheric agents, DO NOT expose the device to high pressure water jets (car wash, water nozzles etc.). Protect the device adequately before exposing the vehicle to high pressure water jets or in case the use of the vehicle should exceeded normal conditions.

#### STEP 1

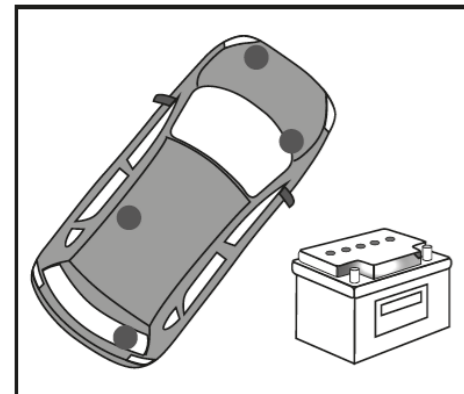

#### STEP 2

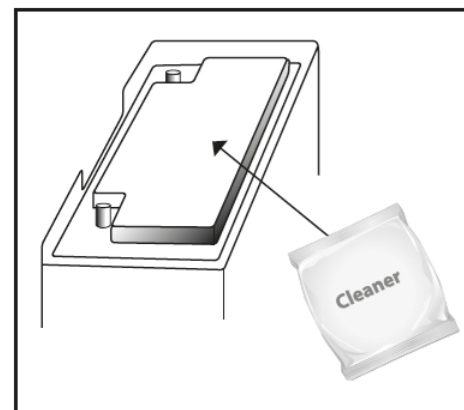

#### STEP 3

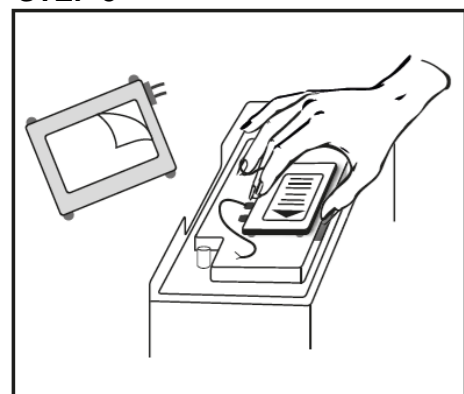

#### STEP 4

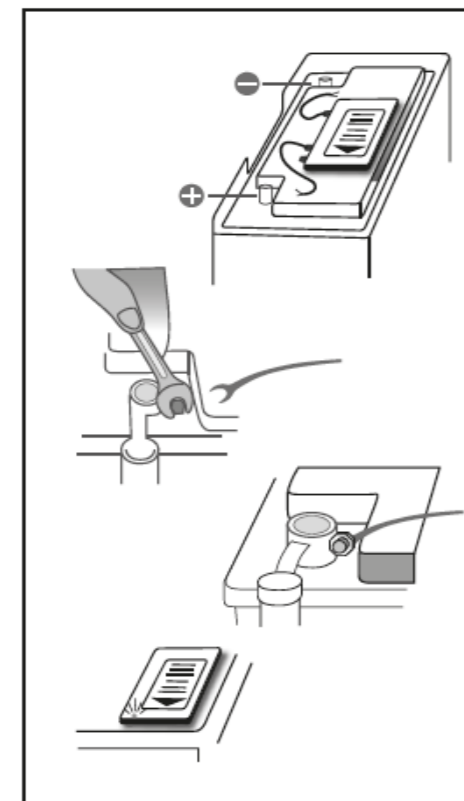

#### STEP 5

