

# Microline 8480FB

## User's Guide



59380401

## Copyright Information

---

Copyright © 2006 by Oki Data. All Rights Reserved

## Document Information

---

Microline 8480FB User's Guide  
P/N 59380401, Revision 1.1  
September, 2006

## Disclaimer

---

Every effort has been made to ensure that the information in this document is complete, accurate, and up-to-date. The manufacturer assumes no responsibility for the results of errors beyond its control. The manufacturer also cannot guarantee that changes in software and equipment made by other manufacturers and referred to in this guide will not affect the applicability of the information in it. Mention of software products manufactured by other companies does not necessarily constitute endorsement by the manufacturer .

While all reasonable efforts have been made to make this document as accurate and helpful as possible, we make no warranty of any kind, expressed or implied, as to the accuracy or completeness of the information contained herein.

The most up-to-date drivers and manuals are available from the web site:

<http://www.okiprintingsolutions.com>

## Trademark Information

---

Oki and Microline are registered trademarks of Oki Electric Industry Company Ltd. Apple, Macintosh and Mac OS are registered trademarks of Apple Computers Inc. ENERGY STAR is a trademark of the United States Environmental Protection Agency.

Hewlett-Packard, HP, and LaserJet are registered trademarks of Hewlett-Packard Company.

Microsoft, MS-DOS and Windows are either registered trademarks or trademarks of Microsoft Corporation in the United States and/or other countries.

Other product names and brand names are registered trademarks or trademarks of their proprietors.

## Regulatory Information

---



As an ENERGY STAR® Program Participant, the manufacturer has determined that this product meets the ENERGY STAR guidelines for energy efficiency.



This product complies with the requirements of the Council Directives 89/336/EEC (EMC), 73/23/EEC (LVD) and 1999/5/EC (R&TTE), as amended where applicable, on the approximation of the laws of the member states relating to Electromagnetic Compatibility, Low Voltage and Radio & Telecommunications Terminal Equipment.

# Contents

<b>Copyright Information</b> . . . . .	<b>2</b>
Document Information. . . . .	2
Disclaimer . . . . .	2
Trademark Information . . . . .	2
Regulatory Information . . . . .	2
<b>Introduction</b> . . . . .	<b>5</b>
Features . . . . .	5
Front View, Outside . . . . .	6
Front View, Inside (1) . . . . .	7
Front View, Inside (2) . . . . .	7
Rear View . . . . .	8
<b>Control Panel</b> . . . . .	<b>9</b>
Quick Reference: Control Panel Functions . . . . .	14
<b>Print Modes</b> . . . . .	<b>15</b>
Normal Print Mode . . . . .	15
High Speed Print Mode . . . . .	15
High Impact Print Mode . . . . .	15
Change Print Mode . . . . .	16
<b>Loading Print Media</b> . . . . .	<b>17</b>
Individual Sheets/Forms (“MANUAL”) . . . . .	17
Continuous Forms (“FRONT”) . . . . .	19
Switching Between Normal and High Impact Mode . . . . .	22
Switch between Single Sheets and Continuous Forms . . . . .	23
<b>Function Setting Menu</b> . . . . .	<b>24</b>
Print the Menu . . . . .	24
Navigating the Menu . . . . .	25
Reset to Factory Defaults . . . . .	28
Print the Menu . . . . .	29
Menu Summary . . . . .	32
Explanation of Menu Items. . . . .	40
<b>Auto Align</b> . . . . .	<b>54</b>
Disabling Auto Align . . . . .	54

- Set Top of Form (TOF) . . . . . 56**
  - General Information . . . . . 56
  - Use the Printer Menu . . . . . 56
  - Use 1Chr Set Pos . . . . . 58
  - Temporary TOF. . . . . 60
- Form Tear Off . . . . . 61**
  - Turn On Forms Tear Off. . . . . 61
  - Move Continuous Forms Up for Tear Off. . . . . 62
- Tests . . . . . 63**
  - Rolling ASCII Test . . . . . 63
  - Font Sample Test . . . . . 63
  - Hex Dump Mode . . . . . 64
- Setting the Printhead Gap. . . . . 65**
  - General Information . . . . . 65
  - Printhead Gap Settings . . . . . 66
  - Change to a Manual Printhead Gap Setting . . . . . 67
- Troubleshooting . . . . . 69**
  - Paper Jams: Single Sheet . . . . . 69
  - Paper Jams: Continuous Forms. . . . . 70
  - Paper Jams: Correcting Repetitive Jams . . . . . 71
  - Error Messages. . . . . 74
- Maintenance . . . . . 76**
  - Replace the Ribbon . . . . . 76
  - Clean the Housing. . . . . 81
- Control Codes . . . . . 83**
  - In Sequence by ASCII Code . . . . . 83
  - In Sequence by Function . . . . . 90
- Specifications . . . . . 97**

# Introduction

## Features

- Precise registration control for printing complicated forms
- Flexible handling of multi-part forms
  - Individual or continuous feed
  - Maximum = original + 7
  - Up to 0.02-inch (0.48 mm) thick
- Automatic alignment when feeding individual forms/sheets.
- Fast through-put
- Reliable, durable operation
- Automatic adjustment for paper thickness
- Paper Park
- Form Tear Off
- Choice of Print Modes: Normal, High Speed (for printing drafts), or High Impact (for use with thick multi-part forms)

# Front View, Outside

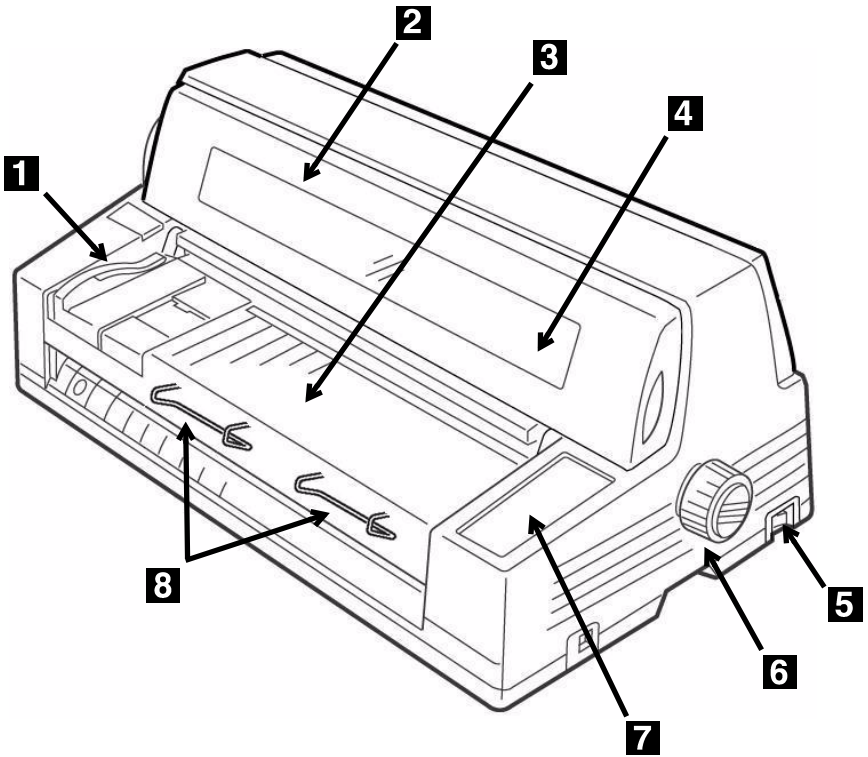

- 1** Sheet Guide
- 2** Cover
- 3** Platform for Manual Feed
- 4** Display Panel
- 5** On/Off Switch
- 6** Platen Knob
- 7** Control Panel
- 8** Sheet Supports

## Front View, Inside (1)

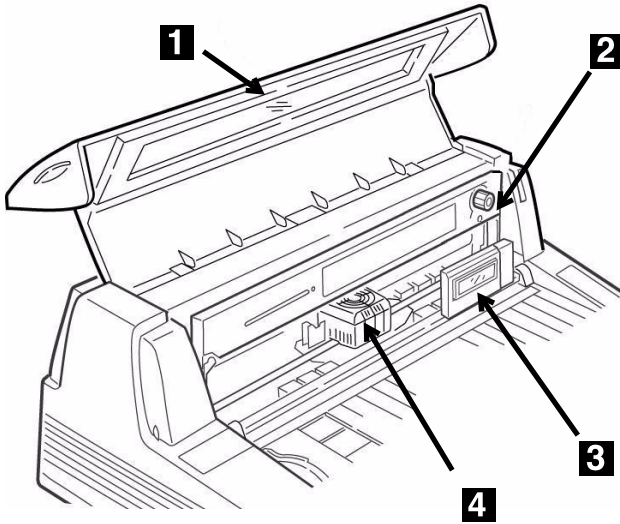

- 1 Cover
- 2 Ribbon Cartridge
- 3 LCD Display Panel
- 4 Printhead

## Front View, Inside (2)

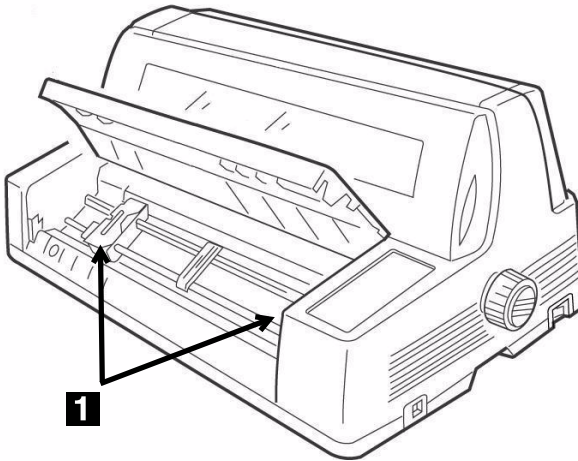

- 1 Tractors

# Rear View

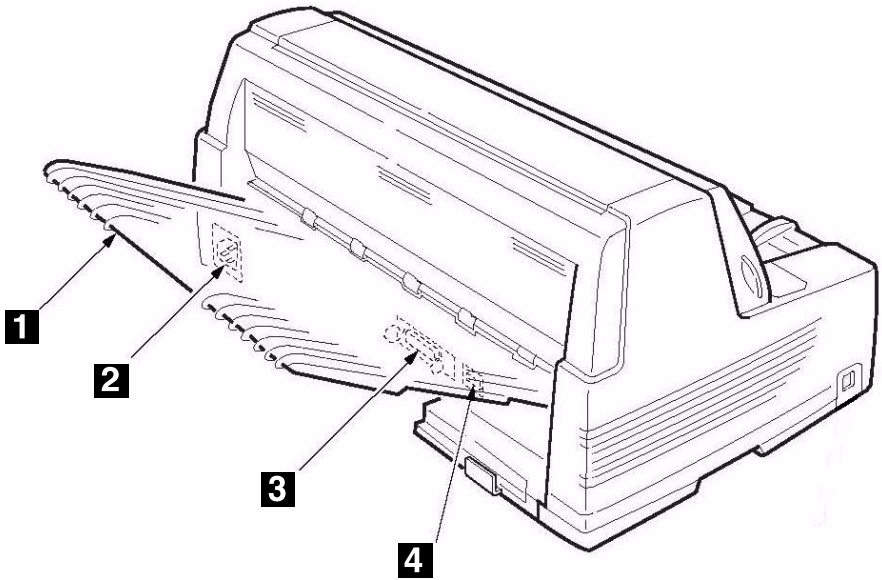



- **1** Stacker
- **2** Power Cord Connector
- **3** Parallel Port
- **4** USB Port







# Control Panel



## Individual Switches





Switch	Printer On Line	Printer Off Line (Deselected)
	Press to place the printer off line.	Press to place the printer on line. <i>Function Setting Menu Mode</i> <ul style="list-style-type: none"> <li>• Scrolls backwards through available settings for an item.</li> </ul>
	Engages the High Impact print mode.	Used to switch back and forth between Manual Feed (single forms fed from the platform) and Front Feed (continuous forms). See page 23. <i>Function Setting Menu Mode</i> <ul style="list-style-type: none"> <li>• Scrolls forward through available settings for an item.</li> </ul>

# Individual Switches

Switch	Printer On Line	Printer Off Line (Deselected)
	Engages the High Speed Print mode.	<p><i>Continuous Forms</i></p> <ul style="list-style-type: none"> <li>In the print position: form feeds to next TOF position.</li> <li>Loaded on the tractors, but not in the print position: the paper advances to the print position.</li> </ul> <p><i>Single Forms</i></p> <ul style="list-style-type: none"> <li>If a form is loaded into the printer, it is ejected.</li> </ul> <p><i>Function Setting Menu Mode</i></p> <ul style="list-style-type: none"> <li>Scrolls forward through available items within a group.</li> </ul>
	Engages the Normal Print mode.	Advances forms one line at a time. Press and hold for repetitive line feeds. <p><i>Function Setting Menu Mode</i></p> <ul style="list-style-type: none"> <li>Scrolls backward through available items within a group.</li> </ul>
	Toggles the eject direction for single sheets between the front and back of the printer.	<p><i>Continuous Forms</i></p> <ul style="list-style-type: none"> <li>In the print position: parks the paper (moves it out of the print path, back to the tractors).</li> <li>Loaded on the tractors, but not in the print position: the paper advances to the print position.</li> </ul> <p><i>Single Forms</i></p> <ul style="list-style-type: none"> <li>If a form is loaded into the printer, it is ejected.</li> </ul> <p><i>Function Setting Menu Mode</i></p> <ul style="list-style-type: none"> <li>Saves any changes made in the menu and exits the Menu Mode, placing the printer back on line.</li> </ul>
	Moves continuous forms forward to the tear position.	Used with other switches to change their function (see table below).

# Combined Switches

## With the Printer Powered Up and Off Line

Switches	Task Performed
	<p><b>Select Align 1, Align 2, Align 3, or Align 4:</b>            Press and hold the MODE switch, <i>then press the SHIFT switch</i> repeatedly to select Align 1, Align 2, Align 3, or Align 4 as the setting for Auto Align (see page 41).</p> <ul style="list-style-type: none"> <li>• Auto Align (POW) [see page 42] must be set to SelectAutoALIGN (the default).</li> <li>• The setting made using these switches is stored in Memory Auto Align (see page 47) unless it has been changed to Invalid.</li> </ul> <p><b>Enter the Function Setting Menu:</b>            Press <i>both</i> the MODE and the SHIFT switches <i>simultaneously</i> to place the printer in the Function Settings Menu mode.</p>
	<p>Simultaneously press and hold the SHIFT and SEL switches to move continuous forms up to the tear off position (see page 61).</p> <p><b>Note:</b> <i>Form Tear Off must be engaged. The factory default is Off.</i></p>
	<p>Press and hold SHIFT, then press FF repeatedly to move loaded paper (single sheets or continuous forms) forward 1/180-inch at a time.</p> <p>If you press and hold SHIFT, then press and hold LF, the paper will advance in rapid-fire 1/180-inch increments.</p>
	<p>Press and hold SHIFT, then press LF repeatedly to move loaded paper (single sheets or continuous forms) backward 1/180-inch at a time. Maximum allowed backward movement is 1/3-inch (8.5 mm).</p> <p>If you press and hold SHIFT, then press and hold LF, the paper will advance backward in rapid-fire 1/180-inch increments.</p>

## Combined Switches

### With the Printer Powered Up and Off Line

Switches	Task Performed
	<p>Press and hold both the LOAD and the SHIFT switches to change the printhead gap setting. The factory default is Auto Gap in which the required printhead gap is sensed automatically by the printer. Use these switches to change the setting to a manual head gap setting if you are not getting good print results with AutoGap. See "Gap Control" on page 44 for more information.</p>

## Control Panel Lights

Light	On	Off	Blinking <sup>a</sup>
POWER	Printer is turned on.	Printer is turned off.	N.A.
AUTO GAP	Auto Gap mode is selected (the default).	A Manual Gap setting is engaged.	Manual Gap setting alarm.
ALARM	<ul style="list-style-type: none"> <li>• Paper is out.</li> <li>• A paper jam has occurred.</li> </ul> <p>See "Troubleshooting" on page 69 for more information</p>	Printer operation is normal.	<ul style="list-style-type: none"> <li>• Awaiting removal of single sheet/form.</li> <li>• Media switch is taking place.</li> <li>• If both the ALARM and SEL lights are blinking, the cover is open.</li> <li>• If both the ALARM and AUTO ALIGN lights are blinking, there is an unrecoverable error. Try turning the printer off, then on again. IF this doesn't clear the problem call your service dealer</li> </ul>

## Control Panel Lights

Light	On	Off	Blinking <sup>a</sup>
AUTO ALIGN	The printer is set to automatically align single sheets/ forms.	Auto Align is disabled	If both AUTO ALIGN and ALARM are blinking, it indicates an unrecoverable error. Try shutting the printer off and turning it on again. If this doesn't work, call your service dealer.
HIGH SPEED	The printer is in the High Speed (draft) print mode.	The printer is not in the High Speed (draft) print mode.	N.A.
HIGH IMPACT	The printer is in the High Impact print mode.	The printer is not in the High Impact mode.	N.A.
SEL	The printer is on line.	The printer is off line.	<ul style="list-style-type: none"> <li>• Menu Mode: indicates the menu is being set up.</li> <li>• With ALARM light: cover open alarm.</li> </ul>
EJECT DIRECTION	Paper is being ejected to the platform.	Paper is being ejected to the stacker.	N.A.

a. N.A. = Not Applicable.

# Quick Reference: Control Panel Functions

**Note** *Unless otherwise specified, these instructions assume that the printer is selected (on line).*

## Enter the Menu

1. Press SEL.
2. Press both the MODE and the SHIFT switches simultaneously.

## Print the Menu

1. With the printer in the Manual Mode, turn it off.
2. Press and hold SELECT and MODE while turning the printer on.
3. When prompted, load a sheet of paper (minimum letter or A4) on the platform.

## Change Print Modes

With the printer on line:

1. Press LF to engage the Normal Print Mode.
2. Press MODE to engage the High Impact Print Mode.
3. Press FF to engage the High Speed (Draft) Print Mode.

## Change the Printhead Gap

1. Press SEL.
2. Press and hold the SHIFT switch, then press the LOAD switch repeatedly to scroll through the various settings for the printhead gap.
3. Press SEL

## Change Paper Paths

1. Press SEL.
2. Press MODE repeatedly to change the paper path.

*The printer automatically reinitializes in the new path.*

## Move Continuous Forms to the Print Position

1. Press SEL.
2. Press FF.

## Park Continuous Forms

1. Press SEL.
2. Press LOAD.

## Move Continuous Forms to the Tear Off Position

**Note** *Form Tear Off must be activated (see page 61).*

1. Press SEL.
2. Press and hold the SHIFT and SEL switches to move continuous forms up to the tear off position.

## Change Align x Setting

1. Press SEL.
2. Press and hold the MODE switch, then press the SHIFT switch repeatedly to select Align 1, Align 2, Align 3, or Align 4

# Print Modes

Your printer has three print modes:

- **Normal:** for letter-quality printing
- **High Speed:** for printing drafts
- **High Impact:** for printing multipart forms

## Normal Print Mode

Use for every day, letter-quality printing.

## High Speed Print Mode

Use for high speed draft printing.

When this mode is selected, the print appears lighter than in the Normal print mode.

## High Impact Print Mode

In High Impact print mode, each character is printed twice.

This mode is used to print thick multi-part forms or multipart forms with a thick first page and thin second (or more) pages.

### **Caution!**

**High Impact print mode can cause the paper to tear:**

- if the paper is too thin
- if you print horizontal lines

**High Impact Print Mode reduces ribbon life expectancy.**

- If you consistently use High Impact Print Mode, ribbon life can be cut in half.

**If you have a new ribbon and use High Impact Print Mode to print high-density characters or graphics, the paper may be smudged.**

# Change Print Mode

## Change to Normal

**Note** *If you change the print mode while printing, the printer immediately switches to the new print mode.*

1. Make sure the printer is turned on and that the SEL light is on.
2. Press LF/Normal PRIN.



3. The HIGH SPEED or HIGH IMPACT light goes out.

## Change to High Speed

**Note** *If you change the print mode while printing, the printer immediately switches to the new print mode.*

1. Make sure the printer is turned on and that the SEL light is on.
2. Press FF/High Speed Print.



3. The HIGH SPEED light goes on.

## Change to High Impact

**Note** *If you change the print mode while printing, the printer immediately switches to the new print mode.*

1. Make sure the printer is turned on and that the SEL light is on.
2. Press MODE/High Impact.



*The HIGH IMPACT light goes on.*



# Loading Print Media

## Individual Sheets/Forms (“MANUAL”)

The printer is set at the factory for

- single sheets/forms
- Auto Align mode
- Normal print mode
- automatic printhead gap

## Specifications

### Individual Sheets/Forms, for Use with Auto Align Mode

**Note** *Printing envelopes requires use of the sheet guide (1) instead of the Auto Align mode. See page 54 for information on disabling Auto Align.*

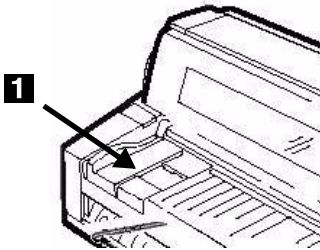

### Minimum Print Margins

- 1/4-inch (6.4 mm) on all sides

### Individual Sheets

#### Size

- Minimum Width x Length: 3.9" (100 mm) x 2.75" (70 mm)
- Maximum Width x Length: 14.3" (364 mm) x 16.5" (420 mm)

#### Weight Range

- 14 lb. to 56 lb. US Bond (52 to 210 g/m<sup>2</sup>)

## Individual Multipart Forms

### Size

- Minimum Width x Length: 3.9" (100 mm) x 2.75" (70 mm)
- Maximum Width x Length: 14.3" (364 mm) x 14.3" (364 mm)

### Normal Print Mode (the factory default)

- Up to 6-part forms (original + 5)
- Maximum Thickness: 0.0142" (0.36 mm)

### High Impact Mode

- Up to 8-part forms (original + 7)
- Maximum Thickness: 0.0189" (0.48 mm)

## Load Individual Sheets/Forms

1. If you are using longer paper, pull out the sheet supports (1).
2. Move the sheet guide (2) to the right as far as it will go. This ensures that the single sheet/form is within the "Paper range when Auto Align is ON" area on the platform.

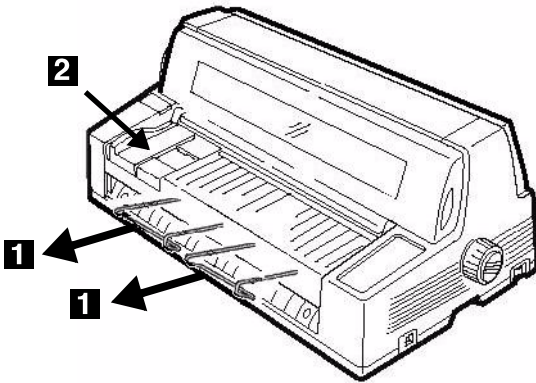

3. Place a letter size or larger sheet of paper on the platform anywhere within the "Paper range when Auto Align is ON" area.

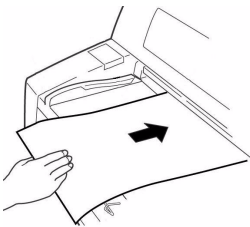

*The sheet loads in to the print position, automatically aligning so that it is square with the print path.*

# Continuous Forms ("FRONT")

## Specifications

### Width

- Minimum: 4" (102 mm)
- Maximum: 16" (406 mm)

### Single Thickness Forms

- Weight range: 14 to 34 lb. US Bond (52 to 128 g/m<sup>2</sup>)

### Multi-part Forms

*Normal Print Mode (the printer default)*

- up to 6-part forms (original + 5)
- Maximum Thickness: 0.0142" (0.36 mm)

*High Impact Mode*

- up to 8-part forms (original + 7)
- Maximum Thickness: 0.0189" (0.48 mm)

*To switch between Normal and High Impact mode, see page 22.*

## Load Continuous Forms

1. Push the sheet supports in and lift the sheet feed platform.

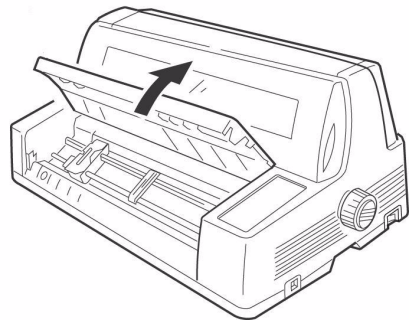
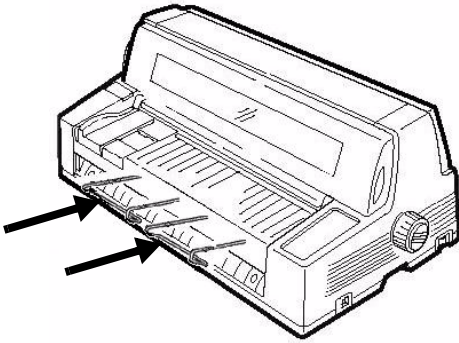

2. Lift the lock lever on the left tractor, then move the left tractor to set the desired left margin for printing.
- The ▼ mark on the gauge (1)—or the center of the diamond shaped hole (2)—represents the location of the center of the first character printed.
  - For printing forms, move the left tractor to the right as far as it will go (the movement of the left tractor is limited to ensure that the paper covers the paper out sensor).

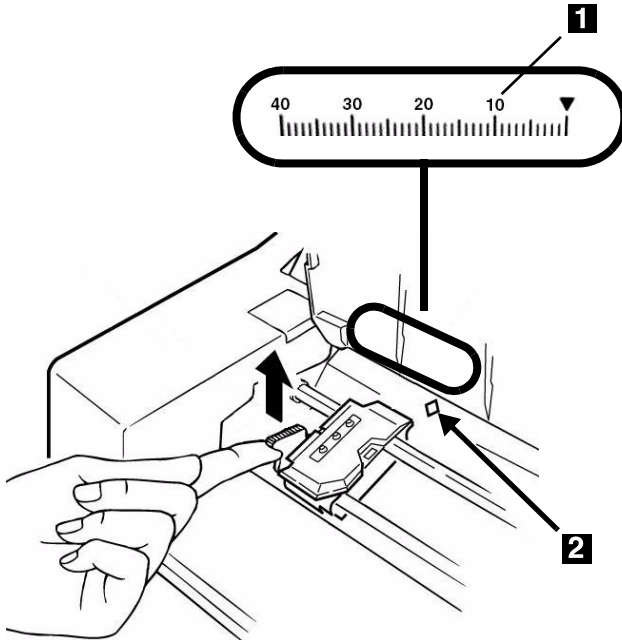

3. Push the lock lever down to lock the left tractor in place.
4. Lift the lock lever (1) on the right tractor (2) and move the tractor over to correspond to the width of the continuous forms you are using. Center the paper support (3) between the two tractors.

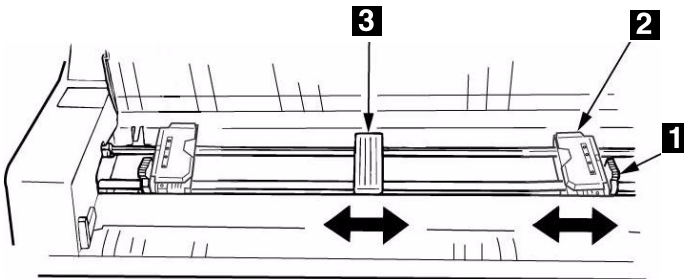

5. Open both tractor covers and place the first three holes in the continuous forms paper over the pins.

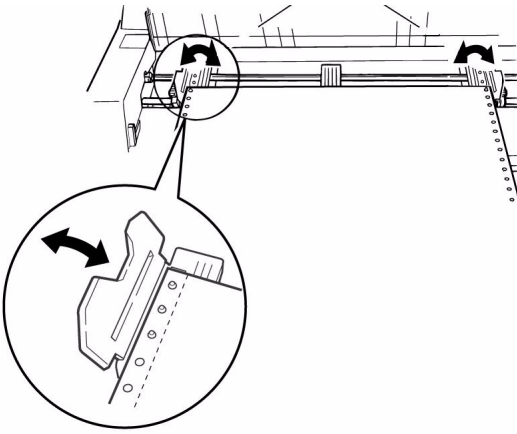

***Important!***

**Make sure that an equal number of paper holes are engaged on each tractor. If not, the paper will jam.**

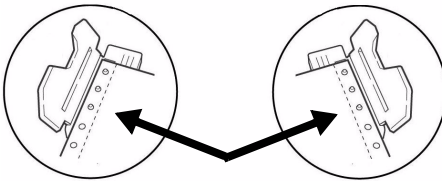

6. Close the tractor covers and fine tune the position of the right tractor until the holes in the paper are centered on the pins, then push back the right tractor lock lever.

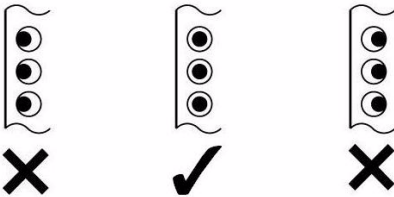

7. Lower the platform.

8. Position the continuous forms stack below the printer with no more than about 1 inch (3 cm) offset (1).

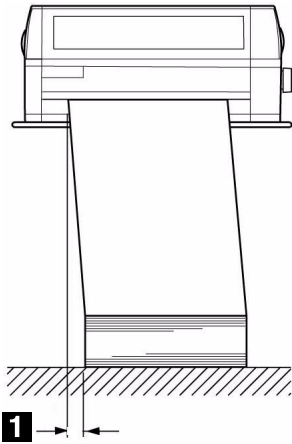

## Switching Between Normal and High Impact Mode



### Normal to High Impact Print Mode

Press MODE/HIGH IMPACT.

*The LED beside HIGH IMPACT comes on and **H-IMPCT** appears at the end of the first line of the display.*



### High Impact to Normal Print Mode

Press LF/NORMAL PRIN.

*The LED beside HIGH IMPACT goes out and **NORMAL** appears at the end of the first line of the display.*

# Switch between Single Sheets and Continuous Forms



## Single Sheets to Continuous Forms

### Manual Feed to Front Feed

1. With the printer turned on, press SEL to place the printer off line.
2. If there is a single sheet loaded into the printer, press LOAD to eject it.
3. Press MODE once or twice until you see **FRONT** on the second line of the display.  
*The printer switches paths and returns to the on-line state.*
4. If there are continuous forms in the parked position, the printer automatically pulls them into the print position.
5. If continuous forms are not loaded, the display prompts you to **INSERT PAPER**. Load continuous forms on the tractors (see page 19) and press LOAD to advance them to the print position.

## Continuous Forms to Single Sheets

### Front Feed to Manual Feed

1. Press SEL to place the printer off line.
2. Press LOAD to park the continuous forms.  
*The continuous forms retract back to the tractors.*
3. Press MODE once or twice until you see **MANUAL** on the second line of the display.  
*The printer switches paths and returns to the on-line state.*
4. Load a sheet or form on the platform.

# Function Setting Menu

Make changes in the menu settings using the front panel keys. The changes are automatically saved when you exit the Function Setting Menu and are retained, even when you turn the printer off.

**Note** *Always print the Function Setting Menu before you reset or change the settings. This is the only way to have a record of the settings.*

## Print the Menu

For more information, see "Print the Menu" on page 29.

1. Make sure the printer is in the manual mode.
2. Turn the printer off.
3. Press and hold SELECT and MODE while turning the printer on.
4. When "RELEASE SW" displays, release the switches.
5. When prompted, load a sheet of paper (minimum letter or A4) on the platform.

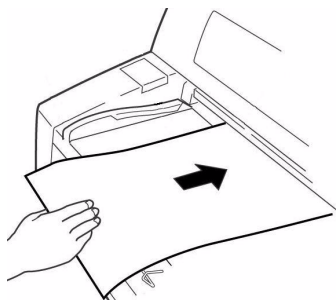

*The menu prints.*



# Navigating the Menu

## Groups, Items, and Settings

Each Group includes multiple Items, each of which has selectable Settings:

Group 1	Item 1	Setting 1 ... Setting X
	...	Setting 1 ... Setting X
	Item X	Setting 1 ... Setting X

## Access the Menu

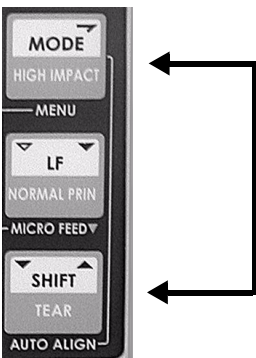

1. With the printer turned on and on line, press SEL.  
**OFFLINE** displays.
2. Simultaneously press the SHIFT and MODE switches.





**PRINTER CONTROL** displays.

# Scrolling Through Groups, Items and Settings

## Groups

Press and hold  , then press  to scroll forward.

Press and hold  , then press  to scroll backwards.

## Items

Press  to scroll forward.

Press  to scroll backwards.

## Settings

Press  to scroll forward.

Press  to scroll backwards.

## Exit the Menu

Press  .

## Example: Turn on Proportional Spacing and Form Tear-Off

1. Turn on the printer.
2. Press SEL.  
*The printer goes off-line.*
3. Simultaneously press SHIFT and MODE.

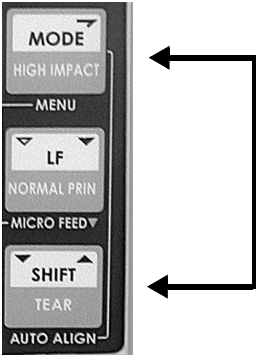

4. Press and hold SHIFT, then press FF repeatedly until **FONT** displays.

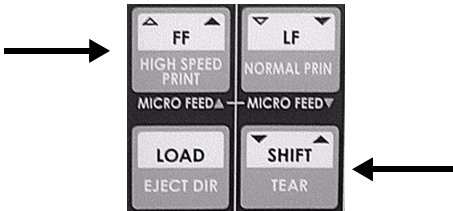

5. Press FF repeatedly until **PROP. SPACING** displays.



6. Press MODE.



*The setting changes to **YES**.*

7. Press and hold SHIFT, then press FF repeatedly until **FRONT FEED** displays.

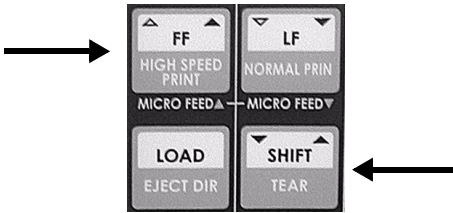

8. Press FF repeatedly until **FORM TEAR-OFF** displays.



9. Press MODE.



*The setting changes to **ON**.*

10. Press LOAD: this saves your setting and exits the menu mode.



## Reset to Factory Defaults

**Note** *Always print the Function Setting Menu (see page 29) before you reset or change the settings. Printing the Function Setting Menu is the only way to have a record of the settings.*

1. Turn the printer off.
2. Press and hold SEL and SHIFT while turning the printer on.

MENU INITIALIZE

FNC. MENU

*displays.*

# Print the Menu

**Note** Always print the Function Settings Menu before you reset or change the settings. Printing the Function Settings Menu is the only way to have a record of the settings.

## Single Sheet (Manual Feed)

### Before Starting

1. Have a sheet of letter size or larger paper ready to print the menu.
2. Slide the sheet guide (1) to the right as far as it will go.

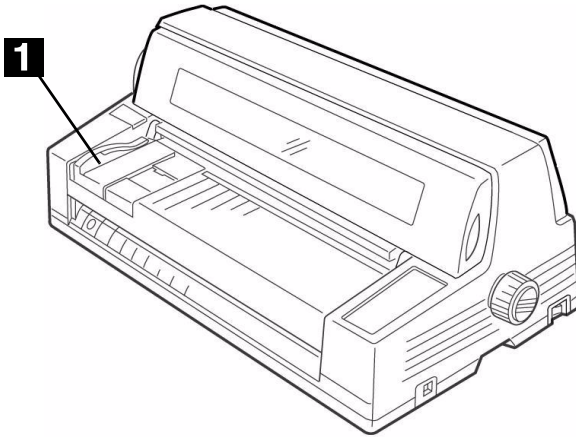

3. Make sure the Page Length (see page 35) set in the menu matches the paper you are using to print the menu.
4. Make sure manual feed is selected.

If continuous forms feed is selected, FRONT appears on the second line of the display. To switch to manual feed:

- a. Press SEL to place the printer off-line.
- b. Press MODE. The display changes to  
PATH CHANGE  
FRONT
- c. Press the MODE switch one or two times until MANUAL appears on the second line of the display.

*The printer automatically switches to the manual path and returns on line.*

## Print the Menu on Single Sheets

1. Turn the printer off.
2. Press and hold SELECT and MODE while turning the printer on.
3. When "RELEASE SW" displays, release the switches.
4. Load the paper on the platform.

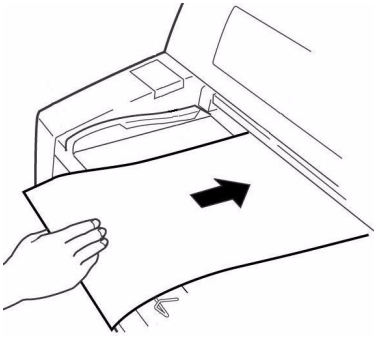

5. The menu prints.

## Continuous Forms (Front Feed)

### Before Starting

1. Make sure continuous forms are loaded.

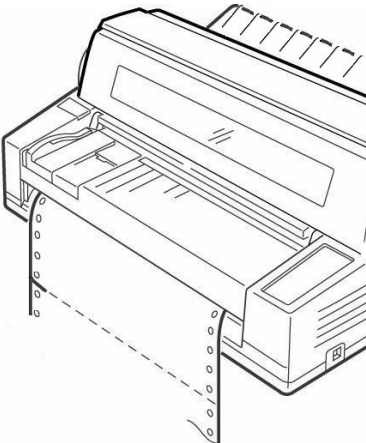

2. Make sure front feed is selected. If manual feed is selected, the second line of the display reads ALIGN1 (the default, or whatever alignment method you have selected).

To switch from manual feed to continuous forms:

- a. Press SEL to place the printer off-line.
- b. Press MODE. The display changes to  
PATH CHANGE  
MANUAL

Press the MODE switch one or two times until FRONT appears on the second line of the display.

*The printer automatically switches to the front path and returns on line.*

### **Print the Menu on Continupus Forms**

1. Turn the printer off.
2. Press and hold SELECT and MODE while turning the printer on.
3. When "RELEASE SW" displays, release the switches.

*The Function Settings menu prints.*

4. Press the SHIFT switch.

*The printed sheet advances to the stacker for tear off.*

5. Tear off the printed form.
6. Press the SHIFT switch to move the continuous forms back down to the print position.

# Menu Summary

**Note** The default setting is in **bold blue** type.

Group	Item	Settings
Printer Control	Emulation Mode	<b>Epson LQ</b> , IBM PPR, IBM AGM, Diablo
Font	Print Mode	<b>LQ Courier</b> , LQ Roman, LQ Swiss, LQ Swiss Bold, LQ Orator, LQ Gothic, LQ Prestige, Utility
	Pitch	<b>10</b> , 12, 15, 17.1, 20 cpi
	Prop. Spacing	<b>No</b> , Yes
	Style	<b>Normal</b> , Italic
	Size	<b>Single</b> , Double
	Character Set	<b>Set I</b> , Set II
	Language Set	<b>American</b> , French, German, British, Danish 1, Swedish, Italian, Spanish I, Japanese, Norwegian, Danish II, Spanish II, Latin American, French Canadian, Dutch, Publisher
	Zero Character	<b>Slashed</b> , Unslashed
	Code Page	<b>USA</b> , Canada French, Multilingual, Portugal, Norway, BRASCII, Abicomp, Multilingual 1858, ISO-8859=15,



<b>Group</b>	<b>Item</b>	<b>Settings</b>
Command Fnc.	Auto LF	<b>No</b> , Yes
	Auto CR <i>IBM Emulations Only.</i>	<b>No</b> , Yes
	Print Suppress	<b>No</b> , Yes
	FF Function	Not Used.
	Eject Condition	Not Used
	Print Dir. CMD.	<b>Valid</b> , Invalid
	SI Pitch (10) <i>IBM Emulations Only.</i>	15, <b>17.1</b> cpi
	SI Pitch (12) <i>IBM Emulations Only.</i>	12, <b>20</b> cpi
	Reset Inhibit	<b>No</b> , Yes
	ESC US Pitch <i>Diablo Emulation Only.</i>	<b>Standard</b> , Special
Set Up	Multi Pass	<b>Bi-directional</b> , Uni-directional
	Graphics	<b>Bi-directional</b> , Uni-directional
	High Skip	<b>Yes</b> , No
	Hi-Impact Copy	<b>Invalid</b> , Valid
	Quiet	<b>Invalid</b> , Valid

<b>Group</b>	<b>Item</b>	<b>Settings</b>
Hardware	Rcv. Buffer	<b>128</b> , 0 K
	Path Change	<b>Not Tear Off</b> , Tear Off
	CutSheet Smooth	<b>Valid</b> , Invalid
	Skp Ovr Binding	Invalid, <b>Valid 1</b> , Valid 2
	Sheet Feed Mode	Not used.
	CSF Select	Not used.
	Host Interface	Auto, <b>Interface</b> , Parallel, USB
	I/F Time Out Appears only if Host Interface (above) is set to Interface.	<b>15 sec</b> , 30 sec, 45 sec, 1 min, 2 min, 3 min, 4 min, 5 min
	Parallel I/F Only Nibble Mode supports bi-directional	Uni-Directional, <b>Bi-Directional</b>
	Auto Feed XT	<b>Invalid</b> , Valid
	I-Prime	<b>Enable</b> , Disable
	Buzzer	<b>Enable</b> , Disable
	Buzzer Volume	<b>Low</b> , Middle, High
	Power Saving	<b>Enable</b> , Disable
	Power Save Time	5 min, <b>10 min</b> , 15 min, 30 min, 60 min

<b>Group</b>	<b>Item</b>	<b>Settings</b>
Form Select	Line Spacing	<b>6 LPI</b> , 8 LPI
	Page Length	<b>279.4 mm (11")</b> , 304.8 mm (12")
	Skip Over Perf.	<b>No</b> , Yes
	Auto Eject Pos.	3.18 mm (1/8"), <b>6.35 mm (1/4")</b>
	Page Width	8". 10.6", 13.2", <b>13.6"</b>
	Check Print Area	<b>Valid</b> , Invalid
	ManualFeedCSF	Not Used.
	ManualSheetCSF	Not Used.

Group	Item	Settings
Manual Feed	TOF	2.12 mm (1/12"), 3.18 mm (1/8"), <b>6.35 mm (1/4")</b> , 7.62 mm (3/10"), 8.47 mm (1/3"), 10.58 mm (5/12"), 23.28 mm (11/12"), 25.4 mm (1"), 27.52 mm (13/12"), 1Chr. Set Pos. <i>Note:</i> 1Chr. Set Pos. automatically appears as the setting when the front panel has been used to set a 1Chr. Set Pos value for the Manual Feed path (see page 59).
	Wait Time <i>Auto Alignment must be disabled to use Wait Time.</i>	<b>2.0 sec</b> , 1.5 sec, 1.0 sec, 0.5 sec
	Load LF Speed	<b>Fast Speed</b> , Slow Speed
	Eject Dir.	<b>Front</b> , Rear
	Paper End	<b>On-line</b> , Off-line
	Gap Control	<b>Auto</b> , Manual Gap x x = 1 - 8, A - E (see page 67)
	Gap Pos.	<b>50.8 mm (2")</b> , 101.6 mm (4")
	Auto Align (POW)	Align 1, Align 2, Align 3, Align 4, <b>Select Align</b>
	Auto Align	<b>Align 1</b> , Align 2, Align 3, Align 4, Invalid
	MemoryAutoAlign	<b>Valid</b> , Invalid

<b>Group</b>	<b>Item</b>	<b>Settings</b>
Manual Feed (cont.)	Align1 Pos.Adj. (Align 1 must be selected)	0 mm, <b>5.1 mm</b> , 45.4 mm Adjusts in 1/90 inch (0.28 mm) increments from initial setting
	Align2 Pos.Adj. (Align 2 must be selected)	0 mm, <b>5.1 mm</b> , 45.4 mm Adjusts in 1/90 inch (0.28 mm) increments from initial setting
	Align3 Pos.Adj. (Align 3 must be selected)	0 mm, <b>5.1 mm</b> , 45.4 mm Adjusts in 1/90 inch (0.28 mm) increments from initial setting
	Align4 Pos.Adj. (Align 4 must be selected)	0 mm, <b>5.1 mm</b> , 45.4 mm Adjusts in 1/90 inch (0.28 mm) increments from initial setting
	AutoAlignDetect	Valid Level 1, <b>Valid Level 2</b> , Invalid
	Skew Detect	Valid Level 1, <b>Valid Level 2</b> , Invalid
	Set Alarm	<b>Valid</b> , Invalid
CSF Front	Not Used.	
CSF Rear	Not Used.	

<b>Group</b>	<b>Item</b>	<b>Settings</b>
Front Feed	TOF	2.12 mm (1/12"), 3.18 mm (1/8"), <b>6.35 mm (1/4")</b> , 8.47 mm (1/3"), 10.58 mm (5/12"), 19.05 mm (9/12"), 23.28 mm (11/12"), 25.4 mm (1"), 27.52 mm (13/12"), 1Chr. Set Pos. <i>Note:</i> 1Chr. Set Pos. automatically appears as the setting when the front panel has been used to set a 1Chr. Set Pos value for the Front Feed path (see page 58).
	Form Tear-Off	<b>Off</b> , On
	Initial Pos.	<b>Print</b> , Tear Off
	PE Pos.	3.18 mm (1/8"), <b>6.35 mm (1/4")</b>
	Gap Control	<b>Auto</b> , Manual Gap x x = 1 to 8, A to E (see page 67)
	Gap Pos.	<b>50.8 mm (2")</b> , 101.6 mm (4")
Rear Feed	Not Used.	
Adjustment	TOF Adj. (Cut)	-40 to <b>0</b> to +40 in increments of 1/120 inch
	TOF Adj.(CSFF)	Not Used.
	TOF Adj.(CSFR)	Not Used.
	Front Load Adj.	-40 to <b>0</b> to +40 in increments of 1/120 inch
	PE Adj. (Cut)	-15 to <b>0</b> to +15 in increments of 1/120 inch
	PE Adj. (CSFF)	Not Used.
	PE Adj. (CSFR)	Not Used.
	PE Adj. (Front)	-15 to <b>0</b> to +15 in increments of 1/120 inch
	PE Adj. (Rear)	Not Used.

<b>Group</b>	<b>Item</b>	<b>Settings</b>
Adjustment (cont.)	1stDotAdjCut	Left x, <b>0</b> , Right y x = 10 through 1 y = 1 through 10 adjustable in increments of 1/180 inch (0.14 mm)
	1stDotAdjAlign	Same as above
	1stDotAdjCSFF	Not Used.
	1stDotAdjCSFR	Not Used.
	1stDotAdjFront	Same as above
	1srDotAdjRear	Not Used.
	Regist. Low	-5 through +5, adjustable in increments of 1/360 inch (0.14 mm)
	Regist. Normal	Same as above
	Regist. High 1	Same as above
	Regist. High 2	Same as above
	LF Revise (Cut)	-10 to <b>0</b> to +10 See table below.
	LF Revise (CSFF)	Not Used.
	LF Revise (CSFR)	Not Used.

# Explanation of Menu Items

The menu items are listed in alphabetical order.

For a summary of the menu groups, items and settings, see “Menu Summary” on page 32

## 1stDotAdjAlign

**Note** *Auto Alignment (see page 41) must be **enabled**.*

Adjusts the set horizontal location for printing the first character on a form when using manual feed from the platform. Selectable settings: Left 10, Left 9, ... Left 2, Left 1, Right 1, Right 2 ... Right 9, Right 10, in increments of 1/180 inch (0.14 mm).

The default is 0.

## 1stDotAdjCut

**Note** *Auto Alignment (see page 41) must be **disabled**.*

Adjusts the set horizontal location for printing the first character on a form when using manual feed from the platform. Selectable settings: Left 10, Left 9, ... Left 2, Left 1, Right 1, Right 2 ... Right 9, Right 10, in increments of 1/180 inch (0.14 mm).

The default is 0.

## 1stDotAdjFront

Adjusts the set horizontal location for printing the first character on a form when using continuous forms (front feed). Selectable settings: Left 10, Left 9, ... Left 2, Left 1, Right 1, Right 2 ... Right 9, Right 10, in increments of 1/180 inch (0.14 mm).

The default is 0.



## **Align1 Pos. Adj.**

## **Align2 Pos. Adj.**

## **Align3 Pos. Adj.**

## **Align4 Pos. Adj.**

**Note** *To use this setting, The corresponding Align 1/ Align 2/ Align 3 / Align 4 setting must be selected for Auto Align or Auto Align (POW).*

Use these to set up to four custom values for the left margin on forms when you are using manual feed from the platform. This represents the distance from the left edge of the page to the left side of the first printed character. Available settings: 0 mm, 5.1 mm [the default], or 45.4 mm. Adjusts within a range of 0 to 45.4 mm, in 1/90-inch [0.26 mm] increments.

## **Auto Align**

When Auto Align is engaged (the printer default), you can use the front panel switches to change to a different preset left margin value (Align 1, 2, 3, or 4). The values are set in the menu under Align1 Pos. Adj., etc.

This lets you quickly switch to another form which requires a different left margin. See page 11 for more information on using the front panel to change Align settings.

If MemoryAutoAlign (see page 47) is set to Valid [the default], whichever Align setting you last used will be saved in memory and engaged the next time you turn on the printer.

**Note** *This setting does not apply when the printer initializes in response to an I-PRIME signal.*

Available settings: Align 1 [the default], Align 2, Align 3, Align 4, or Invalid (skew adjustment disabled).

## Auto Align Detect

Detects and corrects paper skew when manual feed through the platform is being used with Auto Align **enabled** [the default]. Available settings: Valid Level 1, Valid Level 2 [the default], or Invalid.

Change to Valid Level 1 if you wish the detection to be more precise.

Change to Invalid if you are experiencing difficulty getting forms to load into the printer when using preprinted forms with anomalies at the top such as a large dark area on one side or a cutout. Such types of forms defeat the skew sensor.

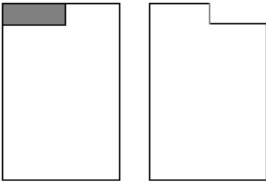

## Auto Align (POW)

**Note** *This setting interacts with the other "Align" items in the Group Manual Feed group (see page 36).*

Sets the alignment method (skew adjustment) engaged for manual feed from the platform *when the printer is turned on.*

**Note** *This setting does not affect the printer when it initializes in response to an I-Prime signal.*

Available settings: Align 1, Align 2, Align 3, Align 4, or SelectAutoAlign [the default].

- *Select Auto Align [the default]:* Skew adjustment is set by Auto Align in the Manual Feed group. (see page 41).
- *Align x (x = 1, 2, 3, or 4):* Skew adjustment is set by the corresponding Alignx Pos.Adj in the Manual Feed group (see page 41).

## Auto CR

IBM emulation only.

The default is No. If you want the printer to automatically add a carriage return when a Line Feed is received at the end of a line, change the setting to Yes.

## Auto Eject Pos.

This sets when the paper ejects, based on the distance between the vertical center of the characters on the last line of the page and the bottom of the page. Choose 3.18 mm (1/8") or 6.35 mm (1/4") [the default].

## Auto Feed XT

The default is Invalid. Change it to Valid if your system uses pin 14 of the parallel interface to control automatic line feed.

## Auto LF

The default is No. If you want the printer to automatically add a line feed, select Yes.

## Buzzer

The default is Enable. Change to Disable to turn off the printer's audible alarm.

## Buzzer Volume

Choose the volume of the buzzer: Low [the default], Middle, or High.

## Character Set

Choose the Character Set: Set I [the default] or Set II.

## Check Print Area

Applies to manual feed from the platform with Auto Alignment enabled. Determines whether or not data which is outside the normal print area specified for the page prints.

The default is Valid: data overflow does *not* print. This prevents such data from printing on the platen.

**Caution! If you change this setting to Invalid, data could print directly on the platen and damage the printhead.**

## Code Page

Choose the Code Page character set you wish to use: USA [the default], Canada French, Multilingual, Portugal, Norway, BRASCII, Abicomp, Multilingual 1858, or ISO-8859=15.

## CutSheet Smooth

Helps to correct for paper curl when feeding in a form manually through the platform. Available settings: Valid [the default] or Invalid.

## Eject Dir.

Choose where the paper is ejected when you are using manual feed from the platform: Front [the default] or Rear.

## Emulation Mode

Choose the printer emulation: Epson LQ [the default], IBM PPR, IBM AGM, or Diablo.

## Form Tear-Off

The default is Off. To activate Form Tear-Off, change the setting to On.

The Forms Tear-Off feature allows a printed continuous form page to be torn off without wasting paper or adjusting the printer.

For more information, see page 61.

## Front Load Adj.

For fine tuning the Top of Form (TOF) location when using continuous forms (front feed). Settable from -40 to +40 in increments of 1/120 inch. The default is 0.

Negative values decrease the space down from the top of the form:

- TOF moves up
- paper moves down.

Positive numbers increase the space down from the top of the form:

- TOF moves down
- paper moves up.

## Gap Control

Sets whether the printhead gap is set automatically [the default] or manually.

## Manual Gap Settings

Setting	Used for
Manual Gap 1	<ul style="list-style-type: none"> <li>• Single sheets 14 to 22 lb. US Bond (52 to 81 g/m<sup>2</sup>)</li> <li>• Thickness range 0.06 to 0.10 mm</li> </ul>
Manual Gap 2	<ul style="list-style-type: none"> <li>• Single sheets 22 to 34 lb. US Bond (81 to 128 g/m<sup>2</sup>)</li> <li>• 2-Part Multi-Part Forms (carbon-backed)</li> <li>• Thickness range 0.10 to 0.15 mm</li> </ul>
Manual Gap 3	<ul style="list-style-type: none"> <li>• Single sheets 34 to 42 lb. US Bond (128 to 156 g/m<sup>2</sup>)</li> <li>• 3-Part Multi-Part Forms (carbon-backed)</li> <li>• Thickness range 0.15 to 0.20 mm</li> </ul>
Manual Gap 4	<ul style="list-style-type: none"> <li>• Postcards</li> <li>• 4-Part Multi-Part Forms (carbon-backed)</li> <li>• Thickness range 0.20 to 0.25 mm</li> </ul>
Manual Gap 5	<ul style="list-style-type: none"> <li>• 5-Part Multi-Part Forms (carbon-backed)</li> <li>• Thickness range 0.25 to 0.30 mm</li> </ul>
Manual Gap 6	<ul style="list-style-type: none"> <li>• 6-Part Multi-Part Forms (carbon-backed)</li> <li>• Thickness range 0.30 to 0.35 mm</li> </ul>
Manual Gap 7	<ul style="list-style-type: none"> <li>• 7-Part Multi-Part Forms (carbon-backed)</li> <li>• Thickness range 0.35 to 0.40 mm</li> </ul>
Manual Gap 8	<ul style="list-style-type: none"> <li>• 8-Part Multi-Part Forms (carbon-backed)</li> <li>• Thickness range 0.40 to 0.45 mm</li> </ul>
Manual Gap A	<ul style="list-style-type: none"> <li>• Heavy paper, 0.45 to 0.50 mm thick</li> </ul>
Manual Gap B	<ul style="list-style-type: none"> <li>• Heavy paper, 0.50 to 0.55 mm thick</li> </ul>
Manual Gap C	<ul style="list-style-type: none"> <li>• Heavy paper, 0.55 to 0.60 mm thick</li> </ul>
Manual Gap D	<ul style="list-style-type: none"> <li>• Heavy paper, 0.60 to 0.65 mm thick</li> </ul>
Manual Gap E	<ul style="list-style-type: none"> <li>• Heavy paper, 0.65 to 0.70 mm thick</li> </ul>

## Gap Pos.

When Auto Gap detection is enabled, this sets how far in from the left edge of the form the gap detection begins: 2 inches (51 mm) [the default] or 4 inches (102 mm).

## Graphics

The default is Bi-directional. Changing to Uni-directional will improve the print registration, but slow the print speed.

## High Skip

The default is Yes. This enables the low-vibration mode, which reduces printer vibration during printing. To switch low-vibration mode off, change this setting to No.

## Hi-Impact Copy

The default is Invalid. Change the setting to Valid if you wish the printer to automatically start up in the Hi-Impact mode when it is turned on. The Valid setting will *not* engage the Hi-Impact mode when the I-Prime (parallel) or Soft\_Reset (USB) commands are received.

## Host Interface

Choose the interface mode: Auto Interface [the default], Parallel, or USB.

## I-Prime

The default is Enable: print out the buffer contents when the I-Prime signal is received. Change to Disable if you wish the printer to ignore the I-Prime signal.

## I/F Time Out

Appears only if Host Interface is set to Auto Interface [the default].

Choose the amount of time the printer waits (while receiving data) before going into idle mode: 15 sec [the default], 30 sec, 45 sec, 1 min, 2 min, 3 min, 4 min, or 5 min.

If your software spends a long time processing between portions of data it feeds to the printer, choose a longer time interval value to keep your printer from dumping the received data while it is waiting for more.

## **Initial Pos.**

Choose where continuous form paper will be positioned when the printer is turned on.

*Print [the default]:* the paper is in a ready-for-printing position.

*Tear:* the paper is at the tear-off position.

## **Language Set**

Replaces certain standard symbols with special characters used in foreign languages. Choose American [the default], French, German, British, Danish 1, Swedish, Italian, Spanish I, Japanese, Norwegian, Danish II, Spanish II, Latin American, French Canadian, Dutch, or Publisher.

## **Line Spacing**

The default is 6 LPI (lines per inch). Change to 8 LPI to get more lines on a page.

## **LF Revise (Cut)**

Adjust the line feed value for manual feed using the platform. Settable from -10 to +10. The default setting is 0.

## **Load LF Speed**

Choose the paper feed speed for inserting sheets when you are using manual feed from the platform: Fast Speed [the default] or Slow Speed.

## **Memory Auto Align**

The default is Valid. This causes the Auto Align setting made using the front panel switches MODE and SHIFT (see page 11) to be stored in the printer's memory. Change to Invalid if you do not wish this value to be stored.

## **Multi Pass**

Select the print direction (Bi-directional: the default, or Uni-directional) for a line containing double-height print.

## **Page Length**

Choose the length of the manual feed paper you are using: 279.4 mm (11") [the default] or 304.8 mm (12").

## Page Width

Choose the width of the continuous forms paper you are using: 8", 10.6", 13.2", or 13.6" [the default].

## Paper End

Choose what happens when paper end is detected when you are using manual feed from the platform: On-line [the default] or Off-line.

## Parallel I/F

Only Nibble Mode supports bi-directional.

Choose the printing used by the parallel interface: Uni-directional or Bi-directional [the default].

## Path Change

Choose whether or not the Tear Off feature (see page 61) is engaged when you change to the continuous forms path. The default is off (Not Tear Off). To set the printer to automatically engage the Form Tear feature when it switches to continuous forms printing, change the setting to Tear Off.

## PE Adj. (Cut) [Paper End Adjust (Manual Feed)]

For fine tuning the location of the last line of printing (Paper End) when using manual feed from the platform. Settable from -15 to +15 in increments of 1/120 inch. The default is 0.

Negative values allow printing further down on the form:

- Paper End moves down
- paper moves up.

Positive values stop the printing further up on the form:

- Paper End moves up
- paper moves down



## **PE Adj. (Front) [Paper End Adjust (Front Feed)]**

For fine tuning the location of the last line of printing (Paper End) when using continuous forms (front feed). Settable from -15 to +15 in increments of 1/120 inch. The default is 0.

Negative values allow printing further down on the form:

- Paper End moves down
- paper moves up.

Positive values stop the printing further up on the form:

- Paper End moves up
- paper moves down

## **PE Pos. [Paper End Position]**

This sets when the the printer will move to the next continuous form, based on the distance between the center of the characters on the last line of the form and the bottom of the form. Available settings: 3.18 mm (1/8") or 6.35 mm (1/4") [the default].

## **Pitch**

Choose the character width, in characters per inch (cpi): 10 [the default], 12, 15, 17.1, or 20 cpi.

## **Power Save Time**

Sets the time the printer waits before entering the Power Save Mode when Power Saving is set to Enable [the default]: 5 min, 10 min [the default], 15 min, 30 min, or 60 min.

## **Power Saving**

Sets whether or not the printer enters the energy-saving Power Save Mode after the interval specified under Power Save Time. The default is Enable.

## **Print Dir. Cmd.**

The default is Valid: the printer will recognize a command for unidirectional printing. Change to Invalid if you do not wish the printer to recognize uni-directional printing commands.

## **Print Mode**

Choose the print quality and speed: LQ Courier [the default], LQ Roman, LQ Swiss, LQ Swiss Bold, LQ Orator, LQ Gothic, LQ Prestige, or Utility.

## **Print Suppress**

The default is No. If your system uses the DC1 and DC3 codes for print suppress mode, change the setting to Yes.

## **Prop. Spacing**

The default is No. Choose Yes to engage proportional spacing of characters.

## **Quiet**

The default is Invalid. Choose Valid to reduce printing noise.

## **Rcv. Buffer**

Sets the amount of memory ( 0 or 128 Kbytes) devoted to holding received data. The default is 128 Kbytes. Changing this to 0 will tie up your computer while printing, but if you abort the print job, the printer will stop much sooner.

## **Regist. Low**

Adjusts the print registration for low-speed printing. Available settings: -5 through +5, in increments of 1/360 inch (0.14 mm).

## **Regist. Normal**

Adjusts the print registration for normal-speed printing. Available settings: -5 through +5, in increments of 1/360 inch (0.14 mm).

## **Regist. High 1**

Adjust the print registration for high-speed printing. Available settings: -5 through +5, in increments of 1/360 inch (0.14 mm).

## **Regist. High 2**

Adjust the print registration for draft mode printing. Available settings: -5 through +5, in increments of 1/360 inch (0.14 mm).

## Reset Inhibit

The default is No. Change this to Yes to prevent your software from resetting your printer's settings. The printer will ignore an INITIAL command.

## Set Alarm

Controls the Paper Set Alarm. Available settings are Valid [the default] or Invalid.

Change to Invalid if the Paper Set Alarm sounds when you try to load preprinted forms with anomalies at the top, such as a large dark area or a cutout. These types of forms defeat the paper sensors.

## SI Pitch (10)

IBM emulation only.

Sets the pitch to be engaged when the printer control panel is set for 10 cpi and the SI command is received. Choose 15 cpi or 17.1 cpi [the default].

## SI Pitch (12)

IBM emulation only.

Sets the pitch to be engaged when the printer control panel is set for 12 cpi and the SI command is received. Choose 12 cpi or 20 cpi [the default].

## Size

The default is Single. Choose Double for double width and height printing.

## Skew Detect

Detects and corrects paper skew when manual feed through the platform is being used with Auto Align **disabled**. Available settings: Valid Level 1, Valid Level 2 [the default], or Invalid.

Change to Valid Level 1 if you wish the detection to be more precise.

Change to Invalid if you are experiencing difficulty getting forms to load into the printer when using preprinted forms with anomalies

at the top such as a large dark area on one side or a cutout. Such types of forms defeat the skew sensor.

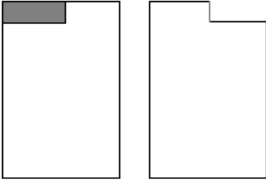

## Skp Ovr Binding

Choose Invalid, Valid 1 [the default] or Valid 2.

### Valid 1

- Continuous forms only
- *before* Form Feeding
- *before* Perforation Skip
- line feeding of 18 mm (.71") or more

### Valid 2

- Continuous forms and manual feed
- *before* Form Feeding

## Skip Over Perf.

Sets what happens when the printer comes within 1-inch (25 mm) of the bottom of the page. The default is No, for use when your software has its own page formatting controls. Change to Yes if you want the printer to go to the next page when it comes within 1" (25 mm) of the bottom of the page.

## Style

The default is Normal. Choose Italic if you want the printed characters to be slanted.

## TOF

Top of Form sets the position down from the top of the page at which printing starts. The default is 6.35 mm (1/4") from the top of the page to the vertical middle of the first print line.

**Note** *The amount of adjustment is limited to avoid paper jams.*

**Manual feed settings:** 2.12 mm (1/12"), 3.18 mm (1/8"), 6.35 mm (1/4"), 7.62 mm (3/10"), 8.47 mm (1/3")\*, 10.58 mm (5/12"), 23.28 mm (11/12"), 25.4 mm (1"), 27.52 mm (13/12"), 1 Chr. Set Pos.

**Continuous form settings:** 2.12 mm (1/12"), 3.18 mm (1/8"), 6.35 mm (1/4"), 8.47 mm (1/3")\*, 10.58 mm (5/12"), 19.05 mm (9/12"), 23.28 mm (11/12"), 25.4 mm (1"), 27.52 mm (13/12"), 1 Chr. Set Pos.

\* When 1/3-inch is selected, the distance is from the top of the page to the top of the first print line, not the vertical middle.

## TOF Adj. (Cut)

For fine tuning the Top of Form (TOF) location when using manual feed from the platform. Settable from -40 to +40 in increments of 1/120 inch. The default is 0.

Negative values decrease the space down from the top of the form:

- TOF moves up
- paper moves down.

Positive numbers increase the space down from the top of the form:

- TOF moves down
- paper moves up.

## Wait Time

**Note** *Auto Alignment (see page 41) must be disabled to use Wait Time.*

*Choose the amount of time the printer waits for paper to be inserted after print data is received when you are using manual feed from the platform: 2.0 sec [the default], 1.5 sec, 1.0 sec, or 0.5 sec.*

## Zero Character

The default is Unslashed. Change to Slashed if you wish to use a slash to distinguish the number zero from the capital letter O.

# Auto Align

The printer is set at the factory for Auto Align enabled. This feature automatically aligns single sheets or forms placed on the platform with the platen as they are drawn into the printer.

Auto Align cannot be used with envelopes. To print envelopes, you must disable Auto Align (see below), then use the sheet guide (1) to load and align the envelope.

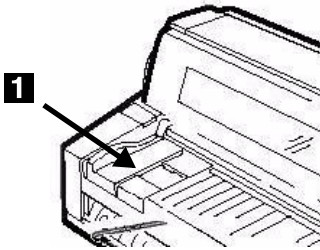

## Disabling Auto Align

To disable Auto Align, you must go into the printer menu:

1. Press SEL.  
*The printer goes off-line.*
2. Simultaneously press SHIFT and MODE.

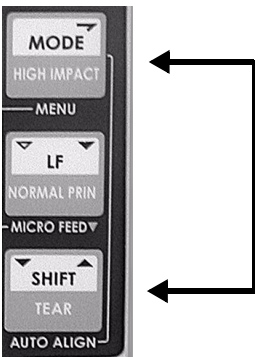

*The printer enters the Menu Mode. **PRINTER CONTROL** displays.*

3. Simultaneously press SHIFT and FF repeatedly until **MANUAL FEED** displays.

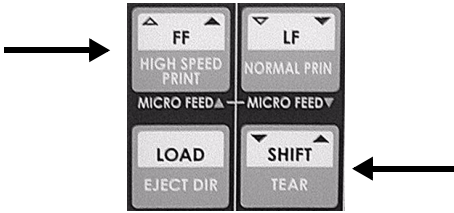

4. Press FF repeatedly until **AUTO ALIGN** displays.



5. Press MODE repeatedly until the setting **INVALID** displays.



6. Press LOAD to save your new setting and exit the menu mode.

# Set Top of Form (TOF)

## General Information

The default top of form is set in the printer menu.

The factory default for TOF is 1/4-inch (6.4 mm), equivalent to the distance down from the top of the sheet to the horizontal midpoint of the first line of printed characters.

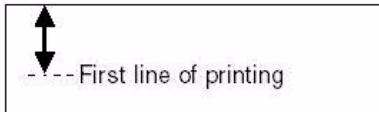

You can establish one custom TOF setting for each feed path (Manual and Front) and store it in the printer's memory as 1Chr Set Pos. This selection will then automatically appear as the setting for TOF for the corresponding group in the Function Setting Menu.

You can also use the control panel switches to set a temporary TOF for one sheet or one continuous form.

## Use the Printer Menu

**Note** The printer default for TOF is 1/4-inch (6.4 mm).

1. Press SEL.

*The printer goes off-line.*

2. Simultaneously press SHIFT and MODE.

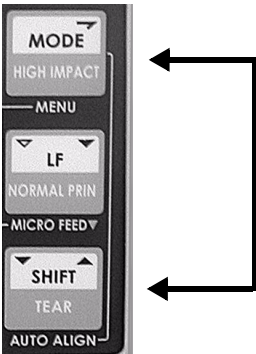

*The printer enters the Function Setting Menu. **PRINTER CONTROL** displays.*



3. Press and hold SHIFT, then press FF repeatedly until the feed path for which you wish to change the TOF appears: **MANUAL FEED** or **FRONT FEED**.

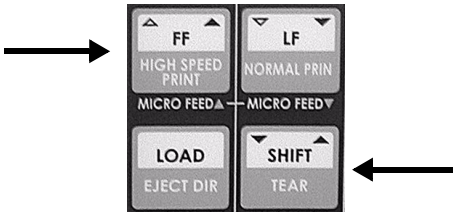

4. Press FF.



**TOF** displays.

5. Press MODE repeatedly until the setting you wish to engage displays: 2.12 mm (1/12"), 3.18 mm (1/8"), 6.35 mm (1/4"), 7.62 mm (3/10"), 8.47 mm (1/3"), 10.58 mm (5/12"), 23.28 mm (11/12"), 25.4 mm (1"), or 27.52 mm (13/12").



6. Press LOAD: this saves your setting and exits the menu mode.



# Use 1Chr Set Pos

You can set and use two different custom Top of Forms:

- Manual Feed (single forms)
- Front Feed (continuous forms).

## Front Feed (Continuous Forms)

1. Make sure the printer is set to the Front Feed path.
2. Press SEL, then press LOAD to park the continuous forms.
3. Simultaneously press SHIFT and SEL.

*The continuous forms move to the printer's default TOF position (1/4-inch [6.4 mm]).*

*The display reads 1CHR. SET POS.*

4. Adjust the print start position as follows:
  - a. If you are fine tuning the TOF you set for a preprinted form, you can move the form to the position you last set for Front Feed 1Chr. Set Pos. by pressing the FF switch.
  - b. To move the *TOF* further *down* on the page (print paper advances further into the printer):
    - In 1/180-inch (0.14 mm) increments: press and hold the SHIFT switch, then press FF.
    - In 10/180-inch (1.41 mm) increments: press and hold the SHIFT switch, then press SEL.
    - One line at a time: press FF.
  - c. To move the *TOF* further *up* on the page (print paper retracts further out of the printer):
    - In 1/180-inch (0.14 mm) increments: press and hold the SHIFT switch, then press LF.
    - In 10/180-inch (1.41 mm) increments: press and hold the SHIFT switch, then press MODE.
5. Store the TOF position in the printer's memory:
  - a. To store the position as the 1Chr. Set Pos setting, press the SEL switch. The setting will be retained, even if you turn the printer off, until you use this procedure to change the setting. This also automatically sets the TOF setting in the Front Feed group to 1Chr. Set Pos.

**Note** *If you reset the printer to the factory defaults, the 1Chr. Set Pos you have established will be deleted.*

- b. To store the position in the printer's memory only until it is turned off or it receives an I-Prime signal, press the LOAD switch.

6. Press SEL to return the printer to the on-line state.

## Manual Feed (Single Sheets/Forms)

1. Make sure the printer is set to the Manual Feed path.
2. Press SEL, then press LOAD to remove the paper from the paper path.
3. Simultaneously press SHIFT and SEL.

*The SEL light starts blinking and the display reads*

*1CHR. SET MODE*

*INSERT PAPER.*

4. Load a sheet/form on the platform.

*The sheet/form advances to the printer's default TOF (1/4-inch [6.4 mm]) and the display reads 1CHR. SET POS.*

5. Adjust the print start position as follows:

- a. If you are fine tuning the TOF you set for a preprinted form, you can move the sheet/form to the position you last set for Manual Feed 1Chr. Set Pos. by pressing the FF switch.
- b. To move the *TOF* further *down* on the page (print paper advances further into the printer):
  - In 1/180-inch (0.14 mm) increments: press and hold the SHIFT switch, then press FF.
  - In 10/180-inch (1.41 mm) increments: press and hold the SHIFT switch, then press SEL.
  - One line at a time: press FF.
- c. To move the *TOF* further *up* on the page (print paper retracts further out of the printer):
  - In 1/180-inch (0.14 mm) increments: press and hold the SHIFT switch, then press LF.
  - In 10/180-inch (1.41 mm) increments: press and hold the SHIFT switch, then press MODE.

6. Store the TOF position in the printer's memory:

- a. **To store the position as the 1Chr. Set Pos setting**, press the SEL switch. The setting will be retained, even if you turn the printer off, until you use this procedure to change the setting. This also automatically sets the TOF setting in the Manual Feed group to 1Chr. Set Pos.

**Note** *If you reset the printer to the factory defaults, the 1Chr. Set Pos you have established will be deleted.*

- b. **To store the position in the printer's memory only until it is turned off or receives an I-Prime signal**, press the LOAD switch.

7. Press SEL to return the printer to the on-line state.

## Temporary TOF

### Use the Control Panel

This TOF setting applies only to the sheet or continuous form loaded into the printer when the setting is made. The next sheet or form feeds to the selected default TOF.

1. With paper loaded in the print path, press SEL to put the printer offline.
2. Change the location of the first line of printing:
  - a. To move the *TOF* further *down* on the page (print paper advances further into the printer):
    - In 1/180-inch increments: press and hold the SHIFT switch, then press FF.
    - One line at a time: press FF.
  - b. To move the *TOF* further *up* on the page (print paper retracts further out of the printer):
    - In 1/180-inch increments: press and hold the SHIFT switch, then press LF.
3. Press SEL to return the printer to the on-line state.
4. Send the print job.

# Form Tear Off

The Form Tear Off feature allows you to advance continuous forms to the stacker for tear off.

The printer default for Forms Tear Off is Off. To use this feature, you must enter the Function Settings Menu and turn it on.

## Turn On Forms Tear Off

1. Press SEL.

*The printer goes off-line.*

2. Simultaneously press SHIFT and MODE to enter the Function Settings Menu.

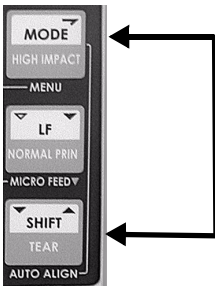

**PRINTER CONTROL** displays.

3. Press and hold SHIFT, then press FF repeatedly until **FRONT FEED** displays.

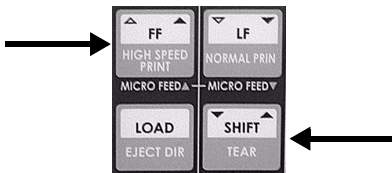

4. Press FF repeatedly until **FORM TEAR-OFF** displays.



5. Press MODE.



*The setting changes to **ON**.*

6. Press LOAD: this saves your setting and exits the menu mode.

# Move Continuous Forms Up for Tear Off

1. Press the SEL switch to deselect the printer.
2. Press and hold the SHIFT and SEL switches to move continuous forms to the tear off position.

# Tests

## Rolling ASCII Test

**Note** *When the printer is running a test, it always uses a left margin of 5.1 mm (0.2-inch).*

This test provides a one-page continuous printout of the ASCII characters.

1. Turn off the printer.
2. Simultaneously press and hold the LF and FF switches while turning on the printer.
3. Load a sheet of paper on the platform.
4. The Rolling ASCII test will run and the sheet will eject.

## Font Sample Test

**Note** *When the printer is running a test, it always uses a left margin of 5.1 mm (0.2-inch).*

This test provides a sample of each of the available fonts in the printer.

**Note** *The Font Sample test takes two letter-size sheets.*

1. Turn off the printer.
2. Simultaneously press and hold the MODE and LF switches while turning on the printer.
3. Load a sheet of paper on the platform.
4. The Font Sample test will run and the sheet will eject.
5. Remove the first printed sheet from the platform and load another sheet.
6. The test finishes printing and the sheet ejects.

# Hex Dump Mode

**Note** *When the printer is running a test, it always uses a left margin of 5.1 mm (0.2-inch).*

When the printer is in the Hex Dump Mode, all data received, including text and printer commands, will be printed in both hexadecimal and ASCII format.

**Note** *In the ASCII format, all non-printable characters will be represented by a period.*

## Engaging the Hex Dump Mode

1. Be sure paper is loaded.
2. Turn the printer off.
3. Simultaneously press and hold the **MODE + LF + SHIFT** switches while turning the printer on, until **RELEASE SW** displays.

**HEXDUMP NORMAL** displays and "Hex Dump Mode" prints at the top of the paper.

## Running a Hex Dump Test

To run the test, send data to the printer while it is in the Hex Dump Mode.

## Exiting Hex Dump Mode

Turn the printer off, then on again.



# Setting the Printhead Gap

## General Information

The printhead gap is the distance between the printhead and the platen.

Your printer comes from the factory set to automatically detect the printhead gap (Auto Gap selected) for the media being fed in. Certain media, especially media with uneven thickness, may not work well with the Auto Gap feature and could produce unsatisfactory print results.

To correct for this, change from Auto Gap to a manually set gap. You may need to experiment a bit to determine the best manual setting for a particular media.

**Note** *Because their thickness varies, envelopes do not work with Auto Gap.*

# Printhead Gap Settings

Setting	Used for
Manual Gap 1	<ul style="list-style-type: none"><li>• Single sheets 14 to 22 lb. US Bond (52 to 81 g/m<sup>2</sup>)</li><li>• Thickness range 0.06 to 0.10 mm</li></ul>
Manual Gap 2	<ul style="list-style-type: none"><li>• Single sheets 22 to 34 lb. US Bond (81 to 128 g/m<sup>2</sup>)</li><li>• 2-Part Multi-Part Forms (carbon-backed)</li><li>• Thickness range 0.10 to 0.15 mm</li></ul>
Manual Gap 3	<ul style="list-style-type: none"><li>• Single sheets 34 to 42 lb. US Bond (128 to 156 g/m<sup>2</sup>)</li><li>• 3-Part Multi-Part Forms (carbon-backed)</li><li>• Thickness range 0.15 to 0.20 mm</li></ul>
Manual Gap 4	<ul style="list-style-type: none"><li>• Postcards</li><li>• 4-Part Multi-Part Forms (carbon-backed)</li><li>• Thickness range 0.20 to 0.25 mm</li></ul>
Manual Gap 5	<ul style="list-style-type: none"><li>• 5-Part Multi-Part Forms (carbon-backed)</li><li>• Thickness range 0.25 to 0.30 mm</li></ul>
Manual Gap 6	<ul style="list-style-type: none"><li>• 6-Part Multi-Part Forms (carbon-backed)</li><li>• Thickness range 0.30 to 0.35 mm</li></ul>
Manual Gap 7	<ul style="list-style-type: none"><li>• 7-Part Multi-Part Forms (carbon-backed)</li><li>• Thickness range 0.35 to 0.40 mm</li></ul>
Manual Gap 8	<ul style="list-style-type: none"><li>• 8-Part Multi-Part Forms (carbon-backed)</li><li>• Thickness range 0.40 to 0.45 mm</li></ul>
Manual Gap A	<ul style="list-style-type: none"><li>• Heavy paper, 0.45 to 0.50 mm thick</li></ul>
Manual Gap B	<ul style="list-style-type: none"><li>• Heavy paper, 0.50 to 0.55 mm thick</li></ul>
Manual Gap C	<ul style="list-style-type: none"><li>• Heavy paper, 0.55 to 0.60 mm thick</li></ul>
Manual Gap D	<ul style="list-style-type: none"><li>• Heavy paper, 0.60 to 0.65 mm thick</li></ul>
Manual Gap E	<ul style="list-style-type: none"><li>• Heavy paper, 0.65 to 0.70 mm thick</li></ul>

# Change to a Manual Printhead Gap Setting

## “On-the-Fly”

If you are switching to a different print media and wish to temporarily change the printhead gap setting for that media, you can use the control panel switches to change the printhead gap setting. The setting will be maintained until the printer is turned off or until it receives an I-Prime signal.

You can also use this feature to try different settings for your media, then set the best one(s) as the printer default in the Function Settings Menu (see below).

1. Press the SEL switch to deselect the printer.
2. Press and hold the SHIFT switch, then press the LOAD switch repeatedly to scroll through the various settings for the printhead gap.
3. When the desired setting appears on the display, press the SEL switch to place the printer back on line.

## Change to a Manual Printhead Gap Setting

### In the Menu

If you wish to change the printhead gap and continue to use the manual setting even if the printer is turned off, it must be done in the Function Setting Menu.

You can establish two different printhead gap settings in the menu: one in the Manual Feed group and one in the Form Feed group.

1. Press the SEL switch to deselect the printer.
2. Press SEL.  
*The printer goes off-line.*
3. Simultaneously press SHIFT and MODE.

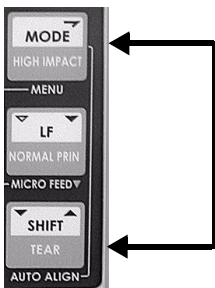

**PRINTER CONTROL** displays.

4. Press and hold SHIFT, then press FF repeatedly until **MANUAL FEED** displays.

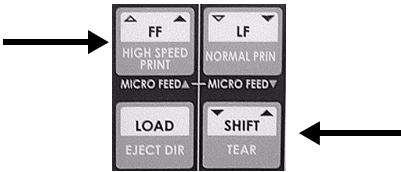

5. Press FF repeatedly until **GAP CONTROL** displays.



6. Press MODE repeatedly until the desired printhead gap setting appears on the display.



7. Press and hold SHIFT, then press FF repeatedly until **FRONT FEED** displays.



8. Press FF repeatedly until **GAP CONTROL** displays.



9. Press MODE repeatedly until the desired printhead gap setting appears on the display.



10. Press LOAD: this saves your setting and exits the menu mode.



# Troubleshooting

## Paper Jams: Single Sheet

If a paper jam is indicated on the display panel, use the following method to clear it.

**Caution!** *Do not open the access cover with the power on, as injury may result.*

**Caution!** *The printhead may be very hot after printing. Allow the printhead to cool before touching it.*

1. Turn OFF the power switch.
2. Open the cover and move the printhead [**Caution! Printhead may be HOT!**] to an area off the sheet of paper.

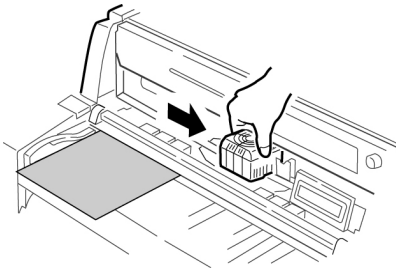

3. Turn the platen knob forward or backward to bring out the jammed sheet.

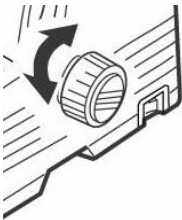

# Paper Jams: Continuous Forms

If a paper jam is indicated on the display panel, use the following method to clear it.

**Caution!** *Do not open the access cover with the power on, as injury may result.*

**Caution!** *The printhead may be very hot after printing. Allow the printhead to cool before touching it.*

1. Turn OFF the power switch.
2. Tear off the continuous form from the paper stack.

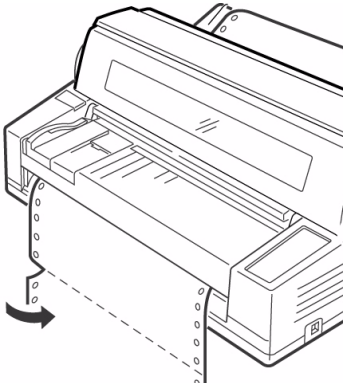

3. Turn the platen knob to bring out the continuous forms.

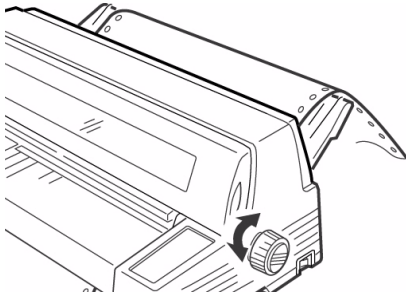

# Paper Jams: Correcting Repetitive Jams

If a paper jam is indicated on the display panel, use the following method to clear it.

**Caution!** *Do not open the access cover with the power on, as injury may result.*

**Caution!** *The printhead may be very hot after printing. Allow the printhead to cool before touching it.*

If paper keeps jamming you probably have bits of paper stuck in the paper path.

1. If you have continuous forms loaded, park the paper by pressing SEL to deselect the printer, then pressing LOAD.
2. Turn OFF the printer.
3. Open the cover and remove any visible pieces of paper with a pair of tweezers.

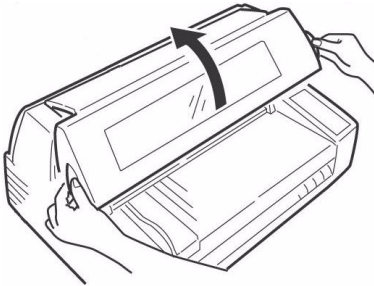

4. Fold a single sheet into three thicknesses.

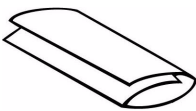

5. Place the folded sheet on the platform and feed it through by turning the platen knob.

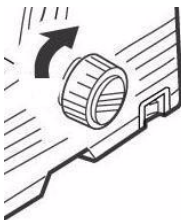

6. Remove any bits of paper that come out.
7. Use the platen knob to remove the continuous forms paper.

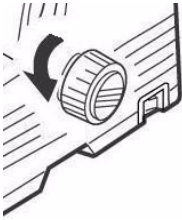

8. Lift the sheet feed platform.

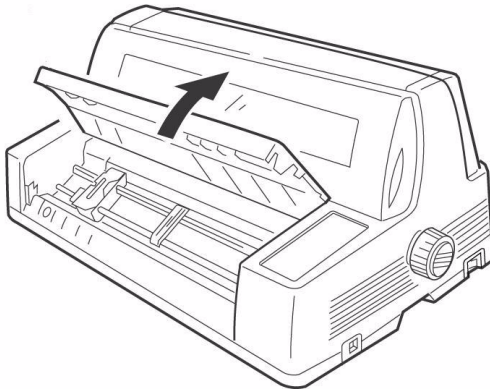

9. Fold some single-sheet thick continuous forms paper over three times to make a page four sheets thick, then load it on the tractors.
10. Use the platen knob to draw the quadruple-thick form around the platen and out of the printer.

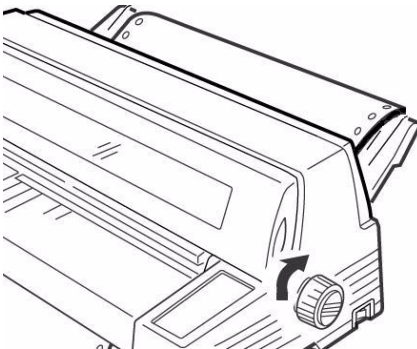

11. Remove any bits of paper that come out.



**12.** Reload your continuous forms paper.

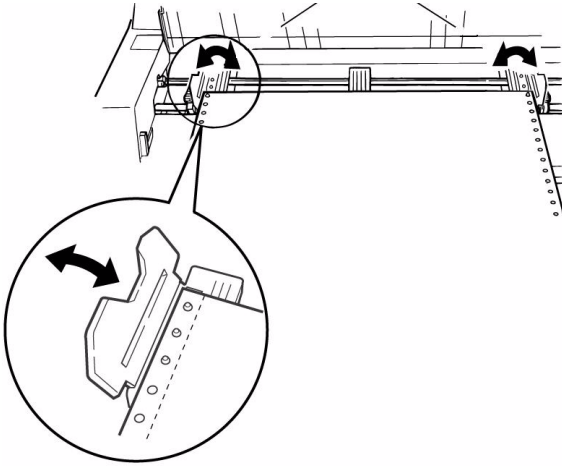

**13.** Close the sheet feed platform and the cover.

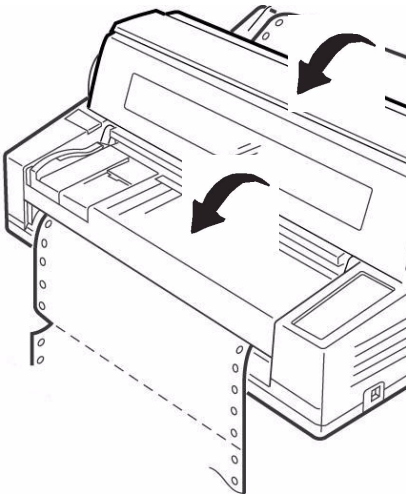

**14.** Turn on the printer.

# Error Messages

## **Manual paper End Insert Paper**

Load paper on the platform and press SEL.

## **Paper end alignx insert paper**

Load paper on the platform and press SEL.

## **Front Paper End Insert Paper**

Load continuous forms paper on the tractors.

## **Paper Jam Remove paper**

Remove the jammed paper (see page 69) and press SEL.

## **Data Present Insert Paper**

The printer has received data, but there is no print media loaded in the selected path. Load print media.

## **Data Present Press SEL Sw**

The printer has received data and paper is loaded, but the printer is off line. Press the SEL switch to place the printer on line.

## **Path Changing Remove Cut Sheet**

The printer is attempting to change paper paths from Manual Feed to Front Feed, but print media is loaded on the platform. Remove the media from the platform.

## **Cover Open Close Cover**

Close the top cover.

## **Paper Feed Alarm Re-Set Paper**

Print media on the platform has miss-fed into the printer. Press SEL, then press LOAD to eject the media, then try loading it again.

**Paper Set Alarm****Re-Set Paper**

The paper is not installed correctly. Remove and reinstall it.

**Left Margin Err****Check Margin**

The left margin setting needs to be adjusted for the print media. Check to be sure that the Align x Pos. Adjust value you have selected (see page 41) is appropriate.

**Head Thermal****Single Pass**

The printhead has a thermal sensor which has detected that the printhead is too hot. The printer has switched to uni-directional printing until the printhead cools down.

**High Duty Print****Single Pass**

The print density is high and the printer has switched to uni-directional printing.

**Gap NG****Reload**

The printhead gap has been set to a manual setting that does not suit the media. Change the setting or restore it to the default Auto Gap before printing.

# Maintenance

## Replace the Ribbon

**Note** *The replacement part number for the ribbon cartridge is 41708209. Use only genuine OKI replacement ribbons.*

1. Turn off the printer.
2. Open the cover.
3. Tilt the display panel forward.
4. Pull the ribbon out a bit at the left end of the cartridge to give some slack, then unthread it from the printhead.

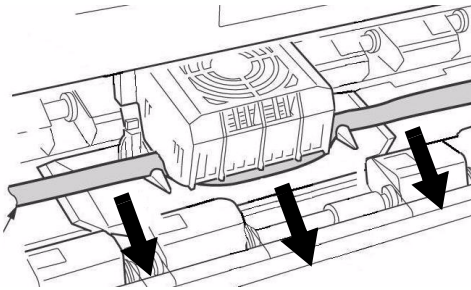

5. Remove the used ribbon cartridge and discard it in accordance with local regulations.

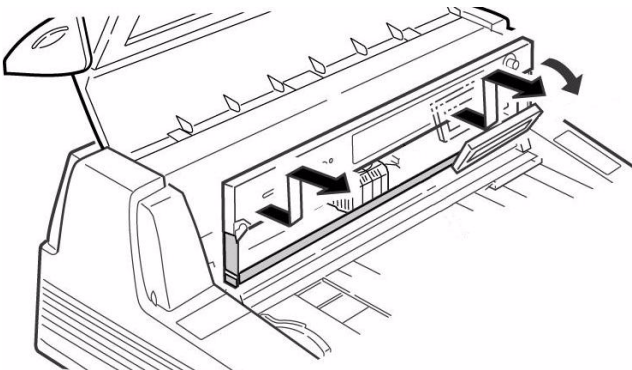

6. Unpack the ribbon cartridge and remove the lock pieces (1).

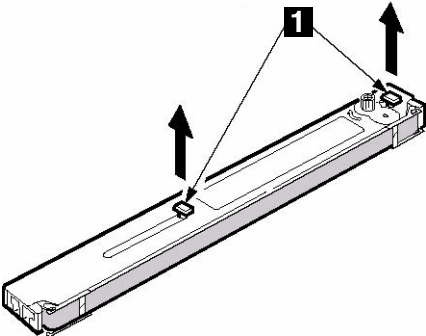

7. Swing out the ribbon arms on either end of the cartridge until they *snap* into place.

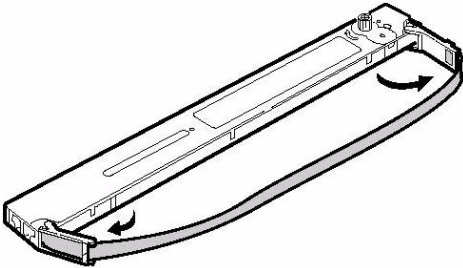

**8.** Feed the ribbon arms (1) in beside the guides (2), position the take-up knob (3) over the pin, then press the cartridge in firmly at either end.

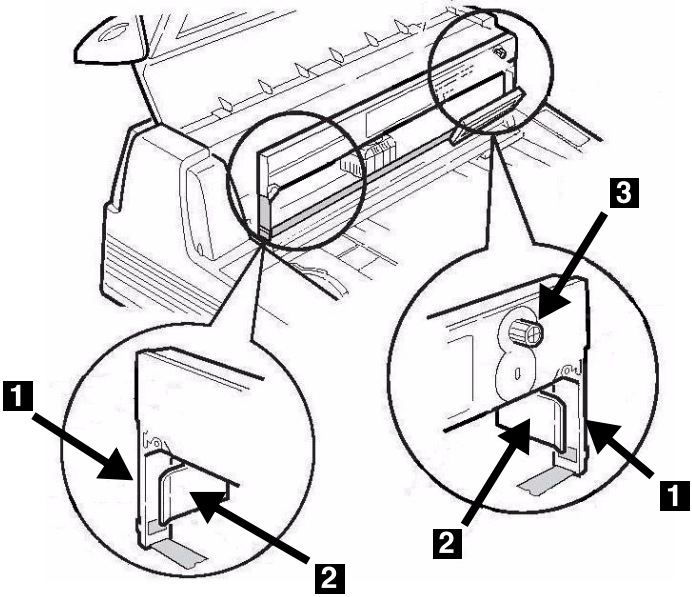

**9.** Pull the ribbon out a bit at the left end of the cartridge to give some slack, then slide the ribbon underneath the printhead. Be careful that the ribbon is not twisted, folded or pulled off the ribbon arms during this process.

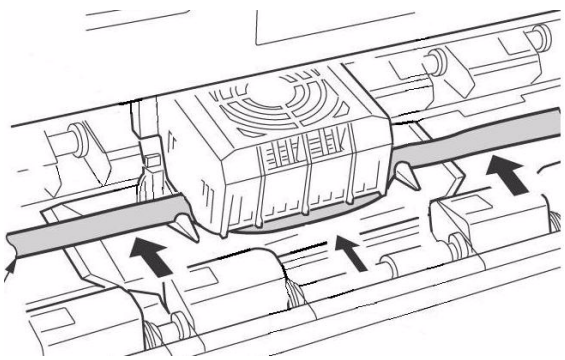

10. Make sure the ribbon is threaded through the indentation in each ribbon guide arm.

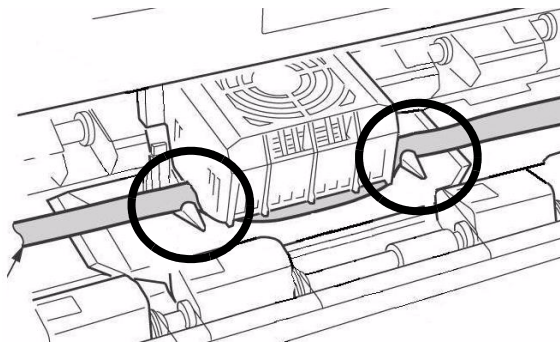

**Caution!**

**Always turn the ribbon knob *clockwise* (to the right): turning it *counterclockwise* (to the left) can cause the ribbon to jam.**

11. Turn the ribbon knob *clockwise* (in the direction of the molded arrow) to take up any excess slack in the ribbon.

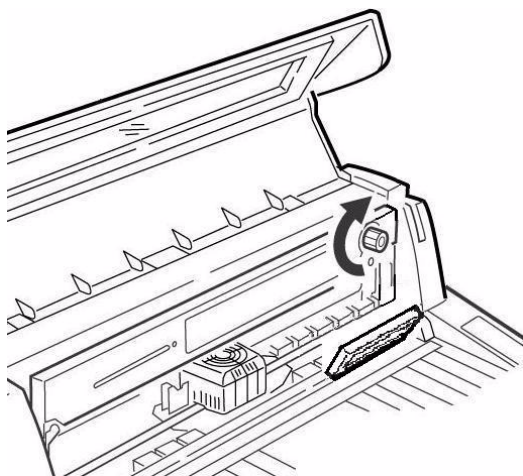

**12.** Push the display panel back to its original position.

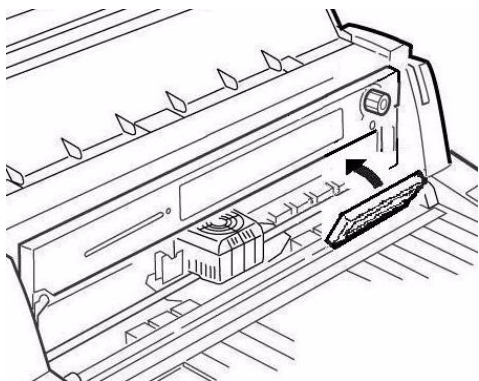

**13.** Close the cover.

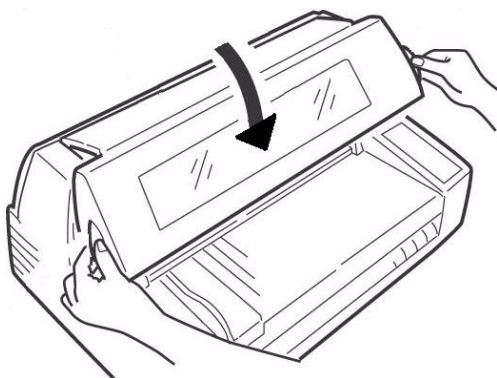

**Caution!**

**If the cover does not close easily, do not force it. The right end of the ribbon cartridge is not properly seated in the printer. Open the cover and reseal it. Then reclose the cover.**

**14.** Turn the printer back on.



# Clean the Housing

You should clean the inside of the printer every six months (or after about 300 hours of operation).

**Note** *If you are consistently using recycled paper, you need to clean the housing more often because recycled paper generates more paper dust.*

## Caution!

**Never use solvents or strong detergents on the cabinet: they could damage the housing.**

1. Turn the printer off and remove any paper that is loaded.
2. Open the platform and use a clean, dry cloth to clean away any bits of paper and paper dust.

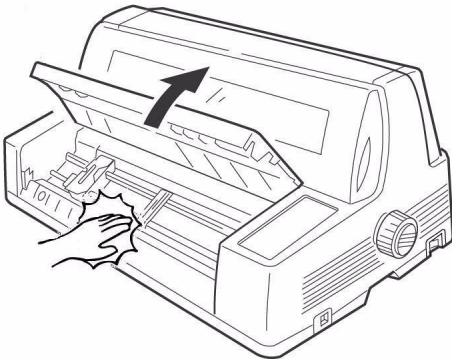

3. Close the platform.
4. Open the cover.
5. Tilt the display panel forward and remove the ribbon cartridge.

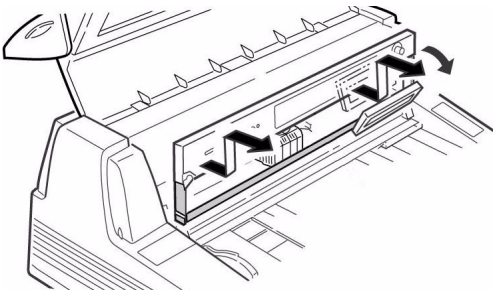

6. Use a clean, dry cloth to clean any bits of paper or paper dust from around the platen.

- 7.** Replace the ribbon cartridge (see page 76 for more information) and tilt the display panel back into place.
- 8.** Close the cover.

# Control Codes

## In Sequence by ASCII Code

ASCII Code	Function	Emulation(s)
BEL	BELL	Diablo
BS	BACKSPACE	Epson LQ / IBM / Diablo
CAN	CANCEL CODE	Epson LQ / IBM
CR	CARRIAGE RETURN	Epson LQ / IBM / Diablo
DC1	RESET PRINT SUPPRESS MODE	Epson LQ / IBM
DC2	RESET COMPRESSED CHARACTER PITCH	Epson LQ
DC2	SET 10 CPI	IBM
DC3	SET PRINT SUPPRESS	Epson LQ
DC4	RESET IMMEDIATE DOUBLE WIDTH CHARACTERS	Epson LQ / IBM
DEL	ONE CHARACTER DATA DELETE	Epson LQ
DEL	IGNORE	Diablo
ESC - n	SET/RESET UNDERLINING	Epson LQ / IBM / Diablo
ESC ! n	PRINT MODE SELECT	Epson LQ / Diablo
ESC ! n	SELECT INTERNATIONAL CHARACTER SET	IBM
ESC #	RESET 8 BIT MODE	Epson LQ / Diablo
ESC \$ n1 n2	EXECUTE ABSOLUTE HORIZONTAL DOT POSITION	Epson LQ / Diablo
ESC % 4 n	FINE LINE FEED (n/360 INCH)	IBM
ESC % 8 n	SET n/360 INCH LINE SPACING	IBM
ESC % G	SET ITALICS CHARACTER	IBM
ESC % H	RESET ITALICS CHARACTERS	IBM
ESC % n	DLL FONT SELECT	Epson LQ / Diablo
ESC % T	SELECT EJECTS DIRECTION	Epson LQ / IBM
ESC &	END BOLD/SHADOW PRINTING	Diablo
ESC & m n1 n2 d0 d1 d2 <DLL data>	CHARACTER DEFINITION	Epson LQ

<b>ASCII Code</b>	<b>Function</b>	<b>Emulation(s)</b>
ESC ( t	ASSIGN CHARACTER TABLE	Epson LQ
ESC * m n1 n2 <graphics data>	ENTER/EXIT BIT IMAGE GRAPHICS	Epson LQ / IBM XL24 AGM / Diablo
ESC / n	SELECT VERTICAL TAB CHANNEL	Epson LQ / Diablo
ESC :	SET 12 CPI	IBM
ESC : NUL n NUL	COPIES ROM CG TO RAM CG	Epson LQ / Diablo
ESC ? m n	REASSIGN ALTERNATE GRAPHICS CODES	Epson LQ / Diablo
ESC @	PRINTER INITIALIZATION	Epson LQ
ESC @ A n	SET LINE SPACING IN 1/120-INCH INCREMENTS	Diablo
ESC @ E n	SET EMULATION	Diablo
ESC @ F n	SET FONT	Diablo
ESC @ H n	START/END DOUBLE-HIGH PRINTING	Diablo
ESC @ P n	SET PRINT QUALITY (SPEED)	Diablo
ESC @ T n	SELECT BIN	Diablo
ESC @ V n	START/END SUPER/SUBSCRIPT	Diablo
ESC @ W n	START/END DOUBLE-WIDE PRINTING	Diablo
ESC @ Z n	SET CHARACTER CELL SIZE	Diablo
ESC [ @ n1 n2 m1 m2 m3 m4	SET/RESET DOUBLE HEIGHT CHARACTERS	IBM
ESC [ \ 4 0 0 0 n1 n2	SET VERTICAL UNITS	IBM
ESC [ g n1 n2 m data	GRAPHICS RESOLUTION	IBM XL24
ESC [ n	SET n/360 INCH FINE LINE SPACING	Epson LQ
ESC [ T	SET CODE PAGE	IBM
ESC \ n1 n2	EXECUTE RELATIVE DOT POSITION	Epson LQ / Diablo
ESC \ n1 n2	PRINT CONTINUOUSLY FROM ALL CHARACTERS CHART	IBM
ESC ]	REVERSE LINE FEED	IBM
ESC ] n	FINE LINE FEED (n/360 INCH)	Epson LQ / Diablo
ESC ^	PRINT ONE CHARACTER FROM ALL CHARACTERS CHART	IBM

<b>ASCII Code</b>	<b>Function</b>	<b>Emulation(s)</b>
ESC _ n	OVERSCORE SET/RESET	IBM
ESC { n	SELECT EMULATION MODE	Epson LQ / IBM / Diablo
ESC   01H 01H 00H n	SELECT EJECT DIRECTION	Epson LQ / Diablo
ESC   05H 01H 00H n	PERFORM n/360-INCH LF	Epson LQ / Diablo
ESC   10H 02H 00H n1 n2	SELECT HEAD GAP	Epson LQ / Diablo
ESC   12H 02H 00H 01H n	SELECT PAPER PATH	Epson LQ / Diablo
ESC } NUL	SOFTWARE I-PRIME	Epson LQ / IBM / Diablo
ESC +	SELECT N/360 m LINE SPACING	Epson LQ
ESC <	ONE LINE UNIDIRECTIONAL PRINTING	Epson LQ / Diablo
ESC =	SET BIT 7 CODE TO 0	Epson LQ / Diablo
ESC = n1 n2 ... <data>	LOAD DLL CHARACTER	IBM
ESC >	SET BIT 7 CODE TO 1	Epson LQ
ESC 0	SET 1/8 INCH FIXED LINE SPACING	Epson LQ / IBM
ESC 1	SET 7/72 INCH FIXED LINE SPACING	IBM
ESC 1 n	SELECT 7/72 LINE SPACING	Diablo
ESC 2	SET 1/6 INCH LINE SPACING	Epson LQ / Diablo
ESC 2	START LINE SPACING	IBM
ESC 3 n	SET n/180 INCH LINE SPACING	Epson LQ / IBM PPR/IBM XL24/Diablo
ESC 4	SET ITALIC CHARACTERS	Epson LQ / Diablo
ESC 4	TOP OF FORM SET	IBM
ESC 5	RESET ITALIC CHARACTERS	Epson LQ / Diablo
ESC 5 n	SET/RESET AUTOMATIC LINEFEED	IBM
ESC 6	SELECT CHARACTER SET II	IBM
ESC 6	DISABLE UPPER ASCII CONTROL CODE	Epson LQ / Diablo
ESC 7	SELECT CHARACTER SET I	IBM

<b>ASCII Code</b>	<b>Function</b>	<b>Emulation(s)</b>
ESC 7	ENABLE UPPER ASCII CONTROL CODES	Epson LQ / Diablo
ESC 9	SET LEFT MARGIN	Diablo
ESC a n	AUTO JUSTIFICATION	Epson LQ / Diablo
ESC A n	SET N/60 INCH LINE SPACING	Epson LQ / IBM PPR/IBM XL24/Diablo
ESC b n m1 m2 ... mk NUL	SET VERTICAL FORMAT UNIT (VFU)	Epson LQ / Diablo
ESC B n1 n2 ... nk NUL	SET VERTICAL TAB STOPS	Epson LQ / IBM / Diablo
ESC BS	BACKSPACE	Diablo
ESC C	RESET TOP MARGIN	Diablo
ESC C n	FORM LENGTH SET BY LINES	Epson LQ / IBM
ESC C NUL n	FORM LENGTH SET BY INCHES	Epson LQ / IBM
ESC CR P	RESET PRINTER	Diablo
ESC D	REVERSE HALF-LINE FEED	Diablo
ESC d n1 n2	MOVE RIGHT RELATIVE DOT POSITION	IBM
ESC D n1 n2 ... nj nk NUL	HORIZONTAL TAB SET	Epson LQ / IBM
ESC e	RELATIVE MOVE INLINE BACKWARD	IBM
ESC E	SET EMPHASIZED PRINT MODE	Epson LQ / IBM
ESC E	START AUTOMATIC UNDERSCORING	Diablo
ESC EM	PERFORM SHEETFEEDER OPERATION	Diablo
ESC EM n	CUT-SHEET FEEDER CONTROL	Epson LQ / IBM
ESC F	RESET EMPHASIZED PRINT MODE	Epson LQ / IBM / Diablo
ESC FF	SET LINES PER PAGE	Diablo
ESC g	SET 15 CHARACTER PER INCH	Epson LQ / IBM / Diablo
ESC G	SET ENHANCED/DOUBLE STRIKE PRINT MODE	Epson LQ / IBM / Diablo
ESC H	RESET ENHANCED/DOUBLE STRIKE PRINT MODE	Epson LQ / IBM

<b>ASCII Code</b>	<b>Function</b>	<b>Emulation(s)</b>
ESC HT n1	EXECUTE ABSOLUTE HORIZONTAL POSITION	Diablo
ESC I n	PRINT MODE SELECT	IBM
ESC I n	LEFT MARGIN SET	Epson LQ / Diablo
ESC j	STOP PRINTING	IBM
ESC j n	REVERSE LINE FEED	Epson LQ / Diablo
ESC J n	FINE LINE FEED (n/180 INCH)	Epson LQ / IBM PPR/IBM XL24
ESC k n	SELECT TYPESTYLES	Epson LQ / IBM / Diablo
ESC K n1 n2 <graphics data>	SINGLE DENSITY GRAPHICS	Epson LQ / IBM / Diablo
ESC L n1 n2 <graphics data>	DOUBLE DENSITY GRAPHICS	Epson LQ / IBM / Diablo
ESC LF	REVERSE LINE FEED	Diablo
ESC M	SET ELITE CHARACTER PITCH (12 CPI)	Epson LQ / Diablo
ESC n	SET ASPECT RATIO	IBM
ESC N n	SET PERFORATION AUTO SKIP	Epson LQ / IBM / Diablo
ESC O	RESET PERFORATION AUTO SKIP	Epson LQ / IBM
ESC O	START BOLD PRINTING	Diablo
ESC P	SET PICA CHARACTER PITCH (10 CPI)	Epson LQ / Diablo
ESC p n	SET/RESET PROPORTIONAL SPACING	Epson LQ / Diablo
ESC P n	SET/RESET PROPORTIONAL SPACING	IBM
ESC q n	SELECT CHARACTER STYLE	Epson LQ / IBM / Diablo
ESC Q n	PRINT SUPPRESS	IBM
ESC Q n	RIGHT MARGIN SET	Epson LQ
ESC R	RESET TABLE SETTINGS TO POWER-ON DEFAULT VALUES	IBM
ESC R	END AUTOMATIC UNDERSCORING	Diablo
ESC R n	FOREIGN CHARACTER SET SELECT	Epson LQ
ESC RS n	SET LINE SPACING IN 1/48-INCH INCREMENTS	Diablo

<b>ASCII Code</b>	<b>Function</b>	<b>Emulation(s)</b>
ESC s n	SET/RESET HALF SPEED PRINTING	Epson LQ / Diablo
ESC S n	SET SUBSCRIPT/SUPERSCRIPT	Epson LQ / IBM / Diablo
ESC SI	SET COMPRESSED CHARACTER PITCH	Epson LQ / Diablo
ESC SI	SET 20 CPI	IBM
ESC SO	SET IMMEDIATE DOUBLE CHARACTERS	Epson LQ / Diablo
ESC SP n	SET CHARACTER SPACING	Epson LQ / Diablo
ESC T	RESET SUPER/SUBSCRIPT	Epson LQ / IBM
ESC T	SET TOP MARGIN	Diablo
ESC t n	SELECT CHARACTER TABLE	Epson LQ / Diablo
ESC U	HALF-LINE FEED	Diablo
ESC U n	SET/RESET UNIDIRECTIONAL PRINTING	Epson LQ / IBM
ESC US n	SET/RESET DOUBLE HEIGHT CHARACTERS	Epson LQ
ESC US n	SET CHARACTER PITCH	Diablo
ESC VT	ABSOLUTE MOVE TO PRINT LINE	Diablo
ESC W	START SHADOW PRINTING	Diablo
ESC w a	SET NLQ MODE	Diablo
ESC w n	SET/RESET DOUBLE HEIGHT CHARACTERS	Epson LQ
ESC W n	SET DOUBLE WIDTH OR EXPANDED CHARACTERS	Epson LQ / IBM
ESC x n	SELECT CHARACTER FONT	Epson LQ / Diablo
ESC X n1 n2	SET LEFT/RIGHT MARGIN	IBM
ESC Y n1 n2 <graphics data>	QUASI-DOUBLE DENSITY GRAPHICS	Epson LQ / IBM / Diablo
ESC Z n1 n2 <graphics data>	SET QUADRUPLE DENSITY GRAPHICS	Epson LQ / IBM / Diablo
ESC z n1 n2 n3	EXECUTE ABSOLUTE HORIZONTAL POSITION	Diablo
FF	FORM FEED	Epson LQ / IBM / Diablo
GS	PRINT CHARACTER WITH CODE BELOW 20 HEX	Diablo



<b>ASCII Code</b>	<b>Function</b>	<b>Emulation(s)</b>
HT	HORIZONTAL TAB	Epson LQ / IBM / Diablo
LF	LINE FEED	Epson LQ / IBM / Diablo
SI	SET COMPRESSED CHARACTER PITCH	Epson LQ / IBM / Diablo
SO	SET IMMEDIATE DOUBLE WIDTH CHARACTERS	Epson LQ / IBM / Diablo
SP	SPACE	Diablo
VT	VERTICAL TAB	Epson LQ / IBM / Diablo

# In Sequence by Function

Function	ASCII Code	Emulation(s)
Absolute move to print line	ESC VT	Diablo
Assign character table	ESC ( t	Epson LQ
Auto justification	ESC a n	Epson LQ / Diablo
Backspace	BS	Epson LQ / IBM / Diablo
Bell	BEL	Diablo
Cancel code	CAN	Epson LQ / IBM
Carriage return	CR	Epson LQ / IBM
Carriage return	CR	Diablo
Character definition	ESC & m n1 n2 d0 d1 d2 <DLL data>	Epson LQ
Copies from CG to ram CG	ESC : NUL n NUL	Epson LQ / Diablo
Cut-sheet feeder control	ESC EM n	Epson LQ / IBM
Disable paper end sensor	ESC 8	Epson/IBM
Disable paper-out detector	ESC 8	Diablo
DLL font select	ESC % n	Epson LQ / Diablo
Double density graphics	ESC L n1 n2 <graphics data>	Epson LQ / IBM / Diablo
Enable paper end sensor	ESC 9	Epson/IBM
Enable upper ASCII control codes	ESC 7	Epson LQ / IBM / Diablo
End automatic underscoring	ESC R	Diablo
End bold/shadow printing	ESC &	Diablo
Enter/exit bit image graphics	ESC * m n1 n2 <graphics data>	Epson LQ / IBM XL24 AGM / Diablo
Execute absolute horizontal dot position	ESC \$ n1 n2	Epson LQ / Diablo
Execute absolute horizontal position	ESC HT n1	Diablo
Execute absolute horizontal position	ESC z n1 n2 n3	Diablo
Execute relative dot position	ESC \ n1 n2	Epson LQ / Diablo
Fine line feed (n/180 inch)	ESC J n	Epson LQ / IBM PPR/IBM XL24
Fine line feed (n/360 inch)	ESC ] n	Epson LQ / Diablo

<b>Function</b>	<b>ASCII Code</b>	<b>Emulation(s)</b>
Fine line feed (n/360 inch)	ESC % 4 n	IBM
Foreign character set select	ESC R n	Epson LQ
Form feed	FF	Epson LQ / IBM / Diablo
Form length set by inches	ESC C NUL n	Epson LQ / IBM
Form length set by lines	ESC C n	Epson LQ / IBM
Graphics resolution	ESC [ g n1 n2 m data	IBM PPR
Half-line feed	ESC U	Diablo
Horizontal tab	HT	Epson LQ / IBM / Diablo
Horizontal tab set	ESC D n1 n2 ... nj nk NUL	Epson LQ / IBM
Ignore	DEL	Diablo
Left margin set	ESC I n	Epson LQ / Diablo
Line feed	LF	Epson LQ / IBM / Diablo
Load dll character	ESC = n1 n2 ... <data>	IBM
Move right relative dot position	ESC d n1 n2	IBM
One character data delete	DEL	Epson LQ
One line unidirectional printing	ESC <	Epson LQ / Diablo
Overscore set/reset	ESC _ n	IBM / Diablo
Perform n/360-inch LF	ESC   5 1 0 n	Epson LQ
Perform sheet feeder operation	ESC EM	Diablo
Print character with code below 20	HEX GS	Diablo
Print continuously from All Characters Chart	ESC \ n1 n2	IBM
Print mode select	ESC ! n	Epson LQ / Diablo
Print mode select	ESC I n	IBM
Print one character from All Characters Chart	ESC *	IBM
Print suppress	ESC Q n	IBM
Printer initialization	ESC @	Epson LQ
Printer initialization	FS @	Epson LQ
Quasi-double density graphics	ESC Y n1 n2 <graphics data>	Epson LQ / IBM / Diablo

<b>Function</b>	<b>ASCII Code</b>	<b>Emulation(s)</b>
Reassign alternate graphics codeS	ESC ? m n	Epson LQ / Diablo
Relative mode inline backward	ESC e	IBM
Reset 8 bit mode	ESC #	Epson LQ / Diablo
Reset compressed character pitch	DC2	Epson LQ
Reset emphasized print mode	ESC F	Epson LQ / IBM / Diablo
Reset enhanced/double strike print mode	ESC H	Epson LQ / IBM / Diablo
Reset immediate double width characters	DC4	Epson LQ / IBM
Reset italic characters	ESC 5	Epson LQ / Diablo
Reset italics characters	ESC % H	IBM
Reset perforation auto skip	ESC 0	Epson LQ / IBM
Reset print suppress mode	DC1	Epson LQ / IBM
Reset printer	ESC CR P	Diablo
Reset super/subscript	ESC T	Epson LQ / IBM
Reset tab settings to power-on default values	ESC R	IBM
Reset top margin	ESC C	Diablo
Reverse half-line feed	ESC D	Diablo
Reverse line feed	ESC j n	Epson LQ / Diablo
Reverse line feed	ESC ]	IBM
Reverse line feed	ESC LF	Diablo
Right margin set	ESC Q n	Epson LQ
Score select	ESC L - Ln Hn P1 P2	IBM
Select 7/72 line spacing	ESC 1 n	Diablo
Select aspect ratio	ESC n	IBM
Select bin	ESC @ T n	Diablo
Select Character Set II	ESC 6	Epson LQ / IBM / Diablo
Select character style	ESC q n	Epson LQ / IBM / Diablo
Select character table	ESC t n	Epson LQ / Diablo
Select character table	FS I n	Epson LQ

<b>Function</b>	<b>ASCII Code</b>	<b>Emulation(s)</b>
Select code page	ESC [ T	IBM
Select eject direction	ESC % T n	Epson LQ / IBM
Select eject direction	ESC   1 1 1 n	Epson LQ
Select emulation mode	ESC { n	Epson LQ / IBM / Diablo
Select head gap	ESC   10H 2 0 n1 n2	Epson LQ
Select international character set	ESC ! n	IBM
Select paper path	ESC   12H 2 0 1 n	Epson LQ
Select type styles	ESC k n	Epson LQ / IBM / Diablo
Select UTL/LQ print quality	ESC x n	Epson LQ / Diablo
Select vertical tab channel	ESC / n	Epson LQ / Diablo
Set 1/6 inch line spacing	ESC 2	Epson LQ / Diablo
Set 1/8 inch fixed line spacing	ESC Ø	Epson LQ / IBM
Set 10 cpi	DC2	IBM
Set 12 cpi	ESC :	IBM
Set 15 character per inch	ESC g	Epson LQ / IBM / Diablo
Set 20 cpi	ESC SI	IBM
Set 7/72 inch fixed line spacing	ESC 1	IBM
Set bit 7 code to 0	ESC =	Epson LQ / Diablo
Set bit 7 code to 1	ESC >	Epson LQ
Set character cell size	ESC @ Z n	Diablo
Set character pitch	ESC US n	Diablo
Set character spacing	ESC SP n	Epson LQ / Diablo
Set compressed character pitch	ESC SI	Epson LQ / IBM / Diablo
Set compressed character pitch	SI	Epson LQ / IBM / Diablo
Set double height character	FS V n	Epson LQ
Set double width or expanded characters	ESC W n	Epson LQ / IBM
Set double width or expanded characters	FS E n	Epson LQ

<b>Function</b>	<b>ASCII Code</b>	<b>Emulation(s)</b>
Set elite character pitch (12 cpi)	ESC M	Epson LQ / Diablo
Set emphasized print mode	ESC E	Epson LQ / IBM
Set emulation	ESC @ E n	Diablo
Set enhanced/double strike print mode	ESC G	Epson LQ / IBM
Set font	ESC @ F n	Diablo
Set forward line spacing	FS F	Epson LQ
Set hex-density graphics	FS Z n1 n2	Epson LQ
Set immediate double width characters	ESC S0	Epson LQ / Diablo
Set immediate double width characters	SO	Epson LQ / IBM / Diablo
Set italic characters	ESC 4	Epson LQ / Diablo
Set italics character	ESC % G	IBM
Set left margin	ESC 9	Diablo
Set left/right margin	ESC X n1 n2	IBM
Set line per page	ESC FF n	Diablo
Set line spacing in 1/120-inch increments	ESC @ A	Diablo
Set line spacing in 1/48-inch increments	ESC RS	Diablo
Set n/180 inch line spacing	ESC 3 n	Epson LQ / IBM PPR/IBM XL24/Diablo
Set n/360 inch fine line spacing	ESC [ n	Epson LQ
Set n/360 inch line spacing	ESC % 8 n	IBM
Set n/360 inch line spacing	FS 3 n	Epson LQ
Set n/360 inch line spacing	ESC + n	Epson
Set n/60 inch line spacing	ESC A n	Epson LQ / IBM PPR/IBM XL24/Diablo
Set NLQ mode	ESC w a	Diablo
Set perforation auto skip	ESC N n	Epson LQ / IBM / Diablo
Set pica character pitch (10 cpi)	ESC P	Epson LQ / Diablo

<b>Function</b>	<b>ASCII Code</b>	<b>Emulation(s)</b>
Set print quality (speed)	ESC @ P n	Diablo
Set print suppress	DC3	Epson LQ
Set quadruple density graphics	ESC Z n1 <graphics data>	Epson LQ / IBM / Diablo
Set reverse line spacing	FS R	Epson LQ
Set subscripts/superscript	ESC S n	Epson LQ / IBM / Diablo
Set top margin	ESC T	Diablo
Set vertical format unit (VFU)	ESC b n m1 m2 ... mk NUL	Epson LQ
Set vertical tab stops	ESC B n1 n2 ... nk NUL	Epson LQ / IBM / Diablo
Set vertical units	ESC [ \ 4 0 0 0 n1 n2	IBM
Set/reset automatic line feed	ESC 5 n	IBM
Set/reset double height characters	ESC US n	Epson LQ
Set/reset double height characters	ESC w n	Epson LQ
Set/reset double height characters	ESC [ @ n1 n2 m1 m2 m3 m4	IBM
Set/reset half speed printing	ESC s n	Epson LQ / Diablo
Set/reset proportional spacing	ESC p n	Epson LQ / Diablo
Set/reset proportional spacing	ESC P n	IBM
Set/reset underlining	ESC - n	Epson LQ / IBM / Diablo
Set/reset unidirectional printing	ESC U n	Epson LQ / IBM
Single density graphics	ESC K n1 n2 <graphics data>	Epson LQ / IBM / Diablo
Software I-Prime	ESC } NUL	Epson LQ / IBM / Diablo
Space	SP	Diablo
Start automatic underscoring	ESC E	Diablo
Start bold printing	ESC O	Diablo
Start line spacing	ESC 2	IBM
Start shadow printing	ESC W	Diablo
Start/end double-high printing	ESC @ H n	Diablo

<b>Function</b>	<b>ASCII Code</b>	<b>Emulation(s)</b>
Start/end double-wide printing	ESC @ W n	Diablo
Start/end super/subscripting	ESC @ V n	Diablo
Stop printing	ESC j	IBM
Top of Form set	ESC 4	IBM
Vertical tab	VT	Epson LQ / IBM / Diablo



# Specifications

*Specifications subject to change without notice.*

## Print Method

- Impact dot matrix

## Printhead

- 24-pin s, 0.2 mm diameter
- Thermal protection

## Emulations

- Epson LQ
- IBM Proprinter
- IBM AGM
- Diablo

## Interfaces (Standard)

- Centronics Parallel
- USB

## Receive Buffer Size

- Selectable 0 or 128 Kbytes

## Throughput

# of parts	Speed (approximation)
1 to 2	10 inches / second 254 mm / second
3 to 6	7 inches / second 177.8 mm / second
7 or more	6 inches / second 152.4 mm / second

## Print Speed

- Print speed varies according to the paper thickness/number of copies, font size, and print quality.

<b>Pitch</b>	<b>Thickness <sup>a</sup></b>	<b>High Quality Print</b>	<b>High Impact Print</b>	<b>High Speed Print</b>
Pica Draft 10 CPI	1 or 2	360	360 (2-pass)	360
	3 or 4	324	324 (2-pass)	324
	5 or 6	288	288 (2-pass)	288
	7 or more	252	252(2-pass)	252
Pica LQ <sup>b</sup> 10 CPI	1 or 2	120	120 (2-pass)	240
	3 or 4	108	108 (2-pass)	216
	5 or 6	96	96 (2-pass)	192
	7 or more	84	84 (2-pass)	168
Elite Draft (12 CPI)	1 or 2	432	432 (2-pass)	432
	3 or 4	388	388 (2-pass)	388
	5 or 6	345	345 (2-pass)	345
	7 or more	302	302 (2-pass)	302
Elite LQ 12 CPI	1 or 2	144	144 (2-pass)	288
	3 or 4	129	129 (2-pass)	259
	5 or 6	115	115 (2-pass)	230
	7 or more	100	100 (2-pass)	201
Condensed Draft 15 CPI	1 or 2	540	540 (2-pass)	540
	3 or 4	486	486 (2-pass)	486
	5 or 6	432	432 (2-pass)	432
	7 or more	378	378 (2-pass)	378
Condensed Draft LQ <sup>b</sup>	1 or 2	180	180 (2-pass)	360
	3 or 4	162	162 (2-pass)	324
	5 or 6	144	144 (2-pass)	288
	7 or more	129	129 (2-pass)	252

a.Thickness = number of layers (pages)

b.LQ = Letter Quality

## Characters per Line (CPL)

Setting	Normal	Wide
10 cpi	136 cpl	68 cpl
12 cpi	163 cpl	81 cpl
15 cpi	204 cpl	102 cpl

## Graphics Resolution

- 360 x 360 dpi maximum (24 dot, hex density)

## Resident Fonts

Print Quality	Available Fonts
Near Letter Quality	Courier, Gothic, Orator, Prestige, Roman, Swiss, Swiss Bold
Utility	Gothic

## Reliability

Parameter	Reliability
Mean Time Between Failures (MTBF)	10.000 hours at 25% duty cycle and 35% page density
Mean Time to Repair (MTTR)	30 minutes
Printhead life	300 million characters
Ribbon Life (on average, 10 cpi utility)	6 million characters

# Print Media Specifications

## Single Sheets

**Note** *Recycled paper can be printed, but please note the following:*

- *Recycled paper tends to leave behind more paper dust, requiring more frequent cleaning of the printer.*
- *Recycled paper is easily affected by humidity and should not be used in humid environments.*

## Width

*Minimum*

- 2.17 inches (55 mm)
- 3.94 inches (100 mm) Auto Align Mode

*Maximum*

- 16.54 inches (420 mm)
- 14.33 inches (364 mm) Auto Align Mode

## Length

*Minimum*

- 2.8 inches (70 mm)

*Maximum*

- 16.54 inches (420 mm)

## Weight

- 14 to 56 lb. US Bond (52 to 210 g/m<sup>2</sup> )

# Print Media Specifications (cont.)

## Individual Multi-Part Forms

**Note** *Recycled paper can be printed, but please note the following:*

- *Recycled paper tends to leave behind more paper dust, requiring more frequent cleaning of the printer.*
- *Recycled paper is easily affected by humidity and should not be used in humid environments.*

### Width

*Minimum*

- 2.17 inches (55 mm)
- 3.94 inches (100 mm) Auto Align Mode

*Maximum*

- 16.54 inches (420 mm)
- 14.33 inches (364 mm) Auto Align Mode

### Length

*Minimum*

- 2.8 inches (70 mm)

*Maximum*

- 16.54 inches (420 mm)

### Thickness

*Normal Mode*

- Up to 6 parts (original + 5)
- Up to 0.014-inch (0.36 mm) thick

*High Impact Mode*

- Up to 8 parts (original + 7)
- Up to 0.019-inch (0.48 mm) thick

# Print Media Specifications (cont.)

## Continuous Single-Part Forms

**Note** *Recycled paper can be printed, but please note the following:*

- *Recycled paper tends to leave behind more paper dust, requiring more frequent cleaning of the printer.*
- *Recycled paper is easily affected by humidity and should not be used in humid environments.*

### Width

- Minimum: 4 inches (101.6 mm)
- Maximum: 16 inches (406.4 mm)

### Weight

- 14 to 34 lb. US Bond (52 to 128 g/m<sup>2</sup> )

## Continuous Multi-Part Forms

### Width

- Minimum: 4 inches (102 mm)
- Maximum: 16 inches (406 mm)

### Thickness

#### *Normal Mode*

- Up to 6 parts (original + 5)
- Up to 0.014-inch (0.36 mm) thick

#### *High Impact Mode*

- Up to 8 parts (original + 7)
- Up to 0.019-inch (0.48 mm) thick

# Print Media Specifications (cont.)

## Envelopes

**Note** *Recycled paper can be printed, but please note the following:*

- *Recycled paper tends to leave behind more paper dust, requiring more frequent cleaning of the printer.*
- *Recycled paper is easily affected by humidity and should not be used in humid environments.*

**Note** *Printing envelopes requires use of the sheet guide (1) instead of the Auto Align mode. See page 54 for information on disabling Auto Align.*

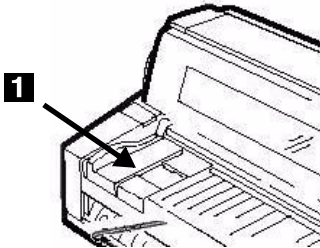

**C6:** 6-3/8 x 4-1/2 inches (162 x 114 mm)

**DL:** 4 -5/16 x 8-11/16 inches (220 x 110 mm)

**COM-10:** 9-1/2 x 4 -1/8 inches (241 x 104.8 mm)

## Printer Dimensions

Width: 24.8 inches (630 mm)

Depth: 23.98 inches (609 mm)

Height: 10.35 inches (263 mm)

## Printer Weight

Printer main body only, 44.1 lb. (20 kg)

## Environmental Requirements

Parameter	Range
<b>Temperature</b>	
Operating	41 to 104°F
	5 to 40°C
Printing	59 to 86°F
	15 to 30°C
Storage	-4 to 140°F
	-20 to +60°C
<b>Humidity</b>	
Operating	30 to 85% RH
Printing	40 to 70% RH
Storage	5 to 95% RH

## Electrical Requirements

- 120 volts ac (+6.0%), 50/60 Hz (±2%)