

OLYMPUS

CAMEDIA

DIGITAL CAMERA

C-5050ZOOM

REFERENCE MANUAL

<Click Here>

CAMERA OPERATION MANUAL

Explanation of digital camera functions and operating instructions.

**DIGITAL CAMERA - PC CONNECTION
OPERATION MANUAL**

Explanation of how to download images between your digital camera and PC.

OLYMPUS

CAMEDIA
DIGITAL CAMERA

C-5050ZOOM

REFERENCE MANUAL

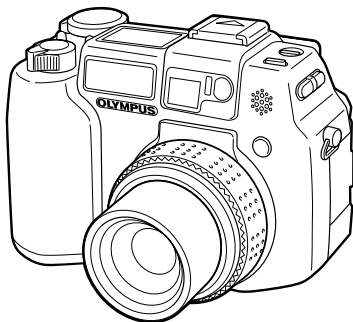

-
- Thank you for purchasing an Olympus digital camera. Before you start to use your new camera, please read these instructions carefully to enjoy optimum performance and a longer service life. Keep this manual in a safe place for future reference.
 - We recommend that you take test shots to get accustomed to your camera before taking important photographs.
 - Screen and camera illustrations shown in this manual were produced during the developmental stages and may differ from those of the actual product.

For customers in North and South America

For customers in USA

Declaration of Conformity

Model Number : C-5050ZOOM

Trade Name : OLYMPUS

Responsible Party : Olympus America Inc.

Address : 2 Corporate Center Drive, Melville, New York
11747-3157 U.S.A.

Telephone Number : 631-844-5000

Tested To Comply With FCC Standards
FOR HOME OR OFFICE USE

This device complies with Part 15 of the FCC rules. Operation is subject to the following two conditions:

- (1) This device may not cause harmful interference.
- (2) This device must accept any interference received, including interference that may cause undesired operation.

For customers in Canada

This Class B digital apparatus meets all requirements of the Canadian Interference-Causing Equipment Regulations.

For customers in Europe



“CE” mark indicates that this product complies with the European requirements for safety, health, environment and customer protection. “CE” mark cameras are intended for sales in Europe.

Trademarks



- IBM is a registered trademark of International Business Machines Corporation.
- Microsoft and Windows are registered trademarks of Microsoft Corporation.
- Macintosh is a trademark of Apple Computer Inc.
- All other company and product names are registered trademarks and/or trademarks of their respective owners.
- The standards for camera file systems referred to in this manual are the “Design Rule for Camera File System/DCF” standards stipulated by the Japan Electronics and Information Technology Industries Association (JEITA).

	Contents	P.4	
	Names of parts	P.10	
Introduction of the camera's functions This section guides you through the basic operations from taking pictures to playing them back.	Getting started	P.20	1
	Shooting and playback basics	P.39	2
	Mode dial and direct button functions	P.59	3
	Using the menus and tabs	P.69	4
Advanced Photography To get that particular shot using various effects or for fine-tuning the settings.	Flash	P.79	5
	Advanced shooting	P.91	6
	Adjusting the image quality and exposure	P.125	7
For playing back and arranging pictures	Playback	P.147	8
Settings that make the camera easier to operate.	Useful functions	P.164	9
Printing pictures	Print setting	P.195	10
Troubleshooting and other information	Miscellaneous	P.205	11

Contents





INDEX	3
Contents	4
Names of parts	10
Camera	10
Control panel indications	13
Monitor indications	15
Memory gauge	18
Battery check	18
How to use this manual	19

1 Getting started 20









Attaching the strap	20
Loading the batteries	21
Selecting optional batteries or an AC adapter	23
Inserting a card	25
Card basics	25
Ejecting the card	27
Switching cards	29
Power on/off	31
Startup/Shutdown screen	32
If the card is not recognized (card check)	33
Selecting a language 	34
Setting the date and time 	36
Adjusting the viewfinder	38

2 Shooting and playback basics 39

Holding the camera	39
Taking still pictures	40
Taking still pictures using the viewfinder	40
Taking still pictures using the monitor	42
Comparison of the viewfinder & monitor	45
If correct focus cannot be obtained	46

Determine the position of the subject after focusing (Focus Lock)	46
Subjects that are difficult to focus on	47
Recording movies 	48
Zoom	50
Using the optical zoom	50
Using the digital zoom	51
Viewing still pictures 	53
Quick View	54
Viewing movies 	55
Protecting pictures 	57
Erasing pictures (Single-frame erase) 	58

3 Mode dial and direct button functions **59**



Mode dial	59
Setting-related modes 	59
Situation-related modes      	61
Playback mode 	62
Direct Buttons	63
Direct buttons and the jog dial	63
Flow of direct button operations	64
Direct button functions	65

4 Using the menus and tabs **69**











About the menus	69
How to use the menus	70
Shortcut menus	72
Mode Menu	74



5 Flash **79**

Flash shooting	79
--------------------------	----





Using the slow synchronization flash  SLOW	84
Flash intensity control 	85
External flash (optional).	86
Using the FL-40 external flash	86
Using commercially available external flashes	88
Compatible commercially available external flashes.	89
Using a slave flash mode	90

6 Advanced shooting 91



Aperture priority shooting A	91
Shutter priority shooting S	92
Manual shooting M	93
Using My Mode 	95
Focusing applications	96
AF MODE - Changing the focus range	96
FULLTIME AF - A reliable time-saving way to focus.	97
Changing the position of the AF target mark.	98
AF illuminator	99
Manual focus.	100
Metering  ,  ^{MULTI}	102
Spot metering	102
Multi-metering	103
AE Lock - Locking the exposure AEL	105
Macro mode shooting 	107
Super macro mode shooting  ^s	108
Self-timer shooting 	109
Remote control shooting 	110
Sequential shooting HI  ,  , AF  , BKT	112
High speed sequential shooting, sequential shooting and AF sequential shooting.	112
Auto bracketing	113
Panorama shooting	116
Taking two-in-one pictures 2 IN 1	119





FUNCTION - Adding special effects to pictures	121
Recording sound with still pictures 	122
Recording sound with movies 	124

7 Adjusting the image quality and exposure 125

Record mode 	125
Selecting a record mode	127
3:2 Resolution	129
ENLARGE SIZE	129
RAW Data	129
ISO sensitivity	130
Exposure compensation 	131
White balance WB	133
Auto white balance	133
Preset 1 white balance	134
Preset 2 white balance	134
Custom white balance	135
One-touch white balance 	136
White balance adjustment 	138
Sharpness	139
Contrast	140
Saturation	141
Scene modes	142
Noise reduction	142
Histogram display 	144





8 Playback 147

Close-up playback 	147
Index display 	148
Selecting the number of pictures	149
Slideshow 	150
Playback on a TV	151

Picture rotation 	152
Recording sound 	153
Editing still pictures	154
Resizing 	154
Trimming 	155
RAW editing	156
Editing movies	158
Creating an index	158
Editing a movie	160
Copying pictures	162
All-frame erase 	163





9 Useful functions

164

All Reset - Saving the camera's settings	164
Custom button 	166
Setting the custom button	167
Using the custom button	168
Shortcut	169
Setting the shortcut menu	170
Using the shortcut menu	171
MY MODE SETUP 	172
Formatting cards 	175
Information display INFO	177
Dual control panel display	178
Monitor brightness adjustment 	180
Rec View	181
Beep sound adjustment 	182
Button operation beep BEEP	183
Shutter sound	184
Playback volume	185
Power on/off display setting	186
Screen setup	187
File name	189

Pixel mapping	190
Measurement units m/ft	191
Video output selection	192
Initializing the settings	193



10 Print setting 195

How to print pictures 	195
All-frame reservation 	197
Single-frame reservation 	199
Canceling reservations	201
Trimming 	202
Resetting print reservation data 	204

11 Miscellaneous 205

Error codes	205
Troubleshooting	207
List of menus	213
List of factory default settings	218
List of items by shooting mode	221
Camera maintenance	224
Specifications	225
Glossary of terms	227
index	231

Indications used in this manual

 Note	Important information on factors which may lead to a malfunction or operational problems. Also warns of operations that should be absolutely avoided.
	Useful information and hints that will help you get the most out of your camera.
	Reference pages describing details or associated information.

Names of parts

Camera

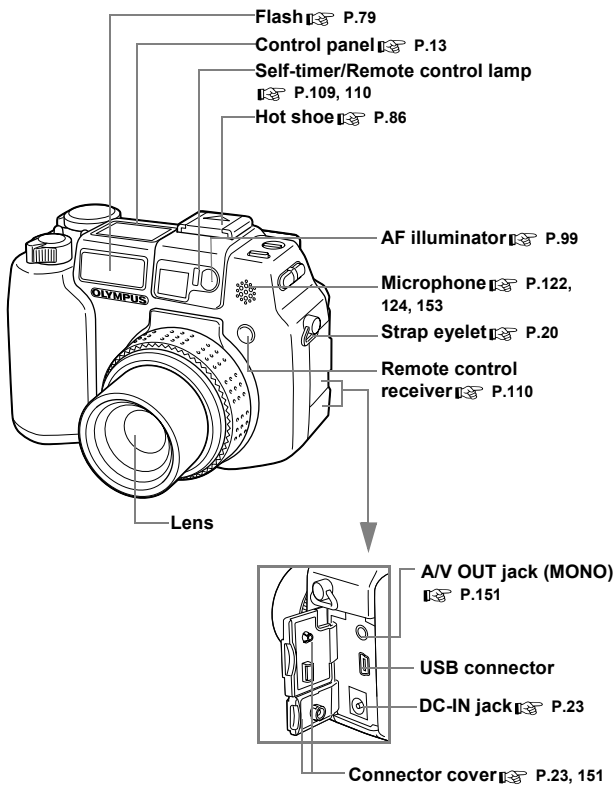

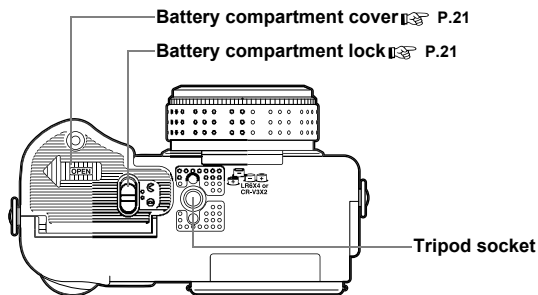
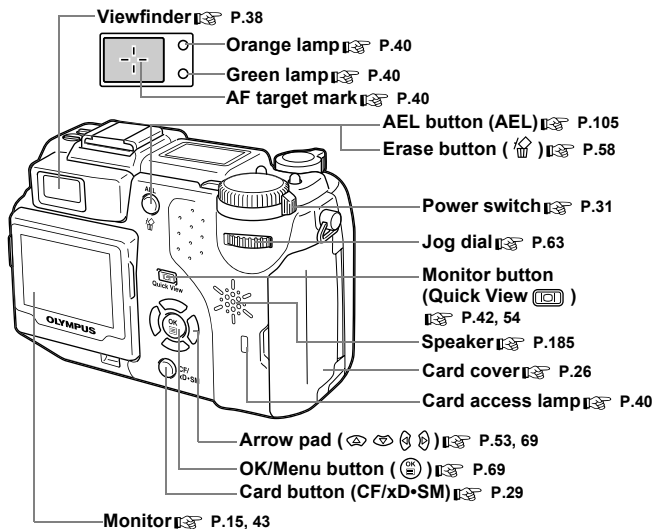

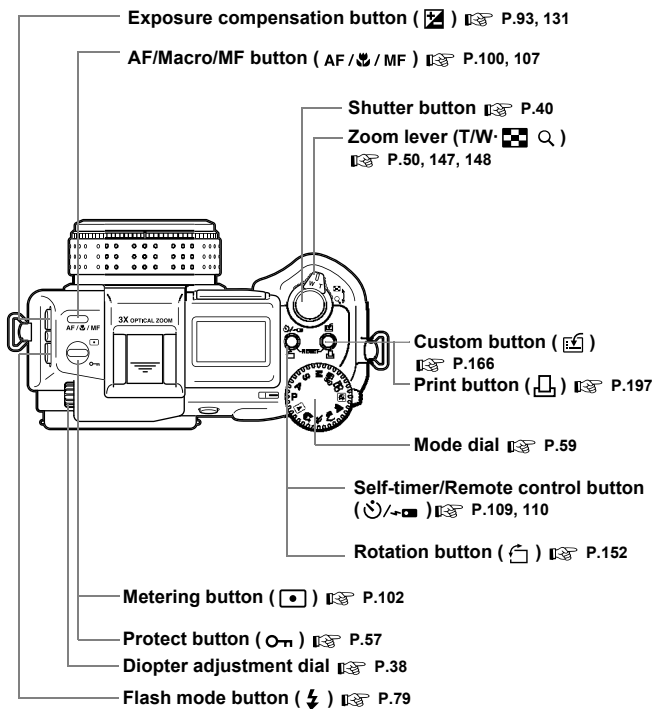

Control panel indications

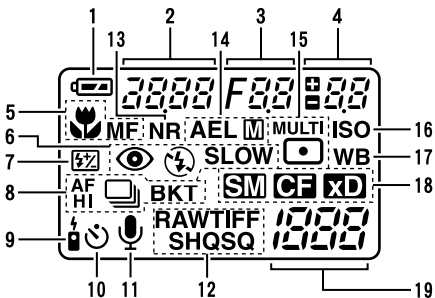

	Items	Indications	Ref. Page
1	Battery check		P.18
2	Shutter speed	2000 (1/2000 sec.), 2.5"	P.92
3	Aperture value	F1.8	P.91
4	Exposure compensation Flash intensity control	+2.0, +1.0, 0.0, -1.0, -2.0	P.131 P.85
5	Macro mode Manual focus Super macro mode Super macro MF mode	(Lights) MF (Lights) (Blinks) MF (Blinks)	P.107 P.100 P.108 P.108
6	Flash mode	, , , SLOW , SLOW	P.79
7	Flash intensity control		P.85
8	Sequential shooting mode	HI , , AF , BKT	P.112
9	Remote control		P.110
10	Self-timer		P.109
11	Sound record		P.122, 124

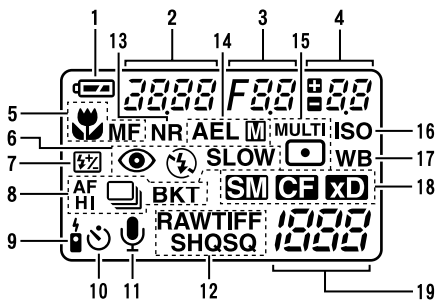







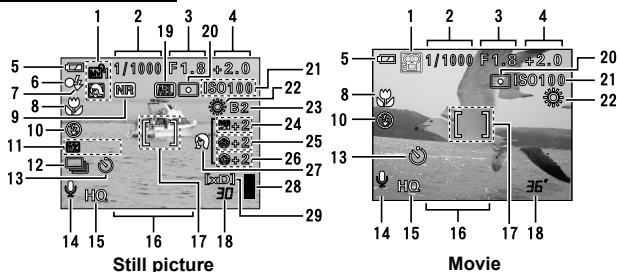

























	Items	Indications	Ref. Page
12	Record mode	RAW, TIFF, SHQ, HQ, SQ (SQ1, SQ2)	P.125
13	Noise reduction	NR	P.142
14	AE lock AE memory	AEL AEL M	P.105 P.106
15	Metering	, MULTI	P.102
16	ISO	ISO	P.130
17	White balance	WB	P.133
18	Selected card	xD , SM , CF	P.29
19	Number of storable still pictures/Seconds remaining Error code	30 -E-	P.48, 126 P.205

Monitor indications

● Shooting mode



	Items	Indications	Ref. Page
1	Shooting mode	P , A , S , M ,  ,  ,  ,  ,  ,  ,  ,  MF	P.59
2	Shutter speed	16 – 1/2000	P.92
3	Aperture value	F1.8 – F8.0	P.91
4	Exposure compensation Exposure differential	-2.0 – +2.0 -3.0 – +3.0	P.131 P.93
5	Battery check	 , 	P.18
6	Green lamp		P.42
7	Flash stand-by/Camera movement warning Flash charge	 (Lights)  (Blinks)	P.80
8	Macro mode Super macro mode Manual focus	  MF	P.107 P.108 P.100
9	Noise reduction	NR	P.142
10	Flash mode	 ,  ,  SLOW 1,  SLOW 2,  SLOW	P.79
11	Flash intensity control	 -2.0 – +2.0	P.85

	Items	Indications	Ref. Page
12	Drive		P.112
13	Self-timer Remote control		P.109 P.110
14	Sound record		P.122, 124, 153
15	Record mode	RAW, TIFF, SHQ, HQ, SQ1, SQ2	P.125
16	Resolution	2560 × 1920, 2560 × 1696, 1280 × 960, 640 × 480, 320 × 240	P.126
17	AF target mark	[]	P.42
18	Number of storable still pictures Seconds remaining	30 36"	P.126 P.48
19	AE lock AE memory		P.105
20	Spot metering		P.102
21	ISO	ISO64, ISO100, ISO200, ISO400	P.130
22	White balance		P.133
23	White balance compensation	B1 – B7, R1 – R7	P.138
24	Saturation	 -5 – +5	P.141
25	Sharpness	 -5 – +5	P.139
26	Contrast	 -5 – +5	P.140
27	Scene modes		P.142
28	Memory gauge		P.18
29	Selected card	[xD], [SM], [CF]	P.29

● Playback mode

INFO setting allows you to select how much information to display on the screen. Screens with the Information display set to ON are shown below.

☞ "Information display" (P.177)

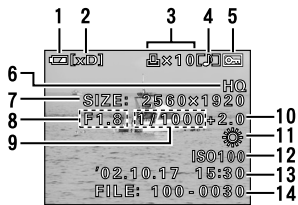

Still picture

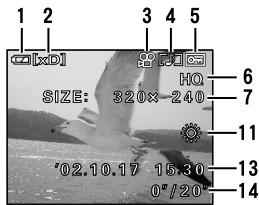

Movie (during playback)

	Items	Indications	Ref. Page
1	Battery check		P.18
2	Selected card	[xD], [SM], [CF]	P.29
3	Print reservation, Number of prints Movie	x 10 	P.197 P.55
4	Sound record		P.123
5	Protect		P.57
6	Record mode	RAW, TIFF, SHQ, HQ, SQ1, SQ2	P.125
7	Resolution	2560 × 1920, 2560 × 1696, 1280 × 960, 640 × 480, 320 × 240	P.126
8	Aperture value	F1.8 – F8.0	P.91
9	Shutter speed	16 – 1/2000	P.92
10	Exposure compensation	-2.0 – +2.0	P.131
11	White balance	WB AUTO, , , , , , , , , AWB, CWB	P.133
12	ISO	ISO64, ISO100, ISO200, ISO400	P.130
13	Date and time	'02.10.17 15:30	P.36
14	File number Playing time/total recording time	FILE : 100 – 0030 0" / 20"	P.189



Note

- The indications that appear on a movie picture that has been selected and displayed from the index display are different from those that appear when the movie picture is displayed using the movie playback function.

● Memory gauge

The memory gauge lights up when you take a still picture. When the gauge is lit, the camera is saving a picture to the card. The memory gauge indication changes as shown below depending on the shooting status. The indication is not displayed during movie recording.

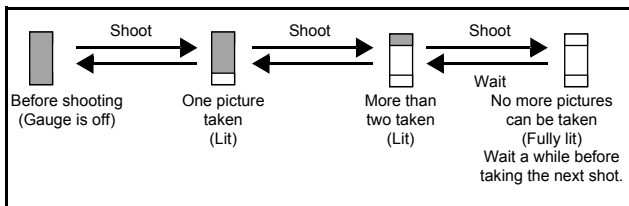

● Battery check

If the remaining battery power is low, the battery check indication on the control panel and monitor changes as follows when the camera is turned on or while the camera is in use.

Battery check	Control panel	Monitor	Status
	Lights	Lights (green) (Goes off after a while)	Remaining power level: high
	Blinks	Blinks (red)	Remaining power level: low Replace with new batteries.
No indication	The green lamp and orange lamp at the side of the viewfinder blink. (The control panel turns off automatically.)		Remaining power level: exhausted Replace with new batteries.

How to use this manual

Set the mode dial to any of the marks shown here.

Flash intensity control



You can adjust the amount of light emitted by the flash. In some situations, you may get better results by adjusting the light emission. Examples include small subjects, distant backgrounds, or situations when increased contrast is desired. You can adjust the brightness in the range of ± 2.0 in $1/3$ EV steps.

Mode dial → P A S M

- 1 Adjust the brightness by turning the jog dial while holding down \downarrow and $\left[\text{Flash} \right]$ at the same time.

- The exposure value is displayed on the control panel while the flash intensity control function is set.



Turning to the left decreases light emission in steps of $1/3$ EV.



Turning to the right increases light emission in steps of $1/3$ EV.

(EV : Expo)

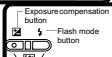

The buttons for the function and their location are clearly illustrated.

This shows jog dial operations.

Follow the arrows to perform menu operations. For details on operating procedures, see "How to use the menus" (P.70).

Sharpness

This function adjusts the sharpness of the image.

Mode dial → P A S M

- 1 In the top menu, select **MODE MENU** → **PICTURE** → **SHARPNESS**, and press $\left[\text{OK} \right]$.
E30 "How to use the menus" (P.xx)



- 2 Press $\left[\text{Left Arrow} \right]$ to adjust the sharpness between +5 and -5.

- To increase the sharpness (+): Press $\left[\text{Left Arrow} \right]$. The image colours are emphasized, making the image appear sharper.



This represents the arrow pad. Only arrows applicable to the operation are shown.

- This sample page is only for your reference. It may differ from the actual page in this manual.

1 Getting started

Attaching the strap

- 1** Pass the lens cap string through the hole in the lens cap, then pass the other end through the loop and pull tight.

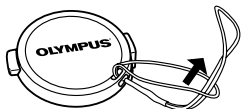

- 2** Pull the ends of the strap out of the stopper and ring.

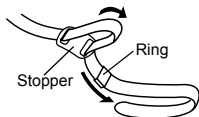

- 3** Thread one end of the strap (A) through the string loop (attached to the lens cap in step 1). Then thread it through the strap eyelet on the camera.

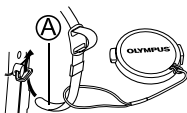

- 4** Thread the end of the strap back through the ring and stopper as indicated by the arrows. Adjust the strap to the desired length.

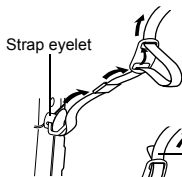

- 5** Pull the strap through the stopper (B) to make sure it is fastened securely.

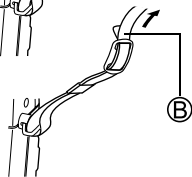

- 6** Attach the strap to the other eyelet following steps 3 to 5.



Note

- Be careful with the strap when you carry the camera, as it can easily catch on stray objects, causing injury or damage.
- Attach the strap correctly as shown above so that the camera does not fall off. If the strap is attached incorrectly and the camera falls off, Olympus is not responsible for any damages.

Loading the batteries

This camera uses two CR-V3 lithium battery packs or four AA (R6) NiMH batteries, NiCd batteries, alkaline batteries or lithium batteries.

Important

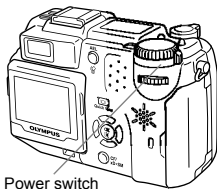
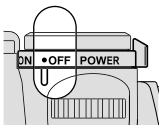

- CR-V3 lithium batteries cannot be recharged.
- Do not peel off the label from a CR-V3 lithium battery pack.

- 1 Make sure the power switch is set to OFF.**

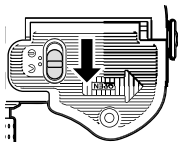

- 2 Slide the battery compartment lock from  to .**



- 3 Place your finger on the  mark and slide the battery compartment cover in the direction of , then lift in the direction of .**

- Use the ball of your finger to slide the cover. Do not use your fingernail as this could result in injury.

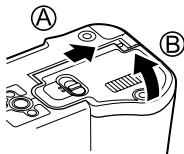

1

Getting started

4 Insert the batteries, making sure that they are correctly oriented as shown in the illustration.

When using AA (R6) batteries

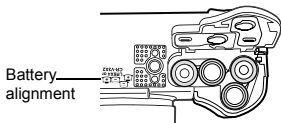

The correct way to insert the AA batteries is indicated on the bottom of the camera.

When using CR-V3 lithium battery packs

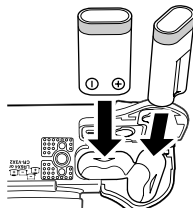

5 Close the battery compartment cover, then press it down (C) and slide it in the direction shown (D).

- Press the center of the cover, as it may be difficult to close properly by pressing the edge.
- Make sure the cover is closed securely.

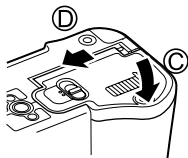

6 Slide the battery compartment lock from (C) to (D).

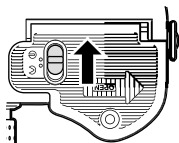

Note

- If the camera is left for about 1 hour with the batteries removed, some of the internal settings may revert to the factory default settings.

Precautions when using batteries

The amount of power consumed varies considerably depending on the operations performed on the digital camera. If you use exhausted batteries or alkaline batteries, the camera may turn off without displaying the battery level warning (P.18).

Selecting optional batteries or an AC adapter

In addition to the batteries provided with the camera, the following types of battery or AC adapter can be used. Choose the power source best suited to the situation.

● **CR-V3 lithium battery packs (Not rechargeable)**

Since the CR-V3 lithium battery pack has a long service life, it is convenient when traveling.

● **NiMH batteries (Rechargeable)**

Olympus NiMH batteries are rechargeable and economical. Their low-temperature resistance makes them a good choice for cold areas.

● **AA (R6) alkaline batteries**

When you need batteries in a hurry, you can use AA (R6) alkaline batteries, which are easy to obtain anywhere. However, the number of pictures that you can take may vary considerably depending on the battery manufacturer, shooting conditions, etc. Turn off the monitor whenever possible to save power.

● **AC adapter**

An optional Olympus CAMEDIA-brand AC adapter allows you to power your digital camera from a common AC wall outlet. Be sure to use the specified AC adapter. An AC adapter is useful for time-consuming tasks such as image downloads.

Use an AC adapter designed to operate on the AC voltage in the area the camera is being used.

Consult your nearest Olympus dealer or Service center for details.

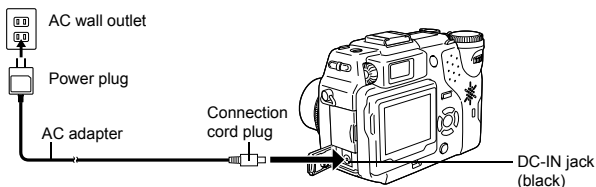



Note

1

Getting started

- Manganese (zinc-carbon) batteries cannot be used.
- If the battery power runs out while the camera is connected to a PC, the image data may be lost or damaged. You are recommended to use the AC adapter when transferring images to a PC. Do not connect or disconnect the AC adapter while the camera is communicating with the PC.
- Do not remove or load the batteries or connect or disconnect the AC adapter while the camera is turned on. Doing so could affect the camera's internal settings or functions.
- The life of battery may vary according to the type of battery, manufacturer, shooting conditions, etc.
- Power is consumed continuously during the conditions described below. This could reduce the number of pictures that can be taken.
 - When the monitor is turned on.
 - When the monitor is in the playback mode for an extended period of time.
 - Repeated zoom adjustments.
 - Repeated auto-focus by depressing the shutter button halfway.
 - When the FULLTIME AF mode is turned on.
 - When the camera is connected to a PC.
- Carefully read the AC adapter's instructions before use.
- When using an AC adapter, power is supplied to the camera by the AC adapter even if batteries are loaded in the camera. The AC adapter does not charge batteries in the camera.

Inserting a card

“Card” in this manual refers to the xD-Picture Card, SmartMedia, Compact Flash and Microdrive. The camera uses the card to record pictures. The xD-Picture Card and SmartMedia use the same slot, as do Compact Flash and Microdrive. Cards used in the same slot cannot be inserted at the same time.

Card basics

The card corresponds to normal camera film for recording the pictures you have taken. Pictures recorded and stored on the card can easily be erased, overwritten, and/or edited on a PC.

The following cards can be used: Read the instructions for the card carefully before use.

xD-Picture Card (provided)

- 16 to 128 MB

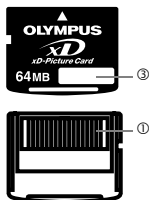

SmartMedia (SM) (optional)

- 4 to 128 MB

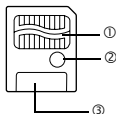

Compact Flash (CF) (optional)

- You can use small flash memory cards and commercially available cards.



Microdrive (optional)

- You can use Microdrive that supports CF+Type II (Compact Flash expansion standard). Microdrive is a compact hard disk drive. Be sure to read the “Precautions for using Microdrive” (P.29).

① Contact area

Comes into contact with the camera’s signal read contacts.

② Write-protect area

Attach the provided write-protect seal when you want to protect your data from accidental erasure or overwriting. xD-Picture Card does not have a write-protect area.

③ Index area

Use the provided index label to indicate the card’s contents.



Note

- 2 MB SmartMedia cannot be used.
- Commercially available 5 V SmartMedia cannot be used.
- 340 MB Microdrive cannot be used.
- This camera may not recognize a non-Olympus card (such as a 3 V (3.3 V) SmartMedia), or a card that was formatted on another device (such as a PC, etc.). Before use, be sure to format the card on this camera. ➡ “Formatting cards” (P.175)

- 1 Make sure the power switch is set to OFF.

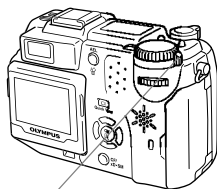
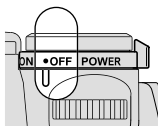

Power switch

- 2 Open the card cover.

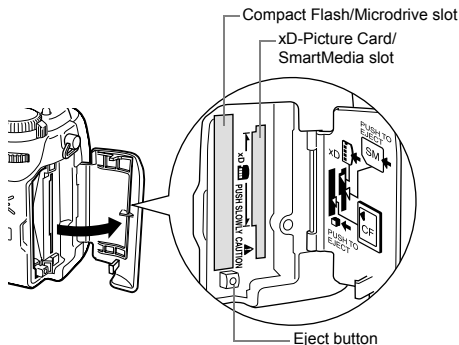

Note

- The xD-Picture Card and SmartMedia use the same slot, as do Compact Flash and Microdrive. Two cards cannot be inserted in the one slot at the same time.

3 Insert a card.

xD-Picture Card

- Hold the card straight and insert it correctly into the xD-Picture Card/SmartMedia slot, as shown.
- An illustration showing the position for inserting the xD-Picture Card is next to the slot.

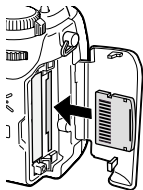

SmartMedia

- Hold the card straight and insert it correctly into the xD-Picture Card/SmartMedia slot, as shown.

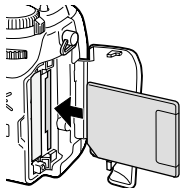

Compact Flash/Microdrive

- Hold the card straight and insert it correctly into the Compact Flash/Microdrive slot.

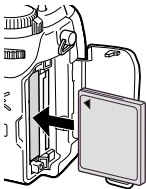

1
Getting started

4 Close the card cover securely until it clicks.

Ejecting the card

xD-Picture Card

- Push the card all the way in to unlock it, then let it return slowly.
The card is ejected a short way and then stops.
Hold the card straight and pull it out.

Note

Releasing your finger quickly after pushing the card all the way in may cause it to eject forcefully out of the slot.

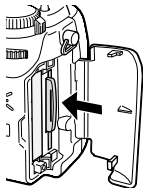

SmartMedia

- Push the card in, then release it. The card will be ejected a short way to enable you to pull it out.

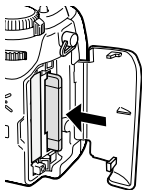

1

Getting started

Compact Flash/Microdrive

- Press the eject button gently and allow it to pop out, then press it again all the way in. The card will be ejected a short way to enable you to pull it out.

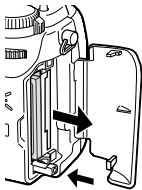

Note

- Never open the card cover, or remove the card or the batteries while the camera is turned on. Doing so could destroy the data stored on the card. Once destroyed, data cannot be restored.

Switching cards

Pictures are recorded on the card displayed on the control panel or monitor. Choose the card you want to record the picture on before taking the picture. The factory default setting is the card inserted in the xD-Picture Card/SmartMedia slot. If only one card is inserted, that card is automatically selected. Card selection can also be made in Playback mode.

1 Press the card button repeatedly to select the card you want to use.

- The indication on the control panel alternates between the two slots.

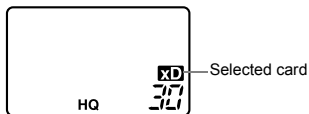

xD : xD-Picture Card
SM : SmartMedia

CF : Compact Flash or Microdrive

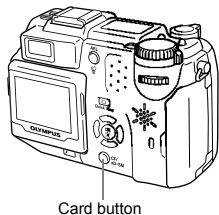

● Precautions for using Microdrive

The following restrictions apply when using Microdrive. Read the instructions provided with your Microdrive.

You are recommended to use an xD-Picture Card, SmartMedia or Compact Flash card when taking important pictures.

Operating environment

Microdrive is a compact hard disk drive. As it is a rotating recording medium, it is not as resistant to vibration or impact as the solid recording medium of other cards.

When using Microdrive, be careful not to subject the camera to vibration or impact. (Special care is needed during recording and playback.)

- Do not bang the camera down on the table during recording.
- Be careful not to hit the camera against anything when carrying it on your shoulder.
- Do not use the camera where the ground is likely to vibrate, such as a construction site.
- Do not use the camera in the car while driving along a bumpy road where the camera will be badly shaken.

Precautions regarding Microdrive

- Do not write on the label.
- Do not remove the label.
- Do not stick another label on top of the label.
- It is advisable to keep Microdrive in its case for storage or transportation.
- Microdrive may become hot if used for an extended period of time. Care should be taken when handling Microdrive.
- Do not take close to where there is strong magnetism.
- Do not apply strong pressure to the cover.

Camera operations

Using Microdrive may shorten the life of the batteries. To reduce consumption of the batteries, observe the following.

- Whenever possible, refrain from using the monitor during shooting.
- Unless there is a particular need, do not use an xD-Picture Card or SmartMedia at the same time as Microdrive. Remove the xD-Picture Card or SmartMedia when using Microdrive.
- Use large capacity batteries, such as CR-V3 lithium battery packs.
- If nothing happens when the buttons are pressed, remove the batteries, then put them back again.
- If you use Microdrive when the battery power is low, the camera may not turn on.

If CARD ERROR is displayed





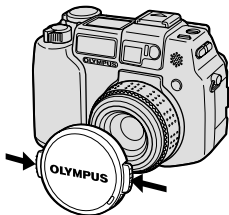

- If no pictures can be recorded or downloaded, run SCANDISK on a PC.
 "Error codes" (P.205)

Power on/off

● When shooting pictures

- 1 Press the tabs on the lens cap as indicated by the arrows and remove the lens cap.



- 2 Turn the mode dial until the mode you want to use is aligned with the red line. Choose from P / A / S / M /  /  /  /  /  /  / .

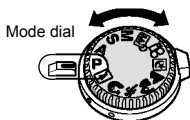

- 3 Turn the power switch so that ON is aligned with the white line.
 - The camera turns on and the lens extends.
 - If the lens cap has not been removed, the warning beep sounds and the camera does not turn on. Be sure to remove the lens cap first.

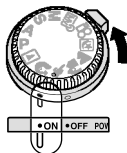
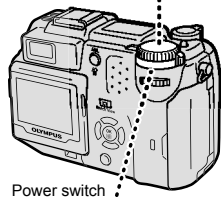

- 4 To turn the power off, turn the power switch so that OFF is aligned with the white line.



● When playing back pictures

- 1 Turn the mode dial until  is aligned with the red line.
- 2 Turn the power switch so that ON is aligned with the white line.
 - The monitor turns on.
- 3 To turn the power off, turn the power switch so that OFF is aligned with the white line.
 - The monitor also turns off.

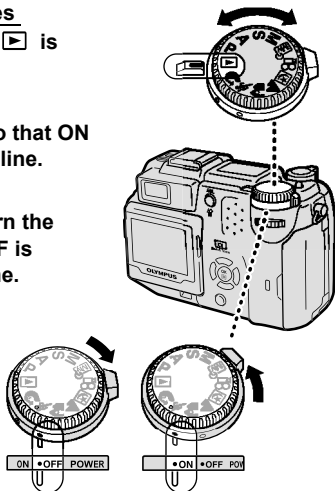

TIPS

- To save battery power, the camera automatically enters the sleep mode after about 3 minutes of non-operation. The camera activates again as soon as you touch the shutter button or zoom lever.
- To save power, the camera turns off automatically and retracts the lens after about 4 hours of non-operation. To resume operation, turn the camera on again.

Startup/Shutdown screen

You can register a picture that will be displayed on the monitor and sound that will be played when turning the camera on or off. (P.186) You can also adjust the volume of the sound. (P.185)

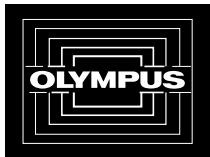

Startup/Shutdown screen (Factory default setting)















If the card is not recognized (card check)

When the power is turned on, the camera checks the card automatically. If there is no card in the camera or a card that is not supported by this camera is inserted, the following screen is displayed.



Note

- All data stored on the card is erased when the card is formatted.

Control panel	Monitor indication	Corrective action
		There is no card in the camera or the card is not inserted properly. → Insert a card. If a card is already inserted, remove it and insert it again correctly.
		There is a problem with the card. → Use a different card. Insert a new card.
		The card cannot record, play back or erase pictures. Format the card or replace it with a new one. → Press   to select POWER OFF, then press  . Replace it with a new one. → Format the card. Press   to select  FORMAT, then press  to display the confirmation screen. Select YES and press  . Formatting starts. If the card was successfully formatted, the camera is ready to take pictures.

1

Getting started

Selecting a language



You can select a language for on-screen display. This reference manual shows the English on-screen display in the illustrations and explanations. Available languages vary depending on the area where you purchased this camera.

1

Getting started

1 Set the mode dial to **P** and turn the camera on.

- Be sure to remove the lens cap before you turn the camera on.
- You can select the language in all modes.

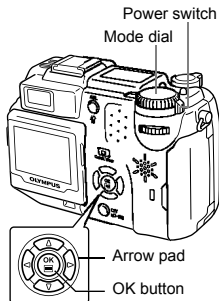

2 Press .

- The top menu is displayed.



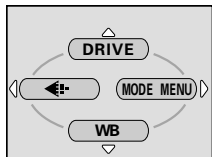

3 Press on the arrow pad to select **MODE MENU**.

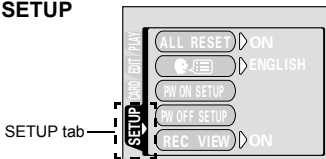

Top menu

4 Press to select the **SETUP** tab, then press .



- 5 Press   to select   , then press  .

- 6 Press   to select a language, then press  .

- 7 Press  again to exit the menu.

- 8 To turn the camera off, set the power switch to OFF.

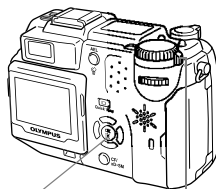
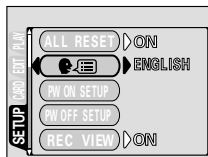

Power switch

Setting the date and time



- 1 Set the mode dial to P and turn the camera on.**
 - Be sure to remove the lens cap before you turn the camera on.
 - You can set the date and time in all modes.

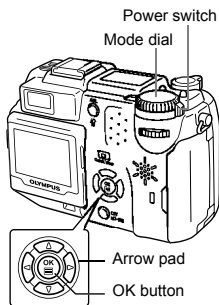

1

Getting started

- 2 Press .**
 - The top menu is displayed.
- 3 Press on the arrow pad to select MODE MENU.**

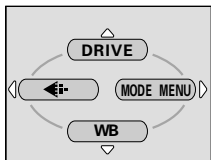

Top menu

- 4 Press to select the SETUP tab, then press .**

SETUP tab

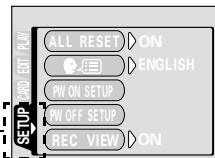

- 5 Press to select , then press .**
 - The green frame moves to the selected item.

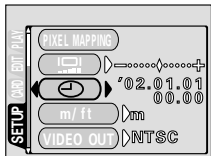

- 6** Press to select one of the following date formats: Y-M-D (Year/Month/Day), M-D-Y (Month/Day/Year), D-M-Y (Day/Month/Year). Then press .

- Move to the year setting.
- The following steps show the procedure used when the date and time settings are set to Y-M-D.

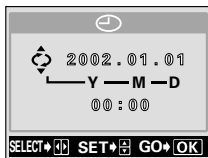

- 7** Press to set the year, then press to move to the month setting.

- To move back to the previous setting, press . The first two digits of the year are fixed.

- 8** Repeat this procedure until the date and time are completely set.

- 9** Press .

- For a more accurate setting, press when the time signal hits 00 seconds. The clock starts when you press the button.

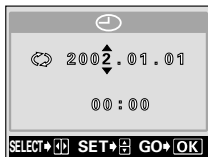

- 10** To turn the camera off, set the power switch to OFF.

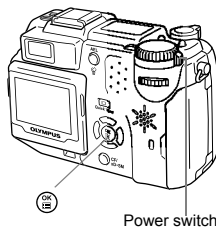

Note

- The current settings are retained even when the power is turned off, unless they are readjusted.
- The date and time settings will be canceled if the camera is left without batteries for approximately 1 hour. The settings will be canceled more quickly if the batteries were only loaded in the camera for a short time before being removed. Before taking important pictures, check that the date and time settings are correct.

1

Getting started

Adjusting the viewfinder

To make the camera easier to use, adjust the viewfinder to match the eyesight (visual acuity) of the person using the camera.

- 1 While looking through the viewfinder, slowly turn the diopter adjustment dial.**

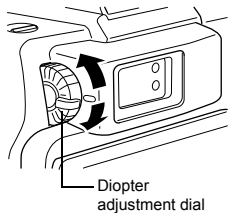

- 2 Turn the dial until the AF target mark can be seen clearly.**

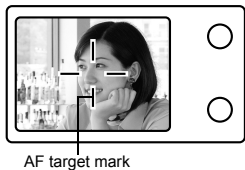

1

Getting started

2 Shooting and playback basics

Holding the camera

Hold the camera firmly with both hands while keeping your elbows at your sides to prevent the camera from moving. When taking pictures in the vertical position, hold the camera so that the flash is at the top.

Keep your fingers and the strap away from the lens and flash.

Horizontal grip

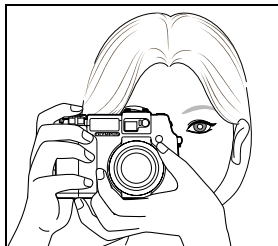

Vertical grip

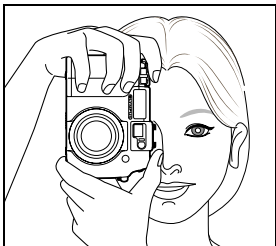

Top view

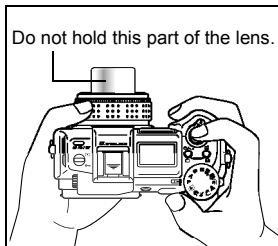

Note

- Clear pictures cannot be obtained if the camera moves as the shutter button is pressed. Hold the camera correctly, and press the shutter button gently.







Taking still pictures

You can take still pictures using either the viewfinder or the monitor.

Taking still pictures using the viewfinder

The camera actually records a wider area than the picture you compose while looking through the viewfinder.



- 1 Set the mode dial to **P A S M**       and turn the camera on.

 "Power on/off" (P.31)

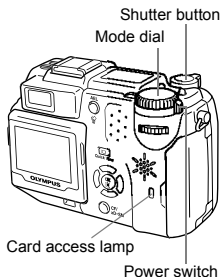

- 2 Position the AF target mark in the viewfinder on the subject.

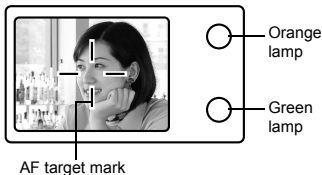

- 3 Press the shutter button gently (halfway) to adjust the focus.

- When the focus and exposure are locked, the green lamp lights.
- If the orange lamp lights, the flash fires automatically.
- The shutter speed and aperture value automatically set by the camera are displayed on the control panel.

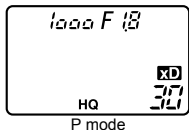

4 Press the shutter button all the way (fully).

- The camera takes the picture.
- The card access lamp blinks while the picture is stored on the card.
- When the green lamp stops blinking, you can take the next picture.

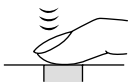

TIPS

The green lamp blinks.

- You are too close to the subject. Take the picture at least 20 cm away from the subject. If you use the super macro mode, you can take pictures as close as 3 cm/1.2" from the subject. (P.108)
- Depending on the subject, the focus and exposure may not be locked. "Subjects that are difficult to focus on" (P.47)

The orange lamp blinks when the shutter button is pressed halfway.

- The flash is charging. Wait until the lamp goes off.

To check the picture you have just taken immediately.

- Set Rec View to ON. "Rec View" (P.181)

To record sound when taking pictures.

- You can record sound when taking still pictures. Set to ON. "Recording sound with still pictures" (P.122) You can also add sound to a picture that has already been taken. "Recording sound" (P.153)

Taking still pictures using the monitor

With the monitor, you can shoot while checking the picture area that the camera actually records. You can also check the shooting status, such as the aperture value and shutter speed.



- 1** Set the mode dial to

P A S M

"Power on/off" (P.31)

- 2** Press to turn the monitor on.

- You can also change the angle of the monitor when taking pictures.

- 3** Position the AF target mark on the subject while looking at the image on the monitor. Decide the composition of the picture.

- 4** Take the picture by following the same procedure as for shooting using the viewfinder.

"Taking still pictures using the viewfinder" (P.40)

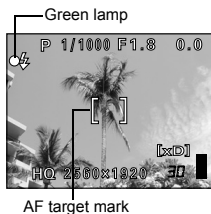
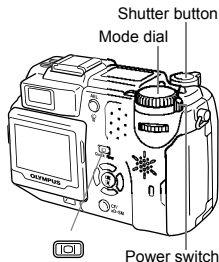

- When the focus is locked by pressing the shutter button halfway, the green lamp on the monitor lights. The AF target mark moves to the focused position. If you cannot focus on the subject, select SPOT for the AF mode and then shoot.

"AF MODE - Changing the focus range" (P.96)

● Changing the angle of the monitor

It is useful to pull the monitor out when taking pictures at an angle where the viewfinder or monitor is hard to see, such as low angle shots.

- 1 Grip the monitor at the position shown and pull the top of the monitor out.**

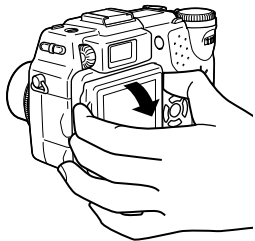

- 2 If you want to use the monitor with it facing upward, pull out the bottom of the monitor as shown and change the angle.**

- The monitor locks into position at the following angles: -20; +20; +45; +90 degrees.
- If you want to take high angle shots, it is useful to use the monitor as shown on the right.

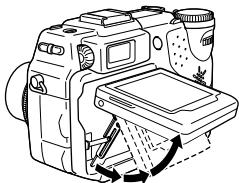
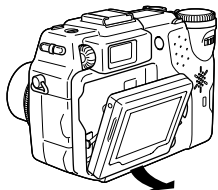

2

Shooting and playback basics



**TIPS****The monitor does not turn on.**

→ If the camera is not used for over 3 minutes, the monitor turns off automatically. Touch the shutter button or zoom lever to turn the monitor on.

Vertical lines on the monitor screen make it hard to see the image.

→ Bright light, such as direct sunlight, may cause vertical lines to appear on the monitor screen. In this case, use the viewfinder.

To check the area the camera is focusing on

→ If you press  while pressing the shutter button halfway, the area you are focusing on is enlarged. Pressing  once more returns the size to normal. This function is not available in the digital zoom range.  "Using the digital zoom" (P.51)



Also see the TIPS on "Taking still pictures using the viewfinder" (P.40).



Note

- Press the shutter button gently using the ball of your finger. If it is pressed hard, the camera may move and pictures may come out blurred.
- Recorded pictures will be saved on the card regardless of whether the camera is turned off or the batteries are replaced or removed.
- Never open the card cover, remove the batteries or disconnect the AC adapter while the card access lamp is blinking. Doing so could destroy stored pictures and prevent storage of pictures you have just taken.
- When taking pictures against strong backlight, the area of the picture in shadow may appear colored.
- When you point the camera lens toward a bright subject, smears (lines like beams of light) may appear on the image in the monitor. This does not affect recorded pictures.

Comparison of the viewfinder & monitor

	Viewfinder	Monitor
Advantages	Camera movement does not occur easily and subjects can be seen clearly even in bright places. Little battery power is used.	You can check the picture area that the camera actually records more accurately.
Disadvantages	When close to a subject, the image in the viewfinder is a little different from the picture that the camera actually records.	Camera movement can occur easily and subjects may be difficult to see in bright/dark places. The monitor uses more battery power than the viewfinder.
Tips	Use the viewfinder for general snapshots (landscape pictures, casual shots, etc.). (Approx. 0.8 m/2.6 ft. to ∞)	Use the monitor when you want to shoot while checking the picture area that the camera actually records, or take pictures when the subject is less than 0.8 m/2.6 ft. away, such as close-up shots of people or flowers (macro shooting).

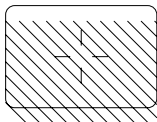

- The camera records a wider area than the image in the viewfinder.
- As you get closer to the subject, the actual image recorded becomes lower than the one in the viewfinder (see left).

If correct focus cannot be obtained

When the subject you want to focus on is not in the center of the frame and you cannot position the AF target mark on it, you can focus the camera on another point at roughly the same distance (focus lock) and take the picture as explained below.

Determine the position of the subject after focusing (Focus Lock)



- 1 Set the mode dial to **P A S M** and turn the camera on.

☞ "Power on/off" (P.31)

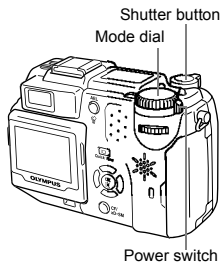

- 2 Position the AF target mark on the subject you want to focus on.

- When shooting a hard-to-focus subject or a fast-moving subject, point the camera at an object about the same distance away as the subject.

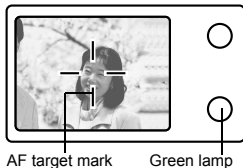

- 3 Press the shutter button halfway until the green lamp lights.

- When the focus and exposure are locked, the green lamp lights.
- If the monitor is turned on, the AF target mark moves to the focused position.
- When the green lamp blinks, the focus and exposure are not locked. Release your finger from the shutter button, re-position your subject and press the shutter button halfway again.

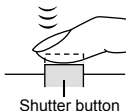

- 4** Keeping the shutter button pressed halfway, recompose your shot.



- 5** Press the shutter button fully.

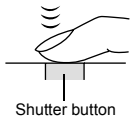

TIPS

The frame in which you focus on a subject is different from the frame in which you lock the exposure.

☞ “AE Lock - Locking the exposure” (P.105)

Subjects that are difficult to focus on

Under certain types of conditions, the auto focus may not work properly. If this happens, focus on an object with high contrast at the same distance as the intended subject (focus lock), recompose your shot and then take the picture. If the subject has no vertical lines, hold the camera vertically and focus the camera using the focus lock function by pressing the shutter button halfway, then return the camera to the horizontal position while keeping the button pressed halfway and take the picture.

If the subject still cannot be focused on, use the manual focus. ☞ “Manual focus” (P.100)

The green lamp blinks.
The subject cannot be brought into focus.

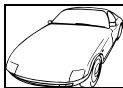

Subject with low contrast



Subject with an extremely bright area in the center of the frame



Subject without vertical lines

The green lamp lights,
but the subject cannot be brought into focus.



Subjects at different distances



Fast-moving subject



The subject to be focused on is not in the center of the frame.



Even if the distance between the camera and the subject changes while you are recording a movie, the FULLTIME AF is set to on to maintain the correct focus and exposure (factory default setting).

Mode dial



- 1 **Set the mode dial to  and turn the camera on.**

 "Power on/off" (P.31)

- The monitor turns on and the available recording time on the card that you are using is displayed.

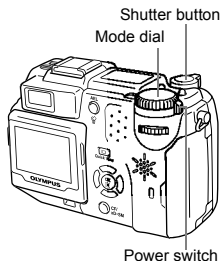

- 2 **Decide the composition while looking at the image on the monitor.**



- 3 **Press the shutter button fully to start recording.**

- The orange lamp on the right of the viewfinder lights.
- During movie recording,  lights red.





Seconds remaining

- 4 **Press the shutter button again to stop recording.**





- The card access lamp blinks while the movie is stored on the card.
- When the remaining recording time has been used up, recording stops automatically.
- When there is space in the card memory, the remaining recording time is displayed, and the camera is ready to shoot.

**TIPS****To record sound with the movie**

→ You can record sound when recording a movie. Set  to ON.
 “Recording sound with movies” (P.124)



Note

- Depending on the card, the remaining recording time may drop rapidly during recording. Try using the card again after formatting it with your camera.  “Formatting cards” (P.175)
- When  is set to ON, the optical zoom cannot be used during movie recording. To use the zoom during recording, set DIGITAL ZOOM to ON.  “Using the digital zoom” (P.51)
- When  is set to ON, the movie is recorded with the focus and exposure that were set when the shutter button was pressed in step 3. Care should be taken as it may be difficult to achieve the correct focus.
- In  mode, the flash, manual focus (MF) cannot be used. In addition, WHITE BOARD and BLACK BOARD cannot be selected in FUNCTION.

Notes for recording movies over a long time

- Recording will continue until the card is full unless stopped by pressing the shutter button.
- A long recorded movie cannot be edited. (P.158)
- If a single movie recording uses up all of the card's memory, create space on the card by deleting the movie or downloading it to a PC.

Zoom

Telephoto and wide-angle shooting are possible at 3x magnification (the optical zoom limit, equivalent to 35 mm – 105 mm on a 35 mm camera). By combining the optical zoom with the digital zoom, zoom magnification can be increased to a maximum of approximately 10x.

Using the optical zoom

Mode dial

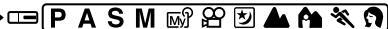

2

Shooting and playback basics

- 1 Set the mode dial to

P A S M      

and turn the camera on.

 "Power on/off" (P.31)

Zoom lever

Mode dial



Power switch

- 2 Turn the zoom lever.

Wide-angle: Turn the zoom lever toward W to zoom out.

Telephoto: Turn the zoom lever toward T to zoom in.



Using the digital zoom



- 1 Set the mode dial to **P A S M** and turn the camera on.

"Power on/off" (P.31)

- 2 Press .

• The top menu is displayed.

- 3 Press to select **MODE MENU**.

- 4 Press to select the **CAMERA** tab, then press .

- 5 Press to select **DIGITAL ZOOM**, then press .

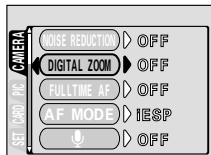
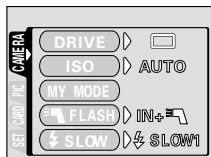
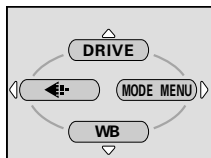
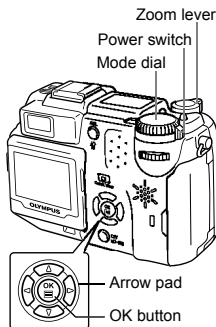

6 Press to select ON, then press .

- Press  again to exit the menu and the subject is displayed on the monitor.

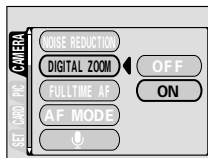

7 Turn the zoom lever toward T.

- The white area of the zoom indicator indicates the optical zoom. If the digital zoom is set to ON, a red area appears on the zoom indicator. When you reach the limit of the optical zoom, the digital zoom is enabled.



The cursor moves up and down on the zoom indicator according to the zoom magnification.

The cursor turns orange when inside the digital zoom field.

2



Note

- In  mode, the maximum digital zoom magnification is 2.5x.
- Pictures taken with the digital zoom may appear grainy.
- Camera movement is likely to occur at higher magnifications. Stabilize the camera with a tripod, etc. to avoid camera movement.
- Turning the monitor off cancels the digital zoom. However, if the digital zoom is set to ON, it will be automatically enabled the next time you turn the monitor on.



Mode dial



- 1 Set the mode dial to  and turn the camera on.

 "Power on/off" (P.31)

- The monitor turns on and displays the last picture taken. (Single-frame playback)

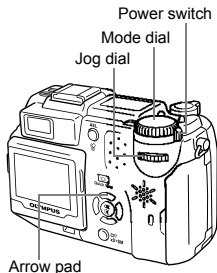

- 2 Use the arrow pad or jog dial to play back other pictures.

- Arrow pad

Jumps to the picture 10 frames back.

Displays the previous picture.

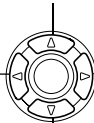

Displays the next picture.

Jumps to the picture 10 frames ahead.

- Jog dial

Displays the previous picture.



Displays the next picture.



Note

- If the camera is not used for over 3 minutes, the monitor turns off automatically. Press  or any button to turn the monitor on.

Quick View

This function lets you play back pictures while the camera is in the shooting mode. This is useful when you want to check shooting results and resume shooting quickly.

Functions available in normal playback mode are also available in Quick View.

Mode dial

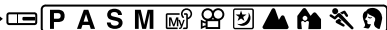

2

Shooting and playback basics

- 1 Press  twice quickly (double-click) while in the shooting mode.

- The camera immediately enters the playback mode and displays the last picture taken. (Single-frame playback)



- 2 Press the shutter button halfway to return to the shooting mode.



Mode dial

- 1 Set the mode dial to and turn the camera on.

"Power on/off" (P.31)

- The monitor turns on.

- 2 Use the arrow pad or jog dial to display the picture with you want to play back.

"Viewing still pictures" (P.53)

- 3 Press .

- The top menu is displayed.

- 4 Press to select MOVIE PLAY.

- 5 Press to select MOVIE PLAYBACK, then press .

- The movie is played back. When playback ends, the display automatically returns to the beginning of the movie.

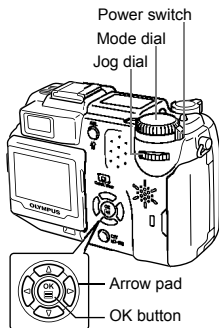



- Press  again after playback ends to display the menu.

PLAYBACK : Plays back the entire movie again.

FRAME BY FRAME :
Plays back the movie manually one frame at a time.





EXIT : Leaves the movie playback mode.

Press   to select from **PLAYBACK**, **FRAME BY FRAME**, or **EXIT**, then press .



2

● When **FRAME BY FRAME** is selected

-  : Displays the first frame of the movie.
-  : Displays the last frame of the movie.
-  : Displays the next frame. The movie can be played continuously by holding the button down.
-  : Displays the previous frame. The movie can be played continuously in reverse by holding the button down.
-  : Displays the **MOVIE PLAYBACK** menu.



TIPS

- Movies can also be played back in the shooting mode using Quick View.  "Quick View" (P.54)



Note

- While the card access lamp blinks, the camera is reading the movie from the card. Reading of movies may take considerable time. Do not open the card cover while the card access lamp is blinking, as this may cause not only the data on the card to be damaged, but may also render the card unusable.



You are recommended to protect important pictures to avoid accidentally erasing them. Protected pictures cannot be erased by the single-frame/all-frame erase function.

Mode dial



1 Set the mode dial to and turn the camera on.

 "Power on/off" (P.31)

- The monitor turns on.

2 Use the arrow pad or jog dial to display the picture you want to protect.

 "Viewing still pictures" (P.53)

3 Press .

- To cancel protection, press  again.

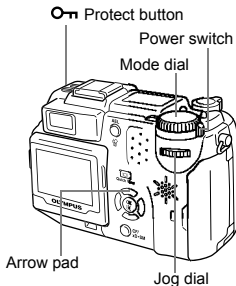

Displayed when a picture is protected.



Note

- Protected pictures cannot be erased by the single-frame/all-frame erase function, but they are all erased by formatting.
- Protection cannot be applied to pictures stored on a card (SmartMedia) with a write-protect seal attached.



Erasing pictures (Single-frame erase)

This function erases only the picture displayed on the monitor. The all-frame erase function can be used to erase all the pictures on the card at once.

 “All-frame erase” (P.163)



Note

- You cannot erase pictures that are protected or stored on a write-protected SmartMedia card. Cancel protection or remove the write-protect seal before erasing such pictures.
- Once erased, pictures cannot be restored. Check each picture before erasing to avoid accidentally erasing pictures you want to keep.  “Protecting pictures” (P.57)
- Pictures protected (read only) by the PC are also erased. To prevent erasure, the pictures have to be protected on the camera.  “Protecting pictures” (P.57)

2

Shooting and playback basics

Mode dial

- 1 Set the mode dial to  and turn the camera on.

 “Power on/off” (P.31)

- The monitor turns on.

- 2 Use the arrow pad or jog dial to display the picture you want to erase.

 “Viewing still pictures” (P.53)

- 3 Press .

- The  ERASE screen is displayed.

- 4 Press   to select YES, then press .

- The picture is erased and the menu is closed.

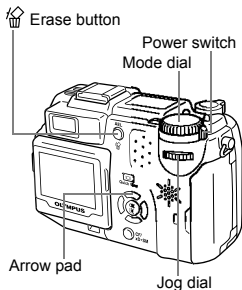

3 Mode dial and direct button functions

Mode dial

The mode dial is used to select a shooting or playback mode. The shooting modes include modes where the optimal settings for the situation are automatically selected, and modes where you can select the settings best suited to the shooting conditions and the effect you wish to achieve.

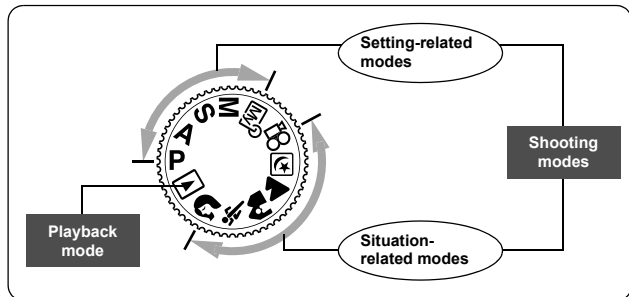

3

Mode dial and direct button functions

Setting-related modes P A S M

P Program shooting

Allows you to take still pictures. The camera sets the aperture and shutter speed. Other functions, such as flash modes and drive modes, can be adjusted manually.

A Aperture priority shooting

Allows you to set the aperture manually. The camera sets the shutter speed automatically. By decreasing the aperture value (F-number), the camera will focus within a smaller range, producing a picture with a blurred background. Increasing the value forces the camera to focus over a wider range in the forward and backward directions, resulting in a picture in which both the subject and the background are in focus.

 "Aperture priority shooting" (P.91)



Aperture (F-number) is decreased.



Aperture (F-number) is increased.

S Shutter priority shooting

3

Mode dial and direct button functions

Allows you to set the shutter speed manually. The camera sets the aperture automatically. Set the shutter speed according to the subject and the type of effect you want.

 "Shutter priority shooting" (P.92)



Setting the shutter speed higher lets you capture fast-moving action without blur. The subject will be clear and sharp, as if it is not moving.



Setting the shutter speed lower blurs a moving subject, giving the impression of movement.

M Manual shooting

Allows you to set the aperture and shutter speed manually. To check the exposure, refer to the exposure differential. This mode gives you more creative control, allowing you to make the settings you need to get the type of picture you want, regardless of optimum exposure.

 "Manual shooting" (P.93)

My Mode

Allows you to save your favorite settings as your own personal mode and use these customized settings when taking pictures. Current settings can also be saved for retrieving by this mode.  “MY MODE SETUP” (P.172)

 “Using My Mode” (P.95)

Situation-related modes

Movie record

Allows you to record movies. The camera sets the aperture and shutter speed automatically. The camera maintains the correct focus and exposure even if the distance between your subject and the camera changes (when the FULLTIME AF is on (factory default setting)).

 “Recording movies” (P.48)

Night Scene shooting

Suitable for shooting pictures in the evening or at night. The camera sets a slower shutter speed than is used in normal shooting. For example, if you take a picture of a street at night in **P** mode, the lack of brightness will result in a dark picture with only dots of light. In the Night Scene shooting mode, the true appearance of the street is captured. The camera automatically selects the optimal settings for this type of shooting condition. Since the shutter speed is slow, make sure you stabilize the camera by using a tripod.

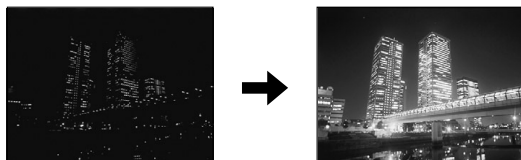

Landscape shooting

Suitable for taking pictures of landscapes and other outdoor scenes. Both the foreground and the background are in focus. Since blues and greens are vividly reproduced in this mode, it is excellent for shooting natural scenery. The camera automatically sets the optimal shooting conditions.

Landscape+Portrait shooting

Suitable for taking pictures of both your subject and the background. The picture is taken with the background as well as the subject in the foreground in focus. You can take pictures of your subject against a beautiful sky or landscape. The camera automatically sets the optimal shooting conditions.

Sports shooting

Suitable for capturing fast-moving action (such as sports) without blur. Even a fast-moving subject will be clear and sharp, as if it is not moving, enabling you to capture facial expressions and detailed activity. The camera automatically sets the optimal shooting conditions.

Portrait shooting

Suitable for taking a portrait-style shot of a person. This mode features an in-focus subject against a blurred background. The camera automatically sets the optimal shooting conditions.

Playback mode



Allows you to play back still pictures and movies. Pictures are edited and print reservation settings are made in this mode.

Use this mode when connecting the camera to a PC.



Note



- The available settings vary depending on the mode.  "List of items by shooting mode" (P.221)



Direct Buttons

This camera is equipped with direct buttons for quick operation and setting of various shooting and playback-related functions. The direct buttons have different functions in the shooting mode and in the playback mode. Holding down one or two direct buttons and turning the jog dial allows you to make settings for each function (such as selecting menu items or changing setting values).

Certain function settings require the direct button to be pressed repeatedly.

Direct buttons and the jog dial

You can change the function settings by turning the jog dial while pressing a direct button such as  or .

This can be achieved smoothly by pressing the direct buttons with the left or right hand while turning the jog dial with the right thumb. The flash intensity control is set by pressing  and  simultaneously while turning the jog dial.

Keep the direct buttons pressed.

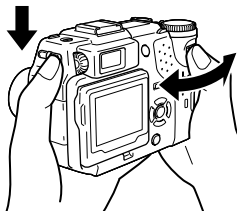

Turn the jog dial.

● Pressing 2 direct buttons simultaneously

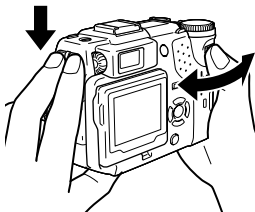

Flow of direct button operations

The procedure for making settings using the direct buttons and jog dial is shown below. As the setting screens are displayed on the monitor when pressing the direct button, settings can be made by following the operation guide displayed at the bottom of the screen.

Ex: Using the flash mode button

1 Turn the jog dial while holding down to select the flash mode.

- The monitor turns on and the setting screen is displayed.
- The setting is made at the moment you release your finger from the direct button, and the monitor turns off.

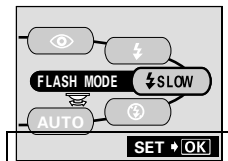
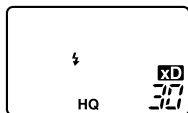

Operation guide:
Displayed when further options are available.

2 Press while holding down to display the menu. Release the direct button after the menu is displayed.

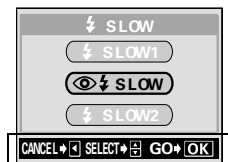

Operation guide:
Possible operations are displayed.

3 Press to select the desired item, then press .

Direct button functions

● Shooting mode

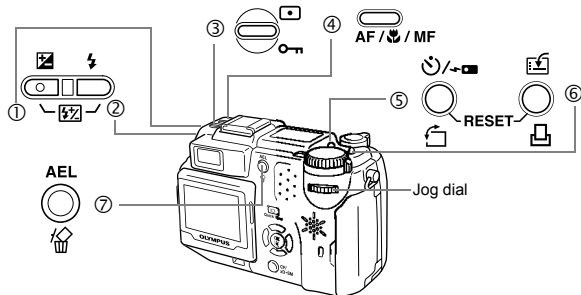

This means to turn the jog dial while holding down the direct button to make function settings.

①  (exposure compensation) button

 P.131

Changes the exposure compensation value.

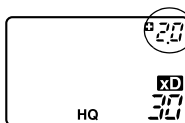

The histogram display can be set.

 P.144

3

Mode dial and direct button functions

② ⚡ (flash mode) button

P.79

Selects a flash mode from auto (no indication), red-eye reduction (👁), fill-in flash (⚡), slow synchronization (⚡ SLOW/👁⚡ SLOW) and flash off (⚡).



Jog dial

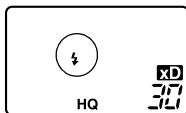

Slow synchronization can be set. P.84

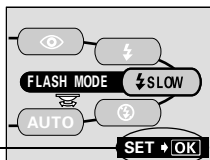

①+②

Press at the same time

⚡ (flash intensity control) button

P.85

Adjusts the amount of light emitted by the flash.



Jog dial

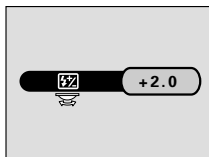
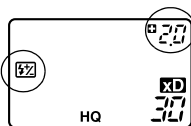

③ 📊 (metering) button

P.102, 103



Selects the metering method from ESP (no indication), spot metering (📊) and multi-metering (MULTI 📊).



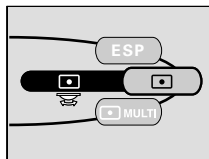
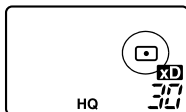

Jog dial



④ **AF /  / MF** (AF/Macro/MF) button  P.100, 107

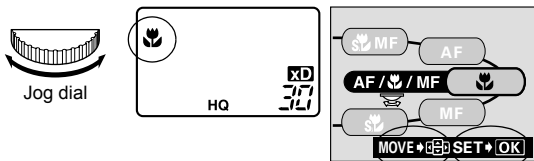

Selects a focus mode from auto-focus (no indication), macro (), manual focus (MF), super macro ( blinks) and super macro MF (MF blinks).



The AF target mark can be moved.  P.98

The AF mode can be set.  P.96

⑤ ** / ** (self-timer/remote control) button  P.109, P.110

Enables the self-timer function () or remote control function ().

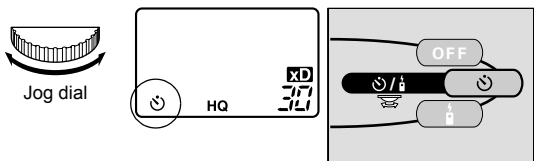
⑥ **** (custom) button  P.166

Activates the function registered on the custom button. See "Custom button" (P.166) for details of how to register a function and use the button.

⑦ **AEL (AE Lock) button**  P.105

Fixes the exposure. The lock function is alternately activated and canceled each time you press the button.

● Playback mode

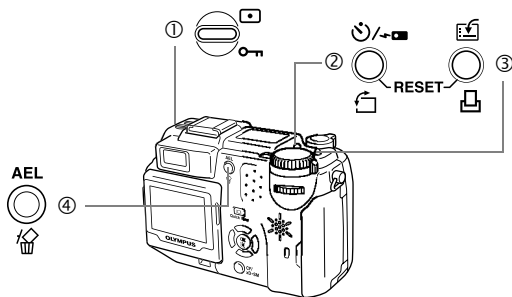

- ①  (protect) button  P.57

Protects important pictures from accidental erasure.

- ②  (rotation) button  P.152



Rotates pictures 90 degrees clockwise or counterclockwise.

- ③  (print) button  P.197

Stores print reservation data on the card.

- ②+③  RESET button  P.193
Press at same time

When pressed simultaneously for at least 3 seconds, resets the camera's internal settings.

- ④  (erase) button  P.58

Erases a selected picture.

4 Using the menus and tabs

About the menus

When you turn on the camera and press , the top menu is displayed on the monitor. The functions of this camera are set from the menu. This chapter explains how the menus work, using the **P** mode screens.

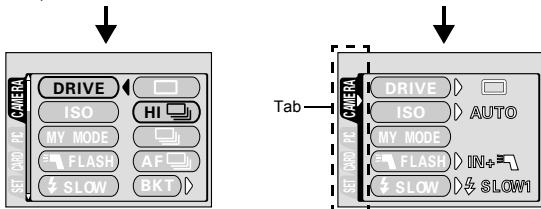
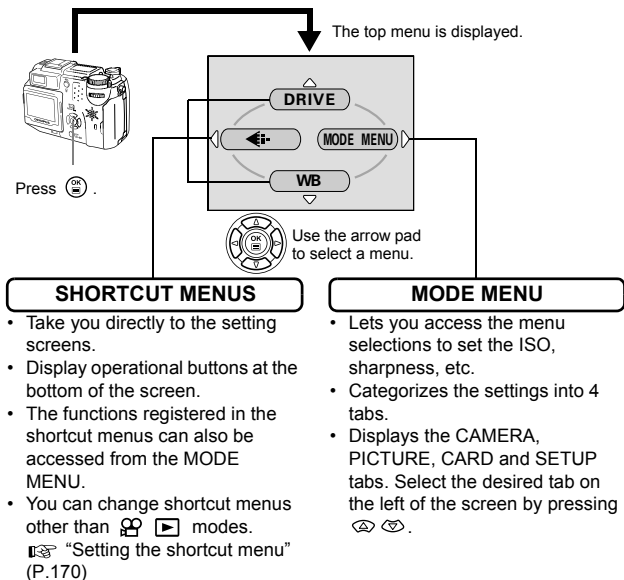

How to use the menus

1 Press to display the top menu. Press .

2 Press to select a tab, then press .

Top menu

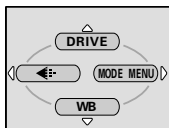

CAMERA tab

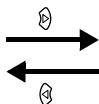
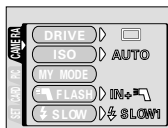

PICTURE tab

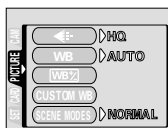

CARD tab

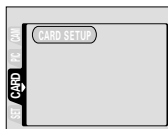

SETUP tab

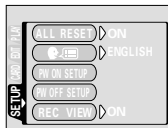

Press to return to the tab selection screen.

4

Using the menus and tabs

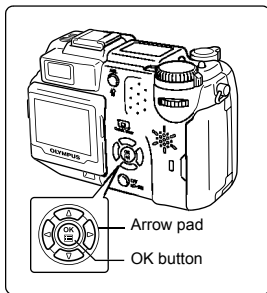

- 3 Press to select an item, then press .

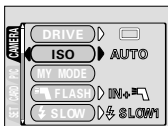
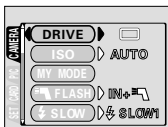

The green frame moves to the selected item.

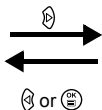

To return to select an item, press or .

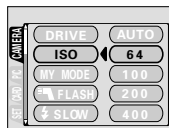
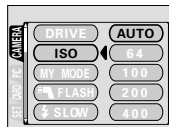

- 4 Press to select a setting. Press to complete setting. Press again to exit the menu and return to shooting status.







Note

- Not all items can be selected depending on the status of the camera and the settings performed.
- Pressing the shutter button with a menu other than the SETUP menu open allows you to take pictures using the settings currently selected.
- If you want to save the settings after the camera is turned off, set ALL RESET to OFF. "All Reset - Saving the camera's settings" (P.164)

Shortcut menus

● Shooting mode

You can change the shortcut menus in the **P A S M**  

    modes to other functions.  “Setting the shortcut menu” (P.170)

You can also access the functions set in the shortcut menus from the MODE MENU.

The shortcut menu set in the default settings are explained below.

P A S M 
     mode
(for still pictures)

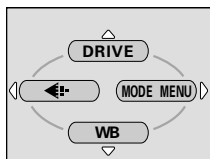





(Factory default setting)

 mode
(for movies)



DRIVE

Selects a shooting mode from  (single-frame shooting), **HI**  (high speed sequential shooting),  (sequential shooting), **AF**  (AF sequential shooting) and BKT (auto bracketing).

P.112

(movies)

Records sound when shooting a movie.

P.124



Sets the image quality and resolution.

Still picture : RAW, TIFF, SHQ, HQ, SQ1, SQ2

Movie : HQ, SQ

P.125

WB

Sets the appropriate white balance according to the light source.

P.133

● Playback mode

Still picture

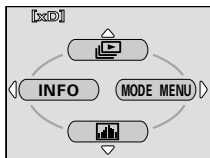

Movie



Runs through all saved pictures one after another.

P.150

MOVIE PLAY

MOVIE PLAYBACK	Plays back movies.	P.55
INDEX	Creates an index picture of a movie in 9 frames.	P.158
EDIT	Edits a movie.	P.160

INFO

Displays all the shooting information on the monitor.

P.177



Displays a histogram showing the luminance distribution of still pictures.

P.144

Mode Menu

The MODE MENU has 4 tabs. Press to select a tab and display the associated menu items.

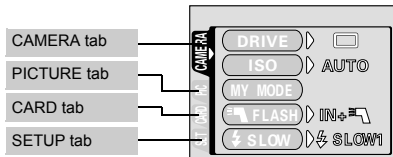

● Shooting mode





4

Using the menus and tabs

CAMERA tab		
DRIVE	Selects a shooting mode from (single-frame shooting), HI (high speed sequential shooting), (sequential shooting), AF (AF sequential shooting) and BKT (auto bracketing).	P.112
ISO	Selects the ISO sensitivity from AUTO, 64, 100, 200 and 400.	P.130
MY MODE	Selects a mode to be activated when taking pictures in mode.	P.95
FLASH	When using an external flash, selects from IN+ , and SLAVE. When "SLAVE" is selected, adjusts the intensity of the main flash.	P.86
SLOW	Selects from SLOW 1 (1st curtain), SLOW (1st curtain with red-eye reduction) and SLOW 2 (2nd curtain) when the flash mode is set to SLOW (slow synchronization).	P.84
NOISE REDUCTION	Reduces the noise that affects pictures during long exposures.	P.142
DIGITAL ZOOM	Extends the maximum optical zoom, making possible up to approx. 10x zoom.	P.51
FULLTIME AF	Keeps the image in focus at all times without having to press the shutter button halfway.	P.97
AF MODE	Selects the auto focus method (iESP or SPOT).	P.96

	Records sound when taking a still picture.	P.122
PANORAMA	Allows panorama pictures to be taken with Olympus CAMEDIA-brand cards.	P.116
2 IN 1	Combines two still pictures taken in succession and stores them as a single picture.	P.119
FUNCTION	Lets you add special effects to pictures (BLACK & WHITE, SEPIA, WHITE BOARD, BLACK BOARD).	P.121
	Displays a histogram showing the luminance distribution of still pictures.	P.144

PICTURE tab





	Sets the image quality and resolution. Still picture : RAW, TIFF, SHQ, HQ, SQ1, SQ2 Movie : HQ, SQ	P.125
WB	Sets the appropriate white balance according to the light source.	P.133
	Lets you make fine changes to the white balance.	P.138
CUSTOM WB	Stores your preferred white balance setting.	P.135
SCENE MODES	Lets you take pictures suited to the situation and the desired effect ().	P.142
SHARPNESS	Adjusts the sharpness of the image.	P.139
CONTRAST	Adjusts the contrast of the image.	P.140
SATURATION	Adjusts the level of color depth without changing the tint.	P.141

CARD tab

CARD SETUP	Formats a card.	P.175
------------	-----------------	-------

SETUP tab

ALL RESET	Selects whether to keep the current camera settings when you turn off the power.	P.164
	Selects a language for on-screen display.	P.34
PW ON SETUP	Sets the picture displayed on the monitor when the power is turned on.	P.186

PW OFF SETUP	Sets the picture displayed on the monitor when the power is turned off.	P.186
REC VIEW	Selects whether to display pictures on the monitor while saving them to a card.	P.181
	Sets the beep sound used for warnings and adjusts the volume.	P.182
BEEP	Sets the beep sound used for button operations and adjusts the volume.	P.183
SHUTTER SOUND	Sets the sound made when the shutter button is pressed and adjusts the volume.	P.184
MY MODE SETUP	Customizes settings which are activated in the  mode.	P.172
FILE NAME	Changes how file names are assigned.	P.189
PIXEL MAPPING	Checks the CCD and image processing functions for errors.	P.190
	Adjusts the brightness of the monitor.	P.180
	Sets the date and time.	P.36
m/ft	Sets the measurement unit (m/ft) used during manual focus.	P.191
VIDEO OUT	Selects NTSC or PAL according to your TV's video signal type. TV video signal types differ depending on the region.	P.192
SHORT CUT	Lets you assign frequently used functions as shortcut menus.	P.169
CUSTOM BUTTON	Lets you assign a frequently used function to the camera's custom button.	P.166
DUAL CONTROL PANEL	Displays the same information on the control panel as on the monitor when the monitor is not in use.	P.178
AF ILLUMINATOR	Turns on the AF illuminator to illuminate a dark subject.	P.99

● Playback mode

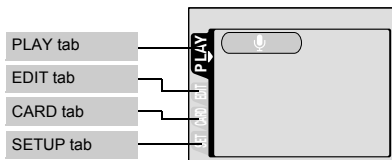





PLAY tab		
	Adds sound to a still picture already taken.	P.153

* The PLAY tab is not displayed during movie playback.

EDIT tab		
RAW DATA EDIT	Sets the image quality, white balance, etc. of pictures taken in RAW data format and saves them as new files.	P.156
	Makes the file size smaller and saves it as a new file.	P.154
	Crops part of a picture and saves it as a new file.	P.155
COPY	Copies pictures to and from cards. Lets you select whether to copy all frames or only a selected frame.	P.162

CARD tab		
CARD SETUP	Formats a card.	P.175
	Erases all image data stored on the card.	P.163

SETUP tab		
ALL RESET	Selects whether to keep the current camera settings when you turn off the power.	P.164
	Selects a language for on-screen display.	P.34

PW ON SETUP	Sets the picture displayed on the monitor when the power is turned on.	P.186
PW OFF SETUP	Sets the picture displayed on the monitor when the power is turned off.	P.186
SCREEN SETUP	Registers a stored picture for use as the picture displayed when the power is turned on or off.	P.187
VOLUME	Adjusts the sound volume during playback. Also adjusts the volume of the sound selected in PW ON SETUP and PW OFF SETUP.	P.185
	Sets the beep sound used for warnings and adjusts the volume.	P.182
BEEP	Sets the beep sound used for button operations and adjusts the volume.	P.183
	Adjusts the brightness of the monitor.	P.180
	Sets the date and time.	P.36
VIDEO OUT	Selects NTSC or PAL according to your TV's video signal type. TV video signal types differ depending on the region.	P.192
	Selects the number of frames in the index display.	P.149

5 Flash

Flash shooting



Select the flash mode best suited to the light conditions and the effect you want to achieve. You can also adjust the amount of light emitted using the flash intensity control.

Mode dial

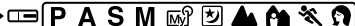

1 Set the flash mode by turning the jog dial while holding down .

- The flash mode changes as follows and the selected mode is displayed on the control panel (if all modes are available):

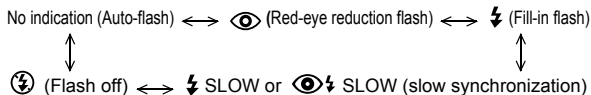
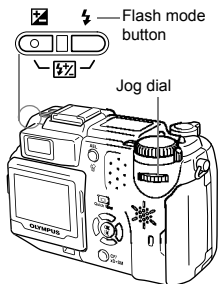
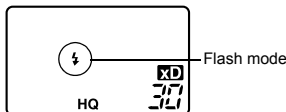

2 Press the shutter button halfway.

- When the flash is ready to fire, the orange lamp lights steady.

3 Press the shutter button fully.

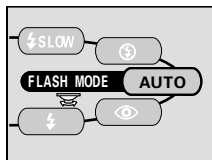

Flash working range

W (max.): Approx. 0.8 m to 5.6 m (2.6 ft. to 18 ft.)

T (max.): Approx. 0.2 m to 3.8 m (0.7 ft. to 12 ft.)

**TIPS**

The orange lamp or the ⚡ (flash standby) indication blinks.

→ The flash is charging. Wait until the orange lamp goes off.

Camera movement warning (Auto-flash, red-eye reduction, fill-in flash)

→ When the orange lamp or ⚡ (camera movement warning) lights, the shutter speed locks at its current level. This helps prevent camera shake problems (shutter speeds that are too slow can cause blur). However, if the zoom magnification is increased, the camera will increase the locked shutter speed accordingly.





Zoom position	Shutter speed
W (max.)	1/30 sec.
T (max.)	1/100 sec.



Note

• AUTO, , , and  SLOW are not available in **S M** mode.

• The flash does not fire in the following situations:

When shooting a bright subject (AUTO, ) in the movie record mode, during sequential shooting (**HI** , , **AF** , BKT), during super-macro shooting, when FUNCTION is set to WHITE BOARD/BLACK BOARD, during Panorama shooting.

- The flash may not give you the optimum result in macro mode, especially with wide-angle shooting. Check the resulting picture on the monitor.
- If a conversion lens is attached to the camera, do not use the flash.

● **Auto-flash (No indication)**

The flash fires automatically in low light or backlight conditions. To shoot a subject with backlight, position the AF target mark over the subject.

● **Red-eye reduction flash (👁)**

The light from the flash may make the subject's eyes appear red in the picture. The red-eye reduction flash mode significantly reduces this phenomenon by emitting pre-flashes before firing the regular flash. This helps accustom the subject's eyes to the bright light and minimizes the red-eye phenomenon.

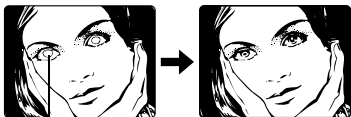

The subject's eyes appear red.



Note

- After the pre-flashes, it takes about 1 second before the shutter is released. Hold the camera firmly to avoid camera movement.
- Effectiveness may be limited if the subject is not looking directly at the pre-flashes, or if the shooting range is too far. Individual physical characteristics may also limit effectiveness.

● **Fill-in flash (⚡)**

The flash fires regardless of the available light. This mode is useful for eliminating shadows on the subject's face (such as shadows from tree leaves), in a backlight situation, or for correcting the color shift produced by artificial lighting (especially fluorescent light).



Note

- The fill-in flash may not have the desired effect under excessively bright light.

● Flash off (🚫)

The flash does not fire even in low light conditions. Use this mode in situations where flash photography is not desired or is prohibited, such as in an art museum. You can also use this mode when you want to shoot a natural-looking twilight or night scene.



Note

- Since a slow shutter speed is automatically selected in low light situations when in the flash off mode, the use of a tripod is recommended to prevent your pictures from being blurred by camera movement.

● Slow synchronization ⚡ SLOW 1 ⚡ SLOW 2 🗨️ ⚡ SLOW

The slow synchronization flash is designed for slow shutter speeds. Normally, when shooting with a flash, shutter speeds cannot go below a certain level to prevent camera movement. But when shooting a night scene background, fast shutter speeds can make the background too dark. Slow synchronization flash allows both a slow shutter speed for the background and a flash for the subject. Since the shutter speed is slow, make sure you stabilize the camera by using a tripod. Otherwise, camera movement may cause the picture to be blurred.

5

Flash



1st curtain (front curtain) ⚡ SLOW 1

Usually, regardless of the shutter speed, the flash fires right after the shutter fully opens. This is called 1st curtain. Unless you change it, this is how the flash always fires.

2nd curtain (rear curtain) ⚡ SLOW 2

In contrast to 1st curtain, 2nd curtain fires the flash just before the shutter closes. Changing the flash timing can create interesting effects in your picture, such as expressing the movement of a car by showing the tail-lights streaming backwards. The slower the shutter speed, the better the effects turn out.

The slowest possible shutter speed depends on the shooting mode:

M mode : 16 sec.

P/A/S mode : 1 sec.

When the shutter speed is set to 4 sec.

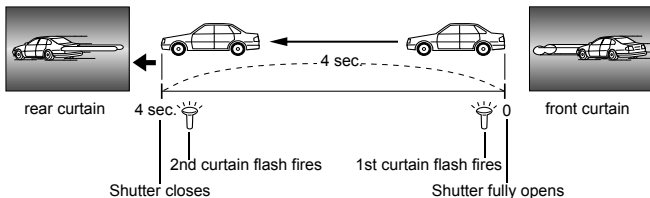

1st curtain with red-eye reduction 👁⚡ SLOW

This mode is for when you want to use slow synchronization, yet also reduce the red-eye phenomenon. For instance, when shooting a person against a brightly lit night background. A normal flash might make the person's eyes red, but 1st curtain with red-eye reduction lets you capture the background correctly and reduce the red-eye phenomenon at the same time. 2nd curtain with red-eye reduction is not available.

Mode dial

P A S M

- 1 Turn the jog dial while holding down and select SLOW.

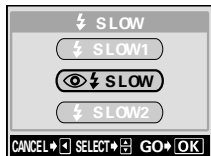
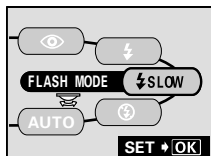
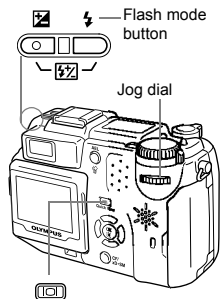

Slow synchronization menu

5

Flash

- 2 While holding down , press .
 - After the slow synchronization menu is displayed, release .
- 3 Press to select SLOW1, SLOW, or SLOW2, then press .



TIPS

Slow synchronization can also be set from the MODE MENU.

→ In the top menu, select MODE MENU → CAMERA → SLOW → SLOW1, SLOW or SLOW2, then press .

“How to use the menus” (P.70)

Flash intensity control



You can adjust the amount of light emitted by the flash.
In some situations, you may get better results by adjusting the light emission. Examples include small subjects, distant backgrounds, or situations when increased contrast is desired. You can adjust the brightness in the range of ± 2.0 in $1/3$ EV steps.

Mode dial



- 1 Adjust the brightness by turning the jog dial while holding down and at the same time.

- The exposure value is displayed on the control panel while the flash intensity control function is set.

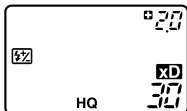

Turning to the left decreases light emission in steps of $1/3$ EV.



Turning to the right increases light emission in steps of $1/3$ EV.

(EV : Exposure Value)

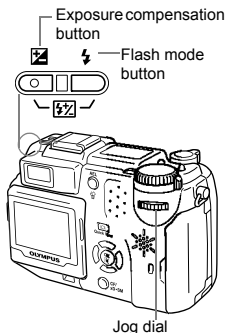

5

Flash



Note

- The flash adjustment effect may not be sufficient if the shutter speed is too fast.

External flash (optional)

Using the FL-40 external flash

Various types of flash shooting are possible with the FL-40 external flash, which can be used either by itself or together with the main flash. If the FL-40 is used, flash mode and exposure compensation will be detected automatically by the camera, allowing the main flash and external flash to function together.

Using the two flashes together allows for more sophisticated lighting, such as catch lighting.

The FL-40 can be mounted on the camera by attaching it to the hot shoe on the top of the camera, or by using the exclusive FL-BK01 flash bracket (optional) and FL-CB02 bracket cable (optional).

Mode dial



- 1 Slide the shoe cover off in the direction of the arrow and attach the external flash.

- For instructions on how to attach the flash, refer to the manual for the FL-40 external flash.
- Keep the shoe cover in a safe place to prevent it getting lost, and replace it on the camera when you have finished using the external flash.



5

Flash

2 In the top menu, select **MODE MENU** → **CAMERA** → **FLASH**.

☞ “How to use the menus” (P.70)

To use the external flash only

→ Select **FLASH**, then press **OK**. To exit the menu, press **OK** again.

To use the external flash together with the main flash

→ Select **IN+ FLASH**, then press **OK**. To exit the menu, press **OK** again.

3 Turn on the external flash.

- The mode for the external flash is TTL-AUTO.
- When the shutter button is pressed halfway, the external flash begins communicating with the camera and automatically switches to TTL-AUTO. During communication, the camera's monitor is turned on and TTL-AUTO is displayed.

4 Select the flash mode by turning the jog dial while holding down **FLASH**.

☞ “Flash shooting” (P.79)

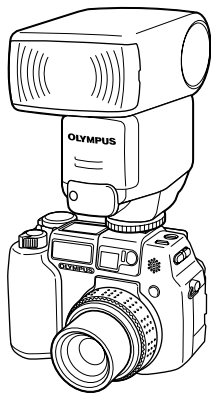

Note

- If close-up pictures are overexposed, try using the main flash by itself.
- When the main flash and the FL-40 are used together, the main flash is used as the compensating light source. This means that if the amount of light from the FL-40 is insufficient (beyond its working range), the resulting pictures may be underexposed.

Using commercially available external flashes

Provided that the flash can be connected to the hot shoe, a commercially available external flash may be used. (Unlike the FL-40, the amount of light emitted cannot be adjusted on commercially available external flashes.) For details on compatible commercially available external flashes, refer to the next page.

Mode dial



1 Attach the external flash to the hot shoe and connect it to the camera.

- For instructions on how to attach the flash, refer to the manual for the external flash.

2 Select **M** mode. Adjust the shutter speed and aperture.

"Manual shooting" (P.93)

- Remember that a slow shutter speed can produce blurred images. For the best results, we recommend that you set the shutter speed from 1/200 to 1/300 seconds.

3 Turn on the external flash.

4 Set the mode that automatically controls the amount of light emitted by the external flash. Also set the ISO sensitivity and aperture on the external flash to match the camera's settings.

- Refer to the user's manual for the external flash to select its mode.

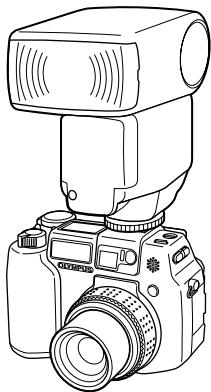

Note

- The camera's flash mode will have no effect on the external flash. The external flash will fire even when the camera's flash mode is set to (off).
- Confirm in advance that the external flash you are using is synchronized with the camera.

Compatible commercially available external flashes



When selecting an external flash, use products which meet the following basic conditions.

- (1) Some flashes available on the market operate with a high voltage synchro terminal. If one of these is used, it may damage the camera, and/or the camera may not function normally. Contact the manufacturer of the flash you are using concerning the specifications of the flash's synchro terminal.
- (2) Some flashes available on the market have the polarity of the synchro terminal reversed. In this case, even if the flash is connected, it will not fire. Contact the manufacturer of the flash for more information.
- (3) Exposures when using an external flash require that adjustments be made on the external flash unit. If an external flash is used in the auto mode, match it with the F value and ISO sensitivity settings on the camera.
- (4) Even if the auto F value and ISO sensitivity of the external flash are set to the same conditions as those on the camera, depending on the photographic conditions, it is possible that the correct exposure may not be obtained anyway. In such a case, adjust the auto F value or ISO value on the external flash unit or calculate the distance in the manual mode and use it that way. Generally, however, the auto F value and ISO value can only be adjusted 1 step and beyond that, exposure compensation cannot be made. (Exposure compensation in the camera is made invalid in external flash photography.)
- (5) Use a flash which is capable of covering an illumination angle for a 35 mm or larger lens when calculated for 35 mm film. However, in close-up photography with the lens on the wide setting, the bottom of the image may not expose correctly. The ideal is to have a wide angle adapter to fit on the flash and spread the illumination angle so it is wider.
- (6) Use a flash unit with a flash time of 1/200 sec. or less when using the flash at full strength. For devices with a long flash time, such as a ring flash, a portion of the light emitted will not contribute to the exposure.
- (7) **If a flash unit or other accessory TTL flash that has additional communications functions other than the FL-40 is used, it may not only fail to function normally, but may also cause damage to the camera's circuitry. Do not use such a device.**

Using a slave flash mode



This setting is for using a commercially available slave flash.

This lets you adjust and fix the amount of light emitted by the commercially available slave flash. If you set a low amount, the flash will fire during sequential shooting. The following restrictions apply to the slave flash mode depending on the selected flash mode.

-  : The setting is changed to AUTO.
-  SLOW : The setting is changed to  SLOW 1.



Mode dial

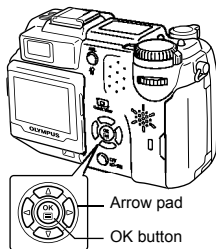

- 1 In the top menu, select MODE MENU → CAMERA →  FLASH → SLAVE, and press .**

 "How to use the menu" (P.70)



- 2 Press   to select the amount of light from 1 to 10, then press .**

6 Advanced shooting

Aperture priority shooting

A

Mode dial



1 Turn the jog dial to set the aperture value.

Turn to the left to decrease the aperture value (F number).



Turn to the right to increase the aperture value (F number).

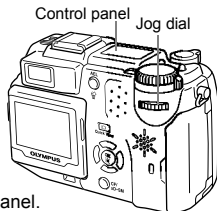

- Pressing the shutter button halfway displays the shutter speed on the control panel.
- If the image is underexposed or overexposed when the shutter button is halfway pressed, the shutter speed indication blinks.

Control panel	Aperture value indication on the monitor	Meaning
	Lights	Displayed in green The aperture setting is suitable for the conditions.
	Blinks	Displayed in red The aperture setting is unsuitable for the conditions. Take the following steps when the monitor is turned on.

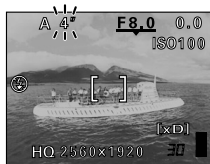
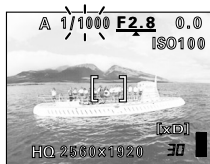

- ▲ appears : The image is overexposed.
Turn the jog dial to the right to increase the aperture value.
 - ▼ appears : The image is underexposed.
Turn the jog dial to the left to reduce the aperture value.
- Aperture range : Toward W : F1.8 to F8.0
Toward T : F2.6 to F8.0

**Note**

- When the flash is set to the auto-flash mode, the shutter speed is fixed at 1/30 sec. in the maximum wide angle, or 1/100 sec. in the maximum telephoto, and will not go slower.

Shutter priority shooting



Mode dial



1 Turn the jog dial to set the shutter speed.

Turn to the left to set a slower shutter speed.



Turn to the right to set a faster shutter speed.

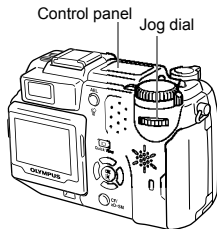

- Pressing the shutter button halfway displays the aperture value on the control panel.
- If the image is underexposed or overexposed when the shutter button is halfway pressed, the aperture value indication blinks.

Control panel	Shutter speed indication on the monitor	Meaning
	Lights	Displayed in green
	Blinks	Displayed in red
		The shutter speed setting is suitable for the conditions.
		The shutter speed setting is unsuitable for the conditions. Take the following steps when the monitor is turned on.



- ▲ appears : The image is overexposed.
Turn the jog dial to the right to set the shutter speed faster.
 - ▼ appears : The image is underexposed.
Turn the jog dial to the left to set the shutter speed slower.
- Shutter speed range : 4 to 1/1000 sec.



Note

- Shutter speeds that can be set differ according to the flash setting.

Mode dial



- 1 Set the aperture by turning the jog dial while holding down .

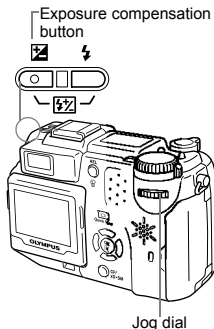
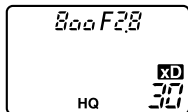

Turn to the left to decrease the aperture value (F number).



+



Turn to the right to increase the aperture value (F number).

Turn the jog dial to set the shutter speed.

Turn to the left to set a slower shutter speed.



Turn to the right to set a faster shutter speed.

- When the shutter button is halfway pressed, the difference (ranging from -3.0 to +3.0 EV) between the exposure determined by the currently selected aperture and shutter speed compared to the exposure level considered optimal by the camera is displayed.
- If the exposure differential appears in red on the monitor, it indicates that the exposure differential is less than -3.0 EV or more than +3.0 EV.

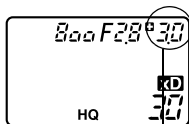

Exposure differential



- When you press the AEL (AE Lock) button, the screen on the right appears with the bar indicating current exposure settings. Pressing the shutter button halfway shows how much the current exposure differs from the correct exposure.

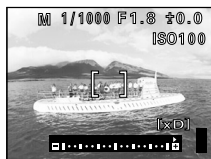

Aperture value : F1.8 to F8.0

Shutter speed : 16 to 1/1000 sec.

(At F8.0, up to 1/2000 sec.)



Note

- To avoid camera movement, you are recommended to use a tripod when taking pictures requiring a slow shutter speed.

When you use My Mode, the settings you selected with the menus in My Mode are activated. Saving the shooting mode or function settings you want to use in advance lets you shoot with your favorite settings straightaway. You can also save the settings you are currently using. You can create and save up to 8 different My Mode settings. “MY MODE SETUP” (P.172)

Mode dial



- 1 In the top menu, select MODE MENU → CAMERA → MY MODE → MY MODE 1 to MY MODE 8, and press .**

“How to use the menus” (P.70)

- Press again to exit the menu.
- Only the settings in MY MODE 1 have already been saved. You cannot select MY MODE 2 to MY MODE 8 if no settings have been saved in them.

“MY MODE SETUP” (P.172)

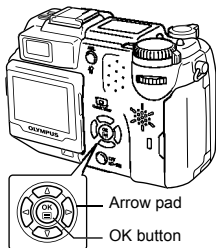

Note

- When you save the settings you are currently using in My Mode and then activate those settings for taking pictures, the zoom position may not be the same as the position that was saved.

Focusing applications

AF MODE - Changing the focus range

This function allows you to select the focus range of your subject.

iESP : Focus selection is based on the entire picture on the screen. Even when the subject is not in the center of the screen, focusing is possible.

SPOT : Focus selection is based on the subject within the AF target mark.



- 1 Turn the jog dial while holding down AF / / MF and select AF, or .

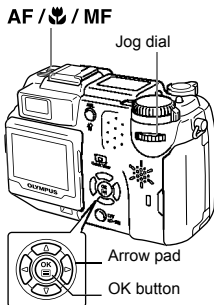

- 2 While holding down AF / / MF , press .
 - The AF MODE menu is displayed.

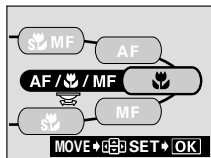

- 3 Press or to select iESP or SPOT, then press .

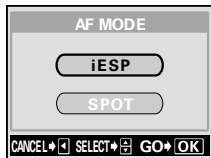

**TIPS****AF MODE can also be set from the MODE MENU.**

→ In the top menu, select MODE MENU → CAMERA → AF MODE → iESP or SPOT, and press .

“How to use the menus” (P.70)



Note

- In mode, the AF MODE is fixed to iESP. The setting cannot be changed.

FULLTIME AF - A reliable time-saving way to focus

FULLTIME AF keeps the subject in front of the lens in focus at all times, without having to press the shutter button halfway. When ON is selected, the focusing time is reduced, letting you take successive snapshots.

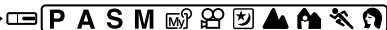
Mode dial

- In the top menu, select MODE MENU → CAMERA → FULLTIME AF → ON, and press .**

“How to use the menus” (P.70)

- The subject is displayed on the monitor.
- If the monitor is turned off, FULLTIME AF does not function.
- Press again to exit the menu.

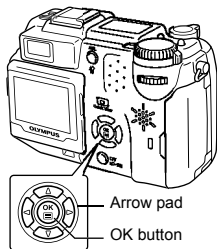





Note

- In mode, FULLTIME AF is set to ON in factory default setting.
- Battery life is reduced when FULLTIME AF is used.

Changing the position of the AF target mark

This function lets you select the area you want to focus on by changing the position of the AF target mark.

Mode dial

P A S M      

1 Set the AF mode to SPOT.

 "AF MODE - Changing the focus range"
(P.96)

AF /  / MF

Jog dial

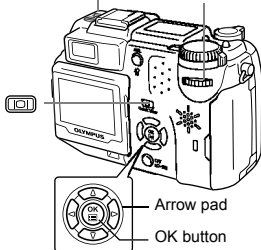

Arrow pad

OK button

6

Advanced shooting

2 Turn the jog dial while holding down AF / / MF, or .

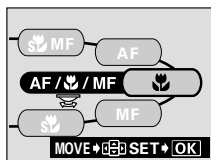

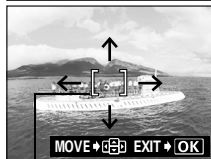

3 While holding down AF / / MF, use the arrow pad and move the AF target mark to the area you want to focus on.

- The AF target mark at the center of the screen can be moved vertically or horizontally.



AF target mark

4 Take the picture.

- To restore the AF target mark to its original position (in the center), press  while holding down **AF** /  / **MF** .
- Press  again to exit AF target mark selection mode.



Note

- The location of the AF target mark cannot be saved.

AF illuminator

The AF illuminator allows the auto focus to focus on dark subjects. When the shutter button is pressed halfway, the AF illuminator fires automatically, lighting up the subject. Factory default setting is ON. To turn the AF illuminator off, follow the procedure below.

Mode dial



- In the top menu, select **MODE MENU** → **SETUP** → **AF ILLUMINATOR** → **OFF**, and press



 "How to use the menus" (P.70)

- Press  again to exit the menu.

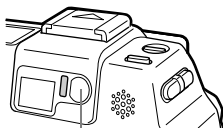

AF illuminator

6

Advanced shooting



Note

- Even when the AF illuminator is lit, the auto focus may still not be able to focus properly on subject within 80 cm (2.6 ft.) of the camera.

Manual focus

If auto focus is unable to focus on a subject, use manual focus.



- Turn the jog dial while holding down AF / / MF and select MF.

- MF is displayed on the control panel.

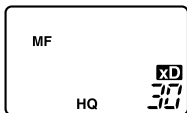

AF / / MF

Jog dial



Arrow pad

OK button

- The monitor turns on when you release AF / / MF.

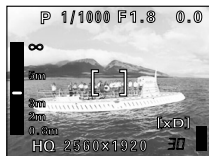

- Press to set the focus distance.

- During operation, the area you are focusing on is enlarged. This lets you check whether the focus is in the right position.
- The distance indicator on the left of the monitor is for reference only.
- When the indicator is moved to less than 0.8 m (2.6 ft.), the display automatically switches to the 20 cm (8") to 80 cm (2.6 ft.) display.

- Press to save the setting.

4 Take the picture.

- The focus is locked at the distance you have set.



TIPS

How to shoot while keeping the same focus distance at all times

→ The focus can be fixed at the same distance as when you perform focus lock.

- Position the AF target mark on an subject at the desired distance and press the shutter button halfway.
- Keeping the shutter button half-pressed, press **AF** / / **MF** .
 - The monitor turns on and displays the distance.
 - MF is selected and the focus is locked at the same distance as when you performed focus lock.
 - Set to AF to return to auto focus.

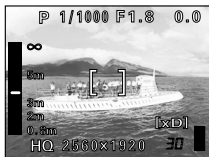

Even if you move the cursor to the top of the distance indicator, focusing is not possible at ∞ .

→ Adjust the cursor position by pressing while watching the monitor.

How to take pictures very close to the subject

→ In super macro MF mode, picture as close as 3 cm from the subject can be taken with manual focus. Turn the jog dial while holding down **AF** / / **MF** and select **MF**. "Super macro mode shooting" (P.108)



Note

- When the digital zoom is set to x2.5 or more, the area you are focusing on is not enlarged.
- If the zoom lever is pressed after performing manual focus, the saved focus distance may be changed. Perform setting again.



There are three ways of measuring the brightness of a subject.

Digital ESP metering : Meters the center of the subject and the surrounding area separately.

Spot metering : Exposure is determined by metering within the AF target area. In this mode, a subject can be shot with optimal exposure regardless of the background light. P.102

Multi-metering : Meters the brightness of the subject at up to 8 different points to set the optimal exposure based on the average brightness. This method is useful with a high contrast subject. P.103

Spot metering

Mode dial

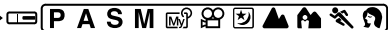

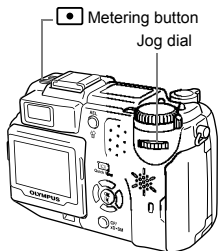
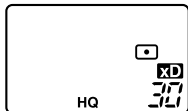

- 1 Turn the jog dial while holding down and select .

• is displayed on the control panel.



Multi-metering



- Turn the jog dial while holding down  and select .
 -  is displayed on the control panel.

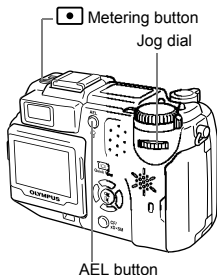

- Position the AF target mark on the area you want to meter and press the AEL (AE Lock) button. The brightness is metered at up to 8 different points.
 - The monitor turns on and the multi-metering bar appears.
 - Brightness meter readings are ignored after the 9th reading.
 - To perform metering again, press the AEL button for more than 1 second to display . Press the AEL button again to cancel the metering values.



Ex: When metering 2 points (pressing the AEL button twice)

The aperture and shutter speed as calculated from the average values obtained by metering at 2 points. These values are recalculated every time another metering point is added.

The average for the 2 metering points. The average is always shown at the center of the bar.

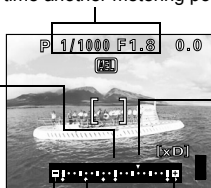

Indicates how much the present exposure you are metering differs from the average exposure value. The present exposure can be fixed by pressing the shutter button halfway. (The present exposure is not added to the average value unless you press the AEL button.)

The reading when the AEL button was pressed. ◇ indicates the number of times you have pressed the button. ◇ indicates the difference between the metered and average readings.

When ◇ moves more than ± 3 from the center of the bar (the average reading), red ◀ ▶ appear.

6

Advanced shooting



TIPS

To save the locked multi-metering exposure after shooting (AE memory)

→ After metering in step 2, hold down the AEL button for more than 1 second. [MEMO] appears. While [MEMO] is displayed, the exposure is saved. Press the AEL button again to cancel the AE memory.

The multi-metering exposure is canceled.

→ If you operate any of the buttons or the mode dial after metering in step 2, the multi-metering exposure is canceled.

This function is suitable for situations when optimal exposure is difficult to achieve, such as when there is excessive contrast between the subject and the surroundings.

For example, if the sun is in the frame and shooting with automatic exposure results in a dark subject, recompose your shot so that the sun is not in the frame. Then press the AEL (AE lock) button to lock the metered value (exposure) temporarily. Next, compose your shot again with the sun in the frame and take the picture.



1 Compose the picture where you want to lock the metered value (exposure), then press the AEL button.

- The monitor turns on and the metered value is saved.
- If you want to lock a different exposure, press the AEL button again to cancel AE lock. Each time you press the AEL button, AE lock is engaged and canceled repeatedly.



2 Position the AF target mark on the subject you want to focus on and press the shutter button halfway.

- The green lamp lights.
- AE lock cannot be canceled after the shutter button is pressed halfway.



3 Press the shutter button fully.

- AE lock is automatically canceled after one shot.

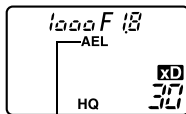

During AE lock, AEL is displayed.

**TIPS****To save the locked multi-metering exposure after shooting (AE memory)**



- After setting AE lock in step 1, or after pressing the shutter button halfway in step 2, hold down the AEL button for more than 1 second. **MEMO** appears. While **MEMO** is displayed, the exposure is saved. Press the AEL button again to cancel the AE memory.

AE lock was canceled.

- Do not operate any of the buttons or the mode dial after performing AE lock. Doing so will cancel AE lock.
- The camera had emerged from sleep mode or the power was turned off.



Note

- AE lock is not available when multi-metering is enabled. Set the metering method to ESP or .  "Spot metering" (P.102)
- AE lock is not available when a menu is displayed on the screen. Exit the menu.  "How to use the menus" (P.70)

Macro mode shooting



The macro mode allows you to shoot at a distance of 20 cm to 80 cm (0.7 ft. to 2.6 ft.) from your subject.

Focusing is usually slow when you get close to a subject. However, in the  mode focusing is performed quickly. When the optical zoom lever is at the maximum wide position and you are as close as 20 cm (0.7 ft.) to your subject, you can fill the entire frame with your subject.



Normal shooting



With the macro mode



- 1 Turn the jog dial while holding down **AF /  / MF** and select .

-  is displayed on the control panel.

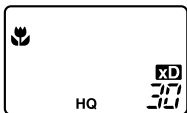

AF /  / MF

Jog dial

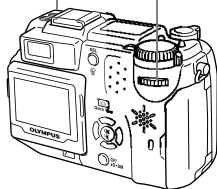

- The subject is displayed on the monitor when you release your finger from the **AF /  / MF** button.



Note

- If you are close to a subject, the picture in the viewfinder is different from the area that the camera actually records. For macro mode shooting, we recommend using the monitor.
- If you use the flash in macro shooting, shadows may be conspicuous and the correct exposure may not be achieved.

6

Advanced shooting

This mode lets you shoot from as close as 3 cm (1.2") to your subject. Subjects measuring up to approximately 2.7 cm × 3.7 cm (1.1" × 1.5") can be captured on the monitor.

In the mode, normal shooting is also possible, but the position of the zoom is fixed automatically and cannot be changed.

Mode dial

P A S M

- 1 Turn the jog dial while holding down AF / / MF and select .

- on the control panel blinks.

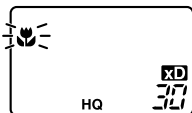

- The subject is displayed on the monitor when you release your finger from the AF / / MF button.

AF / / MF

Jog dial



6

● Super macro MF

When taking pictures close to the subject, shadows may become conspicuous, and the auto focus may not be able to maintain correct focus. Set the camera to super macro MF and use manual focus.

- 1 Turn the jog dial while holding down AF / / MF and select MF (super macro MF).
 - MF on the control panel blinks.
- 2 When you release your finger from the AF / / MF button, the subject and the distance indicator for manual focus are displayed on the monitor.
- 3 Press to adjust the focus.



Note

- During super macro shooting, zoom is not available.
- During super macro shooting, the main flash is not available. You can use an external flash, but vignetting may occur. Check the recorded image on the monitor.



This function lets you take pictures using the self-timer. Fix the camera securely on a tripod for self-timer shooting. This function is useful for taking pictures where you want to be included in the photograph.

Mode dial

P A S M

- 1 Turn the jog dial while holding down and select .

- is displayed on the control panel.

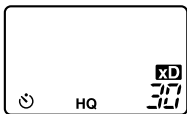

Self-timer/
Remote control button

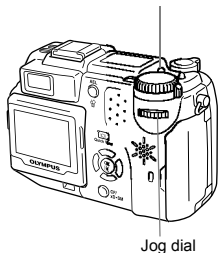

Jog dial

- 2 Press the shutter button fully to start self-timer shooting.

- Pressing the shutter button halfway locks the focus and exposure.
- The self-timer/remote control lamp lights for approximately 10 seconds, then starts blinking. After blinking for approximately 2 seconds, the picture is taken.
- To stop shooting while in mode, press the shutter button fully again.
- To cancel the self-timer, press .
- The self-timer mode is automatically canceled after one shot.

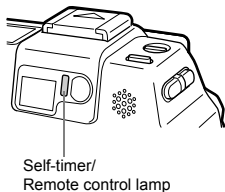

Self-timer/
Remote control lamp



- If sequential shooting is attempted in self-timer mode, the camera shoots max. 5 frames regardless of the setting.



Note



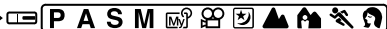

Shooting is possible using the remote control device (sold separately in some regions). This is useful when you want to take a picture with yourself in it, or a night scene, without touching the camera.

Mode dial

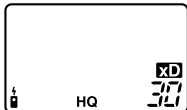

- 1 Mount the camera on a tripod or place it on a stable, flat surface.
- 2 Turn the jog dial while holding down  and select .
 -  is displayed on the control panel.



 Self-timer/
Remote control button

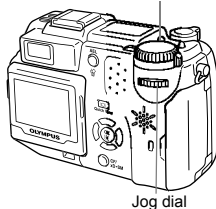

Jog dial

- 3 Point the remote control device at the remote control receiver on the camera. For zooming, press the W or T button on the remote control device.

- You can operate the zoom on the camera. During operation, the self-timer/remote control lamp blinks.

Self-timer/
Remote control lamp

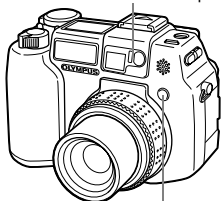

Remote control
receiver

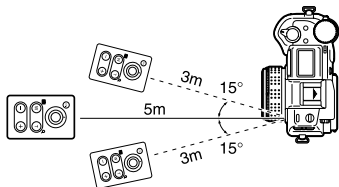

4 Press the shutter button on the remote control device.

- The focus and exposure are locked. The self-timer/remote control lamp blinks for about 2 seconds before taking the picture.



TIPS

The self-timer/remote control lamp does not blink after pressing the shutter button on the remote control device.

- The remote control device may be too far from the camera. Move closer to the camera and press the shutter button on the remote control device again.
- There is signal interference. Change the channel as described in the remote control device's instruction manual.

How to cancel the remote control mode.

- The remote control mode is not canceled automatically after shooting. Perform step 2 on page 110 and set the mode to OFF.







Note

- If the remote control receiver is exposed to strong light, the effective signal distance may be reduced or shooting may not take place.
- To shoot sequential shots using the remote control device, press and hold the shutter button on the remote control device. If the camera does not receive the remote control signal properly, sequential shooting may stop.
- Read the remote control device's instruction manual for information on playback by remote control device.

There are 4 sequential shooting modes: high speed sequential shooting, sequential shooting, AF sequential shooting and auto bracketing. Sequential shooting modes can be selected from the DRIVE mode menu.

Sequential shooting cannot be performed when the record mode is set to TIFF.

Drive mode





-  Shoots 1 frame at a time when the shutter button is pressed. (Normal shooting mode, single-frame shooting)
- HI**  Pictures can be taken at a faster speed than normal sequential shooting. The sequential shooting speed varies depending on the record mode setting.
 - 4 frames at 3.3 frames/sec. (3 frames in SHQ ENLARGE SIZE mode)
 - Approx. 11 frames at 1.7 frames/sec. (in HQ mode)
- AF**  Focus is individually locked for each frame. The AF sequential shooting speed is slower than for normal sequential shooting.
- BKT**  "Auto bracketing" (P.113)

High speed sequential shooting, sequential shooting and AF sequential shooting

6



1 In the top menu, select MODE MENU

- CAMERA → DRIVE → HI ,
-  or AF , and press .
-  "How to use the menus" (P.70)

- Press  again to exit the menu.

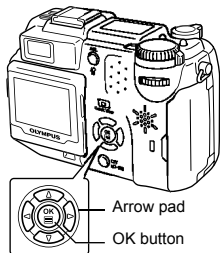

2 Take the picture.

- Press the shutter button fully and keep it pressed. The camera will take pictures in sequence until you release the button.
- You are recommended to use the viewfinder for sequential shooting. During sequential shooting, the subject does not appear on the monitor.

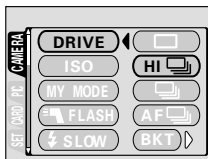

Auto bracketing

Under some conditions, you may obtain better results shooting with exposure compensation than by using the exposure setting considered optimal by the camera.

When auto bracketing is set, the exposure is changed automatically for each frame when you start shooting. The exposure differential and number of frames can be selected in the menus. The focus and white balance are locked at the first frame.

Ex : When BKT is set to ± 1.0 x3

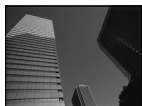

-1.0



± 0



+1.0

Mode dial



P

A

S



- 1 In the top menu, select **MODE MENU** → **CAMERA** → **DRIVE** → **BKT**, and press .

 "How to use the menus" (P.70)

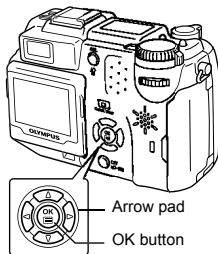

Arrow pad

OK button

6

Advanced shooting

2 Press to select ± 0.3 , ± 0.7 or ± 1.0 , then press .

3 Press to select x3 or x5, then press .

- In some combinations of picture size and record mode, only x3 is available.
- Press repeatedly until menu disappears.

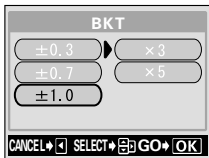

4 Take the picture.

Press the shutter button fully and keep it pressed to shoot the preset number of pictures. You can stop shooting at any time by releasing the shutter button.



Note

- Sequential shooting (**HI** , , **AF** , BKT) is not possible in the following situations:
 - When the record mode is set to TIFF.
 - When NOISE REDUCTION is set to ON.
- and **AF** are not available when the record mode is set to RAW.
- In sequential shooting mode (**HI** , , **AF** , BKT), the main flash does not fire. The external flash does not fire in BKT mode.
- If there is not enough space available on the card for the number of frames you have set during auto bracketing, you cannot continue shooting.
- If self-timer shooting is attempted when the still picture shooting mode is set to sequential shooting, the camera shoots 5 frames automatically.
- If the ISO is set to over 200, noise may appear under some shooting conditions.
- If the battery power is low and the battery check blinks during sequential shooting, shooting stops and the camera starts saving the pictures you have taken. Whether or not all of the shots are saved depends on how much battery power remains.

- Since the shutter speed is set to 1/30 sec. max., exposure is decreased when shooting a dark subject to prevent camera movement.
- To use the external flash during sequential shooting, set the external flash so that it fires for each frame.

Panorama shooting

You can take advantage of panorama shooting with Olympus CAMEDIA-brand cards (xD-Picture Card and SmartMedia Card). Panorama shooting lets you connect pictures with overlapping edges into a single panoramic picture, using the CAMEDIA Master software.

Mode dial



- 1 In the top menu, select **MODE MENU** → **CAMERA** → **PANORAMA** and press

"How to use the menus" (P.70)

- The PANORAMA mode is set. The subject is displayed on the monitor.

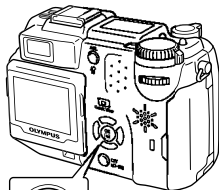

- 2 On the monitor, use the arrow pad to choose the direction you want the pictures connected. Use the arrow pad to choose at which edge you want to connect the pictures.

- : Connects the pictures from left to right.
- : Connects the pictures from right to left.
- : Connects the pictures from bottom to top.
- : Connects the pictures from top to bottom.

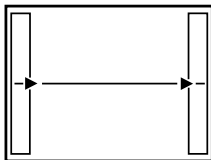

Connects pictures from left to right.

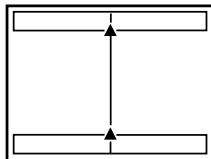

Connects pictures from bottom to top.

3 Make sure that the edges of the pictures overlap, then take pictures.

- Focus, exposure and white balance are set by the first picture. Do not select an extremely bright subject (such as the sun) for the first picture.
- You cannot adjust the zoom after the first picture.
- Panorama shooting is possible for up to 10 pictures.

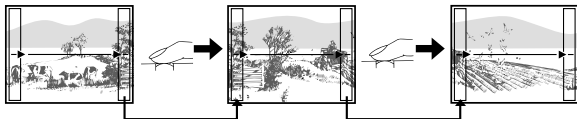

When shooting, make sure that the edges (right/left/top/bottom) of the images overlap, so that you will know which pictures should be connected.

- When you have taken 10 pictures, a warning mark appears.



4 Press to finish panorama shooting.

- The frame on the screen disappears and the camera returns to the normal shooting mode.



Note

- The panorama mode is only available with Olympus CAMEDIA-brand cards.
- Your computer's memory may be insufficient if you take too many panorama pictures in HQ or SHQ mode. You are recommended to use SQ mode for panorama shooting.
- During panorama shooting, the flash and sequential shooting are not available.
- Images are saved in JPEG format when panorama shooting is done in the TIFF mode. The size of the image does not change.

- If the mode dial is operated during panorama shooting, the camera cancels the panorama mode and returns to normal shooting.
- The camera itself cannot connect panorama pictures. The CAMEDIA Master software is necessary to connect the pictures.

Taking two-in-one pictures

2 IN 1

This function allows you to combine two pictures taken in succession and store them as a single picture. You can combine two different subjects in one picture.



Picture when played back

Mode dial

- 1 In the top menu, select MODE MENU → CAMERA → 2 IN 1, and press .**

 "How to use the menus" (P.70)

- The two-in-one picture mode is set. The monitor turns on automatically.

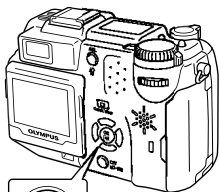

- 2 Take the first shot while observing your subject on the monitor.**

- The subject will be positioned on the left in the combined picture.

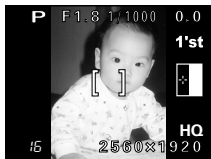

- 3 Take the second shot.**

- The subject will be positioned on the right in the combined picture.

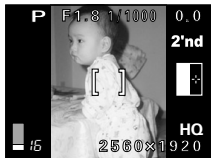



Picture when shooting

6**Advanced shooting**



Note

- During two-in-one picture shooting, the panorama and sequential shooting are not available.
- When the batteries are exhausted ( is displayed), the flash automatically turns off.
- To cancel the two-in-one picture mode after the first shot has been taken, press . The first shot will not be saved.
- Operating the mode dial will exit two-in-one picture mode.

FUNCTION - Adding special effects to pictures

This feature lets you add special effects to your pictures during shooting. 4 effects are available.

BLACK & WHITE : Takes pictures in black and white.

SEPIA : Gives pictures a sepia tone.

WHITE BOARD : Pictures are in black and white, with black letters on a white background emphasized to make them easier to read.

BLACK BOARD : Same as WHITE BOARD, but with white letters on a black background.

Mode dial

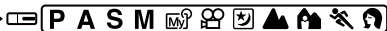

- 1 In the top menu, select **MODE MENU** → **CAMERA** → **FUNCTION**, then select a mode and press .

“How to use the menus” (P.70)

- WHITE BOARD and BLACK BOARD are not available in mode.
- Press again to exit the menu.

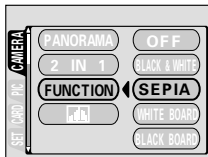
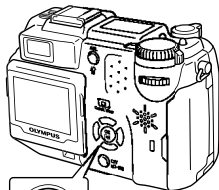

TIPS

Letters do not show clearly with **WHITE BOARD** or **BLACK BOARD**.

→ Use exposure compensation. “Exposure compensation” (P.131)



Note



- When WHITE/BLACK BOARD is selected, the flash is automatically set to off.
- WB, and SATURATION cannot be used in Function shooting.

Recording sound with still pictures



Sound can be recorded when taking still pictures. Recording starts about 0.5 seconds after the shutter is released and lasts about 4 seconds. When this function is enabled, sound is recorded automatically every time you take a picture.

Mode dial



- 1 In the top menu, select **MODE MENU** → **CAMERA** →  → **ON**, and press .

 "How to use the menus" (P.70)

- Press  again to exit the menu.
-  lights on the control panel.

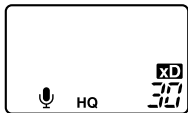
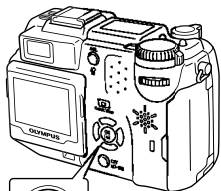

- 2 When recording starts, turn the camera microphone towards the source of the sound you want to record.

- The busy bar is displayed during recording.
- The green lamp blinks during recording and  blinks on the control panel.

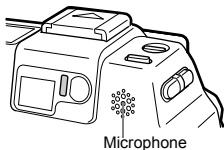

6

Advanced shooting

**TIPS**

- appears on all still pictures and movies that have recorded sound. During playback, sound is output from the speaker. The volume can be adjusted. “Playback volume” (P.185)
- Sound can be added later to still pictures. Recorded sound can also be changed. “Recording sound” (P.153)



Note

- If the camera is more than 1 m (3.3 ft.) away from the source of the sound, sound may not be recorded clearly.
- It is not possible to take another picture during sound recording.
- Sound recording is not possible in the following cases:
the record mode is set to TIFF/the drive mode is set to sequential shooting (**HI** , , **AF**)
- Sound recording may also pick up camera noises, such as button operations, shutter movement, etc.

Recording sound with movies



Sound can be recorded while shooting a movie.

Mode dial



- 1 In the top menu, select → ON, and press .

"How to use the menus" (P.70)

- lights on the control panel.

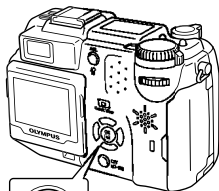

- 2 Recording starts at the same time as shooting.

- During recording, blinks on the control panel.

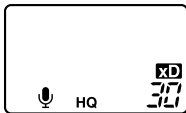

6



Note



- When is set to ON, the optical zoom cannot be used. If is set to OFF, you can use both the optical zoom and digital zoom during movie recording.
- If the camera is more than 1 m (3.3 ft.) away from the source of the sound, sound may not be recorded clearly.

7 Adjusting the image quality and exposure

Record mode



You can select a record mode in which to take pictures or shoot movies. Choose the best record mode for your purpose (printing, editing on a PC, website editing, etc.). For details of the different record modes, resolutions and number of pictures storable on the card, refer to the table on the next page. The numbers in the table are approximate.

Record mode	Description	Quality	File size
RAW	As the name suggests, the data is "raw", not having been subjected to image processing. After taking the pictures, they can be edited using the RAW editing function and can be stored using the record modes below. They can also be edited on a PC using dedicated software.	—	—
TIFF	The highest quality mode. As the images are saved as uncompressed data, this is the best mode for printing or image-processing on a PC. This mode has different resolutions to choose from, depending on your purpose. Selecting 3:2 lets you print the entire image without losing its borders - almost the same image size as that used by photo labs.		
SHQ	A high quality mode using the JPEG format. Because the compression rate is very low, high quality can be maintained. Selecting 3:2 lets you print the entire image without losing its borders - almost the same image size as that used by photo labs. The ENLARGE SIZE function is useful when printing on large-format paper such as A3 (297mm × 420mm/11.7" × 16.5").		
HQ	A high quality mode with medium compression. Because the compression rate is higher than SHQ, file sizes are smaller, so more images can be saved to a card. Like SHQ, resolution can be increased by using 3:2 or the ENLARGE SIZE function.		
SQ1 SQ2	The most compressed modes. For each resolution, you can choose HIGH (to reduce noise) or NORMAL (to save more images). Select the best setting for your purpose (printing, Internet pages, etc.).		
		Clearer	Larger
		Normal	Smaller

Still Picture Record Modes

Record mode	Resolution		Compression	File format	Memory capacity in no. of shots		File size (MB)
					32 MB		
					With sound	Without sound	
RAW	2560 × 1920		Uncompressed	ORF	4	4	7.4
TIFF	2560 × 1920		Uncompressed	TIFF	—	2	14.7
	3:2	2560 × 1696			—	2	13.0
	2288 × 1712				—	2	11.8
	2048 × 1536				—	3	9.4
	1600 × 1200				—	5	5.8
	1280 × 960				—	8	3.7
	1024 × 768				—	13	2.4
SHQ	2560 × 1920		Low compression	JPEG	8	8	3.6
	3:2	2560 × 1696			9	10	3.2
	ENLARGE SIZE 3200 × 2400				6	6	4.7
HQ	2560 × 1920		NORMAL	JPEG	25	26	1.2
	3:2	2560 × 1696			28	29	1.1
	ENLARGE SIZE 3200 × 2400				16	16	1.9
SQ1	2288 × 1712	HIGH	*	JPEG	11	11	2.7
		NORMAL			31	32	1.0
	2048 × 1536	HIGH			14	14	2.2
		NORMAL			39	40	0.8
	1600 × 1200	HIGH			22	22	1.4
		NORMAL			60	64	0.5
SQ2	1280 × 960	HIGH			33	34	0.9
		NORMAL			90	99	0.3
	1024 × 768	HIGH			51	53	0.6
		NORMAL			132	153	0.2
	640 × 480	HIGH			117	132	0.2
		NORMAL			248	331	0.1

*HIGH uses low compression/NORMAL uses standard compression

Movie Record Modes

Record mode	Resolution	32 MB	
		With sound	Without sound
HQ	320 × 240 (15 frames/sec.)	93 sec.	96 sec.
SQ	160 × 120 (15 frames/sec.)	374 sec.	424 sec.





Note

- The card memory capacity listed in the table is approximate.
- The number of remaining pictures may change according to the subject or factors like whether print reservations have been made or not. In certain instances, the number of remaining pictures displayed on the control panel or the monitor does not change even when you take pictures or stored images are erased.
- If movies are shot with VIDEO OUT set to PAL and the AV cable connected, the movie recording time will differ from the time listed in the Movie Record Modes table.



Selecting a record mode

Mode dial



- 1 In the top menu, select **MODE MENU** → **PICTURE** → , and press .

 "How to use the menus" (P.70)

- If  is displayed on the top menu as a shortcut menu, press the arrow pad in the same direction as the arrow shown next to .

 "Setting the shortcut menu" (P.170)





Arrow pad

OK button



Mode dial









- In the top menu, press  to select .

 "How to use the menus" (P.70)





- 2 Press   to select the desired record mode. For still pictures, choose one of the following record modes: RAW, TIFF, SHQ, HQ, SQ1, SQ2. For movies, choose the HQ or SQ record mode.
 Go to Step 4.

- 3 If you have selected TIFF, SHQ, HQ, SQ1 or SQ2 for the still picture record mode, press  to display the screen for selecting the resolution, then choose the resolution by pressing  .

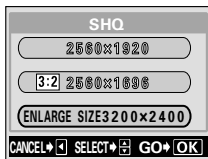
If you have selected SQ1 or SQ2, press  after choosing the resolution, then choose HIGH or NORMAL by pressing  .



- 4 Press .
- Press  again to exit the menu.



TIPS

- **Resolution**

The number of pixels (horizontal × vertical) used when saving an image. If the image will be printed, higher resolutions (larger numbers) are recommended so that the image will be clearer. However, higher resolutions make the file size (amount of data) larger, so the number of pictures that can be saved will be fewer.

- **Resolution and picture size on a computer screen**

When a picture is transferred to a computer, the size of the picture on the computer screen varies depending on the computer's monitor setting. For instance, a picture taken in 1024 × 768 resolution is the same size as the screen if you set the picture to 1x when the monitor setting is 1024 × 768. However, if the monitor setting is over 1024 × 768 (such as 1280 × 1024), the picture only takes up part of the screen.

- **Compression rate**

In record modes other than TIFF, image data are compressed. The higher the compression rate, the less clear the image will be.

- **File format**

This camera saves images in either TIFF or JPEG format. In record modes other than TIFF, images are compressed in the JPEG format. The compression rate also varies in each mode. (Movies are in Motion JPEG format (.mov).)

3:2 Resolution

The image aspect ratio is normally 4:3. If the aspect ratio is changed to 3:2, the image can be printed at a photo lab without losing the image borders. When **3:2** is activated, the resolution is 2560 × 1696 pixels. You can select **3:2** in the TIFF, SHQ or HQ mode. **3:2** is not available in  mode.

The monitor turns on automatically when **3:2** is selected. Check the shooting range on the monitor before taking the picture.



Monitor indications when **3:2** is set

ENLARGE SIZE

When ENLARGE SIZE is selected, the actual 5 million pixels used by this camera can be increased to the equivalent of approx. 8 million pixels (3200 × 2400). This allows you to make quality prints in larger sizes, such as A3 (297 mm × 420 mm/11.7" × 16.5"). However, file sizes also become larger. ENLARGE SIZE can be selected in the SHQ or HQ mode. It is not available in  mode.



Note

- If the SHQ record mode is set to ENLARGE SIZE, the maximum number of pictures in high speed sequential shooting mode is 3.

RAW Data

As its name suggests, RAW data is unprocessed image data in its original state to which white balance, sharpness, contrast, color conversion and other processes have not been applied. CAMEDIA Master software is required to display RAW data as images. Plug-in software for playback by Photoshop can also be used. (Available for download from the Olympus home page.) You cannot display RAW data using ordinary software or make print reservations for them.

Pictures taken with the RAW data format can be edited on this camera.

 "RAW editing" (P.156)

ISO sensitivity

The higher the ISO value, the greater the camera's light sensitivity and the better its ability to shoot in low light conditions. However, higher values also introduce electrical noise into the resulting image, which may give them a grainy appearance.

AUTO : Sensitivity is automatically adjusted according to the light conditions and the subject brightness.

64/100/200/400: With a lower ISO setting, you can shoot clear, sharp images in daylight. With a higher ISO setting, you can use faster shutter speeds with the same amount of light.

Mode dial



- In the top menu, select MODE MENU → CAMERA → ISO, then choose the most suitable ISO sensitivity and press .**

 "How to use the menus" (P.70)

- AUTO is not available in A, S or M mode.
- Press  again to exit the menu.
- When ISO sensitivity is not set to auto, ISO is displayed on the control panel.

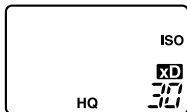
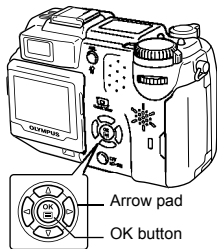

Note

- Higher ISO settings produce more electrical noise.
- ISO is standardized based on the sensitivity of normal camera film. The scale is approximate.
- When ISO is set to AUTO and you are shooting in dark conditions without a flash, the sensitivity automatically increases, otherwise the shutter speed will be reduced, possibly resulting in camera movement and blurred images.
- If the subject is too far away for the flash illumination to reach when ISO is set to AUTO, the sensitivity is automatically increased.
- When using slow synchronization in the P, A or S mode, the slowest available shutter speed varies depending on the ISO setting.

Exposure compensation



This function allows you to make fine changes to the present exposure setting using the  (exposure compensation) button and jog dial. In some situations, you may get better results when the exposure that the camera sets is compensated (adjusted) manually. You can adjust the exposure in the range of ± 2.0 in $1/3$ steps. When the setting is changed, you can check the result on the monitor.

Mode dial



1 Turn the jog dial while holding down .

- Adjust toward + : Turn to the right to adjust up to +2.0 in $1/3$ steps.
- Adjust toward - : Turn to the left to adjust up to -2.0 in $1/3$ steps.
- The exposure compensation value is displayed on the control panel.

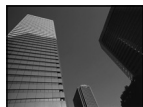
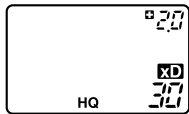
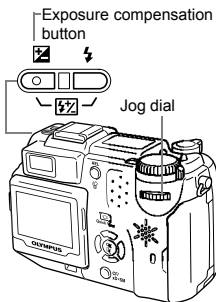

-2.0



±0



+2.0

7

Adjusting the image quality and exposure

**TIPS**

- Often bright subjects (such as snow) will turn out darker than their natural colors. Adjusting toward + makes these subjects closer to their real shades. For the same reason, adjust toward - when shooting dark subjects.
- Pressing when the monitor is turned on and HISTOGRAM is set to ON displays the histogram on the monitor.
- If you press while holding down , the screen for setting the histogram display will appear. You can turn the histogram display on and off from this screen. “Histogram display” (P.144)
- You can change the position of the histogram target mark.
 “Changing the position of the histogram target mark” (P.146)
- The histogram cannot be displayed in **M** mode.

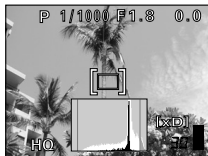
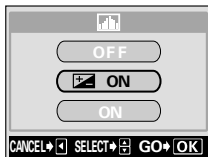

Note

- You can set the aperture by turning the jog dial while holding down in M mode. “Manual shooting” (P.93)
- If the flash is used, the image brightness (exposure) may differ from the intended brightness.
- Exposure compensation cannot correct the image if the surroundings of the subject are extremely bright or dark.

7

Color reproduction differs depending on the light conditions. For instance, when daylight, the setting sun or tungsten lighting are reflected on white paper, the shade of white produced will be slightly different for each. By setting the WB (white balance), you can achieve more natural-looking colors.

Mode dial

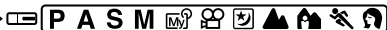

- In the top menu, select **MODE MENU** → **PICTURE** → **WB**, and press .

“How to use the menus” (P.70)

- If WB is displayed on the top menu as a shortcut menu, press the arrow pad in the same direction as the arrow shown next to WB.

“Setting the shortcut menu” (P.170)

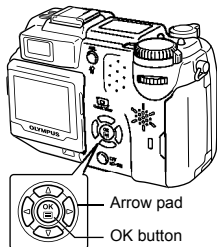

- Press to select the white balance best suited to the shooting conditions. Choose from **AUTO**, **PRESET1**, **PRESET2**, **CUSTOM** and (**one-touch**).

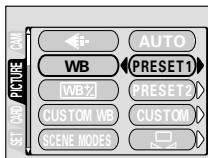

- | | | |
|---------|---|---|
| AUTO | : | Press . Press again to exit the menu. |
| PRESET1 | : | Press to display the next selection screen.
“Preset 1 white balance” |
| PRESET2 | : | Press to display the next selection screen.
“Preset 2 white balance” |
| CUSTOM | : | Press to display the next selection screen.
“Custom white balance” |
| | : | Press to display the next selection screen.
“One-touch white balance” |

Auto white balance

Automatically adjusts the white balance for any light source.

Preset 1 white balance

Select a white balance setting according to the type of light when shooting outdoors. Press to select one of the following settings, then press .

Press again to exit the menu.

- : For shooting in the shade.
- : For shooting on a cloudy day.
- : For shooting on a sunny day.
- : For shooting in evening sunlight.

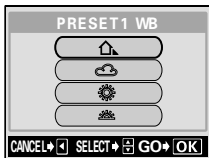

Preset 2 white balance

Select a white balance setting according to the type of light when shooting indoors. Press to select one of the following settings, then press .

Press again to exit the menu.

- : For shooting under a daylight fluorescent lamp (6700K)*. This type of lamp is used mainly in homes.
- : For shooting under a neutral white fluorescent lamp (5000K)*. This type of lamp is generally used in desk lamps, etc.
- : For shooting under a cool white fluorescent lamp (4200K)*. This type of lamp is generally used in offices, etc.
- : For shooting under a white fluorescent lamp (3500K)*.
- : For shooting under a tungsten light (3000K)*.

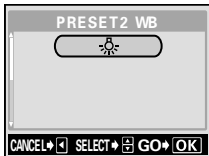

* The color temperature values (K) are approximate. They are not an accurate indication of color.



TIPS

- You can also preview different color tones by trying the different PRESET WB settings under the actual light source and checking the result on the monitor.

Custom white balance

This function lets you select a white balance saved in the CUSTOM WB settings. Press to select CUSTOM 1, CUSTOM 2, CUSTOM 3 or CUSTOM 4, then press . Press again to exit the menu.

If no custom white balance has been saved, the item is displayed in gray and cannot be selected.

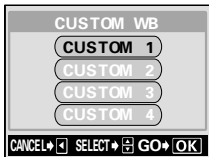

"Saving a custom white balance" in next section.

● Saving a custom white balance

You can register the current white balance setting and white balance adjustment value in CUSTOM 1 - CUSTOM 4 and select them as white balance custom menus.



- 1 In the top menu, select **MODE MENU** → **PICTURE** → **CUSTOM WB** → **CUSTOM 1**, **CUSTOM 2**, **CUSTOM 3** or **CUSTOM 4**, and press .

"How to use the menus" (P.70)

- The current white balance setting and white balance adjustment value are saved as CUSTOM WB.
- If a custom white balance is already saved in the selected number, a confirmation screen appears. To register the new settings, select CANCEL and press .
- Press again to exit the menu.

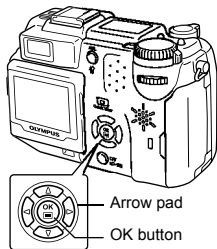

One-touch white balance



This function is useful when you need a more precise white balance than PRESET WB can provide. To set the optimum white balance for the shooting conditions, point the camera at a white object under the light source you want to use and adjust the white balance.

1 Display screen and point the camera at a sheet of white paper.

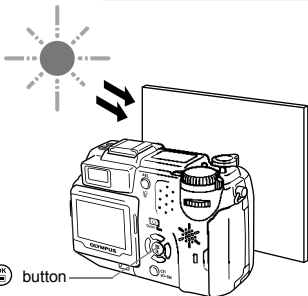
- Position the paper so that it fills the screen, making sure there are no shadows.



2 Press .

- The white balance is set.
- To cancel one-touch white balance, press .
- Press  repeatedly to exit the menu.



One-touch white balance



Note

- When setting the white balance by pointing the camera at a sheet of white paper, the correct setting may not be obtained if the light reflected by the paper is too bright or too dark.
- White balance may not be effective under some special light sources.
- After setting a white balance other than AUTO, play back the picture and check the colors on the monitor.
- When the flash is fired with a white balance setting other than AUTO, colors may appear different in the resulting picture from the colors you see on the monitor.

White balance adjustment



This function lets you make fine changes to the AUTO, PRESET 1, PRESET 2 and white balance settings.

Mode dial

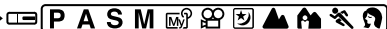

- 1 In the top menu, select **MODE MENU** → **PICTURE** → , and press .

"How to use the menus" (P.70)

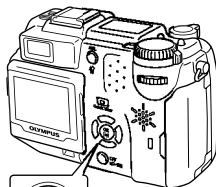

Arrow pad

OK button

- 2 Press to select **AUTO**, **PRESET 1**, **PRESET 2** or , then press .

- The white balance adjustment indicator appears on the screen.

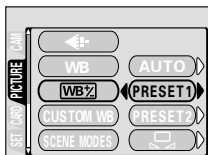

- 3 The color becomes bluer each time you press , and redder each time you press , depending on the original white balance conditions. Press to save your adjustment.

- The white balance can be adjusted 7 increments in both red and blue directions.
- After saving the adjustment, press again to exit the menu.



Sharpness

This function adjusts the sharpness of the image.



- 1 In the top menu, select **MODE MENU** → **PICTURE** → **SHARPNESS**, and press .

"How to use the menus" (P.70)

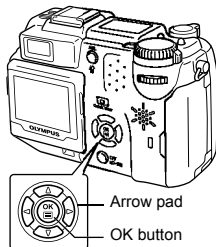

- 2 Press to adjust the sharpness between **+5** and **-5**.

- To increase the sharpness (+) :
Press . The image contours are emphasized, making the image appear sharper and more vivid. Use this setting when you want to print pictures.
- To reduce the sharpness (-) :
Press . The image contours are softened. Use this setting when you want to edit images on a PC.
- When you have finished setting the sharpness, press . Press again to exit the menu.

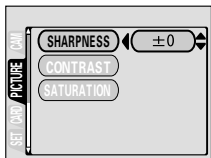

Note

- If you adjust the sharpness too far toward +, noise may become conspicuous in the picture.

Contrast

This function adjusts the contrast of images. For example, you can make images with marked differences in light and shadow softer, and those with less differences more vivid.



Mode dial



P A S M       

- 1 In the top menu, select **MODE MENU** → **PICTURE** → **CONTRAST**, and press .



 "How to use the menus" (P.70)

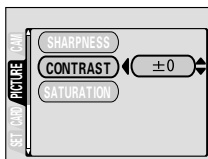

- 2 Press   to adjust the contrast between **+5** and **-5**.

- To increase the contrast (+) :
Press . The light and dark areas are defined more clearly, making the image look crisper.
- To reduce the contrast (-) :
Press . The light and dark areas become less defined, giving the image a softer impression. Use this setting when you want to edit images on a PC.



- When you have finished setting the contrast, press . Press  again to exit the menu.

Saturation

This function adjusts the color depth.



- 1 In the top menu, select MODE MENU → PICTURE → SATURATION, and press .**
 "How to use the menus" (P.70)

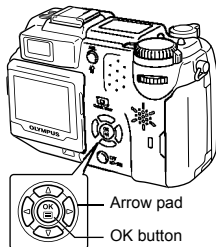

- 2 Press to adjust the saturation between +5 and -5.**

- To increase the saturation (+) :
Press . Colors become darker and more intense.
- To reduce the saturation (-) :
Press . Colors become lighter.

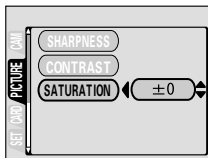



- When you have finished setting the saturation, press . Press again to exit the menu.

7





Adjusting the image quality and exposure

Scene modes

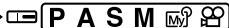
This function lets you select the image processing best suited to your purpose and the effect you want to achieve in P, A, S, M,  and  mode. The color reproduction, sharpness, contrast and saturation values are set.

Mode dial



- 1 In the top menu, select **MODE MENU** → **PICTURE** → **SCENE MODES**, then choose from **NORMAL**, ,  and , and press .

 "How to use the menus" (P.70)

- If you select ,  or , see "Situation-related modes" (P.61).
- Press  again to exit the menu.

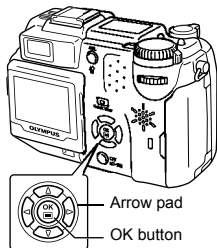

Noise reduction

7

Adjusting the image quality and exposure

This function reduces the noise that is generated during long exposures. When shooting night scenes, shutter speeds become slower and noise tends to appear on images. When noise reduction is set to ON, the camera automatically reduces noise to produce clearer images. However, shooting time is approximately twice as long as usual. Noise reduction can only be used when the shutter speed is set slower than 1 sec.



Noise reduction: OFF





Noise Reduction: ON

The purpose of these pictures is to illustrate the effects of noise reduction. They are not actual pictures.





Mode dial  **P A S M** 

- 1 In the top menu, select **MODE MENU** → **CAMERA** → **NOISE REDUCTION** → **ON** or **OFF**, and press .

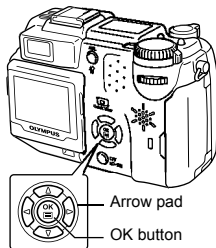
 "How to use the menus" (P.70)

- Press  again to exit the menu.
- When noise reduction is set to ON, NR is displayed on the control panel.



- Noise reduction is always enabled in the  mode.
- When noise reduction is set to ON, the camera implements noise-reducing processes after each shot.
- When noise reduction is set to ON, sequential shooting (**HI** , , **AF** , BKT) is not possible.
- This function may not work effectively with some shooting conditions or subjects.
- As the shutter speed is relatively slow, the use of a tripod is recommended.

Histogram display



This function lets you display a histogram during shooting or playback. During shooting, you can display a histogram showing the brightness and contrast of your subject in the monitor. Checking the histogram enables precise exposure control. During playback, you can display a histogram showing the brightness and contrast of recorded pictures. The histogram display can be set separately for shooting mode and playback mode.

Ex: When a histogram is displayed in P mode

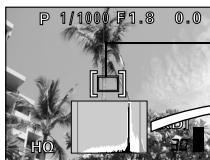

Histogram target mark

The part indicated in green in the histogram shows the luminance distribution within the histogram target mark.

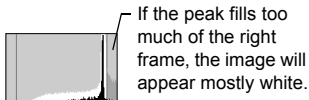
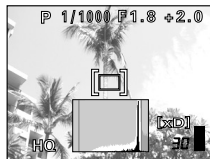

When the image is bright

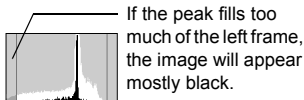
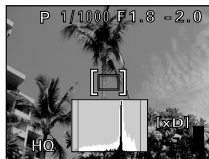

When the image is dark





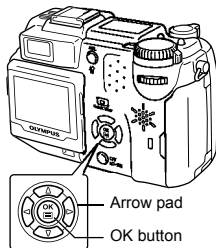

- 1 In the top menu, select **MODE MENU** → **CAMERA** → , then choose the histogram display method and press .

 "How to use the menus" (P.70)



OFF : The histogram is not displayed.

 ON : The histogram is displayed when  is pressed.  "Exposure compensation" (P.131)

ON : The histogram is always displayed.

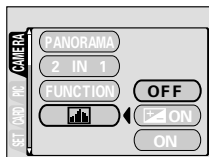



- Press  again to exit the menu.
- When ON is selected, the monitor turns on automatically and the histogram is displayed.



Press  in the top menu.

 "How to use the menus" (P.70)

- The histogram is displayed.
- To return to the normal playback screen, press  again to display the top menu and press .

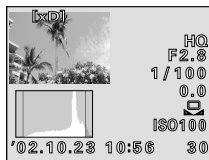



Note

- The histogram is not displayed in the following situations even if histogram display is set to ON.

In movie mode, during panorama shooting, during 2 in 1 shooting, during Rec View, during multi-metering

- You can turn the histogram display on and off during exposure compensation. “Exposure compensation” (P.131)

● Changing the position of the histogram target mark

While the histogram is displayed in shooting mode, hold down and use the arrow pad to move the histogram target mark. The area inside the target is displayed in green on the histogram.

To restore the histogram target mark to its original position, press .

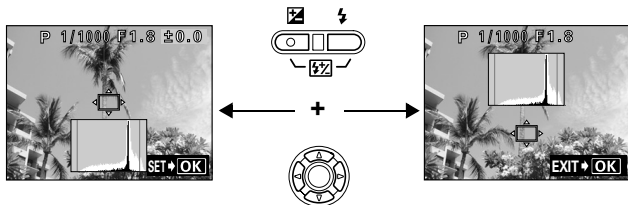

7

Adjusting the image quality
and exposure

8 Playback

Close-up playback



Pictures displayed on the monitor can be enlarged 1.5, 2, 2.5, 3, 3.5 or 4 times.

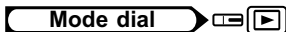

1 Select the still picture you want to enlarge.

- You cannot enlarge pictures with .

2 Turn the zoom lever toward T.

- By using the arrow pad while the enlarged picture is displayed, you can shift the picture in the desired direction, enabling you to view a different portion.
- Turning the jog dial allows you to view the next or previous frame in the same magnification.
- To return the picture to the original size (1x), turn the zoom lever toward W.

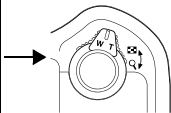
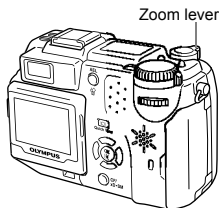

Note

- Pictures cannot be stored in an enlarged state.

Index display



This function lets you show several pictures at the same time on the monitor. The number of pictures shown can be 4, 9 or 16. “Selecting the number of pictures” (P.149)

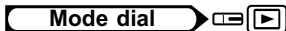

- 1** In the single-frame playback mode, turn the zoom lever toward W.

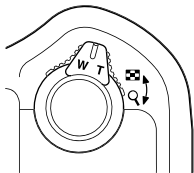

- Use the arrow pad to select the picture.

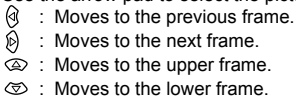

- Turning the jog dial during an index display allows you to scroll to the next or previous index display.

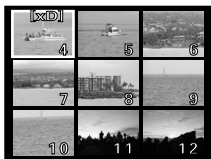
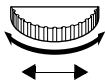

- To return to the single-frame playback, turn the zoom lever toward T.

Selecting the number of pictures



This function lets you select the number of pictures in an index display from 4, 9 and 16.

Mode dial

- In the top menu, select **MODE MENU** → **SETUP** → .

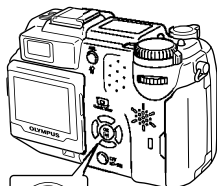
 "How to use the menus" (P.70)



- Choose the number of pictures (**4**, **9** or **16**) and press .
 - Press  again to exit the menu.

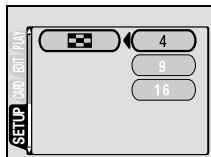







This function displays still pictures stored in the card one after another. Only the first frame of movies is played back.

Mode dial



- 1 Select a still picture, then press  to display the top menu.
- 2 Press  to start the slideshow.
- 3 Press  to stop the slideshow.
 - The slideshow will not stop until you cancel it by pressing .

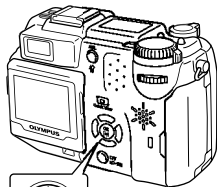

Arrow pad

OK button



Note

- You are recommended to use the optional AC adapter when running a slideshow for a long period of time. If batteries are used, the camera will stop the slideshow after about 30 minutes and enter sleep mode.

Playback on a TV

Use the AV cable provided with the camera to play back recorded images on your TV.

Mode dial



- 1 Make sure that the TV and camera are turned off. Connect the A/V OUT jack on the camera to the Video input terminal on the TV using the AV cable.**

Connect to the TV's video input (yellow) and audio input (white) terminals.

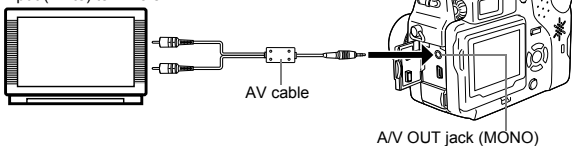

- 2 Turn the TV on and set it to the video input mode.**
 - For details of switching to video input, refer to your TV's instruction manual.
- 3 Turn the camera on and set the mode dial to .**
 - The last picture taken is displayed on the TV. Use the arrow pad to select the picture you want to display.
 - The close-up playback, index display and slideshow functions can also be used on a TV screen.

TIPS



- You are recommended to use the optional AC adapter when using the camera with a TV.



Note

- Make sure that the camera's video output signal type is the same as the TV's video signal type.  "Video output selection" (P.192)
- The camera's monitor turns off automatically when the AV cable is connected to the camera.
- Be sure to use the AV cable provided to connect the camera to the TV.
- The picture may appear off-center on the TV screen.
- When pictures are compressed in order to fit the entire picture on the TV screen, a black frame appears around the picture. If the picture is output to a video printer via the TV, the black frame may be printed.

Picture rotation

Pictures taken with the camera held vertically are displayed horizontally. This function lets you turn such pictures 90 degrees clockwise or counterclockwise so that they are displayed vertically.

Mode dial

1 In the single-frame playback mode, press .

- Each pressing  rotates the image in the following sequence: 90 degrees counterclockwise, 90 degrees clockwise, and back to the original.

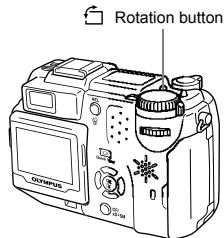

- The following pictures cannot be rotated.
Movies, protected pictures, pictures that have been edited on a PC, pictures taken with another camera, and pictures stored on a write-protected card.
- New picture orientations are saved even when the power is turned off.
- Close-up playback is possible after a picture has been rotated, but pictures cannot be rotated while in close-up playback.

Recording sound



Sound can be added to a still picture that you have already taken. (This is known as “after-recording”.) You can also re-record over the sound that has already been recorded. Total recording time per picture is approximately 4 seconds.

Mode dial



- 1 Use the arrow pad to select the still picture you want to add sound to.
- 2 In the top menu, select **MODE MENU** → **PLAY** → .
 “How to use the menus” (P.70)

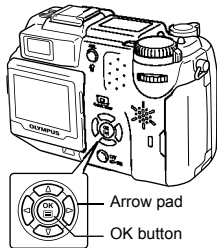

- 3 Press to display **START**.
- 4 Turn the camera microphone toward the sound you want to record and press to start recording.

- The busy bar is displayed during recording.

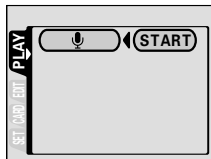



Note

- To obtain the optimum sound, the microphone should be placed no farther than 1 m (3.3 ft.) away from the subject.
- If you re-record the sound, the original sound is erased.
- You may not be able to record sound when there is insufficient card memory (the CARD FULL message is displayed).
- Sound recording may pick up camera noises, such as button operation or shutter movement.
- Once sound is added to a picture, it is not possible to erase only the sound. In this case, make a re-recording with silence.

Editing still pictures

This function lets you edit still pictures and store them as new pictures. The following editing operations are possible.

- Resizing  : Changes the picture size to 640 × 480 or 320 × 240 and stores the picture as a new file.
- Trimming  : Crops part of a picture and saves it as a new file.
- RAW DATA EDIT : Adjusts the white balance, sharpness, etc. of the pictures recorded in the RAW data format and stores them as new TIFF or JPEG files. You can edit recorded pictures to your liking while checking the result.

Mode dial







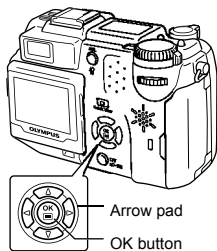

- 1 Use the arrow pad to select the still picture you want to edit.
- 2 In the top menu, select **MODE MENU** → **EDIT**, then choose each item.

 "How to use the menus" (P.70)

- Select   This page
- Select   P.155
- Select RAW DATA EDIT  P.156



Resizing

- 3 Select , then press .
- 4 Press   to select the new picture size, then press  .
 - The busy bar is displayed during resizing. After the image is saved, the camera returns to the mode menu.
 - To quit the resizing function, select **CANCEL**, then press .

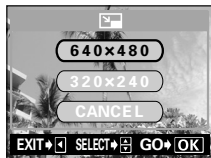

When there are two types of card in the camera, the card selection screen appears after step 4. Use the arrow pad to select the card and press .

When there is insufficient card memory, the display returns to the setting screen.



Note

- Resizing is not possible in the following cases.
 - Movies, pictures that have been edited on a PC, or when there is insufficient memory space on the card.
 - If the size of the selected picture is 640×480 , you cannot select 640×480 .

Trimming

- Select , then press
- Press to select NEW FILE, then press .
- Use the arrow pad, zoom lever and jog dial to decide the trimming position and size.
 - Press to move the trimming frame, and turn the zoom lever toward W or T to decide the size.
 - Use the jog dial to select the height and width of the trimming frame.
 - 3:2 trimming size can be selected when the size of the selected picture is 2560×1920 , or 2560×1696 .
- Press .
 - The trimmed picture is displayed for one second.





8

Playback

7 Press to select OK, then press .

- The busy bar is displayed during resizing. After the image is saved, the camera returns to the mode menu.
- The trimmed picture is stored as a separate picture from the original.



- If you want to trim the picture again, select RESET and press  and repeat the procedure from Step 5.
- To quit the trimming function, select CANCEL and press .

When there are two types of card in the camera, the card selection screen appears after step 6. Use the arrow pad to select the card and press .

When there is insufficient card memory, the display returns to the setting screen.



Note

- Trimming is not possible in the following cases.
 - Movies, when there is insufficient memory space on the card, or when the picture was taken with the record mode set to ENLARGE SIZE.
 - It may not be possible to trim pictures taken with another camera.
 - If pictures recorded in 3:2 are trimmed, the image proportions are changed to the standard 4:3 aspect ratio.
 - If a trimmed picture is printed out, it may appear grainy.

8

RAW editing

3 Select RAW DATA EDIT, then press .

4 Press to select the item you want to set, then press .

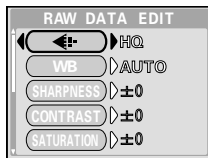

5 Press to select the desired setting, then press .

6 When all the necessary items have been set, press .

- The busy bar is displayed during resizing. After the image is saved, the camera returns to the mode menu.

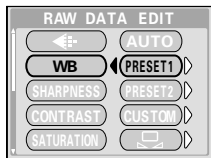

When there are two types of card in the camera, the card selection screen appears after step 6. Use the arrow pad to select the card and press .

When there is insufficient card memory, the display returns to the setting screen.

● Items that can be set by RAW editing

Item	Settings	Ref. Page
	TIFF, SHQ, HQ, SQ1, SQ2	P.125
WB	PRESET1, PRESET2, CUSTOM,	P.133
SHARPNESS	±5	P.139
CONTRAST	±5	P.140
SATURATION	±5	P.141
FUNCTION	OFF, BLACK & WHITE, SEPIA	P.121
	—	P.155

Editing movies

This function lets you create indexes from as well as edit movies. You cannot edit movies longer than approximately 32 seconds in HQ mode and approximately 130 seconds in SQ mode.

INDEX : 9 frames extracted from a movie are displayed as an index to show the movie at a glance. Indexes can be stored on the card as a still picture.

EDIT : This function lets you erase parts of the movie that you do not want.

Mode dial



- 1 Use the arrow pad to select a picture with .



- 2 In the top menu, select **MOVIE PLAY**, then choose each item.

"How to use the menus" (P.70)
"Viewing movies" (P.55)

- Creating an index P.158
- Editing a movie P.160



Creating an index

- 3 Press to select **INDEX**, then press .



4 Select the first frame of the index.

- Press to play back the movie until the picture that you want as the first frame is displayed in the green frame, then press .



5 Select the last frame of the index.

- As in Step 4, press to play back the movie until the picture that you want as the last frame is displayed in the green frame, then press .

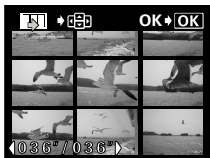

6 Press to select OK, then press .

- The 9 frames extracted from the movie appear as an index display, then the camera returns to the playback mode. The index is stored as a new picture.
- If you want to select different frames, select RESET and press and repeat the procedure from Step 4.
- To quit the index function, select CANCEL and press .



When there are two types of card in the camera, the card selection screen appears after step 5. Use the arrow pad to select the card and press .
When there is insufficient card memory, the display returns to the setting screen.



TIPS

- The index is stored as a still picture in a different record mode from the original movie.



Record mode when the movie was shot	Record mode when stored as an index
HQ	SQ1 (1024 × 768 pixels: HIGH)
SQ	SQ2 (640 × 480 pixels: HIGH)





Note

- The interval between the frames that are automatically picked out varies depending on the length of the movie.
- An index consists of 9 frames.
- You cannot edit movies stored on a write-protected card.
- You cannot create an index if there is insufficient memory space on the card.



Editing a movie

3 Press   to select EDIT, then press .



4 Select the first frame of the part you want to keep.

- Press   to play back the movie, and when the frame that you want as the first frame is displayed, press .

5 Select the last frame of the part you want to keep.

- As in Step 4, press   to play back the movie, and when the frame that you want as the last frame is displayed, press .

6 Press   to select OK, then press .

- If you want to select different frames, select RESET and press  and repeat the procedure from Step 4.
- To quit the editing function, select CANCEL and press .



7 Press to select **NEW FILE** or **OVERWRITE**, then press .

NEW FILE : Stores the edited movie as a new movie with a different name.

OVERWRITE : Stores the edited movie with the same name as the original. The original movie is not stored.



- The edited movie is stored and the screen returns to the playback mode.

When there are two types of card in the camera, the card selection screen appears after step 5. Use the arrow pad to select the card and press .

When there is insufficient card memory, the display returns to the setting screen.



Note

- You cannot edit movies with sound which were taken with another digital camera.
- You cannot select NEW FILE if there is insufficient memory space on the card.

Copying pictures

This function lets you copy pictures to and from the xD-Picture Card/SmartMedia and the Compact Flash/Microdrive. This menu can be selected if both cards are inserted.

The selected card is the copying source. You can change the copying source by pressing card button.

☞ "Switching cards" (P.29)

ALL : Copies all the pictures on the card.

SELECT : Copies only the selected picture.

Mode dial

- 1 In the top menu, select **MODE MENU** → **EDIT** → **COPY**, and press .

☞ "How to use the menus" (P.70)

- The screen is displayed for you to select ALL or SELECT.

- 2 Press   to select **ALL** or **SELECT**, then press .

● If you choose **ALL**

A confirmation screen appears asking if you want to copy the pictures. Select YES and press . The pictures are copied and the menu is exited.

● If you choose **SELECT**

The playback screen is displayed. Turn the jog dial to select the frame you want to copy and press .

The picture is copied.

If you want to copy more pictures, repeat the procedure.

To finish copying, press .

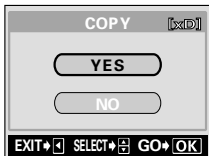
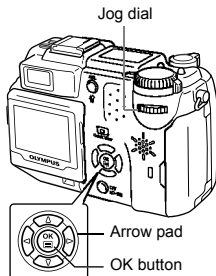

 • Pictures cannot be copied to the same card.

Note

All-frame erase



This function erases all the pictures on the card.

Mode dial



- 1 In the top menu, select **MODE MENU** → **CARD** → **CARD SETUP**, and press .

"How to use the menus" (P.70)

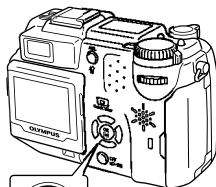

- 2 Press to select **ALL ERASE**, then press .

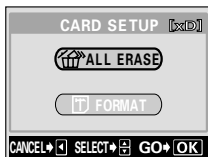

- 3 Press to select **YES**, then press



- All the pictures are erased.



9 Useful functions

All Reset - Saving the camera's settings

This function lets you choose whether or not to save the current camera settings after the power is turned off. The settings affected by All Reset are listed on the next page.

The All Reset setting (ON/OFF) applies to all the modes. If All Reset is set to OFF in one shooting mode, this setting applies to all the other modes, both shooting and playback.

ON : All settings are returned to the factory default settings after the power is turned off.

OFF : The settings made before the power is turned off are saved.



- 1 In the top menu, select MODE MENU → SETUP → ALL RESET → OFF or ON, and press .**

"How to use the menus" (P.70)



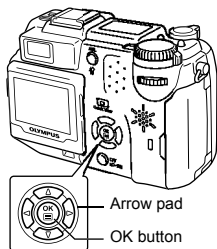











- Press again to exit the menu.



Note

- My Mode settings and the settings in the SETUP menu are saved even when All Reset is set to ON.

● Functions that All Reset affects

Function	Factory default setting	Ref. Page	Function	Factory default setting	Ref. Page
FNo	F1.8	P.91	FULLTIME AF	OFF	P.97
SHUTTER	1/1000	P.92	AF MODE	iESP	P.96
	±0	P.131		OFF	P.122
FLASH MODE	AUTO	P.79	FUNCTION	OFF	P.121
	±0	P.85		OFF	P.144
AF /  / MF	AF	P.100, 107, 108		HQ	P.125
METERING	ESP	P.102	WB	AUTO	P.133
 / 	OFF	P.109, 110		±0	P.138
LCD	OFF	—	SCENE MODES	NORMAL	P.142
xD•SM/CF	xD•SM	P.29	SHARPNESS	±0	P.139
OPTICAL ZOOM	WIDE	P.50	CONTRAST	±0	P.140
DRIVE		P.112	SATURATION	±0	P.141
BKT	±1, x3	P.113	TIFF	2560×1920	P.126
ISO	AUTO	P.130	SHQ, HQ	2560×1920	P.126
 FLASH	IN+ 	P.86	SQ1	1600×1200 NORMAL	P.126
SLAVE	1	P.90	SQ2	640×480 NORMAL	P.126
 SLOW	 SLOW 1	P.84	INFO	OFF	P.177
NOISE REDUCTION	OFF	P.142		640 × 480	P.154
DIGITAL ZOOM	OFF	P.51			

Custom button



You can set frequently used functions on the custom button. This makes it easy to jump to the SETUP screen without selecting MODE MENU or a shortcut menu in the top menu.

Selecting a setting with the jog dial and pressing displays a dedicated screen for that setting. You can make fine settings using the arrow pad and .

Custom button

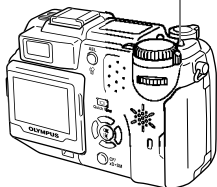

Functions that can be set on the custom button	Settings made by the jog dial	Ref. Page
DRIVE (factory default setting)	, HI , , AF , BKT*	P.112
ISO	AUTO, 64, 100, 200, 400	P.130
MY MODE*	1, 2, 3, 4, 5, 6, 7, 8	P.95
NOISE REDUCTION	OFF, ON	P.142
DIGITAL ZOOM	OFF, ON	P.51
FULLTIME AF	OFF, ON	P.97
	OFF, ON	P.122
FUNCTION	OFF, BLACK & WHITE, SEPIA, WHITE BOARD, BLACK BOARD	P.121
	HQ* , SQ1* , SQ2* , RAW, TIFF* , SHQ*	P.125
WB	AUTO, PRESET 1* , PRESET 2* , CUSTOM* ,	P.133
SCENE MODES	NORMAL, , ,	P.142
SHARPNESS	-5 - ±0 - +5	P.139
CONTRAST	-5 - ±0 - +5	P.140
SATURATION	-5 - ±0 - +5	P.141

*The sub-menu lets you select further options.

Setting the custom button



- 1 In the top menu, select **MODE MENU** → **SETUP** → **CUSTOM BUTTON**, and press .

"How to use the menus" (P.70)

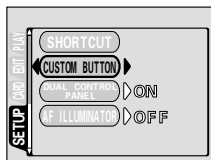
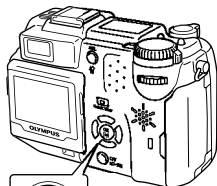

- 2 Press to select the function you want to set, then press .

• Press again to exit the menu.



Note

- If the mode dial is set to a mode other than and is pressed when MY MODE is set on the custom button, the customized setting is not activated. Set the mode dial to and press to display the MY MODE screen.

Using the custom button



1 Press .



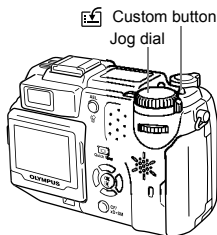

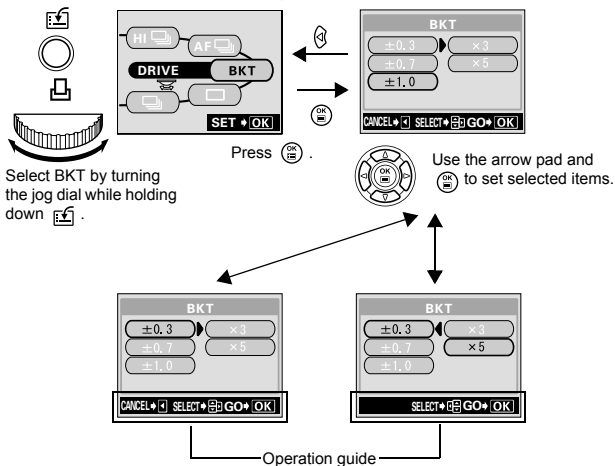

- The monitor turns on and the function currently set to the custom button appears.



Ex: When DRIVE is set on the custom button
Set BKT. Follow the operation guides displayed at the bottom of the screen to complete the setting.



Shortcut

You can set three shortcut menus (A, B, C) on the top menu in a still picture shooting mode (P, A, S, M, , , , , , , ).

This is useful when you want to go quickly to frequently-used functions.

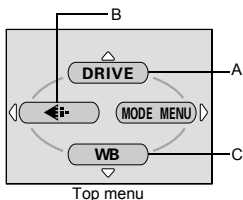







The default settings are

A: DRIVE

B: 

C: WB

Functions that can be set in the shortcut menu	Ref. Page	Functions that can be set in the shortcut menu	Ref. Page
DRIVE	P.112	2 IN 1	P.119
ISO	P.130	FUNCTION	P.121
MY MODE	P.95		P.144
 FLASH	P.86		P.125
 SLOW	P.84	WB	P.133
NOISE REDUCTION	P.142		P.138
DIGITAL ZOOM	P.51	CUSTOM WB	P.135
FULLTIME AF	P.97	SCENE MODES	P.142
AF MODE	P.96	SHARPNESS	P.139
	P.122	CONTRAST	P.140
PANORAMA	P.116	SATURATION	P.141

Setting the shortcut menu

You can set the three shortcut menus designated by A, B and C on the diagram shown right.

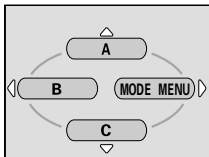

Mode dial



- 1 In the top menu, select **MODE MENU** → **SETUP** → **SHORT CUT**, and press .

"How to use the menus" (P.70)

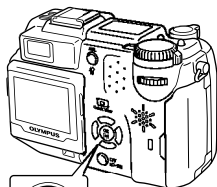

- 2 Press to select A, B or C, then press .

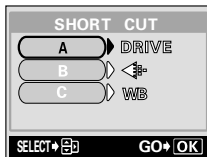

- 3 Press to select the function you want to set, then press .

- The shortcut menu is set.
- Press again to exit the menu.

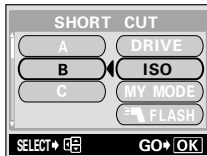

Using the shortcut menu

When you have set a shortcut menu, you can use it to jump to the setting screen for that function.



1 Press to display the top menu.

- The shortcut menu you have set appears on the top menu.

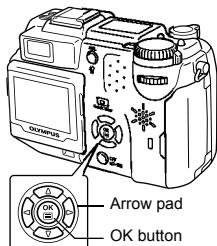

2 Press , or to select the shortcut menu.

- The monitor jumps directly to the setting screen for that function.

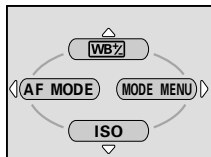

Ex: When **WB%** is set in shortcut menu A

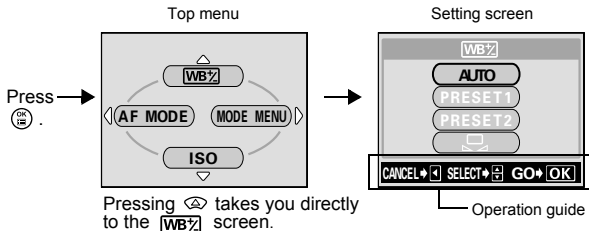

3 Follow the operation guides on the screen.















MY MODE SETUP



You can set shooting-related functions in MY MODE. When the camera is in **P**, **A**, **S**, or **M** mode, you can also save the current settings in MY MODE.

When the mode dial is set to , your customized settings are activated. You can save up to 8 different settings in MY MODE 1 to 8. Only MY MODE 1 has a factory default setting.

● Functions affected by MY MODE SETUP

Functions that can be set in MY MODE	Default setting	Ref. Page	Functions that can be set in MY MODE	Default setting	Ref. Page
P/A/S/M/S-Prg	P	P.59	NOISE REDUCTION	OFF	P.142
FNo	F1.8	P.91	DIGITAL ZOOM	OFF	P.51
SHUTTER	1/1000	P.92	FULLTIME AF	OFF	P.97
	±0	P.131	AF MODE	iESP	P.96
xD•SM/CF	xD•SM	P.29		OFF	P.122
LCD	ON	—	PANORAMA	OFF	P.116
ZOOM POSITION	35 mm	—	2 IN 1	OFF	P.119
FLASH MODE	AUTO	P.79	FUNCTION	OFF	P.121
	±0	P.85		OFF	P.144
	ESP	P.102		HQ	P.125
	OFF	P.109, 110	WB	AUTO	P.133
AF/  /MF	AF	P.100, 107, 108		±0	P.138
DRIVE		P.112	SCENE MODES	NORMAL	P.142
ISO	AUTO	P.130	SHARPNESS	±0	P.139
 FLASH	IN+ 	P.86	CONTRAST	±0	P.140
 SLOW	 SLOW 1	P.84	SATURATION	±0	P.141

Mode dial



- 1 In the top menu, select **MODE MENU** → **SETUP** → **MY MODE SETUP**, and press .

"How to use the menus" (P.70)

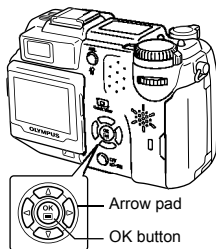

- 2 Press to select an item, then press .

PRESENT : Saves the current camera settings.

RESET : Restores the factory default settings.

CUSTOM : Saves settings one by one.

- The MY MODE SETUP screen appears.

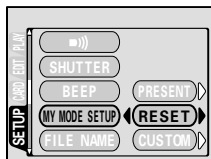

- 3 Select a **MY MODE** number.

- Press to select a MY MODE number from 1 to 8, then press .

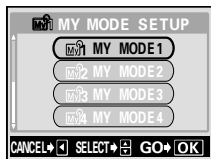

●When selecting **PRESENT** in Step 2

- 4 Press to select **SET**, then press .

- The current camera settings are saved in the selected MY MODE.

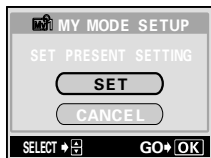

● When selecting RESET in Step 2

4 Press to select ALL RESET, then press .

- The settings in the selected MY MODE are reset.
- If no settings are saved, it cannot be selected.

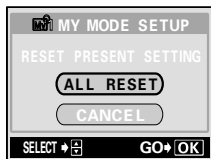

● When selecting CUSTOM in Step 2

4 Press to select the item you want to save in MY MODE, then press .

- For the available items, see "MY MODE SETUP" (P.172).

Press to change the setting, then press .

- The setting is saved.
- You can also change the other custom settings.

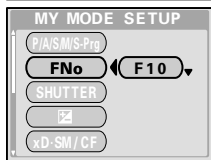
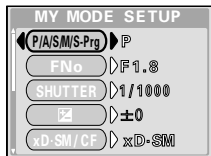

5 When you have made all the settings you want, press .

- The screen displayed in Step 2 appears.
- Press again to exit the menu.



This function lets you format a card. Formatting prepares cards to receive data. Before using non-Olympus cards or cards which have been formatted on a PC, you must format them with this camera.



- 1** In the top menu, select **MODE MENU** → **CARD** → **CARD SETUP**, and press

"How to use the menus" (P.70)

- **P A S M**
- The **FORMAT** screen is displayed.
-
- The **CARD SETUP** screen is displayed.

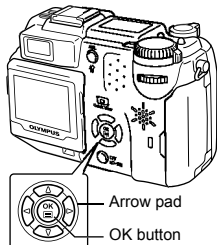

- 2** If the mode dial is set to **P A S M** , press to select **FORMAT**. If the mode dial is set to , press to select **FORMAT**, then press . The **FORMAT** screen is displayed. Press to select **YES**.

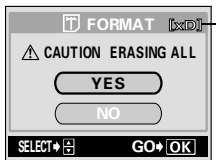

The card to be formatted is displayed.

- 3** Press .
- The busy bar is displayed and the card is formatted.







Note



- Never open the card cover or remove the batteries during formatting as this may cause the card to malfunction.
- Never connect or disconnect the AC adapter during formatting as this may cause the card to malfunction.
- If you format an OLYMPUS template card, all the template data stored on the card is erased. You are recommended to download image data stored on the template card to a PC. For more details, read the instructions provided with the template card.
- Write-protected cards cannot be formatted. Remove the write-protect seal before formatting the card. Do not reuse the write-protect seal.

This function lets you display detailed shooting information on the monitor for 3 seconds in the playback mode. For details of the information displayed, see "Monitor indications" (P.15).

Mode dial

- Pressing  in the top menu displays the full amount of shooting information on the monitor (ON).

 "How to use the menus" (P.70)

- To turn INFO off, press  to bring up the top menu and press  (OFF).

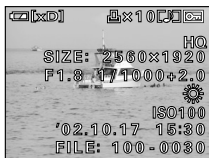
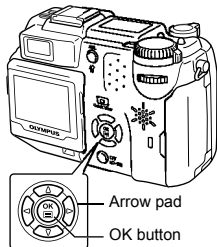

When INFO is ON



When INFO is OFF



- If the picture has been taken with a different camera, only the date, frame number and battery level are displayed when INFO is set to ON.
- If  is set, the histogram is displayed regardless of whether INFO is set to ON or OFF.

Dual control panel display

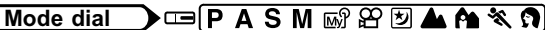

This function lets you display control panel indications more clearly on the monitor in shooting mode. Press  to switch the monitor display, when you want to view the subject or menu.

Mode dial



- 1 In the top menu, select **MODE MENU** → **SETUP** → **DUAL CONTROL PANEL** → **ON**, and press .

 "How to use the menus" (P.70)

- Press  again to exit the menu.
- The dual control panel is displayed on the monitor.  "Dual control panel screen" (next page)

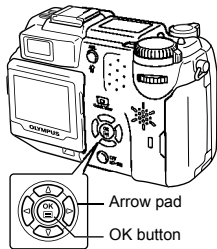

- The subject is displayed on the monitor when using functions that use the monitor such as macro shooting or digital zoom.

● Dual control panel screen

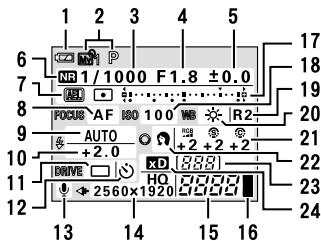

- | | | |
|----------------------------|--|-------------------------------------|
| 1 Battery check | 11 Drive | 17 Spot metering/multi-metering bar |
| 2 Shooting mode | 12 Self-timer/Remote control | 18 ISO |
| 3 Shutter speed | 13 Sound record | 19 White balance compensation |
| 4 Aperture value | 14 Record mode/number of pixels | 20 White balance |
| 5 Exposure compensation | 15 Number of storable still pictures/Seconds remaining | 21 Saturation/sharpness/contrast |
| 6 Noise reduction | 16 Memory gauge | 22 SCENE MODES |
| 7 AE lock/AE memory | | 23 Folder number |
| 8 Focus mode | | 24 Selected card |
| 9 Flash mode | | |
| 10 Flash intensity control | | |

- The dual control panel is always displayed during shooting mode.
- Pressing the direct button displays the setting in green on the dual control panel. Each setting can be made on the dual control panel by turning the jog dial.

Monitor brightness adjustment

This function lets you adjust the brightness of the monitor.

Mode dial



- 1 In the top menu, select **MODE MENU** → **SETUP** →  and press





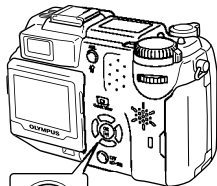



 "How to use the menus" (P.70)



Arrow pad

OK button

- 2 Press   to adjust the brightness of the monitor, and when you have set the desired level, press .

- Pressing  brightens the monitor, and pressing  darkens it.
- Press  again to exit the menu.



Rec View

You can choose whether or not to display the picture you have just taken on the monitor.

- ON** : The picture being recorded to the card is displayed. This is useful for making a brief check of the picture you have just taken. Pressing the shutter button halfway during Rec View lets you resume shooting immediately.
- OFF** : The picture being recorded to the card is not displayed. This is useful when you want to prepare for your next shot while the previous picture is being recorded.

Mode dial



- 1 In the top menu, select MODE MENU → SETUP → REC VIEW → OFF or ON, and press .**

 "How to use the menus" (P.70)

- Press  again to exit the menu.

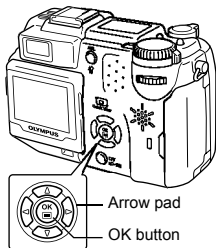

- If the batteries are running low when you take a picture with the monitor off and Rec View is set to ON, the picture may not be displayed.

Beep sound adjustment





You can select the volume of the beep sound used for warnings from OFF, LOW, or HIGH. The factory default setting is HIGH. You can turn the sound off completely by setting OFF.

Mode dial



- 1 In the top menu, select **MODE MENU** → **SETUP** → **Beep** → **OFF**, **LOW** or **HIGH**, and press .

 "How to use the menus" (P.70)

- Press  again to exit the menu.

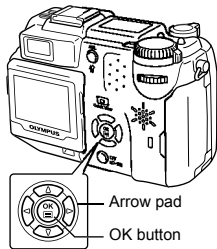

You can select from 2 kinds of sound for button operations. You can also set the volume of each kind of sound to LOW or HIGH. The factory default settings are 1 (short beep) for the kind of sound and LOW for the volume. You can turn the sound off completely by setting OFF.

Mode dial

- 1** In the top menu, select **MODE MENU** → **SETUP** → **BEEP**, and press

"How to use the menus" (P.70)

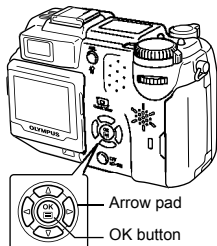

- 2** Select **1** or **2** and press . Then select **LOW** or **HIGH** and press .

- To turn off the button operation beep, select OFF and press .
- Press again to exit the menu.

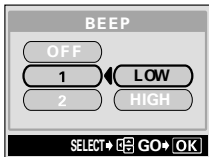

Shutter sound

You can select from 2 kinds of sound for the shutter button. You can also set the volume of each kind of sound to LOW or HIGH. The factory default settings are 1 for the kind of sound and LOW for the volume. You can turn the sound off completely by setting OFF.

Mode dial

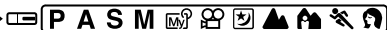

- 1 In the top menu, select **MODE MENU** → **SETUP** → **SHUTTER SOUND**, and press .

"How to use the menus" (P.70)

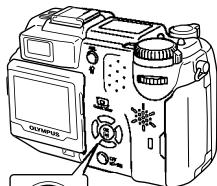

- 2 Select **1** or **2** and press . Then select **LOW** or **HIGH** and press .

 - To turn off the shutter sound, select **OFF** and press .
 - Press again to exit the menu.

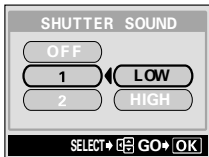

Playback volume

You can adjust the volume when playing back a still picture with sound or a movie, as well as the volume of the sound generated when the power is turned on or off. There are 5 levels to choose from. To mute the sound completely, select 0. The factory default setting is 3.

Mode dial



- 1 In the top menu, select **MODE MENU** → **SETUP** → **VOLUME**, and press .

"How to use the menus" (P.70)

- 2 Press to select the volume level, then press .

• Press again to exit the menu.

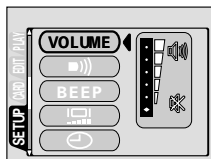

Power on/off display setting

You can select a picture and sound for when the power is turned on or off. It is also possible to register your favorite picture. “Screen setup” (P.187)

PW ON SETUP : Selects the picture and sound for when the power is turned on.

PW OFF SETUP : Selects the picture and sound for when the power is turned off.

Mode dial

P A S M

- 1 In the top menu, select **MODE MENU** → **SETUP** → **PW ON (PW OFF) SETUP**.

“How to use the menus” (P.70)

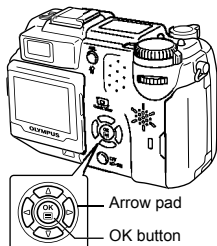

- 2 Press to select **SCREEN** and choose the screen to be displayed when the power is turned on or off. Press to select **OFF**, **1** or **2**, then press .

OFF: No picture is displayed

1 : Factory default setting

2 : Selects the picture already registered. If there is no picture registered, nothing is displayed when the power is turned on or off.

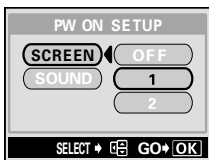

- 3 Press to select **SOUND** and choose the sound when the power is turned on or off. Press to select **OFF**, **1** or **2**, then press .

- To turn off the sound completely, select OFF.

- The volume level is the same as that set for the playback volume. “Playback volume” (P.185)

- When you have finished the settings, press .

Press repeatedly until menu disappears.

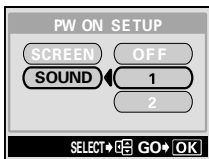

Screen setup

You can register your favorite picture to be displayed when the power is turned on or off. The desired picture can be registered from the card. Make the power on/off display setting to display the registered picture.

☞ “Power on/off display setting” (P.186)

PW ON : Registers a picture for display when the power is turned on.

PW OFF : Registers a picture for display when the power is turned off.

Mode dial



- 1 In the top menu, select **MODE MENU** → **SETUP** → **SCREEN SETUP**, and press .

☞ “How to use the menus” (P.70)

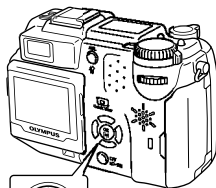

- 2 Press to select **PW ON** or **PW OFF**, then press .

- If a picture is already registered, the **IMAGE EXISTING** screen is displayed asking if you want to cancel the currently registered picture and register a new one. To register a new picture, select **RESET** and press . If you select **KEEP**, the screen returns to the **PW ON/OFF** selection screen.

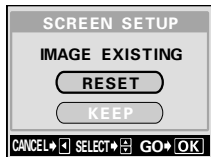
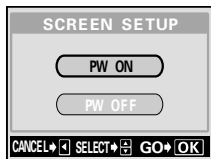

- 3 Select the picture you want to register using the arrow pad and press .

4 Press to select OK, then press .

- The picture is registered and the screen returns to Step 2. You can register other pictures.
- Press  to return to the menu.

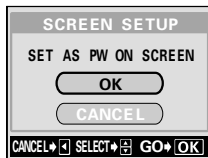

Note

- You cannot register pictures and movie frames that cannot be played back on this camera.

File name

The camera automatically creates file names and folder names for images to be stored in. Files can be numbered from 0001 to 9999 and folders can be numbered from 100 to 999. Examples are shown below.

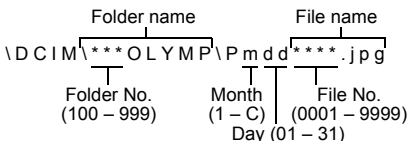

- Month: Jan. - Sep. = 1 - 9, Oct. = A, Nov. = B, Dec. = C

There are two settings from which you can choose: RESET or AUTO. Choose the one that is best for you when transferring images to a PC.

File name settings

RESET : The file number and folder number are reset every time a new card is inserted in the camera. The folder number returns to No. 100 and the file number returns to No. 0001. This method is useful when grouping files on separate cards.

AUTO : Even if a new card is inserted, the folder number and file number are retained from the previous card, so the same file number is not used on different cards. This helps you to manage multiple cards. This method is useful when you want to manage all your files with sequential numbers.

Mode dial



- 1 In the top menu, select **MODE MENU** → **SETUP** → **FILE NAME** → **RESET or AUTO**, and press

"How to use the menus" (P.70)

- Press again to exit the menu.

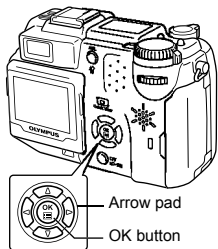

Note

- When the File No. reaches 9999, the file number returns to 0001 and the folder number changes.

- When both the Folder and File No. reach their respective maximum number (999/9999), the number of storable pictures becomes 0 even if the card is not full. No more pictures can be taken. Replace the card with a new one.

Pixel mapping

The Pixel Mapping feature allows the camera to check and adjust the CCD and image processing functions. It is not necessary to operate this function frequently. Approximately once a year is recommended. Wait a few minutes after the monitor is used or continuous shots are taken to allow for proper performance of the Pixel Mapping function.

Mode dial

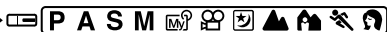

- 1 In the top menu, select **MODE MENU** → **SETUP** → **PIXEL MAPPING**, and press .

"How to use the menus" (P.70)

- 2 Press .

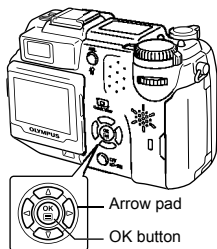

- The busy bar is displayed during Pixel Mapping. When Pixel Mapping is finished, the screen returns to the mode menu.

BUSY

9

Useful functions



- If you accidentally turn the camera off during Pixel Mapping, start again from Step 1.

The measurement unit can be selected from either meters or feet in the manual focus mode.

- m : At long ranges, the camera measures in meters, and at shorts ranges in centimeters.
- ft : At long ranges, the camera measures in feet, and at shorts ranges in inches.



- 1 In the top menu, select **MODE MENU** → **SETUP** → **m/ft** → **m** or **ft**, and press .

 "How to use the menus" (P.70)

- Press  again to exit the menu.

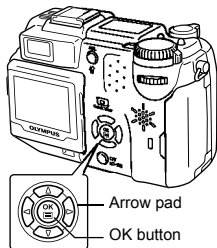

Video output selection

You can select NTSC or PAL according to your TV's video signal type. Select the video signal type before shooting. If you use the wrong video signal type, you will not be able to play back the recorded pictures properly on your TV.



- 1 In the top menu, select **MODE MENU** → **SETUP** → **VIDEO OUT** → **NTSC or PAL**, and press .

"How to use the menus" (P.70)

- Press again to exit the menu.
- The factory default setting varies depending on the area where you purchased this camera.

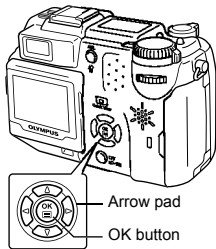

TIPS

TV video signal types & main regions

Check the video signal type before using the camera.

NTSC : Japan, Taiwan, Korea, North America

PAL : European countries, China

Initializing the settings

This function returns the settings to the factory default settings.





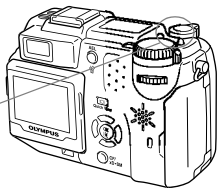
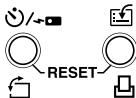



- 1 Press and at the same time for 3 seconds.



● Functions that are reset

Function	Factory default setting	Ref. Page	Function	Factory default setting	Ref. Page
FNo	F1.8	P.91	FULLTIME AF	OFF	P.97
SHUTTER	1/1000	P.92	AF MODE	SPOT	P.96
	±0	P.131		OFF	P.122
Histogram target	Center	P.146	PANORAMA	OFF	P.116
FLASH MODE	AUTO	P.79	2 IN 1	OFF	P.119
	±0	P.85	FUNCTION	OFF	P.121
AF / / MF	AF	P.100, 107, 108		OFF	P.144
AF target	Center	P.98		HQ	P.125
METERING	ESP	P.102	WB	AUTO	P.133
AEL (Multi-metering)	OFF	P.105		±0	P.138
	OFF	P.109, 110	SCENE MODES	NORMAL	P.142
LCD	OFF	—			

Function	Factory default setting	Ref. Page	Function	Factory default setting	Ref. Page
xD•SM/CF	xD•SM	P.29	SHARPNESS	±0	P.139
DRIVE		P.112	CONTRAST	±0	P.140
BKT	±1, ×3	P.113	SATURATION	±0	P.141
ISO	AUTO	P.130	TIFF	2560×1920	P.126
 FLASH	IN+ 	P.86	SHQ, HQ	2560×1920	P.126
SLAVE	1	P.90	SQ1	1600×1200 NORMAL	P.126
 SLOW	 SLOW1	P.84	SQ2	640×480 NORMAL	P.126
NOISE REDUCTION	OFF	P.142	INFO	OFF	P.177
DIGITAL ZOOM	OFF	P.51		640 × 480	P.154

10 Print setting

How to print pictures



Several different printing options are available when you want to print out pictures.

● **Printing at a photo lab that supports DPOF or printing on a DPOF-compatible printer**

Store the print reservation data on the card. Print reservation allows you to save printing data (number of prints, date/time information, etc.) with the pictures stored on the card.

What is DPOF?

DPOF is short for Digital Print Order Format. DPOF is the format used to record automatic print information from digital cameras.

If a card containing print reservation data is taken to a photo lab that supports the DPOF format, the pictures can be printed according to the DPOF reservations. Or pictures can be printed out at home on a personal DPOF-compatible printer.

● **Printing on an Olympus CAMEDIA P-400, P-330N(E) or P-200 digital printer**

By inserting a card containing print reservation data into the printer, printing is possible without using a PC. For more details, refer to the printer's instruction manual.

● **Transferring pictures to a PC and printing them from a printer connected to the PC**

If your PC has software applications installed that support JPEG images (internet browser, Paint Shop Pro, Photoshop, etc.), you can print out your pictures on a printer connected to the PC. (Printing is also possible using CAMEDIA Master software.) Check your software before printing. For details, refer to the application software's instructions.



TIPS

Picture size and printing

The resolution of a computer/printer is generally based on the number of dots (pixels) per square inch. This is called dpi (dots per inch). The higher the dpi value, the better the printed results. Keep in mind, however, that the dpi of the picture does not change. This means that when you print an image with a higher resolution, the size of the printed picture will be smaller. Although you can print magnified images, picture quality will decrease.

If you want to print large, high-quality pictures, set the record mode as high as possible when taking the pictures.

"Record mode" (P.125)



Note

- DPOF reservations set by another device cannot be changed by this camera. Make changes using the original device.
- If a card contains DPOF reservations set by another device, entering reservations using this camera may overwrite the previous reservations.
- Even if an image appears with the message "PICTURE ERROR", it may be possible to make print reservations. In this case, the print reservation icon () does not appear when an image is displayed for full view. appears when multiple images are displayed (index display), allowing you to confirm the print reservation.
- This camera cannot be directly connected to printers such as the Olympus P-300 digital printer.
- Not all functions may be available on all printers or at all photo labs.
- If you are printing using the P-330N (E), only the first 999 pictures on the card can be printed.
- Some TIFF images cannot be printed.
- Print reservation may take considerable time when saving printing data to a card.
- Print reservations cannot be made for images recorded in RAW data.

All-frame reservation



Use this feature to print all the pictures stored on the card. Select the desired number of prints and whether you want the date and time included.

Mode dial

1 Play back a still picture.

- You cannot print pictures with .



 Print button



Arrow pad

OK button

2 Press . The PRINT ORDER screen appears. Press to select ALL, then press .

- If print reservation data is already stored on the card, the  PRINT ORDER SETTING screen appears, giving you the choice of resetting the data or keeping it.  “Resetting print reservation data” (P.204)

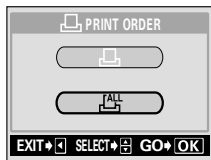

3 Press to select x (number of prints) or (date/time), then press .

4 Perform each setting as illustrated.

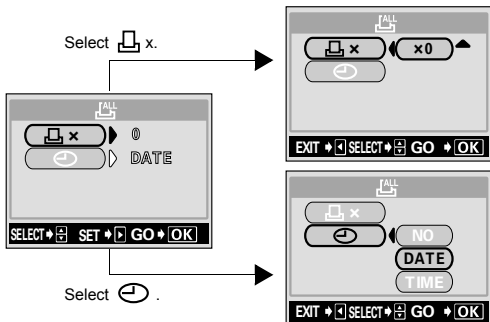

● Set the number of prints

Press to set the desired number of prints, then press .

If you want to continue to set the date/time printing data, press to return to Step 3.

: Increases the number.

: Decreases the number.

● Set the date/time printing data

Press to select NO, DATE or TIME, then press .

NO : The pictures are printed without the date and time.

DATE : All the pictures are printed with the shooting date.

TIME : All the pictures are printed with the shooting time.

- After completing all the print reservations, press to return to the playback mode menu.

Single-frame reservation



Use this feature to print only selected pictures. Display the frame to be printed and select the desired number of prints.

Mode dial



1 Play back a still picture.

- You cannot print pictures with .

Print button



Arrow pad

OK button

2 Press . The PRINT ORDER screen appears. Press to select , then press .

- If data is already stored on the card, the PRINT ORDER SETTING screen appears, giving you the choice of resetting the data or keeping it.

“Resetting print reservation data” (P.204)

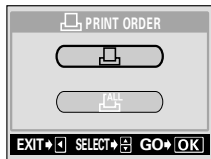

3 Select the frame you want to print using the arrow pad or the jog dial and press .



10

Print setting

4 Select the appropriate item using the arrow pad.

- MORE** : Sets the number of prints, date/time and trim size.
→Go to Step 5.
- SINGLE PRINT** : Sets single-frame print.
The date/time and trimming settings are not available.
→Go to Step 6.
- CANCEL** : Cancels the print reservation. → "Canceling reservations" (P.201)
- END** : Completes the print reservation. →Go to Step 7.



5 Press on the arrow pad to select x (number of prints), (date/time) or (trimming), then press .



6 Perform each setting.

●Set the number of prints

Press to set the desired number of prints, then press .

If you want to continue to set the date/time printing data and/or trim the pictures, press to return to Step 5.

: Increases the number.

: Decreases the number.



10

●Set the date/time printing data

Press to select NO, DATE or TIME, then press .

NO : The pictures are printed without the date and time.

DATE : All the pictures are printed with the shooting date.

TIME : All the pictures are printed with the shooting time.

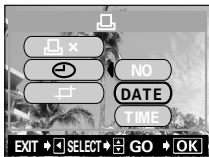

● Trim the picture

"Trimming" (P.202)

After completing all the print reservations, press to return to the screen in Step 3.

7 Press to display the single-frame reservation menu.

8 Press to select END.

- The PRINT ORDER screen appears.
- Press again to display the PRINT ORDER SETTING screen, then press once more to return to the playback mode menu. If no print reservations have been made, the PRINT ORDER SETTING screen will not be displayed.

Canceling reservations

Selecting CANCEL in Step 4 displays the selection screen for the frame to be cancelled.



1 Select the print reservation frame you want to cancel and press .

2 The screen shown above is displayed. Press to select END.

- The PRINT ORDER screen appears.
- Press again to display the PRINT ORDER SETTING screen, then press once more to return to the playback mode menu. If no print reservations have been made, the PRINT ORDER SETTING screen will not be displayed.



This function enables you to crop part of a recorded picture and print out the enlarged section only.

Mode dial

- 1 Press on the single-frame reservation screen to select (trimming) and press .

"Single-frame reservation" (P.199)

- 2 Press to select SETUP, then press .

- If trimming has already been set, the screen appears. Press to select RESET, then press .



OK : Saves the current trimming size and returns to the single-frame reservation screen.

RESET : Sets a new trimming size. →Go to Step 3.

CANCEL : Cancels the current trimming setting and returns to the single-frame reservation screen.

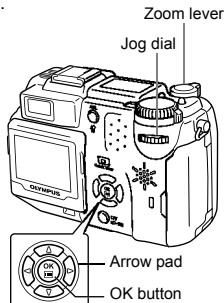

- 3 Use the arrow pad, zoom lever, and jog dial to decide the trimming position and size.

- Press to select the trimming frame, and press the zoom lever toward W or T to decide the trimming size.
- Use the jog dial to select the height and width of the trimming frame.



- 4 Press .
 - The trimmed picture is displayed for one second.



5 Press to select OK, then press .

- The busy bar is displayed during trimming, then the camera returns to the single-frame reservation screen.
- If you want to trim the picture again, select RESET and press  and repeat the procedure from Step 3.
- To quit the trimming function, select CANCEL and press .



6 Press to complete the print reservations and return to the picture selection screen. Press again.

7 Press to select END.

- To return to the  PRINT ORDER screen, press  again.



Note

- The size of the printed picture varies depending on the printer settings. If the trimmed picture size is small, printing magnification increases accordingly, resulting in a printed picture with lower resolution.
- For best results with close-up prints, you are recommended to use the TIFF, SHQ or HQ mode.
- The original picture is not trimmed. If your printer does not have the DPOF function, the picture will be printed untrimmed.
- Do not rotate pictures that have been trimmed, otherwise the cropped area will change.
- The vertical to horizontal ratio in the trimming screen can be changed using the arrow pad, but if the zoom lever is used, the ratio is fixed at 4:3. If images recorded in 3:2 are trimmed, the ratio is also fixed at 4:3.

Resetting print reservation data



This function allows you to reset all the print reservation data for pictures stored on the card.

Mode dial

1 Play back a still picture.

- You cannot print pictures with

2 Press

- If print reservation data is already stored on the card, the PRINT ORDER SETTING screen appears.

3 Press to select RESET, then press .

- If there is no print reservation data stored on the card, the PRINT ORDER SETTING screen does not appear.
- The PRINT ORDER screen appears. To quit the print reservation, press to return to the playback mode menu.



TIPS

To cancel the print reservations for selected pictures only

Select KEEP, then press .



The screen in Step 2 of Single-frame reservation (P.199) is displayed.

Follow Steps 2 and 3. In Step 4, select CANCEL.

11 Miscellaneous

Error codes

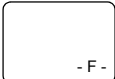
Control panel	Monitor indication	Possible cause	Corrective action
	 NO CARD	The card is not inserted, or it cannot be recognized.	Insert a card or insert a different card.
	 CARD ERROR	Cannot record, play back or erase pictures on this card.	Wipe the gold contacts with a commercially available cleaning paper and insert the card again. If the problem persists, format the card. If the card cannot be formatted, it cannot be used.
	 WRITE-PROTECT	Writing to the card is prohibited.	Remove the write-protect seal attached to the card. For details, refer to the instruction manual provided with the card.
	 CARD FULL	The card is full. No more pictures can be taken or no more information such as print reservation can be recorded.	Replace the card or erase unwanted pictures. Before erasing, download important images to a PC.
	 NO PICTURE	There are no pictures on the card.	The card contains no pictures. Record pictures.
No indication	 PICTURE ERROR	The selected picture cannot be played back on this camera.	Use image processing software to view the picture on a PC. If that cannot be done, the image file is damaged.
	 CARD COVER OPEN	The card cover is open.	Close the card cover.

		<p>The card is not formatted.</p>	<p>Format the card.</p>
---	---	-----------------------------------	-------------------------

Troubleshooting

● The camera does not work

The camera does not turn on or function buttons do not respond.

Possible cause	Corrective action	Ref. Page
The power is off.	Turn the power on.	P.31
The batteries are loaded incorrectly.	Reload the batteries correctly.	P.21
The batteries are exhausted.	Replace the batteries with new ones.	P.18
The batteries are temporarily unable to function because of the cold.	Warm the batteries by putting them in your pocket for a while.	—
The camera is in the sleep mode.	Operate the camera (press the shutter button or the zoom lever).	P.32
There is condensation* inside the camera.	Wait until the camera dries before turning it on again.	—
The camera is connected to a PC.	The camera will not operate while it is connected to a PC.	—





*Condensation: When it is cold outside, the water vapor in the air is rapidly cooled and turns to droplets of water.

Condensation occurs when the camera is suddenly taken from a cold place into a warm room.

No picture is taken when the shutter button is pressed.

Possible cause	Corrective action	Ref. Page
The camera is in the playback mode.	Set the mode dial to any position except  .	P.40
The flash has not finished charging.	Remove your finger from the shutter button, and wait until the orange lamp stops blinking. Press the shutter button again.	P.80
The card is full.	Erase unwanted pictures or insert a new card. Before erasing, download important images to a PC.	P.58, 163, 175
The batteries ran out of power during shooting or while the images were being written to the card. (Only the battery check indicator on the control panel blinks.)	Replace the batteries with new ones. (If images are being recorded on the card, wait until recording is finished.)	P.21
The memory gauge on the monitor is full.	Wait until there is room in the memory gauge.	P.18

A write-protect seal is attached to the SmartMedia card.	Insert a new card or remove the write-protect seal.	P.25
There is a problem with the card.	Refer to the "Error codes".	P.205

The flash does not fire.		
Possible cause	Corrective action	Ref. Page
The flash is set to the flash off mode.	Select a flash mode other than flash off.	P.79
The subject is illuminated.	If you want the flash to fire on a brightly illuminated subject, set the flash to fill-in mode.	P.79
Sequential shooting (HI  ,  , AF  , BKT) is set.	The flash does not fire in the sequential shooting mode. Set  in the DRIVE menu.	P.112
The camera is in the movie mode.	The flash does not fire in the movie mode. Set a different shooting mode.	P.48
FUNCTION is set to BLACK/WHITE BOARD.	The flash does not fire in the BLACK/WHITE BOARD mode.	P.121
Super macro mode is set.	The flash does not fire in the super macro mode. Set the super macro mode to OFF.	P.108
Panorama mode is set.	The flash does not fire in the panorama mode. Cancel the panorama mode.	P.116

The green and orange lamps on the right of the viewfinder blink simultaneously.		
Possible cause	Corrective action	Ref. Page
The batteries are exhausted.	Replace the batteries with new ones.	P.21

The monitor does not turn on.		
Possible cause	Corrective action	Ref. Page
The camera is in the sleep mode.	Operate the camera (press the shutter button or the zoom lever).	P.31



The viewfinder display is not clear.

Possible cause	Corrective action	Ref. Page
The diopter is not adjusted properly.	Adjust the diopter so that the AF target mark is clearly visible.	P.38

The monitor is hard to see.

Possible cause	Corrective action	Ref. Page
The brightness is not adjusted properly.	Select  in the mode menu and adjust the brightness.	P.180
The monitor is exposed to direct sunlight.	Position the monitor in the down position or block the sunlight with your hand.	—

Pictures you have taken do not appear on the monitor.

Possible cause	Corrective action	Ref. Page
The power is off.	Set the mode dial to  , then turn the power on.	P.53
The camera is in the shooting mode.	Press  twice quickly, or set the mode dial to  .	P.53, 54
There are no pictures on the card.	NO PICTURE appears on the monitor. Record pictures.	—
There is a problem with the card.	Refer to "Error codes".	P.205
The camera is connected to a TV.	The monitor does not function when the AV cable is connected to the camera.	P.151

The date recorded with the image data is wrong.

Possible cause	Corrective action	Ref. Page
The date/time is not set.	Set the date/time. The clock adjustment is not factory-preset.	P.36
The batteries are exhausted.	When the batteries run out, the date/time setting is canceled or becomes inaccurate. Replace the batteries with new ones and set the date/time again.	P.21, 36
The camera has been left with the batteries removed.	If the camera is left for several hours with the batteries removed, the date/time setting is canceled. Set the date/time again.	P.21, 36

Erasing, protecting or rotating pictures, setting print reservation data, and formatting cards cannot be performed.

Possible cause	Corrective action	Ref. Page
A write-protect seal is attached to the SmartMedia card.	Remove the seal before using the SmartMedia card. Do not reuse the write-protect seal.	P.25

The settings are returned to the factory default settings when the camera is turned off.

Possible cause	Corrective action	Ref. Page
All Reset is set to ON.	Select the SETUP tab in the mode menu and set All Reset to OFF.	P.164

No picture is displayed on the TV when connected to the camera.

Possible cause	Corrective action	Ref. Page
The video output signal is incorrect.	Set the video output signal according to the region where used.	P.192
The camera is not in the playback mode.	Set the mode dial to  .	P.151
The TV video signal setting is incorrect.	Set the TV to the video input mode.	P.151

● The image quality is poor.

The picture is too bright.

Possible cause	Corrective action	Ref. Page
The flash was set to the fill-in flash mode.	Select a flash mode other than fill-in flash.	P.79
The subject was excessively illuminated.	Adjust the exposure compensation toward minus (-) or change the camera position.	P.131

The picture is too dark.		
Possible cause	Corrective action	Ref. Page
The flash was blocked by your finger.	Hold the camera correctly, keeping your fingers away from the flash.	P.39
The subject was out of the working range of the flash.	Shoot within the flash working range.	P.79
The flash was set to the flash off mode.	Select a flash mode other than flash off.	P.79
The subject was too small and was backlit.	Set the flash to fill-in mode, or use the spot metering mode.	P.79, 102
The sequential shooting mode was used.	Higher shutter speeds are used when the sequential shooting mode is selected, which may result in pictures that are darker than usual. Select <input type="checkbox"/> in the DRIVE menu.	P.112

The colors of pictures taken indoors look unnatural.		
Possible cause	Corrective action	Ref. Page
Indoor lighting can affect the picture's colors.	Set the white balance according to the lighting.	P.133
There is no white in the subject.	Include something white in the picture, or shoot using the fill-in flash mode.	P.79
The white balance setting is wrong.	Adjust the white balance according to the light source.	P.133















The picture has obscured edge(s).		
Possible cause	Corrective action	Ref. Page
The lens was partly blocked by your finger or the strap.	Hold the camera correctly, keeping your fingers and the strap away from the lens.	P.39
The subject was too close.	Check the actual picture area by using the monitor to take the picture.	P.42
The lens was dirty.	Clean the lens. Use a commercially available blower brush and then wipe with a Lens cleaner to remove dust. Mold may form on the lens surface if the lens is left dirty.	P.224

The picture is out of focus.		
Possible cause	Corrective action	Ref. Page
The camera moved when the shutter button was pressed.	Hold the camera correctly and press the shutter button gently.	P.39
The subject was too close.	Position the camera more than 0.2 m/0.7 ft from the subject and take the picture. To take pictures closer than 0.2 m/0.7 ft, use the super macro mode.	P.107, 108
The flash was set to the flash off mode in a lighting condition requiring use of the flash.	Camera movement occurs easily with slower shutter speeds. Use a tripod, or hold the camera firmly.	P.79

Halation produces unnatural colors in the picture.		
Possible cause	Corrective action	Ref. Page
This may be caused by excessively bright ultraviolet light on the subject, such as sunlight shining through the leaves of trees, window frames in bright light at night, reflection of metal in direct sunlight, etc.	<ul style="list-style-type: none"> • Use a UV filter. As this may upset the overall color balance, it should only be used in the conditions described on the left. • Process the picture using a graphics application that supports JPEG (Paint Shop Pro, Photoshop, etc.). For example, after picking up unnatural colors with a syringe tool, etc. you can select color areas, and try color conversion or saturation adjustment. For details, refer to the manual for the graphics application you are using. 	—





List of menus

● P / A / S / M /  /  /  /  /  /  mode

Top menu	Tab	Function	Setting	Ref. Page	
MODE MENU	CAMERA	DRIVE ^{*1}	 ,	P.112	
		ISO	AF  , BKT		
		MY MODE ^{*2}	AUTO, 64, 100, 200, 400	P.130	
		FLASH	MY MODE 1 - MY MODE 8	P.95	
		SLOW	IN+  ,  , SLAVE	P.86	
		NOISE REDUCTION ^{*3}	 SLOW1,  SLOW,  SLOW2	P.84	
		DIGITAL ZOOM	OFF, ON	P.142	
		FULLTIME AF	OFF, ON	P.51	
		AF MODE	OFF, ON	P.97	
		PANORAMA ^{*4}	iESP, SPOT	P.96	
		2 IN 1	OFF, ON	P.122	
		FUNCTION	OFF, BLACK&WHITE, SEPIA, WHITE BOARD, BLACK BOARD	P.121	
		 ^{*5}	OFF,  ON, ON	P.144	
		PICTURE			RAW, TIFF, SHQ, HQ, SQ1, SQ2
	WB			AUTO, PRESET1, PRESET2, CUSTOM, 	P.133
				-7 - +7	P.138
	CUSTOM WB			CUSTOM 1, CUSTOM 2, CUSTOM 3, CUSTOM 4	P.135
	SCENE MODES ^{*3}			NORMAL,  ,  , 	P.142
	SHARPNESS			-5 - +5	P.139
	CONTRAST			-5 - +5	P.140
			SATURATION	-5 - +5	P.141
CARD		CARD SETUP	YES, NO	P.175	

To the next page

• P / A / S / M /  /  /  /  /  /  mode (cont.)

Top menu	Tab	Function	Setting	Ref. Page
MODE MENU	SETUP	ALL RESET ^{*6}	OFF, ON	P.164
		 ^{*7}	日本語, ENGLISH, FRANÇAIS, DEUTSCH, ESPAÑOL, 中文(繁体), 한국어	P.34
		PW ON SETUP	OFF, 1, 2	P.186
		PW OFF SETUP	OFF, 1, 2	P.186
		REC VIEW	OFF, ON	P.181
			OFF, LOW, HIGH	P.182
		BEEP	OFF, 1, 2	P.183
		SHUTTER SOUND	OFF, 1, 2	P.184
		MY MODESETUP	PRESENT, RESET, CUSTOM	P.172
		FILE NAME	RESET, AUTO	P.189
		PIXEL MAPPING		P.190
				P.180
				P.36
		m/ft	m, ft	P.191
		VIDEO OUT	NTSC, PAL	P.192
		SHORTCUT	A, B, C	P.169
		CUSTOM BUTTON		P.166
		DUAL CONTROL PANEL	OFF, ON	P.178
		AF ILLUMINATOR	OFF, ON	P.99
		(DRIVE)		
			Functions registered in the shortcut menus.	P.125
(WB)				P.133

*1 Cannot be selected in  mode.

*2 Can be selected only in  mode.

*3 Cannot be selected in      modes.











*4 Cannot be selected in **A S M** modes.

*5 Cannot be selected in **M** modes.















*6 Cannot be selected in  mode.

*7 Selectable languages differ according to the region where the camera is sold.







 mode

Top menu	Tab	Function	Setting	Ref. Page
MODE MENU	CAMERA	ISO	AUTO, 64, 100, 200, 400	P.130
		DIGITAL ZOOM	OFF, ON	P.51
		FUNCTION	OFF, BLACK&WHITE, SEPIA	P.121
	PICTURE		-7 - +7	P.138
		SCENE MODES	NORMAL,  ,  , 	P.142
		SHARPNESS	-5 - +5	P.139
		CONTRAST	-5 - +5	P.140
		SATURATION	-5 - +5	P.141
		CARD SETUP	YES, NO	P.175
	SETUP	ALL RESET	OFF, ON	P.164
		 *7	日本語, ENGLISH, FRANÇAIS, DEUTSCH, ESPAÑOL, 中文(繁体), 한국어	P.34
		PW ON SETUP	OFF, 1, 2	P.186
		PW OFF SETUP	OFF, 1, 2	P.186
			OFF, LOW, HIGH	P.182
		BEEP	OFF, 1, 2	P.183
		FILE NAME	RESET, AUTO	P.189
		PIXEL MAPPING		P.190
				P.180
				P.36
		VIDEO OUT	NTSC, PAL	P.192
		DUAL CONTROL PANEL	OFF, ON	P.178
 (movies)			P.124	
		HQ, SQ	P.125	
WB	AUTO, PRESET1, PRESET2, CUSTOM, 	P.133		

●  mode (still pictures)





















Top menu	Tab	Function	Setting	Ref. Page
MODE MENU	PLAY		START	P.122
	EDIT	RAW DATA EDIT	 WB, SHARPNESS, CONTRAST, SATURATION, FUNCTION, 	P.156
			640 x 480, 320 x 240, CANCEL	P.154
			NEW FILE, CANCEL	P.155
		COPY	ALL, SELECT	P.162
	CARD	CARD SETUP	 ALL ERASE,  FORMAT	P.175
	SETUP	ALL RESET	OFF, ON	P.164
		 *7	日本語, ENGLISH, FRANÇAIS, DEUTSCH, ESPAÑOL, 中文(繁体), 한국어	P.34
		PW ON SETUP	OFF, 1, 2	P.186
		PW OFF SETUP	OFF, 1, 2	P.186
		SCREEN SETUP	PW ON, PW OFF	P.187
		VOLUME		P.185
			OFF, LOW, HIGH	P.182
		BEEP	OFF, 1, 2	P.183
				P.180
				P.36
	VIDEO OUT	NTSC, PAL	P.192	
	4, 9, 16	P.148		
INFO			P.150	
			P.177	
				P.144









●  mode (movies)

Top menu	Tab	Function	Setting	Ref. Page
MODE MENU	EDIT	COPY	ALL, SELECT	P.162
	CARD	CARD SETUP	 ALL ERASE,  FORMAT	P.175
		SETUP	ALL RESET	OFF, ON
		 *7	日本語, ENGLISH, FRANÇAIS, DEUTSCH, ESPAÑOL, 中文(繁体), 한국어	P.34
		PW ON SETUP	OFF, 1, 2	P.186
		PW OFF SETUP	OFF, 1, 2	P.186
		VOLUME		P.185
			OFF, LOW, HIGH	P.182
		BEEP	OFF, 1, 2	P.183
				P.180
				P.36
		VIDEO OUT	NTSC, PAL	P.192
			4, 9, 16	P.148
	MOVIE PLAY		MOVIE PLAYBACK	PLAYBACK, FRAME BY FRAME, EXIT
		INDEX	OK, RESET, CANCEL	P.158
		EDIT	OK, RESET, CANCEL	P.160
INFO				P.177



List of factory default settings

● Shooting mode

FNo	F1.8
SHUTTER	1/1000
Zoom	Wide-angle
LCD	Off ( : On)
xD•SM/CF	xD (the card inserted in the xD•SM slot)
	±0
FLASH	AUTO (S M :  SLOW1,  : )
	±0
METERING	ESP (M  : fixed on )
AF /  / MF	AF
AF target mark	Center
Histogram target mark	Center
 	OFF
AE lock	Off
DRIVE	
BKT	±1 EV, ×3
ISO	AUTO (A S M : 64)
MY MODE	MY MODE 1
 FLASH	IN+ 
SLAVE	1
 SLOW	 SLOW1
NOISE REDUCTION	OFF ( : fixed on ON)
DIGITAL ZOOM	OFF
FULLTIME AF	OFF ( : ON)
AF MODE	iESP ( : fixed on iESP)
	OFF
 (movie)	OFF
PANORAMA	OFF
2 IN 1	OFF











FUNCTION	OFF
	OFF
	HQ (2560 × 1920,  : 320 × 240)
TIFF	2560 × 1920
SHQ	2560 × 1920
HQ	2560 × 1920
SQ1	1600 × 1200 NORMAL
SQ2	640 × 480 NORMAL
WB	AUTO
	±0
CUSTOM WB	OFF
SCENE MODES	NORMAL
SHARPNESS	±0
CONTRAST	±0
SATURATION	±0
ALL RESET	ON
	ENGLISH
PW ON SETUP	1
PW OFF SETUP	1
REC VIEW	ON
	LOW
BEEP	1-LOW
SHUTTER SOUND	1-LOW
MY MODE SETUP	PRESENT
FILE NAME	RESET
	NORMAL
	Y-M-D 2002/01/01 00:00
m/ft	m
VIDEO OUT	NTSC
SHORTCUT	A: DRIVE, B:  , C: WB
CUSTOM BUTTON	DRIVE
DUAL CONTROL PANEL	OFF
AF ILLUMINATOR	ON











● Playback mode

	OFF
INFO	OFF
	OFF
	OFF
	0°
	OFF
	640 × 480
	OFF
COPY	ALL
ALL RESET	ON
	ENGLISH
PW ON SETUP	1
PW OFF SETUP	1
SCREEN SETUP	BLUE BACKGROUND
VOLUME	3
	LOW
BEEP	1-LOW
FILE NAME	RESET
	NORMAL
VIDEO OUT	NTSC
	9

List of items by shooting mode

Mode		P	A	S	M			
Function								
Zoom		✓						
Digital zoom		✓						
AF		✓						
Focus lock		✓						
AF MODE		✓						—
FULLTIME AF		✓						
AF target		✓						—
AF ILLUMINATOR		✓						—
Manual focus		✓						—
FLASH MODE	AUTO	✓		—		✓	—	
		✓		—		✓	—	
		✓		—		✓	—	
	SLOW1			✓			—	
	SLOW	✓		—		✓	—	
	SLOW2			✓			—	
				✓			—	
			✓			—		
SLOW			✓			—		
FLASH			✓			—		
			✓			—		
MULTI		✓		—		✓	—	
		✓		—		✓	—	
				✓			—	
				✓			—	
MF				✓			—	
				✓			—	
				✓ ¹			—	
				✓ ¹			—	
BKT		✓		—		✓ ¹	—	

Mode		P	A	S	M	 		
								
Function								
PANORAMA		✓		—		✓	—	
2 IN 1				✓			—	
FUNCTION	BLACK & WHITE			✓				
	SEPIA			✓				
	WHITE BOARD			✓			—	
	BLACK BOARD			✓			—	
				✓			—	
 (movie)				—			✓	
				✓				
ISO				✓				
		✓			—	✓		
WB				✓				
				✓				
CUSTOM WB				✓				
SHARPNESS				✓				
CONTRAST				✓				
SATURATION				✓				
SCENE MODES			✓			—	✓	
NOISE REDUCTION			✓			—		
		✓			—	✓	—	
Histogram target mark		✓			—	✓	—	
ALL RESET				✓ ²				
				✓				
PW ON SETUP				✓				
PW OFF SETUP				✓				
REC VIEW				✓			—	

Mode Function	P	A	S	M	 	  	
							
				✓			
BEEP				✓			
SHUTTER SOUND				✓			—
MY MODE SETUP				✓			—
FILE NAME				✓			
PIXEL MAPPING				✓			
				✓			
				✓			
m/ft				✓			
VIDEO OUT				✓			
SHORTCUT				✓			—
CUSTOM BUTTON				✓			—
DUAL CONTROL PANEL				✓			

✓: Available

—: Not available

*1 Cannot be selected in  mode.*2 Cannot be selected in  mode.

Camera maintenance

● After use

Turn off the power and fit the lens cap on the lens.

● Cleaning the camera

1 Turn off the camera. (☞ P.31)

2 Remove the batteries (☞ P.21). (If you are using an AC adapter, unplug the AC adapter from the camera first before removing the plug from the AC outlet.)

3 Exterior:

→ Wipe gently with a soft cloth. If the camera is very dirty, soak the cloth in mild soapy water and wring well. Wipe the camera with the damp cloth and then dry it with a dry cloth. If you have used the camera at the beach, use a cloth soaked in clean water and well wrung.

Monitor and viewfinder:

→ Wipe gently with a soft cloth.

Lens:

→ Blow dust off the lens with a commercially available blower, then wipe gently with a lens cleaning paper.

Card:

→ Wipe gently with a soft, dry cloth.



Note

- Do not use strong solvents such as benzene or alcohol, or chemically treated cloth.
- Cleaning should be done only after the batteries have been removed or the AC adapter has been disconnected.
- Mold may form on the lens surface if the lens is left dirty.

Specifications

Product type	: Digital camera (for shooting and displaying)
Recording system	
Still picture	: Digital recording, TIFF (non-compression), JPEG (in accordance with Design rule for Camera File system (DCF)), Exif 2.2 compatible, Digital Print Order Format (DPOF), RAW data
Still picture with sound	: Wave format
Movie	: QuickTime Motion JPEG support
Memory	: xD-Picture Card (16 – 128MB) SmartMedia (4MB, 8MB, 16MB, 32MB, 64MB, 128MB)* ¹ Compact Flash, Microdrive* ² ^{*1} 2MB and 5V SmartMedia cannot be used. ^{*2} 340MB Microdrive cannot be used.
Recording image resolution	: 3200 × 2400 pixels (ENLARGE SIZE SHQ, HQ) 2560 × 1920 pixels (RAW, TIFF, SHQ, HQ) 2560 × 1696 pixels (3:2 TIFF, SHQ, HQ) 2288 × 1712 pixels (TIFF, SQ1) 2048 × 1536 pixels (TIFF, SQ1) 1600 × 1200 pixels (TIFF, SQ1) 1280 × 960 pixels (TIFF, SQ2) 1024 × 768 pixels (TIFF, SQ2) 640 × 480 pixels (TIFF, SQ2)
No. of storable pictures	
When a 32MB card used (without sound)	: Approx. 4 frames (RAW: 2560 × 1920) Approx. 2 frames (TIFF: 2560 × 1920) Approx. 8 frames (SHQ: 2560 × 1920) Approx. 26 frames (HQ: 2560 × 1920) Approx. 64 frames (SQ1: 1600 × 1200 NORMAL) Approx. 331 frames (SQ2: 640 × 480 NORMAL)
No. of effective pixels	: 5,000,000 pixels
Image pickup device	: 1/1.8" CCD solid-state image pickup, 5,260,000 pixels (gross)
Lens	: Olympus lens 7.1 mm to 21.3 mm, f1.8 to 2.6, 8 elements in 6 groups (equivalent to 35 mm to 105 mm lens on 35 mm camera)

Photometric system	: Digital ESP metering, spot metering
Aperture	: F1.8 to F8.0
Shutter speed	: 16 to 1/2000 sec.
Shooting range	: 0.8 m (2.6 ft.) to ∞ (normal) 0.2 m to 0.8 m (0.7 ft. to 2.6 ft.) (macro mode)
Viewfinder	: Optical real image viewfinder (with AF target mark)
Monitor	: 1.8" TFT color LCD display, 114,000 pixels
Autofocus	: TTL system autofocus Contrast detection method/focal adjustment range
Outer connector	: DC-IN jack, USB connector, A/V OUT jack
Automatic calendar system	: Up to 2099
Operating environment	
Temperature	: 0°C to 40°C (32°F to 104°F) (operation) -20°C to 60°C (-4°F to 140°F) (storage)
Humidity	: 30% to 90% (operation)/10% to 90% (storage)
Power supply	: 2 CR-V3 lithium battery packs, or 4 AA (R6) alkaline batteries, lithium batteries, NiMH batteries or NiCd batteries. AC adapter (optional) Manganese (zinc-carbon) batteries cannot be used.
Dimensions	: 113.5 mm (W) × 69.5 mm (H) × 79.5 mm (D) (4.5" × 2.7" × 3.1") (excluding protrusions)
Weight	: 375 g (0.8 lb.) (without batteries or card)

SPECIFICATIONS ARE SUBJECT TO CHANGE WITHOUT ANY NOTICE OR OBLIGATION ON THE PART OF THE MANUFACTURER.

Glossary of terms

A (Aperture Priority) Mode

You set the aperture yourself and the camera automatically varies the shutter speed so that the picture is taken with the best exposure.

AE (Automatic Exposure)

The camera's built-in exposure meter automatically sets the exposure. The 3 AE modes available on this camera are P mode, in which the camera selects both the aperture and shutter speed, A mode, in which the user selects the aperture and the camera sets the shutter speed, and S mode, in which the user selects the shutter speed and the camera sets the aperture.

In M mode, the user selects both the aperture and the shutter speed.

Aperture

The adjustable lens opening which controls the amount of light that enters the camera. The larger the aperture, the shorter the depth of field and the fuzzier the background. The smaller the aperture, the greater the depth of field and the sharper the background. Aperture is measured in f/stops. Larger aperture values indicate smaller apertures, and smaller aperture values indicate larger apertures.

Backlight

A light source to illuminate the monitor from behind the screen.

CCD (Charge-Coupled Device)

This converts light passing through the lens into electrical signals. On this camera, light is picked up and converted into RGB signals to build a single image.

Contrast Detection Method

This is used to measure the distance to the subject. The camera determines if the image is focused by the level of contrast in the subject.

Conventional Photograph

This refers to recording images using silver halide (the method for recording images in conventional, non-digital photography). This system is in contrast to still video and digital photography.

DCF (Design rule for Camera File system)

A standard for image files by the Japan Electronics and Information Technology Industries Association (JEITA).

Digital ESP (Electro-Selective Pattern) Light Metering

This determines the exposure by metering and calculating the light levels in the center and other areas of the image separately.

DPOF (Digital Print Order Format)

This is for saving desired print settings on digital cameras. By entering which images to print and the number of copies of each, the user can easily have the desired images printed by a printer or print lab that supports the DPOF format.

Eclipsing (Vignetting)

This refers to when an object obscures part of the field of view so that the whole subject is not photographed. Vignetting also refers to when the image seen through the viewfinder does not exactly match the image shot through the objective lens, so the photographed image includes objects not seen through the viewfinder. In addition, vignetting can occur when an incorrect lens hood is used, causing shadowing to appear in the corners of the image.

Effective Pixel Resolution

The number of pixels used in the CCD to create the image.

EV (Exposure Value)

A system for measuring exposure. EV0 is when the aperture is at F1 and the shutter speed is 1 second. The EV then increases by 1 each time the aperture increases by one F stop or the shutter speed increases by one increment. EV can also be used to indicate brightness and ISO settings.

Exposure

The amount of light used to capture an image. The exposure is determined by the time the shutter is open (shutter speed) and the amount of light that passes through the lens (aperture).

Flash Bracket

A mount used to attach an external flash to the camera. Shadows on the subject can be changed by detaching the flash. The flash is used in combination with the flash cable.

Gross Pixel Resolution

The total number of pixels in a CCD. Not all pixels are used to create the image.

ISO

A method for indicating film speed by the International Organization for Standardization (ISO) (e.g. "ISO100"). Higher ISO values indicate greater sensitivity to light, so images can be exposed even in low-light conditions.

JPEG (Joint Photographic Experts Group)

A compression format for color still images. Photographs (images) shot using this camera are recorded onto the card in JPEG format when the Record mode is set to SHQ, HQ, SQ1 or SQ2. By downloading these images to a personal computer, users can edit them using graphics application software or view the images using an Internet web browser.

M (Manual) Mode

The user sets both the aperture and shutter speed.

NTSC (National Television Systems Committee) / PAL (Phase Alternating Line)

Television formats. NTSC is mainly used in Japan, North America and Korea. PAL is mainly used in Europe and China.

P (Program) Mode

Also called Program AE mode. The camera automatically sets the best shutter speed and aperture for the shot.

Pixels

A pixel is the smallest unit (dot) used to make up an image. Clear large-sized printed images require millions of pixels.

Ring Flash

A flash unit that uses a circular xenon fluorescent tube as its light source. It is used for taking close-ups.

S (Shutter Priority) Mode

Also called Shutter Priority AE mode. The user selects the shutter speed and the camera automatically varies the aperture so that the picture is taken with the best exposure.

Slave Flash

A wireless flash that is not connected to the camera by a synchronization cord. It flashes in phase with the flash on the camera, and can be used for lighting techniques such as changing the way shadows are cast on a subject.

Sleep Mode

A mode designed to save battery life. The camera automatically enters the sleep mode if you do not operate it for a certain time. To get out of the sleep mode, use any button on the camera (shutter button, arrow pad, etc.).

Synchro Terminals

Terminals on an external flash unit for connecting it to the camera.

TIFF (Tagged Image File Format)

An uncompressed format used for saving highly detailed black and white or color image data. TIFF image files can be handled by software programs for scanners and graphics applications.

TFT (Thin-Film Transistor) Color Monitor

A color monitor constructed using thin-film technology.

TTL (Through-The-Lens) System



To help adjust exposure, a light receptor built into the camera directly measures the light passing through the lens.

TTL-AUTO

For use with an external flash. Light emitted by the flash is measured by the light receptor in the camera as it passes through the lens. A signal is then sent to adjust the external flash intensity.

3:2 129



A

A/V OUT jack 10, 151
 AC adapter 23
 AE lock **(AEL)** 105
 AE memory **(MEMO)** 106
 AEL button 11, 105
 AF Illuminator 10, 99
 AF mode 96
 AF sequential shooting
 AF  112
 AF target mark 11, 40
 AF/Macro/MF button
 12, 100, 107, 108
 Alkaline battery 23
 All reset 164
 All-frame erase  163
 All-frame reservation 197
 Aperture priority shooting
 A 59, 91
 Aperture value 91
 Arrow pad 11, 53, 69
 Auto bracketing **BKT** 113
 Auto flash 81
 Auto focus 46
 Auto white balance 133
 AV cable 151

B

Batteries 21
 Battery check 18
 Battery compartment cover .. 11, 21
 Battery compartment lock ... 11, 21
 Beep sound **(■))** 182
 BKT 113
 Black and white picture 121
 Black board 121
 Button operation beep 183



C



















Camera movement warning 80
 Card 25
 Card access lamp 11, 40
 Card button 11, 29
 Card check 33
 Card cover 11, 26
 Card setup 175
 Close-up playback **Q** 147
 Cloudy day  134
 Compact Flash (CF) 25, 29
 Connector cover 10, 151
 Contrast 140
 Control panel 10, 13
 Copy 162
 Custom button  12, 166
 CUSTOM WB setting 135
 Custom white balance 135



















D









Date/time setting  36
 DC-IN jack 10, 23
 Digital zoom 51
 Diopter adjustment dial 12, 38
 Direct buttons 63
 DPOF 195
 Drive 112
 Dual control panel 178

E

Editing movies 158
 Enlarge size 129
 Erasing pictures 58
 Error codes 205
 ESP metering 102
 Evening sunlight  134
 Exposure compensation  131
 Exposure compensation button
 12, 93, 131
 Exposure differential 93

- F**
- File name 189
 - File number 189
 - Fill-in flash  81
 - Flash 10, 79
 - Flash charge 15, 80
 - Flash intensity control  85
 - Flash intensity control button 66
 - Flash mode 79
 - Flash mode button 12, 79
 - Flash off  82
 - Flash stand-by 15, 80
 - Fluorescent lamp  134
 - Focus lock 46
 - Formatting 175
 - Front curtain  **SLOW1** 82
 - Front curtain with red-eye reduction 83
 - Fulltime AF 97
 - Fully pressed 41
 - FUNCTION 121
- G**
- Green lamp 11, 40, 42
- H**
- Halfway pressed 40
 - High quality 126
 - High speed sequential shooting **HI**  112
 - Histogram display  144
 - Histogram target mark 146
 - Hot shoe 10, 86
 - Hot shoe cover 86
 - HQ 125
- I**
- iESP 96
 - Index (Creating an index) 158
 - Index display  148
- Information display 177
- ISO sensitivity 130
- J**
- Jog dial 11, 63
- L**
- Landscape shooting  62
 - Landscape+Portrait shooting  62
 - Language setting  34
 - Lens 10
 - Lens cap 20
 - Lens cap string 20
 - Lithium battery pack 23
- M**
- Macro mode shooting  107
 - Manual focus 100
 - Manual shooting **M** 60, 93
 - Measurement units **m/ft** 191
 - Memory gauge 18
 - Metering  **MULTI**  102
 - Metering button 12, 102
 - Microdrive 25, 29
 - Microphone 10, 122, 153
 - Mode 59
 - Mode dial 12, 59
 - Mode menu 69
 - Monitor brightness adjustment  180
 - Movie   48
 - Movie play 55, 158
 - Multi-metering 103
 - My mode setup 172
 - My mode shooting  61, 95
- N**
- Night scene shooting  61
 - NiMH battery 23

- Noise reduction 142
 No. of storable still pictures 126
 Normal quality 126
 NTSC..... 192, 229
- O**
- OK/Menu button  11, 69
 One-touch white balance
 136
 Optical zoom 50
 Orange lamp 11, 40
- P**
- PAL 192, 229
 Panorama 116
 Picture rotation 152
 Pixel mapping 190
 Playback mode 17, 32
 Playback volume 185
 Playing back movies 55
 Playing back pictures on a TV . . 151
 Portrait shooting  62
 Power switch 11, 31
 Preset white balance 134
 Print button  12, 197
 Print reservation 197
 Program shooting **P** 59
 Protect button  12, 57
 Protecting 57
 PW OFF setup..... 186
 PW ON setup 186
- Q**
- Quick View 54
- R**
- RAW 125, 129
 RAW editing 156
 Rear curtain  **SLOW2** 83
 Rec View 181
- Rechargeable batteries.....23
 Recording movies 48
 Recording sound 153
 Recording sound with still
 pictures 122
 Red-eye reduction flash 81
 Remote control 110
 Remote control Receiver . . .10, 110
 Resizing 154
 Resolution.....126
 Rotation button 12, 152
- S**
- Saturation141
 Scene modes142
 Screen setup.....187
 Seconds remaining.....48
 Self-timer 109
 Self-timer/Remote control button
12, 109, 110
 Self-timer/Remote control lamp
10, 109, 110
 Sepia.....121
 Sequential shooting 112
 Shade 134
 Sharpness.....139
 Shooting mode15, 31
 Shooting mode menu59
 Shortcut menus.....69, 72
 SHQ125
 Shutter button.....12, 40
 Shutter priority shooting **S** . . .60, 92
 Shutter sound184
 Shutter speed92
 Single-frame erase 58
 Single-frame playback53
 Single-frame reservation.....199
 Single-frame shooting.....40, 112
 Slave flash229
 Slave flash mode90

- Slideshow  150
- Slow synchronization  **SLOW** 82, 84
- SmartMedia (SM) 25, 29
- Speaker 11, 185
- Sports shooting  62
- Spot metering 102
- SQ 125
- Strap 20
- Strap eyelet 10, 20
- Sunny day  134
- Super macro mode shooting
 108
- Super macro MF mode shooting
 108
- T**
- TIFF 125
- Top menu 69
- Trimming  155
- Tripod socket 11
- Tungsten light  134
- Two-in-one pictures **2 IN 1** ... 119
- U**
- USB connector 10
- V**
- Video output 192
- Viewfinder 11, 38
- Volume 185
- W**
- White balance **WB** 133
- White balance adjustment
 138
- White board 121
- Write-protect seal 25
- X**
- xD-Picture Card 25, 29
- Z**
- Zoom lever 12, 50, 147, 148

OLYMPUS

<http://www.olympus.com/>

OLYMPUS OPTICAL CO., LTD.

San-Ei Building, 22-2, Nishi Shinjuku 1-chome, Shinjuku-ku, Tokyo, Japan
Customer support (Japanese language only): Tel. 0426-42-7499 Tokyo

OLYMPUS AMERICA INC.

Two Corporate Center Drive, Melville, NY 11747-3157, U.S.A. Tel. 631-844-5000

Technical Support (USA)

24/7 online automated help: <http://support.olympusamerica.com/>

Phone customer support: Tel. 1-888-553-4448 (Toll-free)

Our phone customer support is available from 8 am to 10 pm
(Monday to Friday) ET

E-Mail: distec@olympus.com

Olympus software updates can be obtained at: <http://olympus.com/digital/>

Adobe [Photoshop] Support

Adobe software updates and technical information can be obtained at:
<http://www.adobe.com/support/>

OLYMPUS OPTICAL CO. (EUROPA) GMBH.

Premises/Goods delivery: Wendenstrasse 14-18, 20097 Hamburg, Germany
Tel. 040-237730

Letters: Postfach 10 49 08, 20034 Hamburg, Germany

Hotline Numbers for customers in Europe:

Tel. 01805-67 10 83

for Germany

Tel. 00800-67 10 83 00

for Austria, Belgium, Denmark, France,
Netherlands, Norway, Sweden, Switzerland,
United Kingdom

Tel. +49 180 5-67 10 83

for Finland, Italy, Luxembourg, Portugal,
Spain, Czech Republic

Tel. +49 40-237 73 899

for Greece, Croatia, Hungary, and the rest of Europe

Our Hotline is available from 9 am to 6 pm (Monday to Friday)

E-Mail: di.support@olympus-europa.com

OLYMPUS

CAMEDIA

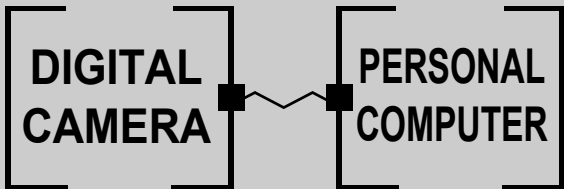

DIGITAL CAMERA — PC CONNECTION
OPERATION MANUAL

How to use your PC to get the most from images taken with your digital camera.

- Thank you for purchasing an Olympus digital camera.
- This manual provides instructions on how to install the USB driver. To ensure correct installation, refer only to these installation procedures.

Introduction

This manual explains in detail how to connect your Olympus digital camera to a computer. Read it carefully and keep it in a safe place for future reference.

About this manual

- The information contained in this manual may be subject to change without notice. For the latest information on the product, please consult your local Olympus representative.
- The information contained in this manual has been compiled by taking all possible measures to ensure its accuracy. However, if you find any errors or incomplete information, please contact your local Olympus representative.
- It is prohibited by copyright laws to duplicate in part or in whole the information contained in this manual, except for personal use. Reproduction without permission of the copyright owner is prohibited.
- The PC screens shown in this manual may differ slightly from the actual displays on some PC models.

Trademarks

- Microsoft and Windows are registered trademarks of Microsoft Corporation.
- Macintosh is a trademark of Apple Computer Inc.
- All other company and product names are registered trademarks and/or trademarks of their respective owners.

INDEX

Flowchart 4

Identifying the OS 6

Windows (98/Me/2000/XP) 8

Macintosh (OS 9/X). 23

**Downloading image files using other OS
(For other OS users). 31**

Windows

Macintosh

Flowchart

By connecting the camera to a computer with the provided USB cable, images on a card can be transferred to the computer. Some OS's (operating systems) may need a special setup before connecting to the camera for the first time. Follow the chart below.

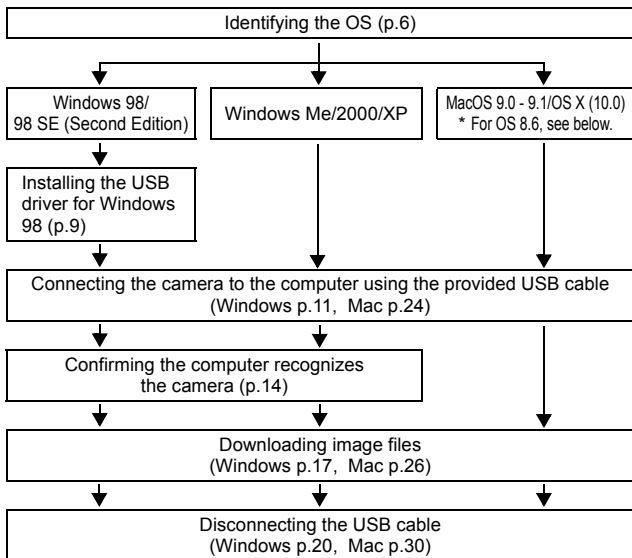

* Even if your computer has a USB connector, data transfer may not function correctly if you are using one of the operating systems listed below or if you have an add-on USB connector (extension card, etc.).

- Windows 95/NT 4.0
- Windows 98/98 SE upgrade from Windows 95
- Mac OS 8.6 or lower (except Mac OS 8.6 equipped with USB MASS Storage Support 1.3.5 installed at the factory)
- Data transfer is not guaranteed on a home-built PC system or PCs with no factory installed OS.



- When connecting the camera to the computer, make sure that there is sufficient remaining battery power. When connected (transmitting) to the computer, the camera does not enter the sleep mode nor will the camera's power turn off automatically. Depending on the camera model, when the battery power runs out or the internal temperature rises, the camera may stop operating automatically. This could cause the computer to malfunction, and any image data (file) being transmitted may be lost. Be careful when downloading files for a long period of time. Use the AC adapter (optional) when downloading files.
- If you connect or disconnect the AC adapter when the camera is connected to the computer and is running on battery power, it may result in the loss of image data on the card or cause a malfunction in the computer. Before connecting or disconnecting the AC adapter, disconnect the camera from the computer and make sure that the camera is turned off.
- To avoid computer malfunctions, do not turn off the camera when the camera is connected to a computer.
- If the camera is connected to the computer via a USB hub, operation may not be stable if there are any compatibility problems between the computer and the hub. In such cases, do not use the hub and connect the camera directly to the computer.



- You can view images using: graphics applications that support the JPEG file format (Paint Shop Pro, Photoshop, etc.); Internet browsers (Netscape Communicator, Microsoft Internet Explorer, etc.); CAMEDIA Master software; or other software. For details on using commercial graphics applications, refer to their instruction manuals.
- QuickTime is needed for playing back movies. QuickTime is included on the provided software CD.
- If you want to process images, make sure to download them to your computer first. Depending on the software, image files may be destroyed if the images are processed (rotated, etc.) while they are on the card.

Identifying the OS

Identify the OS on your computer before connecting the camera. How to identify the OS depends on the computer.

● Windows

- 1** Double-click the “My Computer” icon on your desktop.

When the “My computer” icon is not on your desktop, click “Control Panel” from the “Start” menu.

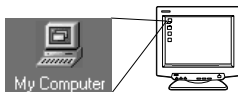

- 2** Double-click the “Control Panel” icon.



- 3** Double-click the “System” icon.



The way the file icons inside the folder appear may vary depending on your version of Windows. If you don't see the icon you are looking for, click on “view all Control Panel options” on the left of the window.

4 A System Properties window will appear. Note and record the “System:” information.

Confirm that your system is Windows 98, 98 SE, Me, 2000 Professional or Windows XP, then press “OK” to close the window.

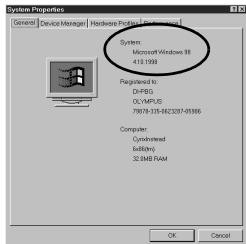

If your OS is Windows 98/98 SE, proceed to “Installing the USB driver for Windows 98” (👉 p.9).

Users running Windows Me/2000/XP 👉 p.11

Users running other OS 👉 p.31

● Mac OS (Macintosh)

Select “About This Computer” from the Apple menu on the menu bar.

A window appears with the name of the computer’s OS.

Confirm that the OS is OS 9.0-9.1 or OS X.

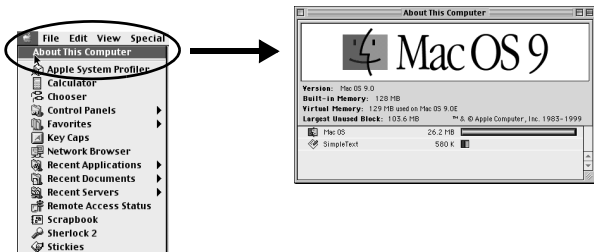

Users running Mac OS 9/X 👉 p.23

Users running other OS 👉 p.31

Windows

Using Windows 98/Me/2000/XP

Make sure that:

- Your computer is turned on and Windows is running.
- If you are running any applications, quit them all.
- You are recommended to power the camera using the optional AC adapter. If the battery power runs out while the computer is accessing the card in the camera, the camera will turn off in the middle of the operation and this could destroy image files (data). If you are using batteries, make sure that there is sufficient remaining battery power.

Installing the USB driver for Windows 98 (When using Windows 98/98 SE)	9
Connecting the camera to the computer	11
Confirming the computer recognizes the camera	14
Confirming the USB driver is installed	15
Downloading images to your computer.....	17
Disconnecting the camera from your computer	20

Installing the USB driver for Windows 98 (When using Windows 98/98 SE)

If your OS is Windows 98/98 SE, you must install the USB driver. Follow the instructions below to install the USB driver in your computer. Once it is fully installed, you do not need to repeat the procedure again.

If your OS is Windows Me/2000/XP, skip the procedure below as the USB driver will be automatically installed. Proceed to “Connecting the camera to the computer” (👉 p.11).

- 1** Insert the provided software CD into your CD-ROM drive.

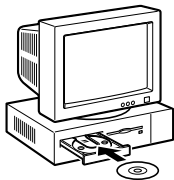

- 2** The Olympus Windows Installer should automatically launch. Click “USB driver for Windows 98”.

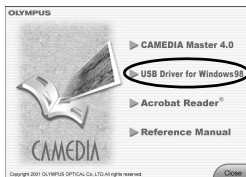

If the installer is not automatically launched, select “Run..” on the “Start” menu and then execute “(drive letter):/ Information.exe”.



The drive letter of the CD-ROM varies depending on the computer.
To identify the drive letter, double-click “My Computer” on the desktop.

- 3** Click “Continue”. The installation of the USB driver will start.



- 4** Click “OK” to restart your computer and the installation is complete.

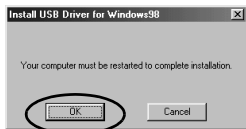

- 5** When the computer has restarted, installation is complete. If the Olympus Windows Installer screen appears, click “Close” and remove the CD-ROM from the CD-ROM drive.

Connecting the camera to the computer

Users running Windows 98/98SE need to install the USB drive before connecting the camera to your computer for the first time. (☞ p.9)

- 1** Insert the marked end of the provided USB cable into the USB port on your computer as shown below.

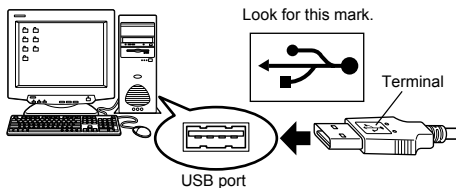

Note

The location of the USB port varies depending on the computer. For details, refer to your computer's manual.

- 2** After making sure that the camera is turned off, connect the end of the USB cable to the USB connector on the camera.

The location of the USB connector or multi connector varies depending on the camera model. Refer to the camera manual for details.

Camera with a USB connector

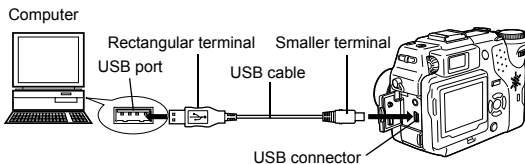

Camera with a multi connector

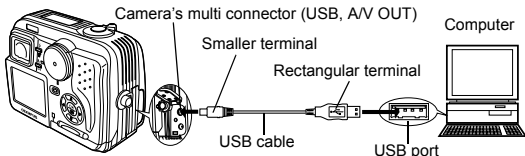

3 Turn the camera on.

- **Camera with a lens barrier**

The power turns on automatically, with the exception of some models which require you to press the  (monitor) button.

When the camera is turned on, the lamp on the right of the viewfinder lights up.

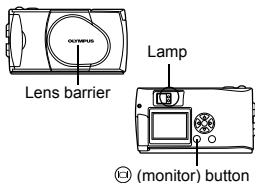

- **Camera with a  mode**

Set the mode dial to . (If the camera has a power switch as well as a mode dial, turn the power switch to ON.)

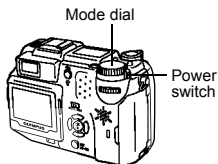
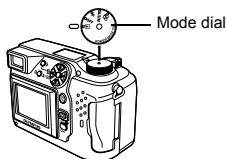

- **Camera with a  mode (Camera setup/connection mode)**

Set the mode dial to  to turn the camera on.

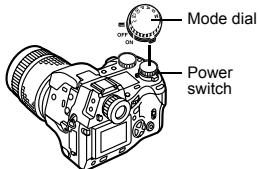

4 The computer recognizes the camera as a new device.

When you connect the camera to the computer for the first time, the computer automatically recognizes the camera. Click "OK" when the message saying that the installation is completed appears. The computer recognizes the camera as a "Removable Disk".

● Windows XP

You can download image files from the camera easily. Select "Copy pictures to folder on my computer using Microsoft Scanner and Camera Wizard", then follow the on-screen instructions. You may also select "take no action" to bypass the Microsoft Scanner and Camera Wizard. You may then use a more advanced image viewing/editing program such as Olympus CAMEDIA Master software. For detailed instructions on downloading, refer to the CAMEDIA Master software user's guide.



When the camera is connected to the computer, none of the camera buttons are functional.

Confirming the computer recognizes the camera

1 Double-click the “My Computer” icon on the desktop.

For users running Windows XP, click “My Computer” from the “Start” menu.

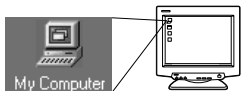

2 Make sure the “Removable Disk” icon appears in the window.

There may already be other “Removable Disk” icons for other devices, such as a removable media drive or USB Reader/Writer. In this case, the digital camera is recognized as another “Removable Disk”.

If you cannot find the icon, the camera and computer are not connected properly. Turn the camera off, disconnect the camera from the computer and connect again, or

proceed to “Confirming the USB driver is installed” (p.15) to make sure that the USB driver is fully installed.

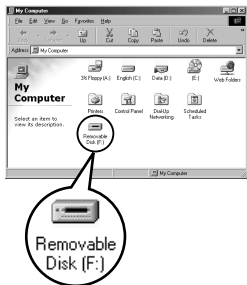

Confirming the USB driver is installed

If the computer does not recognize the camera as a Removable Disk, follow the procedure below to check whether the USB driver has been fully installed.

- 1** Open “My Computer” and double-click the “Control Panel” icon.
For users running Windows XP, open “Control Panel” from the “Start” menu.



- 2** Double-click the “System” icon.

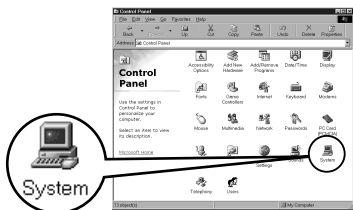

- 3** The System window will appear. Click the “Device Manager” tab.

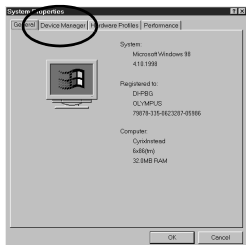

4 Confirm that “OLYMPUS Digital Camera” is in the “Universal Serial Bus Controller” category.

If you cannot find the “OLYMPUS Digital Camera”, turn the camera off, disconnect the camera from the computer and start again.

Users running Windows 98/98 SE start again from “Confirming the USB driver is installed”, and Users running Window Me/2000/XP start from “Connecting the camera to the computer”.

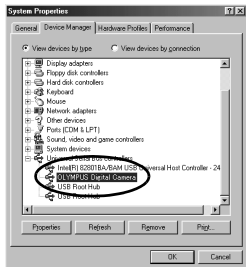

Note

If the USB driver was successfully installed, you can find the following in the “Device Manager”.

- the name of the camera you have connected listed under “Disk drives”
- “OLYMPUS Digital Camera” listed as one of the items in the “Universal Serial Bus Controller” category

Downloading images to your computer

1 Double-click the “My Computer” icon on the desktop.

For users running Windows XP, click “Control Panel” from the “Start” menu.

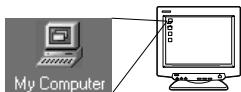

2 Double-click the “Removable Disk” icon.

A new “Removable Disk” icon appears when the camera is connected to the computer, as the digital camera is recognized as a “Removable Disk”.

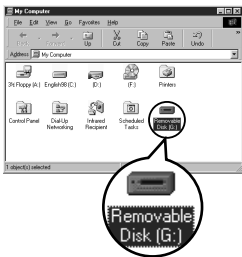

Note

If an error message appears when you double-click the icon, there may be a problem with one of the following:

- ① the camera's power source (the AC adapter is not properly connected or the battery power is low)
Make sure that the AC adapter is correctly connected or that the batteries are not running low.
- ② the card (there is no card in the camera or there is a problem with the card)
Check that you can play back pictures stored on the card on the monitor of your digital camera.

3 Double-click the “Dcim” folder.

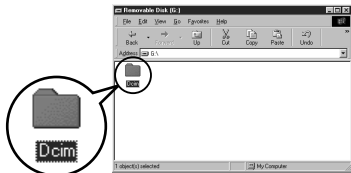

4 Double-click the “100olymp” folder.

Image files (JPEG files) with file names such as “P1010001.jpg” are displayed.

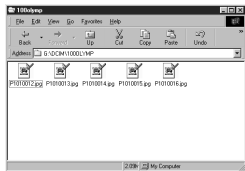

- The camera automatically assigns folder names and file names according to the following rules.

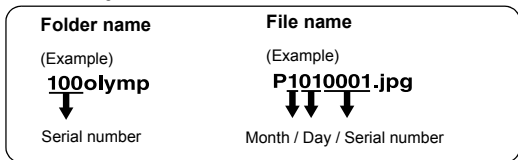

- Serial numbers of image files run from 0001 to 9999.
- Serial numbers of folders run from 100 to 999.
- When file number 9999 is reached, a new folder is created and assigned the next number.
- Months January through September are expressed by the numbers 1 through 9, October by the letter A, November by B and December by C.

5 Double-click the “My Documents” icon on the desktop.

If you cannot find the icon on the desktop, select “Explorer” on the Start menu and double-click the “My Documents” icon.

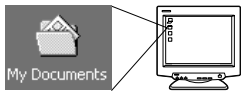

The “My Documents” window is displayed.

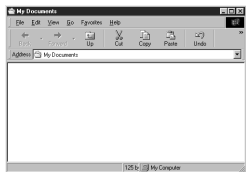

- 6** Drag & drop the image you want to save in the computer (in this case, P1010012.jpg) to the “My Documents” window.

The image is saved in the computer (in My Documents folder).

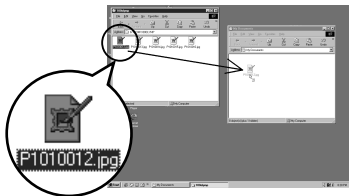

- To select all files, choose Edit > Select all.



Note

When the image file has been downloaded to the computer, you can view images by double-clicking the image files downloaded to your computer. The files will be opened in the default image viewer of the operating system. If you want to view the image a different size or process it, you will need to open the image with software that supports JPEG or TIFF images files, such as Paint Shop Pro, Photoshop or CAMEDIA Master software.



Caution

The lamp on the right of the viewfinder or the card access lamp blinks while the image is being copied. Never open the card cover on the camera, load or remove the batteries, or connect or disconnect the AC adapter while the lamp is blinking as the image files may be destroyed.

Disconnecting the camera from your computer

If your OS is Windows Me/2000, proceed to “Windows Me/2000/XP” (p.21).

● Windows 98

- 1** Make sure that the lamp on the right of the viewfinder or the card access lamp is not blinking.

Some camera models have either a lamp on the right of the viewfinder or a card access lamp, and the location varies depending on the model. Refer to your camera's reference manual.

Lamp

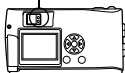

Card access lamp

- 2** Double-click the “My Computer” icon and right-click the “Removable Disk” to display the menu.



Removable
Disk (F:)

- 3** Click “Eject” on the menu.



- 4** Make sure that the lamp on the right of the viewfinder or the card access lamp is not blinking.

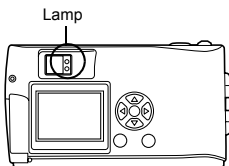

- 5** Remove the USB cable from the camera.

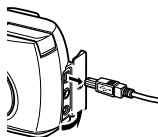

- 6** Remove the USB cable from your computer.

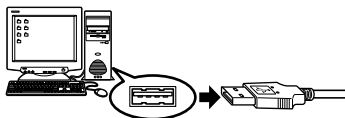

Windows

● Windows Me/2000/XP

- 1** Make sure that the lamp on the right of the viewfinder or the card access lamp is not blinking.

Some camera models have either a lamp on the right of the viewfinder or a card access lamp, and the location varies depending on the model. Refer to your camera's reference manual.

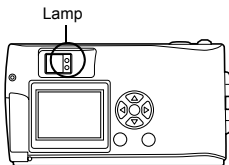

- 2** Click the  “Unplug or Eject Hardware” icon on the task bar.

The message saying that the drive has been stopped appears.

- 3** Click on the message.

The “Unplug or Eject Hardware” window appears.

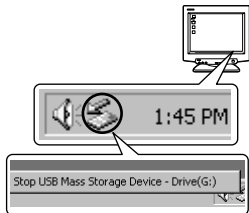

- 4** When a message appears, click “OK”.



- 5** Remove the USB cable from the camera.

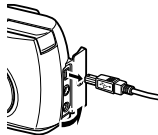

- 6** Remove the USB cable from your computer.

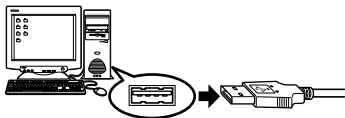

Caution

If the window returns the following message when you click “Unplug or Eject Hardware”, first make sure that no image data is being downloaded from the camera, and then remove the USB cable.



Macintosh

Using Mac OS (9/X)

Make sure that:

- Your computer is turned on and Mac OS is running.
- If you are running any applications, quit them all.
- You are recommended to power the camera using the optional AC adapter. If the battery power runs out while the computer is accessing the card in the camera, the camera will turn off in the middle of the operation and this could destroy image files (data). If you are using batteries, make sure that there is sufficient remaining battery power.

If you are running Mac OS X, the connection to the computer and downloading the image data are verified. Restrictions such as the following may occur due to the OS.

- The image file properties are not displayed correctly.
- Images in the camera cannot be opened without first downloading them. etc.

For more details, visit the Olympus web site.

Connecting the camera to the computer	24
Downloading images to your computer.....	26
Disconnecting the camera from your computer	30

Connecting the camera to the computer

- 1** Insert the marked end of the USB cable into the USB port on your computer as shown below.

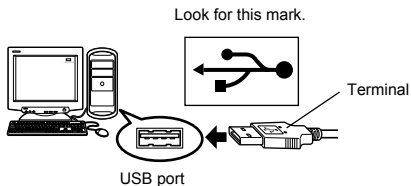

The location of the USB port varies depending on the computer. For details, refer to your computer's manual.

- 2** After making sure that the camera is turned off, connect the end of the USB cable to the USB connector on the camera.
- The location of the USB connector or multi connector varies depending on the camera model. Refer to the camera manual for details.

Camera with a USB connector

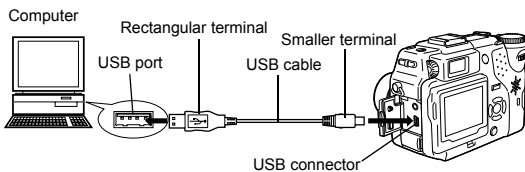

Camera with a multi connector

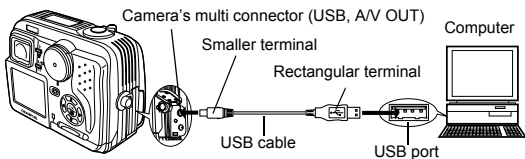

3 Turn the camera on.

● Camera with a lens barrier

The power turns on automatically, with the exception of some models which require you to press the  (monitor) button.

When the camera is turned on, the green lamp on the right of the viewfinder lights up.

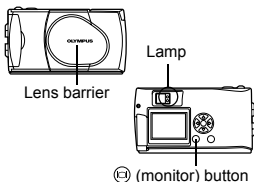

● Camera with a mode

Set the mode dial to . (If the camera has a power switch as well as a mode dial, turn the power switch to ON.)

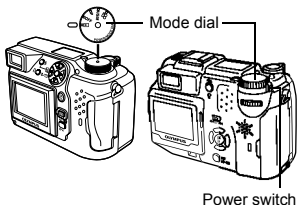

● Camera with a mode (Camera setup/connection mode)

Set the mode dial to  to turn the camera on.

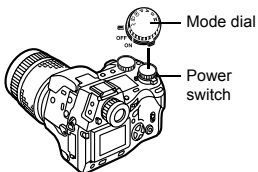

4 The computer recognizes the camera as a new device.

The computer recognizes the camera automatically and an "Untitled" icon appears on the desktop.

If you cannot find this icon, turn off the camera and connect again.

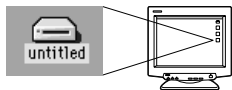

● Mac OS X

When the computer has recognized the camera, the Apple Image Capture software automatically launches.  p.29



When the camera is connected to the computer, none of the camera buttons are functional.

Downloading images to your computer

● Mac OS 9

You can download images from the camera and save them in your computer (in this case, in the Hard Disk).

- 1 Double-click the “Untitled” icon displayed on the desktop when the camera is connected to the computer.

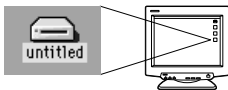

If you cannot find this icon, or if an error message appears when you double-click the icon, there may be a problem with one of the following:

- ① the camera's power source (the AC adapter is not properly connected or the battery power is low)
- ② the card (there is no card in the camera or there is a problem with the card)
Check that you can play back pictures on the monitor of your camera.
- ③ the USB cable (the camera is not properly connected to the computer by the USB cable).
- ④ Apple “File Exchange” extension is not enabled.
 - Please refer to your Apple operating system manual for instructions on how to enable this extension.

- 2 Double-click the “Dcim” folder.

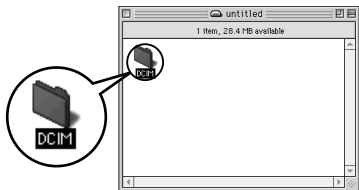

- 3 Double-click the “100OLYMP” folder.

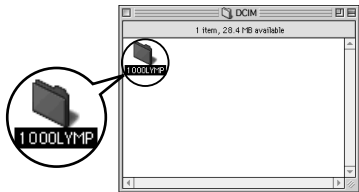
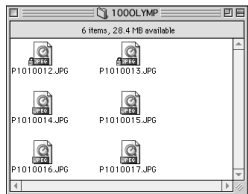
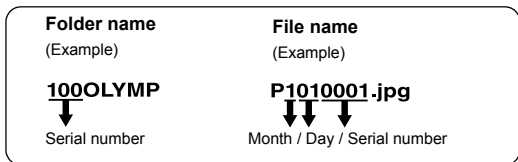

Image files (JPEG files) with file names such as “P1010001.JPG” are displayed.



- The camera automatically assigns folder names and file names according to the following rules.



- Serial numbers of image files run from 0001 to 9999.
- Serial numbers of folders run from 100 to 999.
- When file number 9999 is reached, a new folder is created and assigned the next number.
- Months January through September are expressed by the numbers 1 through 9, October by the letter A, November by B and December by C.

Macintosh

- 4 Double-click the “Macintosh HD” icon on the desktop.

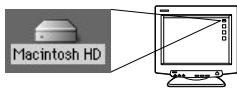

The “Hard Disk” window is displayed.

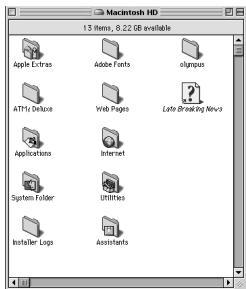

- 5** Drag & drop the image you want to save in the computer (in this case, P1010012.JPG) to the “Hard Disk” window.

The image is saved in the computer (in the Hard disk).

- To select all images, click Edit > Select all.

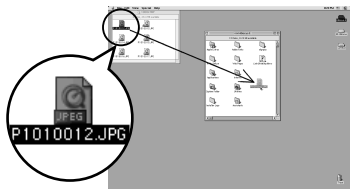

When the image file has been copied to the computer, you can view images by double-clicking the image files in the “Hard Disk” folder. The files will be opened in the default image viewer of the operating system. If you want to view the image a different size or process it, you will need to open the image with software that supports JPEG or TIFF images files, such as Paint Shop Pro, Photoshop or CAMEDIA Master software.



The lamp on the right of the viewfinder or the card access lamp blinks while the image is being copied. Never open the card cover on the camera, load or remove the batteries, or connect or disconnect the AC adapter while the lamp is blinking as the image files may be destroyed.

● Mac OS X

Malfunctions such as the following may occur due to the OS.

- If the camera is not connected correctly, a malfunction occurs in the computer.
- Date and time information of image files is not accurately displayed.
- If the card cover of the camera is opened while connecting to the computer, the “untitled” icon does not disappear from the desktop. etc.

When the computer has recognized the camera, the Apple Image Capture software dialog appears.

1 From the “Download To” menu, select a destination folder.

2 To download all images, click “Download All”.

To selectively download images, click “Download Some” and highlight the desired images.



The images are transferred from the camera to your computer.



If you are operating Mac OS X and you want to download images using the same procedure as for Mac OS 9, select “File > Close” and exit the Apple Image Capture software. At this time, the camera is indicated as “unlabeled”.



Caution

If you use the Apple Image Capture software, images downloaded to your computer and transferred back to a card may not play back on the camera or may have other problems.

Disconnecting the camera from your computer

- 1** Make sure that the lamp on the right of the viewfinder or the card access lamp is not blinking.

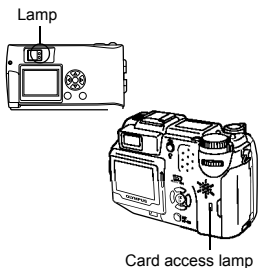

- 2** Drag the “untitled” icon on the desktop to “Trash”.



- 3** Make sure that the lamp on the right of the viewfinder or the card access lamp is not blinking.

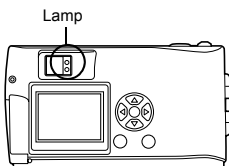

- 4** Remove the USB cable from the camera.

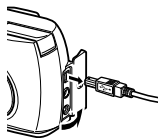

- 5** Remove the USB cable from your computer.

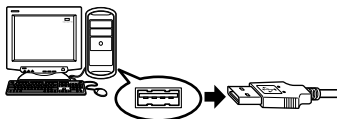

Downloading image files using other OS (For other OS users)

Users running other OS cannot connect the camera directly to a computer.

● **Windows 95** ● **Windows NT** ● **Mac OS before OS 9**

You can download images directly to your computer using an optional floppy disk adapter or PC card adapter.

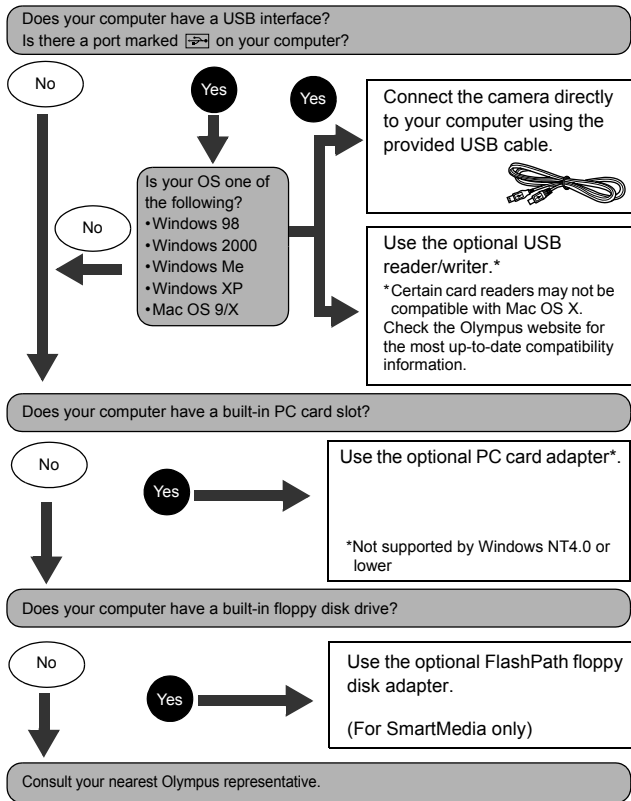

OLYMPUS

<http://www.olympus.com/>

OLYMPUS OPTICAL CO., LTD.

San-Ei Building, 22-2, Nishi Shinjuku 1-chome, Shinjuku-ku, Tokyo, Japan
Customer support (Japanese language only): Tel. 0426-42-7499 Tokyo

OLYMPUS AMERICA INC.

Two Corporate Center Drive, Melville, NY 11747-3157, U.S.A. Tel. 631-844-5000

Technical Support (USA)

24/7 online automated help: <http://support.olympusamerica.com/>

Phone customer support: Tel. 1-888-553-4448 (Toll-free)

Our phone customer support is available from 8 am to 10 pm
(Monday to Friday) ET

E-Mail: distec@olympus.com

Olympus software updates can be obtained at: <http://olympus.com/digital/>

Adobe [Photoshop] Support

Adobe software updates and technical information can be obtained at:
<http://www.adobe.com/support/>

OLYMPUS OPTICAL CO. (EUROPA) GMBH.

Premises/Goods delivery: Wendenstrasse 14-18, 20097 Hamburg, Germany
Tel. 040-237730

Letters: Postfach 10 49 08, 20034 Hamburg, Germany

Hotline Numbers for customers in Europe:

Tel. 01805-67 10 83

for Germany

Tel. 00800-67 10 83 00

for Austria, Belgium, Denmark, France,
Netherlands, Norway, Sweden, Switzerland,
United Kingdom

Tel. +49 180 5-67 10 83

for Finland, Italy, Luxembourg, Portugal,
Spain, Czech Republic

Tel. +49 40-237 73 899

for Greece, Croatia, Hungary, and the rest of Europe

Our Hotline is available from 9 am to 6 pm (Monday to Friday)

E-Mail: di.support@olympus-europa.com