

**1 YEAR**  
WARRANTY

MADE IN  
**USA**

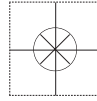

# User's Guide



*Shop online at*

**omega.com®**

Ω OMEGA®

*omega.com*

*e-mail: info@omega.com*

*For latest product manuals:*

*omegamanual.info*

**ISO 9001**  
CERTIFIED  
CORPORATE QUALITY

STAMFORD, CT

**ISO 9002**  
CERTIFIED  
CORPORATE QUALITY

MANCHESTER, UK

# FLR5000, 6000, 7000, 8000, and 9000 SERIES Flow Transmitter



OMEGAnet® On-Line Service  
omega.com

Internet e-mail  
info@omega.com

### **Servicing North America:**

**U.S.A.: ISO 9001 Certified**  
One Omega Drive, Box 4047  
Stamford, CT 06907-0047  
Tel: (203) 359-1660  
FAX: (203) 359-7700  
e-mail: info@omega.com

**Canada:**  
976 Bergar  
Laval (Quebec) H7L 5A1, Canada  
Tel: (514) 856-6928  
FAX: (514) 856-6886  
e-mail: info@omega.ca

### **For immediate technical or application assistance:**

**U.S.A. and Canada:**  
Sales Service: 1-800-826-6342 / 1-800-TC-OMEGA®  
Customer Service: 1-800-622-2378 / 1-800-622-BEST®  
Engineering Service: 1-800-872-9436 / 1-800-USA-WHEN®

**Mexico:**  
En Español: (001) 203-359-7803  
FAX: (001) 203-359-7807  
e-mail: espanol@omega.com  
info@omega.com.mx

### **Servicing Europe:**

**Czech Republic:**  
Frystatska 184, 733 01 Karviná, Czech Republic  
Tel: +420 (0)59 6311899  
FAX: +420 (0)59 6311114  
Toll Free: 0800-1-66342  
e-mail: info@omegashop.cz

**Germany/Austria:**  
Daimlerstrasse 26, D-75392  
Deckenpfronn, Germany  
Tel: +49 (0)7056 9398-0  
FAX: +49 (0)7056 9398-29  
Toll Free in Germany: 0800 639 7678  
e-mail: info@omega.de

**United Kingdom: ISO 9002 Certified**  
One Omega Drive  
River Bend Technology Centre  
Northbank, Irlam  
Manchester M44 5BD  
United Kingdom  
Tel: +44 (0)161 777 6611  
FAX: +44 (0)161 777 6622  
Toll Free in United Kingdom:  
0800-488-488  
e-mail: sales@omega.co.uk

---

It is the policy of OMEGA Engineering, Inc. to comply with all worldwide safety and EMC/EMI regulations that apply. OMEGA is constantly pursuing certification of its products to the European New Approach Directives. OMEGA will add the CE mark to every appropriate device upon certification.

The information contained in this document is believed to be correct, but OMEGA accepts no liability for any errors it contains, and reserves the right to alter specifications without notice.

**WARNING:** These products are not designed for use in, and should not be used for, human applications.

# FLR 5000, 6000, 7000, 8000, and 9000 Series Flow Transmitter Installation

## CAUTION

This product should be installed and serviced by technically qualified personnel trained in maintaining industrial class flow instrumentation and processing equipment.

## I. INTRODUCTION

The FLR Flow Transmitter is a state-of-the-art, micro-processor based variable area flow meter. It combines the rugged proven technology of a piston-type, variable area flow meter with solid state circuitry including:

- Non-contact sensor electronics
- Electronic signal conditioning circuit
- Digital flow rate and total indication
- Proportional analog output

The product is sealed against industrial contamination by a NEMA 12 and 13 (IP 52/54) rated enclosure and is available for either liquid or gas service.

The FLR Flow Transmitter is capable of calculating and displaying both flow rate and total accumulated flow. The flow rate and total flow can be displayed in any of the user selectable measurement units. The monitor's large 8 digit numeric liquid crystal display makes extended range viewing practical. The second 8 character alphanumeric display provides for selectable units viewing in RUN mode and prompts for variables in PROGRAM mode.

All FLR Flow Transmitters come pre-calibrated from the factory. However, the unit may be adjusted by the user to meet specific system requirements. Calibration parameters are included for:

- Specific gravity compensation (water or petroleum-based fluids)
- Pressure and temperature compensation (pneumatic applications)

## CAUTION

Read instructions thoroughly before installing the unit. If you have any questions regarding product installation or maintenance, call your local supplier for more information.

All meters include an analog output that can be configured for 0–5 Vdc, 0–10 Vdc, or 4–20 mA current loop.

Applications for the FLR Flow Transmitter include:

- Bearing lubrication
- Case drain verification
- Gun drill and machine cooling
- Pump flow outputs



**Figure 1. FLR Flow Transmitter**

## II. SPECIFICATIONS

### Enclosure Rating

- NEMA 12 & 13 (equivalent to IP 52/54)

### Operating Temperature

- Fluid: -20° to 240°F (-29° to 116°C)
- Ambient: -20° to 158°F (-29° to 70°C)

### Environmental

- Humidity: 0–90 % non-condensing

### Pressure (Aluminum / Brass Operating)

- Liquids (1/4" to 1-1/2"): 3500 psi (241 bar) maximum, with a 3:1 safety factor
- Gases (1/4" to 1-1/2"): 1000 psi (82 bar) maximum, with a 10:1 safety factor

### Pressure (Stainless Steel Operating)

- Liquids (1/4" to 1/2"): 6000 psi (414 bar) maximum, with a 3:1 safety factor
- Liquids (3/4" to 1-1/2"): 5000 psi (345 bar) maximum, with a 3:1 safety factor
- Gases (1/4" to 1-1/2"): 1500 psi (103 bar) maximum, with a 10:1 safety factor

### Accuracy

- $\pm 2\%$  of full scale

### Repeatability

- $\pm 0.5\%$

### Pressure Drop

See Appendix for specific transmitter information

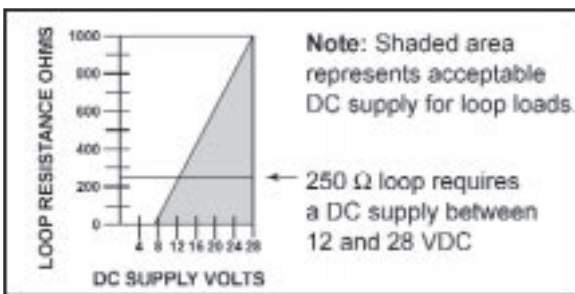

**Figure 2. Load Limitations (4-20 mA Output Only)**

## Electrical

### Power Requirement:

- 0–5 Vdc Output 10-30 Vdc @ 0.75W maximum
- 0–10 Vdc Output 12-30 Vdc @ 0.75W maximum
- 4–20 mA Output loop powered, 30 Vdc maximum

### Power Consumption:

- 25 mA maximum

### Analog Outputs:

- 0–5 Vdc and 0–10 Vdc into 10,000 Ohms minimum
- 4–20 mA into 1000 Ohms maximum (see Figure 2)

### Circuit Protection:

- Reverse polarity and current limiting

### Transmission Distance:

- 4–20 mA limited by cable resistance
- 0–5 Vdc 1000 feet (300 m) maximum
- 0–10 Vdc 1000 feet (300 m) maximum

### Isolation:

- Inherently isolated from the piping system

## Rate and Totalization Display

- Fixed or toggle modes of operation for rate and totalizer display
- 8 digit, .70" high numeric display for rate and total
- 8 digit, .35" high alphanumeric display for units and setup

## Temperature Drift

- 50 ppm/ °C (Max)

## Analog Output

- Resolution - 1:4000

## Transient Over-Voltages:

- Category 3, in accordance with IEC 664

## Pollution Degree:

- Category 2, in accordance with IEC 664

Additional dimension specifications can be found in Table 1 on page 3.

# FLR Flow Transmitter Installation & Programming Instructions

**Table 1 - Dimensions**

A Nominal Port Size	B Length in. (mm)	C Length in. (mm)	D Length in. (mm)	E Width in. (mm)	F Width in. (mm)	G Width in. (mm)	H Width in. (mm)	I Depth in. (mm)	J Offset in. (mm)	K Hole Dia. in. (mm)
1/4 (SAE 6)	6.60 (168)	5.27 (134)	6.41 (163)	6.00 (152)	3.23 (82)	3.00 (76)	4.20 (107)	2.94 (75)	1.51 (38)	.31 (8)
1/2 (SAE 10)	6.60 (168)	5.27 (134)	6.41 (163)	6.00 (152)	3.23 (82)	3.00 (76)	4.20 (107)	2.94 (75)	1.51 (38)	.31 (8)
3/4 (SAE 12)	7.20 (183)	5.27 (134)	7.04 (179)	6.00 (152)	3.60 (91)	3.00 (76)	4.20 (107)	2.94 (75)	1.27 (32)	.31 (8)
1 (SAE 16)	7.20 (183)	5.27 (134)	7.04 (179)	6.00 (152)	3.60 (91)	3.00 (76)	4.20 (107)	2.94 (75)	1.27 (32)	.31 (8)
1-1/4 (SAE 20)	12.20 (310)	10.68 (271)	11.65 (296)	7.63 (194)	4.84 (123)	3.82 (97)	5.02 (128)	4.50 (114)	2.20 (56)	.31 (8)
1-1/2 (SAE 24)	12.20 (310)	10.68 (271)	11.65 (296)	7.63 (194)	4.84 (123)	3.82 (97)	5.02 (128)	4.50 (114)	2.20 (56)	.31 (8)

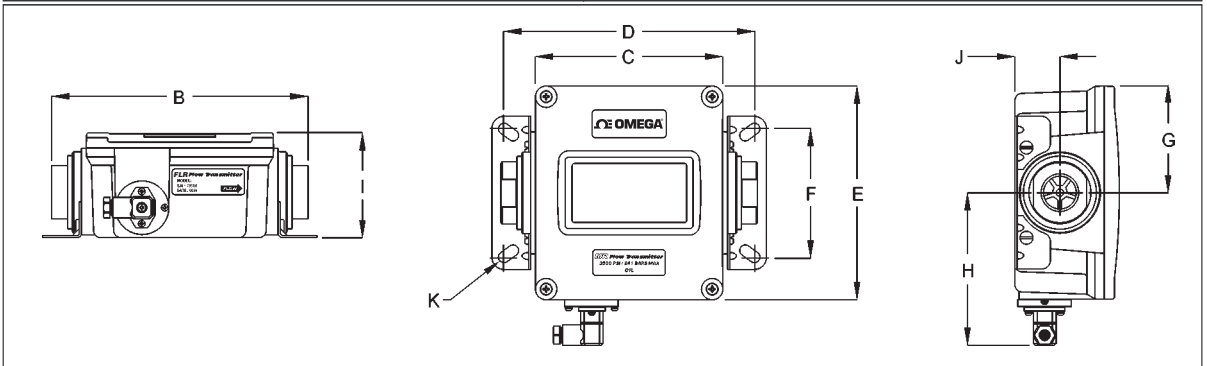

### III. INSTALLATION

This unit should be installed and serviced by technically qualified personnel trained in maintaining industrial class flow instrumentation and processing equipment.

#### **⚠ WARNING**

Disconnect electrical power before opening wiring enclosure. Failure to follow these instructions could result in serious personal injury or death and/or damage to the equipment.

#### **⚠ WARNING**

All wiring should be installed in accordance with the National Electrical Code and must conform to any applicable state and local codes. Failure to follow these instructions could result in serious personal injury or death and/or damage to the equipment.

#### **⚠ CAUTION**

Air/gas transmitters are NOT oxygen cleaned. Use with oxygen may cause hazardous or explosive conditions that may cause serious personal injury and/or equipment damage.

#### **⚠ CAUTION**

This transmitter may contain residual amounts of test fluid at the time of shipment. This fluid should be removed prior to installation as the fluid may be incompatible or hazardous with some liquids or gases. Failure to follow these instructions could result in damage to the equipment.

#### **⚠ CAUTION**

This standard transmitter is unidirectional. Attempts to flow fluids in the opposite direction of the flow arrow will result in the meter acting as a check valve, creating a deadheading situation. If the differential pressure magnitude is great enough, damage to the internal parts of the meter will result.

### **Installation Recommendations**

The transmitter is a simple device to install. However, the following measures are recommended for reliable, trouble-free operation:

**DO** - Align pipe accurately. Piping should be accurately aligned and of correct length. The high pressure body of the transmitter can withstand shock and flow/pressure pulsation. However, the piping should be firmly supported by external mounting brackets, both upstream and downstream of the meter, to avoid any pipe flexing action that could reduce meter life.

**DO** - Use rigid mounting. If the transmitter inlet or outlet are to be rigidly mounted, and the opposing port is to be connected to flexible hose, the end connected with the flexible hose must be rigidly mounted.

**DO** - Use Teflon<sup>®</sup> tape for sealing NPT fittings.

**DO** - Install unions. Install a union near the inlet or outlet of the transmitter. This will facilitate quick, easy removal and inspection during periodic maintenance procedures.

**DO** - Ensure the fluid is traveling in the direction of the flow arrow (Figure 5 on page 6).

**NOTE:** *The FLR Flow Transmitter display board can be rotated 180° for optimal viewing. Simply remove the FLR Flow Transmitter cover, disconnect the ribbon cable, rotate the display board 180°, reconnect the ribbon cable, and reinstall cover. See Figure 8 on page 7 for cover screw tightening sequence.*

**DO** - Use at least a 200 mesh (74 micron) filter. The transmitter will allow particulate to pass that would jam most valves and flow controls. Systems that do not have filtration should be equipped with at least a 200 mesh (74 micron) filter. Most hydraulic systems already have much finer filtration. Dirt, ferrous metal or sealing agents, such as Teflon tape may lodge and cause malfunction. If the transmitter is jammed at a fixed position, follow cleaning and maintenance instructions. See Maintenance section on page 14.

**DON'T** - Use thread locking compounds as thread sealant.

**DON'T** - Install the transmitter near turbulence producing fittings such as elbows, reducers, close coupled valves, etc. The transmitter does not require flow straighteners or special lengths of straight inlet/outlet piping to stabilize turbulent flow patterns. However, to assure maximum operational reliability, avoid installation of elbows, valves and/or reducers immediately adjacent to the transmitter inlet.

**DON'T** - Install the transmitter near fast-acting valves. Fast-acting valves have the potential to create high magnitude hydraulic pressure spikes. These spikes can damage the internal components of the transmitter, resulting in inaccuracies or malfunction.

**DON'T** - Allow unidirectional transmitters to be operated against the direction of the flow arrow. The standard transmitter is a unidirectional flow transmitter. The piston acts as a check valve to block flow in the reverse direction. This causes an excessive pressure differential, which can result in damage to internal transmitter components. The transmitter is also available in a modified design, which offers a reverse flow bypass feature to accommodate bi-directional flow.

**NOTE:** *Transmitters with a reverse flow bypass feature are available. Consult factory for details.*

### **Electrical Connections**

Cable may be shortened or lengthened as required by installation. The cable is soldered directly to the electrical connector at the factory.

Cable replacement requires disassembly of the electrical connector.

# FLR Flow Transmitter Installation & Programming Instructions

## Schematics

The transmitter can be wired in various configurations to allow interface with many different types of data collection and control instrumentation.

Schematics 1 & 2 represent typical wiring for a target powered by either AC power or DC supply. Schematics 3 & 4 will be utilized when the flow transmitter is operated with loop-powered process indicators or data loggers that do not have external sensor excitation available.

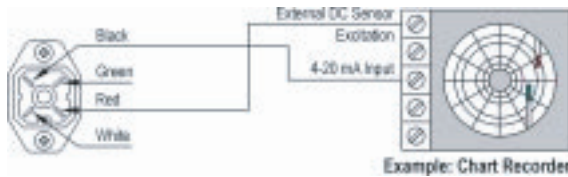

Schematic 1: 4-20 mA connection using target power supply

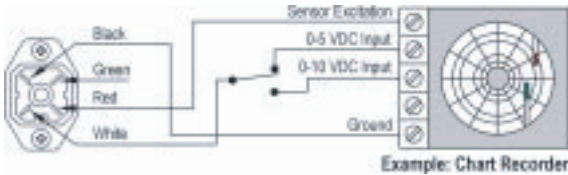

Schematic 2: 0-5 Vdc or 0-10 Vdc connection using target power supply

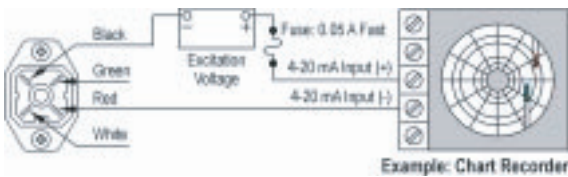

Schematic 3: 4-20 mA connection using external power supply

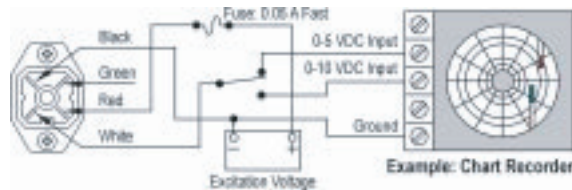

Schematic 4: 0-5 Vdc or 0-10 Vdc connection using external power supply

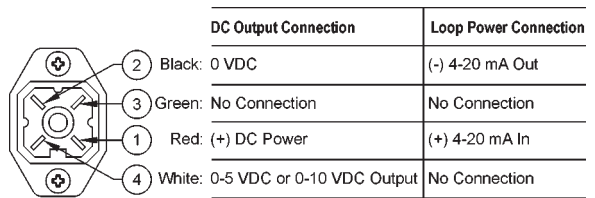

Figure 3. Electrical 4-Pin Connection

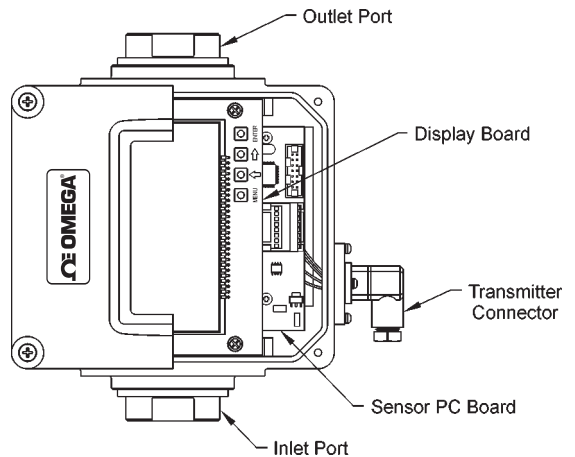

Figure 4. Terminology

### ⚠ CAUTION

The flow transmitter is designed to operate only one of its three outputs at a time (i.e., 0-5 Vdc or 0-10 Vdc or 4-20 mA). Connecting multiple outputs simultaneously will result in inaccurate output signal levels.



## FLR Flow Transmitter Installation & Programming Instructions

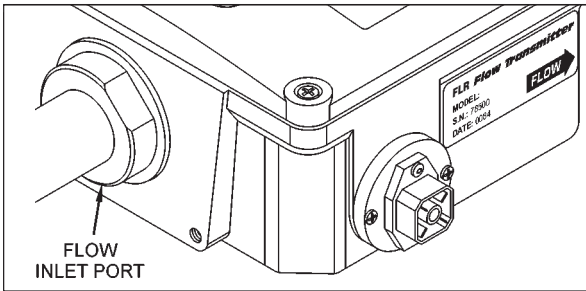

Figure 5. Flow Direction Arrow

### Installing the Transmitter

1. Disconnect electrical power from the target system before making or changing any transmitter connections.
2. Use 0.05A fast acting fuse if non-current limited power sources are utilized.
3. Terminate cable shield connection at either DC ground or Earth ground.
4. Mount the transmitter so fluid is traveling in the direction of the flow arrow. See Figure 5.
5. Install unit in desired location. Use wrench on transmitter flats to hold the unit in place during installation. DO NOT TURN the transmitter using the wrench. See Figure 6.
6. After installation, rotate transmitter by hand to view display. See Figure 7.
7. Capture the zero flow position on the meter cone using the ZERO CAPTURE procedure found on page 12.

## IV. OPERATION

**NOTE:** Refer to the Appendix for application information and fluid charts.

### Operating the Meter

The monitor has two modes of operation, referred to as RUN mode and PROGRAM mode as indicated on the display screen readout. Normal operation will be in the run mode. To access the program mode, press the MENU key until the first programming screen DISPLAY appears. (PROGRAM appears on left side of

Place wrench on transmitter flats on the same side plumbing is being tightened

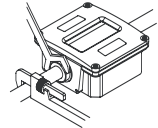

Never place wrench on transmitter flats opposite plumbing being tightened

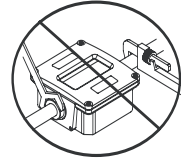
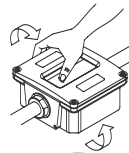

Figure 6. Installing Transmitter

Rotate transmitter by hand to view flow display



Never use wrench to rotate transmitter body when viewing flow display

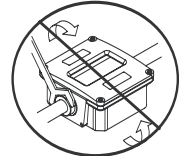

Figure 7. Rotating Transmitter

display.) After programming the meter a password may be entered to prevent unauthorized access or changing of the setup features.

### Normal Operation (RUN) Mode

During normal operation, the display will show RUN and the flow rate, total flow, or toggle back and forth between the two as defined by the DISPLAY configuration.

The 4 buttons have the following function in RUN mode:

MENU - Selects programming mode.

UP ARROW - No function.

RIGHT ARROW - No function.





## Programming Procedures

The FLR Transmitter allows two basic sets of programming procedures: list item selection and entering numeric values.

### List Item Selection Procedure

**Note:** *If you are already in PROGRAM mode and the selection to be viewed or changed is already displayed, proceed to step 3 below. If you are in PROGRAM mode and the selection to be viewed or changed is not displayed, press the UP or RIGHT ARROW key and repeat pressing until the desired selection appears. Proceed to step 3.*

1. Press MENU.

PROGRAM appears in the lower left-hand corner and DISPLAY appears.

2. Press the UP ARROW or RIGHT ARROW key to move to the desired selection.
3. Press ENTER to view the current selection.
- 4a. If the current selection is desired, press ENTER to confirm.

The unit will automatically advance.

- 4b. If current selection must change, press either arrow key to scroll through the available choices. Press ENTER to confirm your selection.

The unit will automatically advance.

5. To exit programming, press the MENU button.

The display will change to RUN mode.

### Numeric Value Entry Procedure

**Note:** *If you are already in PROGRAM mode and the desired selection is displayed, proceed to step 3 below. If you are in PROGRAM mode and the desired selection is not displayed, press the UP or RIGHT ARROW key and repeat pressing until the desired selection appears. Proceed to step 3.*

1. Press MENU.

PROGRAM appears in the lower left-hand corner and DISPLAY appears.

2. Press UP or RIGHT ARROW key until the desired selection displays.

The current numeric value for this selection appears in the upper section of the display.

- 3a. If the current displayed value is desired, press ENTER. The left most programmable number begins to flash. Press ENTER again to confirm and keep the current setting.

The unit will automatically advance.

- 3b. If current selection must change, press ENTER. The left most programmable number begins to flash. Use the UP ARROW key to scroll through the digits 0–9 and change the flashing digit to the desired value. Use the RIGHT ARROW key to move the active digit to the right. Continue using the UP and RIGHT ARROW keys until all desired digits are selected.

4. Press ENTER to confirm your selection.

The unit will automatically advance.

5. To exit programming mode, press the MENU key.

The display will change to RUN mode.

**Programming Flow Chart**

The programming flow chart on pages 10 and 11 will aid understanding of the menu structure of the FLR Flow Transmitter. It will also help with understanding the available configuration selections.

**Programming Descriptions**

**Display Mode**

The meter can display RATE (flow rate) or TOTAL (total accumulated flow) or alternate between BOTH rate and total. Its displayed name is DISPLAY and is viewed or changed using the List Item Selection Procedure found on page 8.

**Rate Units of Measure**

The meter allows the selection of many common rate units. Its displayed name is RATE UNT and is viewed or changed using the List Item Selection Procedure found on page 8.

**Rate (Time) Interval**

The meter allows selection of several intervals based on time. Its displayed name is RATE INT and is viewed or changed using the List Item Selection Procedure found on page 8.

**Total Units of Measure**

If the total flow is being displayed, the units for the total must first be chosen. The monitor allows the choice of many common totalization units. Its displayed name is TOTL UNT and is viewed or changed using the List Item Selection Procedure found on page 8.

**Total Display Multiplier**

The meter has the ability to accumulate the flow total in multiples of ten. For example, if the most desirable totalization unit is 1,000 gallons, the monitor can easily be set up for this requirement. Once back in RUN mode every time the total display increments by one digit the actual total would be an additional 1,000 gallons. At 1,000 total gallons the total display would read 1, at 3,000 gallons the total display would read 3, etc. This feature allows the unit to accumulate totals that would exceed the 8 digit display capacity. Table 2 lists the available selection choices. Its displayed name is TOTL EXP and is viewed or changed using the List Item Selection Procedure found on page 8.

**Table 2 - Total Flow Units**

E-2	Total display number indicates increments of 0.01 unit
E-1	Total display number indicates increments of 0.1 unit
E0	Total display number indicates increments of 1 unit
E1	Total display number indicates increments of 10 units
E2	Total display number indicates increments of 100 units
E3	Total display number indicates increments of 1,000 units
E4	Total display number indicates increments of 10,000 units
E5	Total display number indicates increments of 100,000 units
E6	Total display number indicates increments of 1,000,000 units

**Scale Factor**

The scale factor is used to span the meter. Its displayed name is SCALE F and is viewed or changed using the Numeric Value Entry Procedure found on page 8.

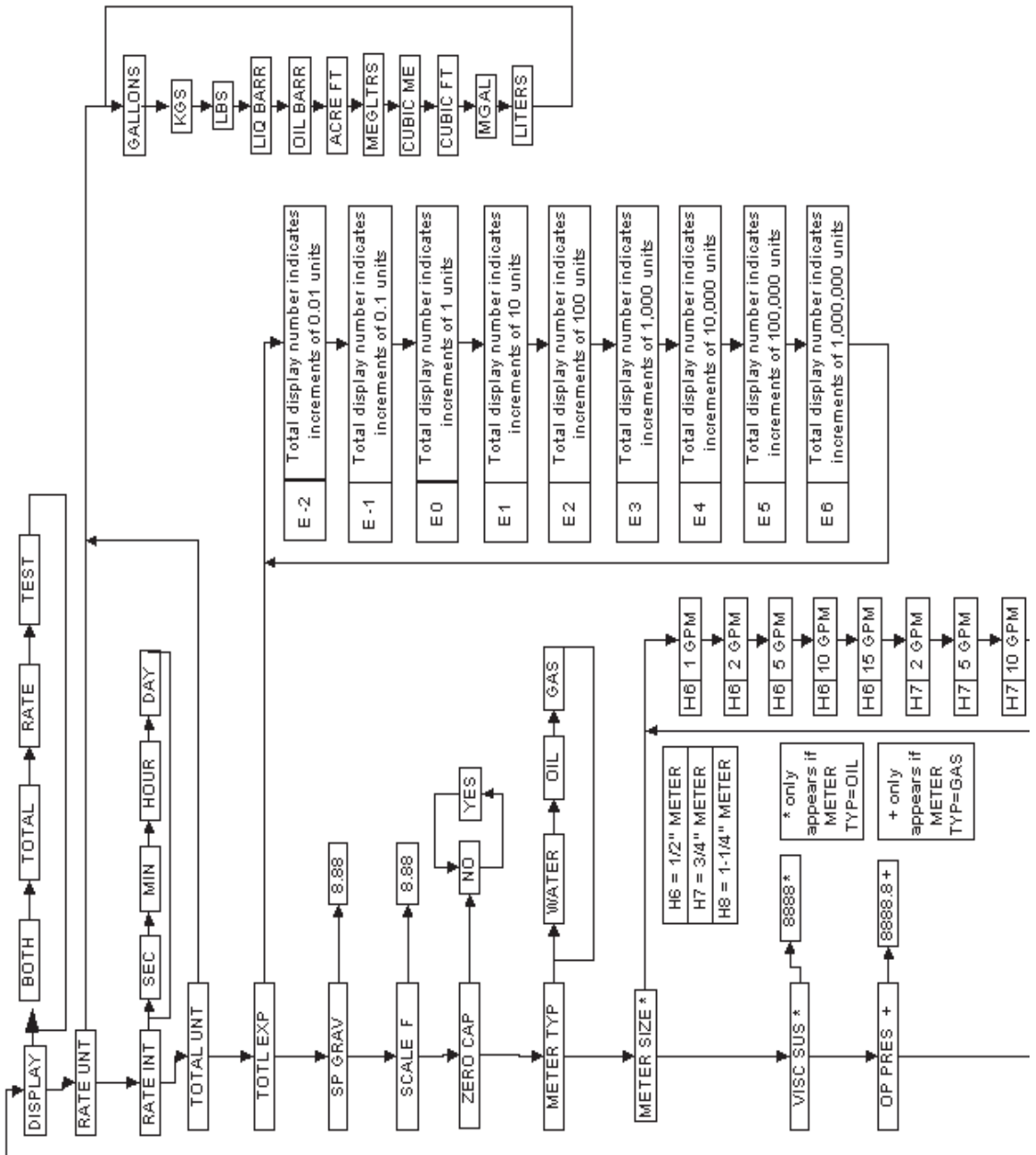

# FLR Flow Transmitter Installation & Programming Instructions

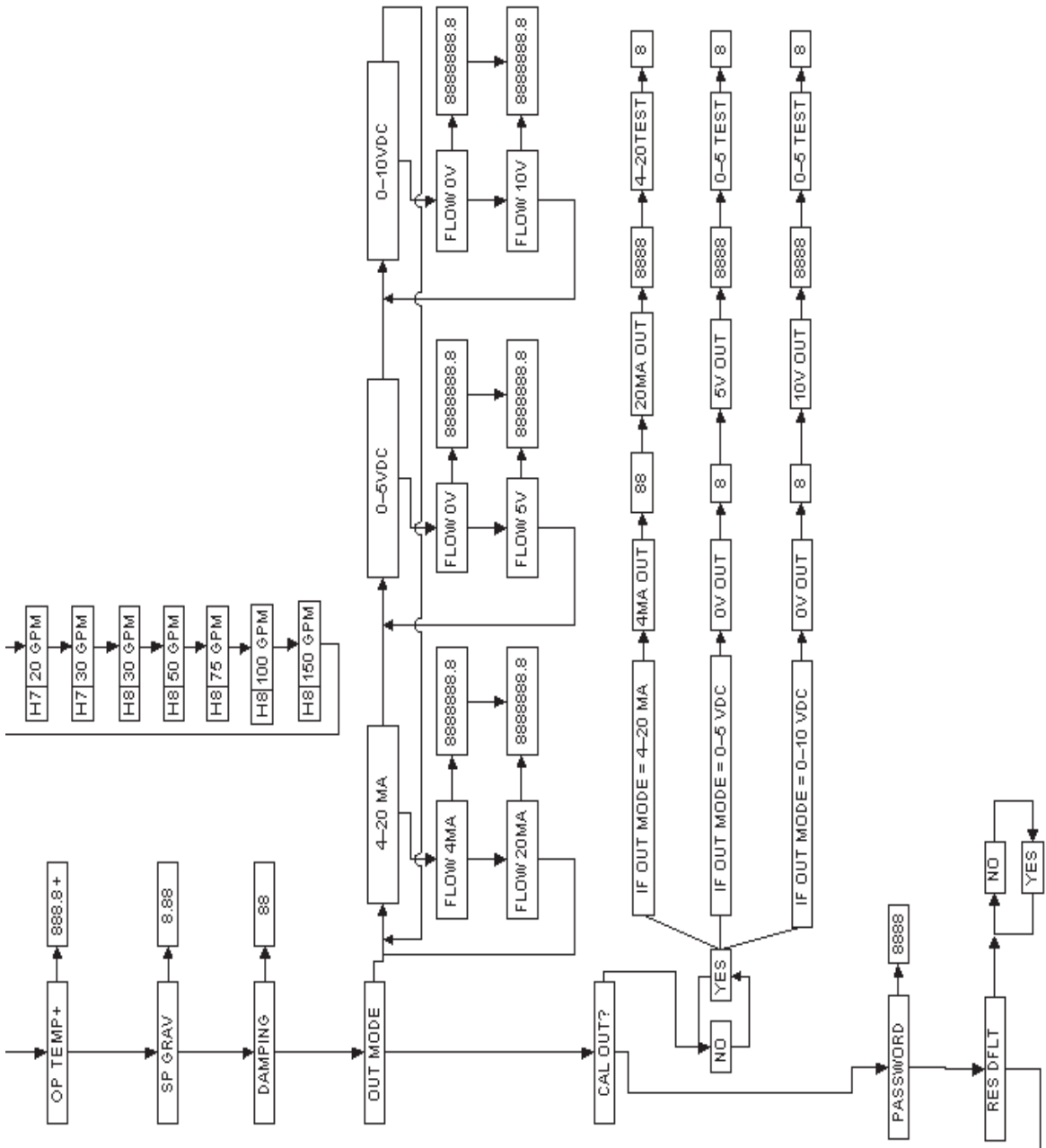

**Zero Capture**

The zero position of the meter cone must be set when installing the meter. To capture the zero calibration position, press ENTER at the ZERO CAP prompt. NO will display. Press either arrow key to change to YES, then press ENTER to capture zero.

**Meter Type**

The meter can be programmed to compensate for specific gravity, pressure, and temperature depending upon the application. Its displayed name is METER-TYP and is viewed or changed using the List Item Selection Procedure found on page 8.

**Note:** Refer to Flow Chart on pages 10 and 11. When Meter Type WATER is selected, specific gravity (SP GRAV) will automatically follow.

**Note:** Refer to Flow Chart on pages 10 and 11. When Meter Type OIL is selected, meter size (METERSIZ), viscosity (VISC SUS), and specific gravity (SP GRAV) will automatically follow.

**Note:** Refer to Flow Chart on pages 10 and 11. When Meter Type GAS is selected, operating pressure (OP PRESS), operating temperature (OP TEMP), and specific gravity (SP GRAV) will automatically follow.

**Meter Size**

Meter size is used in conjunction with Viscosity to perform viscosity correction. Table 3 lists the available selection choices. Its displayed name is METERSIZ and is viewed or changed using the List Item Selection Procedure found on page 8.

<b>Table 3 - Meter Size Types</b>		
<b>1/4" &amp; 1/2" meter</b>	<b>3/4" &amp; 1" meter</b>	<b>1 1/4" &amp; 1 1/2" meter</b>
1GPM	2GPM	30GPM
2GPM	5GPM	50GPM
5GPM	10GPM	75GPM
10GPM	20GPM	100GPM
15GPM	30GPM	150GPM

**Viscosity**

Viscosity is used in conjunction with the Meter Size to perform viscosity correction when the Meter type selected is OIL. Enter in SUS units the viscosity of the oil that will be used. Its displayed name is VISC SUS and is viewed or changed using the Numeric Value Entry Procedure found on page 8.

**Operating Pressure**

The operating pressure is used in gas applications to compensate for the actual pressure being measured at the meter. Enter the operating pressure in PSI units. Its displayed name is OP PRES and is viewed or changed using the Numeric Value Entry Procedure found on page 8.

**Operating Temperature**

The operating temperature is used in gas applications to compensate for the actual temperature of the gas being measured at the meter. Enter the operating temperature in °F units. Its displayed name is OP TEMP and is viewed or changed using the Numeric Value Entry Procedure found on page 8.

**Specific Gravity Correction Factor**

Specific Gravity is used to compensate for the specific gravity of the liquid or gas being measured with the meter. Its displayed name is SP GRAV and is viewed or changed using the Numeric Value Entry Procedure found on page 8.

**Damping**

The Damping factor is increased to enhance the stability of the flow readings. Damping values are decreased to allow the flow meter to react faster to changing values of flow. This parameter can range from 0 to 99; factory default is 0. Its displayed name is DAMPING and is viewed or changed using the Numeric Value Entry Procedure found on page 8.

### **Output Mode**

The FLR Flow Transmitter offers three analog output modes:

- 4–20 mA Output Signal
- 0–5 Volts DC Output Signal
- 0–10 Volts DC Output Signal

The output mode selected is determined by the type of peripheral device being connected to the FLR Flow Transmitter.

The displayed name is OUT MODE and is viewed or changed using the List Item Selection Procedure found on page 8.

***Note:** Setup prompts and descriptors for configuring and calibrating the analog output will correspond to the output mode selected. Refer to the Flow Chart on pages 10 and 11.*

#### **Flow at 0V or 4mA Setting**

This selection is used to configure the minimum analog output signal to the corresponding flow rate. Enter the flow rate at which the minimum analog output signal is required using the Numeric Value Entry Procedure found on page 8.

#### **Flow at 5V, 10V or 20mA Setting**

This selection is used to configure the maximum analog output signal to the corresponding flow rate. Enter the flow rate at which the maximum analog output signal is required using the Numeric Value Entry Procedure found on page 8.

### **Calibration of Analog Output**

This selection allows access to the calibration and testing of the analog output signal. Calibration of the Analog Output is preset at the factory, but can be changed to customize calibration for your installation.

To test or change the analog output calibration, it is first necessary to change the default setting for CAL OUT? from NO to YES.

***Note:** Setup prompts and descriptors for configuring and calibrating the analog output will correspond to the output mode selected. Refer to the Flow Chart on pages 10 and 11.*

1. At the CAL OUT? prompt press ENTER. NO will display.
2. To change to YES, press either arrow key.
3. The analog output will go to its minimum output level. A numeric value between 0–4000 will display. This is an internal number used to drive the analog output.
4. To increase the analog output signal level, press the UP ARROW key. To decrease the analog output signal level, press the RIGHT ARROW key.
5. Press ENTER to store the setting.
6. The analog output will go to its maximum output level. A numeric value between 0–4000 will display. This is an internal number used to drive the analog output.
7. To increase the analog output signal level, press the UP ARROW key. To decrease the analog output signal level, press the RIGHT ARROW key.
8. Press ENTER to store the setting.
9. The unit will advance to the analog output test mode. The analog output will go to its minimum output level. A numeric value of 0 will display. For test purposes, the analog output signal can be run up or down in increments of 1 milliamp or 1 volt, depending on the OUT MODE selected.
10. To increase the analog output signal level, press the UP ARROW key. To decrease the analog output signal level, press the RIGHT ARROW key.
11. Press ENTER to exit the analog calibration mode.
12. The unit automatically advances to the PASS-WORD feature.



### Password

Password protection prevents unauthorized users from changing programming information. Initially the password is set to all zeros. Its displayed name is PASSWORD and is viewed or changed using the Numeric Value Entry Procedure found on page 8.

### Restore Defaults

This feature allows you to restore factory calibration data. Its displayed name is RES DFLT. To restore factory calibration data, select YES, then press ENTER.

## V. MAINTENANCE

### WARNING

Before attempting to remove the transmitter from the line, check the system to confirm that line pressure has been reduced to zero PSI. Failure to follow these instructions could result in serious personal injury or death and/or damage to the equipment.

### WARNING

Always disconnect the primary power source before opening the enclosure for inspection or service. Failure to follow these instructions could result in serious personal injury or death and/or damage to the equipment.

### Cartridge Cleaning (Figure 4 on page 5 and Figure 9 on page 15)

1. Disconnect the transmitter cable.
2. Remove the transmitter from the line. Remove excess piping from transmitter.

**NOTE:** *It is not necessary to remove the aluminum housing from the transmitter to remove it from the line.*

3. Thoroughly wipe off the entire transmitter surface using mild detergent or isopropyl alcohol.

### WARNING

Do not use aromatic hydrocarbons, halogenated hydrocarbons, ketones, or ester based fluids on polycarbonate lens. Failure to follow these instructions could result in damage to the transmitter.

4. Remove the inlet port cap, wave spring, retaining ring, and cone assembly from the transmitter body (Figure 9 on page 15).
5. Gently push the body towards the outlet port.
6. The piston, inner magnet and transmitter spring are secured within the transmitter body with a retaining ring. Remove the retaining ring with a small screwdriver, then the internal components can be removed from the body (Figure 9 on page 15).

**NOTE:** *If internal parts do not slide freely from cartridge, use a wooden dowel inserted into the outlet port of the transmitter to push parts out.*

7. Place all parts on a clean work surface. Clean and inspect all parts. Replace any that appear worn or damaged.  
  
Check inlet port O-ring for damage and replace if required.
8. Reassemble the transmitter by inserting the transmitter spring into the body, followed by the piston/inner magnet assembly. A slight compression of the piston against the spring is required during installation of the retaining ring.
9. Gently push body assembly into the outlet end of the transmitter enclosure. The flat surface of the body outlet port should be flush with the transmitter enclosure opening.
10. With the transmitter positioned vertically on a flat surface, inlet port facing up, install the transmitter cone assembly and wave spring into the body and secure with the inlet port end cap.
11. Reinstall transmitter to the line. Reconnect electrical power.

**Inspection**

1. Frequent inspection should be made. The environment and frequency of use should determine a schedule for maintenance checks. It is recommended that it should be at least once a year.
2. Perform visual, electrical, and mechanical checks on all components on a regular basis.
3. Visually check for undue heating evidence such as discoloration of wires or other components, damaged or worn parts, or leakage evidence such as water or corrosion in the interior.
4. Electrically check to make sure that all connections are clean and tight and that the device is wired properly.

**VI. TROUBLESHOOTING**

**No LCD display**

- For 4–20 mA operation, check for current flow in the loop.
- Check polarity of the current loop connections for proper orientation.
- For 0–5 V or 0–10 V operation, check for proper voltage being supplied to the unit.
- Check polarity of the supply voltage.

**No rate or total displayed**

- Check flow meter cone for debris. Cone should move inside the tube freely.
- Check setup programming of flow meter.

**Unstable Flow Reading**

- This usually indicates pulsing or oscillation in the actual flow. Increase the DAMPING parameter to increase the filtering in order to provide a more stable display reading.

**VII. APPENDIX**

**Application Information – Liquid**

**Viscosity Effect (SUS/cSt)**

The design utilizes a precision machined, sharp-edged orifice and biasing calibration spring that assures operating stability and accuracy over the wide viscosity range common to many fluids. Generally, high flow

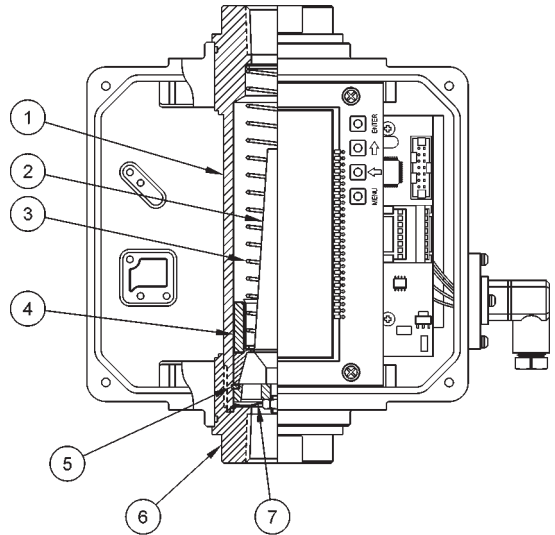

1. BODY
2. CONE ASSEMBLY
3. METER SPRING
4. PISTON ASSEMBLY
5. RETAINING RING
6. CAP
7. WAVE SPRING

**Figure 9. Cartridge Components**

models of each transmitter size provide good accuracy over a viscosity range of 40 to 500 SUS (4.2 to 109 cSt).

**Density Effect (specific gravity)**

Any fluid density change from stated standards has a proportionate effect on transmitter accuracy. Corrections for more or less dense fluids can be made to standard scales using the following correction factor:

$$\frac{1.0}{\sqrt{\text{Specific Gravity}}} \text{ for water/water-based transmitters}$$

$$\frac{0.876}{\sqrt{\text{Specific Gravity}}} \text{ for petroleum-based transmitters}$$

**Application Information – Pneumatic**

**NOTE:** Pressure and temperature readings must be taken at the flow transmitter inlet to ensure accurate correction factors.

The pneumatic flow transmitter is calibrated for air in standard cubic feet per minute (scfm) at 1.0 s.g. (70°F @ 100 psi), and liters per second (lps) at 1.0 s.g. (21°C @ 6.9 bar).

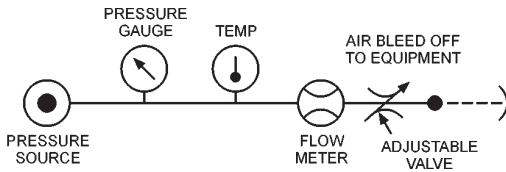

**Figure 10. System Schematic**

**Table 4 - Correction Factors**

FLOW RATE CORRECTION FACTORS FOR GAS										
$\text{SCFM (Actual)} = \frac{\text{SCFM (Indicated)}}{f_1 \times f_2 \times f_3}$ <p style="margin-left: 20px;"> <math>f_1</math> = conversion factor for inlet pressure  <math>f_2</math> = conversion factor for temperature  <math>f_3</math> = conversion factor for specific gravity                 </p>										
PRESSURE CORRECTION FACTOR ( $f_1$ )										
Operating Pressure (psig)										
psig	25	50	75	100	125	150	175	200	225	250
$f_1$	1.700	1.331	1.131	1.00	.902	.835	.778	.731	.692	.658
$f_1 = \sqrt{\frac{114.7}{14.7 + \text{psig}}}$										
TEMPERATURE CORRECTION FACTOR ( $f_2$ )										
°F	10	30	50	70	90	110	130	150	170	190
$f_2$	.942	.962	.981	1.00	1.018	1.037	1.055	1.072	1.090	1.107
$f_2 = \sqrt{\frac{460 + \text{°F}}{530}}$										
SPECIFIC GRAVITY CORRECTION FACTOR ( $f_3$ )										
$f_3 = \sqrt{\text{Specific Gravity}}$										

**Table 5 - Fluid Selection**

Air / Gas	Specific Gravity	Correction Factor Std. Scale	Aluminum	Brass	T316 SS	T303 SS	Viton	EPR	Polycarbonate	Nylon	Pyrex™
Air	1.0	1.000	R	R	R	R	R	R	R	R	R
Argon (A)	1.38	1.175	R	R	R	R	R	R	R	R	R
Carbon Dioxide (CO <sub>2</sub> )	1.53	1.237	R	R	R	R	R	R	R	R	R
Freon 11 (CCl <sub>3</sub> F)	4.92	2.218	R	R	R	R	R	R	R	R	R
Freon 12 (CCl <sub>2</sub> F)	4.26	2.060	R	R	R	R	R	R	R	R	R
Helium (HE)	0.14	0.374	R	R	R	R	R	R	R	R	R
Hydrogen (H <sub>2</sub> )	0.07	0.265	R	R	R	R	R	R	R	R	R
Natural Gas	0.60	0.775	C	C	R	C	R	N	C	R	R
Nitrogen (N <sub>2</sub> )	0.97	0.985	C	C	R	R	R	R	C	R	R
Oxygen (O <sub>2</sub> )	1.10	1.049	R	R	R	R	R	R	R	R	R
Propane (C <sub>3</sub> H <sub>8</sub> )	1.57	1.253	R	R	R	R	R	N	N	R	R

R = Recommended  
 N = Not recommended  
 C = Consult Factory

**Note:** Table 4 is included to show the correction algorithms included in the program to perform pressure, temperature, and specific gravity corrections. When configuring the FLR Flow Transmitter, enter the actual operating pressure, temperature, and specific gravity values, **not** the correction factors.

## Flow vs. Pressure Drop

### Water Based Fluids

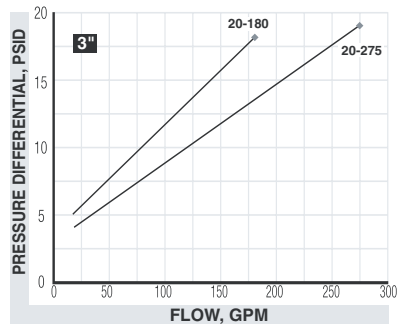
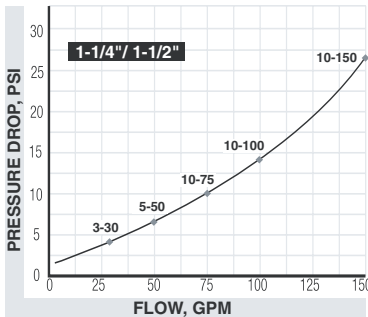
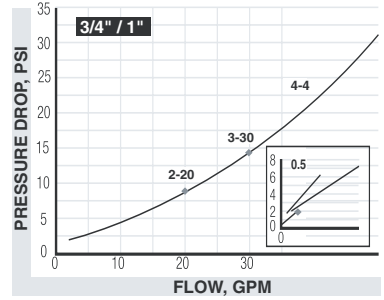
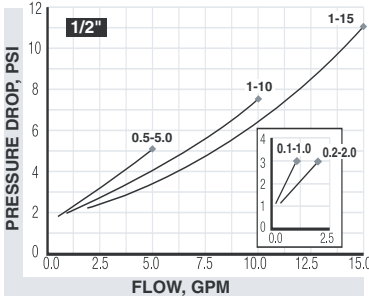
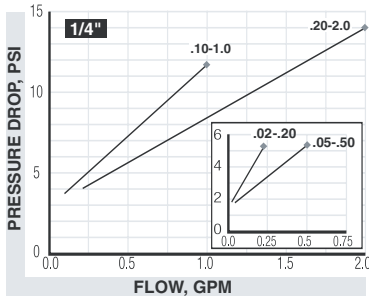

### Water Based Fluids (continued)

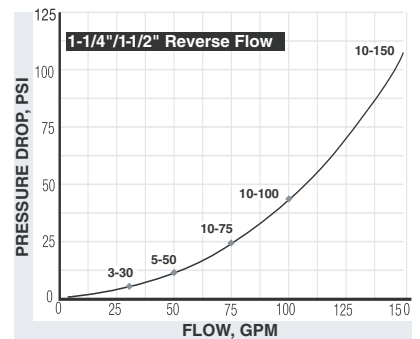
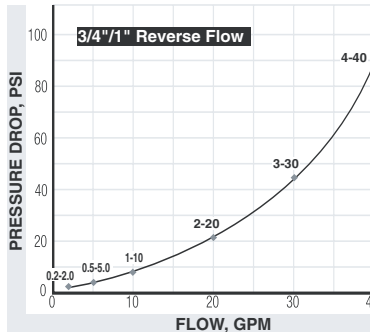
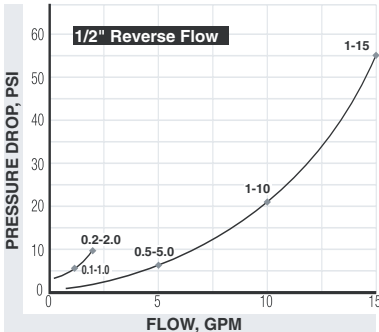

# FLR Flow Transmitter Installation & Programming Instructions

## Water

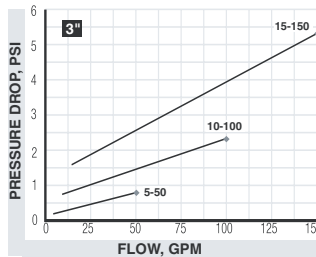
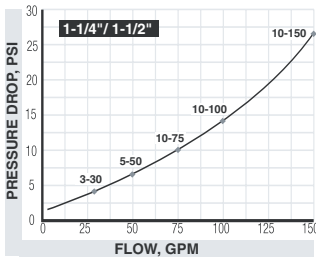
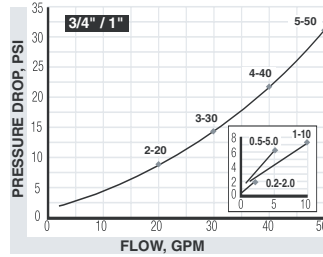
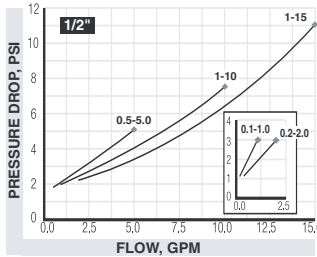
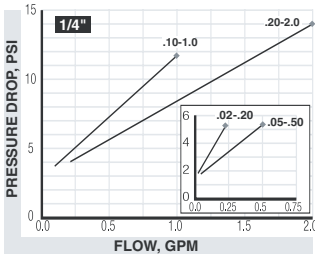

Note: Calibrated with 140 SUS (32 cSt), 0.876 s.g. hydraulic oil  
Flow meter scales are corrected for 1.00 s.g. fluid

## Caustic and Corrosive Liquids

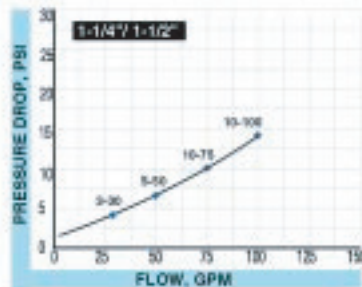
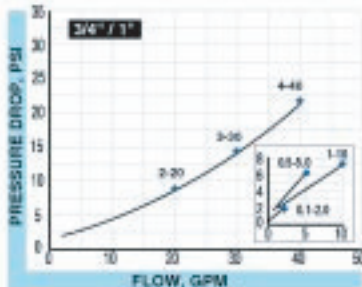
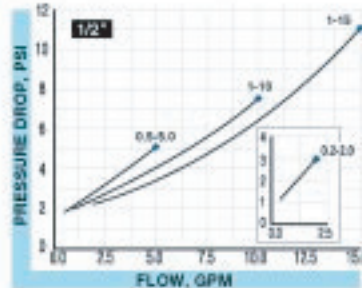
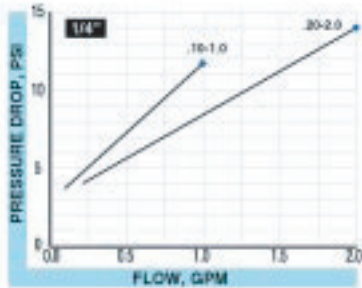

# FLR Flow Transmitter Installation & Programming Instructions

## Petroleum Fluids

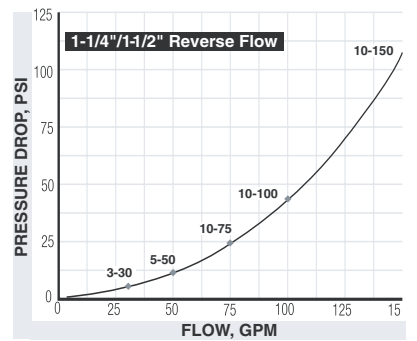
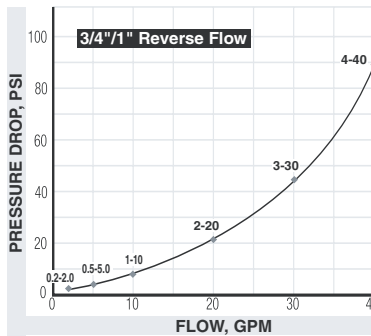
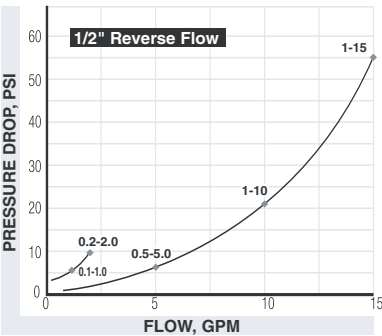
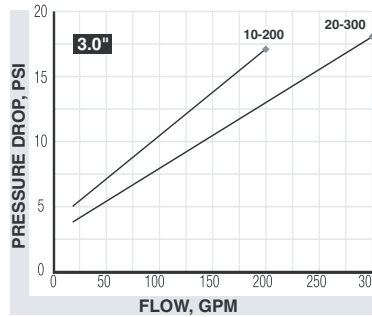
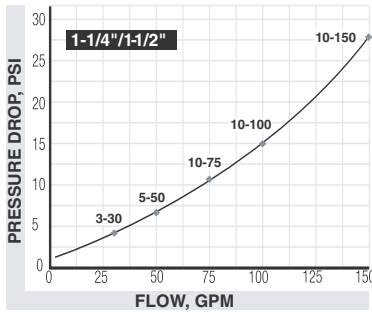
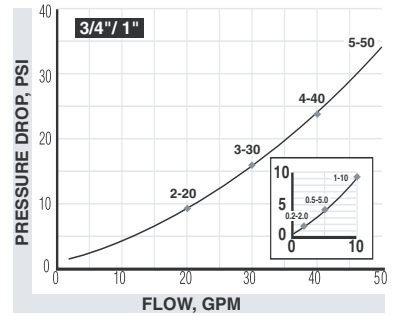
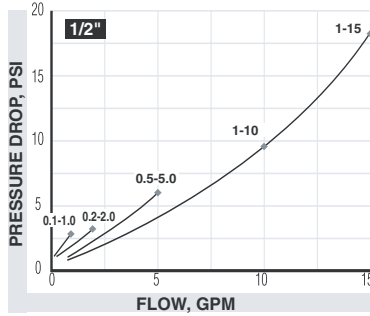
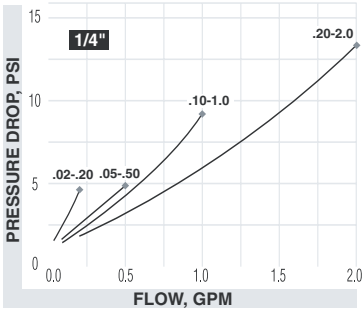

# FLR Flow Transmitter Installation & Programming Instructions

## Phosphate Ester

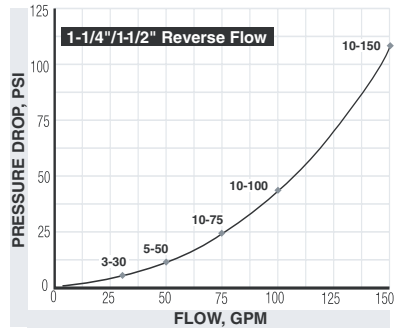
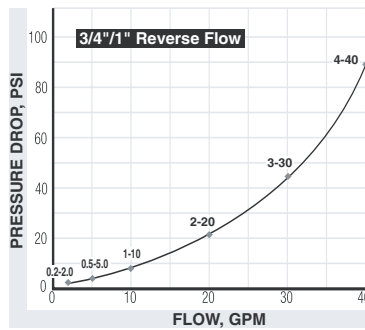
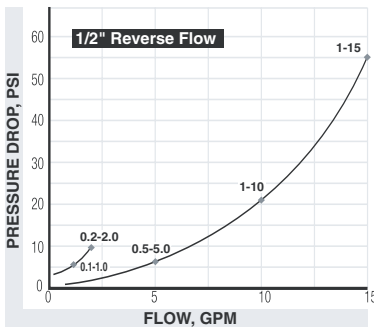
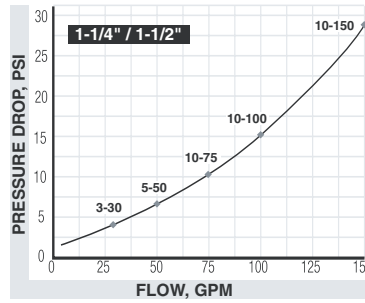
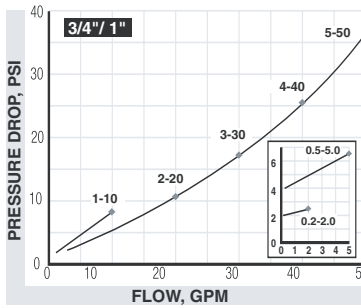
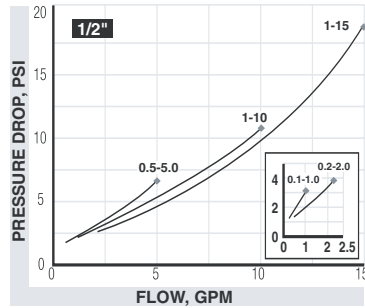
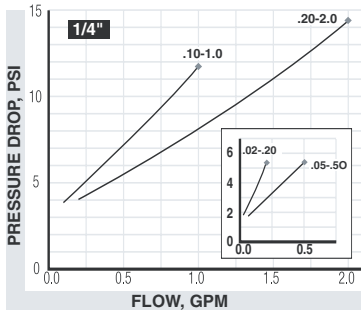



# FLR Flow Transmitter Installation & Programming Instructions

## A.P.I. Oil

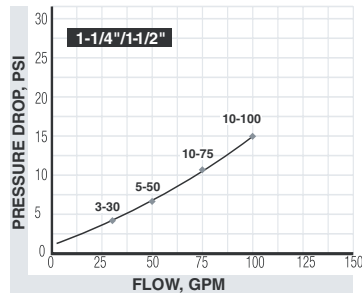
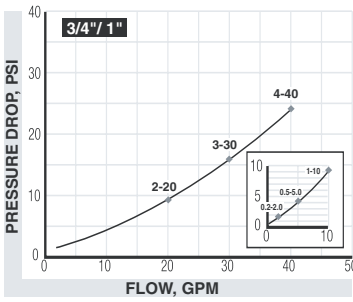
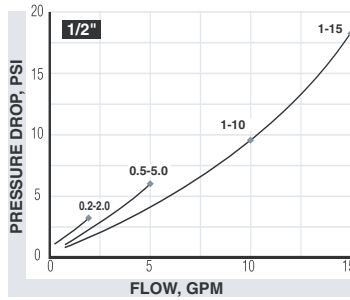
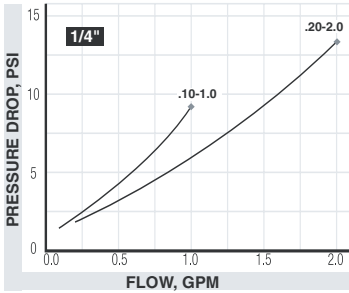

## Air / Caustic and Corrosive Gases

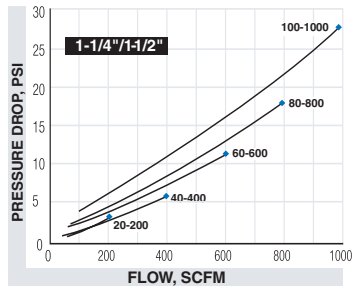
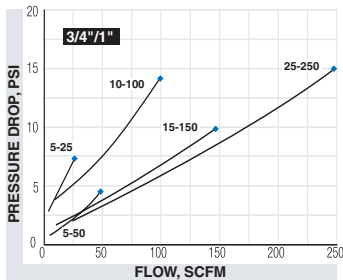
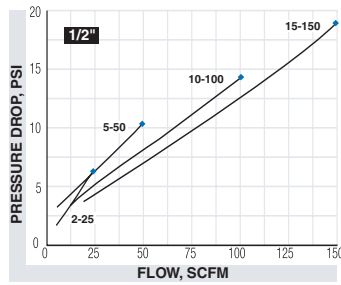
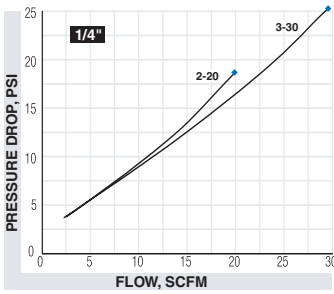

# FLR Flow Transmitter Installation & Programming Instructions

## Air / Compressed Gases

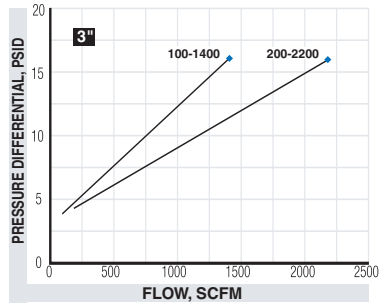
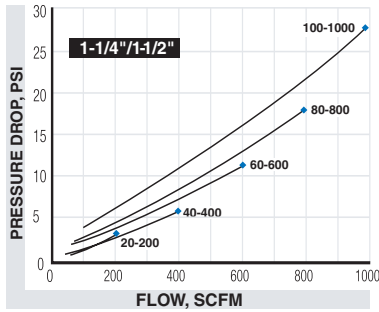
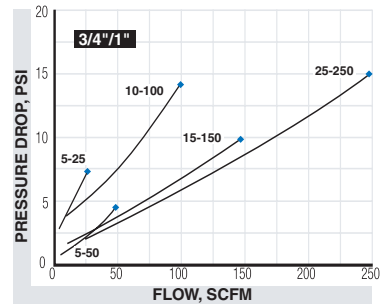
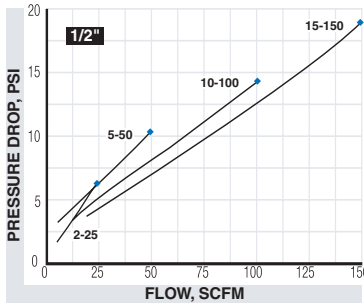
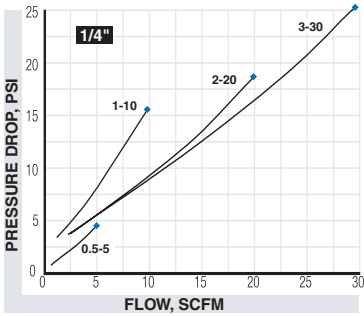

**NOTES:**

**NOTES:**



## WARRANTY/DISCLAIMER

OMEGA ENGINEERING, INC. warrants this unit to be free of defects in materials and workmanship for a period of **13 months** from date of purchase. OMEGA's Warranty adds an additional one (1) month grace period to the normal **one (1) year product warranty** to cover handling and shipping time. This ensures that OMEGA's customers receive maximum coverage on each product.

If the unit malfunctions, it must be returned to the factory for evaluation. OMEGA's Customer Service Department will issue an Authorized Return (AR) number immediately upon phone or written request. Upon examination by OMEGA, if the unit is found to be defective, it will be repaired or replaced at no charge. OMEGA's WARRANTY does not apply to defects resulting from any action of the purchaser, including but not limited to mishandling, improper interfacing, operation outside of design limits, improper repair, or unauthorized modification. This WARRANTY is VOID if the unit shows evidence of having been tampered with or shows evidence of having been damaged as a result of excessive corrosion; or current, heat, moisture or vibration; improper specification; mis-application; misuse or other operating conditions outside of OMEGA's control. Components in which wear is not warranted, include but are not limited to contact points, fuses, and triacs.

**OMEGA is pleased to offer suggestions on the use of its various products. However, OMEGA neither assumes responsibility for any omissions or errors nor assumes liability for any damages that result from the use of its products in accordance with information provided by OMEGA, either verbal or written. OMEGA warrants only that the parts manufactured by the company will be as specified and free of defects. OMEGA MAKES NO OTHER WARRANTIES OR REPRESENTATIONS OF ANY KIND WHATSOEVER, EXPRESSED OR IMPLIED, EXCEPT THAT OF TITLE, AND ALL IMPLIED WARRANTIES INCLUDING ANY WARRANTY OF MERCHANTABILITY AND FITNESS FOR A PARTICULAR PURPOSE ARE HEREBY DISCLAIMED. LIMITATION OF LIABILITY: The remedies of purchaser set forth herein are exclusive, and the total liability of OMEGA with respect to this order, whether based on contract, warranty, negligence, indemnification, strict liability or otherwise, shall not exceed the purchase price of the component upon which liability is based. In no event shall OMEGA be liable for consequential, incidental or special damages.**

CONDITIONS: Equipment sold by OMEGA is not intended to be used, nor shall it be used: (1) as a "Basic Component" under 10 CFR 21 (NRC), used in or with any nuclear installation or activity; or (2) in medical applications or used on humans. Should any Product(s) be used in or with any nuclear installation or activity, medical application, used on humans, or misused in any way, OMEGA assumes no responsibility as set forth in our basic WARRANTY/DISCLAIMER language, and, additionally, purchaser will indemnify OMEGA and hold OMEGA harmless from any liability or damage whatsoever arising out of the use of the Product(s) in such a manner.

## RETURN REQUESTS/INQUIRIES

Direct all warranty and repair requests/inquiries to the OMEGA Customer Service Department. BEFORE RETURNING ANY PRODUCT(S) TO OMEGA, PURCHASER MUST OBTAIN AN AUTHORIZED RETURN (AR) NUMBER FROM OMEGA'S CUSTOMER SERVICE DEPARTMENT (IN ORDER TO AVOID PROCESSING DELAYS). The assigned AR number should then be marked on the outside of the return package and on any correspondence. The purchaser is responsible for shipping charges, freight, insurance and proper packaging to prevent breakage in transit.

FOR **WARRANTY** RETURNS, please have the following information available BEFORE contacting OMEGA:

1. Purchase Order number under which the product was PURCHASED,
2. Model and serial number of the product under warranty, and
3. Repair instructions and/or specific problems relative to the product.

FOR **NON-WARRANTY** REPAIRS, consult OMEGA for current repair charges. Have the following information available BEFORE contacting OMEGA:

1. Purchase Order number to cover the COST of the repair,
2. Model and serial number of the product, and
3. Repair instructions and/or specific problems relative to the product.

OMEGA's policy is to make running changes, not model changes, whenever an improvement is possible. This affords our customers the latest in technology and engineering.

OMEGA is a registered trademark of OMEGA ENGINEERING, INC.

© Copyright 2005 OMEGA ENGINEERING, INC. All rights reserved. This document may not be copied, photocopied, reproduced, translated, or reduced to any electronic medium or machine-readable form, in whole or in part, without the prior written consent of OMEGA ENGINEERING, INC.

# Where Do I Find Everything I Need for Process Measurement and Control? **OMEGA...Of Course!** *Shop online at [omega.com](http://omega.com)*

## **TEMPERATURE**

- ☑ Thermocouple, RTD & Thermistor Probes, Connectors, Panels & Assemblies
- ☑ Wire: Thermocouple, RTD & Thermistor
- ☑ Calibrators & Ice Point References
- ☑ Recorders, Controllers & Process Monitors
- ☑ Infrared Pyrometers

## **PRESSURE, STRAIN AND FORCE**

- ☑ Transducers & Strain Gages
- ☑ Load Cells & Pressure Gages
- ☑ Displacement Transducers
- ☑ Instrumentation & Accessories

## **FLOW/LEVEL**

- ☑ Rotameters, Gas Mass Flowmeters & Flow Computers
- ☑ Air Velocity Indicators
- ☑ Turbine/Paddlewheel Systems
- ☑ Totalizers & Batch Controllers

## **pH/CONDUCTIVITY**

- ☑ pH Electrodes, Testers & Accessories
- ☑ Benchtop/Laboratory Meters
- ☑ Controllers, Calibrators, Simulators & Pumps
- ☑ Industrial pH & Conductivity Equipment

## **DATA ACQUISITION**

- ☑ Data Acquisition & Engineering Software
- ☑ Communications-Based Acquisition Systems
- ☑ Plug-in Cards for Apple, IBM & Compatibles
- ☑ Datalogging Systems
- ☑ Recorders, Printers & Plotters

## **HEATERS**

- ☑ Heating Cable
- ☑ Cartridge & Strip Heaters
- ☑ Immersion & Band Heaters
- ☑ Flexible Heaters
- ☑ Laboratory Heaters

## **ENVIRONMENTAL MONITORING AND CONTROL**

- ☑ Metering & Control Instrumentation
- ☑ Refractometers
- ☑ Pumps & Tubing
- ☑ Air, Soil & Water Monitors
- ☑ Industrial Water & Wastewater Treatment
- ☑ pH, Conductivity & Dissolved Oxygen Instruments