



Mobile

# IVG Installation and Troubleshooting Guide

80-JE026-1 B  
January 2016

Omnitracs, LLC  
717 N. Harwood Street, Suite 1300  
Dallas, TX 75201

Copyright © 2015-2016 Omnitracs, LLC. All rights reserved.

Omnitracs is a trademark of Omnitracs, LLC. All other trademarks are the property of their respective owners.

Omnitracs endeavors to ensure that the information in this document is correct and fairly stated, but Omnitracs is not liable for any errors or omissions. Published information may not be up to date, and it is important to confirm current status with Omnitracs.

This technical data may be subject to U.S. and international export, re-export or transfer (export) laws. Diversion contrary to U.S. and international law is strictly prohibited.

80-JE026-1 B  
January 2016

# ***Installation Contents***

---

1. Component Overview
2. Activation
3. Installation Planning
4. Display Interface Unit Installation
5. Power I/O Cable Connection
6. Optional Accessories
7. System Verification
8. Appendix Contents



# Important Safety Information

---

## Safety Definitions

The following Caution and Warning definitions are intended to advise the driver when it is safe to use a display unit.

**CAUTION** indicates a potentially hazardous situation which, if not avoided, may result in minor or moderate injury. It may also be used to alert against unsafe practices.

**WARNING** indicates a potentially hazardous situation which, if not avoided, could result in death or serious injury.

## Safety Advice

The following Safety Advice is provided for drivers, installers, and application developers who use and/or locate all types of display units.

**If you are a Driver**, do not use a display unit when the vehicle is in motion.

**If you are an Installer**, do not locate the display unit, including third-party devices, where it obstructs the driver's field of vision, distracts the driver from the driving task, or interferes with the driver's operation of controls or instruments. The following is displayed when ignition is turned on.



**If you are a Third-party Device Manufacturer or Application Developer**, it is your responsibility to provide appropriate warnings regarding the safe use of your device(s) in conjunction with Omnitracs equipment. Applications should not require the driver to divert his attention from the road while driving a vehicle.



**Components****IVG System**

- Color, graphical touchscreen display.
- Power I/O cable
- RMA Mount
- Holster
- Hardware



## IVG Display

- Color, graphical touchscreen display.
- Virtual on-screen keyboard
- 2 USB v2.0 ports on right side
- Micro SD slot on left side
- Home button - brightness and volume controls
- Volume control and brightness control buttons
- Diagnostic LEDs





**Power I/O Cable (9-pin "Y" cable with standard flanged end)**

Connects to a truck's 9-pin diagnostic connector for power and vehicle data on either J1587 or J1939 data links. This connector has a flange on the end where connected to the truck's dash.

- Part number 45-JC364-1A

**Power I/O Cable (9-pin "Y" cable with Paccar end)**

Connects to a truck's 9-pin diagnostic connector for power and vehicle data on either J1587 or J1939 data links. This connector is slightly larger than the flanged connector and has a nut that screws to the outside of the connector to mate it to the truck's dash.

- Part number 45-JC373-1A

**Power I/O Cable (6-pin "Y" cable)**

Connects to older model year trucks (1993 to 2003 models) that have a 6-pin diagnostic connector for power and vehicle data on J1708/J1587 data link.

- Part number 45-JC365-1A



## Volvo/Mack J1587/J1708 and J1939

Volvo trucks 2014 or newer with Volvo engines and Mack trucks 2014 or newer with Mack engines will use a diagnostic connector that resembles a standard automotive OBDII connector. This connector provides power and vehicle data for J1939/J1708 (does not use the OBDII protocol).

- Part number 45-JC366-1A



## Hino

For late model 2011 and 2012 or newer Hino trucks, you can connect directly to the Hino Telematics connector. The blue connector is for Japanese manufactured trucks and the white connector is for U.S. manufactured trucks.

- Part number 45-JC375-1A

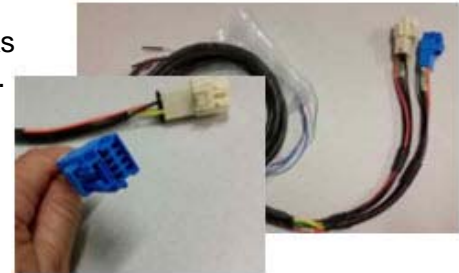

## Power I/O Cable (9-pin "Y" cable 500k - green connectors)

For newer trucks with 500K green diagnostic connectors. Connects to a truck's 9-pin diagnostic connector for power and J1939 500K vehicle data. This connector has a flange on the end where connected to the truck's dash.

- Part number 45-JE006-1A



## **Display Holster**

Allows the display to be moved around the cab, or secured on the dash while the truck is operating.

- Part number CV90-JC339-710



## **RAM Mount**

Used for mounting the display/holster to the dash.

- Part number 65-JB313-1



## **Backing Plate**

Always use the supplied backing plate to strengthen the support for the mount.

- Part number 50-JB290-1



## **Product Documentation**

You should have also received the following product documentation. Ensure you leave all documents in the cab of the vehicle.

- IVG Getting Started Guide (80-JE014-1)
- HOS DOT Quick Reference Card for IVG (80-JE015-1)
- HOS MOT Quick Reference Card for IVG (80-JE016-1)



## Activation

### Online Activation

Online activation process should have already been completed at least one day prior to installation. This assigns the unit to the correct customer account and registers it on the cellular network.

IVG activation requires access to the Customer Portal. Contractors and Service Centers must work with the customers to activate units.

The online activation process may take up to two hours to complete. To perform the online activation:

1. Using your supplied credentials, log into: <https://customer.myqualcomm.com>.
2. Click on the **Activations** icon on the home page.

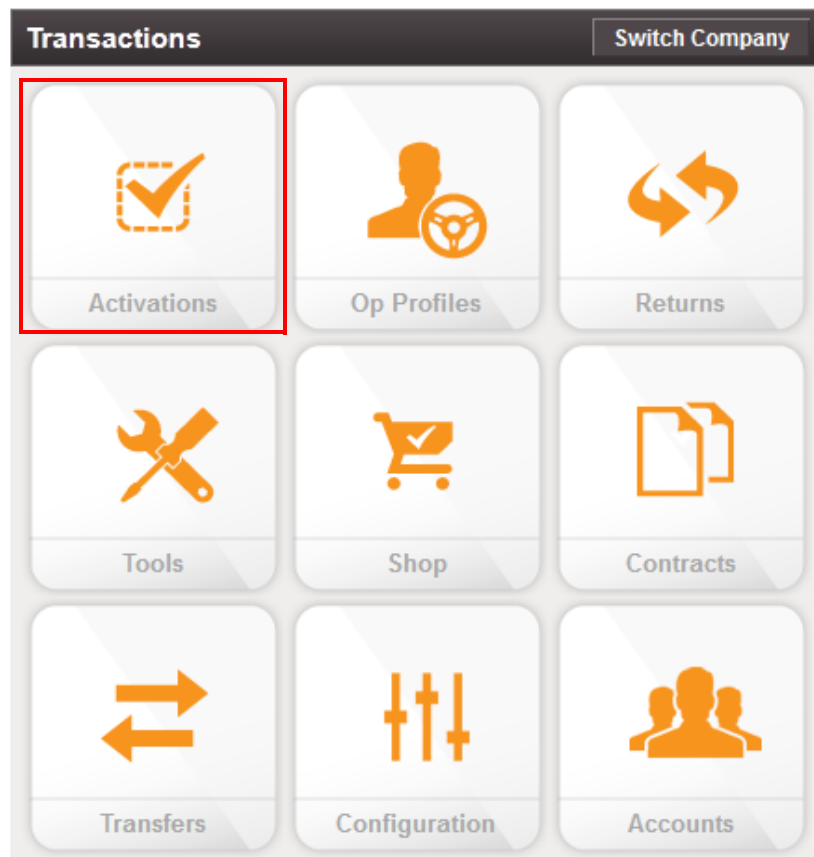

You will then see the main Activations screen. From here click **Continue** under **System Activation**.

### Activate IVG Units









**IMPORTANT**

- Activate your new or replacement units prior to installation.
- Activate only those units you intend to install.

There is a new process to activate your units. See the video here

 You have units that are not active. Activate them 2 hours before installation.

### Activation Selection

 <b>System Activation</b>	 <b>Search Unit Activation</b>
	Search by serial number to see activation status
<b>Continue</b> 	<b>Continue</b> 
 <b>Activation History</b>	
Activation Request History	
<b>Continue</b> 	

3. To verify that the unit you are installing is activated, click **Activation History**. Choose what types of activations you want to see. You will then see a screen similar to the following.

**Note:** You can only search previous replacements.

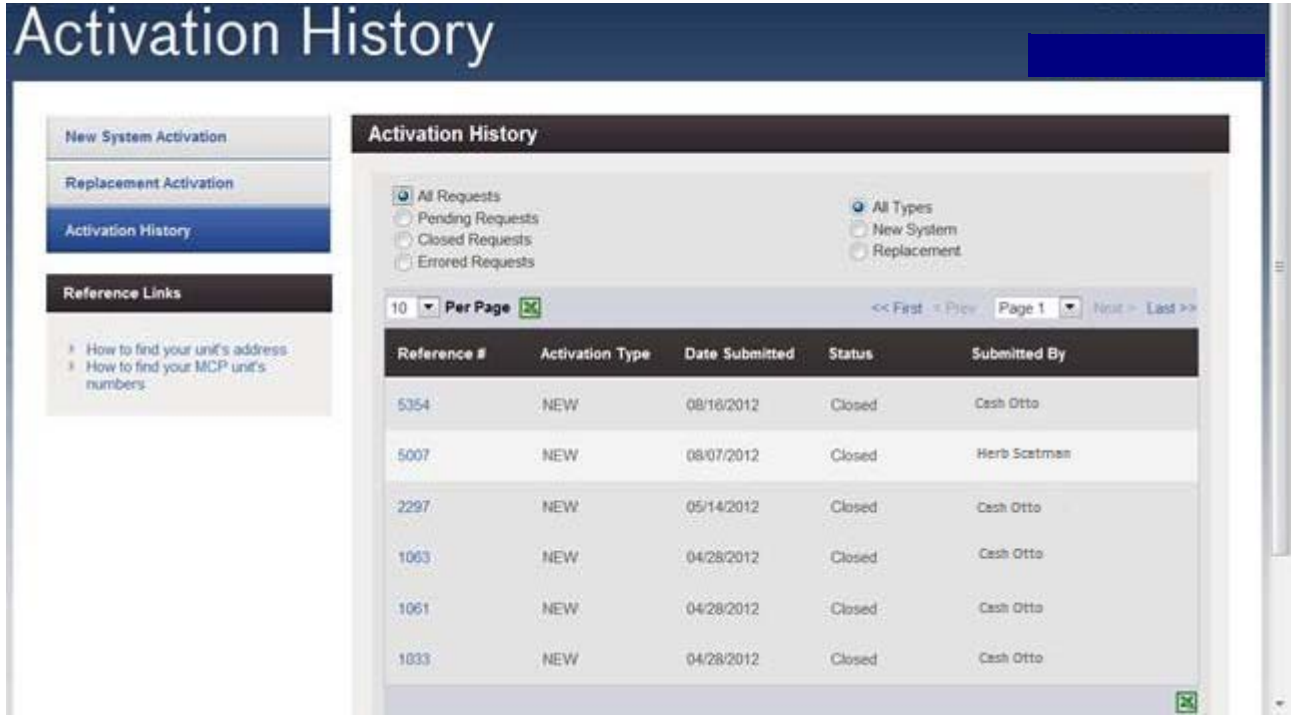

### Application Management

The applications that are made available to a unit are assigned by the customer using an operational profile. A customer can select which applications a given unit should have. Those applications that are not available will not be selectable at the IVG display (grayed out).

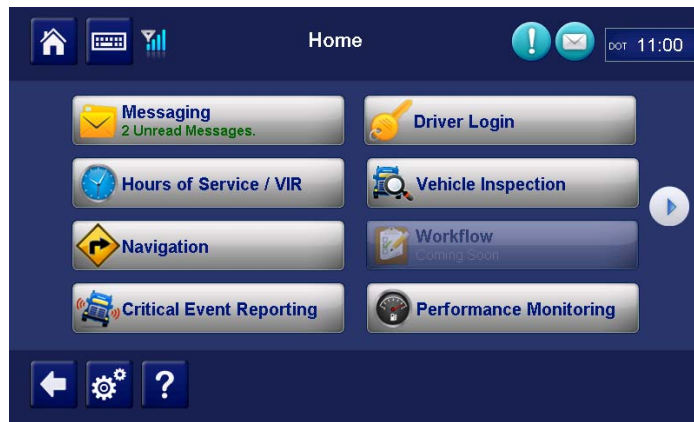

1. To make changes to operational profile, from the Customer Portal home page, click the **Operational Profiles** icon.

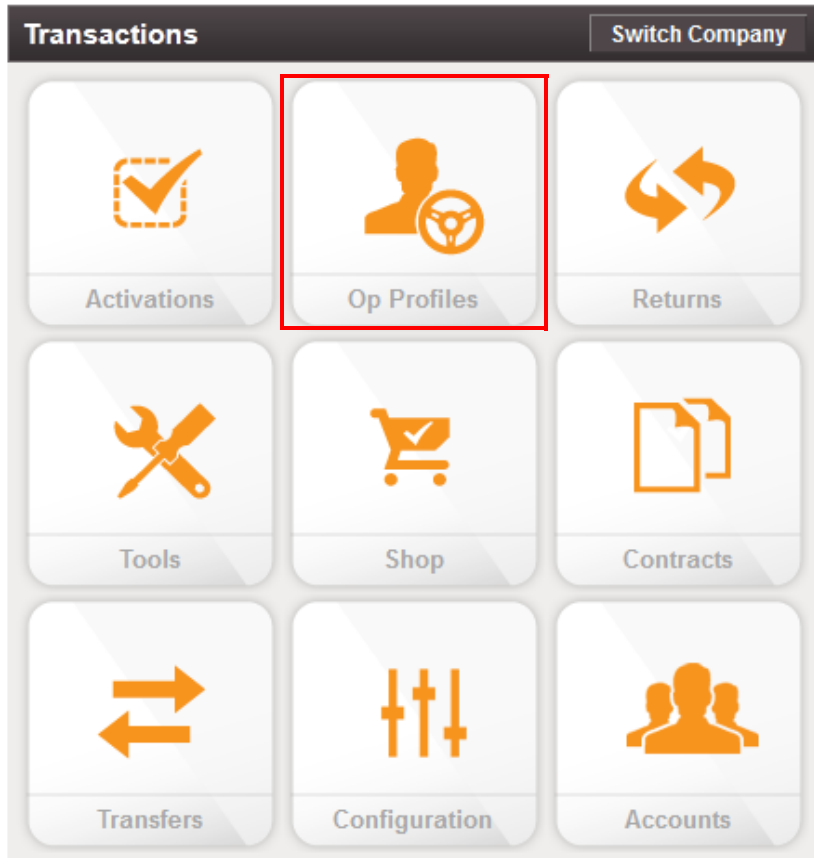







2. Click **Manage Operational Profiles**.

### Operational Profiles



Operational Profiles are used to group trucks or vehicles by a set of active applications. You will see an initial Operational Profile for active units and another one for inactive units. You will need to create additional profiles as necessary.

### Please Make a Selection

 <b>Manage Operational Profiles</b> Click to view current profiles <b>Continue</b> >	 <b>Create New Profile</b> Click to create a new or copy an existing profile. <b>Continue</b> >
 <b>Move Units</b> Click to move units between profiles. <b>Continue</b> >	 <b>Locate a Unit</b> Click to find the profile a unit is in. <b>Continue</b> >
 <b>Deleted Profiles</b> Click to view previously deleted profiles <b>Continue</b> >	

3. A screen similar to the below will list the available operational profiles.

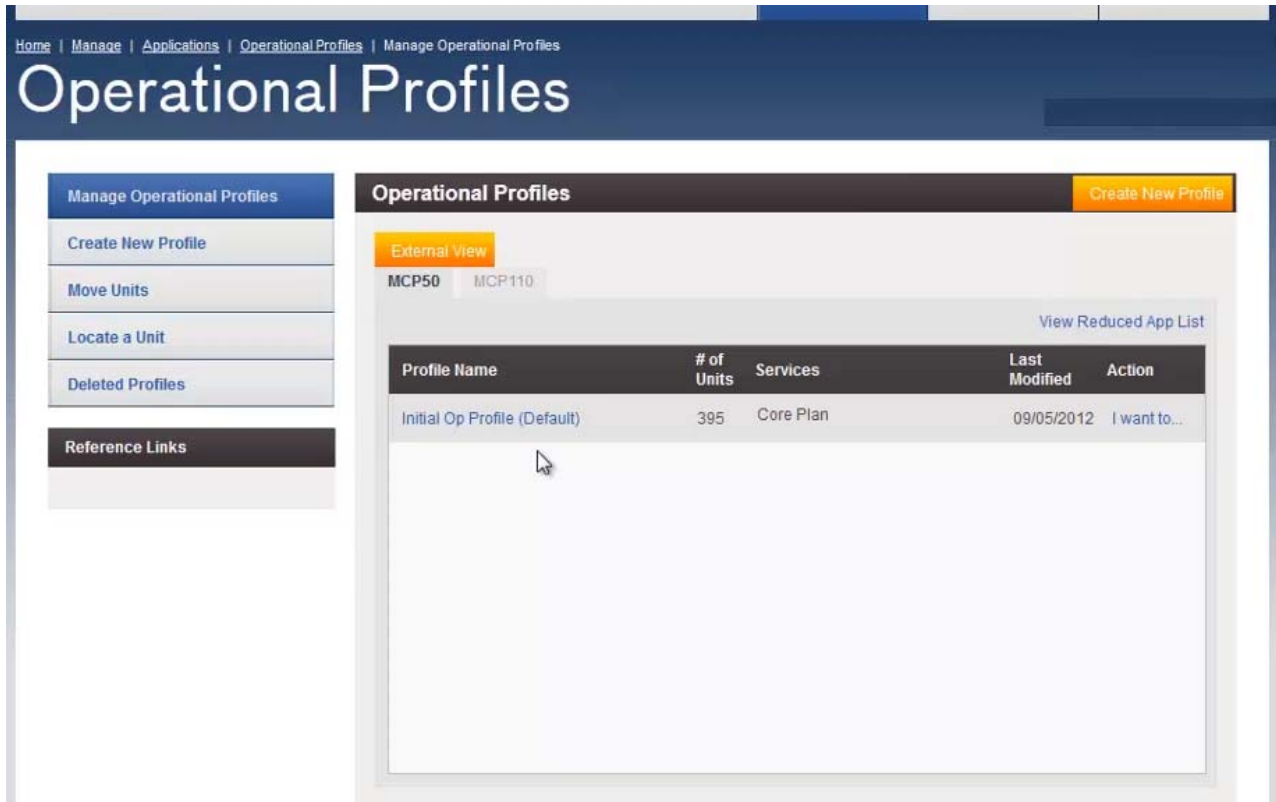

## **Regulatory Compliance Information**

### **FCC/IC Compliance Statement**

This device complies with part 15 of the FCC Rules. Operation is subject to the following two conditions:

- (1) This device may not cause harmful interference, and
- (2) this device must accept any interference received, including interference that may cause undesired operation.

#### **Note**

*This equipment has been tested and found to comply with the limits for a Class A digital device, pursuant to part 15 of the FCC Rules. These limits are designed to provide reasonable protection against harmful interference when the equipment is operated in a commercial environment. This equipment generates, uses, and can radiate radio frequency energy and, if not installed and used in accordance with the instruction manual, may cause harmful interference to radio communications. Operation of this equipment in a residential area may cause harmful interference in which case the user will be required to correct the interference at his own expense.*

---

#### **Caution**

*Any changes or modifications not expressly approved by the party responsible for compliance to this equipment would void the user's authority to operate this device.*

---

This device complies with Industry Canada's license-exempt RSSs. Operation is subject to the following two conditions:

- (1) This device may not cause interference; and
- (2) This device must accept any interference, including interference that may cause undesired operation of the device.

*Le présent appareil est conforme aux CNR d'Industrie Canada applicables aux appareils radio exempts de licence. L'exploitation est autorisée aux deux conditions suivantes :*

- 1) l'appareil ne doit pas produire de brouillage;*
- 2) l'utilisateur de l'appareil doit accepter tout brouillage radioélectrique subi, même si le brouillage est susceptible d'en compromettre le fonctionnement.*

CAN ICES-3 (A)/NMB-3(A)

### **RF Exposure Information (SAR)**

Refer to Appendix I, [RF Exposure Information \(SAR\)](#)

## **Installation Guidelines**

### **Typical Installation Steps**

1. Online Activation (at least one day prior)
2. Display Installation
3. Power/IO and ignition connection
4. System verification

### **Safety, Reliability, and Accessibility**

- Use eye protection when using a drill/performing work that may be hazardous to the eyes.
- Use ear protection in noisy work areas.
- Wear appropriate clothing/uniforms and safety shoes.
- Maintain three points of contact when climbing in and out of cab.
- Make sure you know what is behind the area before you drill.
- Install equipment so it will not cause damage to the vehicle or work loose over time.
- Make sure there are no loose components/cables and no unsecured components.
- Use solid mounting surfaces.
- Route all cables away from hot or abrasive areas.
- Choose installation locations where components can be easily serviced.
- Choose installation locations where components are safe from tampering and damage.

### **Tools and Supplies Recommended for Installation**

- Crimpers
- Diagonal Wire Cutters
- Wire Strippers
- Screwdrivers: Phillips #2 and Slotted
- Torx Drivers: #20 and #25
- Volt/ohm Meter
- Flush Cutters
- Flash/Drop Light

### Selecting a Mounting Location



### IMPORTANT SAFETY INFORMATION

---



#### **WARNING**

*Do not locate the display unit where it obstructs the driver's field of vision, distracts the driver from the driving task, interferes with the driver's operation of controls or displays, or creates a safety hazard. Follow all laws and regulations governing the placement of equipment and mounts.*

---

#### **DO locate the Display where:**

- it can be safely installed on a secured bracket that is robust enough to minimize any vibration and sustain the weight of the Display.
- the mounting surface is strong enough to support the mounting hardware.
- the mounting surface is flat.
- it is in the driver's line-of-sight, easy to touch, but does not block the view of the road or mirrors.
- the surrounding area is clear of dash controls and gauges.
- it is not mounted in constant, direct sunlight.
- it does not limit a passenger's leg room or block access to any other compartments.
- it does not interfere with anyone entering or exiting the vehicle cab.
- it is not likely to impact the driver or passenger in case of an accident or collision.

**DO NOT locate the display where it:**

- obstructs the driver's field of vision.
- distracts the driver from the driving task.
- interferes with the driver's operation of controls or shifting.
- obstructs the area swept by the windshield wipers.
- blocks the deployment of an airbag.

**Additional information for selecting an installation location:**

- Installations should not obstruct the driver's field of vision while operating the vehicle, and should comply with all applicable federal and state laws and regulations regarding appropriate installation locations (including restrictions against the mounting of objects on a vehicle's windshield) and driver distraction.
- Consider the owner's preference in selecting the installation location and whether there is a team or a single driver.



***Installing the Display***

Included with the IVG system is RAM mounting hardware. Always use the supplied backing plate to strengthen the support for the mount.

1. After a suitable location is selected, verify that there is nothing behind the mounting surface that might be damaged by drilling holes.

2. Drill 3/16" holes for the mounting bracket and backing plate using the backing plate as a template.



3. Attach the RAM mount ball joint to the dash using the supplied 8x32 screws, lock washers, and backing plate. This hardware is included with the RAM mount kit.
4. Attach the other RAM mount ball-joint to the holster using supplied screws and lock washers. The supplied screws are 1/2" long. DO NOT use screws that are too long or they will protrude through the holster.

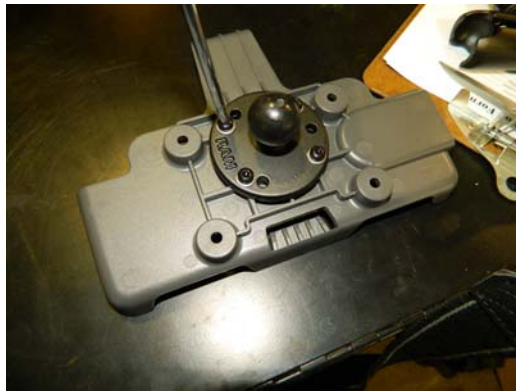

5. Join the holster-side ball joint to the dash-side ball joint using the RAM mount arm. Loosen the arm lever and adjust the holster to the desired position and then tighten the arm lever to secure assembly into place. Be sure the arm is loosened prior to making adjustments and then retightened to secure in place.



6. Snap the display into the holster by placing the bottom into the lower holster tabs and then push the top into the upper holster tab. It will snap into place.
7. Allow just enough display cable slack so the DIU can reach the driver steering wheel only. Ensure any excess cable is secured and does not interfere with the operation of the vehicle. Cable should not drape on the floor or cause a tripping hazard.
8. Add a tiwrap strain relief to the DIU cable where it comes out from under or behind the dash so it can't be pulled out further.

---

**WARNING**

*Excess cable can be a tripping hazard. Ensure cable is not draped where it will interfere with either the driver or passenger as they move within the cab.*

---



## Power I/O Cable Connection



The power I/O cable is used to connect to a truck's Diagnostic Connector. It provides both power and the necessary vehicle data for the IVG system. There are multiple masterpacks depending on the truck type. See the individual Truck Installation Suggestion documents for more information. See [Appendix G: Component Information](#) for more information

Cable	Trucks
9-pin	Most 2006 and newer trucks
6-pin	Most 2005 and older trucks
9-pin adapter	Late model Kenworth and Peterbilt trucks
OBDII style	2014 and newer Volvo/Mack trucks

9-pin 500 Kbps	2016 and newer model trucks with green diagnostic connectors
Hino	Late 2011 and newer Hino trucks

The appropriate IVG kit/masterpack should have been ordered for your installation. If the power I/O Cable connector does not mate to the truck's diagnostic connector, the Y portion of the power I/O Cable will need to be cut off and wires will need to be crimp spliced. See [Chapter C: General Wiring and Installation Guidelines](#) for instructions.

## Connecting the Power I/O Cable

1. With the truck's ignition OFF, remove and push back existing truck diagnostic connector. Check connector to verify it's clean of debris and there are no bent pins.
2. Connect the power I/O cable connector to the truck's diagnostic connector. Verify the outer ring is twisted and clicks into place so the ends do not become unconnected by accident. Verify by pull testing the connector.



3. Put the unused power I/O cable end where the truck's diagnostic connector was located.
4. Route power cable to the IVG display location..
5. Remove torx10 screws from door panel on back side of IVG display and connect power cable to the IVG display. Ensure it latches solidly.



6. Replace door panel and secure any excess cable using tie-wraps.

**Optional connections:**

- PTO (Power Take-off)
- Trailer Tracks
- Panic Button

**PTO (Power Take-off) Overview—Optional Connection**

This option provides the ability to log the time the vehicle engine is used for operational idle purposes, such as when it is powering auxiliary devices using a pump or compressor.

In order to log PTO time, the installation involves connecting one of the two PTO wires.



The loose white/black wire labeled PTO/DIGIN\_1, in the power I/O cable is the PTO wire.

The IVG system detects an active PTO device when it sees 12 volts (active high) on this PTO/DIGIN\_1 wire. A PTO switch that goes active to ground will require a relay for the 12 volt detection.

**PTO Installation**

Use a multi-meter to determine which type of PTO circuit you are connecting to when engaging the PTO switch.

**Wiring to Switched +12VDC Circuit**

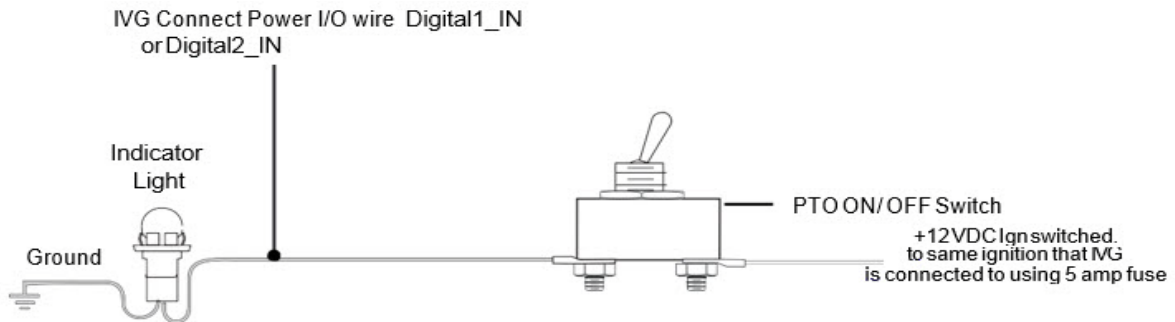

D4AAA\_217AQMCP

**Wiring to Switched Ground Circuit**

If you have a switched circuit that is activated to the ground to detect PTO time, a relay must be used.

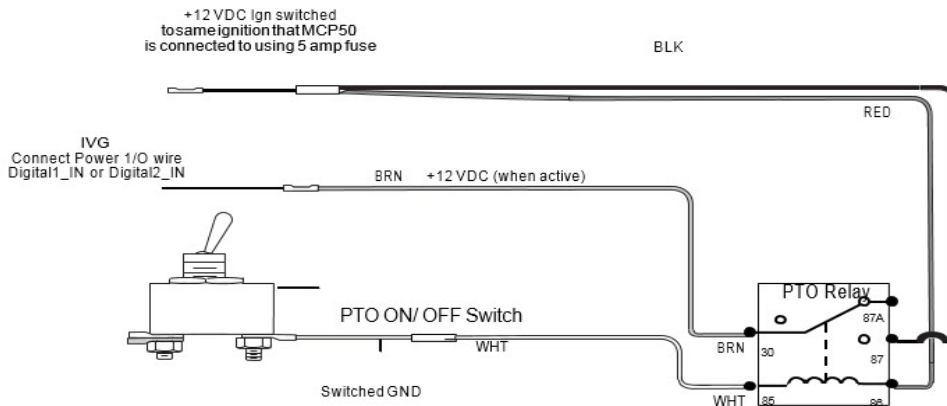

**Wiring to an Air Pressure Switch for Air-activated PTO**

If the air pressure switch is not wired to 12 VDC, make sure to remove the ground wire and attach a fused wire from the IVG ignition source.

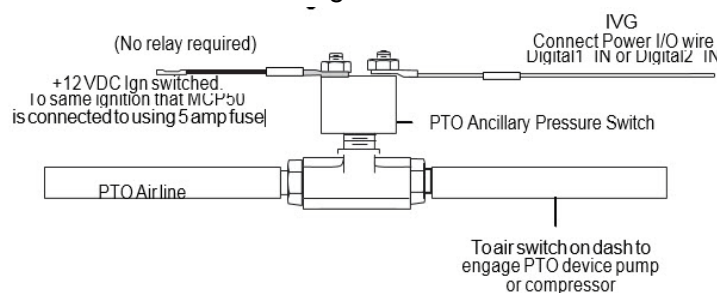

### PTO Data Input Verification Procedure

1. Start the vehicle.
2. Turn the PTO switch **ON**.
3. Navigate to the **System VDS** screen.
4. Tap the green up and down arrow button at bottom of the screen (circled below).

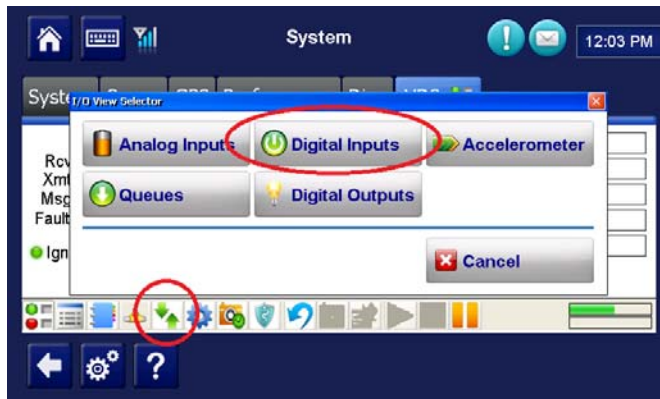

5. Verify the PTOC has a green dot under the Index column and shows "On" under the **State** column.

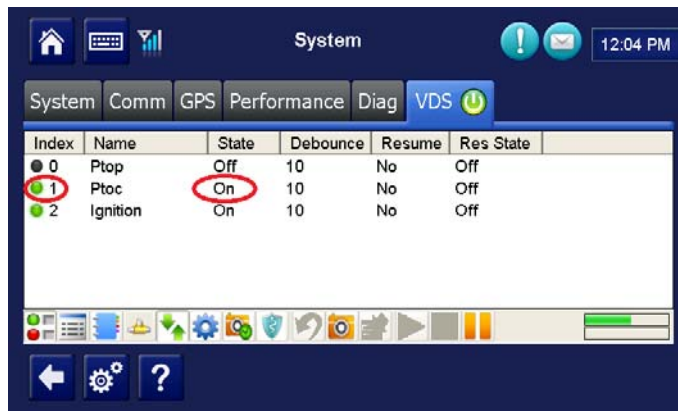

**NOTE:**

PTOC: PTO/DIGIN\_1 in wire in the wire harness  
 If PTOC is not showing a green dot or "On," check the PTO wire connections.

6. Turn off PTO device. The green dot and state will change (i.e., to a black dot and "Off").
7. At this point, the PTO wire installation verification is complete.
8. Verify through the Performance Monitoring screens that the PTO application is recording correctly.

9. Start the vehicle.
10. Turn the PTO device to ON.
11. Navigate to the PTO screen. Tap the **Performance Monitoring** button, then tap the **PTO** tab.

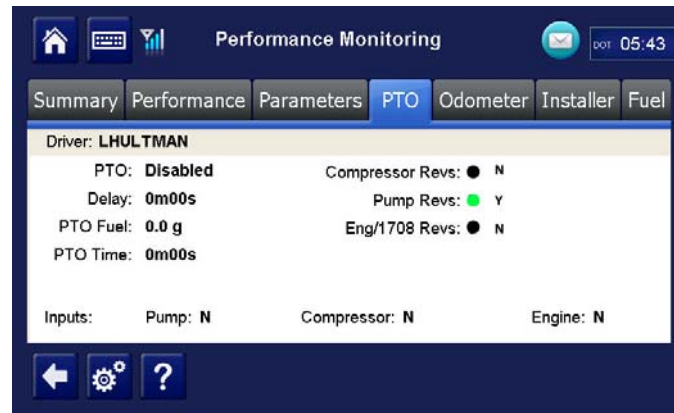

**Note:** If the Performance Monitoring button is grayed out, Performance Monitoring is not enabled. Call your company dispatch to have this application enabled. Performance Monitoring parameters must be sent to the unit as well.

12. Verify that PTO is Enabled and the Compressor or Pump displays a **Y** according to what is active.
13. You should see the green indicator light according to what is active.
14. Check that the **PTO Time** field is incrementing. Is this field incrementing?

**Note:** In order for PTO time to be recorded in Performance Monitoring, RPM must be >0, speed <20 mph, and the PTO time delay (customer configured) must be reached.

- If yes, PTO verification is complete.
  - If no, check the wire connections.
15. Turn off PTO device. PTO time should now stop incrementing.

## Trailer Tracks Installation (placeholder)

## Trailer Tracks Verification (placeholder)

## Panic Button Installation (placeholder)

***Panic Button Verification (placeholder)***





### Performing System Verification

Shortly after you power up the IVG, the Driver Warning screen appears. After tapping the **OK** button, the IVG Home screen displays.

1. Tap the arrow on the right until you see the System button, then tap the **System** button.



2. Tap the **Diag** tab. **Note:** the IVG Unit Address (UA) shows at the top.

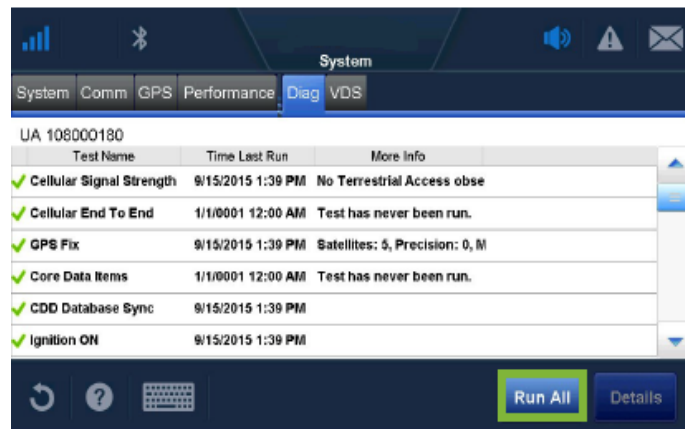

3. Tap the **Run All** button, located at the bottom right of the screen. The system runs tests on all listed items then displays the results.

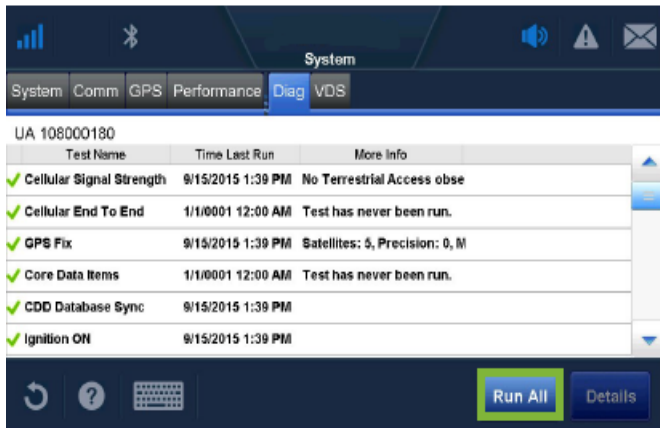

First page of tests

If the test passes, a (green ✓) is shown. If the test fails, a (red X) is shown.

**Note: Green checkmarks next to Cellular Signal Strength, Cellular End to End, GPS, and Core Data Items are required for the IVG system to be ready for use.**

<b>Item</b>	<b>Description</b>
<b>Cellular Signal Strength</b>	Will show a green checkmark when in good cellular network coverage. See <a href="#">Chapter 13: Cellular Signal Strength Problems</a> if red X.
<b>Cellular End To End</b>	Will show a green checkmark if the unit is successfully transmitting with Omnitrac and received an acknowledgement back. See <a href="#">Chapter 12: Cellular End to End Problems</a> if red X.
<b>GPS fix test</b>	Will show a green checkmark if GPS network is detected and it is getting a 3D fix. See <a href="#">Chapter 15: GPS Fix Problem</a> if red X.
<b>Core Data Items</b>	Will show a green checkmark if Speed, RPM, Distance LTD, and Fuel LTD is being detected. See <a href="#">Chapter 19: Core Data Problem</a> if red X.
<b>CDD Database Sync</b>	Will show a green checkmark when database has been synchronized with NOC (usually take 5 to 10 minutes after unit is first powered up. See <a href="#">Chapter 14: CDD Database Sync Problem</a> if red X.
<b>Ignition On</b>	Will show a green checkmark if the ignition is ON. See <a href="#">Chapter 18: Ignition On Detection Problem</a> if red X.

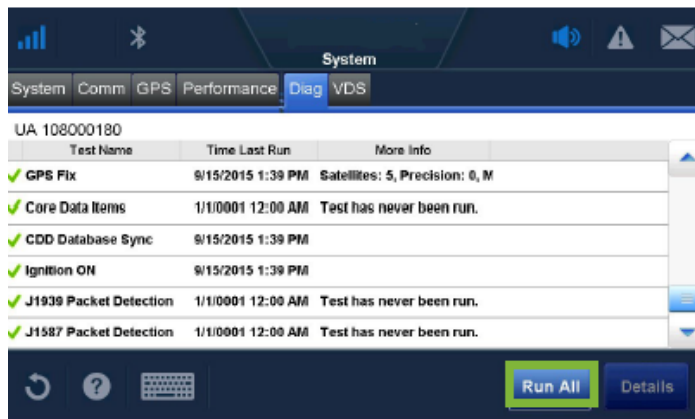

Second page of tests

Use scroll bar to see all results.

CDD and Ignition On should have a green checkmark.

### J1939 Packet Detection

Will show a green checkmark if connected to the J1939 databus, while the vehicle's running and when the truck is providing J1939 data. Some vehicles do not have the J1939 bus. See [Chapter 17: J1939 Packet Detection Problem](#) if red X.

### J1587 Packet Detection

Will show a green checkmark if connected to the J1587 databus, while the vehicle's running and when the truck is providing J1587 data. Some vehicles do not have the J1587 bus. See [Chapter 16: J1587 Packet Detection Problem](#) if red X.

For information on the **Details** button, see [Chapter 19: Core Data Problem](#).

If the results of the **Run All** tests are acceptable, send a message from the unit and verify the message is received by dispatch. Once that is confirmed, have dispatch send a message and confirm the message is received. If installation is done after hours, call Customer Support to verify the message is sent and received. **Once this is done, System Verification is complete.**



# ***Troubleshooting Contents***

---

- 8. Troubleshooting Best Practices
- 9. Display Screen is Dark or Blank
- 10. Display Problems
- 11. Cannot Send Messages
- 12. Cellular End to End Problems
- 13. Cellular Signal Strength Problems
- 14. CDD Database Sync Problem
- 15. GPS Fix Problem
- 16. J1587 Packet Detection Problem
- 17. J1939 Packet Detection Problem
- 18. Ignition On Detection Problem
- 19. Core Data Problem
- 20. IVG DIU LED Indicator
- 21. IVG Display Icons and Indicators
- 22. Performance Monitoring Troubleshooting
- 23. Critical Event Reporting Troubleshooting
- 24. Optional Accessories Troubleshooting



## ***Troubleshooting Guidelines***

### ***Keep Known Good IVG Component Spares in Shop***

Spare parts should include:

- IVG system
- IVG power I/O cable

### ***Use a Test Cart to Perform Bad Part Verification/Double Checking***

If an Omnitracs IVG part is diagnosed bad on a truck, insert the failed part on the test cart or another truck that is known to be good (diagnostic connector).

- If part continues to fail, part should be RMAd or replaced in the event it's the power I/O cable.
- If the suspect part does not fail on the test cart, further troubleshooting will be necessary.

### ***Perform a Visual Inspection of the Installed IVG***

- Check for damaged cables, improper electrical connections, loose connections, and the integrity of the installation.
- Bad mounts can contribute to system problems.
- Loose connections or parts not installed properly can allow excessive vibration which can affect system performance.

### ***Reseat Cable***

- Always inspect and reseat the cable connector prior to replacing the IVG display.
- Inspect for corrosion and bent, broken, pushed, missing pins, and/or sockets.

### ***Verify IVG Display LED Indicator are in a Normal State***

- When booting up, several of the LEDs will blink.
- Once boot up is completed, the top LED will blink blue every 1-2 seconds when operating normally. The middle LED will blink green every 3-4 seconds.

### ***Check System Voltage Measurements and Grounding***

- Use the same ground reference that the particular circuit uses.
- Verify that vehicle battery and cables are in good condition.
- Check voltages (see [Appendix A](#) for more information):

### ***Replace Only Faulty Parts***

Typically, only one part is bad. Once the system is operating, you can substitute suspect parts back into the system to verify which part is bad, or use a test cart equipped with known good spare parts to retest suspect parts.

### ***Determine If the Problem Is Intermittent***

Check for bad or loose electrical connections including cable connectors, ring terminals, butt splices, and power/ground connections. These can contribute to intermittent system performance.



## Display Screen is Dark or Blank

---

### **Problem: Display Screen is Dark or Blank**

If the display is blank or dark it could be:

- Unit is asleep (i.e. ignition detected as OFF and power down timer exceeded)
- Power source or power I/O cable problem
- Ignition detection not working
- Faulty IVG Display

Start the vehicle engine.

- Check to see if the LEDs on the display are blinking blue (top LED) and green (middle LED).



- If the LEDs are not blinking, use a digital volt meter to check for power at the truck's diagnostic connector. Pin-outs for the 6-pin and 9-pin connectors are in the [Appendix A: Wiring Diagrams and Charts](#)

### **Problem: Display Immediately goes Blank when Ignition is Turned Off**

When vehicle ignition is turned OFF, the display should stay on for the period of time that has been configured by dispatch. This is the power down time. If the display screen immediately blanks out when the ignition is turned OFF, this could be caused by:

- The IVG' power-down time or total time is set to zero.
  - Check the host software configuration.

**Note:** The power-down time should not be set below five minutes.

- Make sure primary power is constant not switched.

Verify diagnostic connector power is ON with ignition On or Off. It cannot be switched.

*Problem: Display Immediately goes Blank when Ignition is Turned Off      Display Screen is Dark or Blank*

See, [Appendix A: Wiring Diagrams and Charts](#), for wire diagrams and schematics of the different diagnostic connectors.

### IVG Display Overview

- The DIU is a color, graphic touchscreen display. When the vehicle's engine is running, the display screen should be powered and on. It says on until the ignition is turned off and the IVG power-down timer expires - it then goes dark. The power-down timer is configured by the customer's dispatch system.
- When the vehicle is running, an image appears on the display screen. To adjust the brightness, use the brightness buttons located to the left of the **Home** button. Press the + (plus) button to increase brightness or - (minus) button to decrease brightness.



- When the brightness buttons are pressed, a pop-up window will appear on the screen indicating the current brightness level.
- Text-to-speech is played through the display's two speakers. To adjust the volume, press the volume buttons located to the right of the **Home** button. Tap the + (plus) or - (minus) buttons to adjust. When the volume controls are used, a pop-up window will appear on the screen indicated the current volume level.



**Problem: Touchscreen Non-responsive/Calibration**

If you are tapping anywhere on the touchscreen and the screen is not responding quickly or the screen arrow is not where the screen was touched, the touchscreen may not be calibrated properly. To recalibrate the DIU touchscreen settings, from the Home screen:

1. Tap the **Settings** button then tap the **Calibration** tab.
2. Tap the **Calibrate** button.
3. When the targets display, carefully tap and hold down each of the **targets (+)** in the center and release when instructed. It is best to use your finger to calibrate.
4. When the last target is touched, the calibration is complete.
5. If the touchscreen does not allow you to get to the calibration screen, a USB mouse can be connected to use as a pointer. After you get to the targets, use your finger to tap the screen.

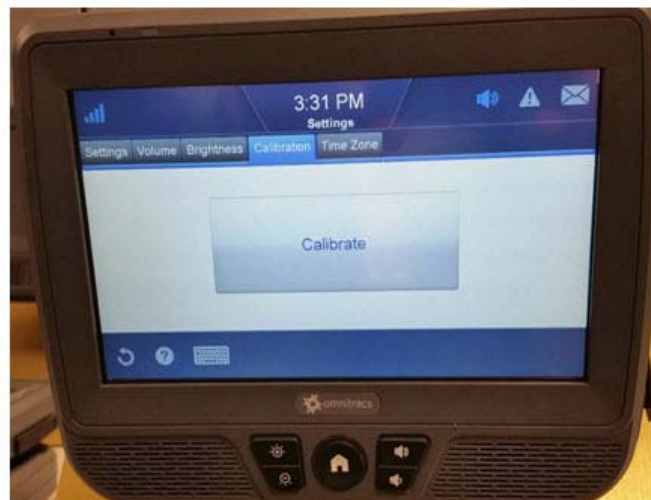
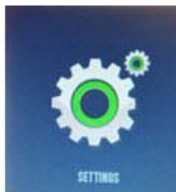

6. If the touchscreen/display is still unresponsive, use the reset button on the left side of the display to reboot the unit. It will take the system several minutes to reboot.

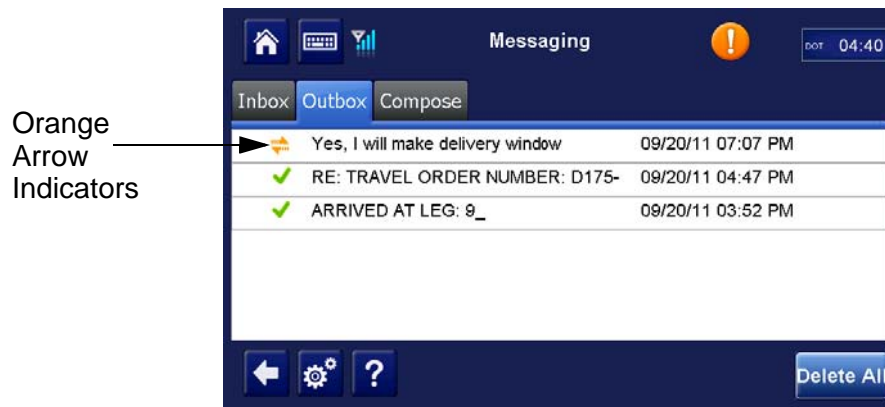
**Problem: Cannot Send Messages**

If a message has been queued and shows up in the Messaging Outbox with orange arrow indicators for more than a minute, do the following:

1. Verify the Cellular End To End test under the System Diag Run All test passes. See [Chapter 12: Cellular End to End Problems](#).
2. Verify the Cellular Signal Strength indicator shows the unit has acceptable signal. See [Chapter 13: Cellular Signal Strength Problems](#).
3. If both the Cellular End To End and Cellular Signal Strength are good:  
  
Reboot the unit by pressing the reset button on the left side of the display. Give the unit time to boot up and reacquire cellular signal before checking the message status indicators.
4. If problem still persists, Call Omnitracs Customer Support at 800-541-7490 for assistance.



### Problem: Cellular End to End Test Fails

If the Cellular End to End test is failing when performing a system verification, the likely cause is the system has not been properly activated.

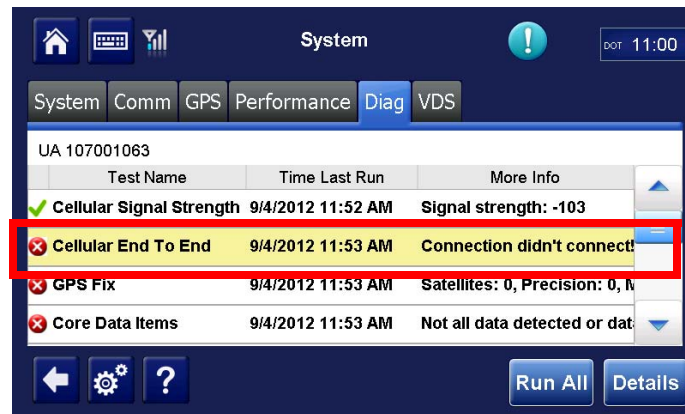

To see the details of this information:

1. Highlight the **Cellular End To End** Line.
2. Tap the **Details** button. A lot of information is provided at the bottom of the screen.

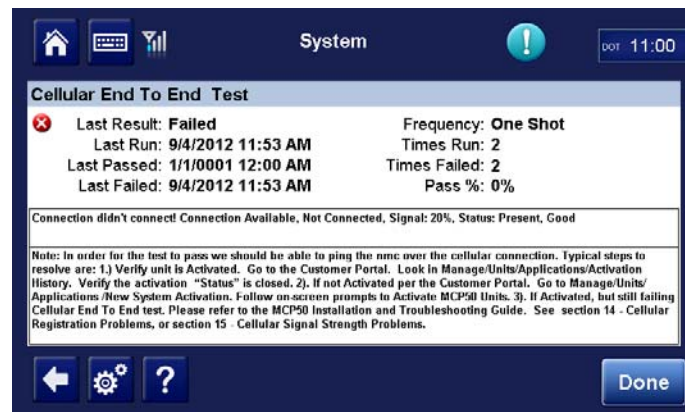

3. Tap the **Done** button.





## Cellular Signal Strength Problems

### Problem: Cellular Signal Strength Fails

If the Cellular Signal Strength test is failing when performing a system verification, or the cellular icon at the top of the screen shows a red X and no colored bars, follow the steps below.

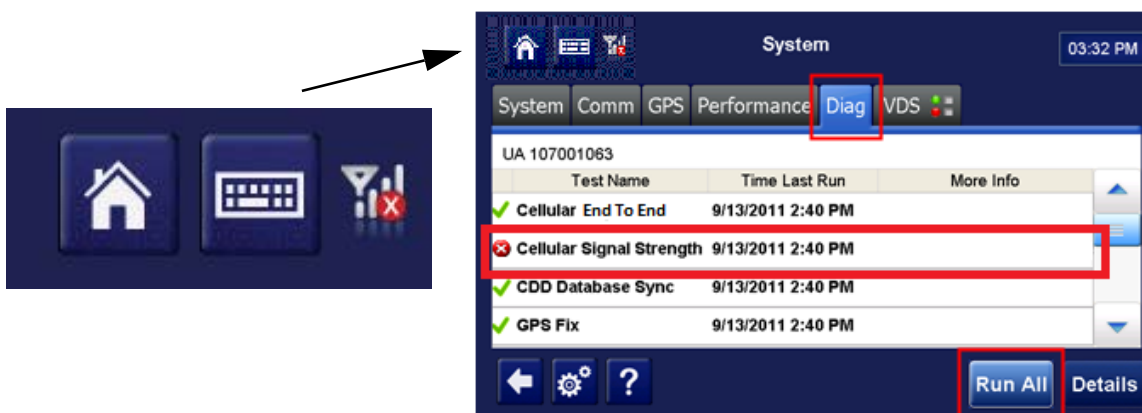

For detailed information concerning Cellular Signal Strength, tap the **System** button, then tap the **Comm** tab.

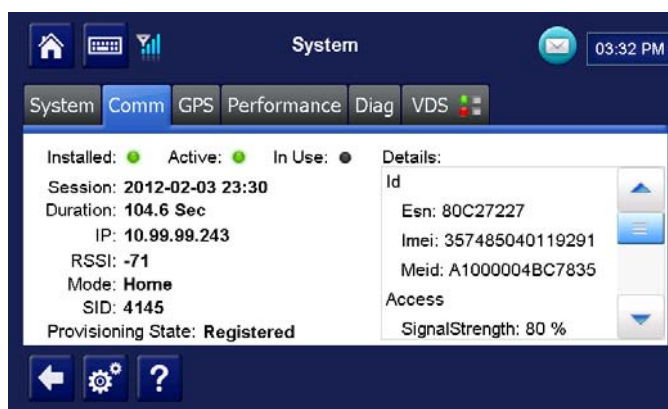

RSSI to number of bars:

-50 to -75	four bars
-76 to -85	three bars
-86 to -95	two bars
-96 to -105	one bar
-106 to -109	no bars
-110 to -200	no signal light will come on

1. Verify that the truck is at a location where there is known to be good cellular coverage.
2. Check to ensure there are no metal obstructions above the IVG display.
3. If there are no obstructions, inspect the antenna and antenna cable to ensure there is no damage.
4. If there is still a problem, test with known good antenna.

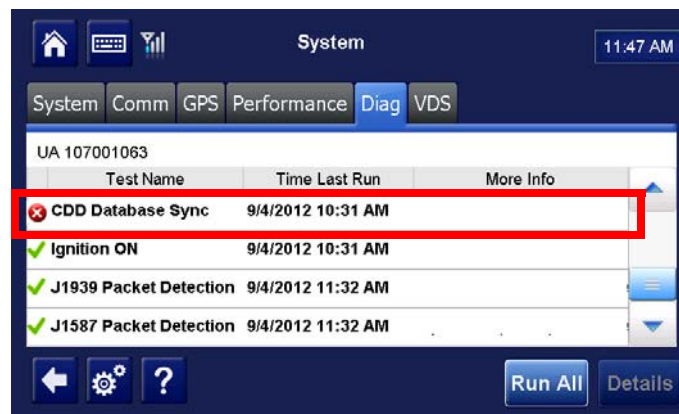
**Problem: CDD Database Sync Test Fails**

After an IVG is installed and powered up with good signal and line-of-sight to the GPS satellites, it usually takes about 10 minutes for it to get all the company-defined settings and configurations. After it acquires all settings and configurations, it will go into the desired state of Sync complete. If an IVG is installed and powered up and has not gone to a database state of Sync Complete within 10 minutes:

1. Verify that the unit has been properly activated. Make sure that the Cellular End To End passed. See [Chapter 2: Activation](#).
2. Check that the unit has cellular signal and is able to connect. See [Chapter 13: Cellular Signal Strength Problems](#).
3. If it is activated/registered and able to connect, but will not go to a Sync complete state, call Omnitrac's Customer Support at 800-541-7490 for assistance. Ask for Out of Sync command.
4. If the problem still persists, Replace/RMA the IVG unit.



### Problem: GPS Fix Test Fails

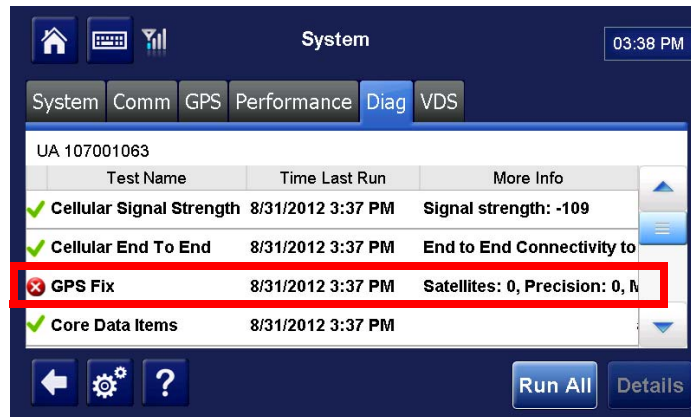

For more detailed information concerning GPS status, use the **GPS** tab (screen below).

Normally the GPS positioning system will update positioning data every second at the IVG, as shown in the Last Update field of the **System>GPS** tab. The desired value for the Mode field is 3-D, although No Fix may show when the antenna is temporarily blocked or in a garage.



- Precision: should be a value equal to 2 or less
- Satellites: should show a value of 5 or more (**Note:** it is the first value shown)

If the vehicle is in the open with a clear view of the sky (no metal roof above), the mode should show 3-D. The Last Update time should be current, Precision should be <2 and at least 5 Satellites should be used in the fix. If this is not the case, follow the steps below:

1. Verify the IVG display is in a location where the view to the sky is not blocked or obstructed.

Check for any metal obstructions that may block or degrade the GPS signals, such as wires or cables directly above the display. If there are any obstructions, remove the obstructions or relocate the antenna.

The GPS screen has a couple of indicators which may point to a problem with obstruction:

- The Precision value should be <2. If it is consistently above 3.00, there is likely something interfering with the GPS signals.
- The Satellites field shows xx/yy, where xx is the number of satellites used in the position fix, and yy is the number of satellites recently viewed. The xx value should be 5 or greater. If it has a value less than 5, there is likely some obstruction.

## J1587 Packet Detection Problem

### Problem: J1587 Packet Detection Fails

The engine must be running for the IVG system to pickup vehicle data.

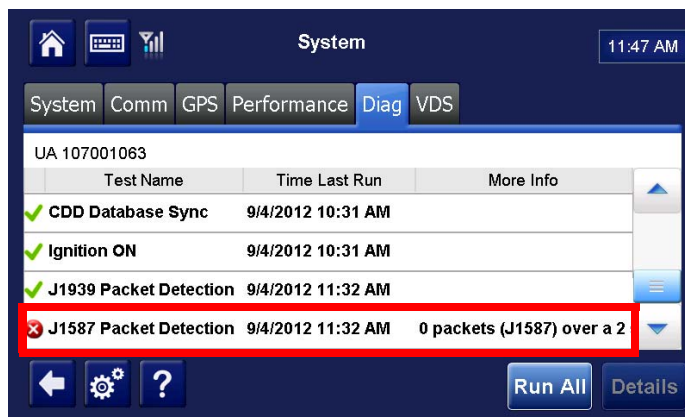

**Note:** If the **Core Data Items** and **J1939** tests pass (i.e. green check), it's acceptable for the **J1587 Packet Detection** test to fail. This would mean that the IVG system is getting its vehicle data from the J1939 link. Some 2012 and newer trucks do not supply J1587 packets.

In order to get J1587 data, a truck's engine must be supplying the J1587 data, a connection must be made to the J1587 wires (power I/O cable). Many new trucks/engines do not transmit J1587 packets.

If packets are not detected, check and reset the power I/O "Y" connections at the truck's diagnostic plug.

**Note:** the IVG system will auto-detect bus traffic, including J1587 bus traffic, and automatically select the most reliable source for vehicle data.





## J1939 Packet Detection Problem

### Problem: J1939 Packet Detection Fails

Ignition must be on for the truck to broadcast/supply vehicle data.

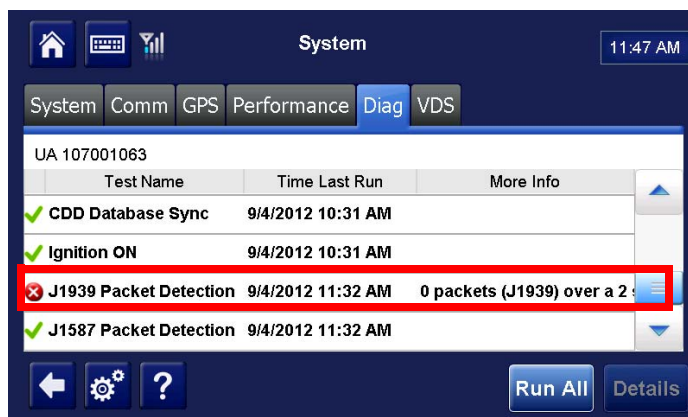

**Note:** If the **Core Data Items** and **J1587** tests pass (i.e. green check), it's acceptable for the **J1939 Packet Detection** test to fail. This would mean that the IVG system is getting its vehicle data from the J1587 link. Many pre-2007 trucks do not submit J1939 packets.

The IVG system will auto-detect bus traffic, including J1939 bus traffic (250 kbps and 500 kbps), and automatically select the most reliable source for vehicle data.

In order to get J1939 data, a truck's engine must be supplying the J1939 data, a connection must be made to the J1939 wires (power I/O cable). Many old trucks/engines do not transmit J1939 packets.



## Problem: Ignition On Test Fails

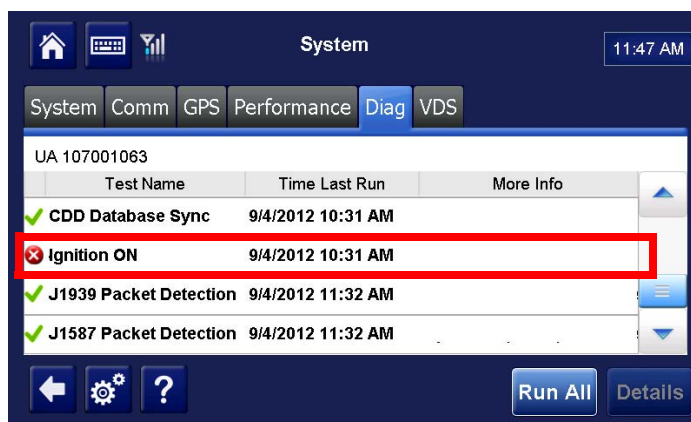

An IVG system will auto-detect when the ignition is on by identifying increased truck voltage and detecting engine RPMs. The engine must be running for the system to detect ignition is ON.

1. If the Ignition On test fails, it may be necessary to ensure the truck's engine is running:
  - It may be necessary to connect the ignition lead of the power I/O cable to a 12 VDC key switched to source. Ensure that wire is connected and secure.
  - Verify the fuse in the ignition wire has not blown.
2. If it continues to fail, check the ignition source used and the associated truck fuse. Using a digital volt meter, verify that the source has approximately 12 VDC when key is in the ignition ON position and shows 0 VDC in the OFF position.



### WARNING

*You must connect the IVG ignition wire to a true switched ignition source, not an accessory source.*

*To confirm a true ignition source, use a digital volt meter to verify that the source has approximately 12 VDC when the key is in the ignition ON position and shows 0 VDC in the OFF and accessory position.*

**Note:** Many newer model trucks have multiplex wiring systems that require specific ignition connection points. To ensure correct ignition connection points, refer to the individual Truck Specific Installation Instructions for more details.



### Problem: Core Data Item Test Fails

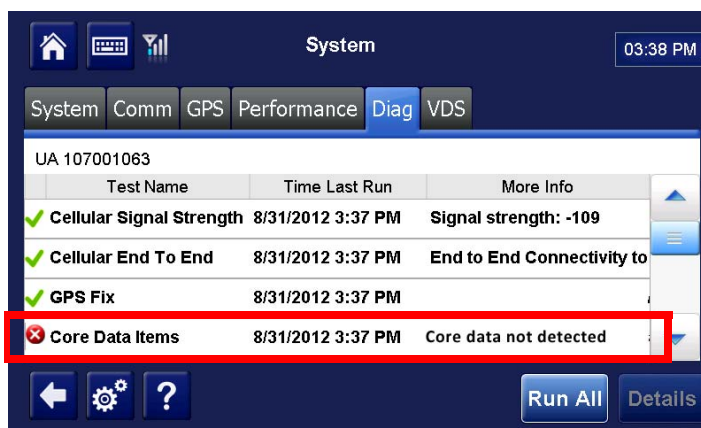

The Core Data Items test verifies that specific engine items are being received from one or both of the data links (J1587/J1939). Those items are:

- Speed
- RPM
- Distance LTD
- Fuel LTD

If any of these items are not received when the test is run, a failed status will be displayed (red X).

To identify missing data items, as well as detected data items, tap the **Core Data Items**, and then tap the **Details**.

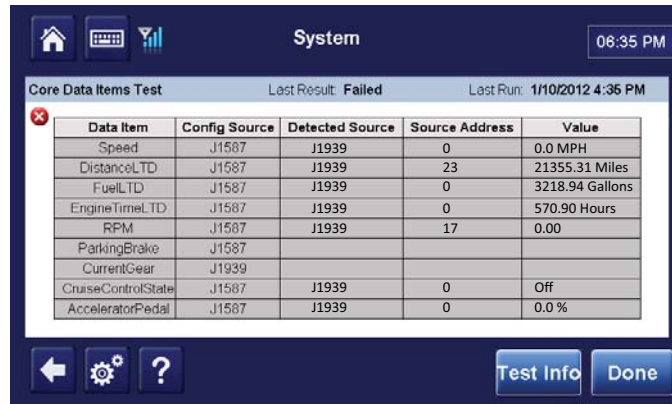

Data Item	Config Source	Detected Source	Source Address	Value
Speed	J1587	J1939	0	0.0 MPH
DistanceLTD	J1587	J1939	23	21355.31 Miles
FuelLTD	J1587	J1939	0	3218.94 Gallons
EngineTimeLTD	J1587	J1939	0	570.90 Hours
RPM	J1587	J1939	17	0.00
ParkingBrake	J1587			
CurrentGear	J1939			
CruiseControlState	J1587	J1939	0	Off
AcceleratorPedal	J1587	J1939	0	0.0 %

1. Verify if ignition test passes. The engine must be running. If the ignition test does not pass, see [Chapter 18: Ignition On Detection Problem](#).
2. Verify one of the J1587 or J1939 packet detection tests passes. This means that the IVG system is getting data from at least one data source.
  - Check connections.
  - If J1587 fails, see [Chapter 16: J1587 Packet Detection Problem](#).
  - If J1939 fails, see [Chapter 17: J1939 Packet Detection Problem](#).
3. If IVG is receiving data and the core data item test still fails, call Omnitrac's customer support at 800-541-7490 for assistance.

### IVG Display Performance—LED Indicators

In a normal operating environment:

- The top LED will be blinking blue.
- The middle LED will be blinking green:

<b>State</b>	<b>Top LED</b>	<b>Middle LED</b>	<b>Bottom LED</b>	<b>Action</b>
Normal Mode	Blinking blue once per second	Blinking green once per 3 seconds	Not available	None
Sleep Mode	Blinking blue once every 12 seconds	OFF	Not available	None
Boot up and System Recovery Mode	Red and blue blink. <b>Note:</b> this should last no more than five minutes	A Red LED will blink ON and OFF at irregular frequencies. <b>Note:</b> this should last no more than 5 minutes.	Give unit five minutes to boot or recover	Give unit five minutes to boot or recover





# IVG Display Icons and Indicators

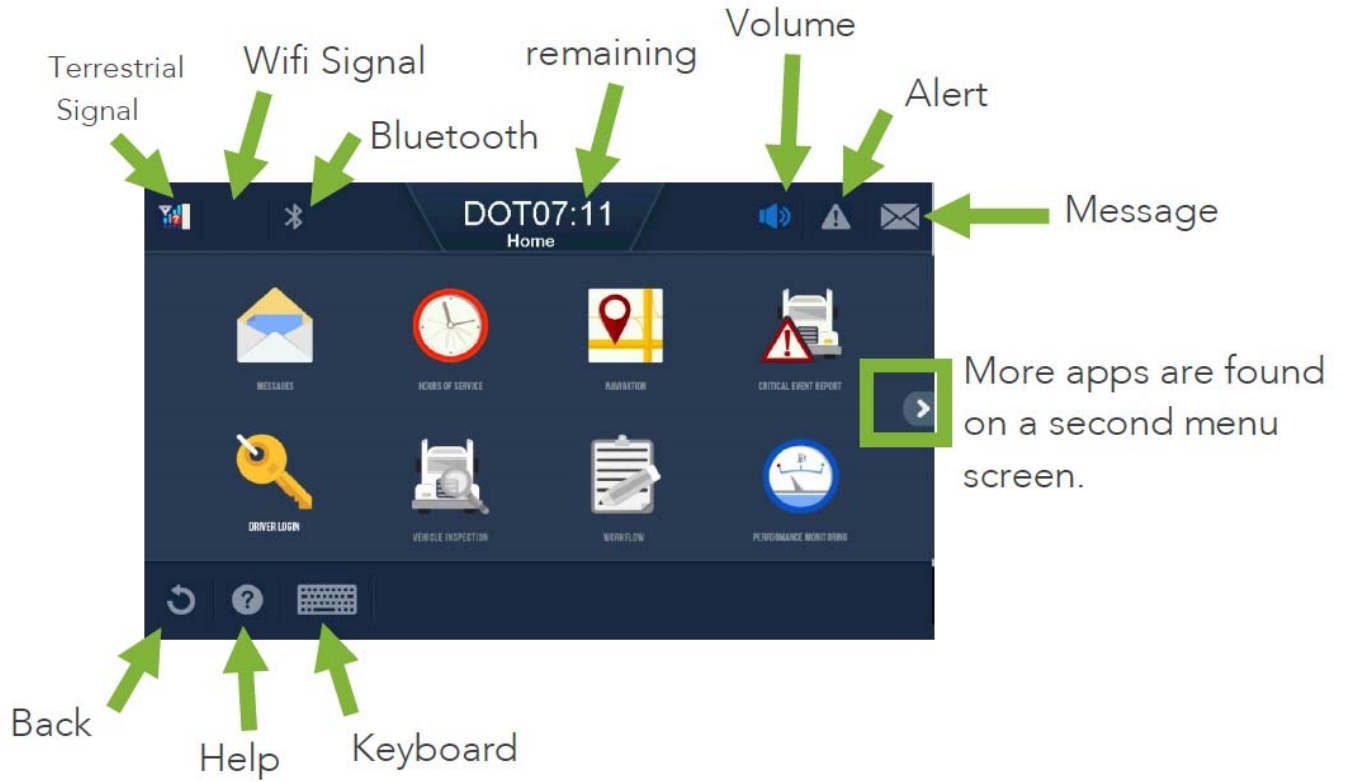



## Performance Monitoring Troubleshooting

### System Overview

Connecting to the truck's data link using the power I/O cable is required for the Performance Monitoring application.

The Performance Monitoring application records data from the vehicle such as speed, distance, RPMs, and total fuel used. The data is retrieved from the truck by the IVG and sent to the host computer, either manually or automatically at preset intervals.

The hardware installation on the vehicle consists of connecting the IVG power I/O connector to the truck's diagnostic connector.

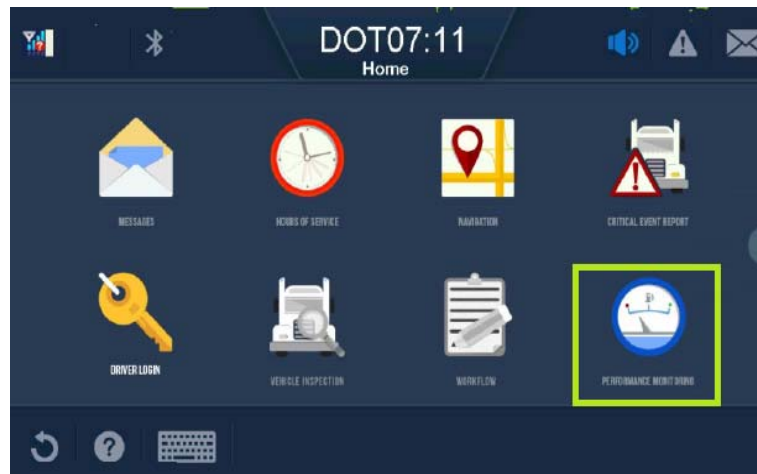

**Note:** If the **Performance Monitoring** icon is grayed out, the Performance Monitoring application is not enabled. Call your **company dispatch** to have this application enabled.

### Normal Performance

After the power I/O connection to the truck's diagnostic connector has been made, company-defined parameters are sent and received by the unit, performance monitoring data will be recorded at the mobile and sent to the host system.

To confirm normal performance, first verify that performance monitoring parameters have been sent to the unit and received. Tap the **Parameters** tab within the Performance Monitoring application and verify the tag field is not "0."

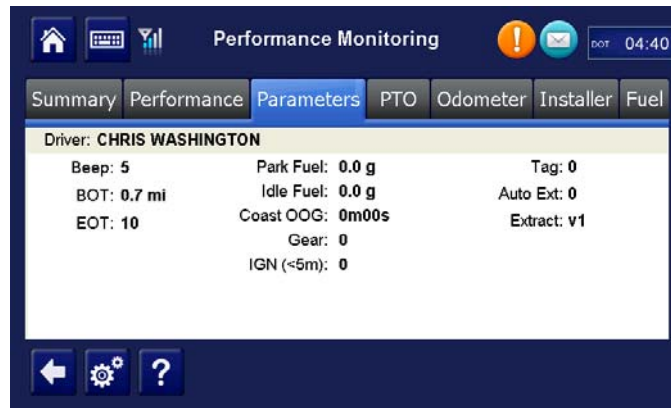

A tag of “0” indicates that the unit has not received its parameters. Call your company dispatch administrator and ask for the parameters to be sent. A non-zero tag indicates that the unit has received parameters.

The Core Data Items test checks for all essential data items for Performance Monitoring. With the engine running, review data that is available listed under the **System>Diag** tab **Core Data Items>Details**.

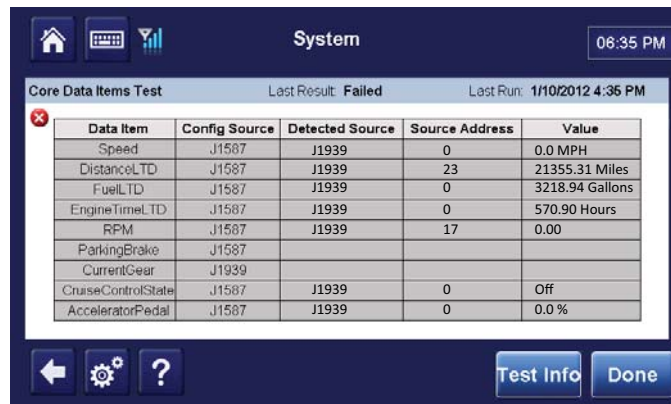

At a minimum, Performance Monitoring needs current data from Speed, EngineRPM, Fuel, and DistanceLTD. These are checked when a system verification is run. The core data items verifies these are received. The screen above shows how the unit is configured, if an item is detected, and the source address if detected.

If any data items are not present:

- Ensure the IVG is set to auto-detect for the right databus traffic by calling the Omnitracs Customer Support at 800-541-7490 for assistance..

If problem persists, contact Omnitracs Customer Support at 800-541-7490 for assistance.

### Performance Monitoring Faults and Descriptions

Monitored Active Faults are controlled by the customer-specified parameters sent to the unit. The following chart shows the faults that may surface.



<b>Active Fault Field Value Definitions</b>			
<b>Display Shows</b>	<b>Associated Fault</b>	<b>Description/Symptom</b>	<b>Possible Cause</b>
+		Fault no longer active	Cleared
-		Fault not monitored	Performance monitoring parameters specified not to monitor.
0	No Power (IVG)	Power detected OFF for more than the wake-up time.	Main power was lost, causing the IVG to stay asleep longer than its wake-up interval.
1	RPM Zero (IVG)	RPM zero when speed is non-zero.	<ul style="list-style-type: none"> <li>- RPM sensor or connection problem.</li> <li>- J1708 selection parameter set wrong.</li> <li>- In rare cases, no idle can be caused by faulty axle sensor input (e.g., wires reversed) causing a positive reading for speed while the vehicle is stationary.</li> </ul>
2	Bad Ignition (IVG)	Ignition OFF and speed or RPM non-zero.	Problem with the IVG's ignition sense or unit rebooted while moving.
3	RPM Sensor (IVG)	Engine posted PID (194) and PID (190).	RPM sensor or connection problem to the engine, detected by the engine's diagnostics.
4	Speed Sensor (IVG)	Engine posted PID (194) and PID (84).	Speed sensor or connection problem to engine, detected by the engine's diagnostics.

<b>Active Fault Field Value Definitions (Continued)</b>			
<b>Display Shows</b>	<b>Associated Fault</b>	<b>Description/Symptom</b>	<b>Possible Cause</b>
9	LTD Mismatch (IVG)	LTD mismatch with stored IVG data.	<ul style="list-style-type: none"> <li>- Engine run with main power disconnected.</li> <li>- Engine run with data link disconnected.</li> <li>- Engine run with ignition line disconnected.</li> </ul>
A	Bad Speed (IVG)	More than 2 hrs IGN = ON with Spd = 0, RPM greater than 1300.	<ul style="list-style-type: none"> <li>- Speed sensor or connection problem: engine.</li> <li>- Engine speed sensor parameter not enabled.</li> </ul>
B	0 Spd and RPM (IVG)	More than 2 hrs with IGN = ON with Spd = 0, RPM = 0.	<ul style="list-style-type: none"> <li>- Data link connection problem</li> <li>- IVG detection of ignition problem.</li> </ul>
D	IVG Speed (IVG)	Speed signal constant for more than 5 minutes.	A pulse generator may have been connected to either the IVG or the engine.
E	Hard Braking Event	Speed is suddenly decreased by more than 9 MPH/second (speed must be above 20 MPH for this fault to occur).	Driver is braking too quickly (hard braked).

## ***Critical Event Reporting Troubleshooting***

---

### ***Overview***

Critical Event Reporting (CER) captures and reports vehicle critical event information (e.g., hard braking, vehicle speed, location, stability control (VDC), lane departure warning (LDW), and panic button events). With each hard braking event, five minutes of speed information is recorded and sent to the CER host system. Events are processed two minutes after they occur.

### ***Normal Performance***

In order for the CER feature to function, the IVG must be connected to the vehicle's data link via the power I/O cable.

Critical events can be triggered by a:

- Hard Brake event
- Stability Control event (if available)
- Lane Departure Warning (LDW) (if option is installed)
- Manually triggered CER event.

Text-to-speech (TTS) can be enabled so CER events can be audibly conveyed to the driver.

### ***Abnormal Performance***

If any of the above items do not trigger a CER event, or if a critical event is reported in error, there is a problem. A problem is usually caused by one or more of the following:

- Loose or bad connection to the data link
- Intermittent data supplied by stability control device or lane departure warning device
- Intermittent data supplied by ECM of vehicle

## Event Not Triggered

### CER Verify Configuration

1. To access CER information, go to the **Home** screen and tap the **Critical Event Reporting** button. If this button is grayed out, then CER service for the unit must be enabled from the Customer Portal.



2. A pop-up will appear. Tap the **Diagnostics** button at the bottom right of the screen.

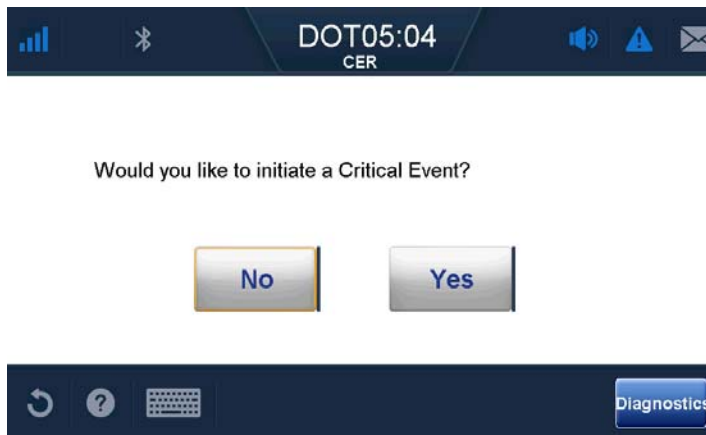

3. Select one of the tabs for General, Roll Stability, Lane Departure information, or Collision Warning.



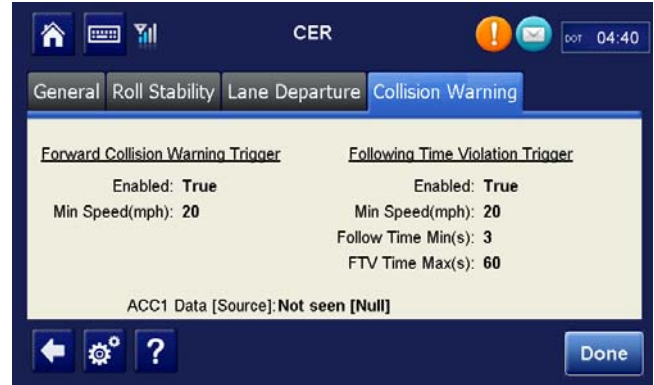
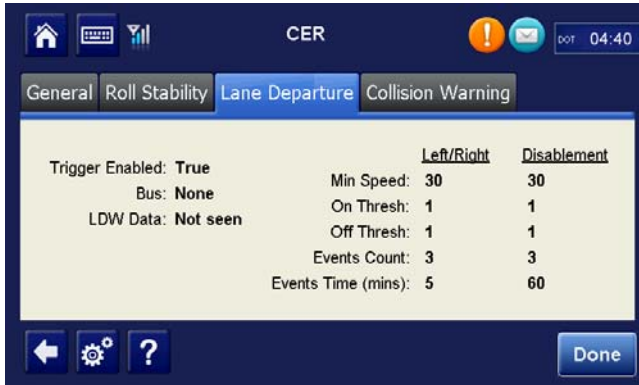
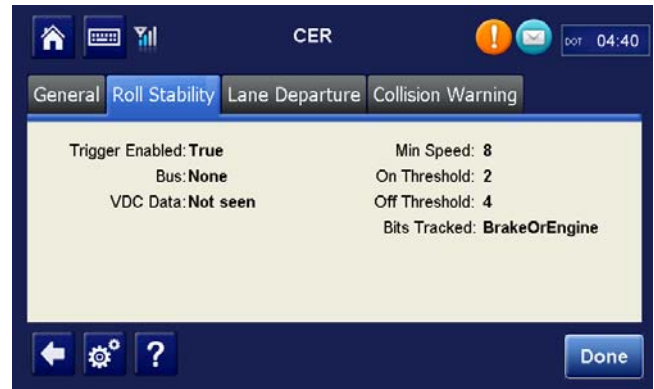
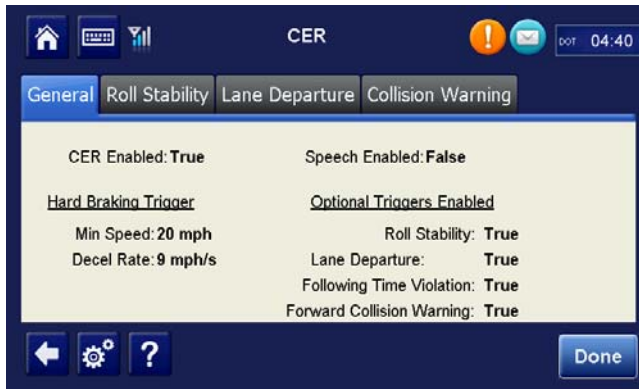

<b>Field</b>	<b>Value</b>
CER Enabled/Disabled	If enabled, the IVG captures CER events.
Speech Enabled/Disabled	If enabled, the text in the alert pop-ups is spoken.
Hard Braking Minimum Speed	The speed at which mobile unit detects hard brake events.
Hard Braking Deceleration Rate	The rate of deceleration that triggers a hard brake event (Default = 9 MPH/SEC).
Stability Control (VDC) Enabled/Disabled	Stability control is enabled/disabled.
Minimum Speed	Minimum speed at which mobile unit detects events.
On/Off Threshold	Number of notifications that must be seen in a row before an event is considered to be in progress.
VDC/LDW Bits Tracked	Setting that determines which bits the mobile unit tracks to monitor stability control events: Brake bits only, Engine bits only, Brake or Engine bits (Default), Brake and Engine bits
Lane Departure Enabled	Lane Departure Warning is enabled.
Bus	J1587 or J1939
VDC/LDW Data	Available or not seen
LDW Events Count	Number of LDW events that occur within the LDW Time Threshold before CER sends a notification.
LDW Events Time (mins)	Number of minutes that pass before LDW events are detected and CER sends a notification.

Hard braking gets information from either J1708/1587 or J1939. One of the two indicator lights must be green to record hard braking events correctly. Some filtering is done to prevent erroneous CER events due to faulty truck speed sensors.

### ***Sending a Manual CER Event***

1. From the **Home** screen, tap the **Critical Event Reporting** button. Tap **Yes** to initiate an event.

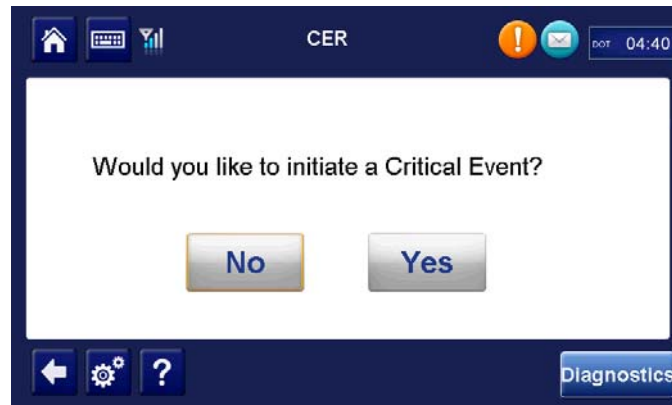

**Note:** The CER message is sent to the NOC.

2. Verify that the host receives the CER event message and that data is present.

### ***Events Triggered in Error***

- For hard braking events triggered in error, verify configuration values, hard braking minimum speed and hard braking deceleration rate.

**Note:** False hard braking events are typically caused by a faulty speed sensor.

- For stability control events triggered in error, verify configuration values minimum speed and on/off threshold.
- Roll stability events are sent from the power train or braking control units installed on the truck. The IVG system acts as a pass through for these devices. If false events are being recorded, those devices should be investigated.

### ***Trailer Tracks, Scanner, Panic Button (placeholders)***

•

***Optional Accessories Troubleshooting***

---

This section reserved for future use.



## ***Appendix Contents***

---

- A. Wiring Diagrams and Charts
- B. Environmental and Power Requirements
- C. General Wiring and Installation Guidelines
- D. Standard RMA Procedure
- E. Upgrading the IVG Using USB Memory Sticks
- F. Preventive Maintenance Inspection
- G. Component Information
- H. Installation Form
- I. RF Exposure Information (SAR)



# Wiring Diagrams and Charts

## IVG Wiring Diagram

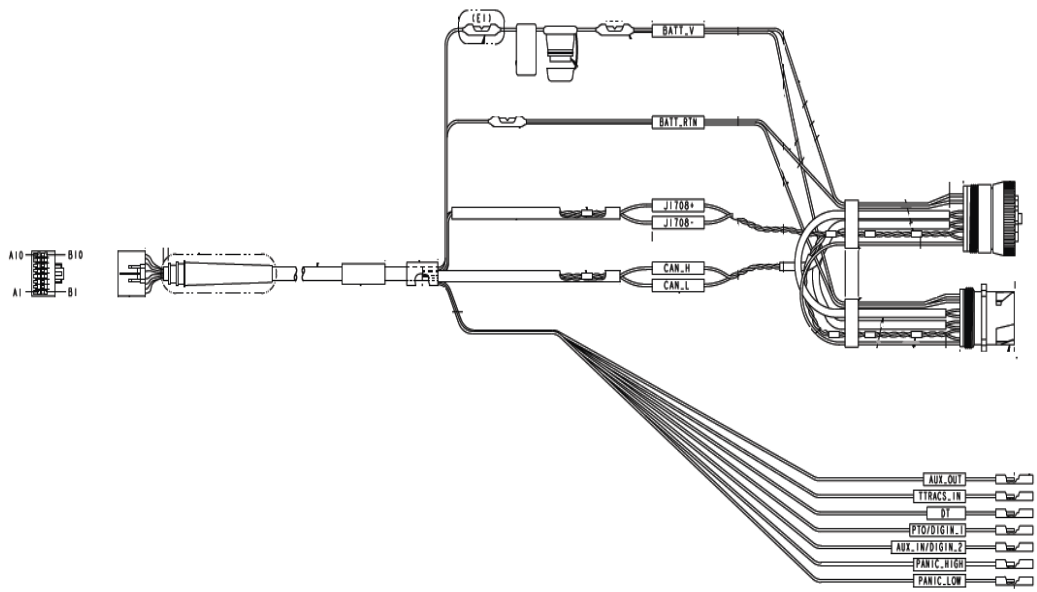





### 6-pin Power/IO Cable

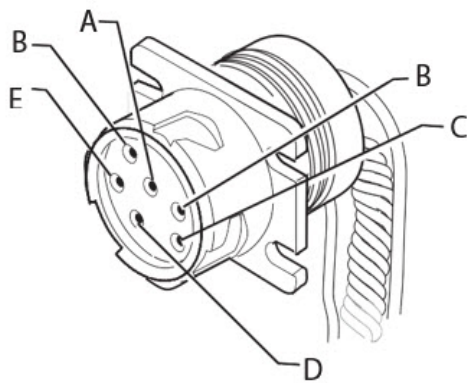
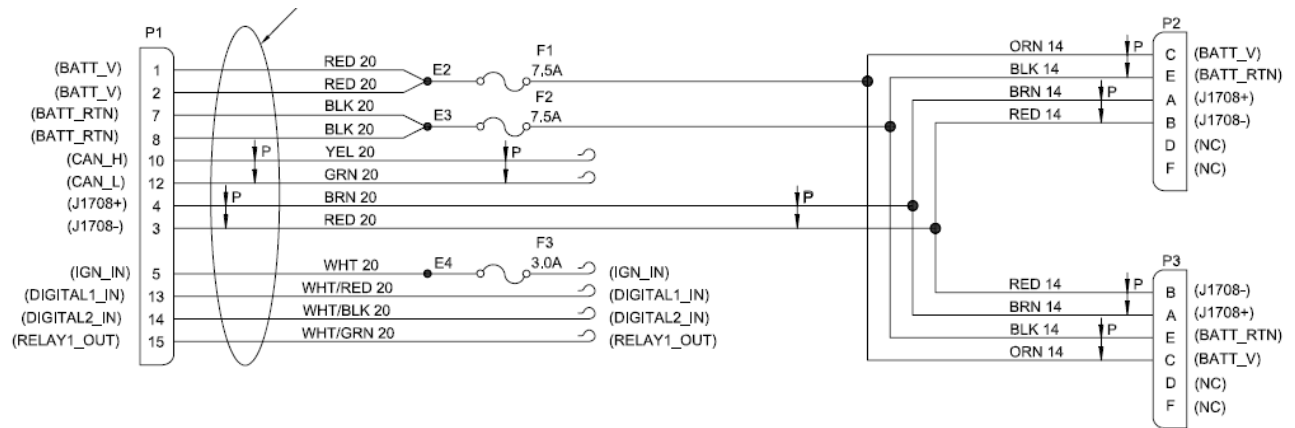

SIGNAL	PIN
J1708/J1587 DATA LINK+	A
J1708/J1587 DATA LINK-	B
+12VDC	C
N/C	D
BATTERY GROUND	E
N/C	F

### 9-pin Power/IO Cable and Paccar Adapter Cable

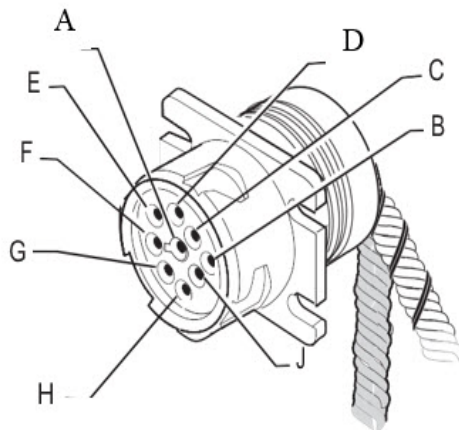
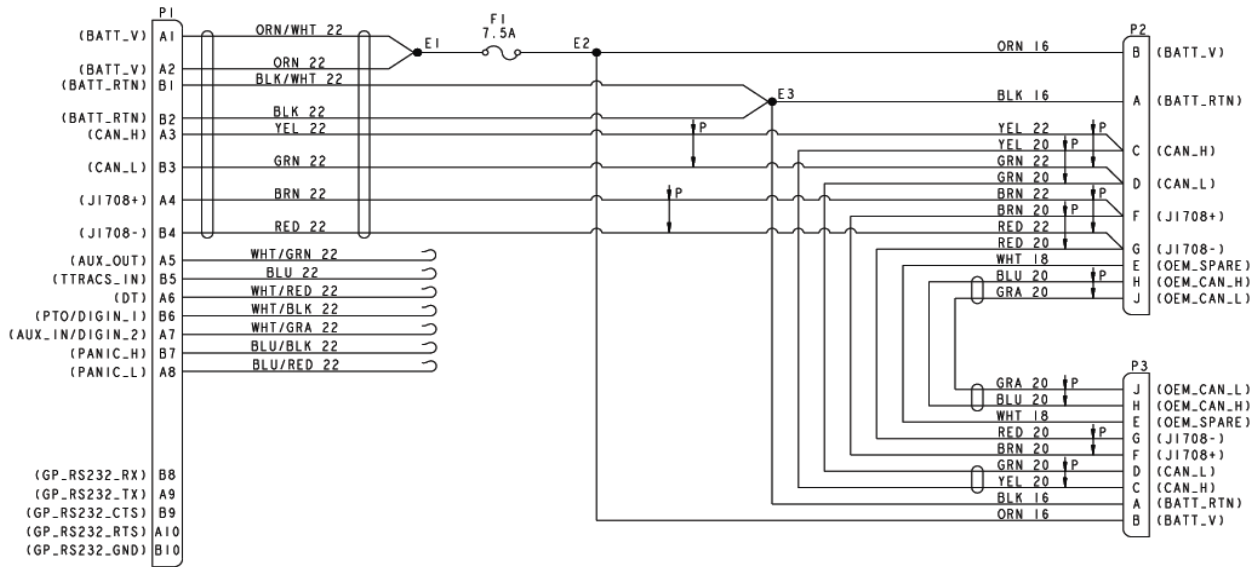

SIGNAL	PIN	SIGNAL	PIN
BATTERY GROUND	A	J1708/J1587 DATA LINK+	F
+12VDC	B	J1708/J1587 DATA LINK-	G
J1939 DATA LINK+	C	OEM_CAN_H	H
J1939 DATA LINK-	D	OEM_CAN_L	J

### Volvo/Mack 2014 or newer OBDII style Connector

**Note:** While this cable uses OBDII style connector, it is not compatible with standard OBDII cables found in most non-commercial cars, trucks, and vans.

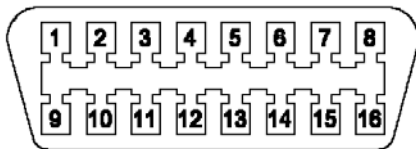
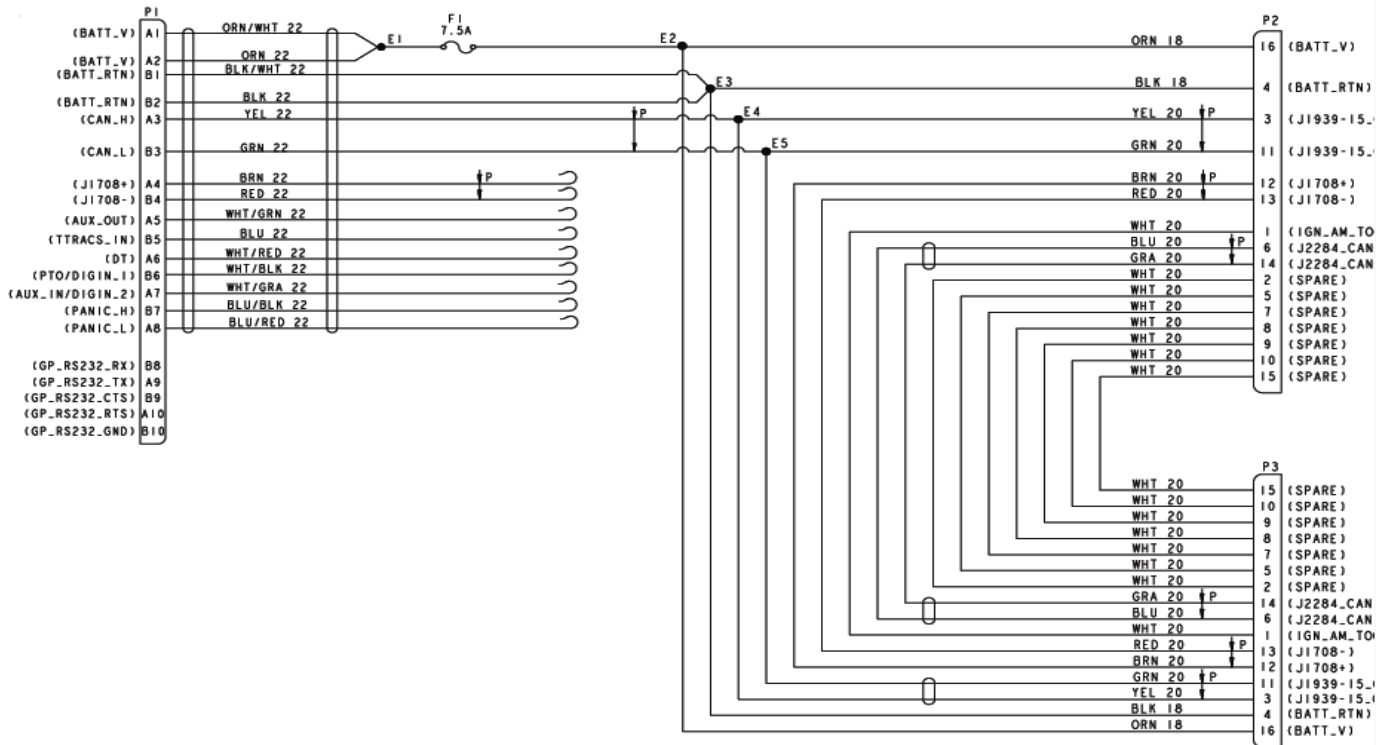

SIGNAL	PIN
Ignition	1
J1939 CAN (High)	3
Chassis Ground	4
Signal Ground	5
J1939 CAN (Low)	11
J1708/J1587 Data Link +	12
J1708/J1587 Data Link -	13
Battery Positive Voltage	16

**Hino**

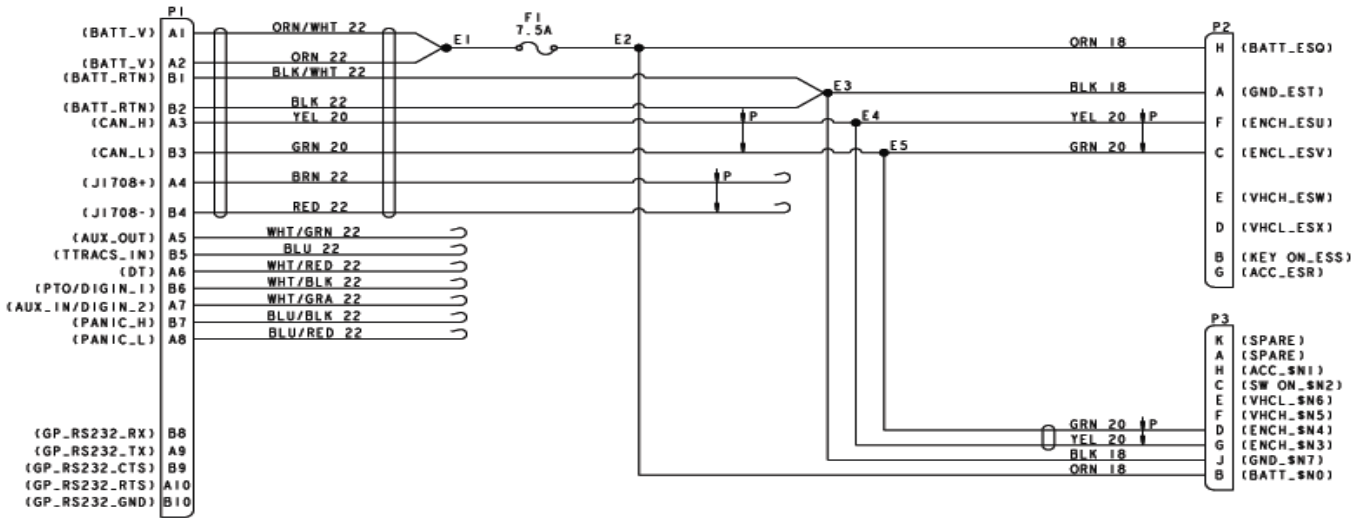

P2: Blue US-built vehicle

P3: White: Japanese-built vehicle

SIGNAL	P2	P3
Battery	H	J
Chassis Ground (batt return)	A	B
CAN high	F	G
CAN low	C	D
Ignition	B	C

**J1939 500 Kbps Cable (placeholder)**

**Environmental and Power Requirements****IVG Environmental and Power Requirements**

<b>Condition</b>	<b>Requirement</b>
Operating Temperature	-30° C to 70° C (-35° F to 158° F)
Vibration/Shock	
Humidity IVG Display	Not watertight. DO NOT get wet.  Not watertight. Turn over immediately if liquids are spilled on it.
Power	+6 to +18 Volts DC
Operating at +12V (IVG display)	IVG draws a maximum of 2 amps. Average current draw is approx. 1 amp.
Asleep	IVG draws 10 mA.
Frequency of modems	800 MHz 1x 1900 MHz EVDO (when supported)

The IVG system has no user-serviceable parts. The IVG display contains a permanent lithium coin cell for maintaining the real-time clock; proper recycling or disposal per local law is required for all components of the IVG.



## General Wiring and Installation Guidelines

### Making Electrical Connections - Standard Installations

For standard IVG installations, the only electrical connection needed to the truck will be the power I/O cable and an ignition wire lead.

### Cutting and Splicing Power I/O Cable - Non-standard Installation

Some trucks may use a different 9-pin diagnostic connector than supplied on the Omnitrac's "Y" cable. The connector on the Omnitrac's cable may not easily mount in the dash. Therefore, it may be necessary to make direct butt splice connections.

If the available power I/O cable does not mate to the truck's diagnostic connector, the "Y" portion of the cable can be cut off and the leads spliced into an appropriate source:

#### Cable

BATT\_V  
BATT\_RTN  
J1708+  
J1708-  
Can\_H  
Can\_L

#### Truck

12 VDC unswitched source  
Chassis ground  
Positive J1587/J1708 truck wire  
Negative J1587/J1708 truck wire  
J1939+ truck wire (yellow to yellow)  
J1939- truck wire (green to green)

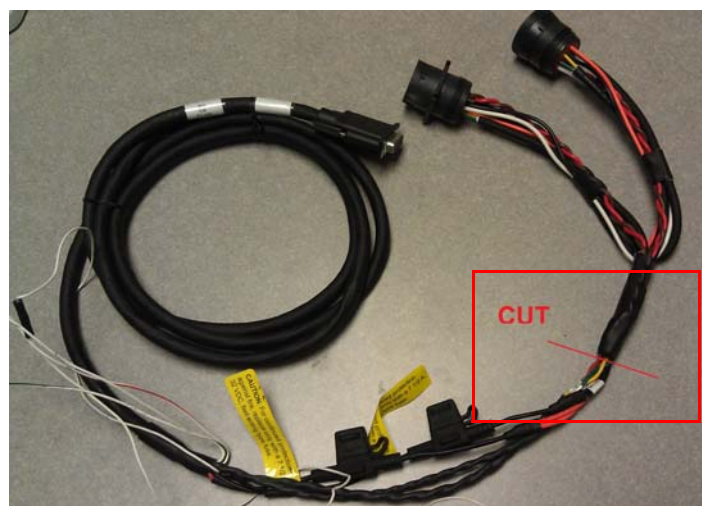

## Approved Omnitrac Electrical Connectors

The wiring for the IVG system is expected to be inside the cab. The only Omnitrac-approved electrical connections other than standard connectors are crimp butt splices and crimp ring terminals. Connections are typically made by mating the two connectors. Many of the following general guidelines apply to non-standard IVG connections where the power I/O cable must be cut because it does easily mount in the truck's dashboard.



### Caution

*Not following proper wiring guidelines and using improper crimps and butt splices may cause intermittent connections and may result in unexpected truck down time or system failure.*

---

## Wire Stripping



### Caution

*Use care in stripping wires. Vibration can cause nicked wires to fail. Using wire cutters, knives, or other tools can damage the conductor wire and/or insulation.*

---

Knowing and following proper wire stripping techniques is essential for performing successful and safe electrical connections of all system components.

1. Using a wire stripper, strip approximately 1/4" off the end of an insulated wire.

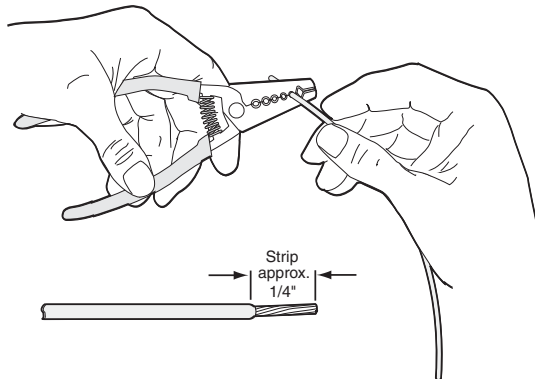

2. After stripping the wire, verify that the wire is not severed, nicked, or damaged by the stripping tool. If the wire has been properly stripped, it is ready to be butt spliced. If the wire has been damaged, restrip the wire (see [step 1.](#)).



### **Butt Splicing**

- Omnitrac recommends Nylon insulated, seamless butt connectors with inspection windows.
- Heat-shrinkable butt connectors are preferred.

Make sure the size of the butt splice is appropriate for the job. A good butt splice has these characteristics:

- The ends of the bare wires are visible through an inspection window.
- The ends of the wires “butt” up against the stop.
- The wires are not exposed beyond splice shielding.
- Crimping does not sever or damage the wires or insulation.

### Crimping

- When crimping a butt-spliced wire or cable, be sure the insulated butt splice is crimped using the insulated position on the crimp tool and not the crimping “tooth” of the tool.
- Crimping butt splices incorrectly can result in a severed wire and a failed wire connection.

---

 **Caution**  
**DO NOT crimp on the crimp “tooth.”**

---

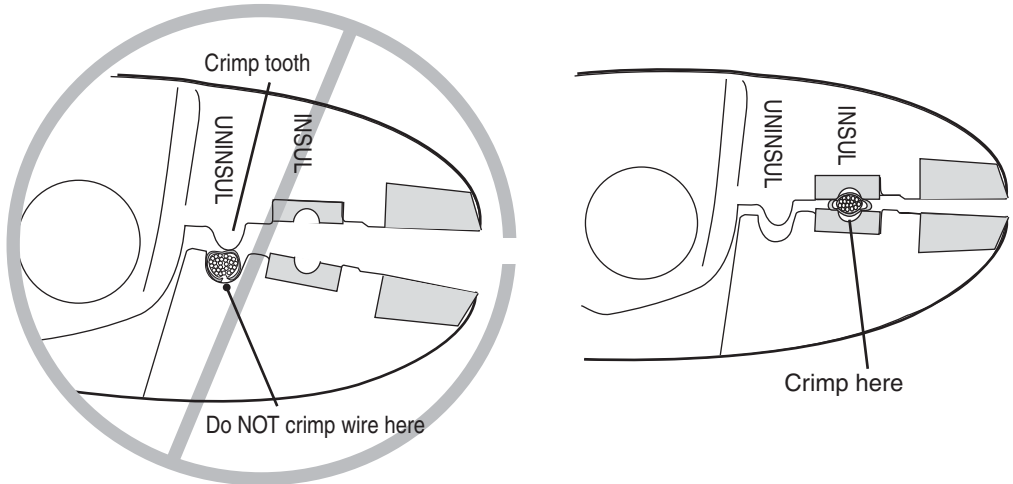

03AAA\_90b

1. Using a crimping tool, crimp the butt splice one end at a time. **First**, crimp the inside crimp area where the wire has been stripped. Apply necessary pressure to this inside area.

**Note:** The objective is to apply the necessary pressure to crimp the butt splice closed and hold the wire connections together. **Do not** apply so much pressure as to crush the butt splice and sever the wire or the insulation on the wire.

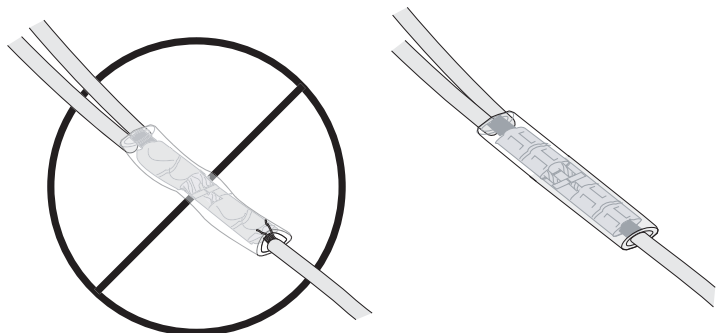

**WRONG**  
 Butt splice is visibly crushed, possibly damaging the wire and the wire connection.  
 Some wires are exposed.

**CORRECT**  
 Crimping is done properly, protecting the wire and the wire connection.  
 No exposed wires.

03AAA\_277A

2. After crimping the inside of both ends of the butt splice on the “insulated” area of the crimping tool, next crimp the outside of both ends of the butt splice.

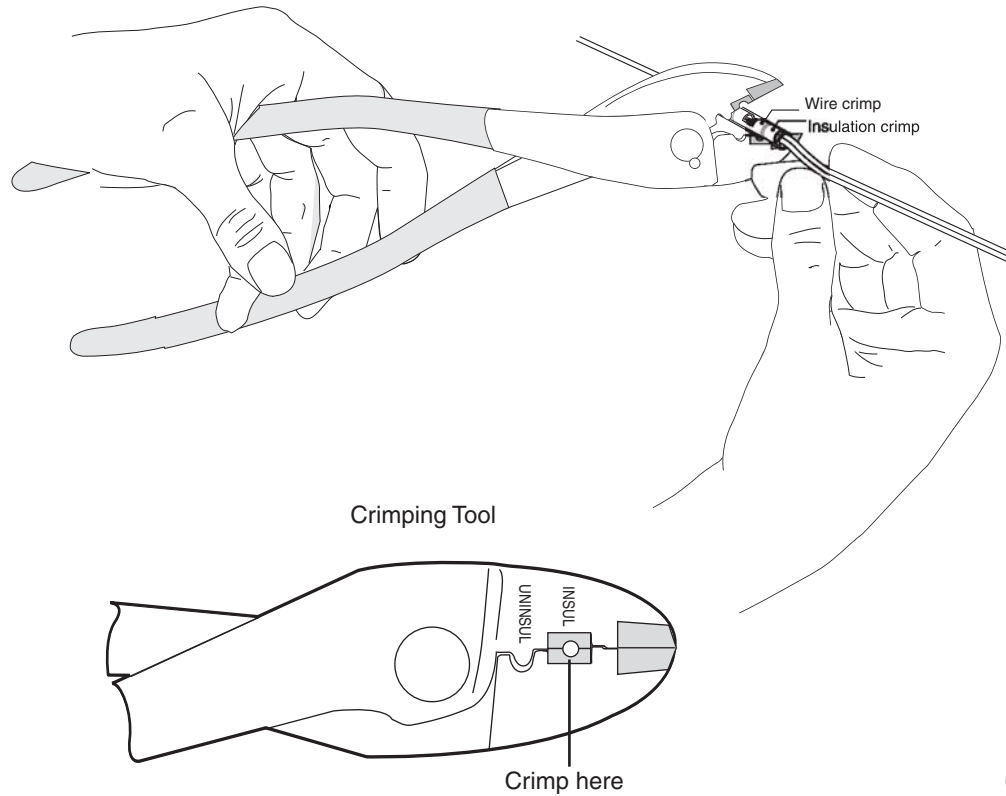

03AAA\_271

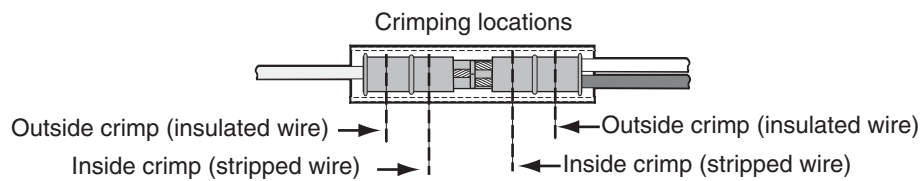

03AAA\_273

3. Verify that the crimps are good and the wires have not been damaged.

- Do a pull test. Pull on both ends of the wires to ensure a solid butt-spliced connection exists. The crimped butt splice securely grips the insulated wires.

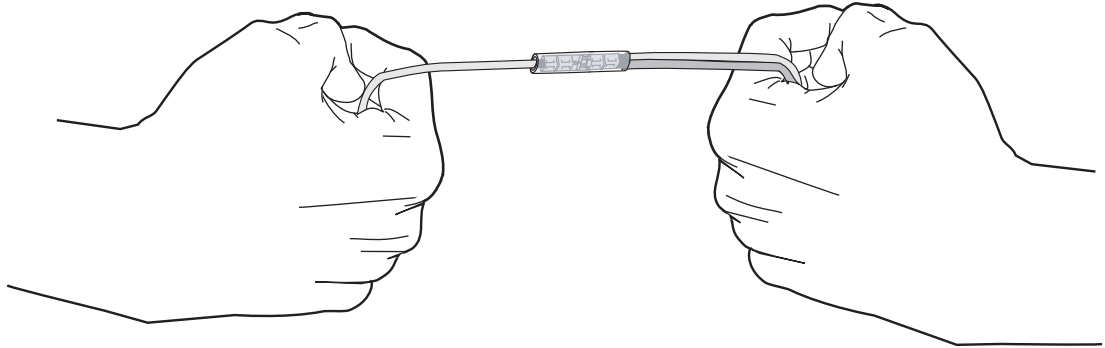

03AAA\_282

**WARNING**

*If using heat shrinkable crimps, DO NOT use a heat gun or open flame near combustible materials. Use a heat gun only when it is safe and appropriate to do so. Protect surrounding wiring and other components when using a heat gun.*

**Ring Terminals**

When making electrical connections, crimp ring terminals onto the ends of the wires to ensure good contacts. A properly crimped ring terminal has these characteristics:

- The barrel crimping indent is well-formed and properly positioned.
- The insulated wire's grip impression is well-formed and provides proper support without crushing the insulation.
- The wire does not move independently of the lug. Firmly tug on the ring terminal to ensure it does not pull loose.
- The end of the bare wire protrudes through the crimp barrel approximately 0.03 to 0.125" depending on the lug size and crimp tool.

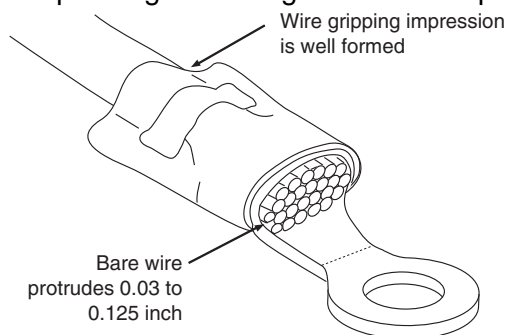

OM/E-0093-97

Install the ring terminal on the ground connection using one of the following options:

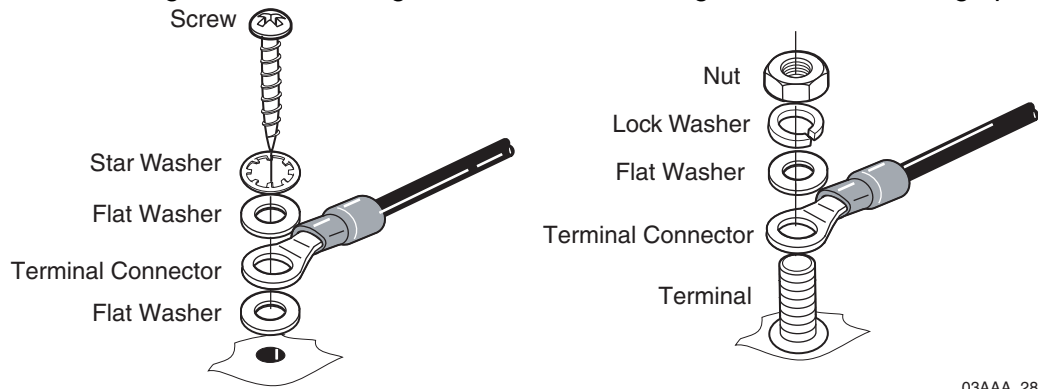

### Proper Grounding

When establishing a good chassis ground, avoid areas that may be potentially isolated from ground by a hinge or bad welds. It is extremely important that you create clean, secure, tight, metal-to-metal grounds. If grounding terminals are not available, remove the paint from the surface of the metal connected to the chassis to make the ground. Make sure the wires are not strained or vulnerable to damage.



**WARNING**

*Not following proper grounding guidelines may cause intermittent connections and may result in unexpected truck downtime or system failure.*

## **General Installation Guidelines**

- Determine the most direct and protected route when routing cables to connect the components to each other and to the vehicle.
- Do not trim cable lengths to fit a specific vehicle.
- Use only wire strippers for stripping wires.
- Use only the appropriate insulated crimping tool for crimping insulated connectors.
- Use existing holes for cable routing whenever possible.
- Avoid running cable over or near heat sources.

## **Routing and Protecting Cables**

- Provide strain relief for all cables
- Use tie wraps
- Debur any drilled holes

DO NOT route cables:

- Near audio system amplifiers
- Near exhaust pipes and other sources of heat
- Near the brake, clutch, or accelerator pedals, and linkage
- Near foot traffic areas
- Near the windshield wiper mechanism
- Near CB radio wires
- Over sharp edges
- Over moving parts

## **Special Interior Routing Guidelines**

- Route cables under kick plates or carpets.
- Avoid high foot traffic areas.
- When reinstalling dash panels, be careful that screws do not penetrate cables.
- Route cables with any existing vehicle cables.

## **Storing Excess Cabling**

- Secure excess cabling with tie wraps.
- Stow out of sight.

## **Stress Relief**

- Ensure cables have enough slack so connections are not being pulled.

# **D**

## **Standard RMA Procedure**

---

**For customers, to return failed equipment, go to Omnitracs Customer Portal at <https://customer.omnitracs.com>**

For service centers only, please return equipment to Omnitracs at the following address. Make sure that the RMA number is marked clearly on the outside of the box.

Omnitracs, LLC - RMA Receiving  
c/o Baja Freight Forwarders, Inc.  
8662 Siempre Viva Road  
San Diego, CA 92154  
RMA #: \_\_\_\_\_  
(800) 541-7490

To prevent damage during shipment and handling, carefully package all equipment being returned. If the original shipping container and packing material are available, please use them to return the equipment.





# **Upgrading the IVG Using USB Memory Sticks**

---

## **Before You Start**

During an OS or application upgrade, driver and vehicle information can be deleted. The list below will help minimize any inconvenience this causes.

- Confirm that the driver knows that all stored messages will be lost.

The driver should write down any information he thinks he may need later, from both his inbox and his outbox.

- Confirm that he has listened to any unopened audio files.

This is necessary only if your company uses Omnitrac's Media Manager application. Deleted audio files will not be resent to the vehicle.

- Determine if certain special services are enabled for this vehicle.

From the display unit's Home screen, check to see if the following services are accessible:

- Driver Workflow
- Content Delivery
- Hours of Service
- Navigation
- Performance Monitoring

## **Requirements for Certain Services**

For everything except Hours of Service and Navigation, there are required tasks that you or someone else must complete before the upgrade. If you don't, important data may be lost.

**Driver Workflow:** The trip plan and any pre-plans will be deleted during the upgrade.

- **Before:** The driver should write down the details of the next stop in the trip plan.
- **After the upgrade:** the driver should ask dispatch to resend the current trip plan and any pre-plans.

**Hours of Service:** Normally, no HOS data will be lost.

- **Before:** none. The driver's logs are sent to the company's HOS database when the driver logs off the unit.
- **After the upgrade:** the logs are automatically resent to the vehicle the next time the driver logs into HOS. Remind the driver that he needs to account for his time during the upgrade and record the proper duty status. Recommend that the driver pay special attention to that day the next time he approves the logs.

**Navigation:** The current route will be deleted during the upgrade.

- **Before:** None.
- **After the upgrade:** The driver needs to ask dispatch to resend the list of stops for the current trip.

**Performance Monitoring:** Performance Monitoring data on the unit is deleted during an upgrade.

- **Before:** Your company's System Administrator needs to take steps to ensure the data is not lost by manually extracting the performance data stored in the vehicle's IVG system. For the Omnitrac Services Portal, instructions are in *Performance Monitoring: Administration and Configuration Guide* (80-JA316-3). For AS/400®, they can refer to the *SensorTRACS/400 User's Guide, Version 2.3* (80-30597-4). Remind Operations that your Omnitrac representative can also help the System Administrators with this task.
- **After the upgrade:** Contact Operations and have a System Administrator resend the vehicle's Performance Monitoring parameters.

**Placeholder - new process screens available soon**

**Checking the Software Versions Installed**

Shortly after you power up the IVG, the user interface screen displays.

1. Use the right arrow to get to the **System** button. Tap the **System** button.



2. Tap the **System** tab to bring up the System Screen. Tap the **Version** button at the bottom right to access system information about the IVG.
  - IVG firmware and VIOP version numbers are listed here.

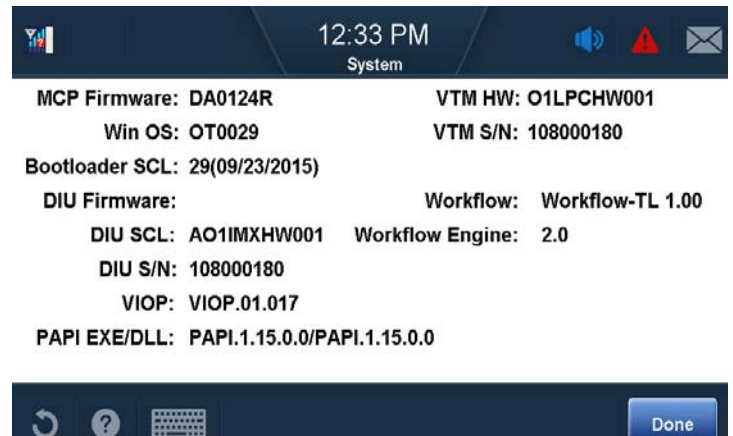
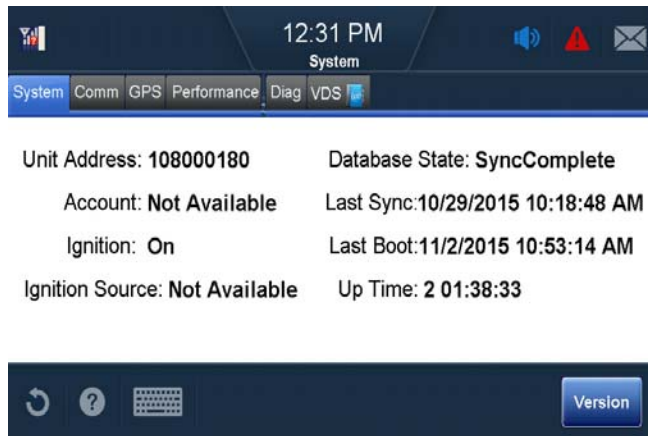

## Upgrading Only the IVG Firmware

1. Make sure the IVG is powered ON, ignition ON.

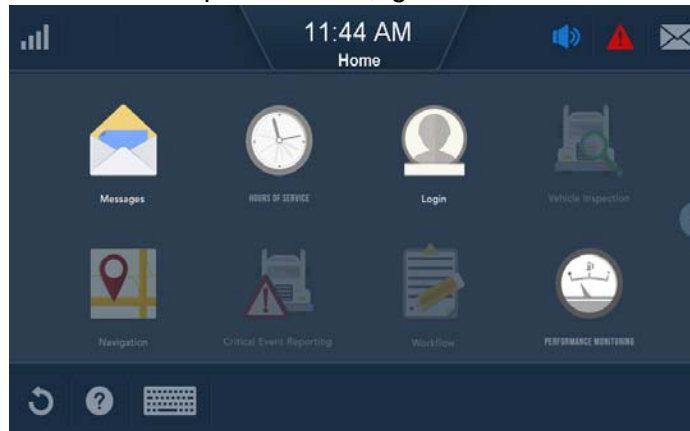

2. Insert IVG firmware memory stick into the USB port on the right side of the DIU.
  - The upgrade process takes approximately ten minutes. The screen will run through various images as it is upgrading. You may see a listing of components, various upgrade screens, a dark or fading screen, unit rebooting, acquiring network, network loading, and others. Be patient. It may appear that nothing is happening, but it the upgrade is going on in the background.
3. After the upgrade finishes, the IVG screen will show the Driver Warning screen. Tap **OK**.



4. Remove the memory stick.

5. Confirm the upgrade is complete by checking that it shows **SyncComplete** on the System screen and the IVG firmware version on the Version screen. Also verify that the VIOP is the latest revision (refer to the *IVG External Release Notes*).



6. If the display shows only a blinking cursor in the top left, the USB memory stick most likely has a separate boot sector. Remove the USB memory stick, disconnect power until all lights are out, and then power up again. The unit will upgrade normally.
7. Perform system verification.



## Preventive Maintenance Inspection

### How Often Should Inspections Be Performed?

- Omnitrac's recommends inspections be performed at least **once every 90 days**.
- During normally scheduled vehicle preventive maintenance inspections.

### Performing System Verification

- Verify proper IVG operation. From the Home screen, tap the **Diag** tab. Tap **Run All** button.
- Verify at a minimum that Cellular End To End, Cellular Signal Strength, CDD Database Sync, GPS Fix, and Core Data Items show green check marks.

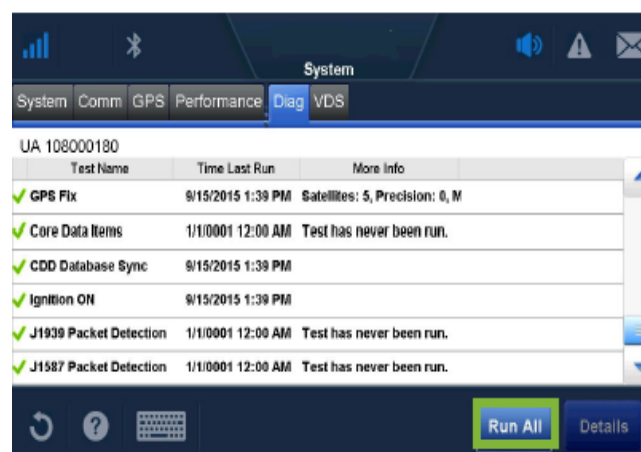
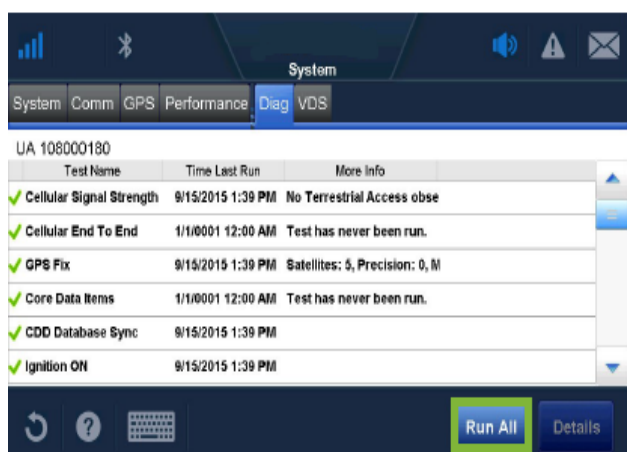

### Inspecting the IVG Unit

- Verify the IVG screen is clean.

Omnitrac's recommends that you use a soft cloth and either plain water, glass cleaner, or mild soap to gently clean the surfaces of the IVG as well as the display screen.



#### Caution

The IVG is not watertight. Do not spray any liquid directly on the display screen.

Heavily soiled IVG units should be returned to Omnitrac using the RMA process for proper cleaning.

**Note:** *Use the PDA stylus, provided with the unit, or your fingers to navigate the IVG display.*





*Do not use pencils, pens, metal objects, or any other devices which could possibly scratch the touchscreen.*





- Make sure the display cable is not a tripping hazard.
- Verify the display screen is readable in any lighting condition.
- Make sure the display cable has enough slack and is not being rubbed or cut by anything inside the cab.
- Remove the IVG from the holster and make sure the screws holding the holster in place are secure.



**Note:** *Display cable must not be removed from the IVG or warranty will be voided.*



**IVG System Component MCNs Referenced in this Guide**

<b>System component</b>	<b>Illustration</b>	<b>MCN</b>	<b>Notes</b>
IVG system		To be supplied	
Holster		CV90-JC339-710	
IVG Mounting Kit with Nut plate, RAM mount	 	65-JB313-1	
Backing plate/ Nut plate only		50-JB290-1	

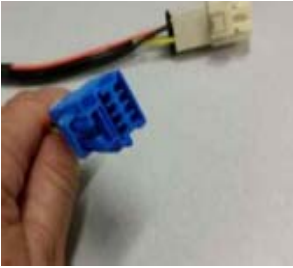
<b>System component</b>	<b>Illustration</b>	<b>MCN</b>	<b>Notes</b>
IVG Mounting Kit: bracket, RAM mount		50-J9978-1	Specifically for Freightliner Columbia or Century
Power I/O cable 6-pin J1587/J1708 only		45-JC365-1A	All trucks 2005 and older. (Transition late 2005-2006.) Separate ignition connection required.
Power/IO cable 9-pin black J1587/ J1708 and J1939 250 kbps		45-JC364-1A	Most 2006 and newer trucks. (Transition late 2005-2006.) Separate ignition connection required.
Volvo/Mack J1587/ J1708 and J1939 250 kbps		45-JC366-1A	2014 and newer Volvo and Mack trucks. Ignition included.

System component	Illustration	MCN	Notes
Hino Power I/O		45-JC375-1A	<p>Early 2011 Hino trucks and late 2011 and newer Hino trucks may not have a telematics connector. Connections will need to be butt spliced. Refer to the Hino Truck Specific Installation Suggestions.</p>
9-Pin Paccar Power I/O		45-JC373-1A	<p>9-pin connector for use with certain Paccar trucks i.e. Kenworth and Peterbilt.</p>
Power I/O cable 9-pin green J1587/J1708 and J1939 500 kbps		45-JE006-1A	<p>9-pin 500 kbps with repeater</p>



## Installation Form



### Installation Work Order Details (IVG)

Company Name: \_\_\_\_\_ Installation Date: \_\_\_\_\_  
 Company Contact: \_\_\_\_\_ Company Phone: \_\_\_\_\_  
 Invoice #: \_\_\_\_\_ Purchase Order #: \_\_\_\_\_ VIN (optional) \_\_\_\_\_  
 Driver Name: \_\_\_\_\_ Truck #: \_\_\_\_\_ Mo/Yr: \_\_\_\_\_ MFG/Model: \_\_\_\_\_  
 Technician #1: \_\_\_\_\_ Technician #2: \_\_\_\_\_  
 Unit Address (DIU S/N): \_\_\_\_\_ Ver. Code \_\_\_\_\_ VTM S/N: \_\_\_\_\_ Ver. Code \_\_\_\_\_  
 Diagnostic connector: 6-PIN \_\_\_\_\_ 9-PIN \_\_\_\_\_ OTIS Firmware: \_\_\_\_\_ Win OS: \_\_\_\_\_  
 PTO Required: Yes \_\_\_ No \_\_\_ PTO Signal: Active High \_\_\_\_\_ Active Low (relay required) \_\_\_\_\_  
 Did you call the Hotline for troubleshooting assistance? Yes \_\_\_ No \_\_\_ Case ID and Name: \_\_\_\_\_

Metrics: DIAG tab: RUN ALL

Put ✓ or X	Test Name	More Info
	Cellular Signal Strength	Signal Strength: _____
	Cellular End to End	Pass or Fail
	CDD Database Sync	
	GPS (From GPS tab)	Mode: _____ Precision: _____ Satellites: _____ / _____
	J1587 Packet Detection	
	J1939 Packet Detection	
	Ignition ON	If green, toggle Ignition OFF and retest to verify you get red X
	Core Data Items (if not GRN, X items to the right using DETAILS Tab)	___Speed ___Distance LTD ___Fuel LTD ___EngineTime ___RPM

**Brightness and Text to Speech Verification:**

Brightness responds to adjustments? Yes \_\_\_ No \_\_\_ TTS volume control works? Yes \_\_\_ No \_\_\_

**Message Verification (send test message with truck number):** Queued \_\_\_ Acknowledged \_\_\_

**Parts Missing at Install:**

Product ID	Description

I find the service rendered and materials installed in connection with the above mentioned work to have been completed in a satisfactory manner.

Driver/Customer Signature: \_\_\_\_\_ Date: \_\_\_\_\_



## **RF Exposure Information (SAR)**

---

This device meets the government's requirements for exposure to radio waves. This device is designed and manufactured to not exceed the emission limits for exposure to radio frequency (RF) energy set by the Federal Communications Commission (FCC) of the United States Government and Industry Canada (IC) of Canada. For optimal device performance and so that human exposure to RF energy does not exceed the FCC and IC guidelines, always follow these instructions and precautions: Orient the device in landscape mode with the cellular antenna (located at the top right corner of the device) away from your body or other objects.

The exposure standard employs a unit of measurement known as the Specific Absorption Rate, or SAR. The SAR limit set by the FCC is 1.6W/kg(1g) for body exposure and 4.0W/kg(10g) for extremity exposure. Tests for SAR are conducted using standard operating positions accepted by the FCC/IC with the EUT transmitting at the specified power level in different channels. Although SAR is determined at the highest certified power level in each frequency band, the actual SAR level of the device while in operation can be well below the maximum value because device adjusts its cellular transmitting power based, in part, on proximity to the wireless network.

In general, the closer you are to a cellular base station, the lower the cellular transmitting power level. The highest SAR value for the device as reported to the FCC is 1.26 W/kg(1g) when placed next to the body and 0.68 W/kg(10g) when exposed to extremities.

The device was tested according to measurement standards and procedures specified in FCC OET Bulletin 65, Supplement C (Edition 01-01) and Canada RSS 102. The FCC/IC has granted an Equipment Authorization for this device with all reported SAR levels evaluated as in compliance with the defined RF exposure guidelines. SAR information on this device is on file with the FCC and can be found under the Display Grant section of [www.fcc.gov/oet/ea/fccid](http://www.fcc.gov/oet/ea/fccid) and searching on FCC ID: 2AE8ZIVG.

