



OKA - 610R

RECEIVER, RF Keyless Entry System

Table of contents

1. Constitution of the Radio Frequency Keyless Entry system Controller for vehicle -----	1
2. User's manual (provisionally) -----	2
3. Block diagram -----	3
4. Specification -----	4
5. Features -----	5
6. Derivatives -----	5

1. Constitution of the Radio Frequency Keyless Entry Controller System for vehicle

The radio frequency keyless entry is a system that it controllers locking and unlocking the door by wireless remote controller. This system consists of two components. The TRANSMITTER is a device that transmits the signal when the button is pressed. The transmission signal consists of several synchronous codes, unique identification code, security code and function code. The RECEIVER is fixed inside the vehicle. It works intermittently to prevent the battery exhaustion. When the receiver detects the synchronous code, it runs continuously to receive the signals completely. After receiving the signal, the receiver decides which operation will be performed. The user can select the following operations by pressing the button of the remote transmitter.

OPERATION	ACTION
LOCK	lock the door
UNLOCK	unlock the door

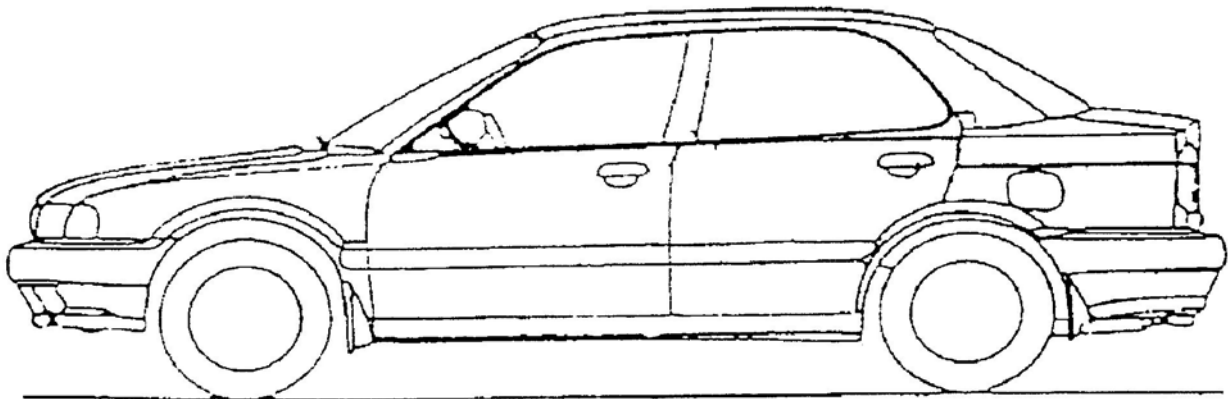

Transmitter
f=307.9MHz

2. User's manual (provisionally)

TRANSMITTER

You can lock and unlock your vehicle with the remote transmitter.

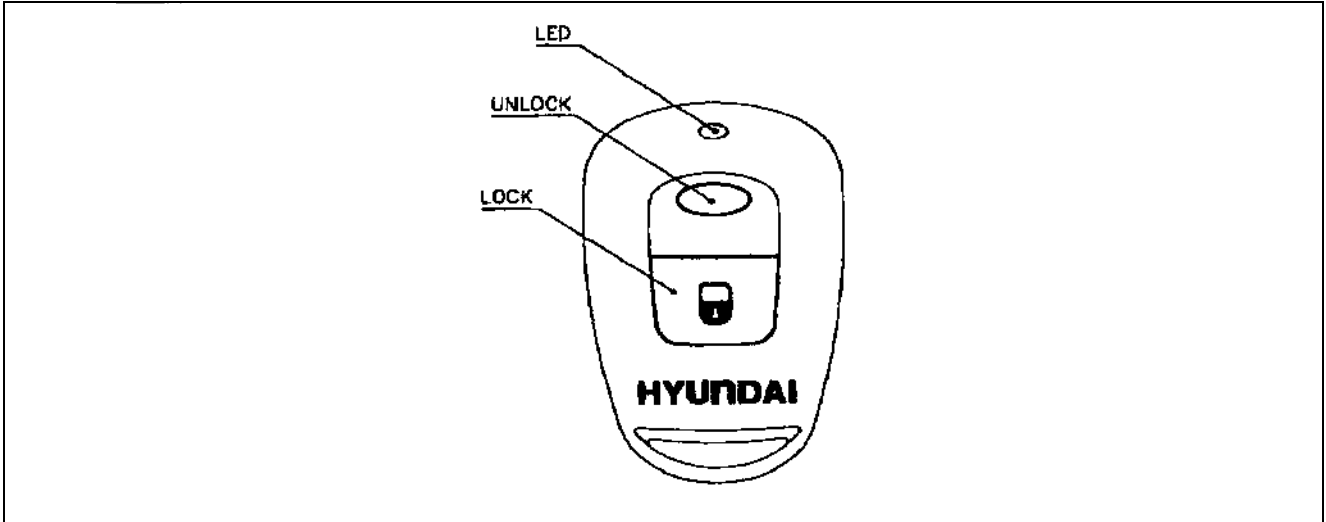

LOCK

When you push the LOCK button, all the doors will lock.

You cannot lock any of the doors with the remote transmitter if any door is open or the key is in the ignition switch.

UNLOCK

When you push the UNLOCK button, all the doors will unlock.

You cannot unlock any of the doors with the remote transmitter if any door is open or the key is in the ignition switch.

3. Block diagram

This is the block diagram concerning to the receiver.

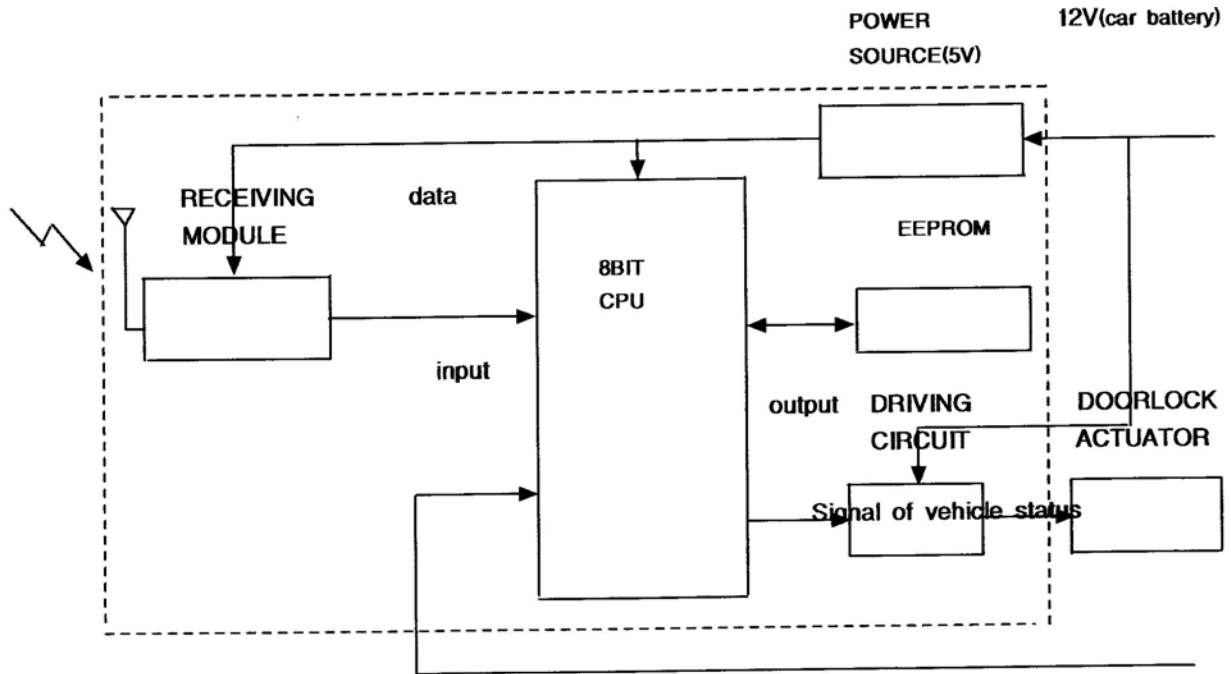

figure 3.1 block diagram of the receiver

4. Specification

4.1 CPU

Type	MB89636(8bit) Manufacturer : FUJITSU
ROM	32K x 8bit
RAM	1K x 8bit
Clock frequency	10MHz
Clock frequency generation	Crystal resonator
Package	64pin QFP

4.2 EEPROM

Type	S-93C46XXX Manufacturer: Seiko. Elec.
Memory	1Kbit
Package	8pin SOP

4.3 RF Receiver Module

Type	WMF-R13 Manufacturer: Mitsumi Elec.
Local clock frequency	318.6MHz
Frequency generation	Crystal resonator
Modulation Scheme	FM (Single Superheterodyne)
Bandwidth	±200KHz
Carrier Detect Sensitivity	11dBuVemf

4.4 Others

Dimension	131mm x 95mm x 40mm
Weigh	287g
Battery	Car Battery(DC 12V)
Operation Voltage, Current	DC12V, 50mA(4mA on standby)
Operation Temperature	-30℃ ~+80℃

5.Features

5.1 Door lock control

The LOCK relay in the receiver drives the door lock actuators to "LOCK"-side when LOCK button of transmitter was pressed. The UNLOCK relay in the receiver drives the door lock actuators to "UNLOCK"-side when UNLOCK button of transmitter was pressed. These facility doesn't work if the key is inserted the key cylinder or the door is open.

5.2 Battery saving

Because of the power source of the receiver is car Battery, it is very important problem to minimize a power consumption. The receiver's CPU works intermittently to prevent the battery exhaustion.

6.Derivatives

OKA-610R is an integrated controller for a car body control, includes the keyless entry receiver. The integrated controller consists of the multiple control functions as follows, centralized door lock, turn-signal lamp, room-lamp, intermitted wiper, power window timer, ignition key illumination, warning buzzer and so on.

INFORMATION TO THE USER

This equipment has been tested and found to comply with the limits for a Class B digital device, pursuant to part 15 of the FCC Rules. These limits are designed to provide reasonable protection against harmful interference in a residential installation. This equipment generates, uses and can radiate radio frequency energy and, if not installed and used in accordance with the instructions, may cause harmful interference to radio communications. However, there is no guarantee that interference will not occur in a particular installation. If this equipment does cause harmful interference to radio or television reception, which can be determined by turning the equipment off and on, the user is encouraged to try to correct the interference by one more of the following measures:

- . Reorient or relocate the receiving antenna.
- . Increase the separation between the equipment and receiver.
- . Connect the equipment into an outlet on a circuit different from that to which the receiver is connected.
- . Consult the dealer or an experienced radio/TV technician for help.

WARNING

Changes or modifications not expressly approved by the manufacturer could void the user's authority to operate the equipment.