

**OMRON
AUTOMOTIVE
ELECTRONICS
KOREA**

OKA-610T

Transmitter, RF Keyless Entry System

Table of contents

1. Constitution of the Radio Frequency Keyless Entry system Controller for vehicle ---	1
2. User's manual (provisionally) -----	2
3. Block diagram -----	3
4. Specification -----	4
5. Features -----	5

1. Constitution of the Radio Frequency Keyless Entry System for vehicle

The radio frequency keyless entry is a system that it controls locking and unlocking the door by wireless remote controller. This system consists of two components. The TRANSMITTER is a device that transmits the signal when the button is pressed. The transmission signal consists of several synchronous codes, unique identification code, security code and function code. The RECEIVER is fixed inside the vehicle. It works intermittently to prevent the battery exhaustion. When the receiver detects the synchronous code, it runs continuously to receive the signals completely. After receiving the signal, the receiver decides which operation will be performed. The user can select the following operations by pressing the button of the remote transmitter.

OPERATION	ACTION
LOCK	lock the door
UNLOCK	unlock the door

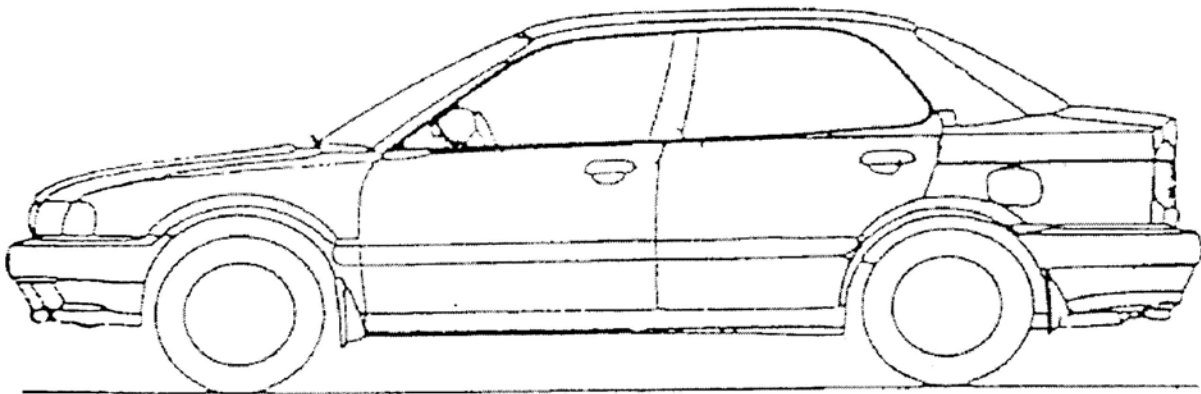

Transmitter
f = 307.9MHz



2. User's manual (provisionally)

REMOTE TRANSMITTER

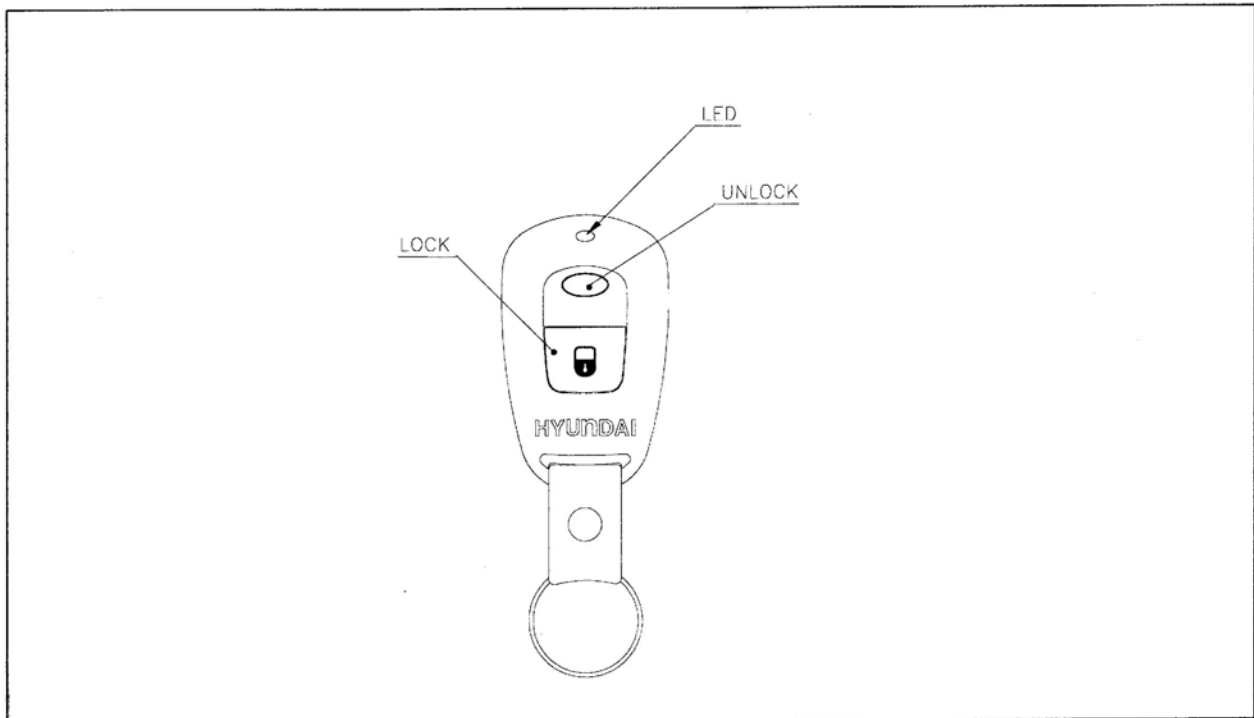

You can lock and unlock your vehicle with the remote transmitter.

LOCK

When you push the **LOCK** button, all the doors will lock.

You cannot lock any of the doors with the remote transmitter if any door is open or the key is in the ignition switch.

UNLOCK

When you push the **UNLOCK** button, all the doors will unlock.

You cannot unlock any of the doors with the remote transmitter if any door is open or the key is in the ignition switch.

3. Block diagram

This is block diagram concerning to the transmitter

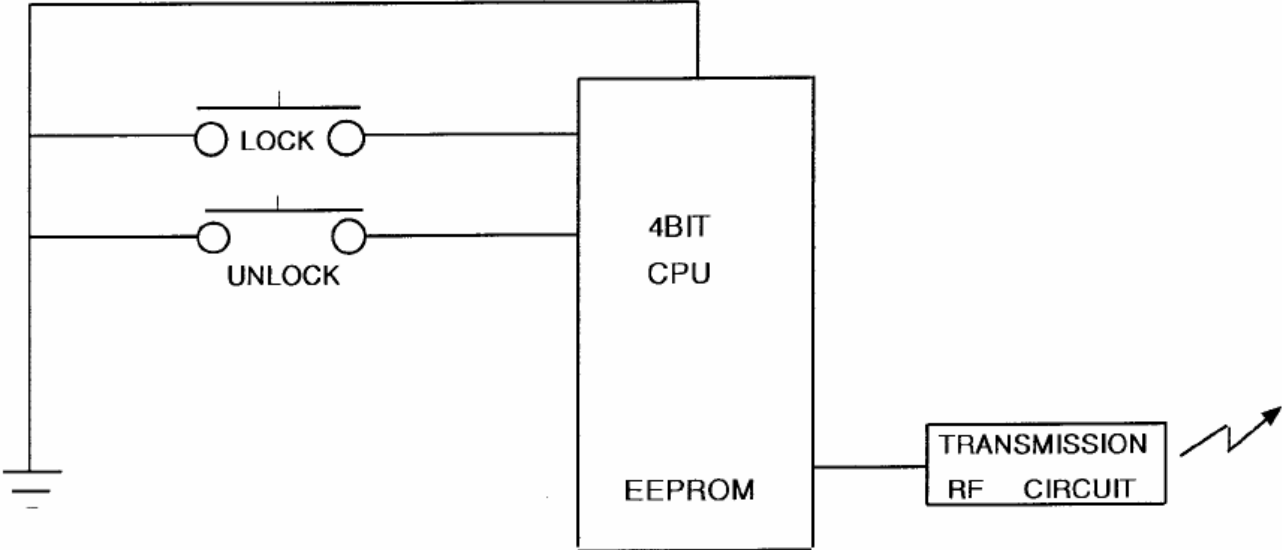

figure 3.1 block diagram of the transmitter

4. Specification

4.1 CPU

Type	uPD754144-xxx(4bit) Manufacturer : NEC Corporation
ROM	4096 x 8bit(4kbytes)
RAM	128 x 4bit
EEPROM	16 x 8bit
Clock frequency	500KHz
Clock frequency generation	CR oscillation
Package	20pin SSOP

4.2 RF block

Carrier frequency	307.9MHz
Frequency generation	SAW resonator
Modulation	FSK
Bit transmission rate	100bps or 500bps
Bandwidth	120KHz
RF output power (field strength)	$\leq 75.6\text{dB}\mu\text{ V/m}$

4.3 Others

Dimension	52.5mm x 33mm x 11mm
Weigh	20g
Battery	Lithium cell (CR2032) Manufacturer: PARASONIC Battery corporation etc.
Operation Voltage	DC3V, 5mA
Operation Temperature	-20 °C ~ +60 °C

5.Features

5.1 Transmission frame

The transmission begins immediately in case of LOCK or UNLOCK button is pressed.

The transmission frame consists of the synchronous frame and the data frame. The synchronous frame has 30 synchronous codes that it will be used for the receiver to wake up. The data frame consists of 24bit length identification code, 16bit security code and function code. 16million different identification codes are available.

The security code is always changed in case of any of the buttons is pressed. The transmission time is typically 600 milliseconds.

5.2 Battery saving

To prevent the battery exhaustion, the micro-computer of the transmitter is usually inactive. When the button will be pressed, the micro-computer wakes up immediately and judges which button is pressing. Then the micro-computer constructs the transmission frame and radiates it from the antenna .After transmitting , the micro-computer switches stand-by mode by itself.

INFORMATION TO THE USER

This equipment has been tested and found to comply with the limits for a Class B digital device, pursuant to part 15 of the FCC Rules. These limits are designed to provide reasonable protection against harmful interference in a residential installation. This equipment generates, uses and can radiate radio frequency energy and, if not installed and used in accordance with the instructions, may cause harmful interference to radio communications. However, there is no guarantee that interference will not occur in a particular installation. If this equipment does cause harmful interference to radio or television reception, which can be determined by turning the equipment off and on, the user is encouraged to try to correct the interference by one more of the following measures:

- . Reorient or relocate the receiving antenna.
- . Increase the separation between the equipment and receiver.
- . Connect the equipment into an outlet on a circuit different from that to which the receiver is connected.
- . Consult the dealer or an experienced radio/TV technician for help.

WARNING

Changes or modifications not expressly approved by the manufacturer could void the user's authority to operate the equipment.

This device complies with Part 15 of the FCC Rules. Operation is subject to the following two conditions: (1) this device may not cause harmful interference, and (2) this device must accept any interference received, including interference that may cause undesired operations.