



---

# OKA-751R

---

Transmitter, RF Keyless Entry System

## Table of contents

1.	Constitution of the Radio Frequency Keyless Entry system Controller for vehicle .....	1
2.	User's manual (provisionally) .....	2
3.	Block diagram .....	3
4.	Specification .....	4
4.1	CPU .....	4
4.2	EEPROM .....	4
4.3	RF Receiver Module .....	4
4.4	Other .....	4
5.	Features .....	5
5.1	Door lock control	
5.2	Battery saving	
6.	Derivatives .....	5
7.	PCB .....	6
7.1	Circuit diagram .....	6
7.2	Parts layout .....	7-10
7.3	Parts list .....	11-12
7.4	Connector .....	13
7.5	Photographs .....	14-15
8.	RF Module .....	16
8.1	Block diagram .....	16
8.2	Circuit diagram .....	17
8.3	Parts Layout .....	18-19
8.4	Part list .....	21
9.	Sticker .....	22
10.	Antenna .....	23

## FCC Operation Statement

This device complies with part 15 of the FCC Rules.

Operation is subject to the following two conditions:

- (1) This device may not cause harmful interference
- (2) This device must accept any interference received, including interference that may cause undesired operation.

## FCC Compliance Statement

This equipment has been tested and found to comply with the limits for a Class B digital device, pursuant to part 15 of the FCC Rules. These limits are designed to provide reasonable protection against harmful interference in a residential installation.

This equipment generates, uses and can radiate radio frequency energy and, if not installed and used in accordance with the instructions, may cause harmful interference to radio communications. However, there is no guarantee that interference will not occur in a particular installation. If this equipment does cause harmful interference to radio or television reception, which can be determined by turning the equipment off and on, the user is encouraged to try to correct the interference by one or more of the following measures:

- Reorient or relocate the receiving antenna.
- Increase the separation between the equipment and receiver.
- Connect the equipment into an outlet on a circuit different from that to which the receiver is connected.
- Consult the dealer or an experienced radio/TV technician for help.

## Caution !

Any changes or modifications to the equipment not expressly approved by the party responsible for compliance could void your authority to operate the equipment.

# 1. Constitution of the Radio Frequency Keyless Entry System for vehicle

The radio frequency keyless entry is a system that it controls locking and unlocking the door and the trunk and the panic by wireless remote controller. This system consists of three components. The TRANSMITTER is a device that transmits the signal when the button is pressed. The transmission signal consists of several synchronous codes, unique identification code, security code and function code and crc code. The RECEIVER is fixed inside the vehicle. It works intermittently to prevent the battery exhaustion. When the receiver detects the synchronous code, it runs continuously to receive the signals completely. After receiving the signal, the receiver decides which operation will be performed.

The user can select the following operations by pressing the button of the remote transmitter.

OPERATION	ACTION
LOCK	lock the door
UNLOCK	unlock the door
TRUNK	open the trunk
PANIC	alarm the horn

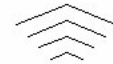
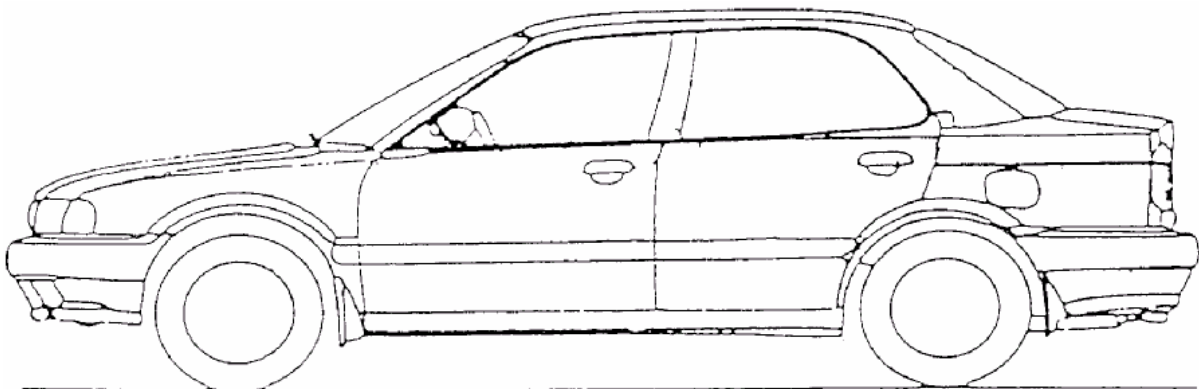

Transmitter  
 $f = 313.85\text{MHz}$



## 2. User's manual (provisionally)

### REMOTE TRANSMITTER



You can lock and unlock your vehicle with the remote transmitter.

#### LOCK

When you push the LOCK button, all the doors will lock.

You cannot lock any of the doors with the remote transmitter if any door is open or the key is in the ignition switch.

#### UNLOCK

When you push the UNLOCK button, all the doors will unlock.

You cannot unlock any of the doors with the remote transmitter if any door is open or the key is in the ignition switch.

#### TRUNK

When you push continuously the TRUNK button during 0.5s, TRUNK will open.

#### PANIC

When you push the PANIC button, horn will alarm.

### 3. Block diagram (Main board)

This is block diagram concerning to the receiver

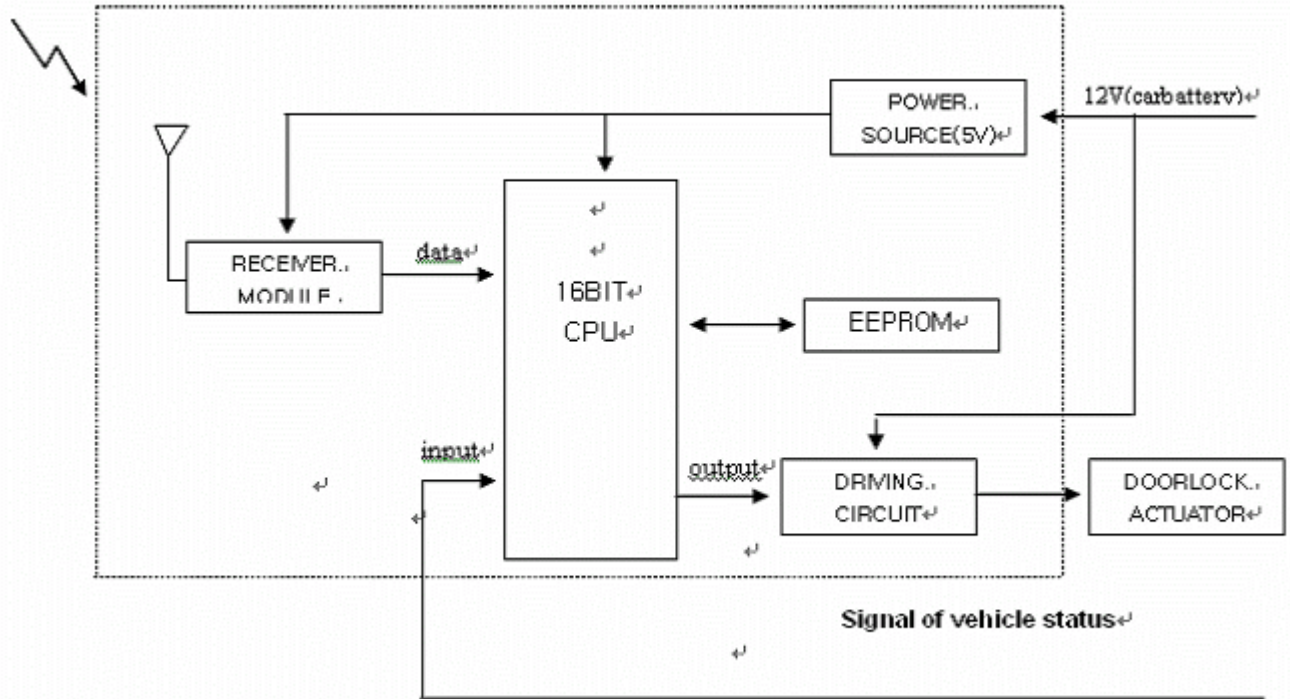

## 4. Specification

### 4.1 CPU

Type	MB90F867(16bit) Manufacturer : FUJITSU
ROM	128KByte
RAM	6KByte
Clock frequency	4MHz
Clock frequency generation	Crystal resonator
Package	100pin QFP

### 4.2 EEPROM

Type	S-93C56XXX Manufacturer: Seiko. Elec
Memory	2Kbit
Package	8pin SOP

### 4.3 RF Receive Module

Type	G8X-21RXIAM Manufacturer: OMRON IIDA
Local clock frequency	313.85MHz
Frequency generation	Crystal resonator
Modulation Scheme	FM(superheterodyne)
Bandwidth	±200 KHz
Carrier Detect Sensitivity	11dBuVemf

### 4.4 Others

Dimension	112mm× 92mm × 36mm
Weigh	324g
Battery	CAR Battery(DC 12V)
Operation Voltage, Current	DC12V,50mA (4mA on standby) -40℃ ~ +80℃

## 5.Features

### 5.1 Door lock control

The LOCK relay in the receiver drives the door lock actuators to "LOCK"-side when LOCK button of transmitter was pressed. The UNLOCK relay in the receiver drives

### 5.2 Battery saving

To prevent the battery exhaustion , the micro-computer of the transmitter is usually inactive. When the button will be pressed, the micro-computer wakes up immediately and judges which button is pressing. Then the micro-computer constructs the transmission frame and radiates it from the antenna .After transmitting, the micro-computer switches stand-by mode by itself.

## 6. Derivat ives

OKA-751R is an integrated controller for a car body control, includes the keyless entry receiver. The integrated. controller consists of the multiple control functions as follows, centralized door lock, turn-signal lamp, room-lamp, intermitted wiper, power window timer, ignition key illumination, warning buzzer and so on.