



# 2 HP Cyclonic Dust Collector *Owner's Manual*



1/07

## *Super* The **DUST** **GORILLA**



\*Models may vary slightly in appearance.

Shown with optional bolt together Angle Iron stand.

## ***Thank You for Choosing an Oneida Air Systems Product!***

OAS manufactures and sells dust collection equipment only. Our qualified technicians and sales staff are available 7:30am - 6:00pm EST Mon. - Thur. and 7:30am - 5:00pm EST Fri. to answer any questions concerning OAS products and dust collection. Call for ductwork design and ductwork quotes, including system pricing and shipping cost.

***Read the entire Owner's Manual before installing or operating system!***

## **Table of Contents**

	<b>Page</b>
I. System Start-Up Information	2
II. Commercial Configurations	3
III. General Specifications & Fan Performance Curves	4
IV. Dimensions	5
V. General Assembly	6
VI. General Assembly Instructions	7
VII. Bracket Assembly	8
VIII. Filter Assembly	9
IX. Filter Maintenance	10
X. Directions for Cleaning External Filter & Clipping Dust Pan	11
XI. Fan / Blower Wiring Diagram	12
XII. Troubleshooting	13
XIII. Fire Hazards - <i>Read Before Installing System</i>	14
XIV. Terms and Conditions	15
XV. Stand Assembly	16
XVI. Accessories	17
XVII. Fan Motor Maintenance	18
XVIII. Optional Remote Controller Diagram	19
XIX. Optional Filter Efficiency Gauge Mounting Instructions	20

# I. System Start-Up Information

1. Read the installation and maintenance instructions as well as the recommended safety practices in this manual.
2. Install Ductwork completely before operating collector:
  - A.) Seal ductwork with silicone sealant or duct tape.
  - B.) Have Dust Bin in place and sealed.
3. Have licensed electrician wire Fan / Blower according to wire diagram on pg. 12 in this owner's manual.
4. Have licensed electrician check current draw on motor with all gates open. Current draw should not exceed maximum motor amperage. (OAS is not responsible for damage to motors caused by improper installation, wiring or failure to follow these directions.)

## Caution

*The Direct Drive Fan / Blower makes the system top heavy!  
Use extreme care when setting the unit up!*

## Warning

*Do not operate Fan / Blower unless Cyclone and Dust Bin  
are in place. Motor will over heat!*

## Warning

*Check amperage draw during operation with (2) open 5" dia.  
blastgates (or smaller). Make certain amperage is not outside  
operating limit indicated on motor plate!*

## Warning

*If amperage is too high - shut down immediately!  
(See troubleshooting section.)*

# II. 2hp Dust Gorilla Configurations

## Caution:

If exhaust air is vented outside you must provide make up / return air.  
Flue gases (carbon monoxide) can be drawn into the shop from furnaces, water heaters or other appliances.

## 1. External Cartridge Filter - Silencer Included with Filter

### Cartridge Filter Media

- 1 Pleated Spun-Bonded Cartridge Filter 39" / 95 Sq. Ft. Accredited, independent lab tested. Bathed in teflon-like coating for easy dust release. Captures 99.9% of Test Material from 0.2 - 2 microns.



1. External Cartridge Filter

Silencer included w/ Filter

Shown with optional Angle Iron Stand.

## 2hp and Under Systems

13" Diameter Filter

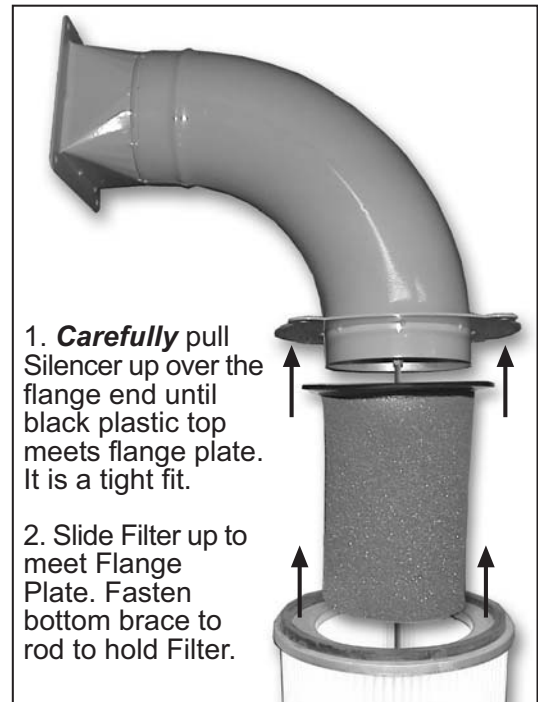

Follow Pg. 9 in Owner's Manual to Complete Installation.

# III. General Specifications & Fan Performance Curves

	Height without Dust Bin	Cyclone Diameter	Inlet Diameter	Weight without Dust Bin	TEFC* Motors
<b>2.0 hp</b>	63"	21"	7"	Approx. Wt. 122 lbs. w/o drum or filter	Class F 115/230v 23/11.5 amps 1.15 Service Factor

- Sleeve kit adds 7" (4" is minimum)
  - 35 gal. bin is 22" dia. x 22.5" h / 55 gal. bin is 22" dia. x 35.5" h
  - Several Filter Options Available- Galvanized steel construction
  - The collector can be hung on the wall, from the ceiling, or free standing support using the 10 ga. angle iron ring at the top of the cone.
- (See assembly instructions)

## 2hp Super Dust Gorilla System

- ▶ 1422 CFM @ 2.3" SP w/c w/o filter
- ▶ Industrial Baldor TEFC 2hp motor\*
  - 115/230v - 23/11.5 amps / 1.15 Service Factor
- ▶ Full 16 gauge galvanized cyclone & 11 ga. fan housing
- ▶ 7" dia. inlet / 8" rectangular outlet
- ▶ 14.25" dia. x 4" wide cast aluminum fan wheel  
back inclined non-sparking, non-ferrous dynamic, two-planed balanced to ISO 6.3 specifications.
- ▶ Sound 78 - 79dB @ 10' with Built-in Silencer and Filter
- ▶ 95 Sq. Ft. Filter Media / Spun-Bonded

\* Note: Motor Starter supplied with system is for 220v only.

Static pressure and volume together determine a fan's performance. Several factors, such as layout of ductwork and diameter of openings, can affect a fan's performance.

### 2hp Super Dust Gorilla CFM vs. SP Curve\*

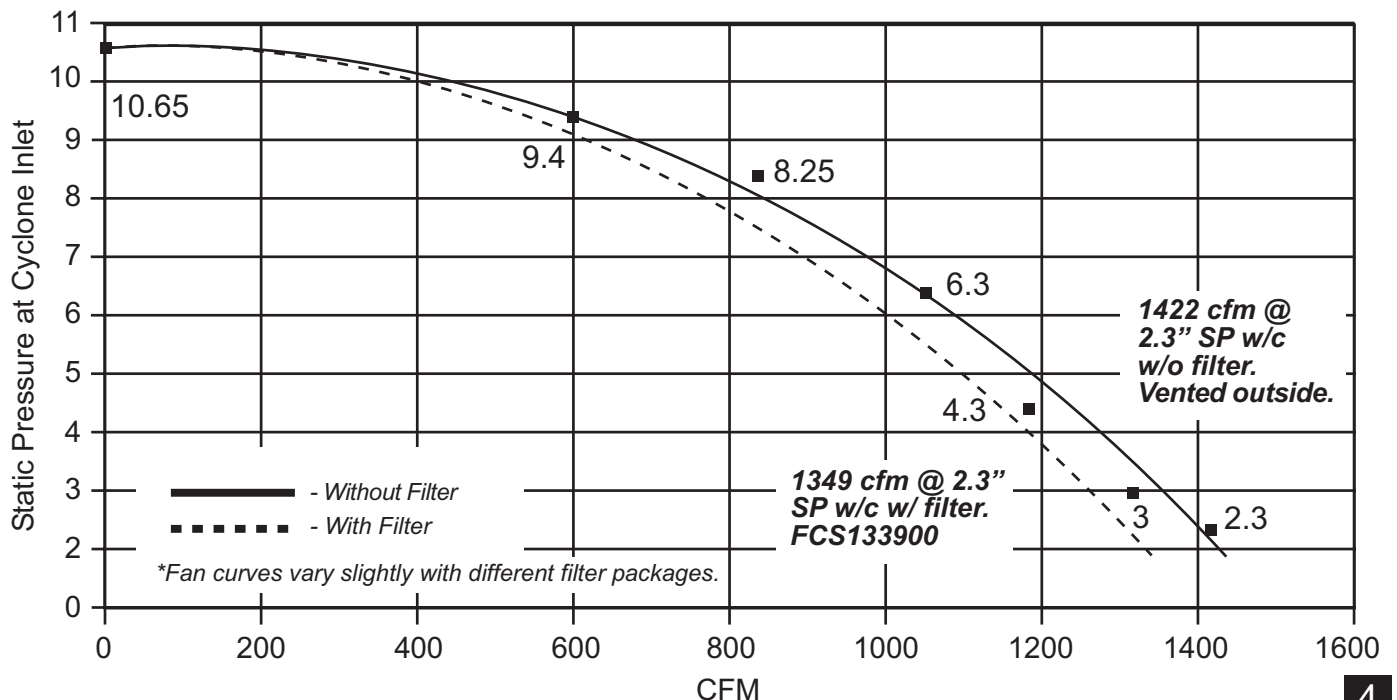

# IV. Dimensions

## For Minimum Mounting Heights w/ 39" Filter.

\*Dimensions subject to slight variation in manufacturing.

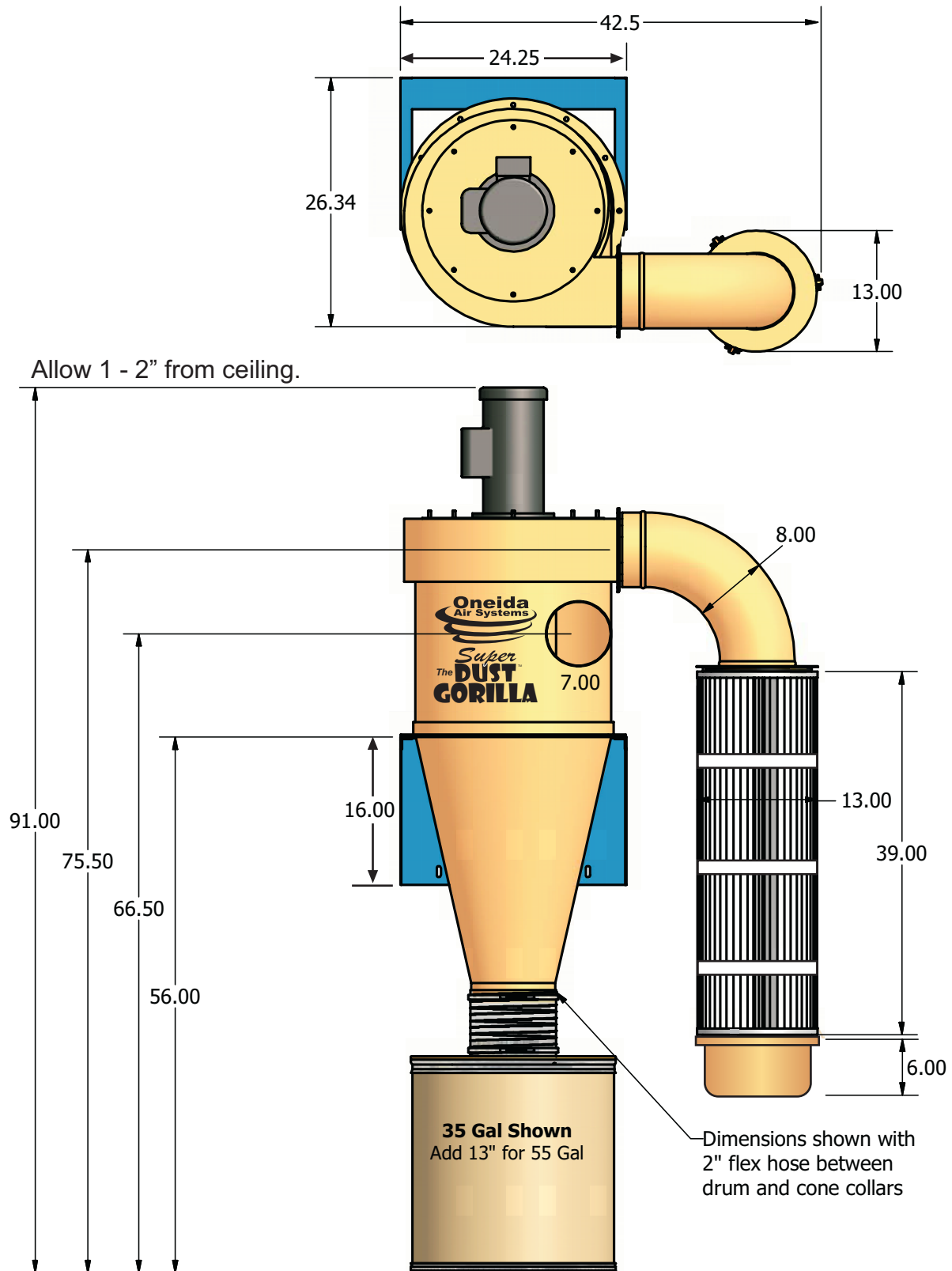

# V. General Assembly XGK020105

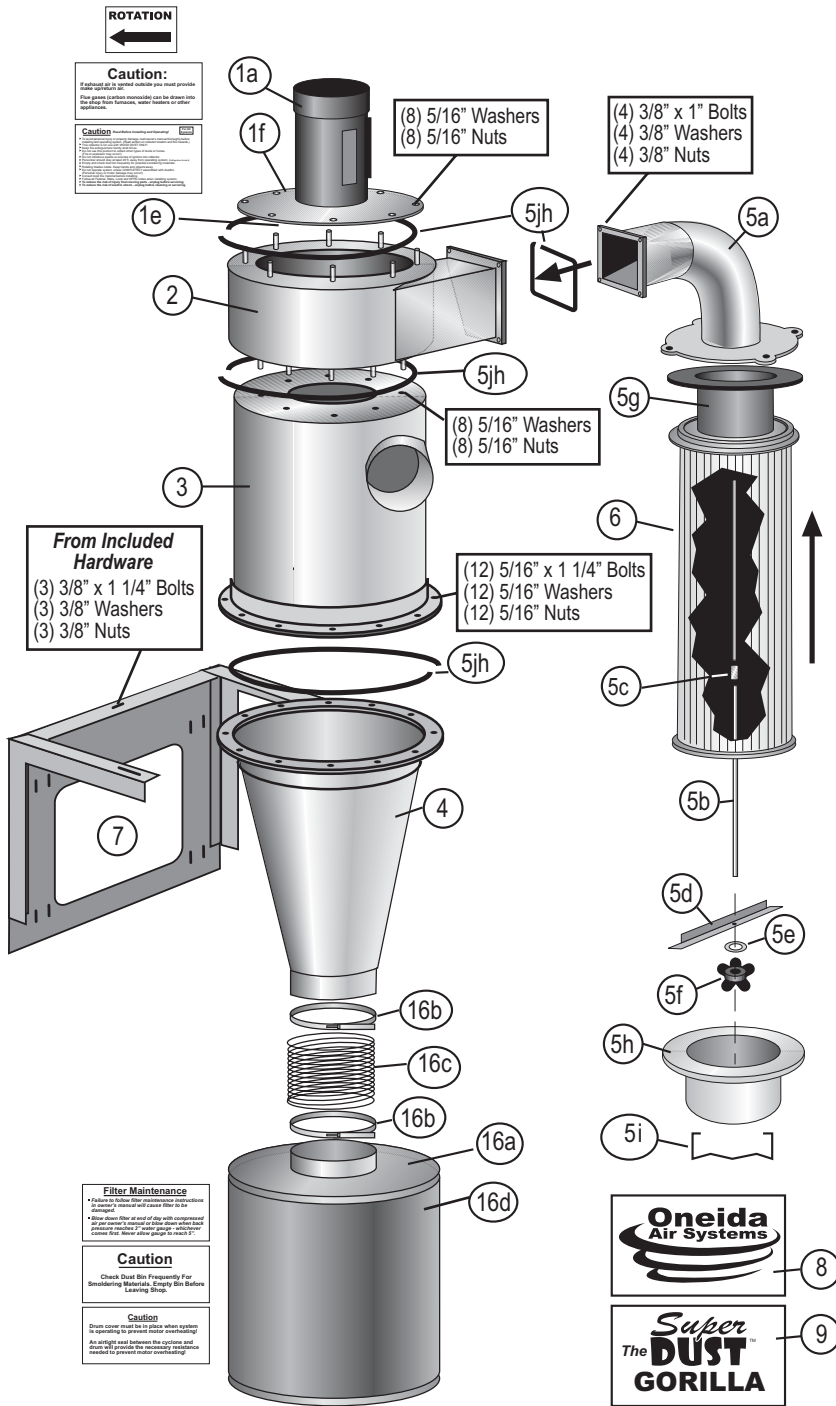

1. Motor Assembly - BXI002105
  - 1a. 2 hp Motor - BMZ020105
  - 1b. Magnetic Starter w/ Remote Option - AMR221114
  - 1c. Cord Connector - WCC025038
  - 1d. Cord Connector Lock Nut - WCN120000
  - 1e. Fan Wheel - BWX142578
  - 1f. Motor Plate - RMP002105
2. Fan Housing - BHX030005
3. Cyclone Barrel - SXI002105
4. Cyclone Cone - SCX002105
5. Plenum 9" Kit - GXF015339
  - 5a. Plenum Elbow 8" Assembly - FPX015339
  - 5b. Filter Support Rod (2) - YSS000200
  - 5c. 5/16" Connector 18 x 7/8" - VRH051618 (1)
  - 5d. Filter Support Brace - RBX000000
  - 5e. Washer - AFW170000
  - 5f. Thumb Nut - AFT000001
  - 5g. Internal Silencer (Pat. Pend.) - BSC130000
- 5h. Dust Pan - RFG130805
- 5i. Dust Clips (3) - AFC000000
- 5j. Hardware Kit - AHX000000
  - a. (3) 3/8 x 1 1/4" Bolts - AFS015700
  - b. (14) 3/8" Washers - AFW190000
  - c. (7) 3/8" Wiz Nuts - AFT00004
  - d. (4) 3/8" x 1" Bolts - AFS015100
  - e. (12) 5/16" x 1" Bolts Prewelded - AFB155190
  - f. (24) 5/16" Washers - AFW180000
  - g. (28) 5/16" Nuts AFT155175
  - h. Gasket (25") RAZ000000
- 5k. Owner's Manual - ZBM000013
6. Filter 13" dia. x 39" L - FCS133995
7. Wall Bracket - SMS300021
8. Decal - (1) Oneida Logo - ZBC000015
9. Decal - (1) Gorilla Logo - ZBC990020
10. Rotation Label - ZBC000029
11. Caution / Exhaust Label - ZBS000004
12. General Caution Label - ZBS000001
13. Filter Maintenance Label - ZBS000007
14. Caution / Check Frequently Label - ZBS000006
15. Caution / Drum Cover Label - ZBS000005
16. Gal. Fiber Drum Kit (Standard) - SDK350901
  - 16a. Drum Lid w/ 9" Ring - SDX000900
  - 16b. Hose Clamp (2) - ACB120000
  - 16c. Flex Hose (9") - DHF090000
  - 16d. 35 Gal. Fiber Drum - SDS350000
17. 55 Gal. Fiber Drum Kit - SDK550901
  - 17a. Drum Lid w/ 9" Ring - SDX000900
  - 17b. Hose Clamps (2) - ACB120000
  - 17c. Flex Hose (9") - DHF090000
  - 17d. 55 Gal. Fiber Drum - SDS550000
18. 55 Gal. Steel Drum Kit - SEK550901
  - 18a. Drum Lid w/ 9" Ring - SEX550900
  - 18b. Hose Clamps (2) - ACB120000
  - 18c. Flex Hose (9") - DHF090000
  - 18d. 55 Gal. Steel Drum - SES550000

## Optional Angle Iron Stand

- 34a. Optional 35 gal. Angle Iron Stand - STG021035
  1. Uprights - SXX000056 (4)
  2. Braces - SXX000021 (4 / SXX000023 (3)
  3. Feet - STX002001 (4)
- 34b. Optional 55 gal. Angle Iron Stand - STG021055
  1. Uprights - SXX000068 (4)
  2. Braces - SXX000021 (7)
  3. Feet - STX002001 (4)

## Stand - Hardware Kit - AHX021023

- A. (32) AFB155190 - 5/16" Bolts
- B. (32) AFT155175 - 5/16" Wiz Nuts
- C. (64) AFW180000 - 5/16" Flat Washers

# VI. General Assembly Instructions

Do NOT use hook on motor to lift unit.

There are essentially three ways to assemble your collector and to attach it to the bracket. The way that is right for you should be determined by expertise and manpower available. When the units are all assembled they are very heavy and top weighted. All of this should be taken into account before deciding on the method best suited for you.

With all assemblies, make sure rectangular air outlet is oriented on Fan/Blower housing as you are looking down as in Fig. 1A or facing it as shown in diagrams. This is very important. Then you can rotate housing to whatever bolt position is best for your shop.

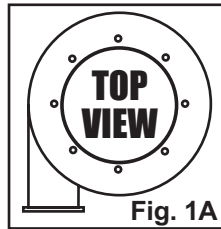

Before you start, make sure you have cut and placed the provided gasket material on top and bottom of the Fan/Blower housing and the Cone as shown in the diagrams. Then determine which direction you want your filter to hang and which direction your ductwork will enter the collector.

### Method #1 -

Bolt Fan/Blower housing to Cyclone barrel. Then bolt Motor and Plate to Fan/Blower housing. Carefully lay unit on its side and then bolt cone to barrel. Lift entire unit up onto wall bracket. Unit is extremely heavy and top weighted, be advised!

### Method #2 -

Bolt Fan/Blower housing to Cyclone barrel. Then bolt Motor and Plate to Fan/Blower housing. Put Cone up on Wall Bracket and orient holes. Lift assembled unit onto cone making sure proper holes are lined up. Bolt unit to bracket, then finish bolting barrel to cone.

### Method #3 -

Bolt Fan/Blower housing to Cyclone barrel. Put Cone up on Wall Bracket and orient holes. Lift assembled unit onto cone making sure proper holes are lined up. Bolt unit to bracket, then finish bolting barrel to cone. Lift Motor & Plate onto Fan/Blower housing and bolt together in proper direction.

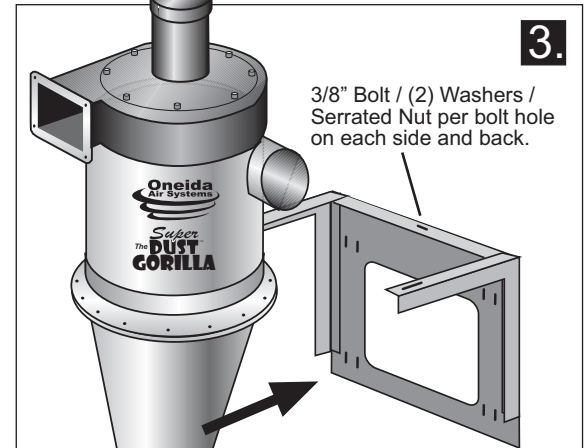
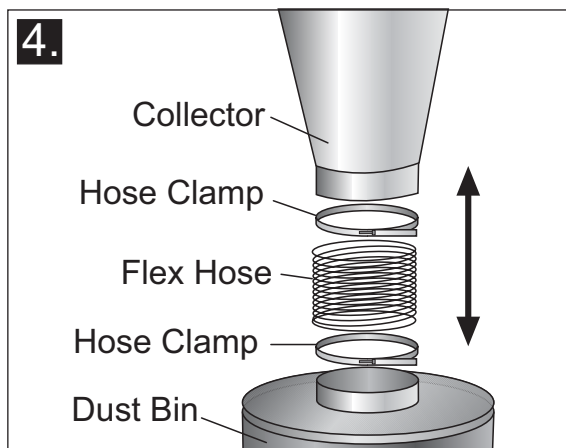
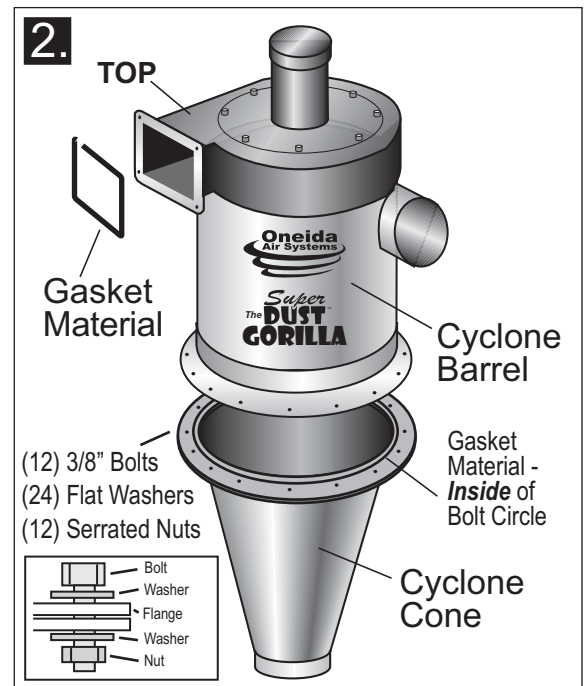
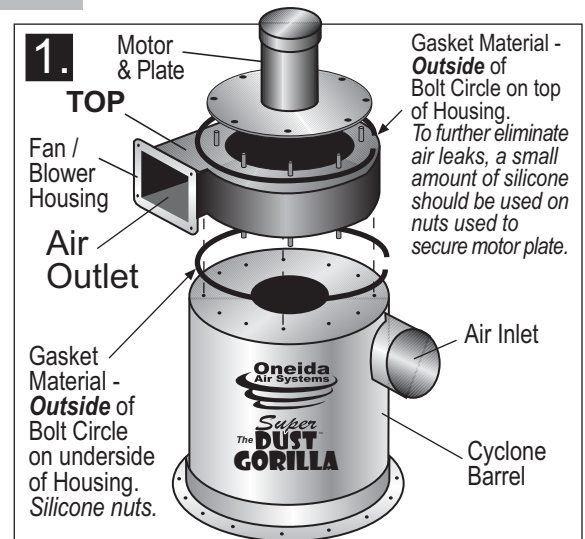

Note: For cyclonic pre-separation there must be an air tight seal between cyclone and dust container. Dust bin must be located vertically under cyclone, material drops down by gravity.



# VII. Bracket Assembly

1. You must determine the direction the fan outlet will point to proceed with this mounting assembly. The collector will seem quieter if the outlet is aimed away from the area people tend to work. Slots in the brackets are .406" x 1.00"

Note: Bolts included to mount bracket to collector. Hardware NOT included to mount to wall.

2. Hold bracket against wall with top of plate at 56". Mark where mounting holes fall. Mount wall bracket. For wall mounting, the bolt centers on the brackets are at 16" to accommodate most wall stud spacing. See Fig. 1 & 2. Use a Level to ensure straightness.

3. Attach bracket to wall with lag screws, concrete anchors, or other suitable hardware. See Fig. 2 & 3. Note: When installing the brackets on a concrete wall, mount 2 x 4's between wall and brackets to stabilize and dampen vibration.

4. Position Angle Ring around top of cone over bracket. Line up one hole in Ring with hole in each bracket at desired rotation of outlet. If rotation you desire does not correspond to an existing hole in Angle Ring, drill new ones. Use three 3/8" bolts (included) with washers & lock washers to secure the fan. See Fig. 4.

5. Attach tightly with bolts. See Fig. 4.

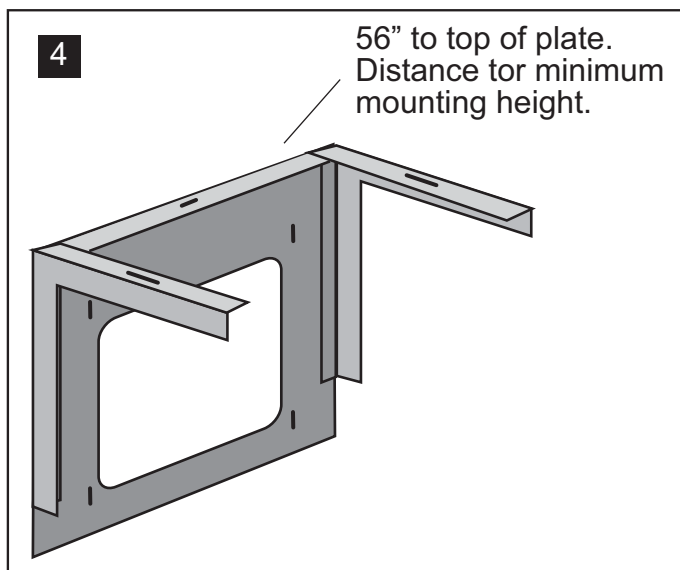
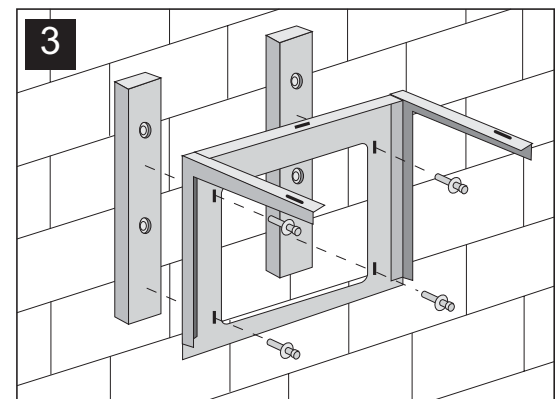
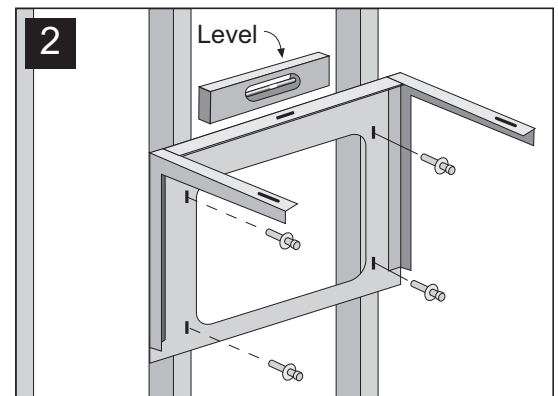
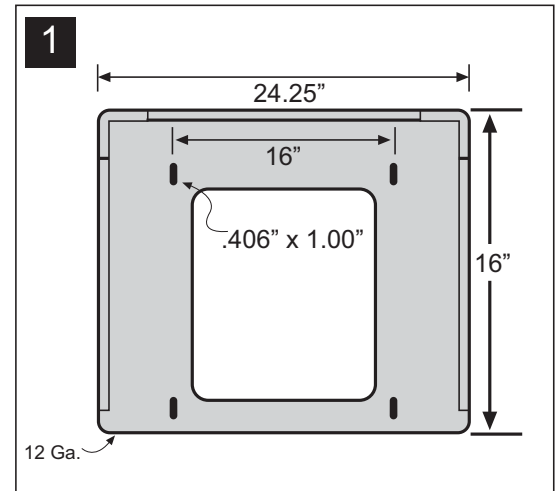

**Note: Please do not install an Oneida Dust Collection System alone. Competent assistance is advisable. Units are heavy!**

# VIII. Filter Assembly

## External 39" Filter Assembly

\*Silencer Included.

1. Attach cartridge with hardware provided making sure gasket is attached. See Fig. 1
2. If Filter requires additional support. Use the plate at the top of the filter to support the filter assembly.

Note: If filter cartridge is located away from the cyclone and motor, additional square-to-round connectors and pipe can be purchased.

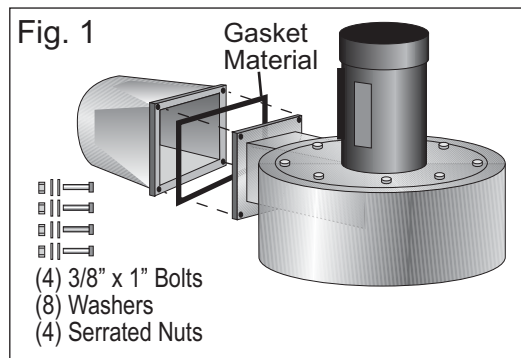

Before attaching filter, you must first **carefully** pull foam silencer on to end of plenum, pushing black plastic end against flange plate. It is a tight fit.

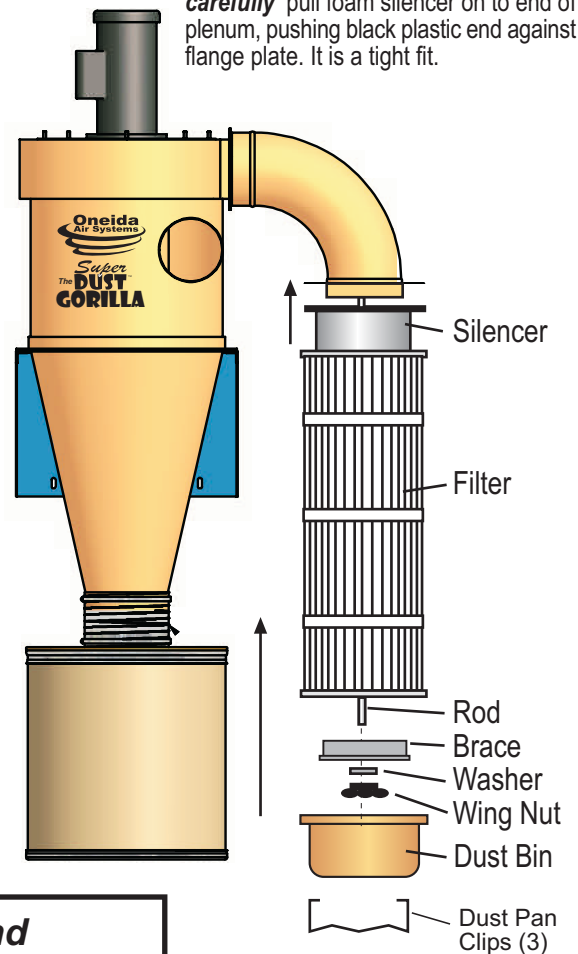

**For Filter cleaning instructions and Dust Pan clipping instructions, see pg. 11.**

## No Filter Assembly

1. Exhaust air to exterior of building. Mount directly at the hole in exterior wall or use a square-to-round transition and ductwork to vent air to exterior.

Option -

\* Exhaust Diverter - Can be used either up or down

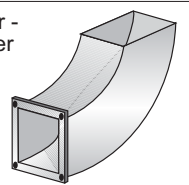

\* Only usable on No Filter.

Note: Do not return exhaust air to the shop unless filter media is added.

### Caution:

If exhaust air is vented outside you must provide make up / return air. Flue gases (carbon monoxide) can be drawn into the shop from furnaces, water heaters or other appliances.

**Caution: Rotating blades! Keep hands clear. Keep people away from exhaust.**

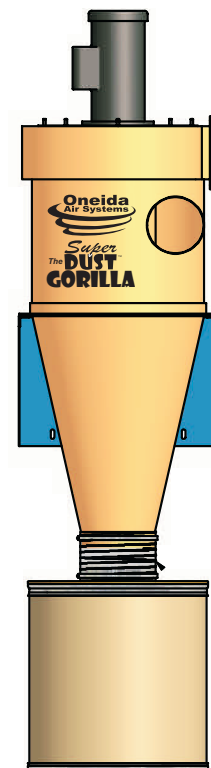

# IX. Filter Maintenance

## External Filter Cartridge Cleaning Intervals

When unit is turned off, use compressed air to blow dust off from exterior of filter. Hold nozzle at least 8" away from filter pleats\*. Do not remove bottom dust pan before or during the blow-off process! Let dust settle into dust pan. Unclip and dump out dust. Filter removal is not required.

\* **WARNING:** A close, direct blast with the compressed air nozzle too close to filter, may damage filter media. Always wear safety glasses while blowing off filter.

**Caution: Fine dust collected in filter is hazardous to your health! Do not breathe!**

## Fan / Blower & Cyclone Outside Placement

Fan / Blower has a TEFC - Totally Enclosed Fan Cooled motor.  
Note: Use steel drum when placed outside.

### Before Operation:

Mount system and connect cyclone and dust bin. Make sure dust bin is in place before turning on the dust collector.

**Do not operate Fan / Blower unless Cyclone and Dust Bin are in place! Motor will overheat!**

### Electrical Wiring:

Make sure power source matches wire voltage configurations on motor.

Prior to connecting to the power line, check motor plate for proper voltage and rotation connection. Wire for counter-clockwise rotation. Fan wheel must rotate counter-clockwise if looking down on fan housing.  
Note: If fan is wired incorrectly and fan is rotating backwards, poor suction and airflow will result. See Wire Diagrams on motor plate.

Use 12 gauge cord for the fan / blowers.

### Lubrication:

See page 18 for instructions.



Shown with optional Angle Iron Stand.

**Caution: Rotating Fan Blades! Keep objects clear of outlet.**

# X. Directions for Cleaning External Filter

All steps should be done with a dust mask and eye protection.

The External Filter can be cleaned using the following methods:

## 1. Compressed air from outside.

Blast air along pleats of the filter at about a 20° angle. Blast air out and away from you or anyone in the general area. Keep air nozzle at least 6" from filter. Closer blasts may damage filter material.

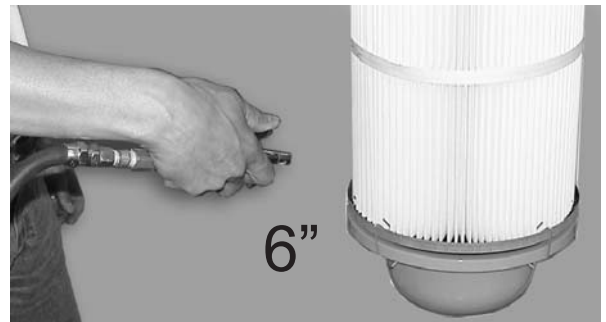

## 2. Empty Dust Bin.

Wait a few minutes for internal dust to settle then unclip and carefully empty dust bin.



## 3. Rinse with water. (Optional)

Keep nozzle at least 6" from filter and keep your pressure down. Closer blasts may damage filter material. Rinse off *INSIDE* of filter. Let filter dry completely before reuse or keep a spare filter on hand.



## Clipping Filter Dust Pan

Position bottom of "U" on top of clip between filter pleats, then push bottom of clip underneath the rim of the dust pan. Space the three clips equally around the dust pan, making sure the pan is even with filter bottom and tightly sealed.

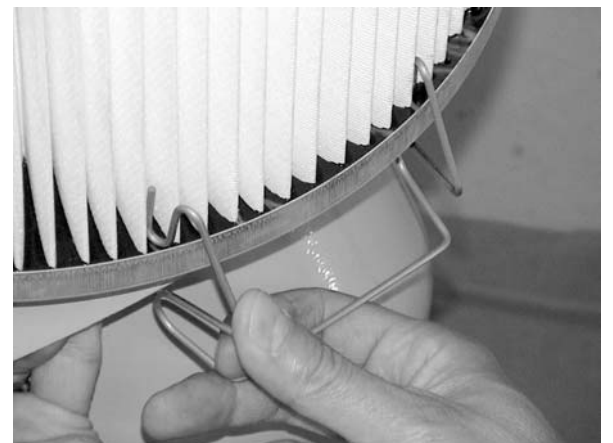
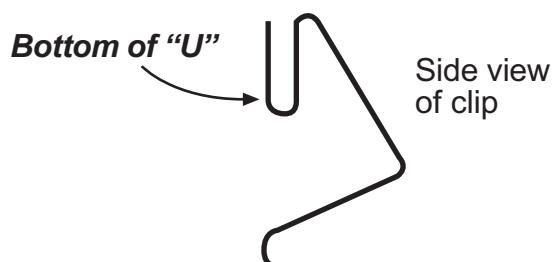

# XI. Wiring Diagram for Magnetic Starter (220v, 1 Ø\*\* )\*

*Always use a licensed, professional electrician.*

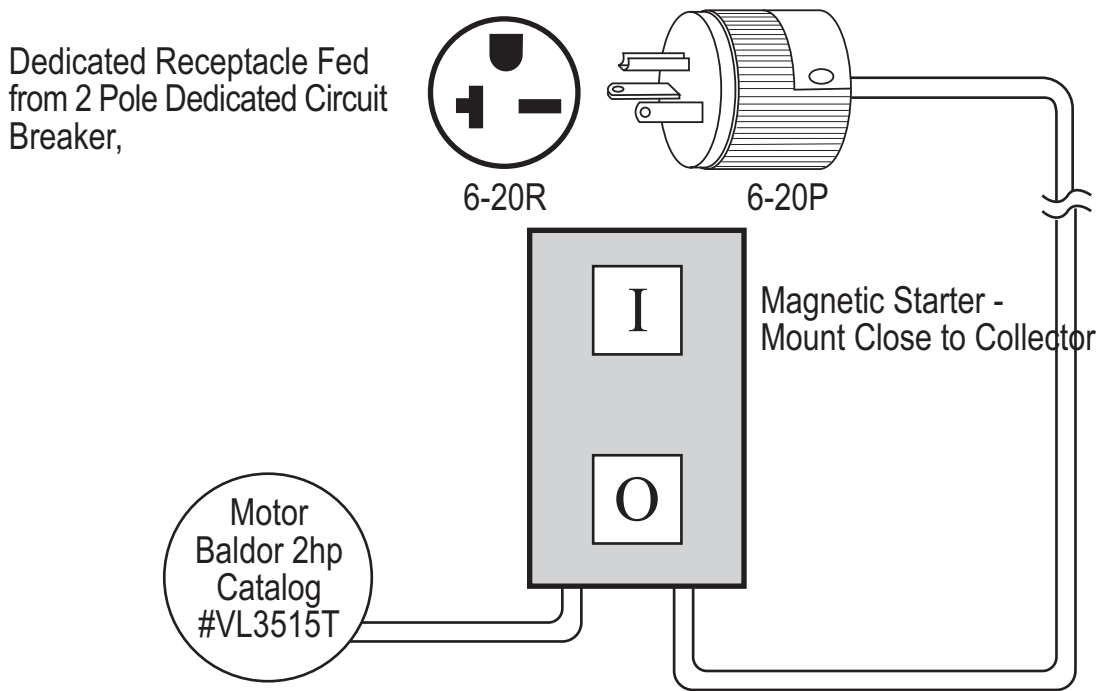

6' Long Type SJT  
14 AWG Power Cord

\* Note: Motor Starter supplied with system is for 220v only.

Note: This Dust Collector is pre-wired at the factory and need only be plugged into a NEMA 6020R dedicated electrical receptacle. 3hp single phase only.

Optional Remote Controller diagram pg. 19

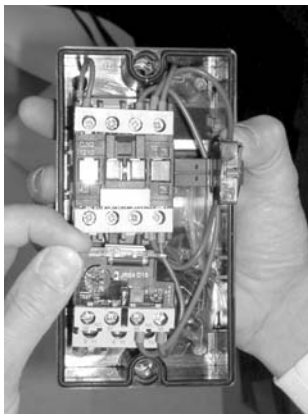

Open access cover on the Overload.

**Note: Overload must be set or nuisance tripping may occur.**



Set the overload amperage dial for the SFA\* amperage of your motor. The SFA\* value can be found below:  
SFA = 12.1  
(FLA ± 11.5)

\*SFA - Service Factor Amperage  
\*FLA - Full Load Amperage

**\*Starter will not operate at any other voltages.**

**\*\*Starter is shown configured for 1Ø but can also be used for 2hp, 3Ø motors.**

## **XII. Troubleshooting**

**Unplug unit before servicing or cleaning.**

### ***Motor Overheating***

*The motor's internal circuit breaker will trip if the motor is overheating.*

**Caused By:**

Air leaks between the collector and dust bin

- The lid of the dust bin must be in place and sealed when operating the dust collector.
- Make sure flex hose is not torn and the hose clamps are tight.
- Check drum lid; cover should have a foam seal and be well seated.
- Check for holes or leaks in the dust bin barrel.

Motor not properly wired. Check wire connections. (See wire diagram )

- Check motor rotation - See wire diagram

Check breaker box. Make sure power supply is correct for motor.

### ***Poor Dust Pick-Up at Woodworking Machines***

**Caused By:**

***Improper motor rotation - Running backwards will reduce suction by 30%.***

Check length of duct runs and duct diameters compared to ductwork design guideline.

Make sure all ductwork is sealed. Large air losses will occur even through small cracks in the ductwork. Use silicone, duct tape or duct mastic compound as a sealant.

Check for air leaks between collector and dust bin.

Close all unused blast gates at your woodworking machines.

Examine hood design for weaknesses according to the ductwork guide.

Check for a restricted pipe, too small a hood port or too small a branch line. See branch line diameter chart in ductwork guide.

Be sure that your filter is clean. See filter cleaning directions.

### ***Filter Clogging***

**Caused By:**

Large chips clogging the filter

- Check for a leak in the dust bin, flex coupling or lid. Check for split or torn flex coupling. (See also: Motor Overheating Section above)
- Make sure dust bin has not over filled. Dust bin should be emptied before the dust reaches top of the container.
- Interruption of air flow, such as vacuuming chips with a flex hose connection, will increase filter maintenance.

Fine dust clogging the filter

- Air flow to the collector may be restricted. The collector needs the equivalent of at least a 4" diameter cross-section open to allow adequate air volume and speed for pre-separation in the cyclone stage of the collector. If you are using a woodworking machine with only one 2" diameter dust port, partially open another blast gate to compensate.
- Check for excessive elbows at cyclone inlet as explained in the mounting collector section.
- Heavy sanding with a drum sander or fine grit paper will cause the pleated filter media to blind sooner than with larger size dust. Clean filter more often with compressed air.

**Note: If you continue to experience difficulty with your collector call Oneida Air Systems at 1-800-732-4065 for assistance.**

# **XIII. Fire Hazards - Read Before Installing and Operating**

## **Oneida Collectors are designed for WOOD DUST only!!**

Wood shaping and cutting processes generate wood chips, shavings, and dust. These materials are considered combustible. Air borne wood dust below 420 microns in size (.017 of an inch) in certain concentration ranges when ignited can deflagrate (burn quickly).

An ignition source such as a spark, or ember, can ignite a dust mixture resulting in an expanding flame front, which can cause an explosion if tightly contained. A disturbance that raises a cloud of accumulated fine dust can raise additional dust clouds, which can cause a series of explosions that can level an entire building. *Until this type of fire has been witnessed, it is difficult to believe the devastation. This type of fire is rare but worth safeguarding against.*

The best way to avoid a wood shop fire is to keep the shop clean. A shop ankle deep in dust with layers of fine dust everywhere is an accident waiting to happen. A good dust collection system reduces overall fire hazards but also adds new concerns. A fire hazard is still present. Combustible material is now in the dust collector and storage container.

*The following points are worth heeding:*

- It is the buyer's responsibility to follow all applicable federal, state, local, OSHA, NFPA, or authorities having jurisdiction codes and regulations when installing and operating this dust collector.
- Fire Marshalls may want the unit located outside of the building. If the collector is located inside the facility, controls such as spark detection, suppression, or explosion venting may be required.
- Most local jurisdictions consult or adopt NFPA ( National Fire Protection Agency) codes. However, other codes may apply. Local codes may vary from jurisdiction to jurisdiction.
- NFPA 664 Code book, "Standard for the Prevention of Fires and Explosions in Wood Processing and Woodworking Facilities", applies to woodworking operations that occupy areas of more than 5,000 sq. ft. or to areas where dust producing equipment requires an aggregate dust collection flow rate of more than 1500 cfm (Cubic Feet per Minute). This exempts some small operators from the NFPA code 664, but other codes may apply in your jurisdiction. Consult your local Fire Marshall for help. Additional information can be found in NFPA Code Book 664.

*The customer assumes the responsibility for contacting their insurance underwriter with regard to specific application requirements of explosion venting or if additional fire protection and safety equipment may be required.*

- **Do not use this product to collect other types of dust or flammable vapors.**
- **Fire or explosion may occur!**
  - Never collect sparks from a bench grinder into a wood dust collector.
  - Never introduce sparks or sources of ignition into the dust collector.
  - Personnel should keep at least 20 feet away from unit.
  - Check dust bin frequently and before leaving the shop for smoldering material.
- Keep portable Fire Extinguishers handy.
  - The ABC type (dry chemical) is generally a good choice for small wood shops.
  - Additional information on portable extinguishers can be found in NFPA 10 (Standard for Portable Fire Extinguishers).
- Be especially careful with sanding units. They can produce concentrations of dust in the combustible range. Make certain enough air volume is at the suction point to capture all the particulate generated.
  - This high air volume will dilute the mixture below the lower limit of flammability. Be careful not to generate sparks into the sanding dust.
  - Empty dust bin and clean filter often, especially when sanding.
  - Don't overload woodworking equipment, especially sanders. Excessive frictional heat can spontaneously ignite dust.
- Sparks can be generated in several ways:
  - High-speed sanders and abrasive planers may strike foreign material
  - Saws and edgers may strike foreign material and create a red hot metal fragment.
  - Knots in hardwood can create frictional sparks.
  - Tramp metal when drawn into the collector can spark against ductwork.
  - Check wood stock for old nails and screws which can create red hot metal fragments.
- Avoid using excessively large wood waste storage bins.
- Always check storage bins for smoldering material before leaving for the day.
- Electrically ground all equipment and ducting. Static sparks can ignite wood dust. (Avoid using PVC drainpipe)
- Don't allow accumulation of layers of fine dust on horizontal surfaces. (Especially overhead lights, electrical boxes, and fuse panels which can ignite dust)

**Unplug unit before servicing or cleaning.**

# XIV. Terms and Conditions

---

## ***Checking in Order***

Please look over the shipped order very carefully in the presence of the delivery person for damage or incomplete shipment before signing the delivery receipt. Please note any tears or irregularities in shipping packaging, however slight, on the shipping delivery receipt. This could be an indication of extensive concealed damage. The shipping company will not take responsibility if the damage is not noted on the delivery receipt. In the event of shipping damage, call O.A.S. immediately so we can expedite replacements. Please check in all parts within 3 days from receiving order. Notify O.A.S. immediately of any missing or incorrect parts. O.A.S. does not accept any claims for damage or shortage after 3 days from date of delivery.

## ***Limited Warranty***

Oneida Air Systems warrants products it manufactures for a period of 2 years to the original purchaser from the date of purchase. Items not manufactured by O.A.S. are limited to their own manufacturer's warranties. This warranty does not apply to defects due directly or indirectly to misuse, negligence, accidents, abuse, repairs, or alterations or lack of maintenance. This is Oneida Air Systems sole written warranty and any and all warranties that may be implied by law, including any merchantability or fitness, for any particular purpose, are hereby limited to the duration of this written warranty. O.A.S. does not warrant or represent that the merchandise complies with the provisions of any law or acts unless the manufacturer so warrants. In no event shall O.A.S.'s liability under this warranty exceed the purchase price paid for the product and any legal actions brought against Oneida Air Systems shall be tried in the State of New York, County of Onondaga.

Oneida Air Systems shall in no event be liable for death, injuries to persons or property or for incidental, contingent, special, or consequential damages arising from the use of our product.

Oneida Air Systems does not warrant or authorize use of wood dust collectors for other purposes. This includes wood products that are treated, coated, or otherwise altered from their natural state.

***\*Note: Motors should be protected from extreme weather to prolong motor life. Single phase motors should only be started and stopped up to 4 - 10 times per hour. Starting single phase motors more frequently can cause heat build up and can cause the motor overload to trip or cause motor damage. In general, motors should be started and stopped as little as possible for maximum lifespan and best economy (electrical use).***

## ***Delivery Risk of Loss***

Products will be shipped to Buyer's single destination. Title and risk of loss shall pass to the Buyer upon delivery to such destination. Buyer pays transportation expenses. Dates of shipment are advisory and O.A.S. will make reasonable efforts to ship on or before the date states for shipment, however, O.A.S. shall not incur any liability for failure to ship on that date.

## ***Returned Goods Policy***

Buyer must inform O.A.S. of any shortage or damage, by so noting in writing, on the freight delivery bill prior to signing to indicate receipt of shipment. All claims, including claims covered under the limited warranty, are subject to inspection and investigation by O.A.S.. O.A.S. reserves the right to inspect and investigate all returned products before Buyer's claim is settled. All products returned for a refund must be unused, resaleable and purchased within the last six months. There are no refunds on flex hose, custom made components, or partial kit items. Kits must be returned in full (all components) for credit. *There will be a 25% restocking fee applied to any returned items.*

Some parts of this system are outsourced and not made in the USA.



# XV. Stand Assembly

Included Hardware:  
 (32) 5/16 x 1" Bolts - AFB155190  
 (32) 5/16 Nuts - AFW180000  
 (64) 5/16 Flat Washers - AFT155175

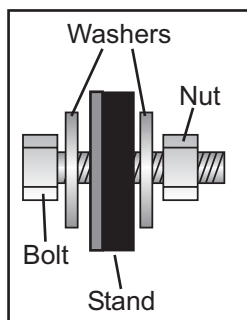
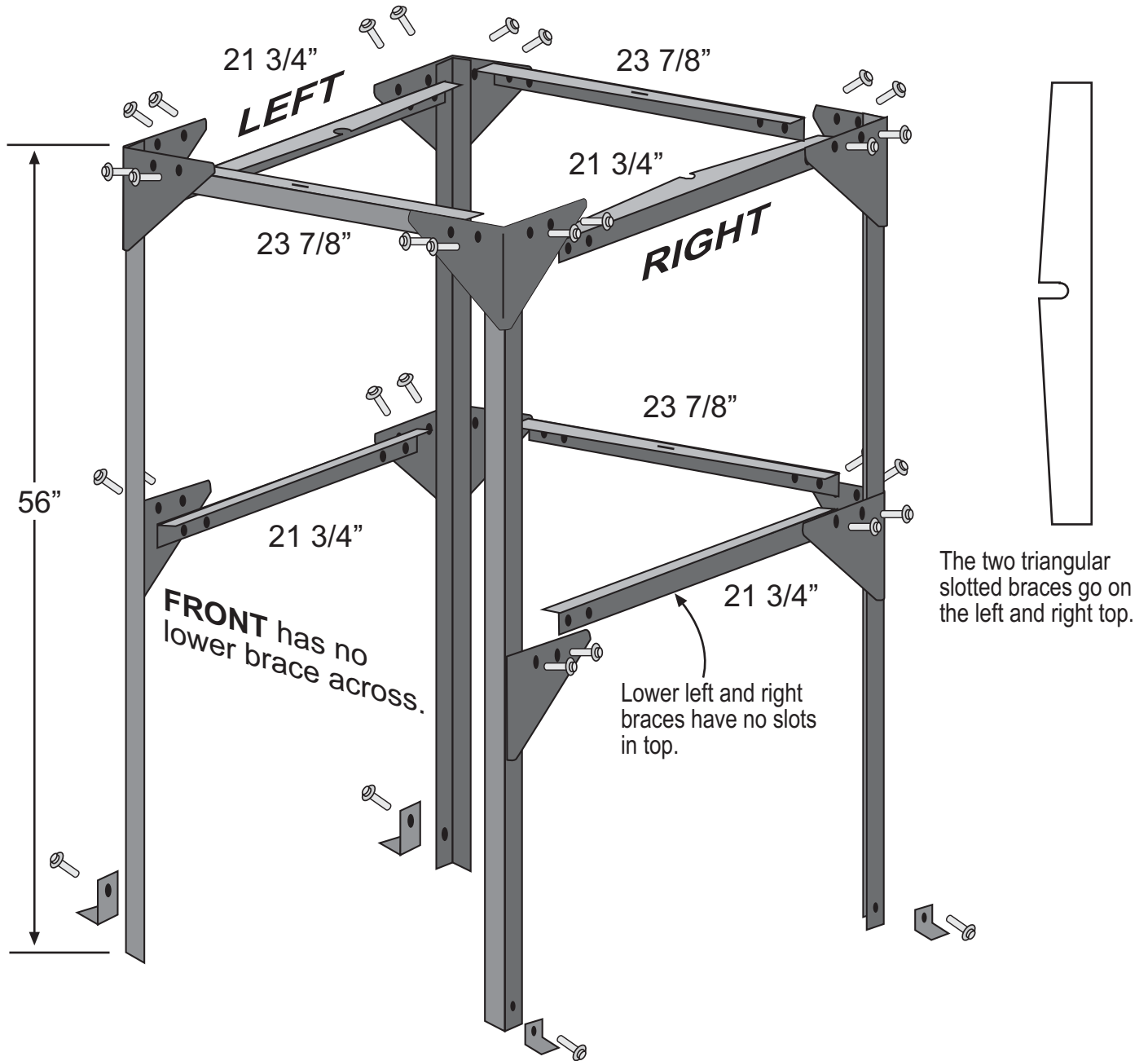

**Optional Angle Iron Stand**

Optional 35 gal. Angle Iron Stand - STG021035

1. Uprights - SXX000056
2. Braces - SXX000021

Optional 55 gal. Angle Iron Stand - STG023055

1. Uprights - SXX000068
2. Braces - SXX000021

# XVI. Accessories

## Bolt Together Angle Iron Stand

STG021035 - 35 gal. Stand  
STG021055 - 55 gal. Stand

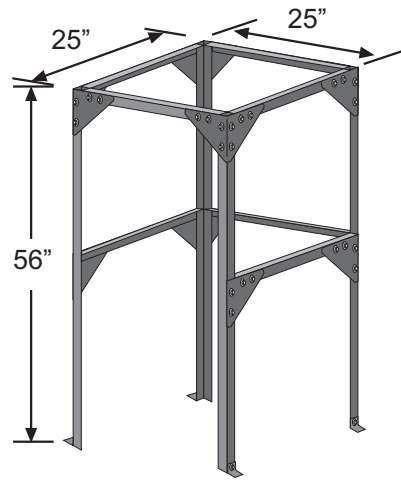

## Filter Efficiency Gauge

FXK000000

This easy to read gauge takes the guesswork out of knowing when your filters need to be cleaned and tells you how much pressure is backed up behind your filters. It reads pressure from plenum to gauge up to 8' away and allows you to keep your dust collection system running efficiently.

### Kit Contents:

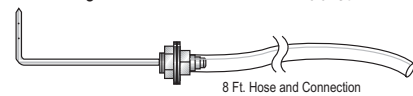
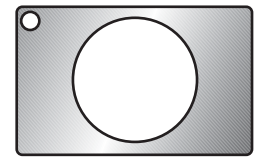
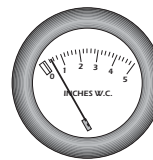

## Replacement Filter

FCS133900

13" x 39" / 95 Sq. Ft. Spun-Bonded. Filters 99.9% of test material from 0.2 to 2 microns.



## Dust Containers

35 gal. Fiber  
55 gal. Fiber  
55 gal. Steel



## The BAG Gripper™

ABX000000

The BAG Gripper provides the ability to use convenient plastic bags inside your dust drum. It provides a constant, negative pressure on the outside surface of the plastic bag that keeps it pulled tight against the sides of the dust drum. Can be used with 35 and 55 gal. barrels. Must be wired into your system.



# XVII. Fan Motor Maintenance

Per Baldor specifications, their 2 pole motors (3600 RPM) motors are to be relubricated **every 5500 hours**.

**Table 1 - Service Conditions**

Severity of Service	Ambient Temperature Maximum	Atmospheric Contamination	Type of Bearing
Standard	40° C	Clean, Little Corrosion	Deep Groove Ball Bearing
Severe	50° C	Moderate dirt, Corrosion	Ball Thrust, Roller
Extreme	>50° C* or Class H Insulation	Severe dirt, Abrasive dust, Corrosion	All Bearings
Low Temperature	<-30° C**		

\* Special high temperature grease is recommended.

\*\* Special low temperature grease is recommended.

**Table 2 - Lubrication Interval Multiplier**

Severity of Service	Multiplier
Standard	1.0
Severe	0.5
Extreme	0.1
Low Temperature	1.0

Per Baldor specifications, add .30 ounces (8.4 grams) of Mobil Polyrex grease by weight or .6 cubic inches (2 teaspoons) of Mobil Polyrex grease by volume.

## Procedure

Clean the grease fitting (or area around grease hole, if equipped with slotted grease screws). If motor has a purge plug, remove it. Motors can be regreased while stopped (at less than 80 C) or running. Apply grease gun to fitting (or grease hole). Too much grease or injecting grease too quickly can cause premature bearing failure. Slowly apply the recommended amount of grease, taking 1 minute or so to apply. Operate motor for 20 minutes, reinstall purge plug if previously removed. Caution: Keep grease clean. Mixing dissimilar grease is not recommended.

# XVIII. Remote Wiring Diagram

## Retrofit (Wiring) of Wireless Remote into 220V Control Circuit of Square D / Telemecanique Mag Starters

### Square D Telemecanique Mag Starters AMK Series

Plug into 9 pin female Molex on back panel of starter base.

**Important! Remove this factory installed Jumper Wire.**

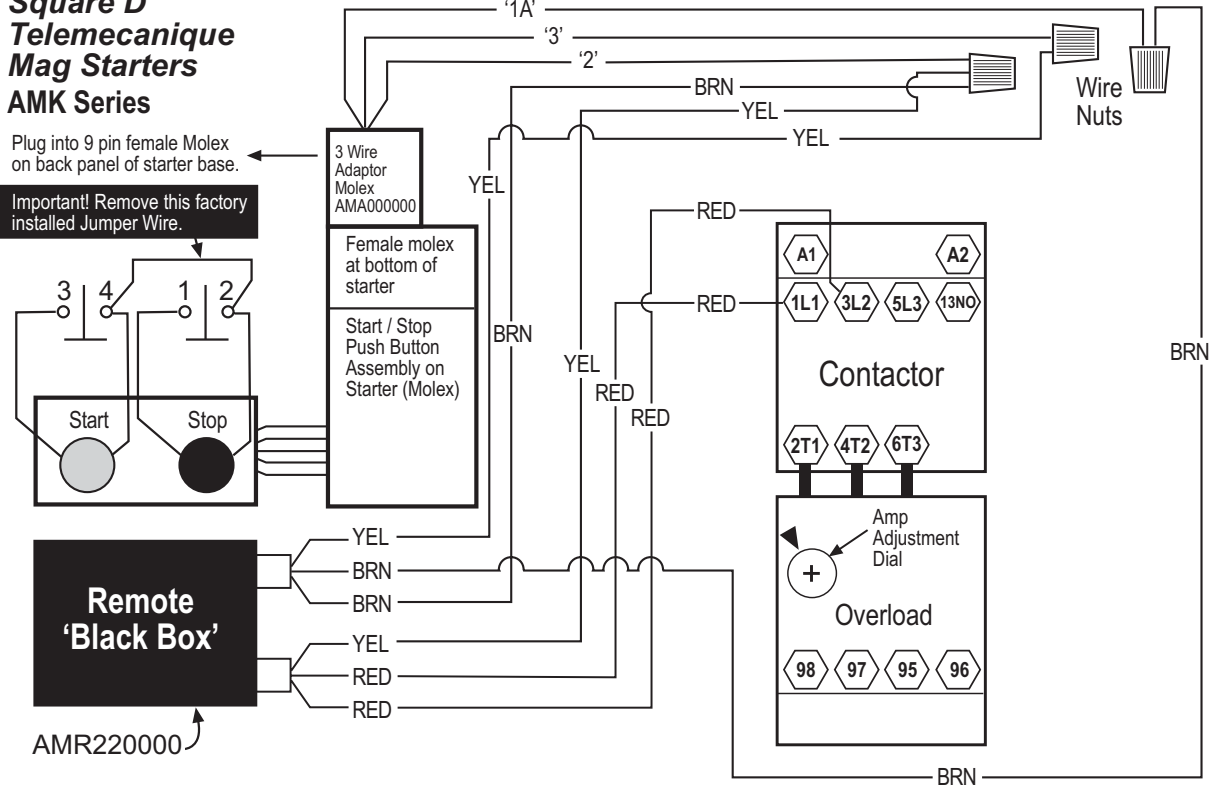

## Retrofit (Wiring) of Wireless Remote into 220V OAS Import Magnetic Starters: AMI020000 AMI030000

### NHD, Inc. Mag Starters

Remote is mounted inside starter top cover by using double-sided tape (supplied).

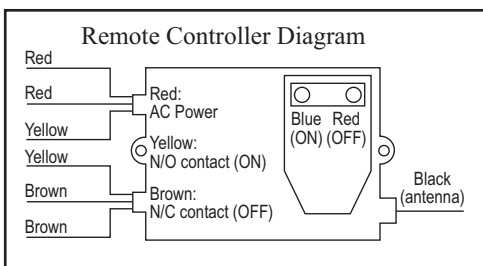
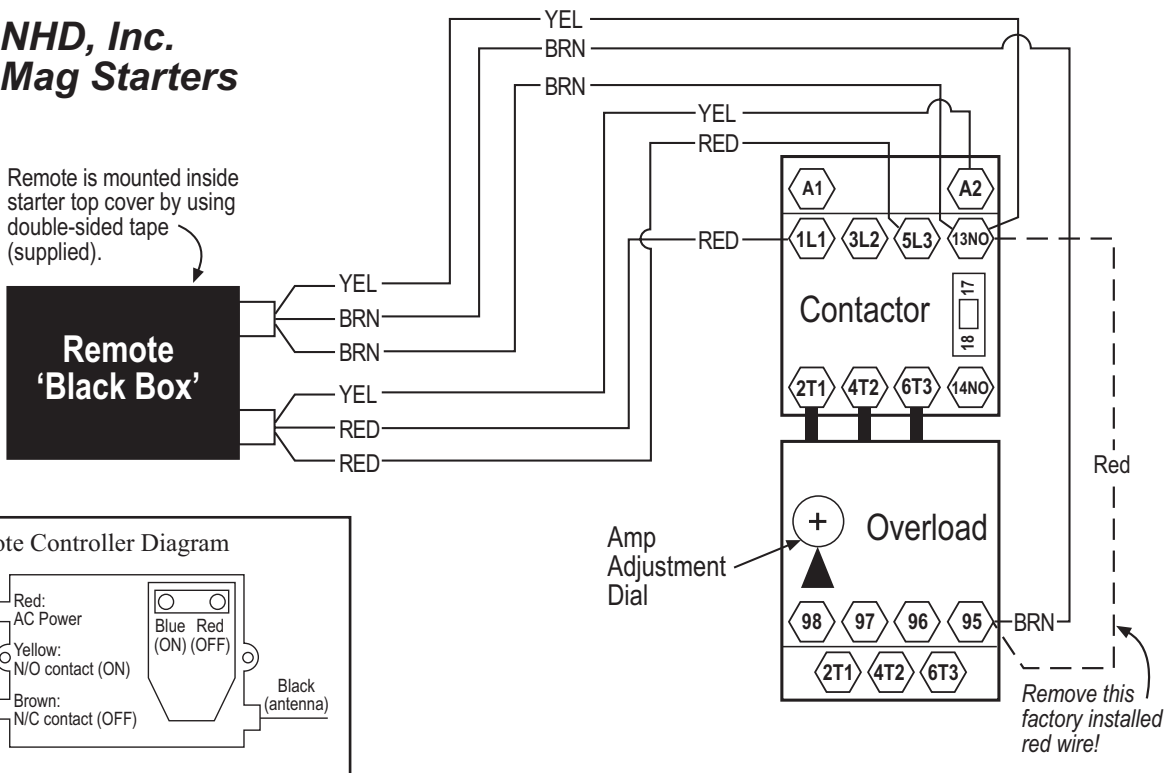

## Optional - XIX. Filter Efficiency Gauge Mounting Instructions

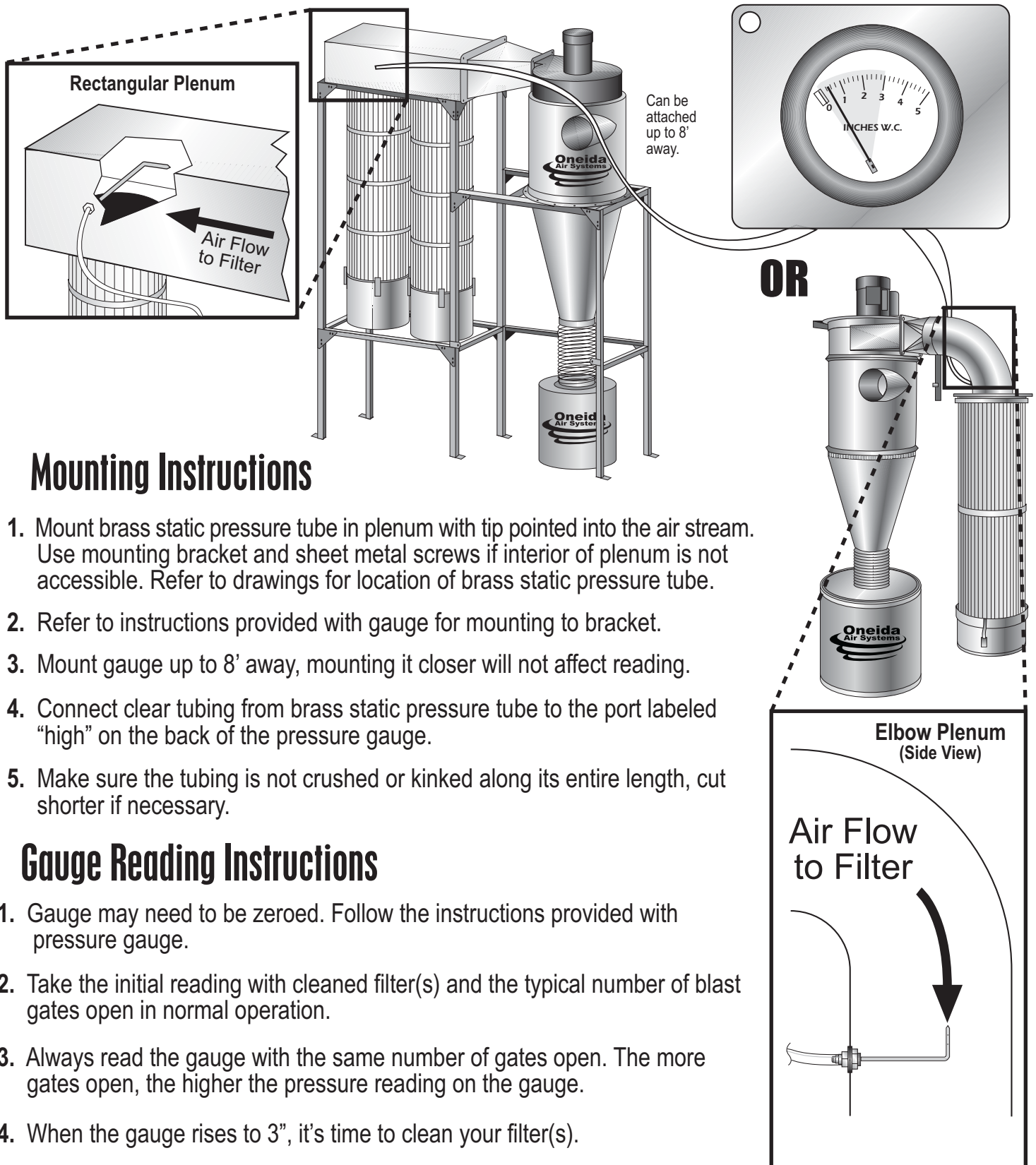

### Mounting Instructions

1. Mount brass static pressure tube in plenum with tip pointed into the air stream. Use mounting bracket and sheet metal screws if interior of plenum is not accessible. Refer to drawings for location of brass static pressure tube.
2. Refer to instructions provided with gauge for mounting to bracket.
3. Mount gauge up to 8' away, mounting it closer will not affect reading.
4. Connect clear tubing from brass static pressure tube to the port labeled "high" on the back of the pressure gauge.
5. Make sure the tubing is not crushed or kinked along its entire length, cut shorter if necessary.

### Gauge Reading Instructions

1. Gauge may need to be zeroed. Follow the instructions provided with pressure gauge.
2. Take the initial reading with cleaned filter(s) and the typical number of blast gates open in normal operation.
3. Always read the gauge with the same number of gates open. The more gates open, the higher the pressure reading on the gauge.
4. When the gauge rises to 3", it's time to clean your filter(s).

***After many cleaning cycles, a filter's pressure will rise after each cleaning. An older filter does not get as clean as a new filter.***