

ONKYO®

Compact Disc Player

DX-7355

Instruction Manual

Thank you for purchasing an Onkyo Compact Disc Player. Please read this manual thoroughly before making connections and plugging in the unit. Following the instructions in this manual will enable you to obtain optimum performance and listening enjoyment from your new Compact Disc Player. Please retain this manual for future reference.

Contents

Introduction 2

Connections 13

Operation 15

Others 26

WARNING:

TO REDUCE THE RISK OF FIRE OR ELECTRIC SHOCK, DO NOT EXPOSE THIS APPARATUS TO RAIN OR MOISTURE.

CAUTION:

TO REDUCE THE RISK OF ELECTRIC SHOCK, DO NOT REMOVE COVER (OR BACK). NO USER-SERVICEABLE PARTS INSIDE. REFER SERVICING TO QUALIFIED SERVICE PERSONNEL.



WARNING
RISK OF ELECTRIC SHOCK
DO NOT OPEN

AVIS
RISQUE DE CHOC ELECTRIQUE
NE PAS OUVRIR



The lightning flash with arrowhead symbol, within an equilateral triangle, is intended to alert the user to the presence of uninsulated "dangerous voltage" within the product's enclosure that may be of sufficient magnitude to constitute a risk of electric shock to persons.



The exclamation point within an equilateral triangle is intended to alert the user to the presence of important operating and maintenance (servicing) instructions in the literature accompanying the appliance.

Important Safety Instructions

1. Read these instructions.
2. Keep these instructions.
3. Heed all warnings.
4. Follow all instructions.
5. Do not use this apparatus near water.
6. Clean only with dry cloth.
7. Do not block any ventilation openings. Install in accordance with the manufacturer's instructions.
8. Do not install near any heat sources such as radiators, heat registers, stoves, or other apparatus (including amplifiers) that produce heat.
9. Do not defeat the safety purpose of the polarized or grounding-type plug. A polarized plug has two blades with one wider than the other. A grounding type plug has two blades and a third grounding prong. The wide blade or the third prong are provided for your safety. If the provided plug does not fit into your outlet, consult an electrician for replacement of the obsolete outlet.
10. Protect the power cord from being walked on or pinched particularly at plugs, convenience receptacles, and the point where they exit from the apparatus.
11. Only use attachments/accessories specified by the manufacturer.
12. Use only with the cart, stand, tripod, bracket, or table specified by the manufacturer, or sold with the apparatus. When a cart is used, use caution when moving the cart/apparatus combination to avoid injury from tip-over.

PORTABLE CART WARNING
SS125A
13. Unplug this apparatus during lightning storms or when unused for long periods of time.
14. Refer all servicing to qualified service personnel. Servicing is required when the apparatus has been damaged in any way, such as power-supply cord or plug is damaged, liquid has been spilled or objects have fallen into the apparatus, the apparatus has been exposed to rain or moisture, does not operate normally, or has been dropped.
15. Damage Requiring Service
Unplug the apparatus from the wall outlet and refer servicing to qualified service personnel under the following conditions:
 - A. When the power-supply cord or plug is damaged,
 - B. If liquid has been spilled, or objects have fallen into the apparatus,
 - C. If the apparatus has been exposed to rain or water,
 - D. If the apparatus does not operate normally by following the operating instructions. Adjust only those controls that are covered by the operating instructions as an improper adjustment of other controls may result in damage and will often require extensive work by a qualified technician to restore the apparatus to its normal operation,
 - E. If the apparatus has been dropped or damaged in any way, and
 - F. When the apparatus exhibits a distinct change in performance this indicates a need for service.
16. Object and Liquid Entry
Never push objects of any kind into the apparatus through openings as they may touch dangerous voltage points or short-out parts that could result in a fire or electric shock.
The apparatus shall not be exposed to dripping or splashing and no objects filled with liquids, such as vases shall be placed on the apparatus.
Don't put candles or other burning objects on top of this unit.
17. Batteries
Always consider the environmental issues and follow local regulations when disposing of batteries.
18. If you install the apparatus in a built-in installation, such as a bookcase or rack, ensure that there is adequate ventilation.
Leave 20 cm (8") of free space at the top and sides and 10 cm (4") at the rear. The rear edge of the shelf or board above the apparatus shall be set 10 cm (4") away from the rear panel or wall, creating a flue-like gap for warm air to escape.

Precautions

1. **Recording Copyright**—Unless it's for personal use only, recording copyrighted material is illegal without the permission of the copyright holder.
2. **AC Fuse**—The AC fuse inside the unit is not user-serviceable. If you cannot turn on the unit, contact your Onkyo dealer.
3. **Care**—Occasionally you should dust the unit all over with a soft cloth. For stubborn stains, use a soft cloth dampened with a weak solution of mild detergent and water. Dry the unit immediately afterwards with a clean cloth. Don't use abrasive cloths, thinners, alcohol, or other chemical solvents, because they may damage the finish or remove the panel lettering.

4. Power

WARNING

BEFORE PLUGGING IN THE UNIT FOR THE FIRST TIME, READ THE FOLLOWING SECTION CAREFULLY.

AC outlet voltages vary from country to country. Make sure that the voltage in your area meets the voltage requirements printed on the unit's rear panel (e.g., AC 230 V, 50 Hz or AC 120 V, 60 Hz).

The power cord plug is used to disconnect this unit from the AC power source. Make sure that the plug is readily operable (easily accessible) at all times.

Some models have a voltage selector switch for compatibility with power systems around the world. Before you plug in such a model, make sure that the voltage selector is set to the correct voltage for your area.

5. **Never Touch this Unit with Wet Hands**—Never handle this unit or its power cord while your hands are wet or damp. If water or any other liquid gets inside this unit, have it checked by your Onkyo dealer.

6. Handling Notes

- If you need to transport this unit, use the original packaging to pack it how it was when you originally bought it.
- Do not leave rubber or plastic items on this unit for a long time, because they may leave marks on the case.
- This unit's top and rear panels may get warm after prolonged use. This is normal.
- If you do not use this unit for a long time, it may not work properly the next time you turn it on, so be sure to use it occasionally.
- When you've finished using this unit, remove all discs and turn off the power.

7. Installing this Unit

- Install this unit in a well-ventilated location.
- Ensure that there's adequate ventilation all around this unit, especially if it's installed in an audio rack. If the ventilation is inadequate, the unit may overheat, leading to malfunction.

- Do not expose this unit to direct sunlight or heat sources, because its internal temperature may rise, shortening the life of the optical pickup.
- Avoid damp and dusty places, and places subject to vibrations from loudspeakers. Never put the unit on top of, or directly above a loudspeaker.
- Install this unit horizontally. Never use it on its side or on a sloping surface, because it may cause a malfunction.
- If you install this unit near a TV, radio, or VCR, the picture and sound quality may be affected. If this occurs, move this unit away from the TV, radio, or VCR.

8. **To Obtain a Clear Picture**—This unit is a high-tech, precision device. If the lens on the optical pickup, or the disc drive mechanism becomes dirty or worn, the picture quality may be affected. To maintain the best picture quality, we recommend regular inspection and maintenance (cleaning or worn part replacement) every 1,000 hours of use depending on the operating environment. Contact your Onkyo dealer for details.

9. Moisture Condensation

Moisture condensation may damage this unit.

Read the following carefully:

Moisture may condense on the lens of the optical pickup, one of the most important parts inside this unit.

- Moisture condensation can occur in the following situations:
 - The unit is moved from a cold place to a warm place.
 - A heater is turned on, or cold air from an air conditioner is hitting the unit.
 - In the summer, when this unit is moved from an air conditioned room to a hot and humid place.
 - The unit is used in a humid place.
- Do not use this unit when there's the possibility of moisture condensation occurring. Doing so may damage your discs and certain parts inside this unit.

If condensation does occur, remove all discs and leave this unit turned on for two to three hours. By this time, the unit will have warmed up and any condensation will have evaporated.

Precautions—Continued

This unit contains a semiconductor laser system and is classified as a “CLASS 1 LASER PRODUCT”. So, to use this model properly, read this Instruction Manual carefully. In case of any trouble, please contact the store where you purchased the unit.

To prevent being exposed to the laser beam, do not try to open the enclosure.

CAUTION:

CLASS 1M VISIBLE AND INVISIBLE LASER RADIATION WHEN OPEN. DO NOT VIEW DIRECTLY WITH OPTICAL INSTRUMENTS. THIS PRODUCT UTILIZES A LASER. USE OF CONTROLS OR ADJUSTMENTS OR PERFORMANCE OF PROCEDURES OTHER THAN THOSE SPECIFIED HEREIN MAY RESULT IN HAZARDOUS RADIATION EXPOSURE.

The label on the right is applied on the rear panel.



1. This unit is a CLASS 1 LASER PRODUCT and employs a laser inside the cabinet.
2. To prevent the laser from being exposed, do not remove the cover. Refer servicing to qualified personnel.

For British models

Replacement and mounting of an AC plug on the power supply cord of this unit should be performed only by qualified service personnel.

IMPORTANT

The wires in the mains lead are coloured in accordance with the following code:

Blue: Neutral

Brown: Live

As the colours of the wires in the mains lead of this apparatus may not correspond with the coloured markings identifying the terminals in your plug, proceed as follows:

The wire which is coloured blue must be connected to the terminal which is marked with the letter N or coloured black.

The wire which is coloured brown must be connected to the terminal which is marked with the letter L or coloured red.

IMPORTANT

The plug is fitted with an appropriate fuse. If the fuse needs to be replaced, the replacement fuse must be approved by ASTA or BSI to BS1362 and have the same ampere rating as that indicated on the plug. Check for the ASTA mark or the BSI mark on the body of the fuse.

If the power cord's plug is not suitable for your socket outlets, cut it off and fit a suitable plug. Fit a suitable fuse in the plug.

For European Models

Declaration of Conformity	
We, ONKYO EUROPE ELECTRONICS GmbH LIEGNITZERSTRASSE 6, 82194 GROEBENZELL, GERMANY	
declare in own responsibility, that the ONKYO product described in this instruction manual is in compliance with the corresponding technical standards such as EN60065, EN55013, EN55020 and EN61000-3-2, -3-3.	
GROEBENZELL, GERMANY	 K. MIYAGI
ONKYO EUROPE ELECTRONICS GmbH	

Features

- ❑ VLSC* (Vector Linear Shaping Circuitry)
- ❑ Massive Power Transformer
- ❑ Wolfson 192 kHz/24-Bit D/A Converter
- ❑ Audiophile-Grade Capacitors
- ❑ 2 Digital Outputs (Optical/Coaxial)
- ❑ Plays Audio CD, MP3 CD, CD-R/RWs
- ❑ Headphone Jack with Volume Control
- ❑ Quick Navigation for MP3 CD Playback
- ❑ 3-Mode Dimmer
- ❑ 2 Repeat Modes (Track/Full)
- ❑ 25 Track Programming
- ❑ Hi-Rigidity, Anti-Resonant Chassis
- ❑ Aluminium Front Panel
- ❑ RI-Compatible Remote Control

* VLSC and the VLSC logo are registered trademarks of Onkyo Corporation.

Supplied Accessories

Make sure you have the following accessories:

Audio cable (80 cm)

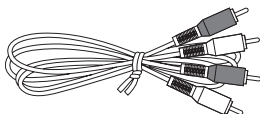

RI cable (80 cm)

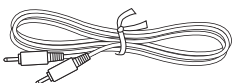

- To use **RI**, the DX-7355 must be connected with an **RI** cable and an audio cable.

Remote controller RC-686C & two batteries (AA/R6)

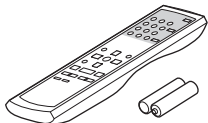

In catalogs and on packaging, the letter added to the end of the product name indicates the color of the DX-7355. Specifications and operation are the same regardless of color.

Table of Contents

Introduction

Important Safety Instructions	2
Precautions	3
Features	5
Supplied Accessories	5
Table of Contents	6
Front & Rear Panels	7
Front Panel.....	7
Display.....	8
Rear Panel.....	8
Remote Controller	9
RC-686C Remote Controller.....	9
Installing the Remote Controller's Batteries.....	10
Using the Remote Controller.....	10
About CDs	11

Connections

Connecting the DX-7355	13
Audio Connections.....	13
<i>RI</i> Connections.....	14

Operation

Before Using the DX-7355	15
Setting the Voltage Selector (Worldwide models only).....	15
Turning On the DX-7355	15
Playing CDs	16
Using the Remote Controller.....	17
Displaying CD Information.....	17
Selecting Tracks (MP3 Files).....	18
Selecting a Group during Playback (Search Mode).....	20
Displaying MP3 Information.....	20
Various Playback Modes	21
1-Group Playback (Only MP3 CDs).....	21
Random Playback.....	21
Memory Playback (For Audio CDs).....	22
Memory Playback (For MP3 CDs).....	23
Repeat Playback.....	24
Setting for MP3	24
Setting MP3 Preferences.....	24

Others

Troubleshooting	26
Specifications	27

Front & Rear Panels

The page numbers in parentheses show where you can find the main explanation for each item.

Front Panel

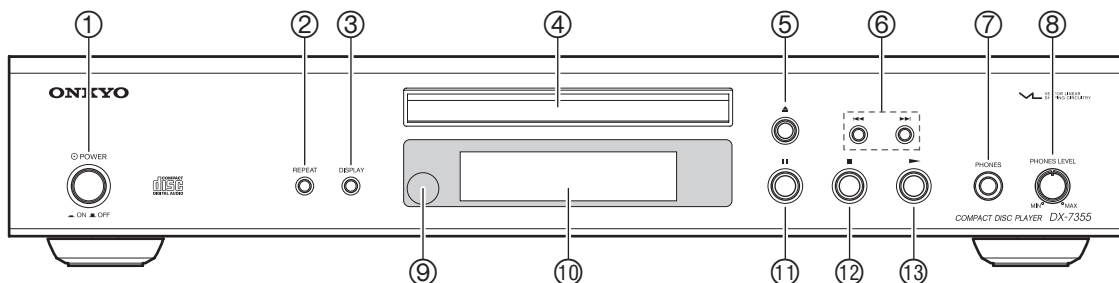

- ① **POWER switch (15)**
Press to turn on/off the DX-7355.
- ② **REPEAT button (24)**
Press to set the repeat playback or 1-repeat playback mode.
- ③ **DISPLAY button (17, 20)**
Press to change the displayed information.
- ④ **Disc tray (16)**
The CD is loaded here.
- ⑤ **Open/Close [▲] button (16)**
Press to open and close the disc tray.
- ⑥ **[◀/▶] buttons (16)**
Press to select the previous or next track.
Hold down the buttons to fast-reverse or fast-forward during playback.
For MP3 CDs, these buttons are also used for navigation.
- ⑦ **PHONES jack**
This is a standard stereo jack for connecting stereo headphones.
- ⑧ **PHONES LEVEL knob**
Use to control the phones level.
Turn the knob clockwise to increase the phones level and counterclockwise to decrease it.
- ⑨ **Remote Control Sensor (10)**
- ⑩ **Display**
See next page.
- ⑪ **Pause [■] button (16)**
Press to pause playback.
- ⑫ **Stop [■] button (16)**
Press to stop playback.
- ⑬ **Play [▶] button (16)**
Press to start playback.

Display

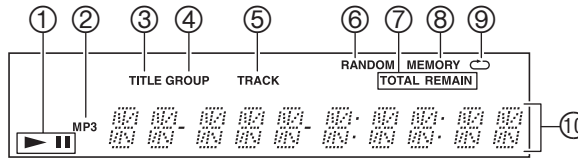

① **Play & Pause indicators**

Illuminate in play or pause mode.

② **MP3 indicator**

Illuminates when MP3 CD is loaded.

③ **TITLE indicator**

Illuminates when the title (ID3 Tags) is displayed for MP3 track.

④ **GROUP indicator**

Illuminates when the group number is displayed for the selected MP3.

⑤ **TRACK indicator**

Illuminates when the track number is displayed.

⑥ **RANDOM indicator**

Illuminates when the playback mode is set to random playback.

⑦ **TOTAL & REMAIN indicators**

Illuminate when the remaining time is shown. (Only when audio CD is loaded; not available when MP3 CD is loaded.)

REMAIN: Displays the remaining playback time of the track.

TOTAL REMAIN: Displays the remaining playback time of the disc.

⑧ **MEMORY indicator**

Illuminates when the playback mode is set to memory playback.

⑨ **Repeat indicator**

Illuminates when the repeat playback is set.

⑩ **Message area**

Various information is displayed here.

Rear Panel

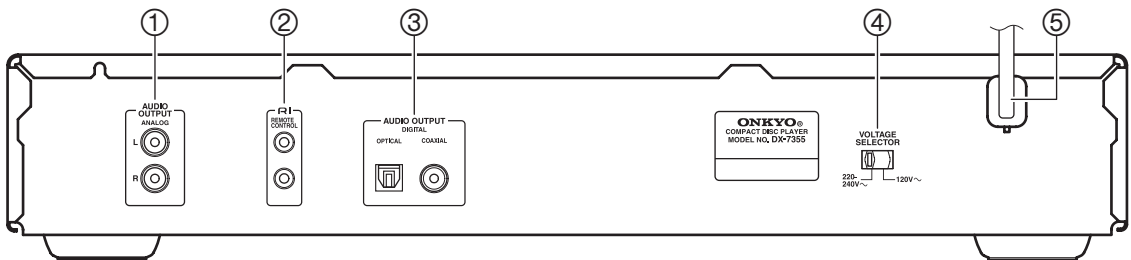

① **ANALOG AUDIO OUTPUT**

This analog audio output can be connected to an amplifier's analog input by using the supplied audio cable.

② **RI REMOTE CONTROL jacks**

These two identical **RI** (Remote Interactive) jacks can be connected to the **RI** jacks on your other Onkyo components for interactive control. To use **RI**, the DX-7355 must be connected with an **RI** cable and an audio cable.

③ **DIGITAL AUDIO OUTPUT OPTICAL/COAXIAL**

These two digital audio outputs can be connected to a digital audio input on an amplifier or recorder.

④ **VOLTAGE SELECTOR switch**

For Worldwide models only.

⑤ **Power cord**

The power cord should be connected to a suitable power source.

See pages 13–15 for connection information.

Remote Controller

RC-686C Remote Controller

The page numbers in parentheses show where you can find the main explanation for each item.

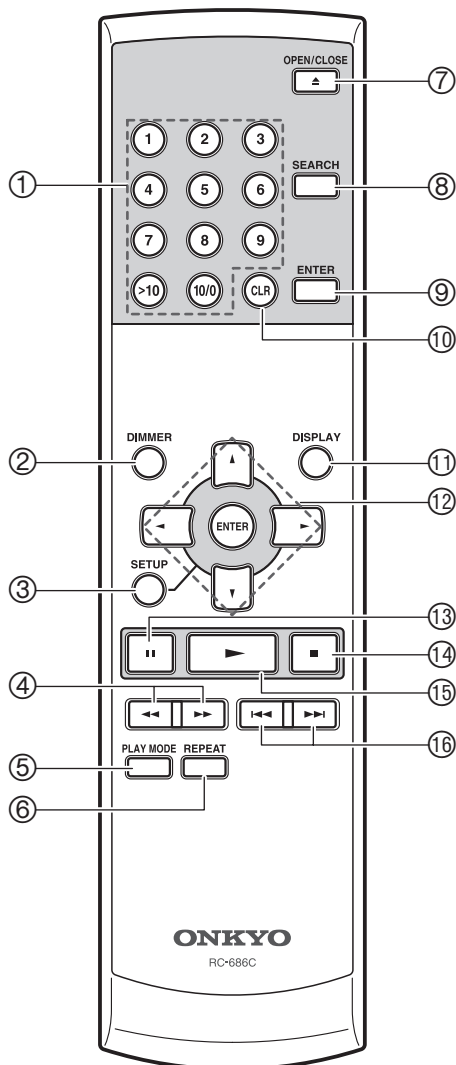

① **Number buttons (17, 20)**

Use to enter track numbers.

② **DIMMER button (17)**

Press to adjust the display brightness. The brightness changes in this order:

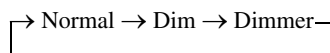

③ **SETUP button (24)**

Press to display the screen for various settings.

④ **[<</>>] buttons (17)**

Hold down to fast-reverse or fast-forward during playback.

When the memory playback is set, press these buttons to confirm the program in memory.

⑤ **PLAY MODE button (21, 22, 23)**

Press to change the settings for memory playback, random playback, and 1-group playback modes.

⑥ **REPEAT button (24)**

Press to set the repeat playback or 1-repeat playback mode.

⑦ **OPEN/CLOSE button (17)**

Press to open and close the disc tray.

⑧ **SEARCH button (20)**

For MP3 CDs, the button is used to search and select a track (file) number or a group (folder) number.

⑨ **ENTER button**

Press to set a selected preference.

⑩ **CLR (Clear) button (22)**

Press to cancel an input of data, while entering numeric values.

Press to remove the last track in the program, while registering memory.

⑪ **DISPLAY button (17, 20)**

Press to change the displayed information.

⑫ **Arrow and ENTER buttons**

Press the Arrow buttons to configure various settings, and then press the ENTER or Arrow buttons to set them.

These buttons can be also used to select a track.

⑬ **Pause [||] button (17)**

Press to pause playback.

⑭ **Stop [■] button (17)**

Press to stop playback.

⑮ **Play [▶] button (17)**

Press to start playback.

⑯ **[◀◀/▶▶] buttons (17)**

Press to select the previous or next track.

Installing the Remote Controller's Batteries

- 1 To open the battery compartment, press the small hollow and slide open the cover.**

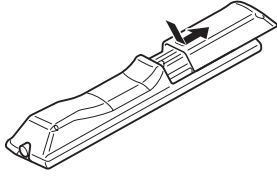

- 2 Insert the two supplied batteries (AA/R6) in accordance with the polarity diagram inside the battery compartment.**

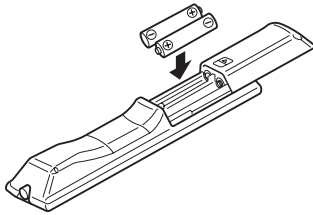

- 3 Slide the cover shut.**

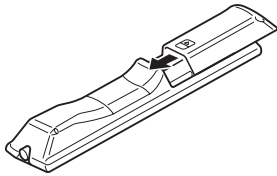

Notes:

- If the remote controller doesn't work reliably, try replacing the batteries.
- Don't mix new and old batteries or different types of batteries.
- If you intend not to use the remote controller for a long time, remove the batteries to prevent damage from leakage or corrosion.
- Flat batteries should be removed as soon as possible to prevent damage from leakage or corrosion.

Using the Remote Controller

To use the remote controller, point it at the DX-7355's remote control sensor, as shown.

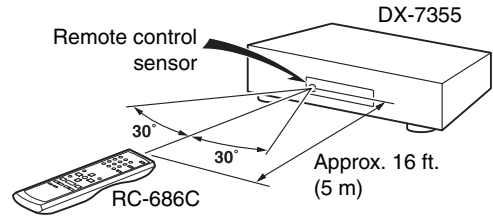





Notes:

- The remote controller may not work reliably if the DX-7355 is subjected to bright light, such as direct sunlight or inverter-type fluorescent lights. Keep this in mind when installing the DX-7355.
- If another remote controller of the same type is used in the same room, or the DX-7355 is installed close to equipment that uses infrared rays, the remote controller may not work reliably.
- Don't put anything, such as a book, on the remote controller, because the buttons may be pressed inadvertently, thereby draining the batteries.
- The remote controller may not work reliably if the DX-7355 is installed in a rack behind colored glass doors. Keep this in mind when installing the DX-7355.
- The remote controller will not work if there's an obstacle between it and the DX-7355's remote control sensor.

About CDs

Supported Discs

The DX-7355 supports the following discs.

Disc	Logo	Format or file type
Audio CD		PCM
CD-R		Audio CD, MP3
		MP3
CD-RW		Audio CD, MP3
		MP3
CD Extra		Audio CD (Session 1), MP3 (Session 2)

- Some audio CDs use copy protection that doesn't conform to the official CD standard. Since these are non-standard discs, they may not play properly in the DX-7355.
- The DX-7355 supports CD-R and CD-RW discs. However, some CD-R and CD-RW discs may not work properly for any of the following reasons: disc burner characteristics, disc characteristics, the disc is damaged or dirty. See the manual supplied with your disc burner for more information. Condensation or dirt on the optical pickup lens can also affect playback.
- The DX-7355 supports 8 cm and 12 cm discs.
- If you load any other non-supported discs for reading or playback purpose, they may cause noise or not operate normally.
- The DX-7355 does not support disc types not listed.
- Don't use discs with an unusual shape, such as those shown below, because you may damage the DX-7355.



- Don't use discs that have residue from adhesive tape, rental discs with peeling labels, or discs with custom-made labels or stickers. Doing so may damage the DX-7355 and you may not be able to remove the disc properly.

Discs Made on Personal Computers

Discs made on personal computers, including those of a compatible format, may not work properly in the DX-7355 because of incorrect settings in the disc burning software. Check the manuals supplied with your disc

burning software for additional compatibility information.

MP3 Compatibility

- MP3 discs must be ISO 9660 Level 1 or Level 2, Romeo or Joliet compliant. Supported formats: Mode 1, Mode 2 XA Form 1.
- Folders can be up to eight levels deep.
- MP3 files must be MPEG-1/MPEG-2 Audio Layer 3 format with a sampling rate of between 8 kHz and 48 kHz and a bit-rate of between 8 kbps and 320 kbps (128 kbps recommended). Incompatible files cannot be played.
- Constant bit rate MP3 files are recommended, however, variable bit rate (VBR) MP3 files between 8 kbps and 320 kbps are supported. (Playing times may display incorrectly.)
- MP3 files must have a ".mp3" or ".MP3" file name extension. MP3 files without the proper extension will not be recognized. To prevent noise and malfunction, do not use these extensions for other types of files.
- The DX-7355 supports up to 499 total tracks including the folders of a disc and the MP3 files, however, the maximum number of folders may not exceed 99. Files and folders in excess of this cannot be played. Note that if the file and folder structure is very complicated, the DX-7355 may not be able to read or play all of the MP3 files on the disc.
- Disc, file and folder names may contain up to 32 characters.
- The maximum time that can be displayed for a single track is 99 minutes and 59 seconds.
- The remaining time cannot be displayed when playing MP3 files.
- MP3 file and folder names (excluding the extension) are shown on the display.
- The emphasis is not supported.
- Multisession discs are supported, however, some multisession discs may take a long time to load and some may not load at all. When burning CDs we recommend that you use a single-session (disc-at-once), and select "Disc Close."
- Normally, the music in the audio session of a CD Extra disc is played. However, you can set the DX-7355 so that it plays any MP3 files in the data session of a CD-R/RW disc instead. If the data session contains no MP3 tracks, the audio session will be played regardless.
- The following ID3 tags are supported: versions 1.0/1.1 and 2.2/2.3/2.4. Version 2.5 and later are not supported. Normally, version 2.2/2.3/2.4 tags have priority and will be displayed regardless of the ID3 VER 1 preference on page 25.

About CDs—Continued

- For ID3 version 2 tags, information contained in the beginning of the file are recognized. We recommend that you include only title, artist name, and album name information in ID3 tags. Compressed, encrypted, and unsynchronized ID3 tags cannot be displayed.
- Some MP3 files may have ID3 tags whose information can be displayed no longer than 31 characters.

Notes:

- With CD-ROM, CD-R, and CD-RW discs that contain many files and folders, and files other than MP3s, it may take a long time to read the disc. We recommend that you include only MP3 files on your discs, use about 20 folders, and limit folder nesting to three levels deep.
- **In this manual, MP3 files are referred to as *tracks*.**
- **Likewise, folders (directories) are referred to as *groups*.**

About Playing Copy-controlled CDs

Some copy-controlled CDs may not conform to the official CD standard. These special discs may not play properly on the DX-7355.

Don't load discs that are not audio discs (e.g., CD-ROMs designed for use with computers), as these may damage your speakers or amplifier.

Disc Content Organization

CD

CDs contain tracks.



MP3

MP3 CDs contain MP3 Tracks organized into Groups.

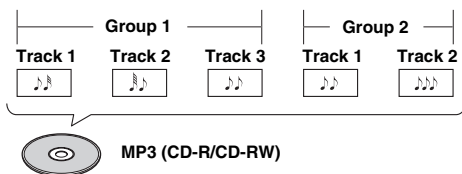

Handling Discs

- Never touch the underside of a disc. Always hold discs by the edge, as shown.

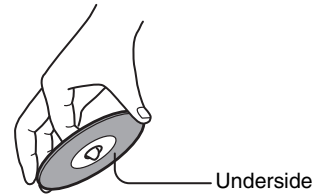

- Never attach adhesive tape or sticky labels to discs.



Cleaning Discs

- For best results, keep your discs clean. Fingerprints and dust can affect the sound quality and should be removed as follows. Using a clean soft cloth, wipe from the center outwards, as shown. Never wipe in a circular direction.



- To remove stubborn dust or dirt, wipe the disc with a damp soft cloth, and then dry it with a dry cloth.
- Never use solvent-based cleaning fluids, such as thinner or benzene, commercially available cleaners, or antistatic sprays intended for vinyl records, as they may damage the disc.

Storing Discs

- Don't store discs in places subject to direct sunlight or near heat sources.
- Don't store discs in places subject to moisture or dust, such as in a bathroom or near a humidifier.
- Always store discs in their cases and vertically. Stacking, or putting objects on unprotected discs may cause warping, scratches, or other damage.

Connecting the DX-7355

Audio Connections

- Before making any connections, read the manuals supplied with your other components.
- Don't connect the power cord until you've completed and double-checked all connections.

Connection Color Coding

RCA-type audio connections are usually color-coded: red and white. Use red plugs to connect right-channel audio inputs and outputs (typically labeled "R"). Use white plugs to connect left-channel audio inputs and outputs (typically labeled "L").

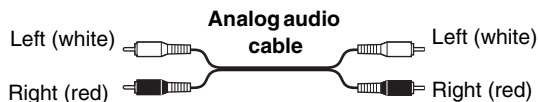

- Push plugs in all the way to make good connections (loose connections can cause noise or malfunctions).
- To prevent interference, keep audio cables away from power cords and speaker cables.

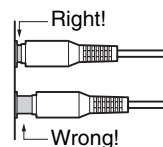

Optical Digital Jack

The DX-7355's optical digital jack has a shutter-type cover that opens when an optical plug is inserted and closes when it's removed. Push the plug in all the way.

Caution: To prevent shutter damage, hold the optical plug straight when inserting and removing.

Note:

Do not put anything on top of the DX-7355, as it may interfere with proper ventilation.

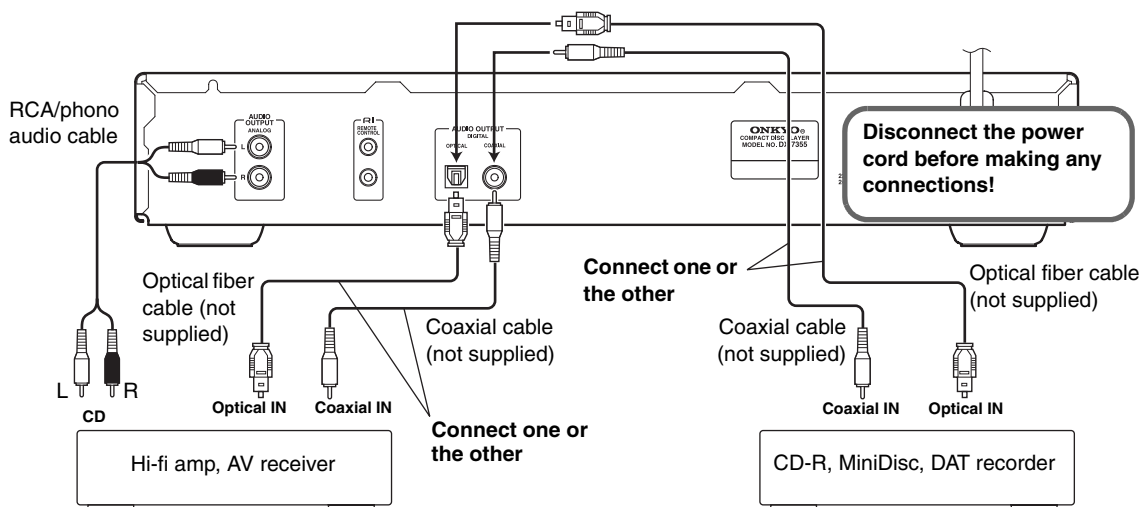

RI Connections

With **RI** (Remote Interactive) you can control the DX-7355 together with your other **RI**-compatible Onkyo AV components. With some Onkyo AV receivers you can use one remote controller to control all your Onkyo components and use the following special **RI** functions:

Direct Change

If your DX-7355 is connected to an **RI**-compatible Onkyo hi-fi amp or AV receiver, when you start playback on the DX-7355, the AV receiver will select the DX-7355 as the input source.

Remote Control Operation

You can control the DX-7355 by using your Onkyo amplifier's remote controller. See the amplifier's instruction manual for details.

To use the **RI** functions, you need to connect one of the DX-7355's **RI** connectors to an **RI** connector on another AV component in your system by using the supplied **RI** cable.

See the manuals supplied with your other **RI**-compatible AV components for more information.

Notes:

- Use only **RI** cables for **RI** connections.
- **To use RI you must make an analog RCA/phono connection between your DX-7355 and Onkyo AV receiver even if they are connected digitally.**
- The DX-7355 has two **RI** connectors. You can connect either one to your Onkyo hi-fi amp or AV receiver. The other connector is for connecting additional **RI**-compatible components.
- Connect the DX-7355's **RI** connector to only Onkyo AV components. Connecting to other manufacturer's AV components may cause them to malfunction.
- Some Onkyo **RI**-compatible AV components may not support the special functions described here.

To use RI you must make an analog audio connection (RCA/phono) between the DX-7355 and your other Onkyo equipment even if they are connected digitally.

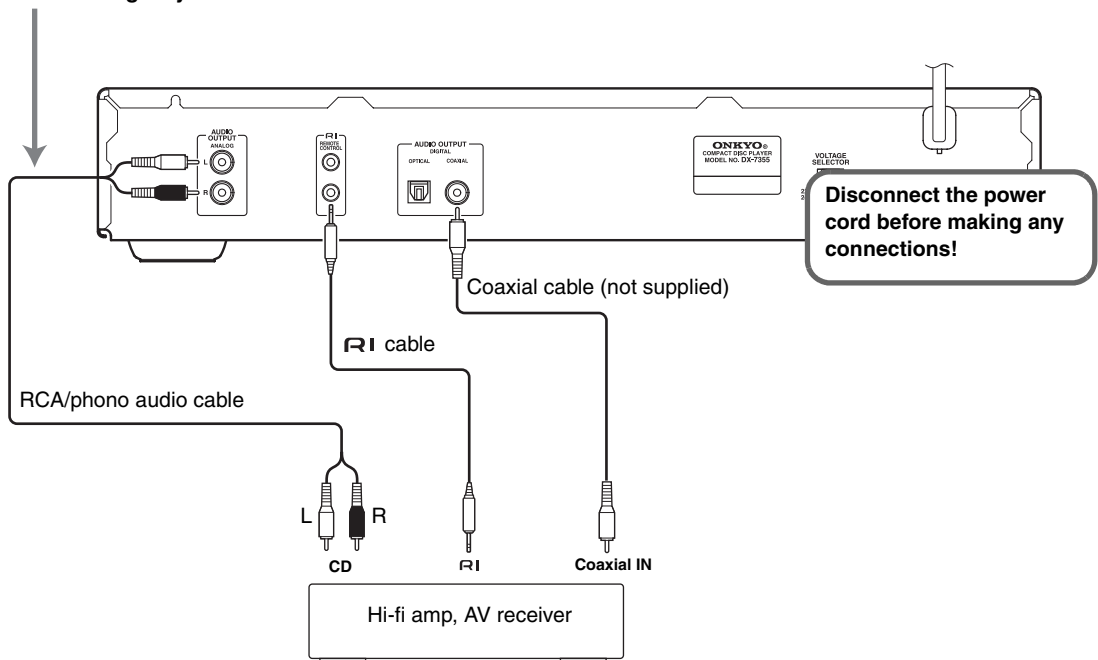

Before Using the DX-7355

- Turn off the power before changing the switch settings.
- On changing the switch settings, DX-7355 is initialized to its factory defaults. Radio presets and other settings are deleted.

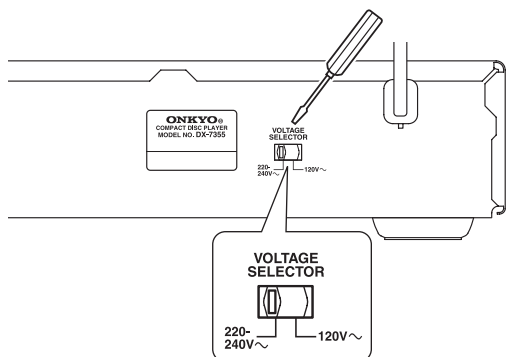

Setting the Voltage Selector (Worldwide models only)

Worldwide models are equipped with a voltage selector to conform with local power supplies. Be sure to set this switch to match the voltage of the power supply in your area before plugging in the unit.

Determine the proper voltage for your area: 220-240 V or 120 V.

If the preset voltage is not correct for your area, insert a screwdriver into the groove in the switch. Slide the switch all the way to the right (120 V) or to the left (220-240 V), whichever is appropriate.

Turning On the DX-7355

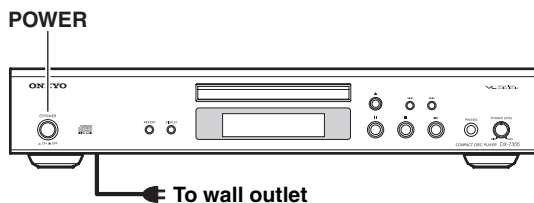

1 Plug the power cord into a suitable wall outlet.

2 Press the DX-7355's [POWER] switch.
Make sure the switch is set to ON .
The DX-7355 turns on.





To Turn off the DX-7355

Press the [POWER] switch.

Make sure the switch is set to OFF .

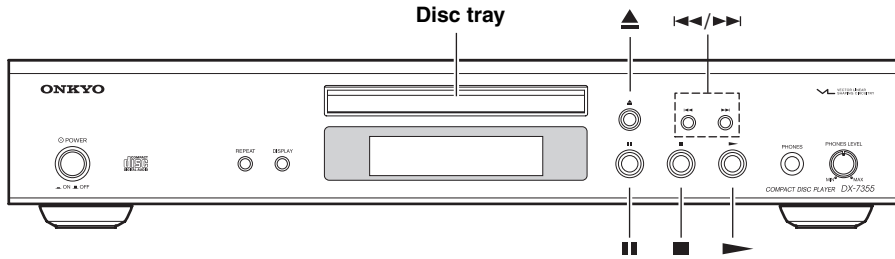
Playing CDs



- 1** 
Press the Open/Close [▲] button to open the disc tray.
- 2** **Place the CD on the tray with the label-side facing up.**
Place 8 cm CDs in the center of the tray.
- 3** 
To start playback, press the Play [▶] button.
The disc tray closes and playback starts.

- Audio CD Display** Lights up while the disc information is being displayed.

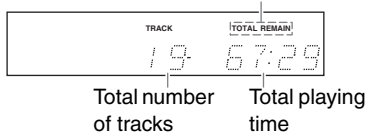

- MP3 CD Display**

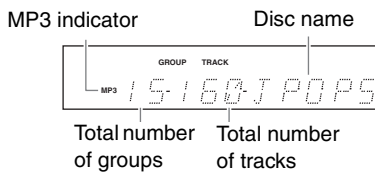

To Select Tracks

Press the [▶▶] button to select the next track or the [◀◀] button to select the previous track.

- If you press the [◀◀] button during playback or while playback is paused, the beginning of the current track is selected.
- If you select a track while playback is stopped, press the Play [▶] button to start playback.

Note:

For MP3 CDs, you can select MP3 tracks in other groups.

To Fast-Forward or Fast-Rewind

During playback or while playback is paused, hold down the [▶▶] button to fast-forward or the [◀◀] button to fast-rewind.

Note:

For MP3 CDs, fast-rewind only works within the MP3 track that's currently playing.

To Pause Playback

Press the Pause [||] button. The Pause [||] indicator appears.

To resume playback, press the Play [▶] or Pause [||] button again.

To Stop Playback

Press the Stop [■] button.

To Eject the CD

Press the Open/Close [▲] button to open the disc tray.

Using the Remote Controller

Use the number buttons as shown in the examples below to select tracks.

To select: Press:

Track #8 8

Track #10 10/0

Track #34 >10 3 4

>10 Used to enter numbers over 10.

10/0 Used to enter number 10 or 0.

For MP3 CDs, you can select tracks in the current group with these buttons.

Press to pause playback.

To resume playback, press the Pause [||] or Play [▶] button.

Press to fast-forward or fast-reverse.

During playback or while playback is paused, hold down the Fast Forward [▶▶] button to fast-forward, or the Fast Reverse [◀◀] button to fast-reverse.

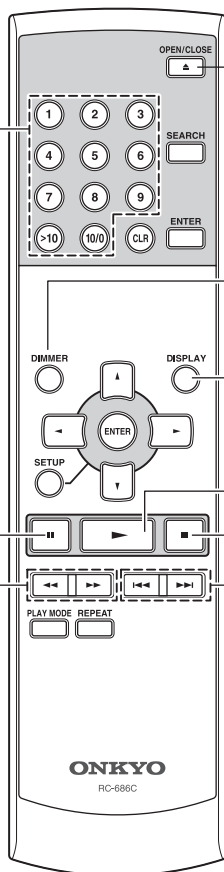

Press to open and close the disc tray.

Press to adjust the display brightness.

By pressing this button, the brightness changes in order of "Normal", "Dim", and "Dimmer".

Press to display more CD information.

Press to start playback.

Press to stop playback.

Press to select tracks.

- Press the Previous [◀◀] button to locate the beginning of the currently playing or paused track. Press it repeatedly to select earlier tracks.
- Press the Next [▶▶] button repeatedly to select subsequent tracks.

For MP3 CDs, you can select tracks in other groups (see page 18).

Displaying CD Information

Press the DX-7355 or the remote controller's [DISPLAY] button (repeatedly) display the following CD information.

While playback is stopped

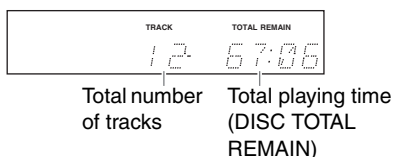

During playback or while playback is paused

Elapsed track time: The length of time that the current track has been playing (default display).



Remaining track time: The amount of time remaining for the current track (REMAIN indicator appears).



Remaining disc time: The amount of time remaining for the entire disc (TOTAL and REMAIN indicators appear).



Note:

See page 20 for details on displaying MP3 information.

Selecting Tracks (MP3 Files)

For MP3 CDs, tracks (MP3 files) may be organized in a hierarchically, with groups (folders) containing tracks and subgroups, as shown below.

- In this manual, MP3 files are referred to as *tracks*.
- Likewise, folders (directories) are referred to as *groups*.

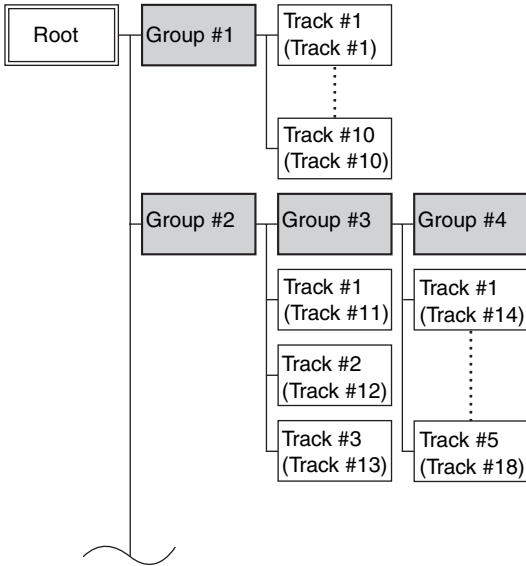

If you don't select a specific MP3 track or group for playback, all of the MP3 tracks on the CD will be played in numerical order starting with track #1 in parentheses. For the DX-7355, there are two modes for selecting tracks (MP3 files): *Navigation mode* and *All Group mode*.

In Navigation mode, you can select tracks (MP3 files) by navigating through the group (folder) hierarchy, moving in and out of groups (folders) and subgroups (subfolders).

In All Group mode, all groups (folders) appear at the same level, making it easy to select groups (folders) regardless of the hierarchy.

While playback is stopped, press the [▼] button to enter the Navigation mode or the [▲] button to enter the All Group mode.

When operating directly the DX-7355, press the Stop [■] button to enter the Navigation mode or hold down the Stop [■] button for about 2 seconds to enter the All Group mode.

The combination between the way to press the button and the corresponding playback mode can be exchanged. When operating on DX-7355, the track selection in the Navigation and All Group modes can be disabled. (See "STOP KEY" of "Setting MP3 Preferences" on page 25.)

Selecting Tracks in Navigation Mode

In Navigation mode, you can select tracks by navigating through the group hierarchy. This mode can only be used while playback is stopped.

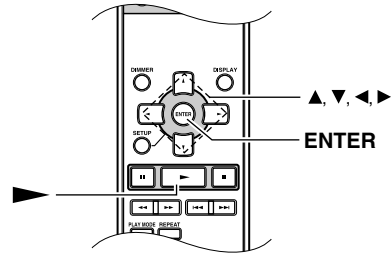

If any of random playback, memory playback, or 1-group playback mode is currently selected, press the [PLAY MODE] button to cancel the mode before proceeding.

1	<p>While playback is stopped, press the [▼] button.</p> <p>The DX-7355 enters Navigation mode and "ROOT" appears on the display.</p>
2	<p>Press the [▼] button.</p> <p>The first group name in ROOT appears on the display.</p> <p>If the disc contains no groups, the first track name is displayed.</p>
3	<p>Use the [◀]/[▶] buttons to select other groups and tracks at the same level.</p> <ul style="list-style-type: none"> • Groups that don't contain tracks or subgroups can't be selected. • Repeat steps 2 and 3 to select the tracks and subgroups in that group. • To move up a level, press the [▲] button. • To cancel the procedure at any point, press the Stop [■] button.
4	<p>To start playback, press the Play [▶] button.</p> <p>Playback will start with the specified track or group and continue until all of the tracks on the disc have been played.</p>

When Operating Directly on DX-7355

1. While playback is stopped, press the Stop [■] button to display “ROOT” on the display. The DX-7355 enters Navigation mode.
2. Press the Play [▶] button to display the first group name in ROOT.
3. Press the Previous and Next [◀◀]/[▶▶] buttons to select a group.
4. Press the Play [▶] button. Repeat steps 3 and 4 to select the tracks and sub-groups in that group.
5. Press the Previous and Next [◀◀]/[▶▶] buttons to select a track.
 - To move up a level, press the Stop [■] button.
6. Press the Play [▶] button to start playback.

Selecting Tracks in All Group Mode

In All Group mode, you don't have to navigate the group hierarchy because all groups that contain tracks appear at the same level.

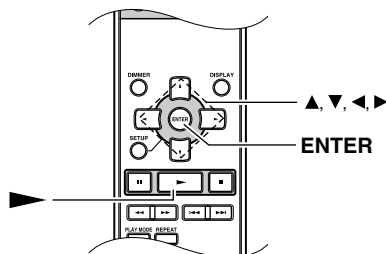

If any of random playback, memory playback, or 1-group playback mode is currently selected, press the [PLAY MODE] button to cancel the mode before proceeding.

1

While playback is stopped, press the [▲] button.



The DX-7355 enters All Group mode, and “1-” appears on the display.

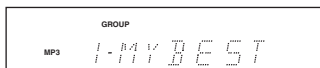

2

Use the [◀]/[▶] buttons to select the other groups.

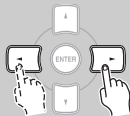

You can select any group that contains tracks.

To play the first track in the selected group, go to Step 4.

3

Press the [▼] button.



The first track name inside the group is displayed.

Use the [◀]/[▶] buttons to select the tracks within the group.

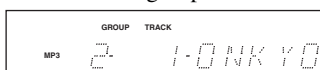

- To select another group, press the [▲] button again, and then use the [◀]/[▶] buttons to select it.
- To cancel the procedure at any point, press the Stop [■] button.

To Select Groups and Tracks by Number

1. Use the number buttons as shown in the examples below to enter group numbers.

To select: Press:

Track #8 (8)

Track #10 (>10)

Track #34 (>10) (3) (4)

(>10) Used to enter numbers over 10.

If playback is stopped, playback starts with the first track in the specified group.

2. Use the number buttons to enter the track number.

The playback starts.

If a group contains more than 99 tracks, single- and double-digit track numbers must be preceded by zeros. For example, to specify track #8, press [8]. To specify track #34, press [>10], [10/0], [3], and [4]. To specify track #134, press [>10], [1], [3], and [4].

4

To start playback, press the [ENTER] or Play [▶] button.



Playback will start with the specified track or group and continue until all of the track on the disc have been played.

When Operating Directly on DX-7355

1. While playback is stopped, press the Stop [■] button for about 2 seconds until “1-” appears on the display. The DX-7355 enters All Group mode.
2. Press the Previous and Next [◀◀]/[▶▶] buttons to select a group.
3. Press the Play [▶] button.
4. Press the Previous and Next [◀◀]/[▶▶] buttons to select a track.
 - To move up a level, press the Stop [■] button.
5. Press the Play [▶] button to start playback.

Selecting a Group during Playback (Search Mode)

This section explains how to select MP3 groups by number.

- 1**



During playback, press the [SEARCH] button.
The display blinks.
- 2**

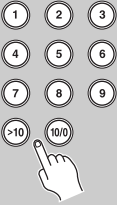



Use the number buttons to enter the group number.
Enter the numbers in order from left-to-right. For example, to enter group number 25, press [>10], [2], and [5].
The specified group name appears on the display.
You can alternatively select the group with the Previous and Next [J<<] / [>>I] buttons or the [◀]/[▶] buttons.
- 3**



Press the [ENTER] button.
The playback starts with the first track of the selected group.

Displaying MP3 Information

You can display various information about the MP3 track currently playing, including ID3 tags such as title name, artist name, and album name.

- Remote Controller DISPLAY**
- 
- During playback, press the [DISPLAY] button repeatedly to display the following MP3 information.**
- DISPLAY**
- 

Elapsed track time: The length of time that the current track has been playing (default display).

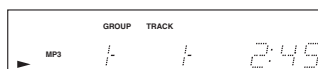

Track name: Name of the current track.



Group (folder) name: Name of the current group (folder).

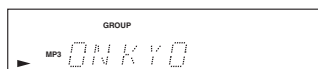

Title name: Title of the current track (if ID3 tag present). When there is no ID3 tag, “TITLE-NO DATA” is displayed.



Artist name: Name of the artist (if ID3 tag present).

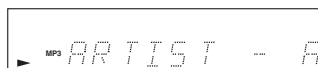

Album name: Name of the album (if ID3 tag present).

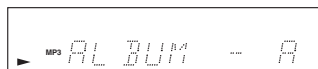

Sampling rate and bit rate: Sampling rate and bit rate of the current track.

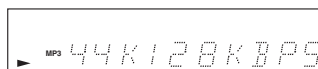

Example of display for MP3 CD.

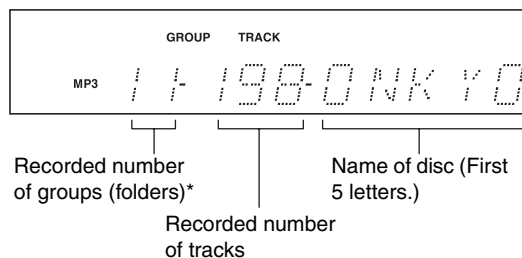

* Folders (directories) are referred to as *groups*.

Notes:

- To display the disc name, press the [DISPLAY] button while playback is stopped.
- If a track or group name contains any characters that cannot be displayed, an underscore will be displayed in place of those characters. Alternatively, you can set the DX-7355 so that names containing such characters are displayed as “TRACK n” or “GROUP n,” “n” being the track or group number (see “BAD NAME” on page 25).

Various Playback Modes

These are the available playback modes:

- 1-group playback (Only MP3 CDs)
- Random playback
- Memory playback

By pressing the [PLAY MODE] button, the indicator changes in this order: GROUP → MEMORY → RANDOM → No play mode display → ...

1-Group Playback (Only MP3 CDs)

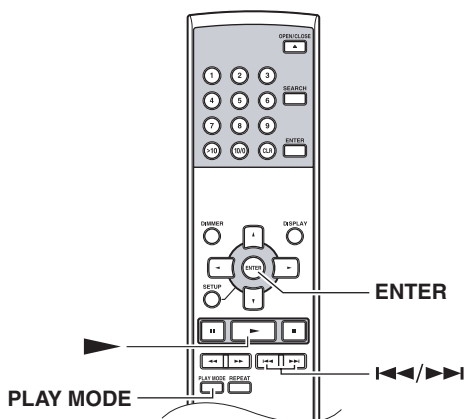

Normally, all of the MP3 tracks in all of the groups on the disc are played. In 1-group playback, only the MP3 tracks in the specified group are played.

1 Press the [PLAY MODE] button repeatedly until only the GROUP indicator is lit.

The diagram shows a hand pressing the PLAY MODE button. Below, the display shows 'GROUP' with a lit indicator and 'MP3 1-KARSHIMA'.

2 Use the Previous and Next [◀▶] / [▶▶] buttons or the [◀]/[▶] buttons to select the group. You can select any group that contains tracks.

Two diagrams illustrate button usage. The first shows the Previous and Next buttons being pressed. The second shows the Left and Right buttons being pressed. The word 'or' is placed between the two diagrams.

3 To start playback, press the [ENTER] or Play [▶] button. "1 GRP PLAY" on the display appears, then the playback starts with the first track of the selected group.

Two diagrams illustrate button usage. The first shows the ENTER button being pressed. The second shows the Play button being pressed. The word 'or' is placed between the two diagrams. Below, the display shows 'MP3 1 GRP PLAY'.

At the end of the last track of the selected group, the playback stops.

To Cancel 1-Group Playback

- Press the Stop [■] button to stop the playback.
- 1-group playback is cancelled when the disc is ejected.

Random Playback

In random playback, all of the tracks on the disc are played in random order.

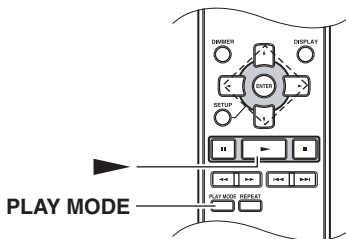

1 While playback is stopped, press the [PLAY MODE] button repeatedly until the RANDOM indicator appears.

The diagram shows a hand pressing the PLAY MODE button. Below, the display shows 'RANDOM' with a lit indicator and '1247:27'.

2 To start random playback, press the Play [▶] button.

The diagram shows a hand pressing the Play button. Below, the display shows '6' and '0:01'.

Track currently playing

To Cancel Random Playback

- Stop the playback, then press the [PLAY MODE] button to change the playback mode. The RANDOM indicator disappears, and random playback is cancelled.
- Random playback is cancelled when the disc is ejected.

Memory Playback (For Audio CDs)

In memory playback, you can create a playlist of up to 25 tracks.

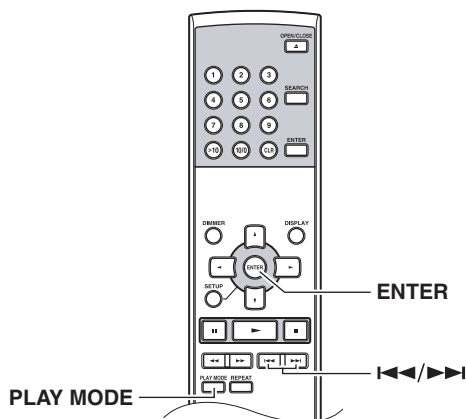

Memory playback can be set only when the playback is stopped.

1



Press the [PLAY MODE] button repeatedly until the MEMORY indicator appears.

MEMORY indicator



2

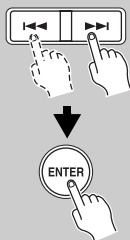

Use the Previous and Next [◀◀] / [▶▶] buttons to select the first track you want to add to the playlist, and then press [ENTER] button.

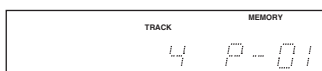

Track to be added Total time of playlist to the playlist

Repeat this step to add additional tracks to the playlist.

You can alternatively use the number buttons on the remote controller to select tracks instead of the Previous and Next [◀◀] / [▶▶] and the [ENTER] buttons.

To Remove Tracks from the Playlist

Press the [CLR] button. Each press removes the last track from the playlist.

Notes:

- If the total playing time is more than 99 minutes and 59 seconds, “- -:--” is displayed.
- You can add up to 25 tracks to the playlist. If you try to add more, the message “MEM FULL” appears.

To Change the Display

While the memory setting operations, press the [DISPLAY] button to change the display information as follows: Total playback time of the memorized tracks → Memory number → Current playback time of the selected track

3



To start memory playback, press the [ENTER] button.



Track currently playing

The memory playback starts.

- You can alternatively start playback with the Play [▶] button.

To Select Other Tracks During Memory Playback

Use the Previous and Next [◀◀] / [▶▶] buttons.

To Check What's on the Playlist

While playback is stopped, use the Fast Reverse and Fast Forward [◀◀] / [▶▶] buttons to scroll through the playlist.

To Remove Tracks from the Playlist

- While memory playback is stopped, press the [CLR] button. Each press removes the last track from the playlist.
- The playlist is deleted on changing the playback mode (press the [PLAY MODE] button after stopping the playback).

To Cancel Memory Playback







- Stop the playback, then press the [PLAY MODE] button to change the playback mode. The MEMORY indicator disappears, and memory playback is cancelled.
- Memory playback is cancelled when the disc is ejected.

Various Playback Modes—Continued

Memory Playback (For MP3 CDs)







Memory Playback in Navigation Mode

Memory playback can be set only when the playback is stopped.

1 	Press the [PLAY MODE] button repeatedly until the MEMORY indicator appears.
2 	Press the [▼] button. The DX-7355 enters Navigation mode and “ROOT” appears on the display.
3 	Press the [▼] button. The first group name in ROOT appears on the display.
4 	Use the [◀]/[▶] buttons to select other groups and tracks at the same level. Groups that don't contain tracks or subgroups can't be selected. Repeat steps 3 and 4 to select the tracks and subgroups in that group.
5 	Press the [ENTER] button. The first track is memorized in the playlist.
6 	Use the [▲]/[▼]/[◀]/[▶] buttons to continue selecting the memory track. To move up a level, press the [▲] button. To continue selecting the memory track, repeat steps 4 and 5. To memorize other tracks of the same group in the playlist, use the [◀]/[▶] buttons to select tracks, then press the [ENTER] button.
7 	Press the Play [▶] button. Memory playback starts. • You can also start playback with the [ENTER] button.

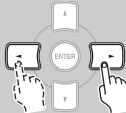
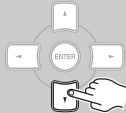
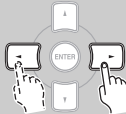
Memory Playback in All Group Mode

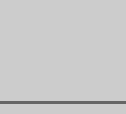
To Change the Display

1 	Press the [PLAY MODE] button repeatedly until the MEMORY indicator appears.
2 	Press the [▲] button. The DX-7355 enters All Group mode and “1-” appears on the display.
3 	Use the [◀]/[▶] buttons to select the group.
4 	Press the [▼] button.
5 	Use the [◀]/[▶] buttons to select the track.
6 	Press the [ENTER] button. The first track is memorized in the playlist.
7 	Press the [▲] button, then repeat steps 3 to 6. To memorize other tracks of the same group in the playlist, repeat steps 5 to 6.
8 	Press the Play [▶] button. Memory playback starts. • You can also start playback with the [ENTER] button.

To Change the Display

While the memory setting operations, press the [DISPLAY] button to change the display information as follows:

Track name → Group name → Memory number

Repeat Playback

In repeat playback, you can play an entire CD repeatedly, play one track repeatedly, or combine it with memory playback to play the playlist repeatedly, or random playback to play all of the tracks on the disc in random order repeatedly.

For MP3 CDs, you can combine repeat playback with 1-group playback to play all of the tracks in a specified group repeatedly.

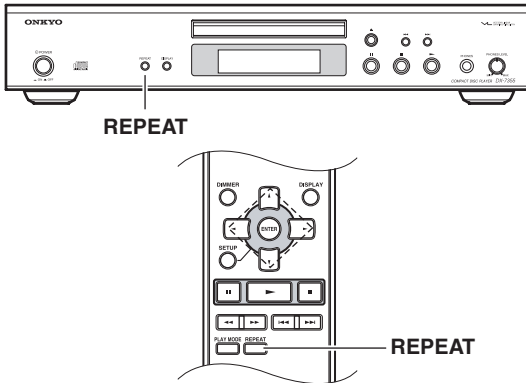

Remote Controller

Press the [REPEAT] button repeatedly until the “REPEAT ALL” or “REPEAT 1” indicator appears.

indicator

Repeat-1 playback can't be combined with memory playback, random playback, or 1-group playback.

To Cancel Repeat Playback

- Press the [REPEAT] button repeatedly until the “REPEAT OFF” indicator appears. (The “↻” indicator disappears.)
- Repeat playback is cancelled when the disc is ejected.

Setting for MP3

Setting MP3 Preferences

With the MP3 preferences, you can change the way MP3 track information is displayed and the way MP3 CDs are played.

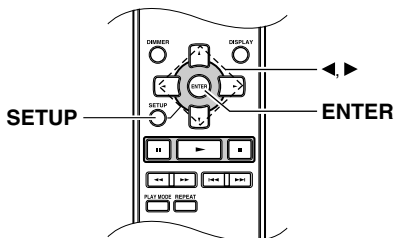

The MP3 preferences can be set only when playback is stopped.

1 Press the [SETUP] button.

2 Use the [◀]/[▶] buttons to select the preference you want to change.

MP3 DISC NAME

The preferences are explained in the next column.

3 Press the [ENTER] button.

4 Use the [◀]/[▶] buttons to select the preference's options.

To cancel the procedure at any point, press the [SETUP] button.

5 Press the [ENTER] button.

When the preference has been set, “COMPLETE” appears on the display.

Preferences

Below, the name of each preference is followed by its options in parentheses, with the default option in bold.

DISC NAME (DISPLAY/NOT)

This preference determines whether or not the disc name is displayed when an MP3 disc is read.

TRACK NAME (SCROLL/NOT)

This preference determines whether or not the track name scrolls across the display when an MP3 track is selected.

In Navigation mode (see page 18), the track name scrolls across the display regardless of this setting.

GRP NAME (SCROLL/NOT)

This preference determines whether or not the group (folder) name scrolls across the display when an MP3 group (folder) is selected.

In Navigation mode (see page 18), the group name scrolls across the display regardless of this setting.

BAD NAME (REPLACE/NOT)

This preference determines whether or not track and group names that contain undisplayable characters are replaced with “TRACK n” or “GROUP n,” “n” being the track or group number. When set to NOT, displayable characters are displayed and underscores are used in place of any undisplayable characters.

For ID3 tags, underscores are used in place of undisplayable characters regardless of this preference.

Note:

Track and group names are scrolled in Navigation mode (page 18) regardless of the TRACK NAME and GRP NAME preferences.

ID3 VER.1 (READ/NOT READ)

This preference determines whether or not version 1.0/1.1 tags are read and displayed. When set to NOT READ, version 1.0/1.1 tags will not be displayed.

ID3 VER.2 (READ/NOT READ)

This preference determines whether or not version 2.2/2.3/2.4 tags are read and displayed. When set to NOT READ, version 2.2/2.3/2.4 ID3 tags will not be displayed.

CD EXTRA (AUDIO/MP3)

This preference applies to CD Extra discs and determines whether music in the audio session or MP3 tracks in the data session are played.

JOLIET (USE SVD/ISO9660)

This preference applies to MP3 discs in Joliet format and determines whether the DX-7355 reads the SVD data or treats the disc as an ISO 9660 disc. Normally, this preference doesn't need to be changed.

SVD (Supplementary Volume Descriptor) supports long track and group names and characters other than letters and numbers.

HIDE NUM (DISABLE/ENABLE)

This preference determines whether or not the numbers at the beginning of track and group names are hidden.

When you create an MP3 CD on a personal computer, you cannot normally determine the playback order of the tracks. However, if you number the MP3 tracks in order, starting with 01, 02, 03, and so on, they will play in that order. If you don't want these numbers to appear on the display, choose ENABLE.

The following table shows a few examples of numbered track and group names and how they will appear with the DISABLE and ENABLE options.

Track/group name	DISABLE	ENABLE
01 POPS	01 POPS	POPS
10-ROCK	10-ROCK	ROCK
16_JAZZ	16_JAZZ	JAZZ
21TH CENTURY	21TH CENTURY	21TH CENTURY
05-07-20 ALBUM	05-07-20 ALBUM	ALBUM

STOP KEY (ALL GRP/NAVIGATION/DISABLE)

This preference determines how the Stop [■] button on the DX-7355 works.

When the ALL GRP option is selected, pressing the stop [■] button once selects All Group mode and pressing and holding it for 2 seconds selects Navigation mode.

When the NAVIGATION option is selected, pressing the stop [■] button once selects Navigation mode and pressing and holding it for 2 seconds selects All Group mode.

When the DISABLE option is selected, DX-7355 does not enter Navigation or All Group mode by pressing the Stop [■] button.

Troubleshooting

If you have any trouble using the DX-7355, look for a solution in this section.

If you can't resolve the issue yourself, try resetting the DX-7355 before contacting your Onkyo dealer.

To reset the DX-7355 to its factory defaults, turn it on and, while holding down the [▶▶] button, press the [REPEAT] button. "CLEAR" will appear on the display.

Note that resetting the DX-7355 will delete your custom settings.

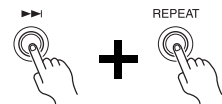

Power

Can't turn on the DX-7355.

- Make sure that the power cord is properly plugged into the wall outlet (page 15).
- Unplug the power cord from the wall outlet, wait five seconds or more, then plug it in again.

Audio

There's no sound.

- The DX-7355 is not connected properly. Check all connections and correct as necessary.
- The wrong input source is selected on your amplifier. Check your amplifier's input source setting. Refer to your amplifier's manual.

CD

Can't play a CD.

- The disc is upside down. Load the disc with the label-side facing up (page 16).
- The disc is dirty. Remove the disc and clean it (page 11).
- Condensation has formed inside the DX-7355. Remove the disc and leave the DX-7355 turned on for several hours until the condensation has evaporated.
- The disc is nonstandard. See "Supported Discs" on page 11.
- The CD-R/RW disc is nonstandard. See "Supported Discs" on page 11.

CD playback skips.

- Install the DX-7355 somewhere free of vibration.
- The disc is dirty. Remove the disc and clean it (page 12).
- The disc is very scratched. Replace the disc.

Can't enter track numbers for memory playback.

- No such track on the CD. Enter another number (page 22).

It takes a long time to locate certain tracks.

- The disc is dirty. Remove the disc and clean it (page 12).
- The disc is very scratched. Replace the disc.

SETUP

Can't find a SETUP menu in need.

- If any track has been selected even when the DX-7355 is stopped, you must place it into the full stop state by pressing the [■] button before you can view all the SETUP menus.

Remote Controller

The remote controller does not work.

- There are no batteries in the remote controller. Install new batteries (page 10).
- The batteries are flat. Replace with new batteries (page 10).
- The batteries are installed incorrectly. Check the batteries and correct as necessary (page 10).
- You're not pointing the remote controller at the DX-7355's remote sensor. Point the remote controller at the DX-7355's remote sensor (page 10).
- You're too far away from the DX-7355. Use the remote controller closer to the DX-7355 (page 10). The remote controller has a range of approximately 5 meters (16 ft.).
- A strong light source is interfering with the DX-7355's remote sensor. Make sure that the DX-7355 is not subjected to direct sunshine or inverter-type fluorescent lights. Relocate if necessary.
- If the DX-7355 is installed in a cabinet with colored glass doors, the remote controller may not work reliably when the doors are closed. Open the doors, or use a cabinet without colored glass.

Troubleshooting—Continued

RI does not work.

- There's no RCA/phono analog audio connection. To use **RI** you must make an analog audio connection (RCA/phono) between the DX-7355 and your Onkyo AV receiver, even if they are connected digitally.

The DX-7355 contains a microcomputer for signal processing and control functions. In very rare situations, severe interference, noise from an external source, or static electricity may cause it to lockup. In the unlikely event that this should happen, unplug the power cord, wait at least 10 seconds, and then plug it again.

Onkyo is not responsible for damages (such as CD rental fees) due to unsuccessful recordings caused by the unit's malfunction. Before you record important data, make sure that the material will be recorded correctly.

Specifications

Signal readout:	Optical non-contact
Frequency response:	4 Hz–20 kHz
SN ratio:	106 dB
Audio dynamic range:	100 dB
THD (total harmonic distortion):	0.0029%
Audio output	
Digital optical:	–22.5 dBm
Audio output/Impedance	
Digital coaxial:	0.5 V (p-p), 75 Ω
Audio output/Impedance	
Analog:	2.0 V (rms), 600 Ω
Power supply:	AC 120/220–240 V, 50/60 Hz AC 220–230 V, 50/60 Hz
Power consumption:	Worldwide model: 15 W Others: 14 W
Dimensions (W × H × D):	435 × 81 × 315 mm
Weight:	4.4 kg
Operation condition	
Temperature, humidity:	5–35 °C, 5–85% (no condensation)
Supported discs:	CD, CD-R, CD-RW, MP3 (Discs that have not been properly finalized may only be partially playable or not playable at all.)

Specifications and features are subject to change without notice.

ONKYO CORPORATION

Sales & Product Planning Div. : 2-1, Nisshin-cho, Neyagawa-shi, OSAKA 572-8540, JAPAN
Tel: 072-831-8023 Fax: 072-831-8124

ONKYO U.S.A. CORPORATION

18 Park Way, Upper Saddle River, N.J. 07458, U.S.A.
Tel: 201-785-2600 Fax: 201-785-2650 <http://www.us.onkyo.com/>

ONKYO EUROPE ELECTRONICS GmbH

Liegnitzerstrasse 6, 82194 Groebenzell, GERMANY
Tel: +49-8142-4401-0 Fax: +49-8142-4401-555 <http://www.eu.onkyo.com/>

ONKYO EUROPE UK Office

Suite 1, Gregories Court, Gregories Road, Beaconsfield, Buckinghamshire, HP9 1HQ
UNITED KINGDOM Tel: +44-(0)1494-681515 Fax: +44(0)-1494-680452

ONKYO CHINA LIMITED

Units 2102-2107, Metroplaza Tower I, 223 Hing Fong Road, Kwai Chung,
N.T., HONG KONG Tel: 852-2429-3118 Fax: 852-2428-9039
<http://www.ch.onkyo.com/>



Y0702-2

SN 29344396A

(C) Copyright 2007 ONKYO CORPORATION Japan. All rights reserved.



* 2 9 3 4 4 3 9 6 A *