



The EE440 is a E-ink based electronic shelf label with a screen size of 4.4" and with 802.15.4 based wireless communication.

Preliminary Specifications Manual

All information subject to change without notice.

Document History

Model Number:	EE440	Specification Number:	
Edition:	0.1	Original Spec Number:	
Date:	2015		

Copyright 2015 Opticon. All rights reserved.

This manual may not, in whole or in part, be copied, photocopied, reproduced, translated or converted to any electronic or machine readable form without prior written consent of Opticon.

Limited Warranty and Disclaimers

PLEASE READ THIS MANUAL CAREFULLY BEFORE INSTALLING OR USING THE PRODUCT.

Serial Number

A serial number appears on all Opticon products. This official registration number is directly related to the device purchased. Do not remove the serial number from your Opticon device. Removing the serial number voids the warranty.

Warranty

Unless otherwise agreed in a written contract, all Opticon products are warranted against defects in materials and workmanship for two years after purchase. Opticon will repair or, at its option, replace products that are defective in materials or workmanship with proper use during the warranty period. Opticon is not liable for damages caused by modifications made by a customer. In such cases, standard repair charges will apply. If a product is returned under warranty and no defect is found, standard repair charges will apply. Opticon assumes no liability for any direct, indirect, consequential or incidental damages arising out of use or inability to use both the hardware and software, even if Opticon has been informed about the possibility of such damages.

Packaging

The packing materials are recyclable. We recommend that you save all packing material to use should you need to transport your scanner or send it for service. Damage caused by improper packaging during shipment is not covered by the warranty.

Trademarks

Trademarks used are the property of their respective owners.

Opticon Inc. and Opticon Sensors Europe B.V. are wholly owned subsidiaries of OPTOELECTRONICS Co., Ltd., 12-17, Tsukagoshi 4-chome, Warabi-shi, Saitama, Japan 335-0002. TEL +81-(0) 48-446-1183; FAX +81-(0) 48-446-1184

SUPPORT

USA

Phone: 800-636-0090

Email: support@opticonusa.com

Web: www.opticonusa.com

Europe

Email: support@opticon.com

Web: www.opticon.com

Contents

1. Abstract	5
2. Overview	5
3. Physical Features	6
3.1. Dimensions	6
3.2. Weight.....	6
4. Environmental Specifications	6
4.1. Operating Temperature and Humidity.....	6
4.2. Storage Temperature and Humidity.....	6
4.3. Static Electricity	6
4.4. Drop resistance.	6
4.5. Dust and Drip Proof.....	7
5. Controls	8
6. Electrical Specifications	8
6.1. Electrical Characteristics	8
6.2. Battery.....	9
7. Specifications	9
7.1. Protocol.....	9
7.1.1. The physical layer	9
7.1.2. The medium access control layer	9
7.2. Security	9
8. Labeling	10
8.1. Product label	10
8.2. Shipment box labels	12
9. Accessories	13
10. Packaging Specifications	13
10.1. Individual Packaging Specification.....	13
10.2. Collective Packaging Specification	13
11. Regulatory Compliance	14
11.1. Product Safety.....	14
11.2. EMC	14
11.3. WEEE.....	15
11.4. RoHS	15
12. Safety	16
12.1. Shock	16
12.2. Temperature Conditions	16

12.3. Foreign Materials..... 16

12.4. Battery..... 16

12.5. Disposal 16

12.6. Other 16

13. Mechanical Drawing 17

Table of Figures

Figure 1: Dimensions6

Figure 2: product label 10

Figure 3: product label dimensions 11

Figure 4: shipment box labels 12

Figure 6: Individual packaging 13

Figure 7: Collective packaging 13

Figure 8: Mechanical drawing 17

1. Abstract

This manual provides specifications for the EE440 electronic shelf label (hereafter referred to as “ESL”).

2. Overview

The EE440 is an E-ink based ESL with a 2.4GHz radio for data communication. This product uses Direct Sequence Spread Spectrum RF technology that allows for an ultra-low power consumption combined with a reduced sensitivity to background noise. That means less interference by other radios that operate in the 2.4GHz band. The radio protocol that is used is based on the IEEE 802.15.4 standard that specifies the physical layer and media access control for low-rate wireless personal area networks. The protocol is entirely implemented, except for some small changes that have all to do with the connection protocol to a base station. When the base station is not available the EE440 switches to a non-802.15.4 standard to lower the power. That is especially meaningful when the EE440 is not being used for a prolonged period of time (e.g. during shipping)

The EE440 is intended to be operated in combination with a base station such as the EBS30 which can control a large number of EE440 and other types of ESL of the same family such as EE201.

3. Physical Features

3.1. Dimensions

(WxHxD): 106.52 mm x 90.86 mm x 18.20 mm

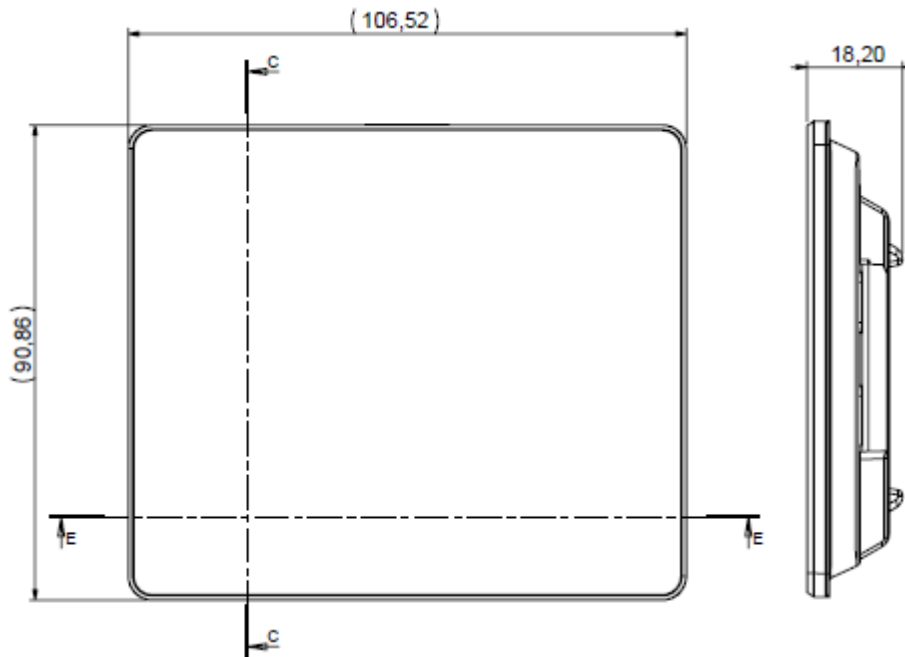

Figure 1: Dimensions

3.2. Weight

XXX g (including batteries)

4. Environmental Specifications

4.1. Operating Temperature and Humidity

Temperature: 10 to 50° C

Humidity: 20% to 85% RH

4.2. Storage Temperature and Humidity

Temperature: -20 to 60° C

Humidity: 20% to 85% RH

4.3. Static Electricity

Air discharge: ± 8 kV MAX (No malfunction)
 ± 15 kV MAX (No destruction)

Contact discharge: ± 4 kV MAX (No malfunction)
 ± 8 kV MAX (No destruction)

4.4. Drop resistance.

There will be no sign of decreased performance after the following drop test:

Drop the ESL from 1.8 M above the concrete floor (6 sides, 3 times each).

Scratches or discoloration of the casing do not decrease product performance.

4.5. Dust and Drip Proof

IP54

Dust Prevention

Level	Details
5	Ingress of dust is not entirely prevented, but it must not enter in sufficient quantity to interfere with the satisfactory operation of the equipment; complete protection against contact.

Water Prevention

Level	Details
4	Water splashing against the enclosure from any direction shall have no harmful effect.

5. Controls

Items	Specifications		Remarks
CPU	Type	8051 core 8-bit MCU	
	Internal flash ROM	256KB	
	Internal RAM	8 KB	
	Clock frequency	32 MHz	
LCD	Active area	W 89.6 x H 67.2 mm	
	Number of dots	W 400 x H 300	
	Dot pitch	113 Horizontal 113 Vertical	Dots per Inch
Radio	Modulation	DSSS	
	Frequency	2405 - 2480 MHz	Globally approved 2.4GHz band.
	Baud rate	250 Kbits / second	

6. Electrical Specifications

6.1. Electrical Characteristics

Conditions: Operating voltage 3.0V unless otherwise specified

Parameter	Typ	Unit	Remarks
Operating voltage	3.0	V	2x Alkaline AAA size battery (Reference: Panasonic LR03XWA)
Sleep current	<1	uA	When the transmitter and receiver are idle
Poll time	20	seconds	See below

The ESL is in sleep mode almost the entire time. The device wakes up at regular intervals (called the poll time) and it then transmits a poll request to the base station. When the base station has no data to send, it just acknowledges the poll after which the ESL immediately goes back to sleep. The poll rate is configurable and is set to 20 seconds by default. A higher poll rate will decrease the power consumption but will increase the response time.

6.2. Battery

The power is supplied to the ESL by two replaceable Alkaline AAA size batteries.

7. Specifications

Parameter	Min	Typ	Max	Unit	Remarks
Receiver sensitivity		-97	-89	dBm	Over the entire temp. and operating voltage range
Nominal output power	-3	4.5	7	dBm	
Frequency	2405		2480	MHz	Over the entire temp. and operating voltage range
Transfer rate		250Kbit/s			
RSSI range		100		dB	Signal strength indication that can be reported to the base station

7.1. Protocol

Modified 802.15.4 (Physical layer and Media Access Control layer).

7.1.1. The physical layer

The physical layer (PHY) provides the data transmission service, as well as the interface to the physical layer management entity, which offers access to every layer management function and maintains a database of information on related personal area networks. Thus, the PHY manages the physical RF transceiver and performs channel selection and energy and signal management functions. It operates on the above mentioned frequency band. The PHY layer is 100% compliant and is based on direct sequence spread spectrum (DSSS) technique with a transfer rate of 250 kbit/s.

7.1.2. The medium access control layer

The medium access control (MAC) layer enables the transmission of MAC frames through the use of the physical channel. Besides the data service, it offers a management interface and itself manages access to the physical channel. It also controls frame validation, guarantees time slots and handles node associations. Finally, it offers hook points for secure services. The EE440 does not make use of the optional network beaconing, instead it used a polling mechanism to increase power efficiency. Some changes are made to the standard to allow for more efficient data frames and better power efficiency, especially when nodes are not connected to a base station.

7.2. Security

The 802.15.4 standard 128-bit AES encryption is supported. A secure method for key management is implemented as well. The encryption is optional though and can be configured via the base station. By default the radio traffic is unencrypted.

8. Labeling

8.1. Product label

The product label is affixed to the back side of EE440 as shown below.



Figure 2: product label

The barcode shows the product serial number.

The 'B' is followed by 10 hexadecimal digits. These correspond to the MAC address of the unit.

Material: Base + laminate protection against wear.

Base: PP film, thickness 80µm, backing with glue.

Laminate: PET film, clear, thickness 50µm.

The dimensions of the product label are as follows:



Figure 3: product label dimensions

8.2. Shipment box labels

The shipment box labels are made from plain paper and are meant to show the regulatory information on the shipment box as well as the quantity in the box. The label design is shown below. The labels are 150mm*95mm and are made from plain paper with adhesive backing.

TO BE DETERMINED

XXX

Figure 4: shipment box labels

Label A shows the PO number, the Quantity in the box and the serial number range, all encoded in barcodes as shown. In case there are two or less missing serial numbers, only label A is required. In case there are more than 2 missing serial numbers missing, label B is required to show the rest of the missing serial numbers.

9. Accessories

TBD XXX

10. Packaging Specifications

10.1. Individual Packaging Specification

TBD XXX

Figure 5: Individual packaging

10.2. Collective Packaging Specification

TBD XXX

Figure 6: Collective packaging

Note: The “RO” mark labeled on the package tray or package box guarantees that the applicable product has passed our test of RoHS restrictions compliance (the restriction of the use of certain hazardous substances in electrical and electronic equipment, 2002/95 EC). However, this document does **not** have any legal weight in the European Union.

11. Regulatory Compliance

11.1. Product Safety

EN60950-1:2001

IEC60950-1:2001

11.2. EMC

EN55022

EN55024

Federal Communications Commission (FCC) Statement

15.21

You are cautioned that changes or modifications not expressly approved by the part responsible for compliance could void the user's authority to operate the equipment.

15.105(b)

This equipment has been tested and found to comply with the limits for a Class B digital device, pursuant to part 15 of the FCC rules. These limits are designed to provide reasonable protection against harmful interference in a residential installation.

This equipment generates uses and can radiate radio frequency energy and, if not installed and used in accordance with the instructions, may cause harmful interference to radio communications. However, there is no guarantee that interference will not occur in a particular installation. If this equipment does cause harmful interference to radio or television reception, which can be determined by turning the equipment off and on, the user is encouraged to try to correct the interference by one or more of the following measures:

- Reorient or relocate the receiving antenna.
- Increase the separation between the equipment and receiver.
- Connect the equipment into an outlet on a circuit different from that to which the receiver is connected.
- Consult the dealer or an experienced radio/TV technician for help.

This device complies with part 15 of the FCC Rules. Operation is subject to the following two conditions:

- 1) this device may not cause interference and
- 2) this device must accept any interference, including interference that may cause undesired operation of the device.

RF Radiation Exposure Statement:

1. This Transmitter must not be co-located or operating in conjunction with any other antenna or transmitter.
2. This equipment complies with FCC RF radiation exposure limits set forth for an uncontrolled environment. This equipment should be installed and operated with a minimum distance of 20 centimeters between the radiator and your body.

11.3. WEEE

Waste Electrical and Electronics Equipment Directive, 2012/19/EU.



Following information is only for EU-member states:

The use of the symbol indicates that this product may not be treated as household waste. By ensuring this product is disposed of correctly, you will help prevent potential negative consequences for the environment and human health, which could otherwise be caused by inappropriate waste handling of this product. For more detailed information about recycling of this product, please contact your local city office, your household waste disposal service or the shop where you purchased the product.

11.4. RoHS

RoHS: The restriction of the use of certain hazardous substances in electrical and electronic equipment, 2011/65 EC.

12. Safety

Handle this product carefully. Do not deliberately subject it to any of the following.

12.1. Shock

Do not throw or drop the ESL.

Do not place heavy objects on the ESL.

12.2. Temperature Conditions

Do not use the ESL at temperatures outside the specified range.

Do not pour boiling water on the ESL.

Do not throw the ESL into the fire.

Do not leave the ESL on the dashboard of a car.

12.3. Foreign Materials

Do not immerse the ESL in liquids.

Do not subject the ESL to chemicals.

12.4. Battery

Replace the battery when its lifetime has expired. The typical lifetime of a set of batteries is 4 years when using quality alkaline batteries. Treat the batteries as chemical waste and dispose of them according to local regulations.

CAUTION
RISK OF EXPLOSION IF BATTERY IS REPLACED
BY AN INCORRECT TYPE.
DISPOSE OF USED BATTERIES ACCORDING
TO THE INSTRUCTIONS

12.5. Disposal

When discarding the product, treat it as chemical waste and dispose of it according to local regulations.

12.6. Other

Do not disassemble this product, other than opening the battery compartment to exchange the batteries.

The ESL may be damaged by high voltage discharges.

13. Mechanical Drawing

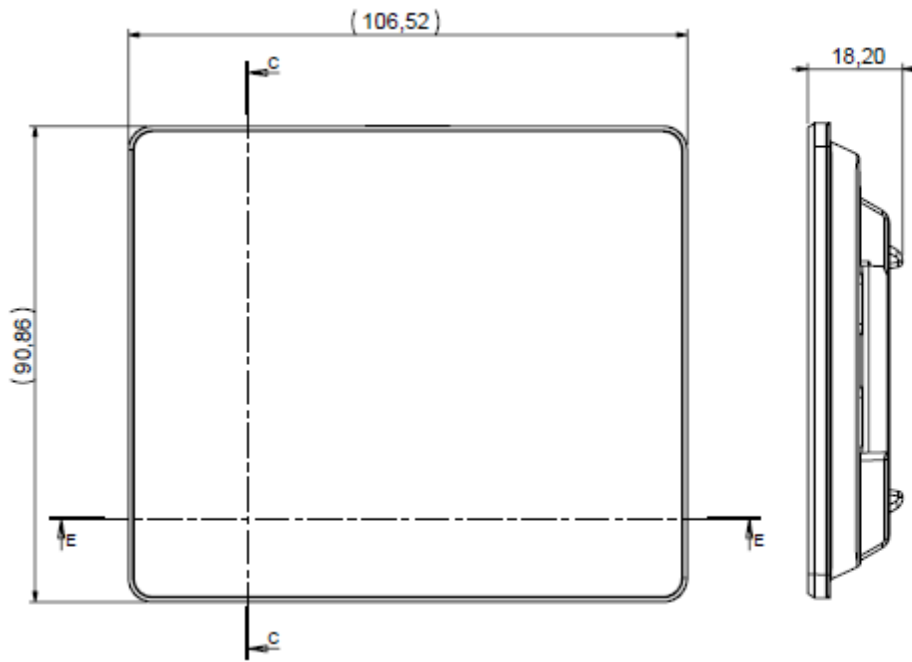

Figure 7: Mechanical drawing