

OPTICON

Data Collector with GPS & Bluetooth

OPL-9815



The OPL-9815 is a laser data collector featuring GPS (Global Positioning System) feature, Bluetooth 2.1 communication and time stamp functionality.

Specifications Manual

All information subject to change without notice.

Document History

Model Number:	OPL-9815	Specification Number:	
Edition:	1	Original Spec Number:	
Date:	2012-02-18		

Copyright 2012 Opticon. All rights reserved.

This manual may not, in whole or in part, be copied, photocopied, reproduced, translated or converted to any electronic or machine readable form without prior written consent of Opticon.

Limited Warranty and Disclaimers

PLEASE READ THIS MANUAL CAREFULLY BEFORE INSTALLING OR USING THE PRODUCT.

Serial Number

A serial number appears on all Opticon products. This official registration number is directly related to the device purchased. Do not remove the serial number from your Opticon device. Removing the serial number voids the warranty.

Warranty

Unless otherwise agreed in a written contract, all Opticon products are warranted against defects in materials and workmanship for two years after purchase. Opticon will repair or, at its option, replace products that are defective in materials or workmanship with proper use during the warranty period. Opticon is not liable for damages caused by modifications made by a customer. In such cases, standard repair charges will apply. If a product is returned under warranty and no defect is found, standard repair charges will apply. Opticon assumes no liability for any direct, indirect, consequential or incidental damages arising out of use or inability to use both the hardware and software, even if Opticon has been informed about the possibility of such damages.

Packaging

The packing materials are recyclable. We recommend that you save all packing material to use should you need to transport your data collector or send it for service. Damage caused by improper packaging during shipment is not covered by the warranty.

Trademarks

Trademarks used are the property of their respective owners.

Opticon Inc. and Opticon Sensors Europe B.V. are wholly owned subsidiaries of OPTOELECTRONICS Co., Ltd., 12-17, Tsukagoshi 4-chome, Warabi-shi, Saitama, Japan 335-0002. TEL +81-(0) 48-446-1183; FAX +81-(0) 48-446-1184

SUPPORT

USA

Phone: 800-636-0090

Email: support@opticonusa.com

Web: www.opticonusa.com

Europe

Email: support@opticon.com

Web: www.opticon.com

Contents

1. Abstract	5
2. Overview	5
3. Physical Features	5
3.1. Dimensions	5
3.2. Weight.....	5
3.3. Color	5
4. Environmental Specifications	6
4.1. Operating Temperature and Humidity.....	6
4.2. Storage Temperature and Humidity.....	6
4.3. IP (dust/water) rating	6
4.4. Drop	6
4.5. Ambient Light Immunity	6
4.6. Supported symbologies:.....	7
5. Controls	8
6. Electrical Specifications	8
6.1. Main Battery	8
6.2. Battery Operating Time and Charging Time (TBD).....	8
7. Optical Specifications	9
7.1. Laser Scan Specifications	9
8. Technical Specifications	9
8.1. Print Contrast Signal (PCS).....	9
8.2. Minimum Resolution	9
8.3. Scan Area and Resolution	10
8.4. Pitch, Skew, and Tilt.....	11
8.5. Curvature	14
9. Interface Specifications	14
9.1. Bluetooth	14
9.2. Infrared Transmission (IrDA)	15
9.3. GPS	15
10. Serial Number	16
10.1.1. Detailed drawing	17
10.1.2. Serial number.....	17
10.1.3. Manufacturing date	18
10.2. White box label.....	18
11. Packaging Specifications	19

11.1. Individual Packaging Specification (TBD)	19
11.2. Accessory Specification (TBD)	20
11.3. Collective Packaging Specification	20
12. Durability	21
12.1. Drop Test (without packaging).....	21
12.2. Dust and Drip Proof.....	21
13. Reliability	21
14. Regulatory Compliance.....	22
14.1. Laser Safety	22
14.2. Certifications.....	22
14.3. RoHS	22
14.4. State of California: Perchlorate Best Management Practices.....	23
15. Safety precautions.....	24
15.1. Shock	24
15.2. Temperature Conditions	24
15.3. Foreign Materials.....	24
15.4. Other	24
16. Mechanical Drawing	25
17. Detailed view.....	26

Table of Figures

Figure 1: Ambient Light Immunity.....	6
Figure 2: Depth of field	10
Figure 3: Pitch	11
Figure 4: Skew and dead zone	12
Figure 5: Tilt angle	13
Figure 6: Curvature.....	14
Figure 7: Name plate and serial number	16
Figure 8: Individual packaging	19
Figure 9: Collective packaging	20
Figure 10: Drop test.....	21
Figure 11: Mechanical drawing	25

1. Abstract

This manual provides specifications for the OPL-9815 barcode data collector.

2. Overview

The OPL-9815 is a barcode data collector that contains a compact laser module.

This data collector offers efficient scanning performance that is suitable for various business environments and is able to store scanned data and data configured via keyboard input.

Bluetooth ver 2.1 is one of the communication options for this device allowing it to wirelessly connect to many peripherals like printers, smart phones and tablets. The supported profiles are SPP (Serial port profiles) and HID (keyboard emulation).

Infra-red is another communication option of the OPL-9815. Stored data can be sent out via an IrDA Ver.1.2-compliant infra-red transceiver. For easy connection to a computer, Opticon sells several cradles that can be used to receive the infra-red transmission and convert that to a standard RS232 or USB signal that can be connected to any computer. On top of the communication features that the cradles can offer, they can also be used to charge the battery inside the data collector.

The OPL-9815 also has a GPS (Global Positioning System) feature and clock function. Those extra features of the OPL-9815 make it possible to add location data and a time stamp to scanned barcode data. Additional to the OPL 9813, this model features a backlit display and a keyboard with 18 keys.

The OPL-9815 can use a variety of cradles:

- CRD 9723 single-bay cradle (1 x charging, 1 x communication)
- CRD 9723 multi-bay cradle (5 x charging, 1 x communication)
- CRD 9723 multi-bay cradle (5 x charging, 5 x communication)
- CRD 9722 single-bay cradle (1 x charging, no communication)
- CRD 9726 Single-bay cradle with land-line modem
- CRD 9727 Single-bay cradle with GSM modem

Use a dedicated C-language-based development tool to develop applications for the OPL-9815.

3. Physical Features

3.1. Dimensions

W 44.0 mm x D 22.0 mm x H 140.0 mm

3.2. Weight

115 g (max.), excluding the lithium-ion battery

3.3. Color

Black

4. Environmental Specifications

4.1. Operating Temperature and Humidity

Temperature: 0 to 40° C

Humidity: 20 to 85%

4.2. Storage Temperature and Humidity

Temperature: -20 to 60° C

Humidity: 20 to 90%

4.3. IP (dust/water) rating

IP 54

4.4. Drop

1.5m on concrete

4.5. Ambient Light Immunity

Decoding performance is guaranteed when the range of illumination on a barcode surface is between zero and the following values:

Incandescent light	3,000 lx
Fluorescent light	3,000 lx
Sunlight	50,000 lx

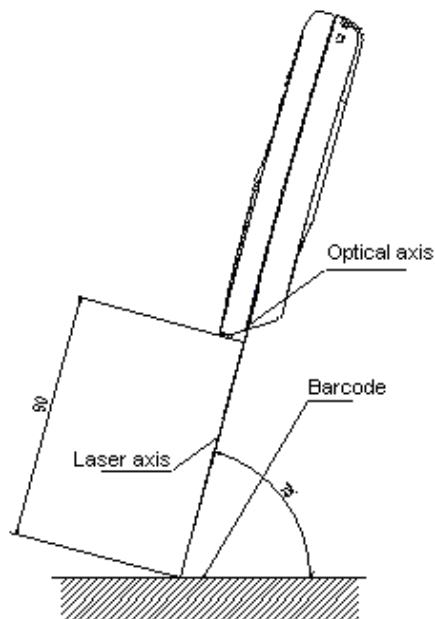

Figure 1: Ambient Light Immunity

Conditions

Barcode Sample: OPTOELECTRONICS Test Sample

PCS:	0.9
Resolution:	0.25 mm
Symbology:	8-digit Code 39
Quiet Zone:	10 mm
N/W Ratio:	1:2.5

Direct light or specular reflection light from a source should be prevented from entering the acceptance area.

Note: α , β and γ respectively represent pitch, skew and tilt. Please see section 8 for how these values are defined.

4.6. Supported symbologies:**Linear (1D)**

JAN/UPC/EAN, incl. add-on
Codabar/NW-7
Code 11
Code 39
Code 93
Code 128
GS1-128 (EAN-128)
GS1 Databar (RSS)
IATA
Industrial 2of5
Interleaved 2of5
ISBN-ISSN
Matrix 2of5
MSI/Plessey
S-Code
Telepen
Tri-Optic
UK/Plessey

Postal

Chinese Post
Korean Postal Authority Code

2D

Composite Codes
MicroPDF417*
PDF417*

* Requires use of an external library.

5. Controls

Item	Specifications		Remarks
Controls	MPU	32-bit microprocessor	
	Built-in ROM	512 KB	
	Built-in RAM	64 KB	
External memory	Flash ROM	1 MB	
	SRAM	512 KB	
Display	LCD	Monochrome	
	Dots	112 x 64	
	Backlight	Yes	
	Scanning indicators	Tricolor LED and buzzer	
Keyboard	Keys	Shift, backspace, Clear, dot, Enter, up, down and trigger. 0~9 numeric keys	
Scanning	Laser wavelength/output	650 nm / 1mW or less	
	Scanning frequency	100 times/s	
Clock	Real time clock	Supports year, month, date, hour, minute and seconds (leap year supported)	
Buzzer	Loudness	75 dBA or higher	

6. Electrical Specifications

6.1. Main Battery

The main battery is a lithium-ion secondary battery.

Nominal capacity: 1100 mAh

Battery charging time: Approximately 3 hours

6.2. Battery Operating Time and Charging Time (TBD)

Parameter	Specifications	Notes
Backup battery	3 mAh manganese dioxide battery	
Current consumption	1 mA or less (on standby)	
	160 mA or less (when operating)	GPS, Bluetooth and backlight on.
Usable time	50 hours or more (not using GPS)	1 scan/5s
	10 hours or more (using GPS)	
Data hold time	72 hours or more	After main battery discharged

Note: Battery life may be shorter than specified above when the quality of the battery pack is degraded.

7. Optical Specifications

7.1. Laser Scan Specifications

Parameter	Specification	Unit
Light-emitting element	Red laser diode	—
Emission wavelength	650 ±10 (25° C)	nm
Light output	1.0 or less	mW
Scanning method	Bi-directional vibration mirror	—
Scanning speed	100 ±20	scans/s
Scan angle	Scan angle: 54 ±5	°
	Read angle: 44 (Min)	°
Resolution	0.127 and above	Mm

Note: Refer to chapter 8, “Technical Specifications,” to read about scanning performance.

8. Technical Specifications

The conditions for technical specifications are as follows, unless otherwise specified in each section.

Conditions

Ambient temperature and humidity:	Room temperature (5 to 35° C) Room humidity (45% to 85% RH)
Ambient light:	500 to 900 lx
Background:	Barcode = black
	Space = white
	Margin = white
	Background of label = black

8.1. Print Contrast Signal (PCS)

PCS = 0.45 or higher (over 70% of reflectivity of space and quiet zone).

Scanning performance may decline if dirt or scratches mark the optical window. Keep the optical window clean.

8.2. Minimum Resolution

0.15 mm

8.3. Scan Area and Resolution

8.3.1. Depth of Field

The depth of field is measured from the edge of the data collector. The scanning range is within the circular arc centered on the scan origin.

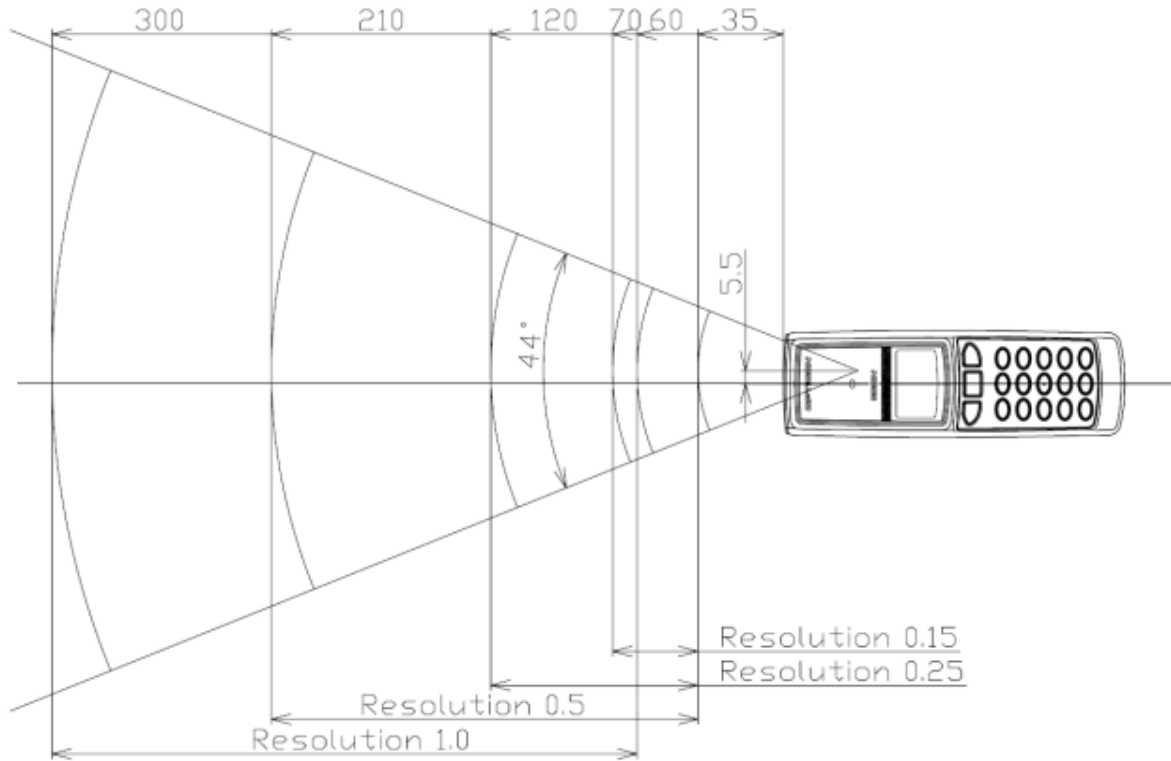

Figure 2: Depth of field

Symbology	Resolution (mm)	Decode Depth (mm)	PCS
Code 39	1.0	60–300	0.9
Code 39	0.5	35–210	0.9
Code 39	0.25	35–120	0.9
Code 39	0.15	35–70	0.9

Conditions

Barcode Sample: OPTOELECTRONICS Test Sample

- NW ratio: 1:2.5
- Angle: $\alpha = 0^\circ, \beta = 15^\circ, \gamma = 0^\circ$
- Curvature: $R = \infty$

Resolution	Symbology	PCS	Quiet Zone	Digit
1.0 mm	Code 39	0.9	25 mm	1
0.5 mm	Code 39	0.9	18 mm	3
0.25 mm	Code 39	0.9	10 mm	8
0.15 mm	Code 39	0.9	7 mm	10

Note: dirt or scratches on the mask will degrade scanning performance. Always handle the data collector carefully.

8.4. Pitch, Skew, and Tilt

8.4.1. Pitch Angle

$\alpha = \pm 25^\circ$

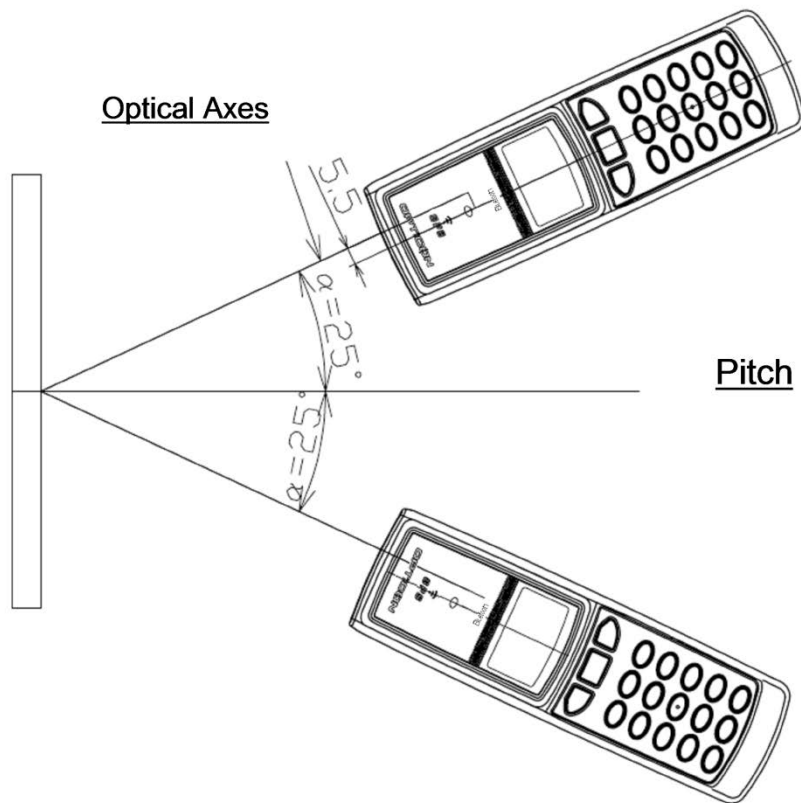

Figure 3: Pitch

Conditions

Barcode Sample: OPTOELECTRONICS Test Sample

Distance: 90 mm from the edge of the data collector

Label: **Pitch, Skew Angle**

PCS = 0.9, Resolution = 0.25 mm, Symbology = 9-digit Code 39,
Quiet Zone = 10 mm, N/W Ratio = 1:2.5

Dead Zone, Tilt Angle

PCS = 0.9, Resolution = 0.26 mm, Symbology = 13-digit JAN, Quiet Zone = 10 mm

Angle: Curvature: $R = \infty$, Skew Angle = $\beta + 15^\circ$ (for measuring Pitch Angle and Tilt Angle)

8.4.2. Skew Angle and Dead Zone

Skew angle: $\beta = \pm 50^\circ$ (Excluding dead zone)

Dead zone: $\beta = \pm 8^\circ$ (There are some areas in which decoding fails due to specular reflection)

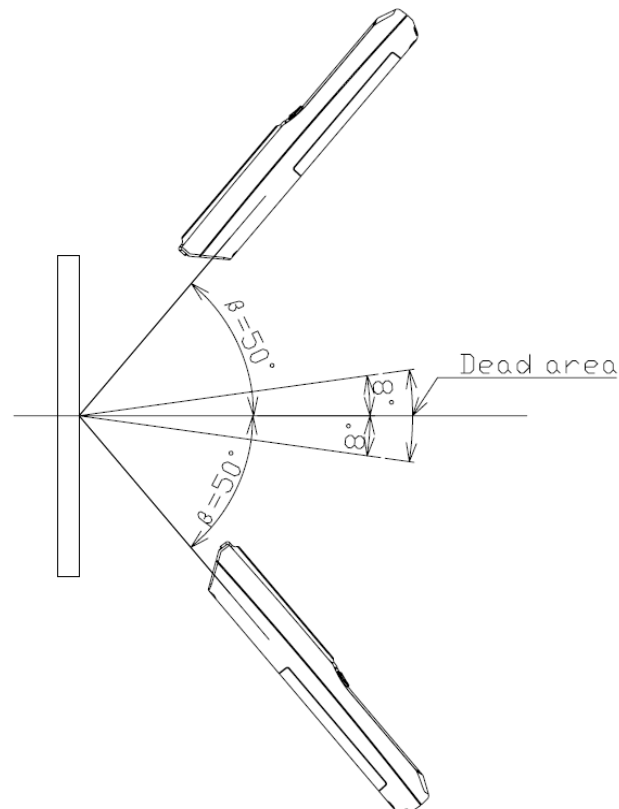

Figure 4: Skew and dead zone

Conditions

Barcode Sample: OPTOELECTRONICS Test Sample

Distance: 90 mm from the edge of the data collector

Label: **Pitch, Skew Angle**

PCS = 0.9, Resolution = 0.25 mm, Symbology = 9-digit Code 39,
Quiet Zone = 10 mm, N/W Ratio = 1:2.5

Dead Zone, Tilt Angle

PCS = 0.9, Resolution = 0.26 mm, Symbology = 13-digit JAN, Quiet Zone = 10 mm

Angle: Curvature: $R = \infty$, Skew Angle = $\beta + 15^\circ$ (for measuring Pitch Angle and Tilt Angle)

8.4.3. Tilt Angle

$\gamma = \pm 20^\circ$

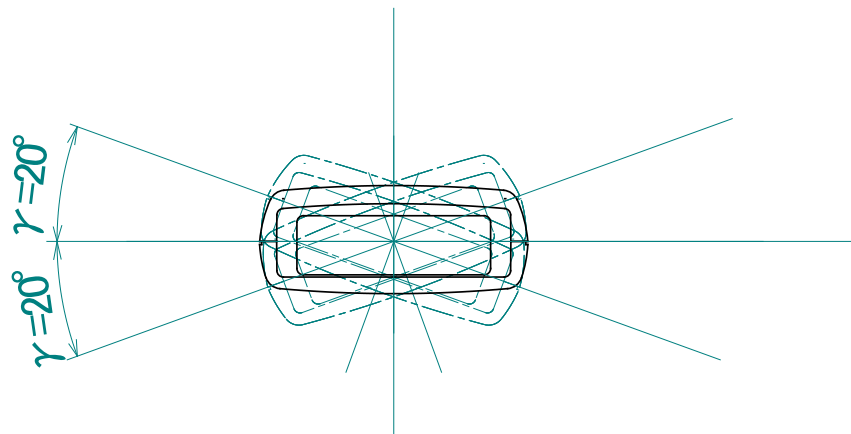

Figure 5: Tilt angle

Conditions

Barcode Sample: OPTOELECTRONICS Test Sample

Distance: 90 mm from the edge of the data collector

Label: **Pitch, Skew Angle**

PCS = 0.9, Resolution = 0.25 mm, Symbology = 9-digit Code 39,
Quiet Zone = 10 mm, N/W Ratio = 1:2.5

Dead Zone, Tilt Angle

PCS = 0.9, Resolution = 0.26 mm, Symbology = 13-digit JAN, Quiet Zone = 10 mm

Angle: Curvature: $R = \infty$, Skew Angle = $\beta + 15^\circ$ (for measuring Pitch Angle and Tilt Angle)

8.5. Curvature

With 8-digit JAN/UPC/EAN barcodes, decoding performance is guaranteed when $R \geq 20$ mm.

With 13-digit JAN/UPC/EAN barcodes, decoding performance is guaranteed when $R \geq 25$ mm.

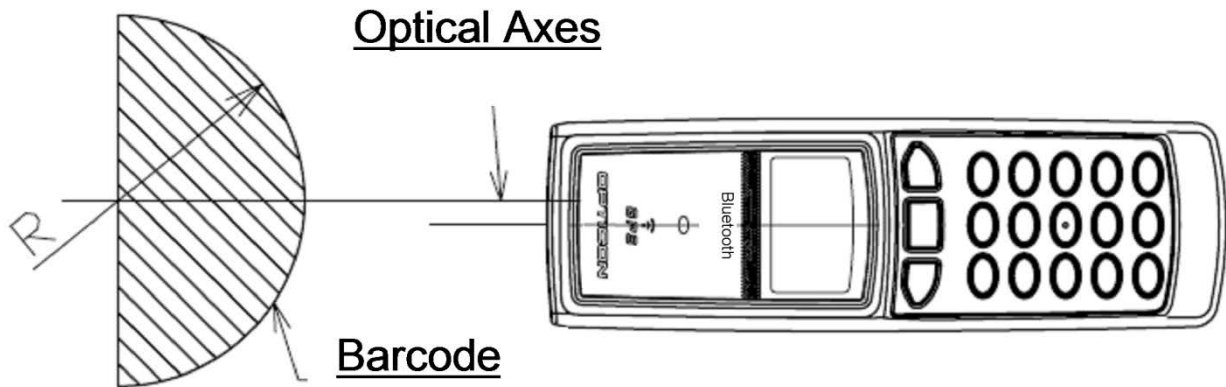

Figure 6: Curvature

Conditions

Barcode Sample: OPTOELECTRONICS Test Sample

PCS = 0.9, Resolution = 0.26 mm, Quiet Zone = 10 mm

Distance: 90 mm from the edge of the data collector

Angle: Skew Angle $\beta = +15^\circ$

The scanning range will vary according to the depth of field.

9. Interface Specifications

9.1. Bluetooth

9.1.1. Module

The OPL-9815 is equipped with a low power fully certified Bluetooth module.

9.1.2. Specifications

Bluetooth standard: 2.1

High speed UART interface

Supported profiles: SPP (serial port profile) and HID (keyboard emulation)

9.2. Infrared Transmission (IrDA)

9.2.1. Specifications

The dedicated cradle enables the OPL-9815 to perform infrared transmission of data with IrDA Ver1.2 low power specification.

9.2.2. Transmission Speed

Default transmission speed is set at 115.2 kbps. However, you can easily change the transmission rate to 57.6 kbps, 38.4 kbps, 19.2 kbps, 9600 bps, 4800 bps, or 2400 bps.

9.3. GPS

9.3.1. Module

The OPL-9815 is equipped with a GPS (Global Positioning System) module plus a compact patch antenna (15 mm X 15 mm)

9.3.2. Receiving Frequency

1575.42MHz (L1 C/A Code)

9.3.3. Receiving Channel

66 channels (max)

9.3.4. Sensitivity

Acquisition -148 dBm

Tracking -165 dBm

9.3.5. Time to First Fix (TTFF)

TTFF is the time required for a GPS receiver to acquire satellite signals and navigation data, and calculate a position. It may differ depending on the environmental conditions, such as the number of satellites, obstacles between the satellite and the GPS antenna, or multipath conditions.

- 1 second: Hot Start
- 33 seconds: Warm Start
- 35 seconds: Cold Start

9.3.6. Position-fix Accuracy

3.0 m 2D-RMS

Values may differ, depending on the environmental conditions.

9.3.7. Baud Rate

4800 bps to 115200. Default is 9600 baud

9.3.8. Protocol

NMEA-0183 (Default)

10. Labeling

10.1. Serial Number

Below is the product label with serial number.

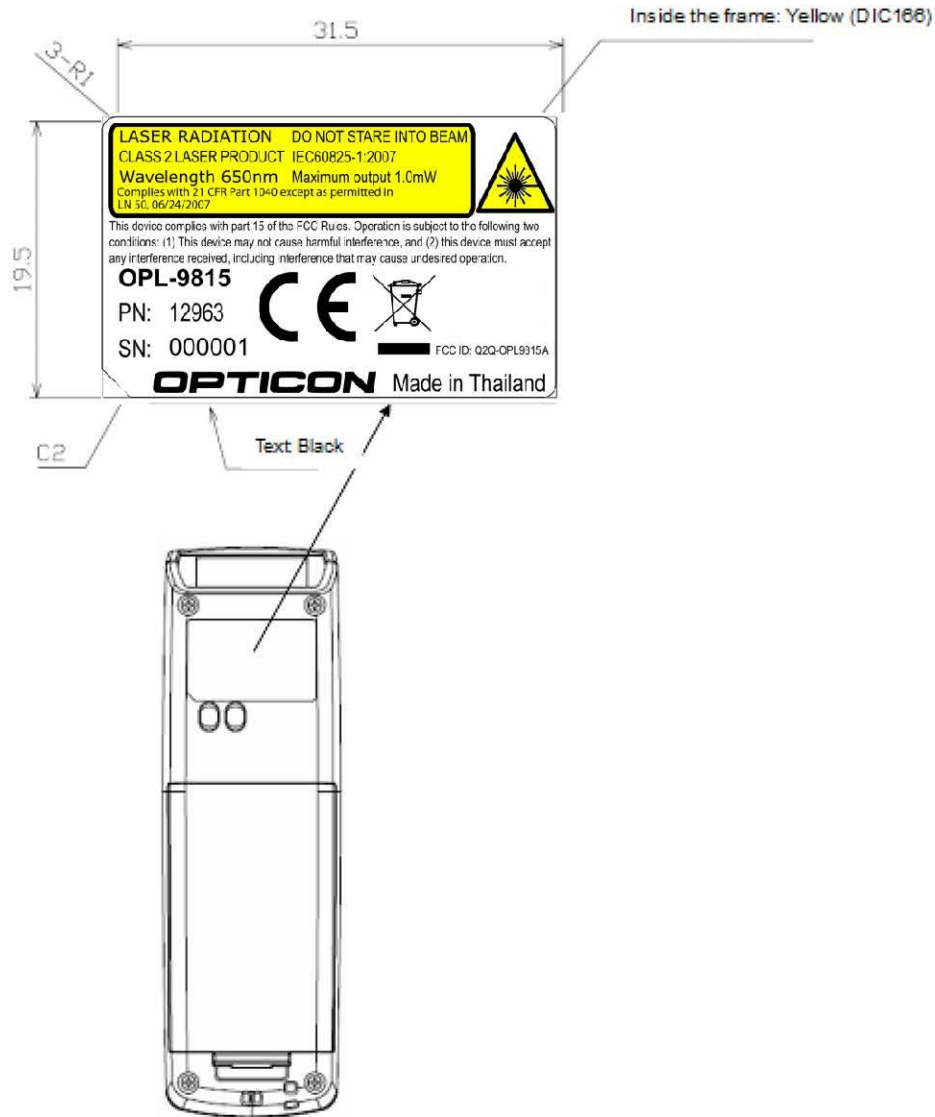

Figure 7: Name plate and serial number

Material: Base + laminate protection against wear.
Base: PP film, thickness 80µm, backing with glue.
Laminate: PET film, clear, thickness 50µm.

10.1.1. Detailed drawing

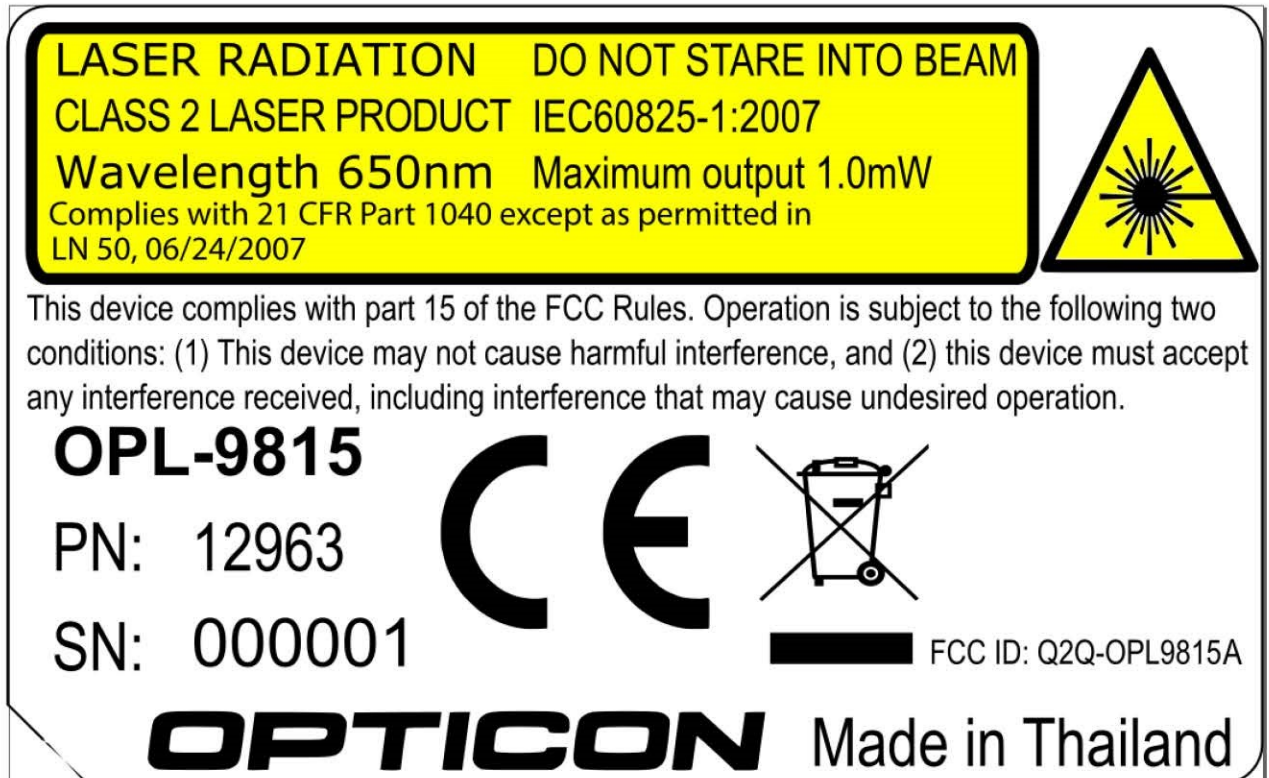

Figure 8: Name plate and serial number details

10.1.2. Serial number

Bar code: Standard Code 39 plus human readable text printed below the bar code.

Bar code height: 4mm

Bar code data: The serial number. This should match that of the OPL-9815 in the box.

The serial number consists out of 6 digits, starts with 000001 and is incremented with one every unit that is produced.

During production, the serial number is also programmed inside the OPL's non volatile memory. API functions are available to retrieve that number.

10.1.3. Manufacturing date

Manufactured: XXXXXXXX 20xx

The manufacturing date has to be printed on the label and will be the month (starting with an upper case character, rest lower case characters) followed by the year of production. So e.g. August 2014

10.2. White box label

Size is 70mm x 25mm with a tolerance of ± 2 mm

Example labels: Avery 3421 or similar.

Label material: Paper, white, with permanent adhesive backing.

Bar codes:

Article number: Standard code 39 + human readable text

Bar code data: 12963

Serial number: Standard code 39 + human readable text

Bar code data: The serial number. This should match that of the OPL-9815



11. Packaging Specifications

11.1. Individual Packaging Specification (TBD)

Put the data collector in a protective foam bag and place it in an individual packing box, then place the accessories into the box. Close the box and affix a label to the side of the box. Size of the package after assembly: 247 (W) x 113 (D) x 38 (H) mm

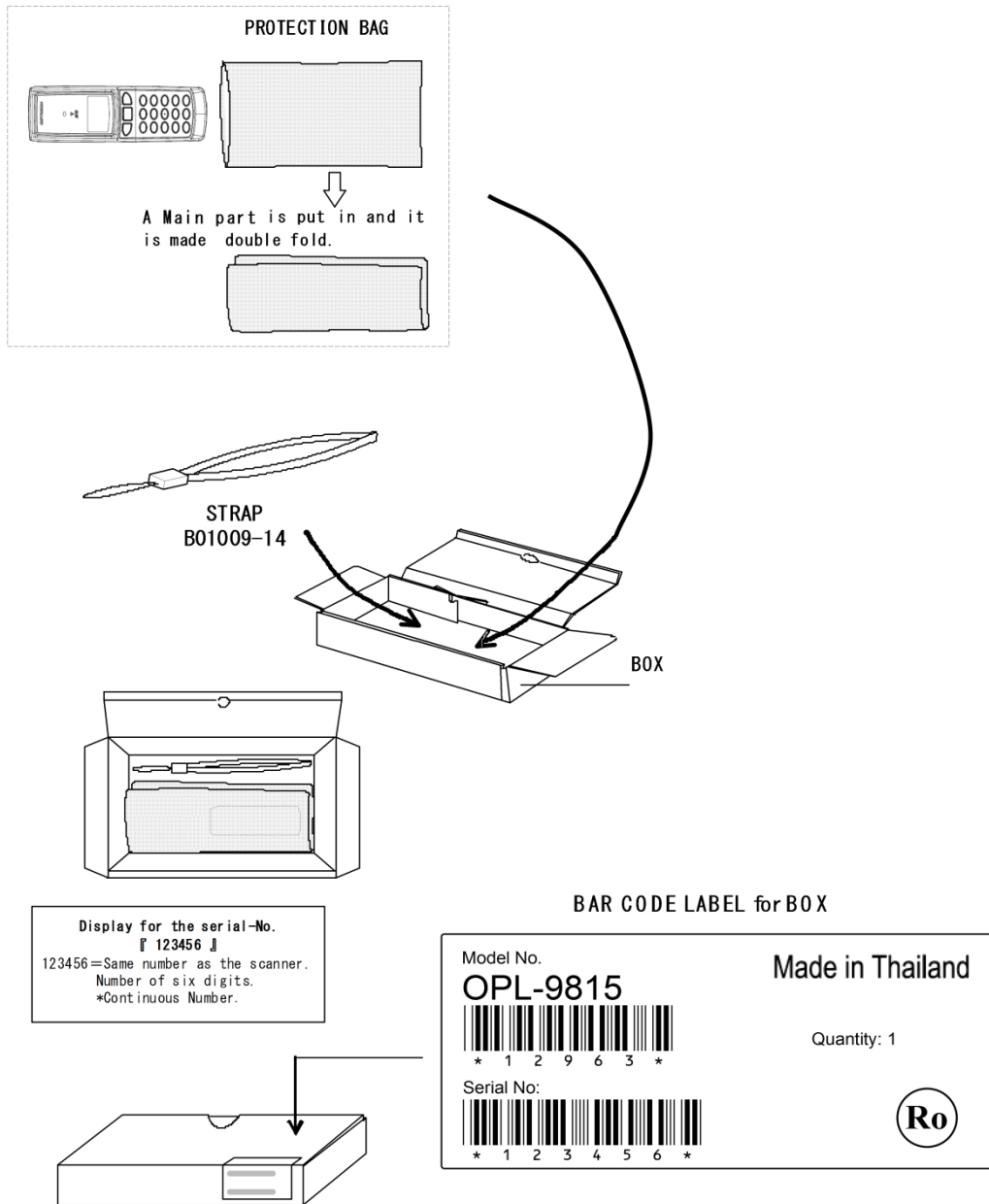

Do not fold at the Bar-Code Position,
when stick the Label on to the Corner of Box.

Figure 9: Individual packaging

11.2. Accessory Specification (TBD)

These accessories are enclosed in an individual package:

- 1 hand strap

11.3. Collective Packaging Specification

Put 150 individually packaged data collectors in a collective packing box. The box can hold 162 boxes, so there will be some empty space in the shipping box. That should be filled by packing peanuts.

Dimensions: 615 mm (W) by 520 mm (D) by 277 mm (H).

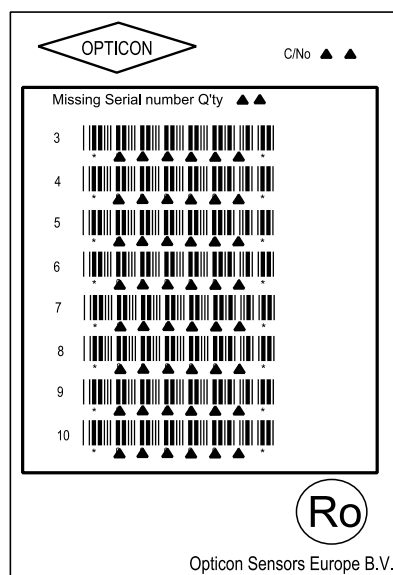
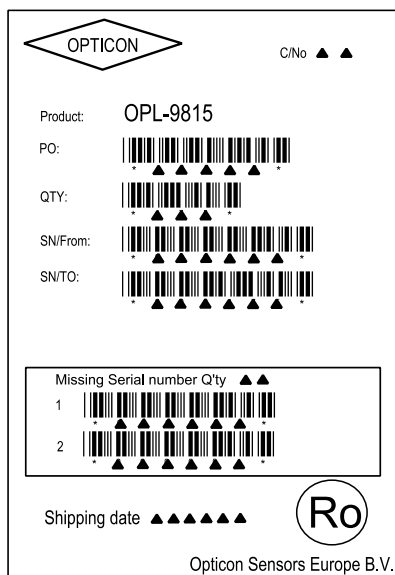
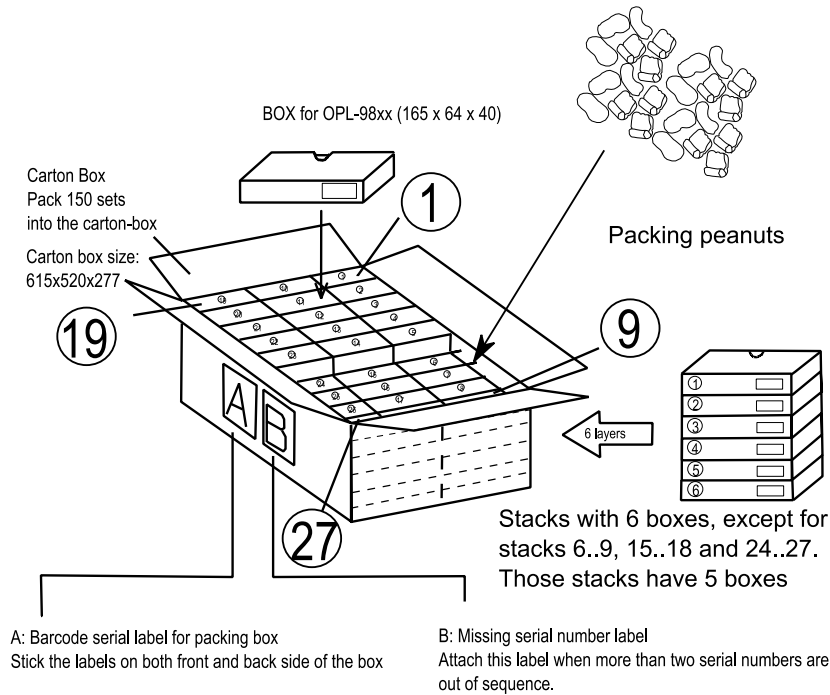

Figure 10: Collective packaging

Note: The “RO” mark labeled on the package tray or package box guarantees that the applicable product has passed our test of RoHS restrictions compliance (the restriction of the use of certain hazardous substances in electrical and electronic equipment, 2002/95 EC). However, this document does **not** have any legal weight in the European Union.

12. Durability

12.1. Drop Test (without packaging)

No malfunction occurred after the following drop test.

Drop Test: Drop the data collector from a height of 150 cm onto a concrete floor. Each side of the data collector impacted the floor three times.

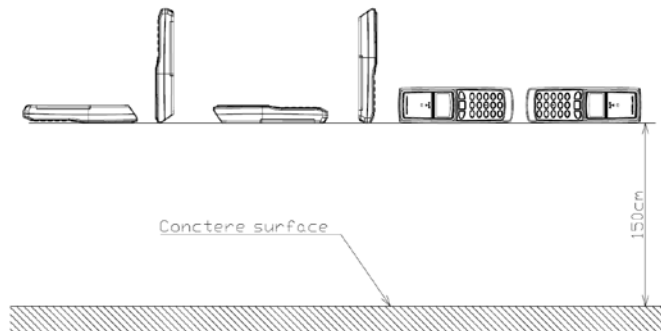

Figure 11: Drop test

12.2. Dust and Drip Proof

IEC IP54

Dust Prevention

Level	Details
5	Ingress of dust is not entirely prevented, but it must not enter in sufficient quantity to interfere with the satisfactory operation of the equipment; complete protection against contact.

Water Prevention

Level	Details
4	Water splashing against the enclosure from any direction shall have no harmful effect.

13. Reliability

MTBF (Mean Time Between Failures) of this product is 10,000 hours.

14. Regulatory Compliance

14.1. Laser Safety

The data collector emits a laser beam.

IEC 825-1/EN 60825-1: Laser class 2

FDA CDRH Laser class II. Complies with 21 CFR 1040.10 and 1040.11 except for deviations pursuant to laser notice No. 50 dated June 24, 2007.

Class II laser devices are not considered to be hazardous when used for their intended purpose. Avoid staring into the laser beam.

14.2. Certifications

FCC Part 15 Subpart B Class B:

15.21

You are cautioned that changes or modifications not expressly approved by the part responsible for compliance could void the user's authority to operate the equipment.

15.105(b)

This equipment has been tested and found to comply with the limits for a Class B digital device, pursuant to part 15 of the FCC rules. These limits are designed to provide reasonable protection against harmful interference in a residential installation. This equipment generates, uses and can radiate radio frequency energy and, if not installed and used in accordance with the instructions, may cause harmful interference to radio communications. However, there is no guarantee that interference will not occur in a particular installation. If this equipment does cause harmful interference to radio or television reception, which can be determined by turning the equipment off and on, the user is encouraged to try to correct the interference by one or more of the following measures:

- Reorient or relocate the receiving antenna.
- Increase the separation between the equipment and receiver.
- Connect the equipment into an outlet on a circuit different from that to which the receiver is connected.
- Consult the dealer or an experienced radio/TV technician for help.

This device complies with Part 15 of the FCC Rules. Operation is subject to the following two conditions:

- 1) This device may not cause harmful interference and
- 2) This device must accept any interference received, including interference that may cause undesired operation of the device.

14.3. RoHS

RoHS: The restriction of the use of certain hazardous substances in electrical and electronic equipment, 2011/65/EU.

14.4. State of California: Perchlorate Best Management Practices

The batteries on some Opticon products may contain Perchlorate. To comply with California Perchlorate Best Practice Regulations and the Law for the Promotion of Utilization of Recyclable Resources (Japan), products that may contain Perchlorate materials should be properly labeled on the exterior of all outer shipping packages and/or in locations that otherwise satisfy the California Perchlorate Best Management Practices.

15. Safety precautions

Handle this product carefully. Do not deliberately subject it to any of the following.

15.1. Shock

Do not throw or drop the data collector.

Do not drop or put heavy items on this product.

15.2. Temperature Conditions

Do not use the data collector at temperatures outside the specified range.

Do not use near heat sources such as radiators, heat registers, stoves, or other types of devices that produce heat.

Do not use in areas exposed to direct sunlight for long periods of time.

Do not pinch or forcibly bend the cable, especially at very low temperature.

15.3. Foreign Materials

Do not use the data collector near water or other liquids, as well as in extremely high humidity.

Do not immerse the data collector in liquids.

Do not use in dusty environments.

Do not subject the data collector to chemicals.

Do not insert foreign substances into the device.

15.4. Other

Do not attempt to disassemble, modify or update this device.

Do not use near microwaves, medical devices, or RF-emitting devices.

The data collector may be damaged by high voltage discharges.

CAUTION
RISK OF EXPLOSION IF BATTERY IS REPLACED
BY AN INCORRECT TYPE.
DISPOSE OF USED BATTERIES ACCORDING
TO THE INSTRUCTIONS

16. Mechanical Drawing

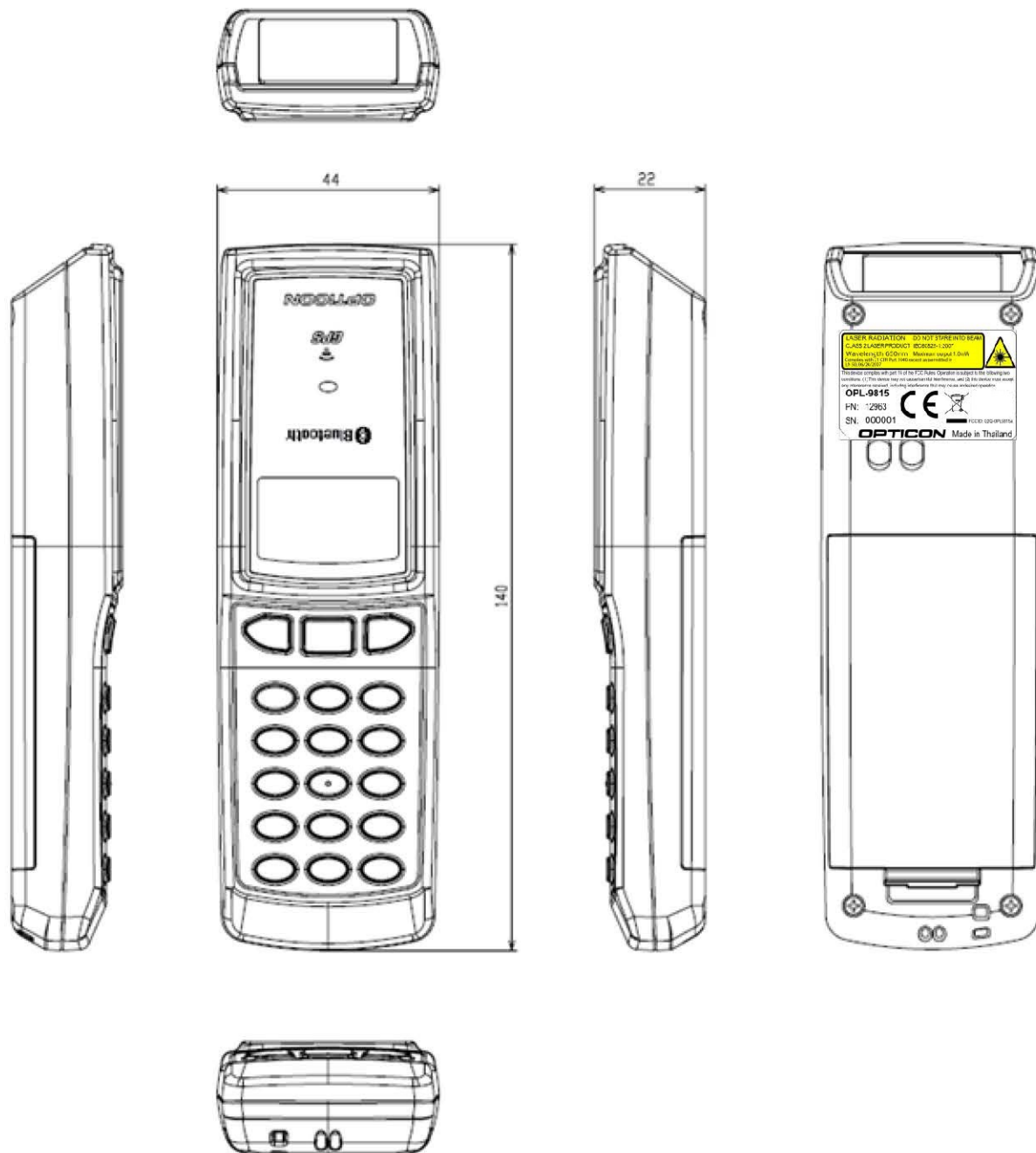
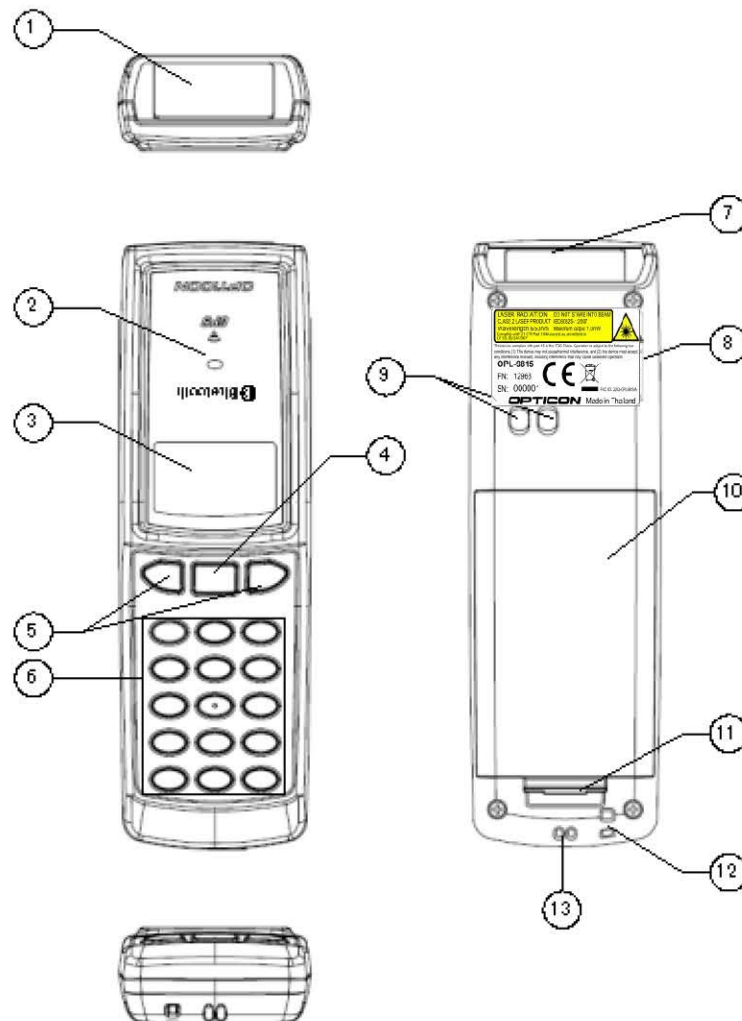

Figure 12: Mechanical drawing

17. Detailed view



No.	Items	Descriptions
1	Scanning window	Laser that reads barcodes is emitted from this opening.
2	LED Indicator	Indicates operational status.
3	LCD	Monochrome display
4	Trigger key	Press to scan barcodes
5	Up Down keys	Used when selecting items from a menu.
6	Operation keys (10)	Used for numerical input, backspace, Clear and Shift
7	Infra-red radiation	For infra-red communication with dedicated cradle
8	Label attaching position	Place for serial label
9	Terminal	Used to charge the OPL9815 by dedicated cradle
10	Battery cover	Remove when replacing the rechargeable battery
11	Battery cover lock	Used to lock / open the battery cover
12	Hand strap hole	Hole for attaching a hand strap
13	Buzzer hole	Hole for buzzer.