

ORECK[®] XL[®]

S I M P L Y A M A Z I N G[®]



USA: 1-800-989-3535
CANADA: 1-888-676-7325



WWW.ORECK.COM



VISIT ONE OF OUR OVER
450 STORE LOCATIONS

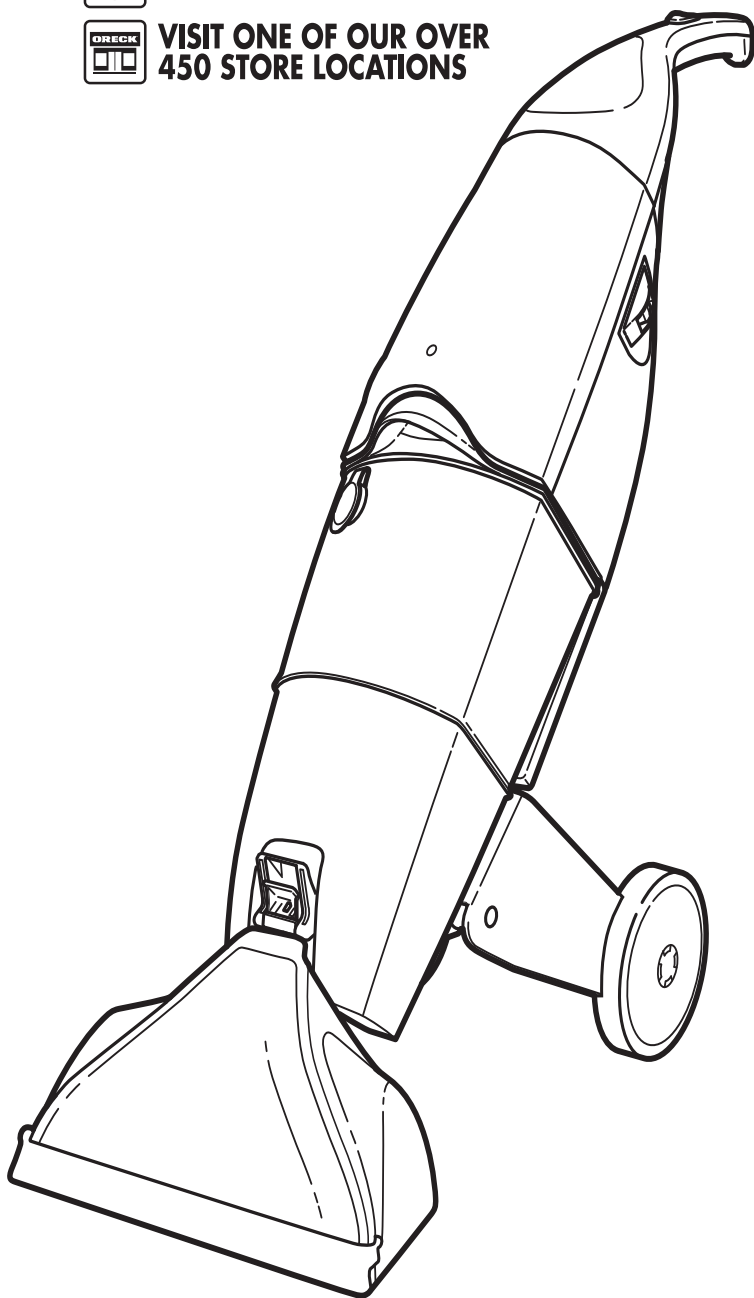

USER'S GUIDE
ORECK[®]
XL[®] SHIELD
Power Scrubber
M900

• **IMPORTANT!**
SAVE THIS BOOKLET!

Includes:

- Warranty
- Safety Warnings
- Parts List
- Operating Instructions
- Accessories List
- Trouble Diagnosis

BEFORE OPERATING CLEANER, READ ALL INSTRUCTIONS IN THIS MANUAL CAREFULLY.

Table of Contents

Maintenance and Customer Service, Polarized Plug Notice, Accessories & Replacement Parts, Important Safety Instructions	page	2
Warranty, Safety Precautions, Troubleshooting Guide	page	3
Figures	page	4
Parts Checklist, Features, To Assemble Cleaner	page	5
Servicing of Double-Insulated Appliances, A.L.C.I., To Set Up Cleaner, To Prepare Carpet, Operating Inst.	page	6
Operating Instructions	page	7
To Clean Carpet Cleaner, To Store Cleaner, Things To Do, To Replace Belt, To Clean Power Nozzle	page	8

Maintenance and Customer Service

Your ORECK STEEMER is a product of precise engineering. The motor bearings are permanently lubricated and should not be oiled. If you require additional information or have problems with your Oreck appliance, you may call ORECK CUSTOMER SERVICE at:

US: 1-800-989-3535 Canada: 1-888-676-7325

Please specify the model number and serial code number which can be found on the data label on the back of the unit.

Save your sales or purchase slip. Should your Oreck appliance require warranty service in the U.S.A., present this slip to the Authorized Service Center as your proof of purchase date or, in Canada, call customer service.

Accessories & Replacement Parts

All accessories and replacement parts are sold separately. To order, call our customer service group or visit our website. Please have you model number from the data label on the back of the unit.

ITEM	PART #
Full Release® Professional Spot & Stain PreCleaner	FRSS131
Full Release® Professional Carpet & Hard Floor Cleaner	40032-03
Full Release® Professional Upholstery Cleaner	40033-03
Allergen Control Kit with Spot & Stain Remover	FRC400
Oreck Full Release® Allergen Control Carpet Cleaner	40257-01
Motor Belt Replacement	53364-01
Squeegee Replacement	53360-01-438

Customer Service Hotline

USA: 1-800-989-3535 Canada: 1-888-676-7325

website: www.oreck.com

IMPORTANT SAFETY INSTRUCTIONS

When using an electrical appliance, basic precautions should always be followed, including the following:

READ ALL INSTRUCTIONS BEFORE USING THIS STEEMER CLEANER



WARNING

To reduce the risk of fire, electric shock, or injury:

- Do not leave appliance unattended when plugged in. Unplug from outlet when not in use and before servicing.
- Use indoors only.
- Do not immerse motorized nozzle, use only on carpet moistened by cleaning process.
- Do not allow to be used as a toy. Do not allow infants or children around the machine during operation.
- Use only as described in this manual. Use only manufacturer's recommended attachments.
- Do not use with damaged cord or plug. If appliance is not working as it should, has been dropped, damaged, left outdoors, or dropped into water, return it to a service center or call customer service at:
US: 1-800-989-3535 Canada: 1-888-676-7325
- Do not pull or carry by cord, use cord as a handle, close door on cord, or pull cord around sharp edges or corners. Keep cord away from heated surfaces.
- Do not run appliance over cord.
- Do not unplug by pulling on cord. To unplug, grasp the plug, not the cord.
- Do not handle plug or appliance with wet hands.
- Do not put any object into openings. Do not use with any opening blocked; keep free of dust, lint, hair and anything that may reduce air flow.
- Keep hair, loose clothing, fingers and all parts of body away from openings and moving parts.
- Do not use to pick up anything that is burning or smoking, such as cigarettes, matches, or hot ashes.
- Turn off all controls before unplugging.
- Use extra care when cleaning on stairs.
- Do not use to pick up flammable or combustible liquids, such as gasoline or lighter fluid, or use in areas where they may be present.
- Do not use appliance in an enclosed space where flammable, explosive or toxic vapors are given off by oil base paint, paint thinner, some mothproofing substances, or in an area where flammable dust is present.
- Immediately switch off and unplug appliance if water or cleaning solution is observed leaking from machine during operation.
- To prevent overfilling the recovery water tank, empty the recovery water tank every time the clean water tank is filled.
- Always turn off the appliance before connecting or disconnecting motorized nozzle.

SAVE THESE INSTRUCTIONS

Household Use Only

Warranty

ORECK MANUFACTURING COMPANY: (Oreck Manufacturing Company gives you the following limited warranty for this product only if it was originally purchased for residential use, not resale from Oreck or an Oreck Authorized Retail Dealer.)

Oreck will repair or replace, free of charge, to the original purchaser, any part which is found to be defective in material or workmanship within two (2) years of the date of purchase. This limited warranty applies to normal domestic use. Any commercial use of this product will void this limited warranty. Any use of non-Oreck cleaning solutions with this unit will void this limited warranty.

This limited warranty does not cover the replacement of expendable or consumable parts such as belts, brushes, and other parts subject to normal wear unless they are defective in material or workmanship.

This limited warranty does not apply to any part subjected to accident, abuse, commercial use, alteration, misuse, damage caused by act of God, the use of voltages other than indicated on the serial number displayed on this product or service of this product by other than Oreck or a participating Factory Authorized Service Center.

Oreck does not authorize any person or representative to assume or grant any other warranty obligation with the sale of this product.

Oreck's limited warranty is valid only if you retain proof of purchase from Oreck or an Oreck Authorized Retail Dealer for this product. If you purchase this product from any other source, your purchase is "AS IS," which means Oreck grants you no warranty, and that you, not Oreck, assume the entire risk of the quality and performance of this product, including the entire cost of any necessary servicing or repairs of any defects.

Oreck's liability for damages to you for any costs whatsoever arising out of this statement of limited warranty shall be limited to the amount paid for this product at the time of original purchase, and Oreck shall not be liable for any direct, indirect, consequential or incidental damages arising out of the use or inability to use this product.

Some states do not allow the exclusion or limitation of incidental or consequential damages, so the above limitation or exclusion may not apply to you.

ALL EXPRESS AND IMPLIED WARRANTIES FOR THIS PRODUCT, INCLUDING IMPLIED WARRANTIES OF MERCHANTABILITY AND FITNESS FOR A PARTICULAR PURPOSE, ARE LIMITED IN DURATION TO THE WARRANTY PERIOD, AND NO WARRANTIES, WHETHER EXPRESS OR IMPLIED, WILL APPLY AFTER THIS PERIOD.

Some states do not allow limitations on the duration of implied warranties, so the above limitation may not apply to you.

This warranty gives you specific legal rights, and you may also have other rights which vary from state to state.

CALL CUSTOMER SERVICE HOT LINE
US: 1-800-989-3535 Canada: 1-888-676-7325

Whenever calling, please be sure to have your model and serial number from data plate.

Safety Precautions

Several key precautions must be followed to insure operator safety:

1. Always test and reset the Steemer A.L.C.I. plug.
2. Do not immerse the hand-held nozzle of the Oreck Steemer.
3. Do not allow the lower recovery tank to overfill.
4. Do not pick up corrosive, combustible, or flammable liquids such as acids, gasoline, alcohol, or use this product in areas where vapors from these types of materials are present.
5. Do not use to clean out bathtubs, flooded basements or any place where the liquid depth exceeds 1/8".

Troubleshooting Guide



WARNING: Unplug cord from electrical outlet before servicing.

PROBLEM	SOLUTION
Water and cleaning solution is not dispensing onto carpet or upholstery.	<ul style="list-style-type: none"> • Check that the upper supply tank is partially filled with hot tap water. Caution: Do not overfill. • Check that a cleaner cartridge is installed and that the white lever is locked in the downward position. Due to pressurization, the cleaner will not properly operate without a cleaner cartridge in place. If the cleaner cartridge is empty, replace it with a full cartridge. • Check that the spray tips are not clogged. Use a towel or damp cloth to clean. • For above-the-floor cleaning, check that the hand-held nozzle and hose assembly is properly connected to the cleaner neck. Also, insure that the nozzle change button has been engaged.
Not removing certain stains. Heavy traffic area spots.	<ul style="list-style-type: none"> • For best results, use a stain pretreatment, such as Full Release® Professional Spot & Stain PreCleaner. These solutions loosen and break down most common household grease, oil, and food stains. • Make several slow passes over the stain from different angles.
Carpet is excessively wet after cleaning. Note: Under normal conditions, a carpet may take up to four hours or longer to completely dry. Drying time depends on a combination of various factors including: carpet type, carpet pile thickness, temperature, humidity, air circulation and the number of wet passes.	<ul style="list-style-type: none"> • Make at least one additional pass over the wet carpet without pressing the cleaner spray button. • Check that the hand-held nozzle trigger is not engaged. • With each pass, slowly pull the unit toward you to extract any remaining liquid in the carpet. To speed drying, gently push the nozzle deep into the carpet pile. • Check for air path obstructions in the stair/upholstery hose, cleaner neck and in the nozzle. Check to insure that the inlet screen is free of debris.
Excessive foaming at spray tips.	<ul style="list-style-type: none"> • Check that the upper supply tank has water.
Dark streaks on carpet after cleaning.	<ul style="list-style-type: none"> • Operate the machine more slowly; you will achieve better results with one slow pass than several fast strokes. • Overlap each pass to provide maximum cleaning without streaking. • On high traffic areas or heavily soiled carpets, it is occasionally beneficial to allow the carpet to dry and repeat the process as needed to achieve optimal cleaning.
Steamer brush roll will not turn.	<ul style="list-style-type: none"> • Check that the nozzle power cord is completely connected to the main unit. • If an obstruction stalls the brush roll, the belt is designed to burn through so as to protect the motor. Please insure through inspection that the brush roll is free of obstructions and is free to turn. Secondly, make sure that the belt is in good working order. Replace the belt if needed. • If the belt and the brush roll become excessively wet, momentary slippage can occur. By running the unit on a dry section of carpet for a minute or less, the belt will function properly.
Cleaner will not run or suddenly stops.	<ul style="list-style-type: none"> • Reinsert the plug if it has slipped out of the outlet. • The A.L.C.I. may have tripped off due to fluctuations in household current. Press the reset button and restart the unit.

ALL OTHER SERVICING SHOULD BE DONE BY AN ORECK AUTHORIZED SERVICE CENTER.

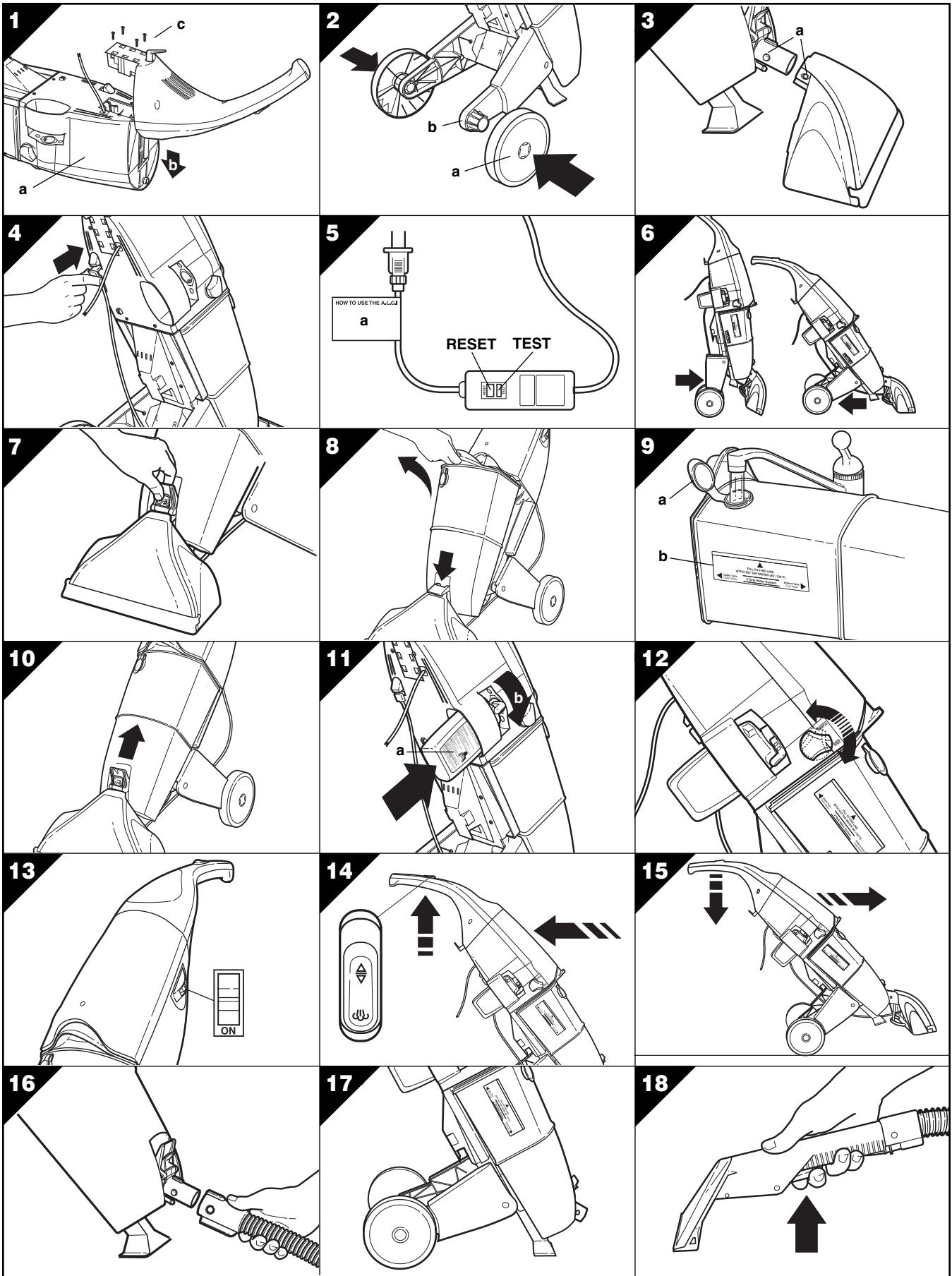

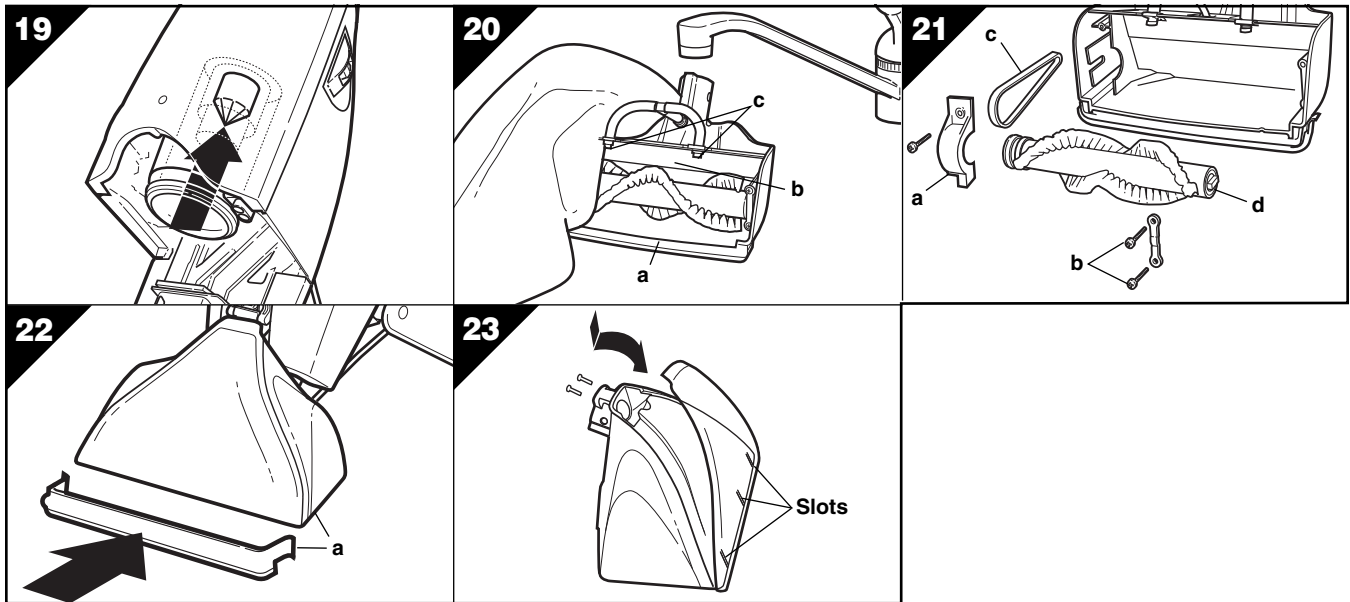

Parts Checklist

Read all instructions thoroughly before assembly/use. Please unpack carton, removing all parts and packages. Check that all parts required for assembly are present by referencing the list below.

PARTS	QUANTITY
1. Oreck Steamer Unit	1
2. Handle	1
3. Oreck Steamer Power Nozzle	1
4. Large, Easy-To-Steer Wheels	2
5. Easy Lock-in Cleaner Cartridge/Bottle	1
6. Screws (5/8")	4
7. Hand-held Nozzle and Hose Assembly	1
8. Squeegee (for hard floor cleaning)	1

Features

9. 25' Power Cord
10. A.L.C.I. – Safety Plug with Reset and Test Buttons
11. Translucent Upper Supply Tank
12. Translucent Lower Recovery Tank
13. Transparent Nozzle Cover
14. Motorized Scrubbing Brush
15. Convenient Quick-Release Cord Wrap
16. Floor Stand
17. Nozzle Power Cord
18. Support Legs

OPERATOR CONTROLS

19. Rinse/Shampoo Switch
20. Shampoo/Cleaner Spray Button
21. A.L.C.I. Plug Reset Button
22. Tank Latch
23. On/Off Power Switch
24. Nozzle Change Button
25. Hand-held Nozzle Trigger

To Assemble Cleaner

A PHILLIPS SCREWDRIVER IS REQUIRED FOR ASSEMBLY!

fig. 1 Attach Handle to Cleaner:

- a. Lay the cleaner on a flat surface with the tank side down or to its side.
- b. Slide handle into cleaner body until interlock is secured.
- c. Insert four 5/8" screws (included) into the four cavities in the handle base and tighten.

fig. 2 Attach Wheels:

- a. Locate two wheels and two support legs.
- b. Insert the wheels (a) into the support legs (b) by pushing the wheels in until they snap into place.

fig. 3 Attach Nozzle:

Turn the unit so that the tank is face up.

- a. Align the nozzle so the nozzle change button is in line with the corresponding hole in the nozzle. Depress the small nozzle change button and slide the nozzle over the unit shaft until the button locks into place.

- fig. 4 Plug the small nozzle cord connected to the nozzle into the receptacle in the back of the unit.

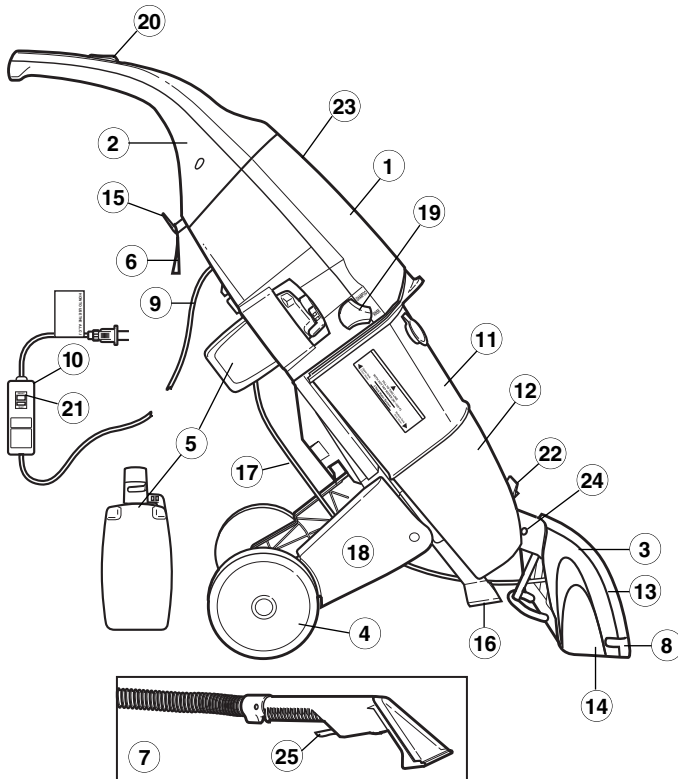

NOTE: Before using, please read the important safety and operating instructions.

Servicing of Double-Insulated Appliances

A double-insulated appliance is marked with one or more of the following: The words "Double Insulation" or "Double Insulated" or the double-insulation symbol (■). In a double-insulated appliance, two systems of insulation are provided instead of grounding. No grounding means it is provided on a double-insulated appliance, nor should a means for grounding be added to the appliance. Servicing a double-insulated appliance requires extreme care and knowledge of the system and should be done only by qualified service personnel. Replacement parts for a double-insulated appliance must be identical to the parts they replace.

Polarization Instructions:

To reduce the risk of electric shock, the Oreck Steemer model is equipped with a polarized alternating current line plug (a plug having one blade wider than the other). This plug will fit into a polarized outlet only one way. This is a safety feature. If you are unable to fit the plug fully into an outlet, try reversing the plug. If the plug should still fail to fit, contact a qualified electrician to replace the obsolete outlet. Do not defeat the purpose of the polarized plug in any way.

A.L.C.I

The Oreck Steemer is made to double-insulated specifications and is equipped with an A.L.C.I. (Appliance Leakage Circuit Interrupter). The A.L.C.I. shuts off the unit in potentially hazardous situations.

fig. 5 The A.L.C.I. has a Test and Reset button which should be tested each time the unit is plugged in.

- a. Do not remove the tag which provides test instructions from around the cord at the A.L.C.I. (A.L.C.I. may vary from illustration).

DANGER: Improper installation of A.L.C.I. can result in electric shock.

Do not modify or bypass the A.L.C.I. Do not replace any electrical component in this product with anything other than an authorized ORECK replacement part. The risk of electric shock can result if used in the vicinity of improperly grounded stationary appliances (stove, refrigerator, washer, etc.).

To Set-Up Cleaner

The Oreck Steemer carpet and hard flooring cleaner is designed for fast and easy set-up.

fig. 6 Swing the wheels away from the nozzle into the operating position.

Remove the supply/recovery tank:

fig. 7 Pinch the tank release latch together and gently lower the latch to the nozzle. **Do Not Force Latch!**

fig. 8 Push the supply/recovery tank downward toward the nozzle and lift out.

fig. 9 ***Fill the supply tank:***

- a. Open the tank cap.
- b. Fill the tank with hot tap water to the fill line, as noted on the side of the tank.

CAUTION: Do not overfill tank. Do not put any type of shampoo/cleaner into the supply tank.

fig. 10 Close tank cap and place the tank back on the cleaner. Lift the latch to slide the tank upward into position until you hear a "click", signaling that the tank is securely locked into place.

Insert Cleaning Cartridge/Bottle:

NOTE: Steemer will not operate without a cleaner cartridge locked into the docking bay. Use only Steemer Full Release® Professional Carpet Cleaner cartridges, which are specifically formulated to be residue-free. Other carpet shampoo will leave residues in the unit that will, over a short period of time, clog the dispensing system and void your warranty.

Remove the cleaner cartridge/bottle cap.

fig. 11 Insert the cleaner cartridge into the docking bay on the side of the cleaner.

- a. The directions on the cleaner cartridge must be facing out.
- b. Lock and seal the cartridge in the cleaner by rotating the white lever on cartridge from top to bottom.

Test and reset the A.L.C.I.:

fig. 5 Plug in the power cord. Press the test button to shut off power. To reset the A.L.C.I., simply push in the reset button on the plug.

To Prepare Carpet

Always vacuum thoroughly with an ORECK Vacuum Cleaner before using the Oreck Steemer. It provides excellent carpet and hard floor cleaning on surfaces that are free of surface debris.

To achieve best results, high traffic areas and carpet stains should be pretreated prior to cleaning using Steemer Full Release® Professional Spot & Stain PreCleaner.

CAUTION: Before cleaning a carpet for the first time, test a small area for color fastness.

Pour a small amount of Steemer Full Release® Professional Carpet Cleaner on a clean white cloth and blot carpet. Examine this cloth for color removal; if color appears on the cloth, the carpeting is not colorfast and should not be cleaned with any wet extraction process.

NOTE: This product is not recommended for use on carpets made from silk, velvet, wool and some cotton blends. Check the manufacturer's cleaning recommendations.

Operating Instructions

To Clean Carpets

fig. 12 Turn the Shampoo/Rinse switch to the "SHAMPOO" position.

fig. 13 Place power switch in the "ON" position.

fig. 14 Press the spray button in the handle and while lifting the handle slightly, slowly pull the cleaner backwards. Pressing the button releases the cleaner and water mixture. As you pull the nozzle over the sprayed floor the nozzle extracts the solution from the floor and stores the dirty water in the recovery tank.

fig. 15 To move forward, slightly tilt the nozzle off the floor and roll the cleaner forward. Repeat process working in small overlapping rows for even cleaning until the entire room has been completed.

WARNING: Do not push forward! Pull the cleaner towards you to clean. This cleaner has been specifically designed to place the nozzle deep into the carpet.

Push down gently on the handle to lift the nozzle out of the carpet to move forward and reposition the cleaner.

IMPORTANT: Adjust the speed of the cleaning stroke to your carpet. Heavily soiled or stained carpets will require slower strokes. Avoid oversaturation.

To shorten the drying time, go back over the floor pulling slowly backwards without depressing the spray button. Repeat this procedure until you do not see water being pulled through the nozzle.

To Rinse Carpet

fig. 12 Turn the Shampoo/Rinse switch to the "RINSE" position.

fig. 13 Place power switch in the "ON" position.

fig. 14 To rinse carpet, press the spray button in the handle. Slowly pull the cleaner backwards over already cleaned area. Pressing the spray button releases clean water. As you pull the nozzle over the sprayed floor, the nozzle extracts any remaining solution from the floor and stores the extracted water in the recovery tank.

fig. 15 To move forward, slightly tilt the nozzle off the floor and roll the cleaner forward. Repeat process working in small overlapping rows for even cleaning until the entire room has been completed.

CAUTION: Do not allow the lower recovery tank to overflow. Damage to the unit can result. Empty the recovery tank when full and whenever clean water is added to the upper supply tank.

fig. 7 To empty the recovery tank, simply release the tank latch by squeezing the latch together.

fig. 8 Lift the tank out and carry it to a sink or drain. Turn the tank upside down and pour the dirty water out.

fig. 9 Refill the supply tank with clean hot tap water. Replace cleaner cartridge as needed.

NOTE: Cleaner will not operate without a cleaner cartridge locked into the docking bay.

For heavily soiled carpets it may be necessary to clean from several directions to insure that the carpet is thoroughly cleaned.

To Clean Hard Flooring (not Hard Wood):

CAUTION: Do not use steamer on hard wood flooring.

fig. 22 Attach squeegee by first inserting one tab on the squeegee end into the slot on nozzle. Then insert the tab located on other end of squeegee into the nozzle slot.

To remove squeegee (after use) gently pull the handles located on each end of the squeegee until it releases.

NOTE: Attach squeegee for hard surface cleaning. For best results remove squeegee when cleaning carpeted surfaces.

fig. 12 Turn the Shampoo/Rinse switch to the “SHAMPOO” position.

fig. 13 Place power switch in the “ON” position.

fig. 14 Press the spray button in the handle and while lifting the handle slightly, slowly pull the cleaner backwards. Pressing the spray button releases the cleaner and water mixture. As you pull the nozzle over the sprayed floor the nozzle extracts the solution from the floor and stores the dirty water in the recovery tank.

fig. 15 To move forward, slightly tilt the nozzle off the floor and roll the cleaner forward. Repeat process working in small overlapping rows for even cleaning until the entire room has been completed.

WARNING: Do not push forward! Pull the cleaner towards you to clean.

Push down gently on the handle to lift the nozzle off of the floor to move forward and reposition the cleaner.

IMPORTANT: Adjust the speed of the cleaning stroke to your floor conditions. Heavily soiled or stained floors will require slower strokes. Avoid oversaturation.

To shorten the drying time, go back over the floor pulling slowly backwards without depressing the button. Repeat this procedure until you do not see water being pulled through the nozzle.

To Rinse Hard Flooring:

fig. 12 Turn the Shampoo/Rinse switch to the “RINSE” position.

fig. 13 Place power switch in the “ON” position.

fig. 14 To rinse hard flooring, press the spray button in the handle. Slowly pull the cleaner backwards over already cleaned area. Pressing the spray button releases clean water. As you pull the nozzle over the sprayed floor the nozzle extracts any remaining solution from the floor and stores the extracted water in the recovery tank.

fig. 15 To move forward, slightly tilt the nozzle off the floor and roll the cleaner forward. Repeat process working in small overlapping rows for even cleaning until the entire room has been completed.

CAUTION: Do not allow the lower recovery tank to overflow. Damage to the unit can result. Empty the recovery tank when full and whenever clean water is added to the upper supply tank.

fig. 7 To empty the recovery tank, simply release the tank latch by squeezing the latch together.

fig. 8 Lift the tank out and carry it to a sink or drain. Turn the tank upside down and pour the dirty water out.

fig. 9 Refill the supply tank with clean hot tap water. Replace cleaner cartridge as needed.

NOTE: Cleaner will not operate without a cleaner cartridge locked into the docking bay.

Sample Cleaning Procedures:

You can use the Oreck Steamer cleaner in many ways to achieve optimal results. The following chart is a guide to usage, however, feel free to use it in a manner which you think is most effective depending on the surface.

The procedure section indicates the types of passes to use on the flooring. For example “Shampoo-Dry-Rinse-Dry” means, one shampoo pass, then one dry pass, one rinse pass (water only), then one dry pass.

Carpet Cleaning	
Situation	Procedure
Monthly Maintenance Cleaning - Quick	Shampoo - Dry
Monthly Maintenance Cleaning - Standard	Pre-treat with “Spot & Stain Remover” as necessary. Shampoo-Dry-Rinse-Dry
Monthly Maintenance Cleaning - Thorough	Pre-treat with “Spot & Stain Remover” Shampoo-Dry-Rinse-Dry Rinse-Dry
<ul style="list-style-type: none"> • Thicker Carpet • Heavy Duty Cleaning • Traffic Lanes • Spots 	Pre-treat with “Spot & Stain Remover” Shampoo-Dry-Rinse-Dry Rinse-Dry
Hard Floor Cleaning	
Situation	Procedure
Quick Clean	Shampoo-Dry
Standard Clean	Pre-treat with “Spot & Stain Remover” as necessary. Shampoo-Dry-Rinse-Dry
Heavy Duty Clean	Pre-treat with “Spot & Stain Remover” Shampoo-Dry-Rinse-Dry Rinse-Dry

NOTE: Additional drying passes can be used to reduce carpet and hard floor moisture and shorten drying time.

For Above the Floor Cleaning - Cars, Stairs, Etc.:

CAUTION: Set the button in the handle to the floor (back) position when using the hand held nozzle for extraction only.

Unplug the cleaner from the electrical outlet.

fig. 4 You will first need to unplug the separate power nozzle cord that connects the Steamer nozzle to the cleaner.

fig. 3 Remove the nozzle by depressing the button located on the side of the neck. Pull the nozzle straight back and off the neck without twisting.

fig. 17 Lower cleaner onto floor stand.

fig. 7/8 Remove the supply/recovery tank from the cleaner.

fig. 9 Open tank cap. Fill with hot tap water, close tank cap.

fig. 10 Replace tank onto cleaner.

fig. 16 Attach the hand-held nozzle and hose assembly to the cleaner neck. Align the guide tab on top of unit’s neck with slot in hose collar. Depress the button and push the hose collar onto the unit until the button locks securely in the collar hole.

fig. 13 Place power switch in the “ON” position.

fig. 14 Press the spray button in the handle and push forward to lock.

fig. 18 Press the cleaner dispensing trigger on the hand-held nozzle to release cleaner.

To Prepare Upholstery:

IMPORTANT: Prior to cleaning any upholstered furniture, read the following instructions very carefully.

Most modern upholstery fabrics may be safely cleaned by wet cleaning methods; yet there are exceptions to this, as some delicate or unusual fabrics require “dry cleaning.” If you are in doubt about the type of fabric, we suggest that you check with the manufacturer or dealer where the furniture was purchased. Most fabrics are wear coded by the manufacturer which details cleaning methods for a particular fabric. If necessary, bring in a cushion or arm cover to your dealer.

- Cleaning upholstery which is covered with fabrics that are not compatible with wet cleaning may result in damage to the fabric. Know what the fabric is and how it may be cleaned before using the Oreck Steamer cleaner.
- Check the stuffing material if possible. Look inside cushions and underneath the furniture. If the filling is colored, it may bleed through and discolor the furniture. Most modern stuffing material is light colored and colorfast.
- To remove loose dirt, vacuum upholstery thoroughly with a vacuum cleaner.
- If the upholstery is being cleaned for the first time, **CHECK FOR COLORFASTNESS**. Test a small area several hours before starting to clean upholstery. Pour a small amount of Steamer Full Release® Professional Upholstery Shampoo on a clean white cloth and blot upholstery. Examine the cloth for color removal. If color appears on cloth, the upholstery is not colorfast and should not be cleaned with wet extraction methods. Let test area dry completely. Inspect for changes in color, bleeding, stretching or shrinkage. Test another area if in doubt. **This product is not recommended for use on silk, velvet, wool and some cotton blends.**

To Clean Upholstery & Small Spill Pick-Ups:

Plug cord into an electrical outlet.

fig. 12 Turn the Shampoo/Rinse switch to the “SHAMPOO” position.

fig. 5 Test and reset A.L.C.I. on the plug.

fig. 11 Insert a specially formulated Steamer Full Release® Professional Upholstery Cleaner Cartridge.

fig. 13 Turn cleaner on by placing the On/Off power switch in the “ON” position.

fig. 14 Lock the cleaner spray button by pressing and sliding the button forward on the main handle.

fig. 18 Depress the dispensing trigger on the hand-held nozzle and slowly drag the nozzle towards you. Make a second pass at right angles to the first. This will minimize any streaking or uneven appearance.

To Clean Carpet Cleaner

WARNING: To reduce the risk of electric shock or injury from moving parts, unplug before servicing.

Before turning the cleaner off, tilt the cleaner back, raising the nozzle off the carpet for 15-20 seconds. This prevents extracted water in the nozzle from dripping back onto the carpet after you turn the cleaner off.

fig. 13 Place the power switch in the “OFF” position. Unplug the power cord from the outlet.

fig. 11 Remove the cleaner cartridge by rotating the locking lever upwards. **Do not store with a cleaner cartridge installed.**

fig. 8 Remove and empty the tank. Rinse out the lower recovery tank with warm water.

fig. 19 Wipe off the inlet screen to remove accumulated dirt, lint and debris.

fig. 10 Replace tank.

fig. 20 If you have been operating the cleaner at length, it may be necessary to clean the nozzle from time to time, particularly if the carpet is brand new or very dirty, or if long-haired pets frequently use the carpeted area. Unplug cleaner and examine several areas on the power nozzle to see if debris has built up:

- Extractor slots
- Brush roll chamber
- Spray Tips

fig. 20 To clean the Steamer extractor slots, place a cloth or towel over the motor cover to shield and protect the motor from water damage. Run hot tap water through the nozzle until clean.

To clean the brush chamber and spray tips, take a towel or damp cloth and wipe clean.

To Store Cleaner

fig. 6 Pull the wheel assembly forward toward nozzle for compact storage.

NOTE: Do not store the cleaner in freezing conditions. Do not store the cleaner with water in the tank. Do not store the cleaner with cleaner cartridge installed. Turn the squeegee upside down for storage. Squeegee will deform if left in position while in storage.

Things To Do

- Use only manufacturer’s recommended attachments and accessories.
- Keep free of dust, lint, and hair.
- Turn off all controls before unplugging.
- Test the A.L.C.I. plug with every use.
- Empty the recovery tank when full and whenever clean water is added to the supply tank.
- Keep young children and pets away from cleaned carpets until dry.
- Check carpets and upholstery for color fastness.
- Clean nozzle periodically.

To Replace Belt

WARNING: To reduce the risk of electric shock or injury from moving parts, unplug before servicing.

Replacement belts (53364-01) for Oreck Steamers are available from Oreck. Call Toll-Free 1-800-989-3535 (US) or 1-888-676-7325 (Canada).

fig. 4 Unplug the power nozzle cord leading from the power head to the rear of the main cleaner.

fig. 3 Remove the power nozzle from the main cleaner.

fig. 21 *Disassemble Power Nozzle:*

- Remove screw from belt cover.
- Remove two (2) screws holding the brush roll clamp in place and remove clamp.
- Remove and replace the old belt if broken or if excessive wear is noted.

To Install a New Belt:

fig. 21 Remove brush roll and insert the new belt into the rectangular cavity. Using a long screwdriver, loop belt around motor shaft. Pull and stretch belt over crowned end of the brush roll. Rotate brush to properly align belt.

fig. 21 Replace belt cover, brush roll clamp and screws.

fig. 3 Reattach power nozzle to unit.

fig. 4 Reconnect power nozzle cord and power cord.

fig. 5 Test and reset A.L.C.I. on the plug.

To Clean Power Nozzle Cover

fig. 23 Remove two screws from top of cover

- Tilt cover forward and pull down to unhook tabs from slots in Power Nozzle Housing.
- Clean cover and housing to remove debris.
- Hook cover tabs into slots on Power Nozzle Housing.
- Pivot cover backward and fasten with two screws.