



**Wireless Acrylic Weather Station &
Atomic Alarm Clock
Model : BAR618HGA**

User Manual



N

CONTENTS

Contents	1
Introduction	2
About Oregon Scientific	2
Product Overview	3
Front View	3
Back View	4
Remote Sensor (THGR122NX)	5
Getting Started	6
Batteries	6
Change Settings	6
Table Stand or Wall Mount	6
Remote Sensor (THGR122NX)	6
Setup Sensor	6
Data Transmission	8
Search for Sensor	8
Clock	8
Turn Atomic Clock ON/OFF	9
Set Clock	9
Switch Clock Display	9
Alarms	9
View Alarm Settings	9
Set Alarm	9
Activate Alarm	9
Silence Alarm	9
Barometer	10
Barometric Trend	10
Weather Forecast	10
Temperature and Humidity	10
Select Temperature Unit	10
Select Channel Number	11
Minimum / Maximum Records	11
Moon Phase	11
Backlight	11
Reset System	11
Safety and Care	11
Warnings	12
Troubleshooting	12
Specifications	13
Main Unit Dimensions	13
Remote Sensor Dimensions	13
Temperature	13
Relative Humidity	13
Barometer and Weather Forecast	13
Remote Sensor (THGR122NX)	13
Clock	13
Power	14
FCC Statement	14



EN

INTRODUCTION

Thank you for selecting the Oregon Scientific™ **Wireless Acrylic Weather Station & Atomic Alarm Clock** (BAR618HGA). This device bundles precise time keeping, weather forecast, barometric trend, and indoor and outdoor temperature and humidity monitoring features into a single tool you can use from the convenience of your home.

In this box, you will find:

- Main unit
- Remote sensor (THGR122NX)

Keep this manual handy as you use your new product. It contains practical step-by-step instructions, as well as technical specifications and warnings you should know.

ABOUT OREGON SCIENTIFIC

Visit our website (www.oregonscientific.com) to learn more about other Oregon Scientific products such as digital cameras, hand-held organizers, health and fitness gear, and projection clocks. The website also includes contact information for our customer service department, in case you need to reach us.



25

PRODUCT OVERVIEW

FRONT VIEW

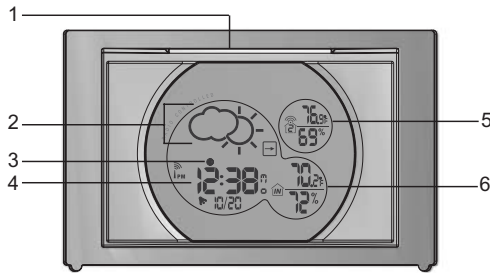

1. **SNOOZE / LIGHT** button
2. Weather Forecast & Barometric Trend Area
3. Moon Phase
4. Clock / Calendar / Alarm Area
5. Outdoor Temperature & Humidity Area
6. Indoor Temperature & Humidity Area

3

EN

BACK VIEW

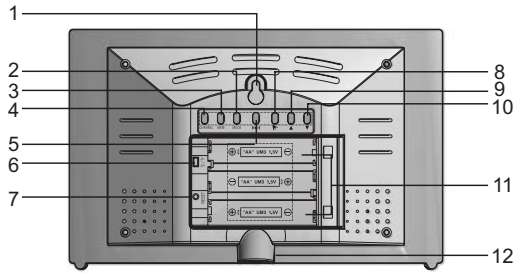

- 1. Wall mount
- 2. **MODE**: change display / settings
- 3. **MEMORY**: view current, maximum and minimum temperature / humidity readings
- 4. **CHANNEL**: switch remote sensor
- 5. **((.))**: view alarm status; set alarm
- 6. °C / °F switch
- 7. **RESET** hole
- 8. : turn alarm off for 24 hours
- 9.10. and : increase or decrease setting / activate or deactivate Atomic Clock.
- 11. Battery compartment
- 12. Table stand



25

REMOTE SENSOR (THGR122NX)

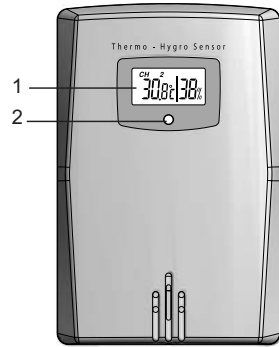

- 1
- 2

- 1. LCD display
- 2. LED Status indicator

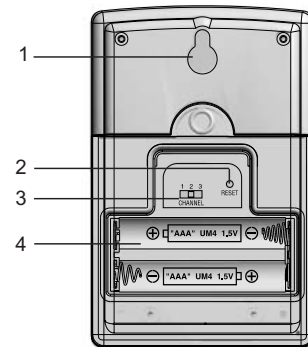

- 1
- 2
- 3
- 4

- 1. Wall mount hole
- 2. **RESET**
- 3. Channel number (1 - 3)
- 4. Battery compartment
(Battery compartment cover not shown)

N

GETTING STARTED

BATTERIES

Batteries are not supplied with this product. You will need to purchase 3 x UM-3 (AA) 1.5V alkaline batteries for the main unit, and 2 x UM-4 (AAA) 1.5V alkaline batteries for the remote sensor.

Insert batteries before first use, matching the polarity as shown in the battery compartment. For best results, install batteries in the remote sensor before the main unit. Press **RESET** after each battery change.

NOTE Do not use rechargeable batteries.

 shows when batteries are low.

UNIT	 LOCATION
Main	Indoor Temperature / Humidity Area
Remote	Outdoor Temperature / Humidity Area

CHANGE SETTINGS

1. Press and hold **MODE** for 2 seconds to enter setting mode.
2. Press **UP** or **DOWN** to change settings.
3. Press **MODE** to confirm.

TABLE STAND OR WALL MOUNT

Use the stand on the back of the product, or mount it on a wall with a nail.

REMOTE SENSOR (THGR122NX)

This product is shipped with a THGR122NX Thermo/Hygro Sensor that collects Temperature and Humidity data. Data can be collected from up to 3 sensors. Additional sensors sold separately.

SETUP SENSOR

1. Open the remote sensor battery compartment with a small Phillips screwdriver.
2. Insert the batteries, matching the polarity as shown in the battery compartment.
3. Set the channel. The switch is located in the battery compartment.

SWITCH	OPTION
Channel	Channel 1 - 3. If you are using more than one sensor, select a different channel for each sensor.



N
W

4. Place the sensor near the main unit. Press **RESET** on the sensor. Then, press and hold **MEM** and **CHANNEL** on the main unit to initiate signal sending between the sensor and the main unit. The reception icon on the main unit will blink for approximately 3 minutes while it is searching for the sensor. (Refer to the Sensor Data Transmission section for more information.)
5. Close the remote sensor battery compartment.
6. Secure the sensor in the desired location using the wall mount or table stand.

For best results:

- Insert the batteries and select the channel before you mount the sensor.
- Place the sensor out of direct sunlight and moisture.
- Do not place the sensor more than 30 meters (98 feet) from the main (indoor) unit.
- Position the sensor so that it faces the main (indoor) unit, minimizing obstructions such as doors, walls, and furniture.
- Place the sensor in a location with a clear view to the sky, away from metallic or electronic objects.
- Position the sensor close to the main unit during cold winter months as below-freezing temperatures may affect battery performance and signal transmission.

You may need to experiment with various locations to get the best results.



DATA TRANSMISSION

Data is sent from the sensor(s) every 40 seconds. The reception icon shown in the Temperature and Humidity Areas show the status.

ICON	DESCRIPTION
	Main unit is searching for sensors.
	At least 1 channel has been found.
	Channel 1 is selected (number will change depending on the sensor you select)
--- shows in Outdoor Temp / Humidity Area	The selected sensor cannot be found. Search for the sensor or check batteries.

SEARCH FOR SENSOR

To search for a sensor, press and hold **MEM** and **CHANNEL** for 2 seconds.

NOTE If the sensor is still not found, check the batteries, obstructions, and remote unit location.

NOTE Signals from household devices such as doorbells, electronic garage doors, and home security systems may cause temporary reception failure. This is normal and does not affect general product performance. The reception will resume once the interference ends.



CLOCK

This product shows the current time, and day of week in English, French, German, Italian, or Spanish. The US Atomic Clock in Boulder, Colorado automatically updates this information unless you disable the feature. The signals are collected by the main unit when it is within 1500 km (932 miles) of a signal.

Initial reception takes 2 - 10 minutes, and is initiated when you first setup the unit, and whenever you press **RESET**. Once complete, the reception icon will stop blinking. The icon is shown in the Clock Area.

Strong signal	Weak signal	No signal

To force a manual search for Atomic Clock signals, press and hold **UP** for 2 seconds. If no signal is found, check the batteries.

NOTE If the Atomic Clock signal is received and the hour is incorrect, use the "timezone offset" feature to adjust it to the appropriate timezone. Please see "SET CLOCK" on pg. 9 for instructions.



Z
W

TURN ATOMIC CLOCK ON/OFF

Perform this step if you cannot receive Atomic Clock signals. Press and hold **DOWN** for 2 seconds. Then, manually set the clock following the "Set Clock" instructions (below).



The signal icon indicates that the Atomic Clock feature is ON. No icon means that it is OFF.

SET CLOCK

You only need to do this if you have disabled the Atomic Clock feature (for example, if you are too far from or cannot receive a signal).

1. Press and hold **MODE** for 2 seconds. The Clock Area will blink.
2. Select the time zone, hour, minute, year, month, day, and language. Press **UP** or **DOWN** to change the setting. Press **MODE** to confirm.

NOTE The time zone options are (PA) Pacific, (CE) Central, (MO) Mountain, and (EA) Eastern.

NOTE The language options are (E) English, (F) French, (D) German, (I) Italian, and (S) Spanish.

SWITCH CLOCK DISPLAY

Press **MODE** to toggle between Clock with Seconds and Clock with Weekday display.

ALARMS

This product is equipped with a 2-minute crescendo alarm.



VIEW ALARM SETTINGS

Press **((.))**. The Alarm Time and **((.))** status will show in the Clock Area.

SET ALARM

1. Press **((.))** to switch to Alarm display.
2. Press and hold **((.))** again for 2 seconds. The Alarm settings will blink.
3. Select the hour and minute. Press **UP** or **DOWN** to change settings. Press **((.))** to confirm.

ACTIVATE ALARM

Press  to activate or deactivate the Alarm.  shows in the Clock / Alarm Area when the Alarm is activated.

SILENCE ALARM

When the Alarm time is reached, the crescendo alarm will sound for 2 minutes. Press **SNOOZE / LIGHT** to silence it for 8 minutes.  Or, press to turn it off until the next day.





EN

If no button is pressed, the Alarm will automatically silence after 2 minutes. It will then sound again after 8 minutes.

BAROMETER





This product tracks barometric pressure changes over the past 24 hours to provide the weather forecast and a trend line showing the direction of barometric change. Barometric changes are measured by the main (indoor) unit.

BAROMETRIC TREND

Trend	Description
	Rising
	Steady
	Falling

WEATHER FORECAST

This product forecasts the next 12 to 24 hours of weather within a 30 to 50 km (19 - 31 mile) radius with 70 to 75 percent accuracy. The weather forecast is always displayed.

Clear	Partly Cloudy	Cloudy	Rainy
			

TEMPERATURE AND HUMIDITY

This product can display current, minimum, and maximum temperatures and humidity percentage information collected by the remote sensors and main (indoor) unit.

Outdoor data is displayed every 40 seconds. Indoor data is collected and displayed every 10 seconds.

SELECT TEMPERATURE UNIT

Slide the °C / °F switch into the desired location. The switch is located inside battery compartment of the product. The setting for the main unit overrides the remote sensor setting.



N
W

SELECT CHANNEL NUMBER

Press **CHANNEL** to switch between sensors 1 - 3.

The icon shows the selected sensor.

Kinetic-wave Icon			
Designated Display	Remote Display Channel 1	Remote Display Channel 2	Remote Display Channel 3

To auto-scan between sensors, press and hold **CHANNEL** for 2 seconds. Each sensor's data will be displayed for 3 seconds. To end auto-scan, press **CHANNEL** or **MEM**.

NOTE If you use a sensor that collects only temperature data, humidity will not be shown.

MINIMUM / MAXIMUM RECORDS

Press **MEM** to toggle between current, maximum (MAX) and minimum (MIN) records. To clear the records, press and hold **MEM** for 2 seconds. A beep will sound to confirm that the memory has been cleared.

MOON PHASE

The Calendar must be set for this feature to work. (→ 9). Press **▲** or **▼** to view the moon phase for the next or previous day. Press and hold **▲** or **▼** to scan quickly through the years (2001 to 2099).

BACKLIGHT

Press **SNOOZE / LIGHT** to activate the backlight for 8 seconds.

RESET SYSTEM

The **RESET** buttons are located in the battery compartments for the main unit and sensors. Press **RESET** when you change the batteries and whenever performance is not behaving as expected (for example, unable to establish radio frequency link with remote sensor or Atomic clock).

NOTE When you press **RESET**, all settings will return to default value, and you will lose all stored information.

SAFETY AND CARE

Clean the product with a slightly damp cloth and alcohol-free, mild detergent. Avoid dropping the product or placing it in a high-traffic location.



WARNINGS

This product is designed to give you years of service if handled properly. Observe the following guidelines:

- Never immerse the product in water. This can cause electrical shock and damage the product.
- Do not subject the main unit to extreme force, shock, or fluctuations in temperature or humidity.
- Do not tamper with the internal components.
- Do not mix new and old batteries or batteries of different types.
- Do not use rechargeable batteries with this product.
- Remove the batteries if storing this product for a long period of time.
- Do not scratch the LCD display.

Do not make any changes or modifications to this product. Unauthorized changes may void your right to use the product. The technical specification of this product and contents of this user guide are subject to change without notice. Images not drawn to scale.

TROUBLESHOOTING

Check here before contacting our customer service department.

Problem	Symptom	Remedy
Calendar	Strange date / month	Change language (→ 9)
Clock	Cannot adjust clock	Disable Atomic Clock (→ 9)
	Cannot auto-synch	1. Adjust batteries. (→ 6) 2. Press RESET (→ 11) 3. Manually activate Atomic Clock feature (→ 9)
Temp	Shows "LLL" or "HHH"	Temperature is out-of-range
Remote sensor	Cannot locate remote sensor	Check batteries (→ 6) Check location (→ 7)
	Cannot change channel	Check sensors. Only one sensor is working (→ 6)
	Data does not match main unit	Initiate a manual sensor search (→ 6)



21

SPECIFICATIONS

MAIN UNIT DIMENSIONS

L x W x H	185mm x 120mm x 49.5mm
Weight	305g with battery

REMOTE SENSOR DIMENSIONS

L x W x H	92 x 60 x 20 mm (3.6 x 2.4 x .79 inches)
Weight	63 grams without battery

TEMPERATURE

Unit	°C or °F
Indoor Range	-5 °C to 50 °C (23 °F to 122 °F)
Outdoor Range	-20 °C to 60 °C (-4 °F to 140 °F)
Resolution	0.1 °C (0.2° F)

RELATIVE HUMIDITY

Range	25% to 95%
Resolution	1%
Memory	Minimum / maximum

BAROMETER AND WEATHER FORECAST

Range	700 to 1050 mb (20.67 to 31.01 inHg)
Resolution	1 mb (0.03 inHg)
Display	Rainy, cloudy, partly cloudy, sunny

REMOTE SENSOR (THGR122NX)

RF frequency	433 MHz
Range	30 meters (98 feet) with no obstructions
Transmission	every 40 seconds
Channel No.	1 - 3

CLOCK

Atomic Clock	Auto or manual (disabled)
Clock display	HH:MM:SS
Hour format	12hr AM/PM
Time zone	PA (Pacific), MO (Mountain), CE (Central) or EA (Eastern)
Calendar	MM/DD; weekday in 5 languages (E, D, F, I, S)
Alarm	Single alarm with 2- minute crescendo and 8-minute Snooze



N

POWER

Main unit batteries	3 x UM-3 (AA) 1.5V alkaline
Sensor batteries	2 x UM-4 (AAA) 1.5V alkaline

FCC STATEMENT

This device complies with Part 15 of the FCC Rules. Operation is subject to the following two conditions: (1) This device may not cause harmful interference, and (2) This device must accept any interference received, including interference that may cause undesired operation.

Warning: Changes or modifications to this unit not expressly approved by the party responsible for compliance could void the user's authority to operate the equipment.

NOTE: This equipment has been tested and found to comply with the limits for a Class B digital device, pursuant to Part 15 of the FCC Rules. These limits are designed to provide reasonable protection against harmful interference in a residential installation. This equipment generates, uses and can radiate radio frequency energy and, if not installed and used in accordance with the instructions, may cause harmful interference to radio communications.

However, there is no guarantee that interference will not occur in a particular installation. If this equipment does cause harmful interference to radio or television reception, which can be determined by turning the equipment off and on, the user is encouraged to try to correct the interference by one or more of the following measures:

- Reorient or relocate the receiving antenna.
- Increase the separation between the equipment and receiver.
- Connect the equipment into an outlet on a circuit different from that to which the receiver is connected.
- Consult the dealer or an experienced radio/TV technician for help.



N
W

DECLARATION OF CONFORMITY

The information below is not to be used as contact for support or sales. Please call our customer service number (listed on our website at www.oregonscientific.com, or on the warranty card for this product) for all inquiries instead.

We

Name: Oregon Scientific, Inc.
Address: 19861 SW 95th Place,
Tualatin, Oregon 97062 USA
Telephone No.: 1-800-853-8883
Fax No.: 1-503-684-8883

declare that the product

Product No.: BAR618HGA
Product Name: Wireless Weather Station
Manufacturer: IDT Technology Limited
Address: Block C, 9/F, Kaiser Estate,
Phase 1, 41 Man Yue St.,
Hung Hom, Kowloon,
Hong Kong

is in conformity with Part 15 of the FCC Rules. Operation is subject to the following two conditions:

- 1) This device may not cause harmful interference.
- 2) This device must accept any interference received, including interference that may cause undesired operation.

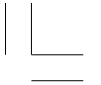

© 2004 Oregon Scientific. All rights reserved.

P/N.: 086-003334-030



BAR618HGA lab test back coverR4

1



2/18/04, 11:27 AM

