

INSTRUCTION MANUAL

Orion EQ-1M & EQ-2M

Single-Axis DC Motor Drive Systems

#7826, #7827



 **ORION**
TELESCOPES & BINOCULARS
Providing Exceptional Consumer Optical Products Since 1975

Customer Support (800) 676-1343

E-mail: support@telescope.com

Corporate Offices (831) 763-7000

89 Hangar Way, Watsonville, CA 95076

Welcome to a new world of adventure. The Orion EQ-1M and EQ-2M Single-Axis DC Motor Drive Systems allow convenient hands-free tracking of the night sky for Orion EQ-1 and EQ-2 equatorial mounts. The motor drive systems are also necessary components for doing any long-exposure astrophotography with the mounts; they provide accurate sidereal tracking with an electronic hand controller for making positional corrections to the right ascension axis of the mount when guiding an astrophoto.

Table of Contents

1. Parts List.....	2
2. Installing the EQ-1M Motor Drive System	2
3. Installing the EQ-2M Motor Drive System	3
4. Operation	3
5. Specifications.....	4

1. PARTS LIST

EQ-1M and EQ-2M

- 1 Motor drive assembly
- 1 Hand controller
- 1 Battery pack

EQ-1M only

- 1 2mm Allen wrench
- 1 4mm Allen wrench

2. Installing the EQ-1M Motor

The EQ-1M Motor Drive System is intended for use with telescopes that utilize the Orion EQ-1 equatorial mount.

- When facing the front of the mount, the right ascension (R.A.) slow-motion control cable should be mounted on the left end of the R.A. worm gear shaft (see Figure 1). If it is mounted on the right end, remove it from the mount, and reinstall it on the left end of the shaft.

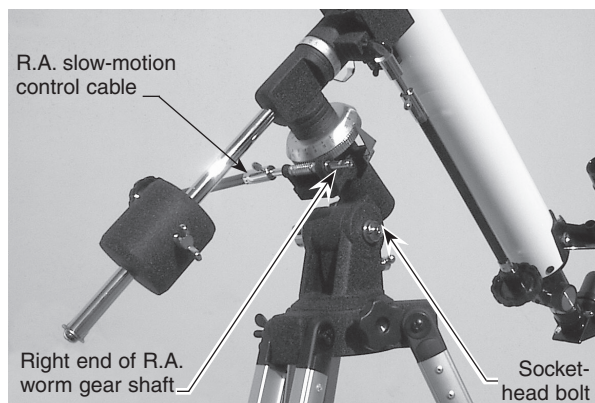

Figure 1. Orion EQ-1M mount with R.A. slow-motion control mounted on left end of R.A. worm gear shaft.

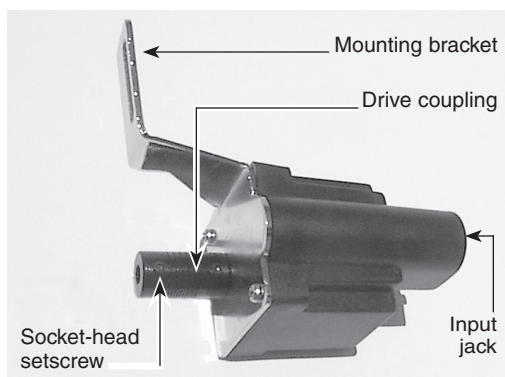

Figure 2. The EQ-1M motor. The socket-head setscrew on the end of the drive coupling connects the motor to the right end of the R.A. worm gear.

- Loosen the socket-head setscrew on the drive coupling of the motor drive assembly (see Figure 2) using the provided 2mm Allen wrench.
- Use the provided 4mm Allen wrench and remove the socket-head bolt on the right side of the equatorial mount (see Figure 1).
- Orient the motor drive so that the drive coupling slips over the right end of the R.A. worm gear shaft. Now, attach the motor to the mount by inserting the socket-head bolt through the slot in the motor drive's bracket, and rethreading it into the mount.
- Tighten the socket head setscrew on the end of the coupling. The setscrew should seat into the groove on the end of the worm gear shaft. You may need to rotate the worm gear, using the R.A. slow-motion control cable, for the setscrew and the groove to line up. Once the setscrew is tightened, the motor is engaged. When the motor is engaged, never, under any circumstances, should you use the R.A. slow-motion control cable! If you want to use the R.A. slow-motion control cable, you must first loosen the socket-head set screw on the end of the drive coupling.

The motor is now properly installed on the EQ-1 mount, and should appear as in Figure 3.

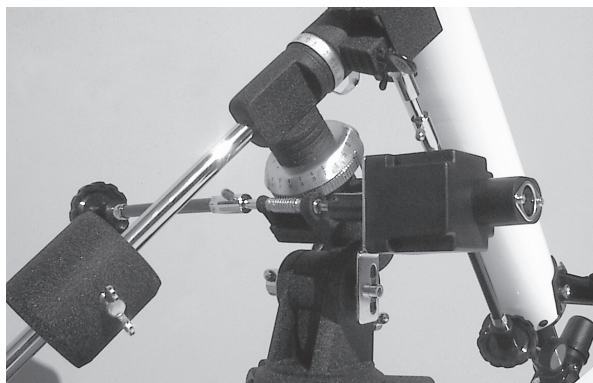

Figure 3. The EQ-1M motor properly installed on the EQ-1 mount.

3. Installing the EQ-2M Motor

The EQ-2M Motor Drive System is intended for use with telescopes that utilize the Orion EQ-2 equatorial mount.

1. Many of the parts used for the EQ-2M Motor Drive System are preinstalled on your EQ-2 mount. The circular gear on the right end of the R.A. worm gear shaft, the odd-shaped clutch mechanism, the motor mounting shaft, and the knurled setscrew just underneath the R.A. worm gear are

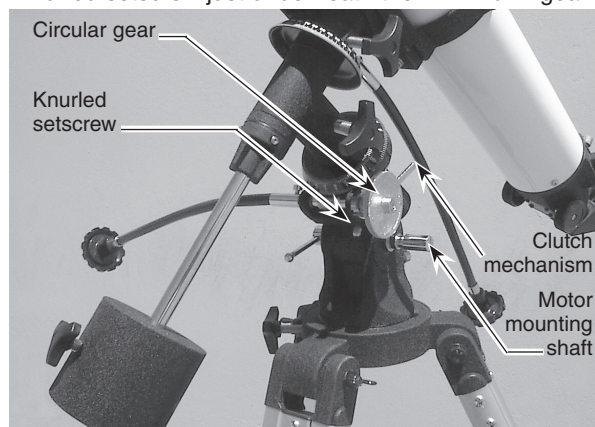

Figure 4. Orion EQ-2 mount comes with many parts of the EQ-2M Motor Drive System preinstalled.

2. The motor itself fits onto the motor mounting shaft. Loosen the motor's locking T-bolt and slide the cylinder of the motor housing onto the shaft. Make sure that the small gear on the motor is just underneath the circular gear on the end of the R.A. worm gear shaft (see Figure 5).
3. Rotate the motor until the motor gear and the circular gear mesh. Tighten the locking T-bolt; the end of the T-bolt should seat into the groove in the motor mounting shaft.
4. Connect the spring (Figure 6) on the motor housing to the knurled setscrew underneath the R.A. worm gear on the equatorial mount. Do this by first loosening the setscrew about five turns. Now, stretch the spring and slide its end ring over the knurled head of the set screw and onto the threads. If you are having trouble stretching the spring with

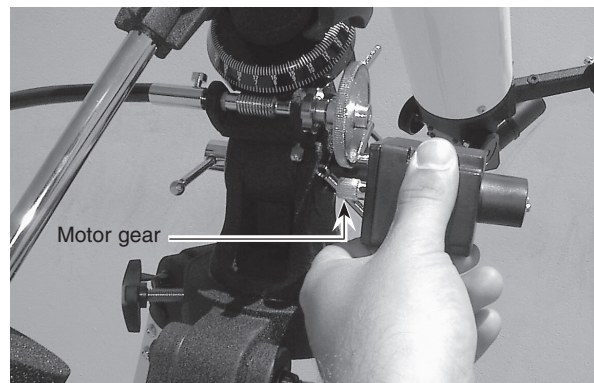

Figure 5. Attaching the EQ-2M motor to the EQ-2 mount. Make sure the motor gear is positioned directly underneath the circular gear.

5. Slightly loosen the locking T-bolt and the motor will engage. When the motor is engaged, never, under any circumstances, should you use the R.A. slow-motion control cable! Disengage the motor to use the R.A. slow-motion cable by rotating the clutch mechanism on the mount clockwise. The clutch mechanism pushes the motor down, and separates the motor gear from the circular gear. Re-engage the motor by rotating the clutch mechanism counter-clockwise; the spring will then pull the motor back up, which causes the motor gear and the circular gear to mesh properly once again. If the spring does not pull the motor up so that the gears mesh, the locking T-bolt is probably too tight.

The motor is now properly installed on the EQ-2 mount, and should appear as in Figure 6.

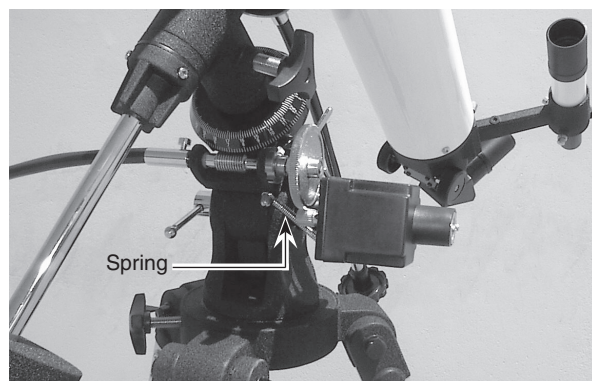

Figure 6. The EQ-2M motor properly installed on the EQ-2 mount.

4. Operation

Insert four D-cell batteries into the battery pack. Orient the batteries as indicated on the white plastic battery holder. Connect the end of the battery pack's power cord to the DC power input on the hand controller. Connect the hand controller plug into the input jack (Figure 2) on the motor.

For the motor drive system to work properly, the equatorial mount must be polar-aligned. This involves aligning the R.A. axis of the mount so it is parallel to the Earth's axis of rotation

(polar axis). Consult the manual that came with your equatorial mount for details on how to polar-align it.

For observers in the Northern Hemisphere, the N/S switch on the hand controller should be in the "N" position, and should be in the "S" position for Southern Hemisphere observers. Make sure the motor is engaged, and turn the power switch on the hand controller to the "ON" position. The LED in the center of the hand controller should be shining green. Tighten the mount's R.A. lock knob. If properly polar-aligned, the mount will now be tracking the motion of the night sky, and the telescope should hold any astronomical object in its eyepiece steady over time.

To move your telescope to a new object, loosen both the R.A. and Dec. lock knobs and move the telescope until it is pointed in the general direction of the object you wish to view. Retighten the R.A. and Dec. lock knobs. Now, disengage the motor and use the R.A. and Dec. slow-motion control cables to center the object in the eyepiece's field-of-view. Re-engage the motor, and the motor drive system will keep the object centered over time. Remember, never use the R.A. slow-motion control cable when the motor is engaged, or you could permanently damage the motor.

There are four buttons on the hand controller. If no buttons are pressed, the motor will turn the R.A. axis of the mount at sidereal rate. If the bottom right button is pressed, the motor will turn at 2x sidereal rate, which will cause objects viewed in the telescope's eyepiece to move slowly eastward. If the bottom left button is pressed, the motor will stop turning (pause), which will cause objects in the eyepiece to move slowly westward. The bottom two buttons are most useful for guiding purposes during long-exposure astrophotography.

Similarly, the top right button on the hand controller moves objects in the telescope's eyepiece quickly eastward, while the top left button moves objects quickly westward.

For the EQ-1M, the top buttons move the mount at 8x sidereal rate, while the EQ-2M's top buttons move the mount at 4x sidereal rate. The top two buttons are most useful for centering an object within the field of view of an eyepiece.

Note that whenever any of the four buttons on the hand controller are pressed, the LED in the center of the hand controller will shine red; when the button is released, the LED will shine green again.

5. Specifications

EQ-1M

Guiding rate: 100% sidereal

Centering rate: 800% sidereal

Power requirement: 6V DC

Battery type: four D-cell

Northern or Southern Hemisphere operation

Externally clutched

EQ-2M

Guiding rate: 100% sidereal

Centering rate: 400% sidereal

Power requirement: 6V DC

Battery type: four D-cell

Northern or Southern Hemisphere operation

Externally clutched

One-Year Limited Warranty

This Orion EQ-1M & EQ-2M Motor Drives are warranted against defects in materials or workmanship for a period of one year from the date of purchase. This warranty is for the benefit of the original retail purchaser only. During this warranty period Orion Telescopes & Binoculars will repair or replace, at Orion's option, any warranted instrument that proves to be defective, provided it is returned postage paid to: Orion Warranty Repair, 89 Hangar Way, Watsonville, CA 95076. If the product is not registered, proof of purchase (such as a copy of the original invoice) is required.

This warranty does not apply if, in Orion's judgment, the instrument has been abused, mishandled, or modified, nor does it apply to normal wear and tear. This warranty gives you specific legal rights, and you may also have other rights, which vary from state to state. For further warranty service information, contact: Customer Service Department, Orion Telescopes & Binoculars, 89 Hangar Way, Watsonville, CA 95076; (800) 676-1343.

Orion Telescopes & Binoculars

89 Hangar Way, Watsonville, CA 95076

Customer Support Help Line (800) 676-1343 • Day or Evening