

**XTREME SERIES
POWER AMPLIFIER
INSTALLATION MANUAL**

 **ORION**
HIGH PERFORMANCE CAR AUDIO

TABLE OF CONTENTS

INTRODUCTION

DESCRIPTION & FEATURES

2-3

SYSTEM PLANNING

4-10

SETTING SIGNAL JUMPERS

11-16

INSTALLATION

17-25

SYSTEM ADJUSTMENTS

26

TROUBLESHOOTING

27

SPECIFICATIONS

28

WARRANTY INFORMATION

29



DESIGN

All ORION amplifiers are designed on our sophisticated CAD system, utilizing the latest technology available.

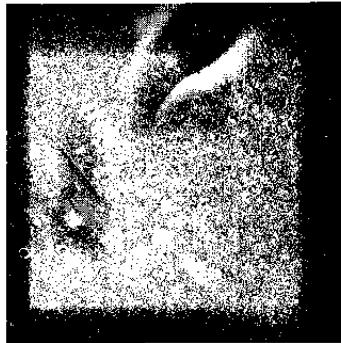

PRODUCTION

All ORION amplifiers are made in the USA, with high-quality, double-sided PC boards containing superior-grade components.

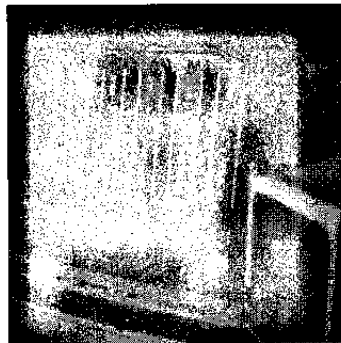

PRODUCT USE

The ORION XTR Series sets new standards for performance and reliability. They can attain sound pressure levels well in excess of 130 dB. Use common sense, and wear hearing protection when appropriate.

INTRODUCTION

Congratulations! You have purchased the finest Car Audio Amplifier available in the market today. The new XTR series of Amplifiers are the result of many years of research and development and ORION's expertise in building high quality, high performance amplifiers. Each ORION amplifier is hand built and thoroughly tested to ensure that it will perform under the most demanding conditions. Our five step quality control process and a two hour "burn-in" help us produce the best sounding, most reliable amps on the planet.

These new amplifiers offer the improved sound quality and raw power you expect from ORION, but as an added bonus we have added two Module Slots. The slots can accept our new (crossovers, and other signal processors that will be introduced in the future.) These new amplifiers are compatible with any speaker system and can be used with existing amplifiers to upgrade your system. This means you don't have to purchase external crossovers.

In the "System Planning Diagram" section we have outlined some killer systems that have been built and tested by our Technical Support Team. Each system has diagrams and pictures of the configuration jumpers to make setting up the inputs and crossovers easy. If you have any question about your new amplifier or need help designing your system call our Technical Support Department at 1-602-730-8200.

DESCRIPTION AND FEATURES

PRS MOSFET POWER SUPPLY (PULSE REGULATED SUPPLY)

A very large regulated power supply improves sound quality and amplifier damping, so that large bass transients are reproduced accurately. ORIONS power supplies are very stable and perform under the most demanding conditions.

TWO BUILT IN MODULE SLOTS

Two internal module slots are wired in series for unlimited system flexibility. Use one crossover module for a 12dB per octave slope or add an additional module to create a bandpass or 24dB per octave crossover. Other types of modules for signal processing will be introduced in the future.

INPUT SIGNAL ROUTING AND SUMMING

The input signal can be routed back out the amplifier via the DIN plug or RCA jacks. The signal can be routed through the internal crossover or be a full range output. The input signal can also be summed mono.

GAIN STAGE BYPASS

The internal gain stage of the amplifier can be bypassed so that one master amplifier can be used to control the gain of the slave amplifiers. This can be used in systems with multiple low frequency amps to perfectly level match the system. In addition, the gain stage on the high frequency amplifier can be bypassed for improved sound quality and a better signal to noise ratio. The signal to noise ratio is improved by as much as 10dB.

REMOVABLE TOP PANEL

This provides easy access to the crossover ports and signal jumpers. After the amplifier is installed it is very easy to add a crossover module or reconfigure the input jumpers. To remove panel use a small flat blade screwdriver. Use screwdriver on endplate in the hole marked "cover release".

LARGE QUICK DISCONNECT POWER, GROUND AND SPEAKER CONNECTORS

These new connectors accept larger gauge wire and simplify the installation. With less power loss, the overall power and performance of the system is improved.

LARGE EFFICIENT HIGH EFFICIENCY HEAT SINK

Large CNC machined high efficient anodized aluminum heat sink incorporating a large surface area allowing components to run cooler and more efficient for maximum heat dissipation.

MIXED/MONO OPERATION

One amplifier can power an entire speaker system using passive crossovers. Left and right speakers run in stereo with a woofer bridged mono. This is a very popular configuration for low cost entry level system.

PARALLEL 8 PIN DIN AND RCA INPUTS/OUTPUTS

Amplifiers can be linked together using DIN or RCA connectors for easy connection in multi-amp systems. These new eight pin DIN connectors are fully compatible with previous ORION amplifiers, crossovers and pre-amps.

MILITARY SPEC. DOUBLE SIDED PLATED THROUGH CIRCUIT BOARDS

All ORION circuit boards are reinforced with nickel and plated through for greater reliability with through hole parts.

15 VOLT PHANTOM POWER SUPPLY FOR ORION SIGNAL PROCESSORS

On board power supplies for external processors eliminates grounding problems that can cause engine noise in the system.

COMPLIMENTARY BI-POLAR MATCHED OUTPUTS

Matched outputs have less distortion and better sound quality. Thermal stability is improved as heat is dissipated from the devices more evenly.

NO (AUDIO) CURRENT LIMITING CIRCUITRY

The amplifier will produce more power at lower impedance loads, without going into early protection.

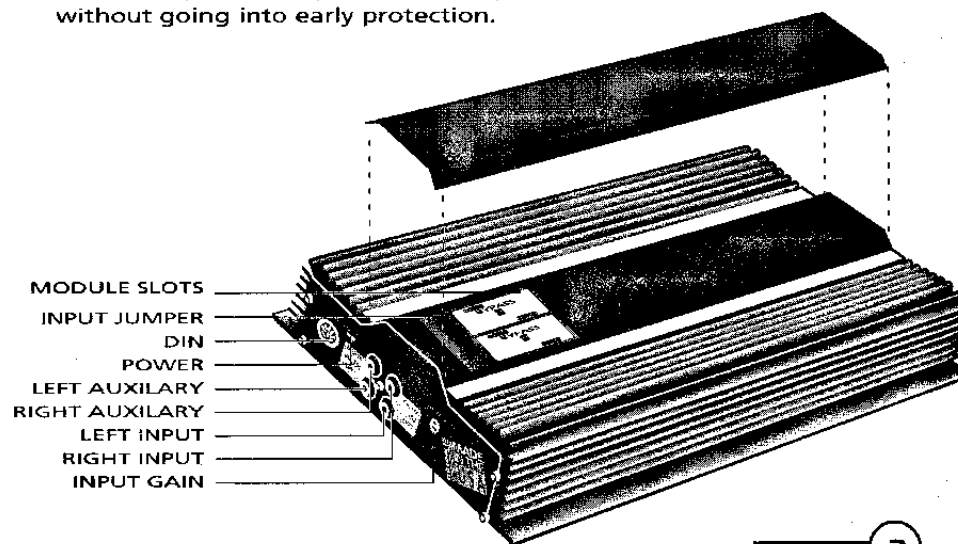

SYSTEM PLANNING

The most important part of your amplifier installation is system planning. Deciding on a system plan will determine the configuration of your signal jumpers, modules and amplifier wiring. To help you, we have included seven of the most common systems with the information necessary to configure the signal jumpers and the modules. New XTR amplifiers have the unique ability to be set up in a master/slave configuration. In this configuration, the master amplifier controls the gain of the slave amplifier(s).

SYSTEM #1

Full Range operation

One amplifier drives a pair of full range speakers. The amplifier is configured for this system from the factory.

- Amplifier output is full range.
- The lowest recommended impedance is 2Ω per channel stereo.

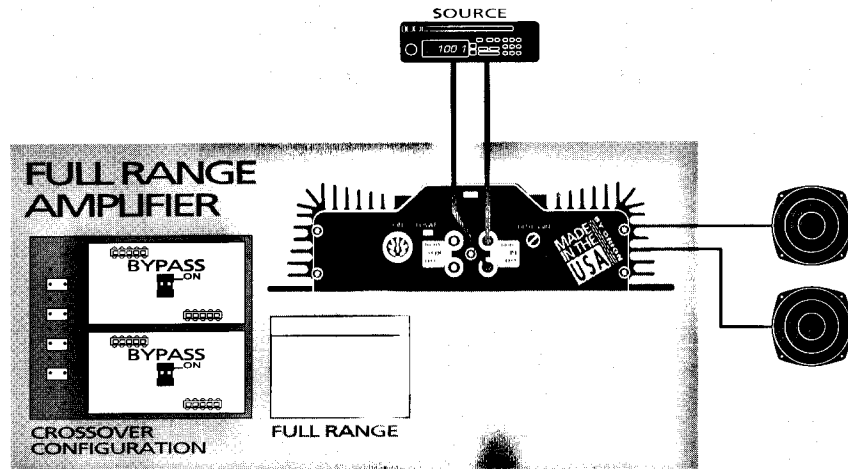

SYSTEM #2

Bridged operation with a 12 dB/octave low-pass crossover for low frequency drivers.

- Amplifier output is low-pass for woofer.
- Amplifier is configured for summed bridged mono operation.
- The lowest recommended impedance is 4Ω bridged mono.

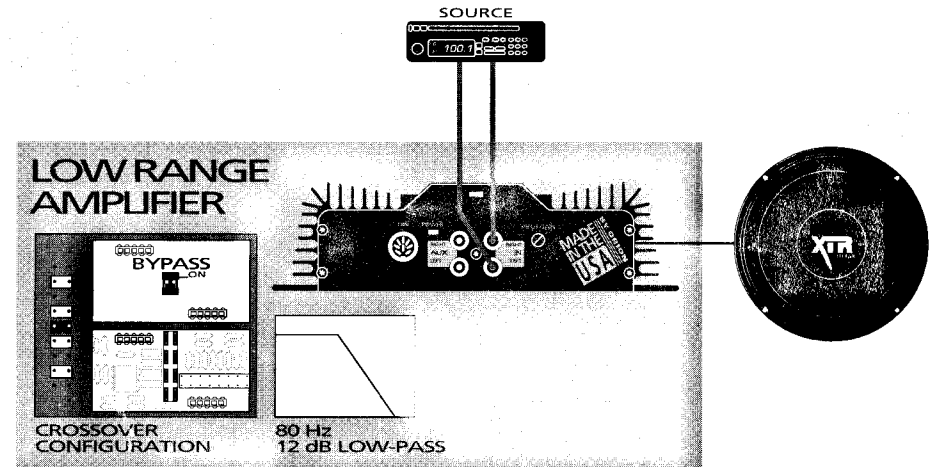

SYSTEM #3

Mixed-mono for bridged operation to the woofer and stereo operation for the left and right speakers. **Note: be sure to use the correct passive crossovers.**

- Amplifier output is full range.
- The lowest recommended impedance 2Ω per channel stereo.
- The lowest recommended impedance 4Ω bridged mono.

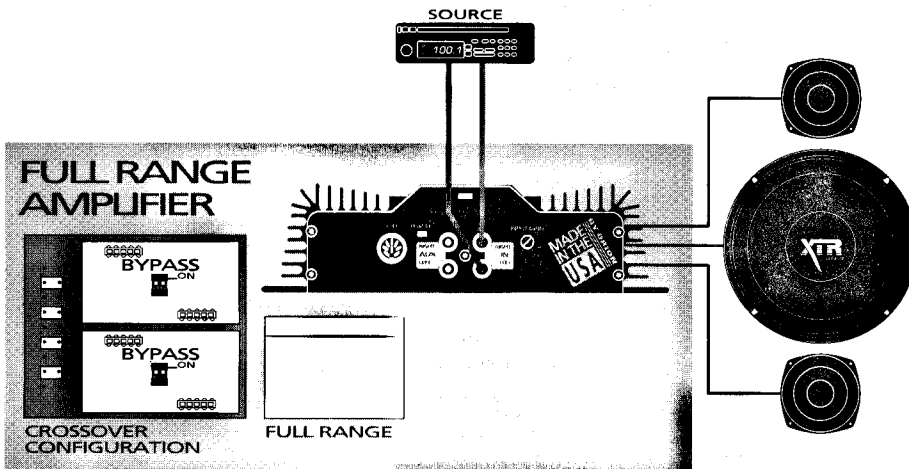

SYSTEM #4

Bi-amplified system

- The lowest recommended impedance 2Ω per channel stereo.
- The lowest recommended impedance 4Ω bridged mono.
- Master amplifier is configured for summed bridged mono operation.
- Slave amplifier is configured for high-pass stereo operation.
- Slave amplifier gain is operational.

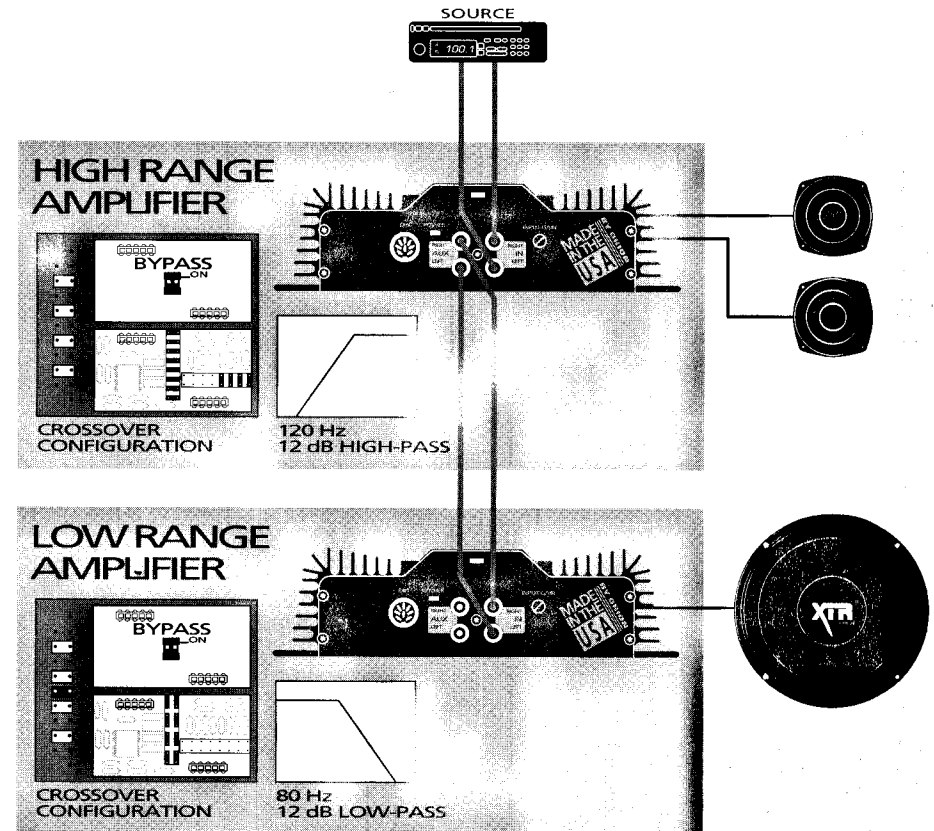

SYSTEM #5

Audiophile Bi-amplified system. This system bypasses the gain stage of the high frequency amplifier for a better signal to noise ratio.

- The lowest recommended impedance 2Ω per channel stereo.
- The lowest recommended impedance 4Ω bridged mono.
- Master amplifier is configured for summed bridged mono operation.
- Slave amplifier is configured for high-pass stereo operation.
- Slave amplifier gain is bypassed for improved signal to noise ratio.

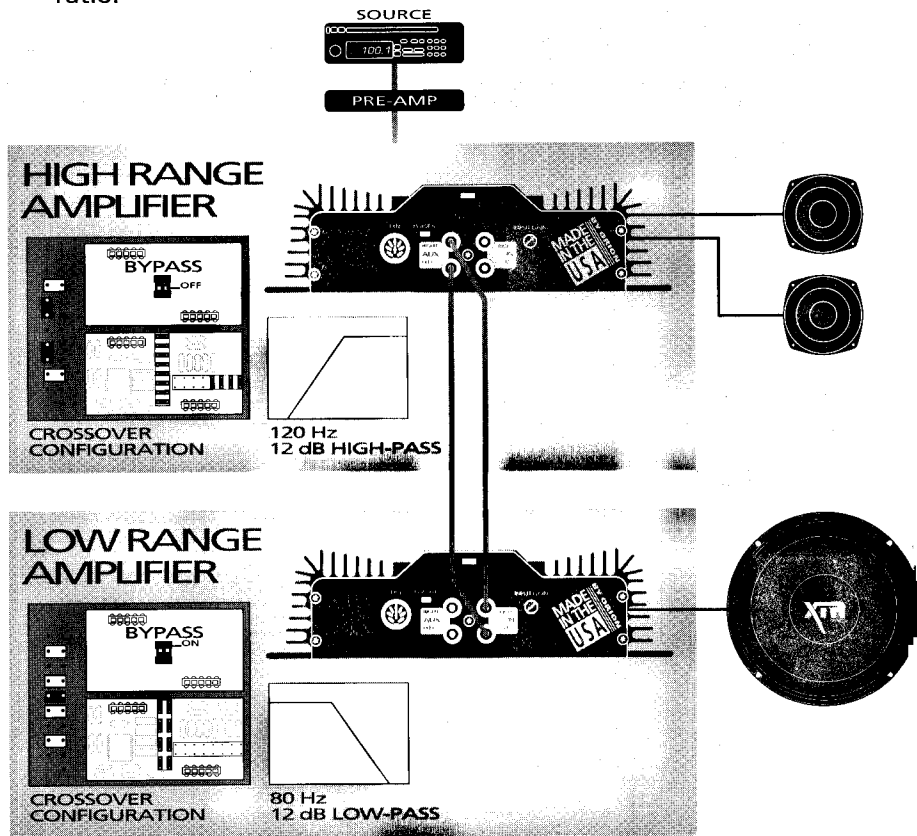

SYSTEM #6

Multiple amp system for woofers with one amplifier as the master and two slave amplifiers. The master amplifier controls the gain for the slave amps.

- The lowest recommended impedance 4Ω bridged mono.
- All amplifiers are operating in a summed bridged mono configuration.
- Slave amplifiers have both module slots and gain controls bypassed for easy system tuning and improved signal to noise ratio.

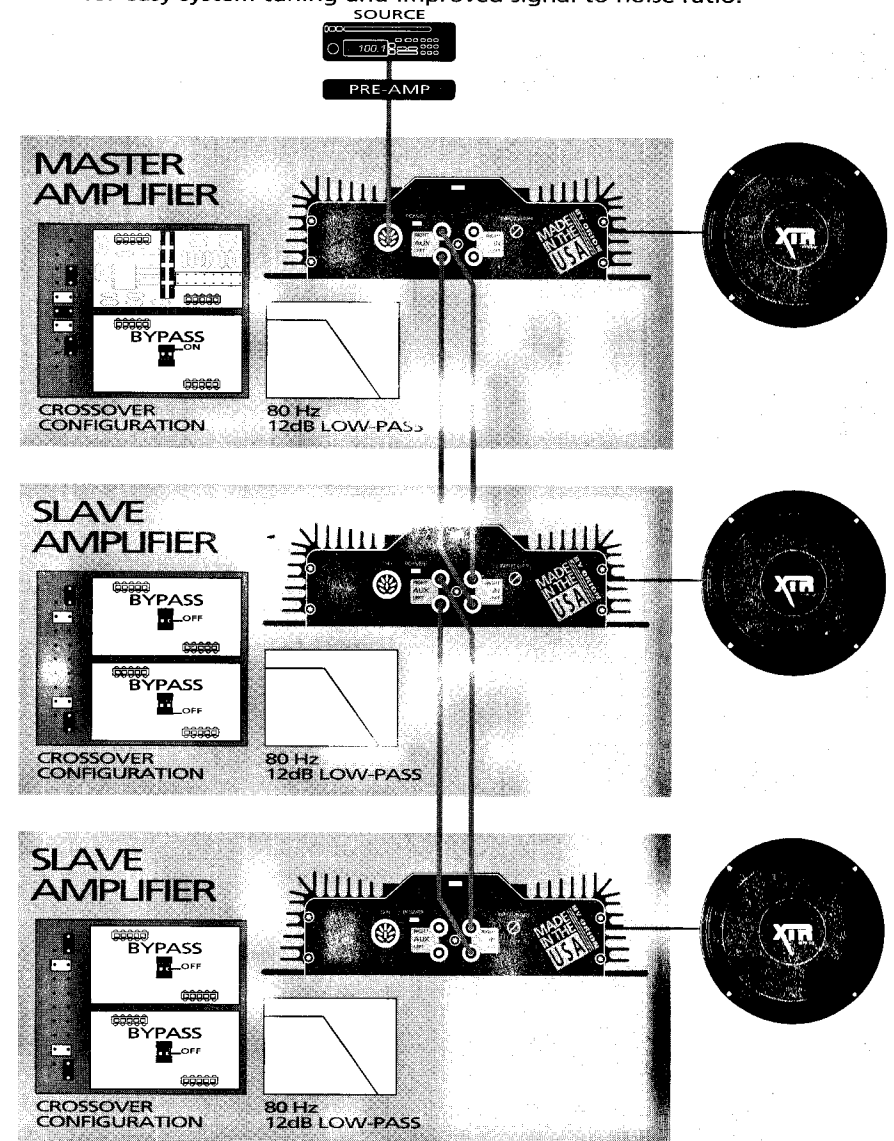

SYSTEM #7

Tri-Amped System

- The lowest recommended impedance 2Ω per channel stereo.
- The lowest recommended impedance 4Ω bridged mono.
- Master amp is configured for summed bridged mono low-pass operation.
- Slave amp 1 is configured for stereo 12dB/octave bandpass operation.
- Slave amp 2 is configured for stereo 12dB/octave high-pass operation.
- All gain controls are operational.

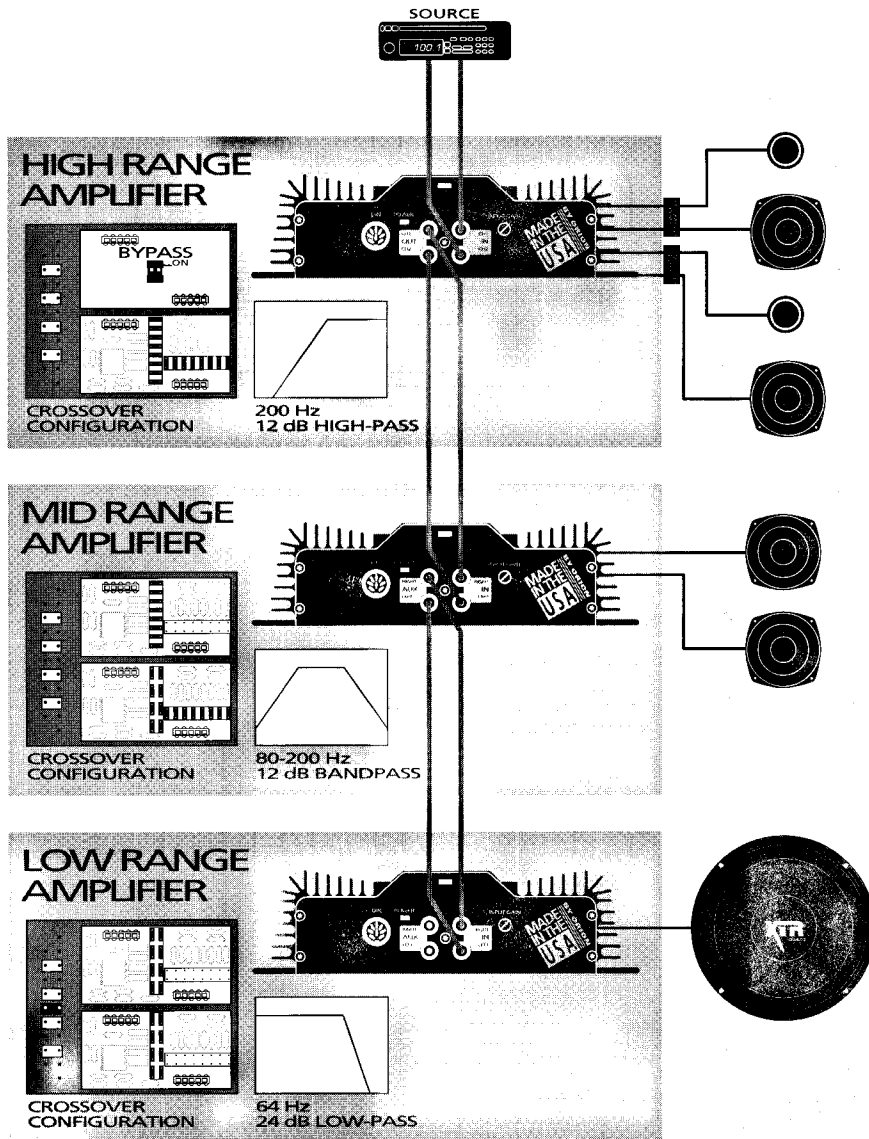

SETTING SIGNAL JUMPERS

FACTORY SETTING

Your new amplifier has two pair of RCA jacks and an 8 pin DIN connector. These can be configured using the jumper pins inside the amplifier for a variety of options. In the factory setting, RCA jacks marked "IN" are used as the input for the amplifier. The RCA jacks marked "AUX" are in parallel with input RCAs. Page 12 and 13 show 3 common configurations. Page 14 shows a configuration diagram for custom applications.

OTHER INPUT/OUTPUT OPTIONS

RCA's AUX can be an unaltered full range signal or routed through the internal module slots.

DEFAULT SETTINGS

When you take the amplifier out of the box, the amplifier operates like a standard 2 channel, full range amplifier. The default position for Input Jumpers is shown on the next page. (page 12)

⚠ CAUTION: Do not change Input Jumpers or module slots when the amplifier is turned on. Serious amplifier or speaker damage may occur

DEFAULT SIGNAL JUMPER CONFIGURATION

- RCA AUX jack is paralleled to RCA inputs.
- DIN inputs are paralleled to RCA inputs.
- DIN AUX pins are disabled.
- Internal Gain Stage is enabled.
- Both module slots are enabled.
- Amplifier is configured for stereo or stereo/mono operation.

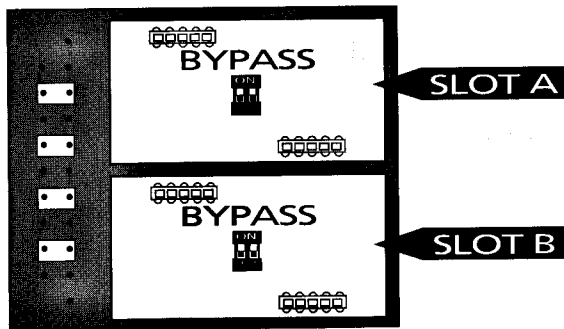

ACTIVATING FILTERS ON AUX RCAs

- Left and Right AUX RCAs are filtered through both internal module slots and gain stage.

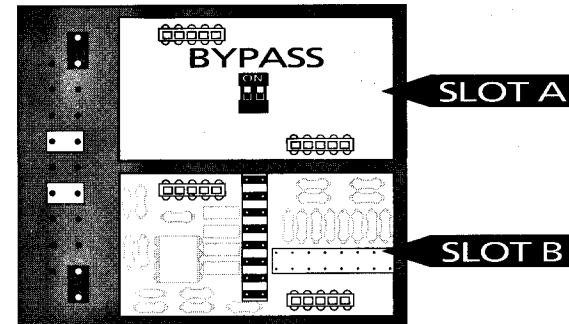

ACTIVATING SUMMED MONO OPERATION

- Adding the single jumper pictured below sums the output of the amplifier under any condition.
- Left and Right inputs are internally summed.

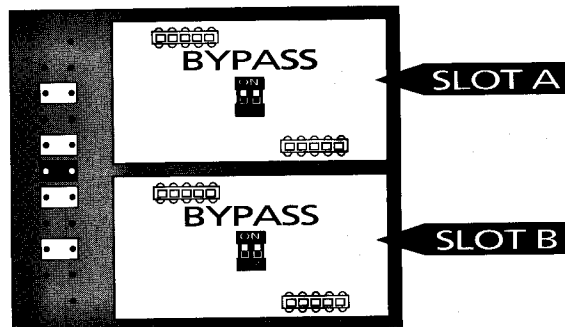

AMPLIFIER CONFIGURATION DIAGRAM

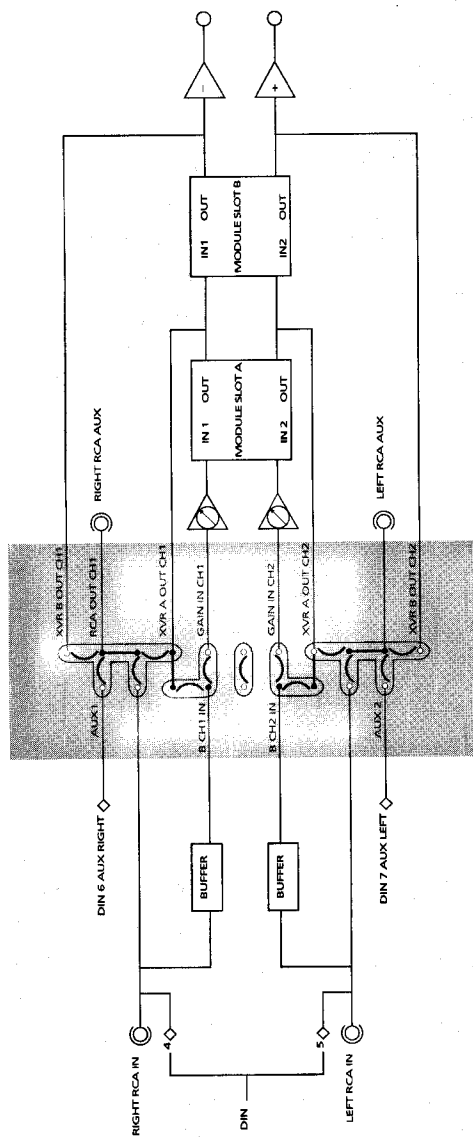

- Denotes two signal pins that can be connected.
- Denotes two signal pins that are internally connected.

CROSSOVER CONFIGURATION USING CROSSOVER MODULES

The ORION HCCA Series amplifiers have two module slots in series that can be used for crossovers and other future modules.

* The HCCA Series amplifiers are shipped with two bypass modules installed. In default operation, the amplifier output is full range (see figure 1).

Included with the amplifier is an additional module which can be installed in either slot depending on the system configuration desired. The SLF-1 (Selectable Low Frequency-1 slot size) module can be configured for either high or low-pass 12 dB per Octave filter operation. It has four selectable frequencies: 80Hz, 120Hz, 160Hz and 200Hz. The modules have unidirectional mounting capability. This means the module can be correctly installed either right-side up or up-side down without affecting its operation.

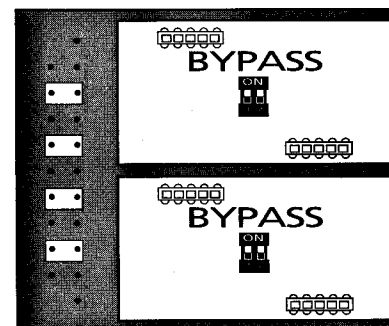

Full range (fig1)

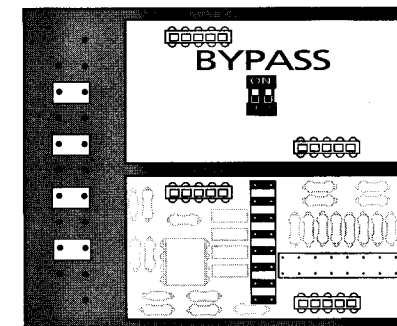

12 dB/oct High-pass

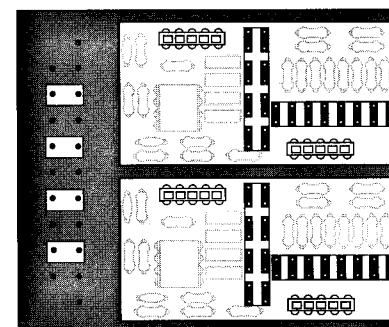

24 dB/oct Low-pass

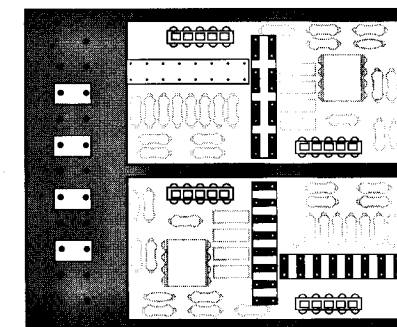

12 dB/oct Bandpass

Listed below are the eight possible configurations when using the SLF-1 crossover module.

- The module slots are configured in series, this amplifier has the capability of 12 dB/octave high-pass, low-pass, or bandpass operation. 24 dB octave high-pass or low-pass operation is also possible. An additional module is required for bandpass or 24 dB per octave operation.

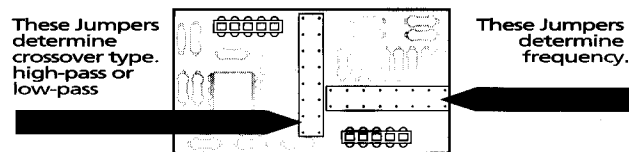
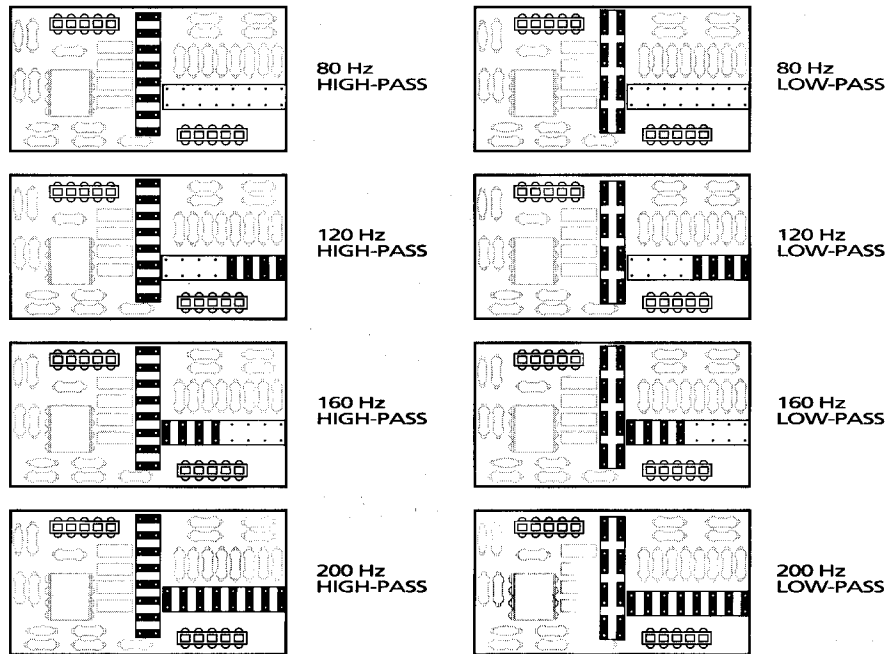

Note: When two low-pass filters of the same frequency are used for 24 dB per octave operation, the cut off frequency will decrease by 20 percent.

When two high-pass filters of the same frequency are used for 24 dB per octave operation, the cut off frequency will increase by 20 percent.

INSTALLATION

This section details the mechanical and electrical procedures you will need to perform the installation of your ORION amplifier. Take a moment to look over the list of precautions, tools and additional parts needed to successfully complete the job.

GENERAL PRECAUTIONS

Before installation, make sure you pick a location that will provide adequate ventilation around the amplifier. The ORION amplifier has massive heatsink fins to couple generated heat to surrounding air space via thermal conduction. However, if the amplifier is mounted in a tight space without any air movement, over time the amplifier can fail, in spite of its thermal protection circuits.

Therefore, we recommend that you mount the amplifier flat on the floor under the front seat or in the trunk. Remember, heat travels up away from the heatsink fins. In addition, please observe these precautions:

- Do not enclose the top of the amplifier unless you have a cooling fan.
- Direct cool air along the length of the fins, rather than across them, for the most efficient cooling. Remember, any moving air will dissipate heat.

REQUIRED TOOLS

- Electric drill/drill bits
- Utility knife
- Phillips and flathead screwdrivers
- Pliers (standard and needle nose)
- Wire cutters/strippers
- Wire crimping tool
- Wire brush and emery sandpaper (for metal)
- Rubber grommets
- Heat shrink tubing
- Soldering iron and solder
- Nylon tie wraps
- Volt/Ohm meter (VOM or DVM)
- Felt-tip pen or spring loaded center punch tool

REQUIRED PARTS

Included-

- Four mounting screws
- Power/ground plug
- Speaker plug
- Fuse

Not Included-

- Power wire
- Remote turn on wire
- Battery fuse
- RCA/DIN input cables
- Speaker cable
- Battery terminals

OPTIONAL PARTS

ORION's accessory company carries everything you need to complete your car audio system.

- MBR 70 Multiple Battery Regulator
- Audio Interlink Cables (RCA & DIN)
- Modular Power Distribution (POWER BLOCKS)
- Passive Crossovers
- Modular Fuse Holders (POWER BLOCKS)
- Raw Crossover Components
- Speaker Cable
- Automotive Carpet, Vinyl & Grill Cloth
- Power Cable, Ground Cable
- Damping Material
- Battery Terminals



AMPLIFIER WIRING

1. Disconnect the vehicle's battery negative (-) terminal before making any power connections.
 2. Reinforce the battery ground: Use an 8 gauge wire ground to ensure an adequate ground (See Detailed Power Connections.)
 3. Connect the power cable directly to the positive (+) terminal
CAUTION: DO NOT connect amplifier power wire to fuse box.
 4. Use a fuse within 18 inches of the battery.
 5. Make sure that all connections are clean and properly secured. (Failure to do so may result in damage to the components in the system.)
 6. Make sure the power wire enters the vehicle safely. Always use a grommet when routing wire through metal.
 7. Run wire through the vehicle in appropriate areas. Avoid power routing wires near the fuse box or other audio cables and sensitive electronics (They can radiate noise into your power wire). Never get power from the fuse box, this can cause noise problems and other electrical problems.
 8. Once you have selected the mounting location, mount the amplifier using the four self-tapping screws provided. Tighten screws securely.
-  **CAUTION: Do not drill into the fuel tank, fuel lines or through electrical wiring!**
9. Connect power wire to the power plug supplied with the amplifier to the chassis of the vehicle. Make sure connection is short and secure as possible.
 10. Ground the amplifier. Be sure the ground is secure to prevent power loss due to resistance caused by a poor ground.
 11. Make speaker connections. Do not allow the speaker leads to come in contact with each other, or to ground when the amplifier is on. This will cause a noise problem, and may cause internal damage to the amplifier.

12. Connect the signal cables to the amplifier.
13. Connect remote turn-on lead. This wire needs (+)12 volts input to turn on the amplifier.
14. Make necessary gain adjustments.

POWER AND SPEAKER CONNECTIONS

Power and ground connection is made via the 8 ga. power connector. The ground wire should be as short as possible and grounded to the chassis of the vehicle. Do not use a self tapping screw for the ground connection. A loose connection can cause resistance in the circuit and overheat the amplifier. A bolt, nut, and washers are recommended.

SPEAKER CONNECTIONS

Speaker connections are made using the 12 ga. speaker connector. The connector is marked for left and right speakers, positive and negative terminals.

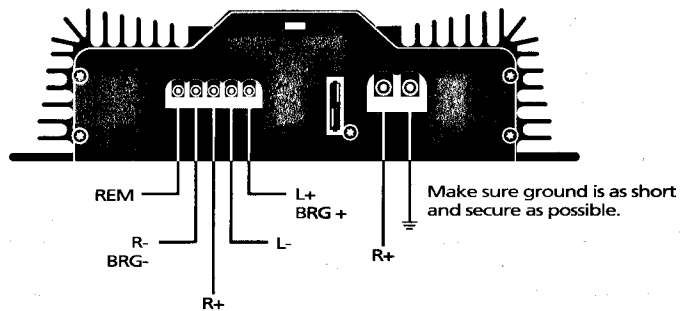

POWER CONNECTIONS

- 8 gauge wire used for both the power and ground wire.
- Fuse holder as close a possible to the battery, less than 18"
- Add additional ground wire to battery equal to the power wire used for B+ of the amplifier.

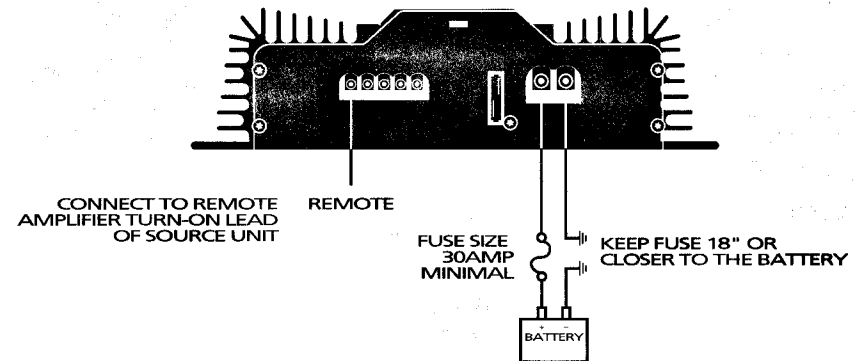

STEREO WIRING

- The lowest recommended impedance 2Ω per channel stereo.

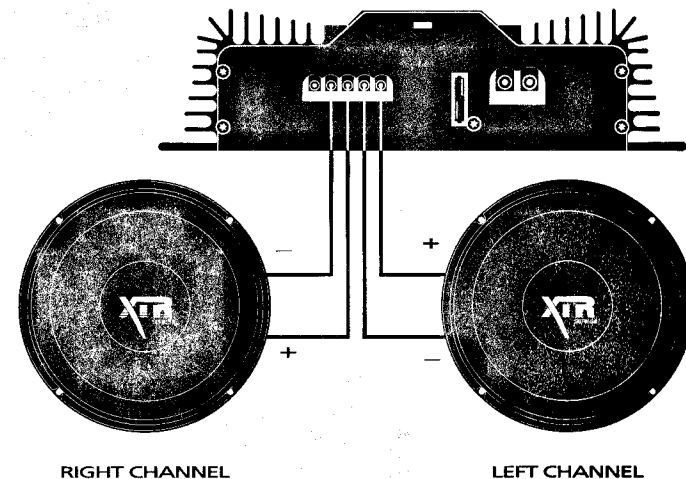

BRIDGING

All ORION amplifiers can be bridged by combining the power from the left and right channels to have one channel of amplification. The output capability is normally double the amount of a single stereo channel. ORION amplifiers can be bridged to a single mono channel or mixed-mono.

MONO MODE 1 CHANNEL

Use the right negative and the left positive speaker outputs.

Note: Any time you bridge an amplifier, each channel "sees" half the impedance of the speaker load. For example if you bridge a single 4 ohm speaker the amplifier will "see" a 2 ohm stereo load. In this configuration we recommend that you sum the left and right inputs to mono. (see page10)

MIXED-MONO

In this configuration, the woofer is run in mono and the left and right speakers are in stereo. The stereo speakers are wired normally and the woofer is wired using the right negative and left positive speaker terminals. (See page10) Be sure to use the correct passive crossovers when using this configuration. Capacitors are needed for the left and right speakers and a coil is needed for the woofer.

CAUTION: Passive crossover frequency should not overlap. Failure to do so make cause damage to amplifiers and load speakers.

MONO MODE 1 CHANNEL WIRING

- Output can be configured left, right or mono output.
- The lowest recommended impedance is 2Ω bridged mono.

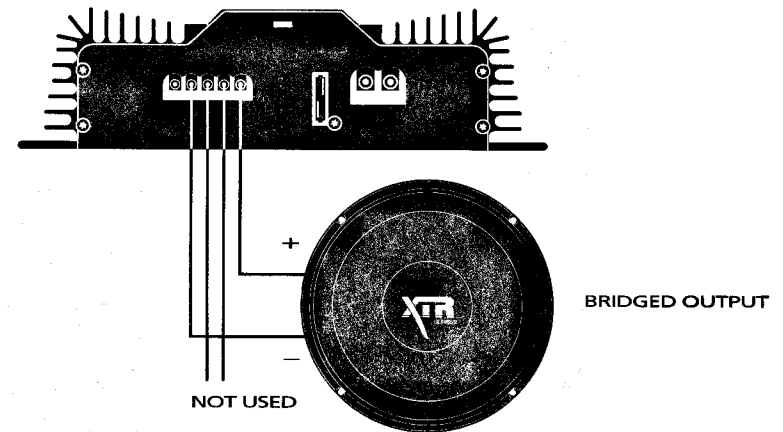

MIXED MONO WIRING

- Passive Crossover Frequencies must not overlap!
- The lowest recommended impedance is 2Ω per channel stereo.
- The lowest recommended impedance is 4Ω bridged mono.
- Amplifier output set to full range.

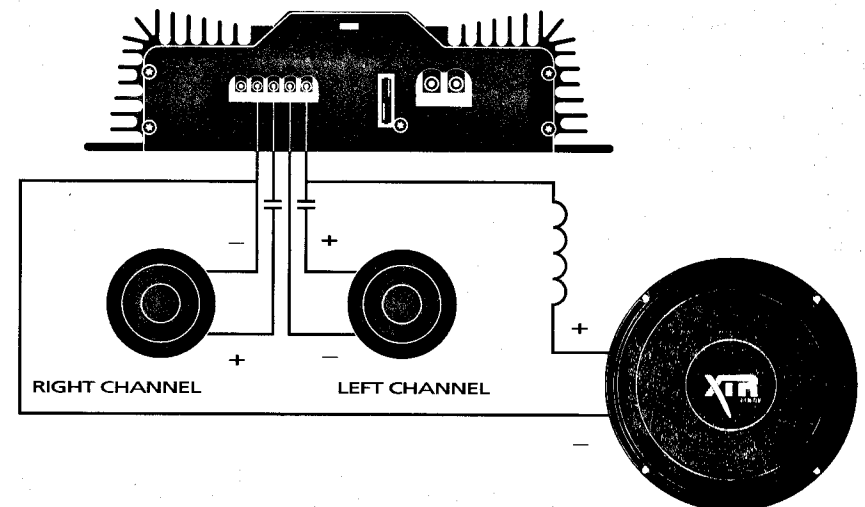

WHAT TYPE OF INPUTS AND OUTPUTS CAN BE USED?

- There are three different ways you can get signal to your amplifier: RCA, DIN and High Level Input. Regardless of your source unit, ORION has provided an input configuration to maximize the performance of your system. You can also use different combinations of RCA, DIN and High Level Inputs and Outputs. Listed are different ways to get audio signal in and out of your amplifier.

RCA INPUTS AND OUTPUTS CONFIGURATION

- RCA signal input range to make full power: 150mV RMS to 5 V RMS.
- RCA left and right inputs are the main inputs for the amplifier.
- RCA's AUX are programmable. See Setting Signal Jumper section of this manual.
- Maximum RCA output 8 V RMS when using internal gain stage.

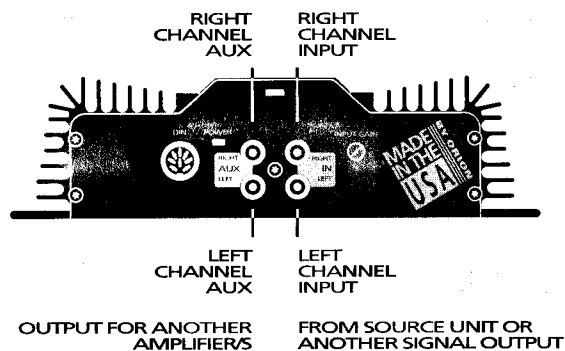

DIN INPUTS, OUTPUTS AND PHANTOM POWER

- DIN signal input range to make full power: 150mV RMS to 5 V RMS.
- DIN AUX is programmable.
- Maximum DIN output 8 V RMS when using internal gain stage.
- 15 Volt Rails can supply "Phantom Power" to ORION accessories.
- Ground is used for power ground for Phantom Power and audio ground for both DIN audio input and outputs.

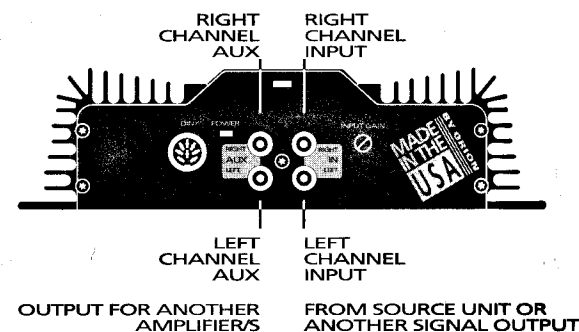
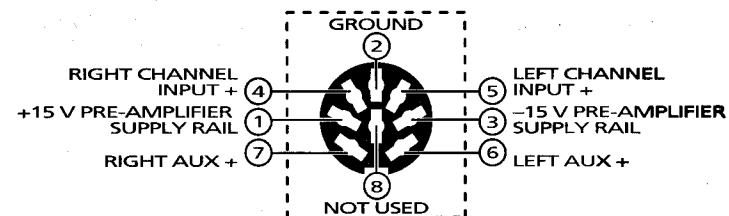

SYSTEM ADJUSTMENTS

You will get less system noise if you keep the amplifier gain as low as possible. This can be accomplished best with a preamp, such as the ORION 300 PRQ, 300 PHD or 300 PSW.

If there are no accessories (equalizers, crossovers, etc.) used in the system:

1. Turn off all power.
2. Set the Gain controls on all amplifiers to their minimum position.
3. Turn on the power to the amplifiers. Turn on the radio and set the Volume control to approximately 3/4 volume.
4. Adjust the Gain control on each amplifier until the system is at full output, just below clipping.
5. Set the Volume control on the radio for desired listening level.

If ORION accessories are being used:

1. Turn all power off.
2. Set the gain controls on all amplifiers to their minimum positions.
3. Set all frequency controls on the 300 PRQ Equalizer to flat response (dots in top center position). If a 300 PHD or 300 PSW is being used, set both frequency controls, and the boost/cut controls to the center position.
4. If a 300 PRQ, PHD or PSW is being used, set both input controls to minimum (fully counterclockwise) and the volume control to maximum (fully clockwise).
5. Turn on power to amplifiers. Turn on the radio and set the Volume control for approximately 3/4 volume.
6. Adjust each input gain control on the pre-amp until the system is at full output just below clipping. If the input gain controls on the pre-amp do not produce full volume, increase the gain setting of each amplifier as required to realized full output. Decrease the setting of the Volume control on the 300 PRQ to desired listening level.



CAUTION: Be Sure To Turn Off The Power When Disconnecting And Re-connecting Cables.

TROUBLESHOOTING GUIDE

This section provides you with a catalog of amplifier symptoms and their probable causes and solutions. Before you consult this listing, make sure the vehicle's electrical system is working properly by verifying that other electrical items (e.g. headlights, windows, etc.) still function correctly.

Symptom	Probable Cause	Solution
No Audio	Low or No Remote Turn-On connections	Check remote turn-on voltage at amp and head unit
	Blown Fuse	Replace with new fast-blow fuse
	Power wires not connected	Check butt splices or solder joints; check Ground and Battery connections
Audio cycles on and off	Blown speakers or not connected	Use VOM or DVM to measure speaker coil impedance; check speaker wiring connections
	Thermal Protection Circuits are properly shutting amplifier off each time it gets too hot	Check location for adequate ventilation; check speaker wiring for a short to chassis
Distorted Audio	Input Sensitivity not set properly or damaged speaker cones	See Calibrating Input Sensitivity procedure and check each step; inspect each speaker for damage and repair or replace suspected component
	Low turn-on voltage	Refer to head unit owner's manual
Audio level low	Mute circuit is on	Check electrical system for low voltage; check speaker ground connection
Poor bass response	Speakers wired with wrong polarity, causing cancellation of bass frequencies; low voltage	Check polarity of wires from amplifiers to each speaker as defined by the system; check battery connections
External fuse blowing	Incorrect wiring or short circuit; abuse; damaged speakers	Refer to Electrical Installation and check each installation step

SPECIFICATIONS

Model	XTR 250	XTR 275	XTR 2150
Output Power per channel, all channels driven into 4 Ω @ 12 V	50 x 2	75 x 2	150 x 2
Distortion maximum at 4 Hz, 20 to 20kHz	0.03%	0.03%	0.03%
Frequency Response ±0.5 dB	100dB	100dB	100dB
Signal to Noise	10,000 Ohms	10,000 Ohms	10,000 Ohms
Input Impedance	150mV to 5 Volts	150mV to 5 Volts	150mV to 5 Volts
Input Sensitivity	2Ω to 8Ω	2Ω to 8Ω	2Ω to 8Ω
Output Load (stereo)	20 Amps to 30 Amps	25 Amps to 35 Amps	30 Amps to 40 Amps
Current Draw	30 Amp ATC	40 Amp ATC	2 x 30 Amp ATC
Fuse Size	Greater than 200	Greater than 200	Greater than 200
Damping Factor	30 Volts per μsec	30 Volts per μsec	30 Volts per μsec
Slow Rate	70dB	70dB	70dB
Stereo Separation	Selectable via Signal Jumper. Default settings Bypass, Full Range	Selectable via Signal Jumper. Default settings Bypass, Full Range	Selectable via Signal Jumper. Default settings Bypass, Full Range
Input/Output & Module Slot configuration			
Crossover Settings	Selectable via Crossover Signal Jumpers	Selectable via Crossover Signal Jumpers	Selectable via Crossover Signal Jumpers
Bridgeable	Internal Mixed & Summed (Selectable via Signal Jumpers)	Internal Mixed & Summed (Selectable via Signal Jumpers)	Internal Mixed & Summed (Selectable via Signal Jumpers)
Size (LxWxH)	7" x 8 1/2" x 2 1/4"	7" x 8 1/2" x 2 1/4"	7" x 8 1/2" x 2 1/4"

WARRANTY & SERVICE

ORION Industries, Inc. (hereafter ORION) warrants this product to be free from defects in material and workmanship under the following terms:

PARTS and LABOR are warranted for a period of (2) years from the date of the first consumer purchase from an Authorized ORION Dealer. Except as specified below, this warranty covers ALL defects in material and workmanship in this product. The following are NOT covered by this warranty:

- Any product which is NOT purchased from an Authorized ORION Dealer. If you are uncertain as to whether your dealer is authorized, please contact ORION at (602) 730-8200. In countries other than the USA, each distributor warrants the ORION products which it sells. (If product is purchased from a non-authorized dealer, the warranty is 90-days from date of purchase).
- Any product on which the serial number has been defaced, modified or removed.
- Damage or malfunction resulting from;
 - accident, misuse, abuse, unauthorized modification or failure to follow the instructions provided with the product
 - repair by anyone NOT authorized by ORION
 - damage due to shipping (these claims must be presented to the freight carrier)
 - removal or installation of the product
 - any failure that has NOT been caused by a defect in material or workmanship

This warranty is in effect for the original purchaser only. ORION will pay for labor and material expense for covered items. ORION does not cover removal or installation charges, payment of shipping charges to ORION, payment of OUT-OF-WARRANTY shipping charges, or damage to other property caused by any defects in this product.

To obtain service, take or ship the product (pre-paid) in its original packaging, if you do not have the original packaging the product must be packed so no damage will be incurred by the product during its shipment to:

Orion Industries
9235 S. McKemy
Tempe, AZ 85210
(480)705-5600

For IN-WARRANTY service you must include a copy of the original, dated sales receipt, including serial number, from an Authorized ORION Dealer. Please also enclose your name, return street address (No P.O. Boxes) and a detailed description of the problem.

Exclusion

- This warranty is in lieu of all other warranties expressed or implied.
- In no event will ORION be liable for any consequential damages resulting from use of the products or any defect in the product.

This Warranty gives you specific legal rights and you may also have other rights which vary from state to state.

HIGH PERFORMANCE CAR AUDIO
AMPLIFIERS, SIGNAL PROCESSORS
AND LOUDSPEAKERS.
MADE IN THE USA.

**MADE
IN THE
USA**



ORION

HIGH PERFORMANCE CAR AUDIO

© 1995 Orion Industries, Incorporated

Orion Industries
9235 S. McKemy
Tempe, AZ 85210
(480)705-5600