

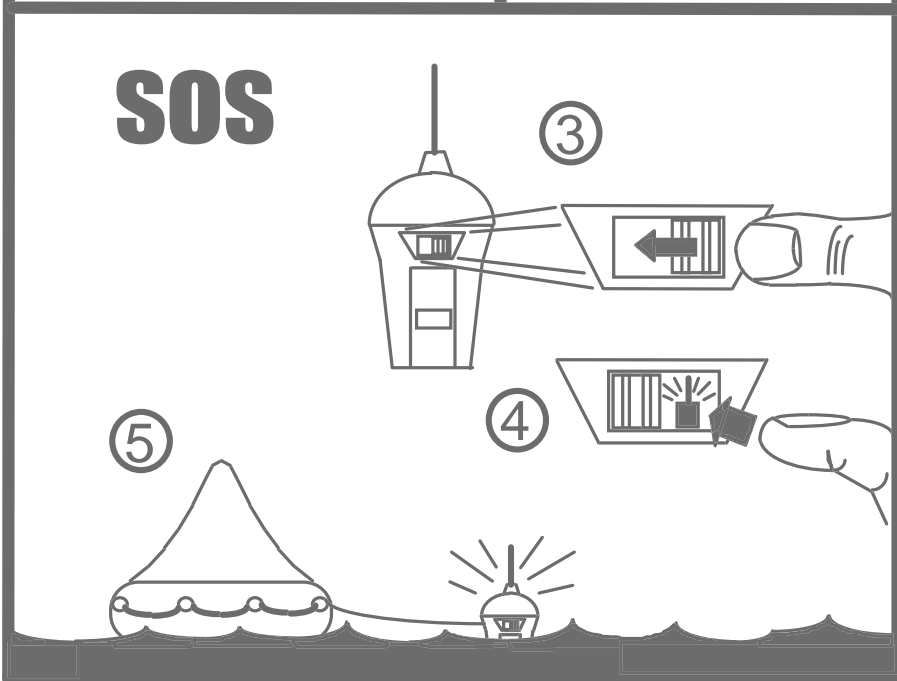

# OWNERS MANUAL

**McMurdo**  
*Marine*

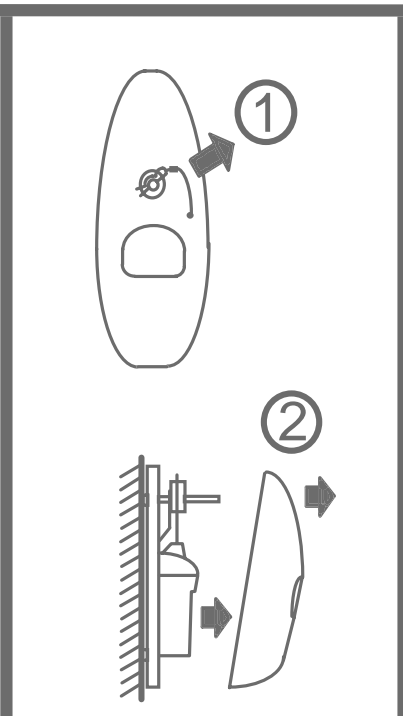
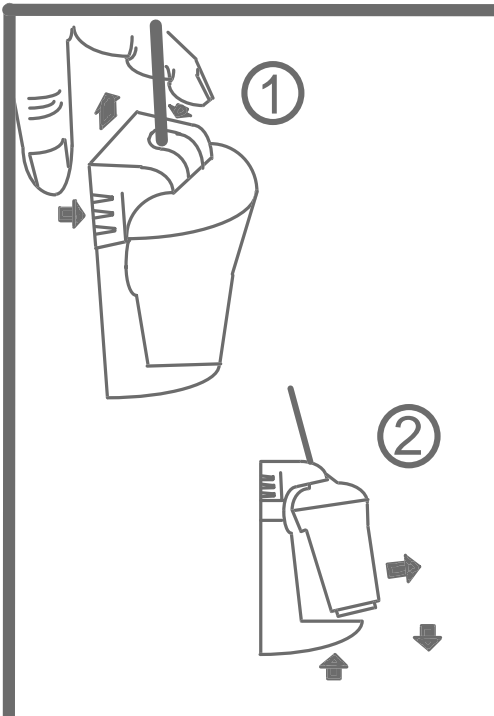

<b>1</b>	<b>Warnings</b>	<b>2</b>
<b>2</b>	<b>Introduction</b>	<b>3</b>
2.1	COSPAS-SARSAT satellite system	3
2.2	Global Positioning System (GPS)	4
<b>3</b>	<b>Purpose</b>	<b>5</b>
<b>4</b>	<b>Description</b>	<b>6</b>
4.1	Wall bracket	6
4.2	Float-free enclosure	7
4.3	Manual G4 in enclosure	8
<b>5</b>	<b>Controls</b>	<b>9</b>
5.1	ON button	9
5.2	READY button	9
5.3	Sea switch	9
5.4	Lamps	10
<b>6</b>	<b>Operating procedure</b>	<b>11</b>
6.1	Sinking	11
6.2	Abandon ship	11
6.3	Releasing G4 from a wall bracket	11
6.4	Releasing G4 from an enclosure	12
6.5	Manual activation	12
6.6	Deactivation	13
6.7	Battery condition	13
6.8	Re-fitting G4	13
<b>7</b>	<b>False alarms</b>	<b>15</b>
7.1	Stand down rescue services	15
7.2	De-activate the EPIRB	15
7.3	Dealing with a transmitting G4	16
<b>8</b>	<b>Wall bracket installation</b>	<b>17</b>
8.1	Siting	17
8.2	Mounting procedure	17
8.3	Mounting instruction plate	18
<b>9</b>	<b>Enclosure installation</b>	<b>19</b>
9.1	Siting	19
9.2	Mounting procedure	19
9.3	Mounting instruction plate	20
9.4	Marking HRU expiry	20
9.5	Marking vessel name	21
<b>10</b>	<b>Registration</b>	<b>22</b>
10.1	Overview	22
10.2	How to register	22
10.3	Warranty form	22
10.4	Radio licence	23
10.5	Sale or transfer	23
<b>11</b>	<b>Maintenance</b>	<b>24</b>
11.1	Monthly self-test & inspection	24
11.2	HRU replacement	25
11.3	Battery replacement	26
11.4	Servicing	26
11.5	Transportation	26
11.6	GMDSS inspections	26
<b>12</b>	<b>Fully disabling a G4</b>	<b>27</b>
<b>13</b>	<b>Technical specification</b>	<b>28</b>

# **1 WARNINGS**

- **This EPIRB is an emergency device for use only in grave and imminent danger.**
- **False alarms cost lives and money. Help to prevent them; understand how to activate and disable your equipment.**
- **Read the complete manual before installing, testing or using the EPIRB.**
- **Ensure the EPIRB is registered with your local authorities (Flag State nation).**
- **The EPIRB contains no user servicable parts. Return to your dealer for battery replacement or other service. Do not open.**
- **Dispose of this device safely. Contents include Lithium batteries; do not incinerate, puncture, deform or short-circuit.**
- **This device emits radio frequency radiation when activated. Because of the levels and duty cycles, such radiation is not classed as harmful.**
- **Do not stare at strobe.**

## 2 INTRODUCTION

### 2.1 COSPAS-SARSAT satellite system

The COSPAS-SARSAT system provides distress alert and location information to search and rescue authorities anywhere in the world for maritime, aviation and terrestrial users in distress.

There are two satellite arrays carrying the COSPAS-SARSAT system. The principal array is LEOSAR (Low Earth Orbit Search and Rescue) which has seven satellites in polar and near-polar orbits. The orbits of these satellites are arranged to scan the entire surface of the Earth; on average, a satellite comes into view every 45 minutes.

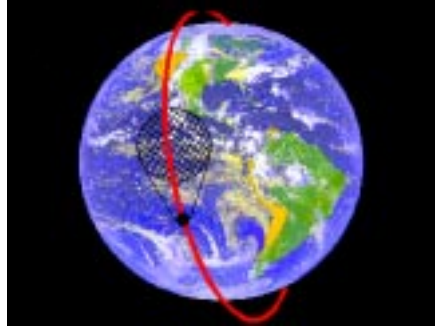

*LEOSAR satellite path and scan footprint*

Distress transmissions from EPIRBs are picked up by the satellites and retransmitted to ground receiving stations, which then pass the message to the appropriate rescue organisation. On average, the total delay from activation of an EPIRB to the message being received by the rescue services is 90 minutes.

COSPAS-SARSAT is in an advanced stage of commissioning the second satellite array, GEOSAR (Geostationary Search and Rescue). This array uses geostationary satellites which are always in view (over their area of coverage), so that reception of the EPIRB signal is instantaneous.

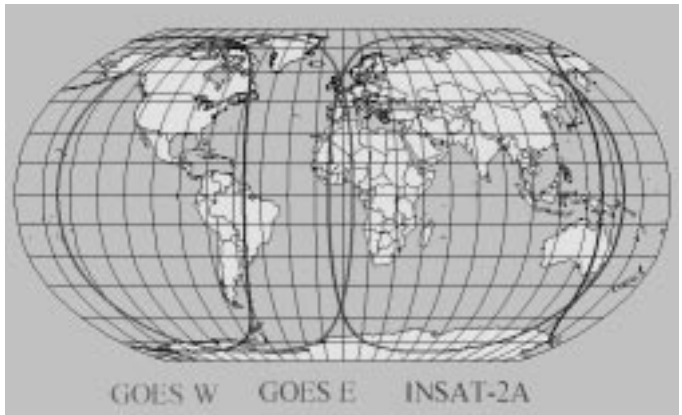

*GEOSAR coverage*

## 2.2 Global Positioning System (GPS)

The GPS system is a satellite array which enables a receiver located anywhere on Earth to determine its exact position, usually to within 100m.

The array uses 24 satellites (plus spares) orbiting the Earth in six orbital planes, four satellites per plane, as shown below. These are arranged so that at least five satellites are within range of any receiver (which can be anywhere) at all times.

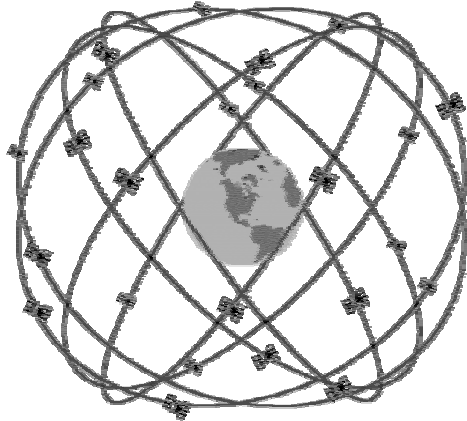

*GPS satellite orbital planes*

Each satellite transmits information which enables its position and distance from the receiver to be calculated. By combining these data for multiple satellites, the exact position of the receiver can be determined.

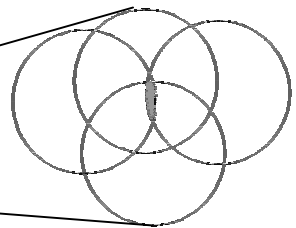
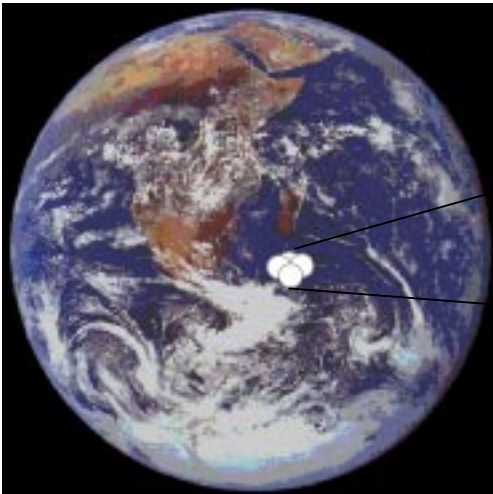

*Operation of GPS receiver  
(size exaggerated for clarity)*

### 3 PURPOSE

An Emergency Position Indicating Radio Beacon (EPIRB) is used to alert search and rescue services in the event of an emergency. It does this by transmitting a coded message on the 406MHz distress frequency. This message is relayed via satellite and earth station to the nearest rescue co-ordination centre.

The satellite system is run by COSPAS-SARSAT, and has already been described. With the geostationary satellite section being commissioned, the alerting delay is reduced from typically 90 minutes to a few minutes within the geostationary satellite coverage.

Instant alerting is good news, but they still need to know where you are. The advantage of the G4 EPIRB is that it has a built in GPS receiver, so within minutes of activation it will have determined your latitude / longitude coordinates and will have transmitted these to the rescue centre. The position fix is accurate to 150m\*.

To operate properly the G4 needs a clear view of the whole sky. If its view is blocked and it is unable to get a position fix, then the system defaults to using a polar orbiting satellite to determine position. In this case, there is typically a 45 minute delay before the position is known and the accuracy is limited to within 5km (3 miles). This is the original system that standard (non-GPS) EPIRBs use. To get the full advantage of the G4 it is important to give it a clear view of the whole sky.

The G4 transmits a message that identifies the exact vessel to which it was registered. Knowing which vessel is in distress allows the rescue services to eliminate false alarms and launch an appropriate rescue.

The G4 also has a secondary distress transmitter. This transmits on 121.5MHz and is used for "homing" purposes. When the rescue services get close, this allows them to direction find on the signal. To cater for searches at night, the G4 has a bright flashing light that aids final visual location.

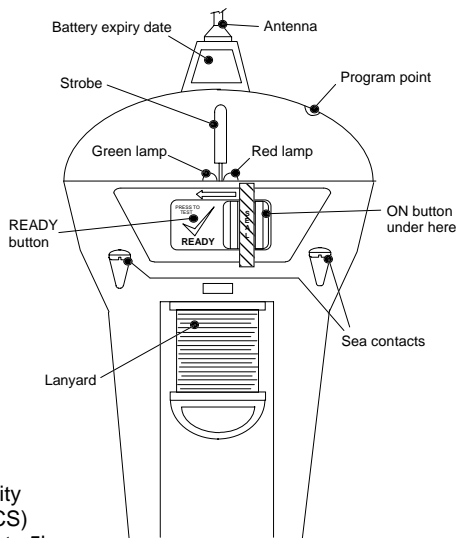

\* If the programmed identity is a Radio Call Sign (RCS) then accuracy is limited to 5km

## 4 DESCRIPTION

The G4 is a powerful self-contained distress transmitter. It is powered by a light weight Lithium battery that has a replacement interval of 5 years. An EPIRB is intended to be a one-shot device; once activated it can operate for at least 48 hours. It operates best while floating in water, but it can also be operated while on board or in a liferaft.

Referring to the previous figure, the key components of your G4 are as follows:

Antenna	This is a flexible whip. It must be near vertical when operating. If the antenna gets bent, gently straighten it out.
Strobe light	This is the glass U-tube visible through the clear lens dome. When the G4 is activated this will flash every few seconds.
Red lamp	Visible through the clear lens dome at the rear of the G4. This stays on or flashes to show you which mode you are in.
Green lamp	This flashes when the GPS gets a position fix.
Program point	A dimple in the clear dome, through which your supplier can optically input the coded message unique to your G4. You <b>must</b> register the coded message with local authorities.
READY button	Press this key once to de-activate the G4. Hold it down to run the built-in self-test, which checks basic operation.
ON button	Press this key to activate the G4 manually. The key is protected by a sliding door which is fitted with a tamper seal.
Sea switch	The two screw heads below the keys are sea switch contacts. Submerge these in water to automatically activate the G4.
Lanyard	Pull the lanyard spool down to free it. Use the cord to tether the G4 to a survival craft. <b><u>Never</u></b> tie the G4 to your vessel.

### 4.1 Wall bracket

If you purchased the manually activated version (G4m), this is normally supplied with a wall mounting bracket (see section 8). The bracket is made from white plastic so it will not rust. Its top section is sprung loaded, so that one simple squeeze will quickly release the G4 allowing it to be carried to a liferaft. The wall bracket should be sited in plain view near an emergency exit. This bracket is more than just a stowage point, it contains a magnet which disarms the G4's sea switch. If you do not stow the G4 in its bracket, there is a risk of the G4 activating if it gets wet.



## 4.2 Float-free enclosure

If you purchased the automatically activated version (G4a), also known as the “float-free” version, then your G4 is supplied in a plastic enclosure (see section 9). This is much more than just a protective housing, it contains a sprung loaded lever which automatically pushes the enclosure lid off and releases the G4 if your vessel sinks. This automatic ejection is controlled by a device called a Hydrostatic Release Unit (HRU). If the enclosure is submerged then before it reaches 4 metres (13 feet) deep the HRU cuts a plastic rod that holds back the spring and the lid is ejected, releasing the EPIRB which floats to the surface and switches on automatically.

The diagram below illustrates the automatic release sequence:

1. As the vessel sinks, the enclosure fills with water. The HRU contains a blade which is released due to water pressure acting on a diaphragm. Before it reaches a depth of 4 metres, the HRU will operate and cut the plastic rod, releasing the coil spring.
2. The spring pushes the G4 and the enclosure lid outwards. As the lid pivots off it disengages from the screw head that helped hold it in place. The lid is weighted so it rolls over and falls away.
3. As the G4 floats away from the lid, it moves out of range of the magnet. Once away from the magnet its sea switch becomes armed.
4. The sea switch activates. The EPIRB then floats on the surface with its strobe light flashing.

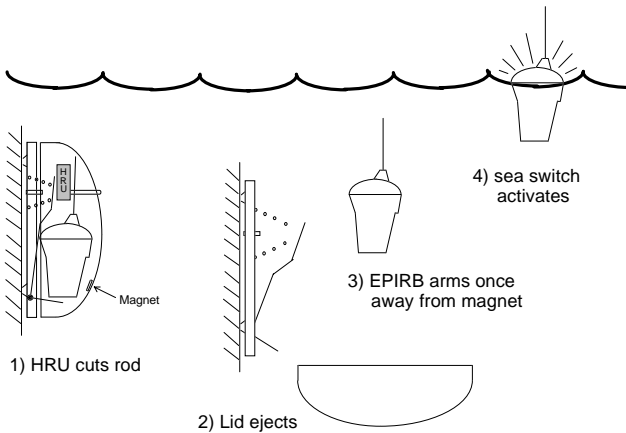

If you need to activate your G4 manually, it can be freed from the enclosure after pulling out the R-shaped retaining pin and removing the lid.

### 4.3 Manual G4 in enclosure

Customers who need to mount their G4 in an exposed position can select the protective enclosure without an HRU fitted (G4c). This means that the G4 will **not** float free if your vessel sinks. This is known as a category 2 EPIRB. You can tell which enclosure you have by reading the category from the front of the enclosure:

<b>G4a</b>	Category 1	HRU fitted	Automatic float-free
<b>G4c</b>	Category 2	No HRU fitted	Will not float free

# 5 CONTROLS

## 5.1 ON button

This is hidden behind a sliding door, which protects it from accidental activation. The sliding door has a tamper seal to show if the G4 has been activated.

The G4 can be activated manually by sliding the door to the left (breaking the seal) and then momentarily pressing the ON button.

When activated the G4 will start to flash immediately. It will not make any distress transmissions for 3 minutes. This gives you a chance to turn it off if you activated it accidentally. During this 3 minutes the red lamp illuminates continuously. When the red lamp starts to flash, the 3 minutes delay has passed and distress transmissions have started. Normally the green GPS lamp will start flashing within the first 5 minutes.

## 5.2 READY button

This button de-activates the G4 and also tests the G4.



### Ready

Pressing and releasing this button quickly will de-activate the G4 and return it to its “ready” state. When the button is released the strobe and the red & green lamps will stop flashing.

### Self-test

Pressing and holding the ready button (for about 10 seconds) will allow the built-in self-test to run. When the button is held down the red lamp will come on for 4 seconds, then go off. During this time both the 121.5MHz homer and the 406MHz satellite transmitter make “safe” transmissions. If both of these test transmissions arrive at the antenna with sufficient power then the strobe light will flash 3 times to tell you that all is well. If the red lamp does not come on, or the strobe light does not flash within 10 seconds, then there is a fault; the G4 should be taken to a service agent.

## 5.3 Sea switch

It is important to realise that the only time the G4 is completely off is when it is fitted in its mounting bracket or enclosure. As soon as you take it out, a magnetic switch activates and puts the G4 into its “ready” state. It will not drain the battery in this state, but it will turn on automatically if the sea switch contacts are bridged by water. The sea contacts are the two exposed screw heads beside the rear switches.

Although you can control the G4 manually with the READY and ON switches, the sea switch overrides any manual settings. For the manual switches to operate properly the G4 must first be dry so that the sea switch is de-activated.

To ensure the sea switch operates properly in rough seas, it has a built-in time delay. It has to be wet for at least 2 seconds before it will activate and it has to be dry for at least 8 seconds before it will de-activate.

## **5.4 Lamps**

### **5.4.1 Strobe**

The strobe is the visual means of locating the EPIRB. When activated, the strobe flashes 23 times per minute, with a pause during the time when the EPIRB is transmitting.

The strobe is also used to indicate the result of a self test (see section 11.1).

### **5.4.2 Red lamp**

The red lamp is used to indicate transmissions by the EPIRB. When activated, it flashes alternately with the strobe to indicate a good transmission on 121.5MHz. Every 50 seconds it illuminates for 2 seconds to indicate a good transmission on 406MHz.

When the EPIRB is first activated the red lamp is illuminated continuously until the EPIRB begins to transmit, when it begins to flash.

The red lamp is also used to indicate the result of a self test (see section 11.1).

### **5.4.3 Green lamp**

The green lamp flashes to indicate that a valid position has been obtained by the GPS receiver. Every 50 seconds it illuminates for 2 seconds to indicate that the position is being transmitted on 406MHz.

Every 20 minutes the GPS receiver updates its position information. If a fix is not obtained, the green lamp stops flashing, and illuminates only every 50 seconds (when the previous position information is transmitted).

The green lamp is not used during self test.

# 6 OPERATING PROCEDURE

An EPIRB is a piece of life saving equipment. Its sole purpose is to call for help. It must only be used in situations of grave and imminent danger.

Misuse can involve a severe penalty.

## 6.1 Sinking

If you have a category 1 “float-free” enclosure (see marking on enclosure label), then if your vessel sinks, the G4 will automatically release itself from its enclosure before it reaches a depth of 4 metres. The G4 will float to the surface and start to operate because its sea switch is activated.

If possible, the G4 should be recovered and tied (using its lanyard) to one of the liferafts. An EPIRB is meant to mark survivors, not the accident scene. For best operation leave the G4 floating in the sea near the liferaft.

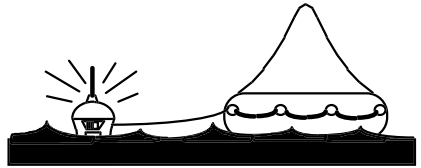

## 6.2 Abandon ship

If the vessel is sinking and there is time to fetch the EPIRB then this should always be done. Release the G4 from its mounting bracket as described in section 6.3 or 6.4 and carry it to one of the liferafts. Once the liferaft is in the water, uncoil the lanyard and tie it to the liferaft, then throw the G4 overboard so that it floats next to the liferaft. The G4 will operate because its sea switch will activate.

## 6.3 Releasing G4 from a wall bracket

If you have an G4 fitted into a wall bracket then follow the instructions below to release it from the bracket:

- 1 Squeeze top until it springs up

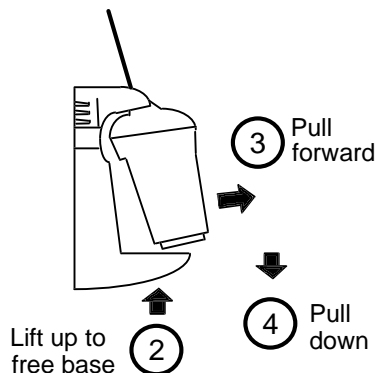
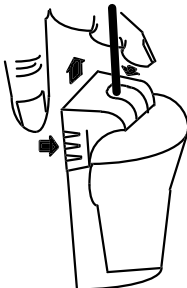

## 6.4 Releasing G4 from an enclosure

If your G4 is fitted inside a full enclosure then follow the instructions below to release it manually from its enclosure:

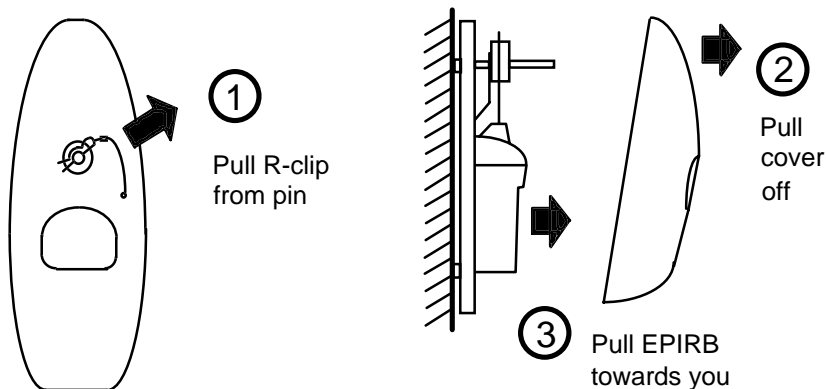

Do not let EPIRB fall out

## 6.5 Manual activation

If the vessel is not sinking, but there is imminent danger, then remove the G4 from its bracket and activate it manually as shown below. Note that once activated it will flash immediately, but it will not transmit a distress call for 3 minutes. This gives you a chance to turn it off if you activated it in error.

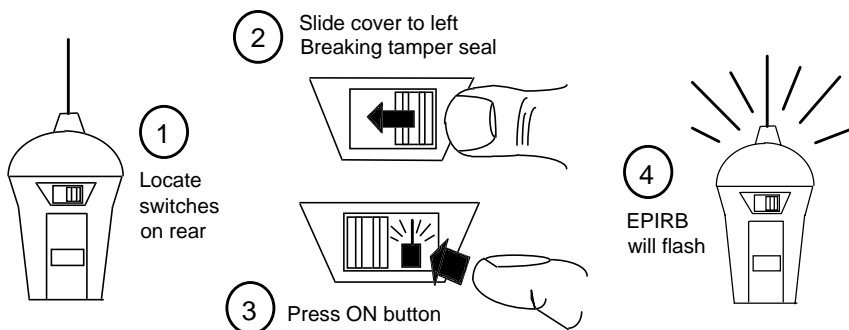

Once activated the G4 **must** have its antenna near upright and it must have a clear view of the sky for proper operation. Lying it on its side or placing it next to a metal wall will impair its range and may fail to alert the rescue services. Avoid handling the antenna, as this will also impair performance.

## 6.6 Deactivation

If the G4 was activated by mistake or if the emergency ends then the G4 can be reset back to its “ready” state as follows:

- **Remove EPIRB from any water and dry its sea switch contacts.**

Wait 8 seconds for sea switch to turn off.

If EPIRB is still flashing then it must have been turned on manually:

- **Slide the switch cover fully to the right.**
- **Press and release READY button.**

If EPIRB is still flashing then it has a fault.

Refer to section 7 on False Alarms.

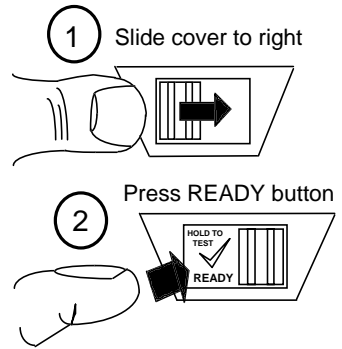

## 6.7 Battery condition

If your G4 has been activated for a cumulative period in excess of 2 hours then its battery will need replacing. This is necessary to ensure that the next time it gets used it will operate for the full 48 hours required by government regulations. See section 11.3 for battery replacement instructions.

## 6.8 Re-fitting G4

### 6.8.1 Refitting into wall bracket

The G4 is now in its “ready” state, but its sea switch is still armed and will activate if it gets wet. To de-activate the G4 fully it must be returned to its mounting bracket, where a magnet hidden in the bracket will make the G4 safe.

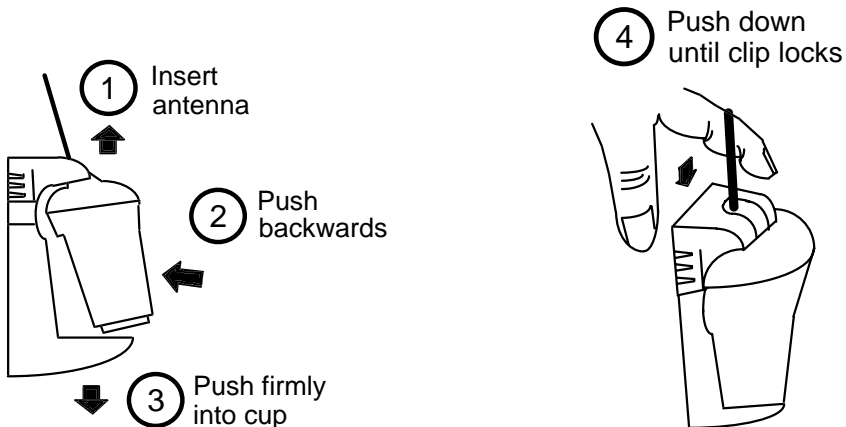

## 6.8.2 Re-fitting into enclosure

- Offer G4 into backplate with switches facing outwards.
- Engage base of G4 into D shaped metal prongs.
- Antenna rests either to left or right of release pin.
- Check G4 is fully engaged in metal prongs and resting on foam pad.
- Refit cover by first locating release pin through hole in cover.
- Locate cover onto backplate, then snap down over locating lug.
- Refit R-clip through hole in end of release pin.

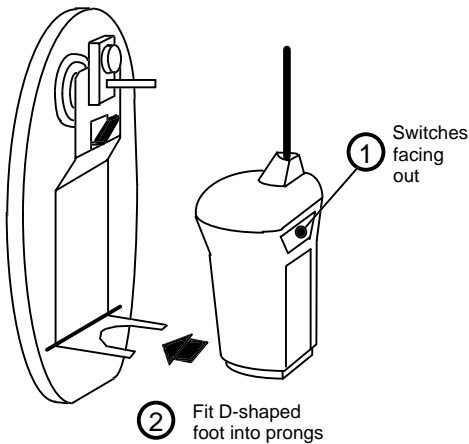

### CAUTION

Failure to fit EPIRB correctly may impair its ability to float free in an emergency

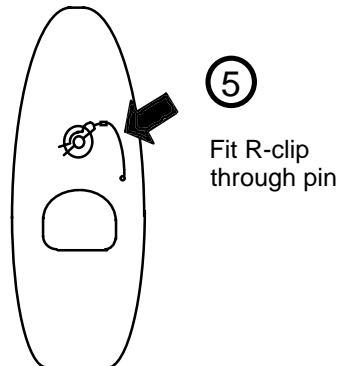
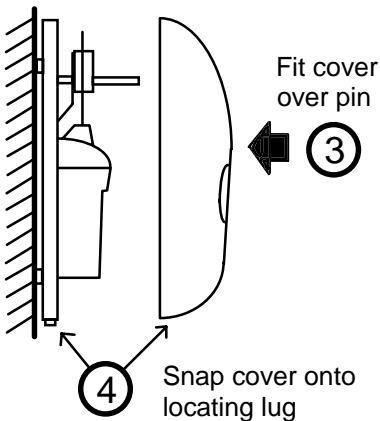



# 7 FALSE ALARMS

False alarms are a serious problem for the rescue services. About 90% of EPIRB initiated distress alerts turn out to be false alarms. If your EPIRB should cause a false alarm, follow the instructions below.

## 7.1 Stand down rescue services

It is most important that you contact the nearest search and rescue authorities and tell them it was a false alarm, so that they can stand down any rescue services. Use any means at your disposal to make contact. Often this can be by VHF radio to the local coastguard or mobile phone if you are within coastal range, but MF/HF DSC and Inmarsat A, B, C,M may also be used. Useful contacts are:

Country	Region	Telephone	What to report
USA	Atlantic / Gulf of Mexico	(212) 668 7055	EPIRB Unique ID (UIN)
	Pacific	(510) 437 3700	Date, time & duration
	From any location	(800) 323 7233	Cause of activation
UK	From any location	01326 317 575	Location when activated

## 7.2 De-activate the EPIRB

If the G4 was activated by mistake, then de-activation is simple:

- Remove the G4 from any water and dry its sea switch contacts.
- Wait about 8 seconds for the sea switch to de-activate.
- If the G4 is still flashing then it must have been turned on manually...
- Slide the switch cover fully to the right.
- Press **and release** the READY button.
- The G4 should now stop flashing.
- Refit the G4 correctly into its mounting bracket or enclosure.

Modern EPIRBs have sea switches and it is not uncommon for the sea switch to activate in rough seas or heavy rain simply because the EPIRB has been badly fitted in its mounting bracket. The G4 bracket has a hidden magnet to hold the G4 in an off state. If the G4 is wrongly fitted the magnet does not do its job and heavy seas may activate the sea switch. The simple cure is to ensure the G4 is correctly fitted as shown in sections 6.8 or 6.8.2.

### **7.3 Dealing with a transmitting G4**

In the unlikely event that your G4 develops a fault and will not turn off, then prevent its radio signal from reaching the satellite using one of the following methods:

- Remove the antenna. Wrap the G4 in metal foil and take it below decks.

or

- Remove the antenna and place the G4 in a metal container or locker.

Leave it in this condition for 3 days until its battery is dead. See section 11.4 for instructions on returning the G4 for servicing. See also section 12.

# 8 WALL BRACKET INSTALLATION

## 8.1 Siting

The wall bracket should ideally be sited in plain view near an emergency exit. When choosing a suitable mounting position you should also consider:

- Ease of access in an emergency.
- Mount at least 1 metre (3') from any compass equipment.
- Allow at least 25mm (1") above the bracket for it to spring open.
- Allow 18cm (7") for the antenna. Heavy bending of the antenna is bad.

## 8.2 Mounting procedure

The wall bracket is supplied with a set of stainless steel fixings 25mm (1") in length. The bracket mounts against a flat surface using 4 fixing points. Offer the bracket into the chosen position and mark through the mounting slots. If you are using the nuts and bolts supplied, drill 6mm (1/4") holes in the centre of each mark. You will need a 4mm Allen key to tighten the bolts. If the rear of the mounting surface is inaccessible then use the self-tapping screws supplied and drill 3mm (1/8") holes. Always fit washers under the heads of the screws to avoid damage to the plastic.

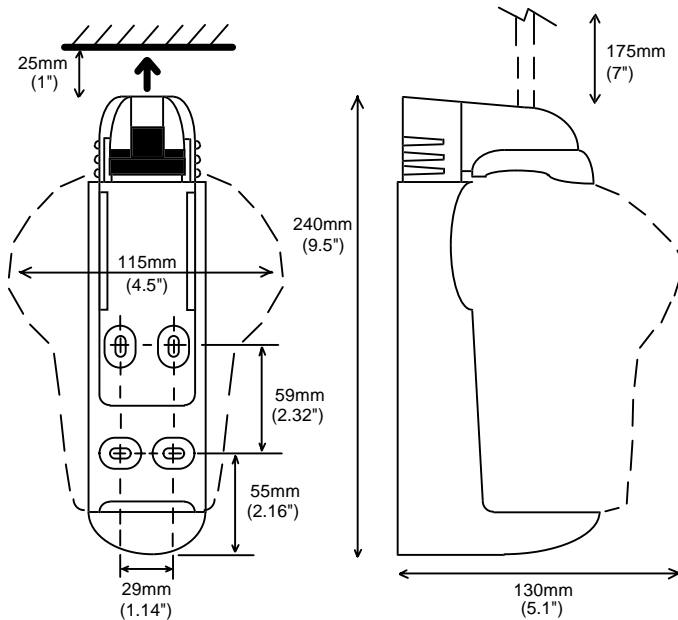

### 8.3 Mounting instruction plate

The G4 is supplied with an instruction plate. This is a rigid plate with basic visual instructions for how to operate the G4 in an emergency. The plate varies slightly depending on whether you have a wall bracket or a full enclosure. The wall bracket version is illustrated below.

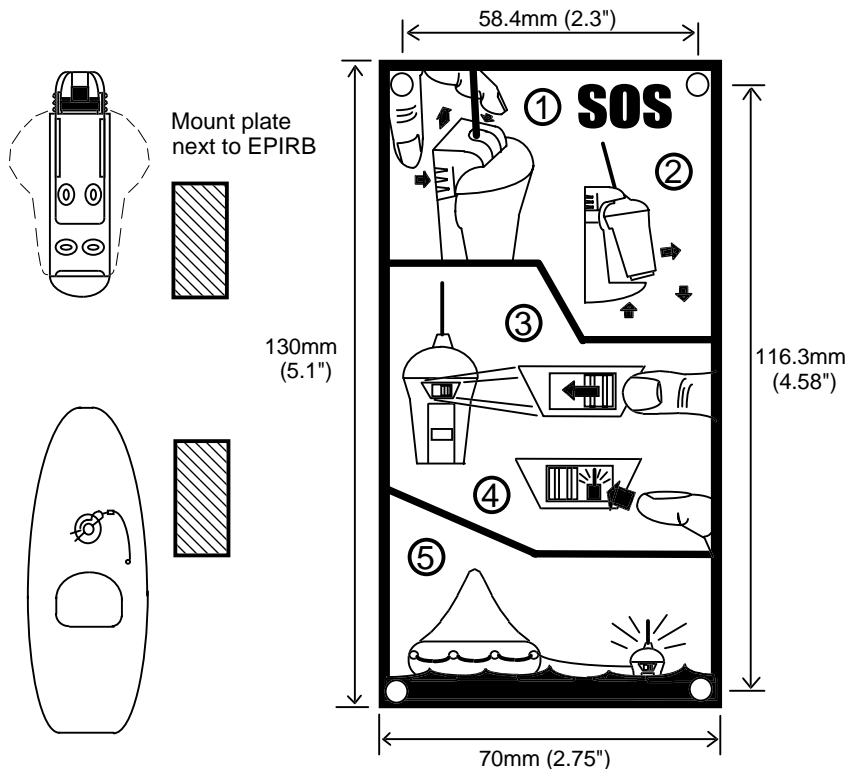

The instruction plate should be mounted next to the EPIRB so that it is easily visible in an emergency. Use the four self-tapping screws supplied to mount the plate. Mounting dimensions are shown in the diagram above, or you can use the plate itself at a drilling guide for the screws.

During vessel maintenance, ensure the plate does not get painted over or cleaned down with strong degreasing solvents.

# 9 ENCLOSURE INSTALLATION

## 9.1 Siting

The enclosure should be mounted upright against a vertical bulkhead. Alternately, it may be mounted horizontally on a flat surface, such as a cabin roof. No other orientations are recommended

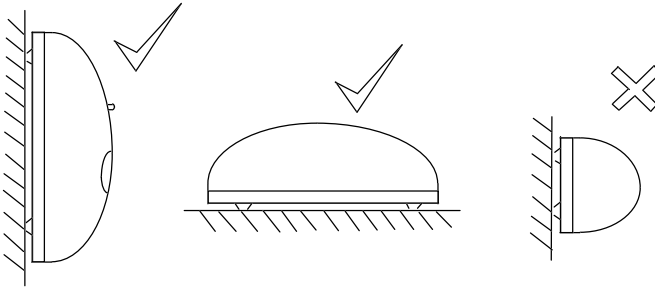

If you have a float-free G4 it is critical that you choose a position where the released EPIRB will **not get trapped by overhangs, rigging, antennas** etc, should the vessel ever sink. An expanse of flat surface is required to allow the enclosure lid to eject. Use the list below to choose a suitable mounting position:

- Mount on the outside of the vessel's structure.
- Mount close to the vessel's navigation position.
- Consider ease of access in an emergency.

### AVOID

- Positions with insufficient space for lid ejection and maintenance.
- Positions within 1m (3') of any compass equipment.
- Mounting within 2m (6') of any Radar antenna.
- Direct impact from waves
- Siting where damage is likely.
- Exhaust fumes, chemical and oil sources.

## 9.2 Mounting procedure

The enclosure mounts against a flat surface using 4 fixing points. See illustration for mounting dimensions, or use the backplate of the enclosure as a marking guide. To do this, pull out the R-shaped clip and remove the enclosure lid. Note how the G4 fits then remove it to somewhere dry (its sea switch is now armed).

Offer the back plate into the chosen position and mark through the mounting holes. The enclosure is supplied with a set of 25mm (1") stainless steel fixings. If you are using the nuts and bolts, drill 6mm (1/4") holes where you have marked. You will need

a 4mm Allen key to tighten the bolts. If the rear of the mounting surface is inaccessible, use the self-tapping screws supplied. Always fit washers under heads of the screws to avoid damaging the plastic.

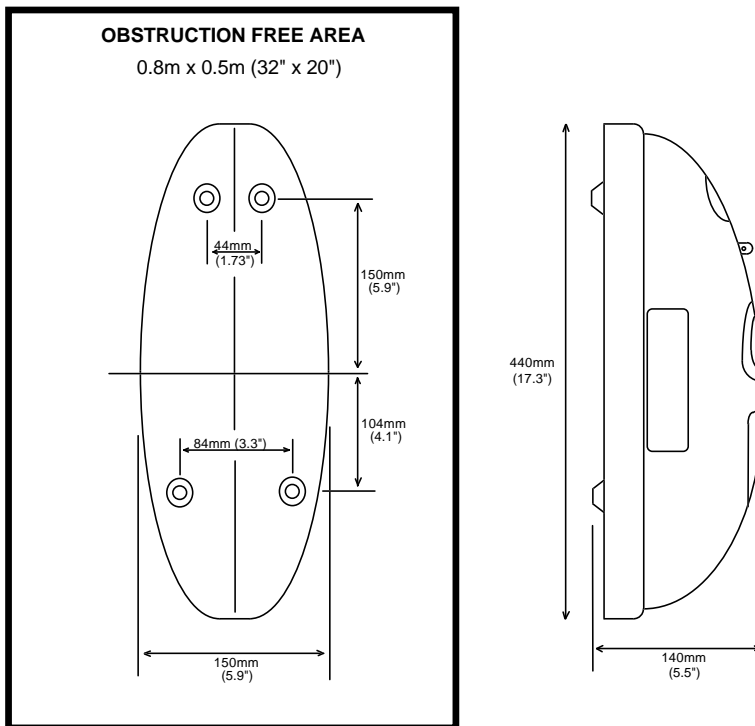

### 9.3 Mounting instruction plate

The G4 is supplied with a rigid plate giving visual instructions on how to operate the G4 in an emergency. Mount this next to your EPIRB as explained in section 8.3.

### 9.4 Marking HRU expiry

If you are installing a float-free G4 you **must** now mark the HRU expiry date. The HRU has a 2 year in-service life which starts as soon as it gets exposure to a marine environment. Hence the 2 years starts at installation and it is left to the customer to mark this date during installation. A date 2 years into the future should be marked on the HRU body and copied onto the label on the side of the enclosure. The HRU is marked by cutting out the corresponding dates on its label. The enclosure should be marked using the alpha-numeric stickers provided, then covering them with the clear sticky label provided (but see 9.5 first). The preferred date format is month and year, for example : JUN 2001.

## 9.5 Marking vessel name

In most countries it is usual to have your EPIRB programmed by your supplier with the vessel's existing "callsign" (see registration section below). Your supplier will then mark all the EPIRB labels accordingly. However, if your EPIRB was purchased in the USA, Canada or UK then your EPIRB will have all the necessary markings except for vessel name. In these countries it is left to the customer to mark the vessel name during installation.

The name must be marked on the rear of the G4 itself and also on the enclosure, if you have one. Use the alpha-numeric stickers provided to mark the vessel name (or its abbreviation) on the top line of the G4's rear label and again on the enclosure label. Protect the markings with a section of the clear sticky label provided.

You must register your EPIRB with the appropriate authorities.

**Failure to register may slow the rescue and lead to loss of life.**

**In the USA failure to register leads to monetary forfeit.**

# 10 REGISTRATION

## 10.1 Overview

Every EPIRB is pre-programmed with a unique identity before it reaches the customer. This is done by the manufacturer or in some cases the distributor. The identity includes a 3 digit country code. This is the country that takes responsibility for storing that particular EPIRB's registration details. In most cases this is the country to which the vessel is flagged. The country programmed into your G4 can be found from its rear identity label. You **must** register with this country.

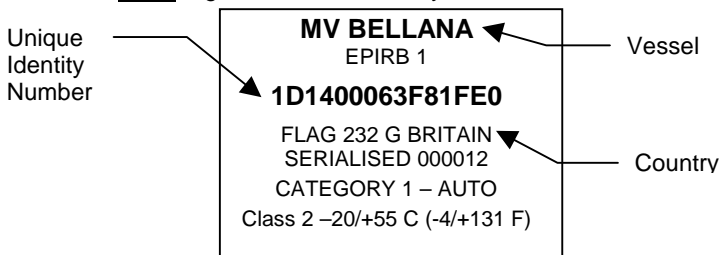

When you activate your EPIRB in an emergency, the nearest maritime search and rescue coordination centre (MRCC) will receive the message and decode the country code (eg 232). They will then access the registration database for that country and expect to find details of your vessel, its radio equipment and who to contact. If they fail to find this information, this may slow down any rescue.

## 10.2 How to register

Three registration forms are provided, two are for future use and one must be completed now. The forms are all pre-printed with your EPIRB's identity, all you have to do is complete details of your vessel and provide some contact numbers. Wherever possible the forms are also pre-printed with the correct mailing address and a faxback number. If your form does not have a mailing address, contact your supplier. When you have completed the form, you can choose to fax it or mail it.

It is usual to receive confirmation when you register. In the USA you will also receive a "Decal" sticker which you must fit to the G4 itself. The Decal is proof of registration. Not having a Decal is an offence. Useful registration contacts are:

USA Sarsat Beacon Registration  
E/SP3, RM3320, FB-4  
NOAA, 5200 Auth Road  
Suitland MD 20746-4304  
Tel 888 212 7283 Fax 301 568 8649

UK EPIRB Registry  
HM Coastguard (Southern)  
Pendennis Point, Castle Drive  
Falmouth TR11 4WZ  
Tel 01326 211569 Fax 01326 319264

## 10.3 Warranty form

Please complete the warranty form supplied and fax or mail it to McMurdo. Failure to do this may delay any future warranty claim.



## **10.4 Radio licence**

An EPIRB is a radio transmitter and must therefore be added to your radio licence. If you have been allocated a radio callsign, then you already have a radio licence for your VHF or MF radio set. You should update your licence to include your EPIRB. For further details see your licence or use these contact numbers...

**USA** FCC Tel : 888 225 5322 Website : [www.fcc.gov/Forms/Form506/506.pdf](http://www.fcc.gov/Forms/Form506/506.pdf)

**UK** Wray Castle, PO Box 5, Ambleside, Cumbria LA22 0BF. Tel : 01539 434662

## **10.5 Sale or transfer**

EPIRBs registered in the USA, Canada, UK and Australia do not need to be re-programmed when transferred to a new vessel. Simply complete another registration form to inform the authorities of the transfer. Use one of the spare forms provided or contact McMurdo for a blank form. (See warranty section for address).

For most other countries, the EPIRB must be re-programmed with either the new vessel's Maritime Mobile Station Identity (MMSI) or its radio callsign, whichever is required by the country controlling the new vessel.

Since the EPIRB identity contains a country code, it follows that changing the flag state of the vessel also means the EPIRB must be re-programmed.

Programming can be carried out at McMurdo or any of our designated agents. For details of your nearest agent, either contact McMurdo using the details in the warranty section, or visit the McMurdo web site at [www.mcmurdo.co.uk](http://www.mcmurdo.co.uk).

# 11 MAINTENANCE

## 11.1 Monthly self-test & inspection

As an important item of safety equipment, your G4 should be checked regularly. The G4 has a built-in test capability that can be used as a confidence check. This self-test confirms that the battery is healthy, that the GPS receiver and both of the distress transmitters are functional and that the strobe light is operational. The self-test should be performed **monthly**. It should be performed during the first 5 minutes of the hour, to minimise disturbance on the emergency channel.

If your G4 is in an enclosure it can be tested through the test window without having to remove the G4 from the housing. If you have a bracket mounted G4 it will have to be removed from the bracket as described in section 6.3. The procedure for self-testing is as follows:

- On rear of G4 press and **hold** the READY button.
- The red lamp will come on for 4 seconds to confirm test in progress.
- When the red lamp goes out, the strobe lamp **must flash** 3 times (at least).
- If the strobe does not flash, or the red lamp illuminate, repeat the test then see section 11.4.

During these monthly checks you should take the opportunity to visually inspect the G4 and its mountings for deterioration or damage.

On the G4 itself check the following:

- Inspect the G4 for any obvious damage.
- Check there is no sign of water inside the unit.
- Check that the lanyard is not tied to the vessel structure.
- Check the battery is within its expiry date.

If you have a wall bracket:

- Confirm the bracket top clip springs up when squeezed.
- Check the G4 is correctly fitted and secure in its bracket.

If you have an enclosure:

Check the HRU is within its expiry date (category 1 only).

Confirm the cover can be manually removed with ease.

Ensure the G4 base is correctly fitted into the D-shaped prongs.

If the G4 or its mounting needs cleaning then this should be done using warm soapy water and a damp (not wet) cloth. Do not use strong detergents or solvents.

**Do not paint the G4 or its mounting**

**Do not clean with detergents or solvents**

During vessel cleansing or painting remove the G4 and its mounting.

## 11.2 HRU replacement

If you have an G4 in an enclosure marked Category 1 then it contains a Hydrostatic Release Unit (HRU). This has a 2 year replacement interval. The expiry date, which is marked on the HRU and on the enclosure side label should be checked regularly.

When the HRU expires you can obtain a replacement at a local chandler, or direct from McMurdo at the address shown on the warranty page. McMurdo will supply an HRU kit (Part No. 82-210B) complete with breakable plastic rod, date labels and instruction sheet. At a chandler you should ask for a Pains Wessex "Breakthrough HRU with an EPIRB kit". The HRU replacement procedure is as follows:

- On the enclosure, remove the R-clip and pull the cover slowly off.
- Remove the G4 and stow it in a dry place. **It will activate if wet.**
- Hold down the metal lever arm to take up the force of the spring.
- Push the HRU back then upwards out of the slot in the lever arm.
- When the rear clip disengages slowly release the lever arm.
- The HRU with its breakable rod can now be lifted free and replaced.
- Using pliers, remove the rear E-clip and slide off the old HRU.
- Fit the new HRU over the new rod, with its label facing outward.
- Refit the washer and the rear E-clip. Ensure rod moves freely.
- Mark the HRU with an expiry date 2 years into the future.
- Slide the HRU into the slot in the lever arm and push lever arm down.
- Engage rear washer into backplate by pushing back and sliding down.
- Look under the spring and check that the washer is fully engaged.
- Slide G4 into D-shaped foot on lever arm, switches outermost.
- Refit cover by engaging hole over rod and then snapping into place.
- Refit R-clip through top of rod.
- On side of cover, remove old HRU expiry date and mark new date.

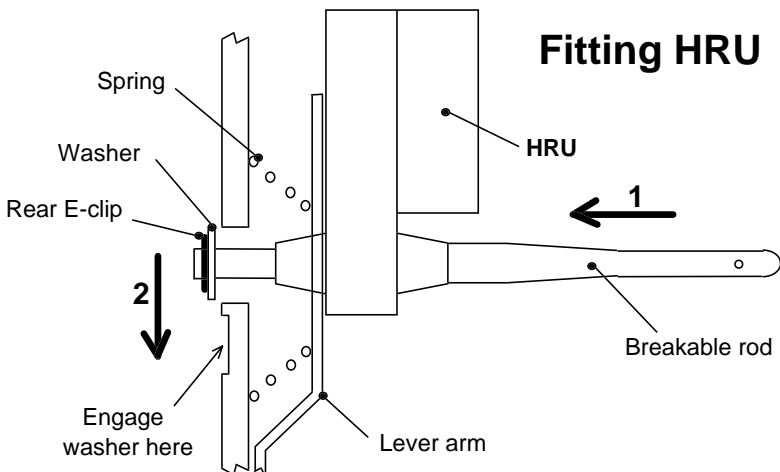

### 11.3 Battery replacement

The G4 uses a 9V Lithium battery pack, McMurdo type 82-570. Typically this will have to be replaced every 5 years. The exact battery expiry date is marked on the rear of the G4 lens dome and if you have a full enclosure it is also marked on the outside of the enclosure. The battery expiry date should be checked regularly. You will need to replace the battery when:

- The expiry date has been reached **or**
- The G4 has been used in an emergency situation **or**
- A false activation exceeds 2 hours of use.

The battery is a one shot device. It is not rechargeable or user replaceable. Battery replacement **must** be carried out by a McMurdo approved service agent. Lithium batteries have special disposal requirements. Never incinerate a Lithium battery. Never dispose of one at sea. Your service agent will deal with battery disposal.

### 11.4 Servicing

All servicing must be carried out by a McMurdo approved service agent. Always call your nearest agent and talk to their service department before returning suspect equipment. You can find your nearest service agent from:

- The McMurdo web site: <http://www.mcmurdo.co.uk>
- Contacting McMurdo direct (see warranty page).
- Contacting a McMurdo distributor

### 11.5 Transportation

The G4 has no special transportation requirements. Its Lithium battery has been tested under the “Transportation of Dangerous Goods” regulations and has been declared as non-hazardous for transportation purposes.

### 11.6 GMDSS inspections

If your vessel is subject to GMDSS regulations then you can expect to get regular visits from ship surveyors enforcing national legislation. They will check the expiry dates and activate the EPIRB to prove that it really works and they will read the identity message stored inside the EPIRB to check that you have registered it properly. Leisure vessels are not subject to these inspections. However, in some countries passenger and fishing vessels are covered by the legislation.

## 12 FULLY DISABLING A G4

In the unlikely event that your G4 refuses to turn off then it may have a fault. Procedures for dealing with a faulty G4 are covered in section 7 on false alarms; in simple terms you should do the following:

- De-activate the EPIRB as described in section 7.2
- Suppress its signal by removing the antenna and wrapping the G4 in metal foil, as described in section 7.3
- Leave for 3 days until the battery is used up.

**We do not recommend any other course of action.** However, if it is absolutely necessary to fully disable an G4 (by unplugging its battery), proceed as follows. This is a dangerous task and should only be performed by a qualified technician.

**WARNING:** Risk of electric shock. **Proceed at your own risk, no liability accepted**

- Take the G4 below decks into the dry.
- Locate a flat bladed screwdriver with a long reach.
- Unscrew and retain the front 4 sealing screws.
- Pull the lanyard out and remove the 2 hidden rear screws.
- Do **not** as yet remove the sea contact screws.
- Lift the lens dome off. Remove and retain the grey gasket.
- **Avoid touching the circuit board and the glass strobe tube.**
- Hold the hexagon shaped pillars and remove the sea screws.
- Use a cross-headed screwdriver to remove the front screw.
- Grip the white plastic coil former and lift the circuit board up 3cm (1").
- Using fingers, unplug the white 4-way battery connector.
- The flashing will now cease.
- Collect all the parts and return them to your nearest service agent.



270V DC

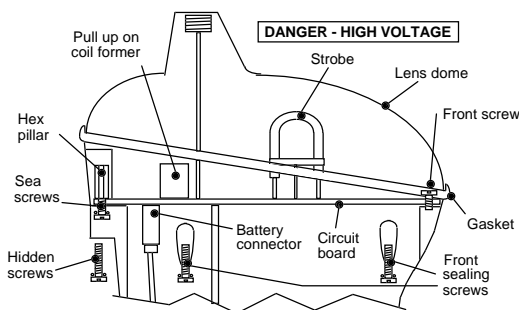

# 13 TECHNICAL SPECIFICATION

<b>406MHz Transmitter</b>	Operating frequency	406.028 MHz $\pm$ 1kHz
	Power output	5W typical
	Modulation	Phase (16K0GID)
<b>121.5MHz Homer</b>	Operating frequency	121.5 MHz +/- 3.5kHz
	Power output	50mW radiated typical
	Modulation	Swept tone AM (3K20A3X)
<b>GPS Receiver</b>	Centre frequency	1.57542GHz
	Sensitivity	-175dBW minimum
	Satellites tracked	12 max
<b>Strobe light</b>	Type	Xenon discharge tube
	Light output	0.75 Candela minimum
	Flash rate	23 flashes per minute
<b>Battery</b>	Type	Lithium manganese dioxide
	Operating life	48 hours minimum
	Shelf life	5 years typical in service
<b>Environment</b>	Operating temperature	-20°C to +55°C (class 2)
	Storage temperature	-30°C to +70°C
	Automatic release depth	4 metres max. (13 feet)
<b>Physical</b>	Weight	770 grammes (1.7 lb)
	Height of body	21 cm (8.2 inches)
	Length of antenna	18 cm (7 inches)
<b>Approvals</b>	Satellite system	Cospas-Sarsat T.001/T.007
	Europe	ETS-300-066 Marine Equipment Directive
	USA	USCG / FCC approved FCC ID : KLS-82-501
	Worldwide	IEC1097-2
	Meets IMO regulations	A662(16) A694(17) A810(19) A814(19)

This device complies with the GMDSS provisions of part 80 of the FCC rules.

The GPS module complies with the relevant sections of IEC1108-1:1996.

## **McMurdo Limited Product Warranty**

Subject to the provisions set out below McMurdo Limited warrants that this product will be free of defects in materials and workmanship for a period of 12 months from the date of purchase.

McMurdo Limited will not be liable to the buyer under the above warranty:-

- for any defect arising from fair wear and tear, wilful damage, negligence, abnormal working conditions, failure to follow McMurdo Limited's instructions (whether oral or in writing) including a failure to install properly and/or to use batteries recommended and/or supplied by McMurdo Limited, misuse or alterations or repair of the product by persons other than McMurdo Limited or an Approved Service Agent;
- for parts, materials or equipment not manufactured by McMurdo Limited in respect of which the buyer shall only be entitled to the benefit of any warranty or guarantee given by the manufacturer to McMurdo Limited;
- for the battery storage life which is specifically excluded from this warranty;
- if the total price for the product has not been paid.

McMurdo Limited does not make any other promises or warranties (express, implied or statutory) about the product except where the product is sold to a consumer in which case the statutory rights of a consumer are not to be affected.

In order to be valid, claims must be made under the above warranty in writing as soon as practicable after discovery of the defect or failure and within the warranty period referred to above. Proof of purchase will be required. The claim should be sent together with the product in question to the address set out below or to an Approved Service Agent.

Following a valid warranty claim McMurdo Limited shall be entitled to repair or replace the product (or part) in question free of charge, or at McMurdo Limited's sole discretion to refund to the buyer the price of the product (or a proportional part of the price). McMurdo Limited shall not be liable to a buyer who is not a consumer for any other loss or damage (whether indirect, special or consequential loss of profit or otherwise) costs, expenses or other claims for compensation which arise out of or in connection with this product. In the case of a consumer McMurdo Limited shall only be liable where other loss or damage is foreseeable.

Nothing shall limit McMurdo Limited's liability for death or personal injury caused by its negligence.

This warranty is to be interpreted under English law.

All enquiries relating to this warranty or Approved Service Agents should be sent to:

**McMurdo Limited**  
**Rodney Road**  
**Portsmouth**  
**Hampshire**  
**PO4 8SG**  
**United Kingdom**

**Telephone: Int + 44 (0) 23 9277 5044 Fax: Int + 44 (0) 23 9281 9087**  
**Web: www.mcmurdo.co.uk Email: sales@mcmurdo.co.uk**

Record Serial No. (visible through dome) : \_\_\_\_\_

## **McMurdo Ltd**

Rodney Road  
Fratton  
Portsmouth  
Hampshire  
United Kingdom  
PO4 8SG



A member of Chemring Group PLC

**82-569-001M Issue 1**