



# iVISION+

Wireless Video Intercom

## IVP-DU (Door Camera Unit) Installation Instructions



### ATTENTION:

Thank you for purchasing the iVISION+ wireless video intercom. Before installation and usage, please read this instruction manual thoroughly and keep this safe for future reference.

### IVP-DU features

- Adjustable Camera Angle
- Battery Operation Capability (for 1 year\*1)
- Auto Day(Color) / Night(IR) Vision
- Max 2 Units in a System
- Fluorescent Push Button
- AC/DC (10~24V) Adaptable
- Splash Proof for Rain and Outdoor Condition\*2

\*1 calculation based on operations for 10sec times 3 activations per a day  
 \*2 IPX4 Operating Temperature -20 to 50 degC (-4 F to 122 degF)

## 1. IMPORTANT NOTICE

constant moisturization  
**Operations under harsh environments** such as out of warranted temperature, rapid temperature change, high humidity, constant moisturization may cause the unit to malfunction.

**Electronic device** such as TVs, Radios, PCs, Microwave ovens or any other device with an electric motor may cause the unit to malfunction.

**Impact or shocks** can cause severe damage to the unit. Please handle the unit with care and operate without exerting strong forces.

**Transmission range** of communication between units may decrease under the following conditions.

- Any unit is installed on a metal surface.
- Presence of reinforced concrete, steel doors or other metal construction materials between units.
- Places near strong radio sources such as broadcast stations or substations.

**Location of Installation** is critical to optimize image quality captured by the unit. Images will be impaired if the ambient backlight is very strong.

Please study the installation environment according to this installation instruction.  
- The video image is displayed in color during daytime or in well-lit area, but it is displayed in black and white at night or in a dark area.

**Old and new batteries** may not be mixed. **Do not use lithium** batteries for IVP-DU. Leakage or possible explosion can occur.

- When Door Camera Unit Low Battery Indicator blinks on HU1, please replace batteries.

## 3. CHOOSING LOCATION

### 3-1 Places to Avoid

The performance of the system may be affected when mounting the unit in the following environments.

- Places that are constantly experiencing vibrations or shocks.
- Near a source of hydrosulfuric fumes, phosphorus fumes, ammonia, sulphur, carbon dust and any acidic or noxious materials.
- An enclosed space that may cause sounds to echo
- Where rain or water may directly hit the unit.

Please also note that the video image may be seriously impaired where the camera faces directly into the sun, and also in the following situations.

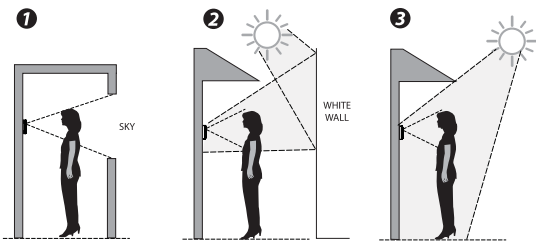

- 1 Location where the background is primarily occupied by the sky, such as in the upper floor of an apartment building.
- 2 Location which has an adjacent white wall that will directly reflect sunlight.
- 3 Location that receives direct bright sunlight.

## 4. INSTALLATION

### 4-1 Unit Preparation

Remove the main unit from the mounting base



## 2. PARTS IDENTIFICATION

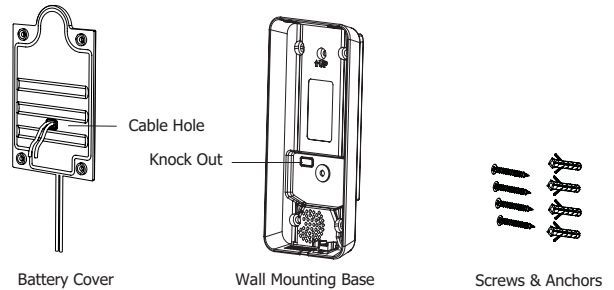
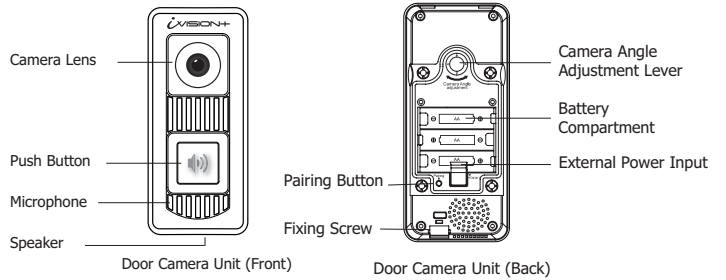

### 3-2 Position and Field of View

IVP-DU (Door Camera Unit) should be mounted at a position where visitors or potential trespassers can be captured in the camera's field of view. In a typical setting, IVP-DU is positioned at height between 3.6 -5 feet off the ground.

Camera Angle Adjustment Lever can shift the camera's field of view max +/- 15 degrees to any combination of vertical and horizontal directions.

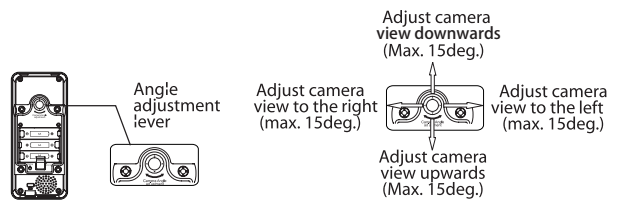

### 4-2 Fixing the Base

Fix the mounting base on the wall at the height and location selected.

NOTE: When using an external power source, make a knockout hole on the Mounting Base before fixing to a wall. Place the Mounting Base on a horizontal surface front side down. Point a driver in the center of the knock out and apply gentle impacts to break a hole through.

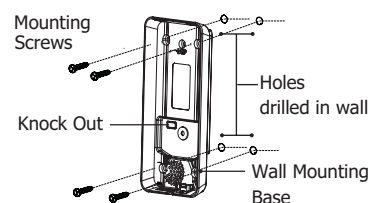

**CAUTION**

**Old and new batteries** may not be mixed. **Do not use lithium** batteries for IVP-DU. Leakage or possible explosion can occur.

Insert 3 x AA alkaline batteries.  
Please ensure to match the correct +/- polarity as shown.

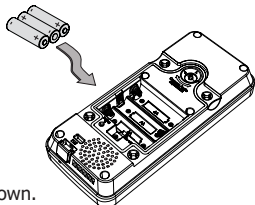

The Camera Door Unit may also be powered from an external power source. If available, connect the unit directly to the existing AC/DC 10-24V doorbell power supply or, alternatively, an AC/DC 10-24V third party's external power pack may be used.

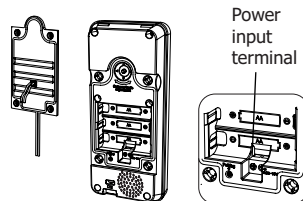

Pass the bell wire or the wire from a power pack through the mounting plate before fixing the plate to the wall. Connect the wire to the Power input terminal.

**WARNING**  
External power must not be used with batteries.

## 5. PAIRING WITH IVP-HU (Handheld Monitor Unit)

NOTE: One Handheld Monitor Unit (IVP-HU) must be configured to have a HOME ID\*1 prior to pairing up with other iVISION+ devices. For setting up a new HOME ID, refer to the Installation Instruction of IVP-HU. A Handheld Monitor Unit bundled with Door Camera Unit already has a HOME ID set up and paired up to each other. Proceed to OPERATION CHECK unless additional pairing is required.

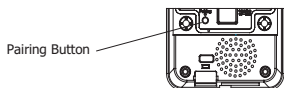

(1) Enabling Paring Mode of a Door Camera Unit (IVP-DU)  
Press a PUSH button on the front then push pairing button located at the bottom of battery compartment until the unit makes a beeping sound. The Door Camera Unit will clear its HOME ID assignment and starts looking for a New HOME ID. 5 short beeps will repeat until the unit is paired or power/batteries displacement.

(2) Assigning a HOME ID to a Door Camera Unit (IVP-DU)  
When a Handheld Monitor Unit in a paring mode, choose "SCAN" by pressing Left Function Key. Door Camera Unit will automatically be assigned to a new HOME ID and beeping will stop. Repeat the same procedure for an addition unit. The first paired IVP-DU will be assigned as DU1. The second paired IVP-DU will be assigned as DU2.

NOTE: While the Door Camera Unit is in a factory default setting, the unit has not been assigned to a HOME ID\*1. When powering the unit, 5 short beeps indicates its paring mode.

\*1 HOME ID is a unique identification number for your iVISION+ system.

## 8. SPECIFICATION

### 8-1 Dimensions

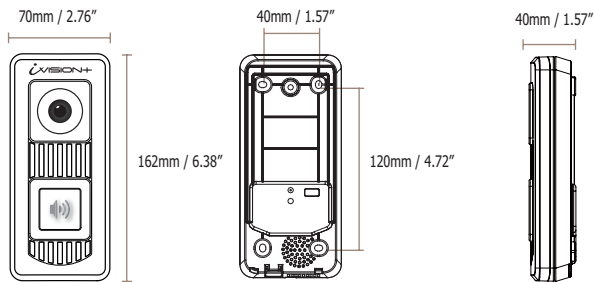

### 8-2 Specification Table

MODEL NAME: OPTEX iVISION+ (IVP-DU) Door Camera Unit

Operating Temperature	- 20 to 50 degC (-4 to 120 degF)
Operating Humidity	< 90% RH (no condensation)
Warranty	1 year
Dust/Water Protection	IPX4 Splash Proof (Water Drain Structure)
Radiowave Frequency	2.4 GHz
Camera/Lighting Unit	Color vision / IR lighting LED
Power	Battery (3 AA Alkaline) or AC/DC 10-24V 3W (max)
Battery Life Expectancy	12 month *

\* Based on 3 activations (approx. 10sec each) per day

## 9. WARRANTY

- This product is warranted under normal use for 1 year from the date of purchase. If the product proves to be defective, return it with a copy of your dated sales receipt for repairs or replacement without charge.
- The warranty is not applicable when below circumstances will be found:
  - Mechanical or electrical modification(s) are made to the product or it is otherwise altered manually.
  - The product is already been at place(s) other than the manufacturer.
  - It is determined that the product malfunction has resulted from improper use or from an accident.
  - No copy of the dated sales receipt has been submitted together with the product to be served.



### OPTEX CO., LTD. (JAPAN)

5-8-12 Ogoto Otsu  
Shiga 520-0101  
JAPAN  
TEL: +81-77-579-8670  
FAX: +81-77-579-8190  
URL: <http://www.optex.co.jp/e/>  
(ISO 9001 Certified)  
(ISO 14001 Certified)

### OPTEX INCORPORATED (USA)

13661 Benson Ave., Bldg. C  
Chino, CA 91710  
U.S.A.  
TEL: +1-909-993-5770  
Tech: (800)966-7839  
URL: <http://www.optexamerica.com/>



# iVISION+

Wireless Video Intercom

## IVP-HU (Handheld Monitor Unit) Installation Instructions



### ATTENTION:

Thank you for purchasing the iVISION+ wireless video intercom. Before installation and usage, please read this instruction manual thoroughly and keep this safe for future reference.

### IVP-HU features

- 2.4 inch TFT LCD Monitor
- Wall-mountable Cradle
- Max 4 Units in a System
- micro-USB port to PC connection
- Manual/Auto Talk Switching

## 1. IMPORTANT NOTICE

**Operations under harsh environments** such as out of warranted temperature, rapid temperature change, high humidity, constant moisturization may cause the unit to malfunction.

**Electronic device** such as TVs, Radios, PCs, Microwave ovens or any other device with an electric motor may cause the unit to malfunction.

**Impact or shocks** can cause severe damage to the unit. Please handle the unit with care and operate without exerting strong forces.

**Transmission range** of communication between units may decrease under the following conditions.

- Any unit is installed on a metal surface.
- Presence of reinforced concrete, steel doors or other metal construction materials between units.
- Places near strong radio sources such as broadcast stations or substations.

**Avoid using** the Handheld Monitor Unit in the following areas

- Close to a fire, thermal appliance or other source of extreme heat/cold.
- Within 10ft (3m) of a television, microwave oven, personal computer, wireless LAN equipment, wireless audio/visual equipment - the radio frequency waves emitted by these devices can affect operation.
- In direct sunlight.
- Where extreme fluctuations in temperature can occur - if moving the unit from a warm to cold environment, or vice versa, please allow 30 minutes before use.

### Privacy & portrait/image rights

- Please respect the privacy and image rights of others when using this equipment. By using this equipment the user assumes total responsibility in upholding these rights.
- Images stored must not be used for any purpose other than that for which the equipment is designed.
- Images should be deleted once no longer required.

## 2. PARTS IDENTIFICATION

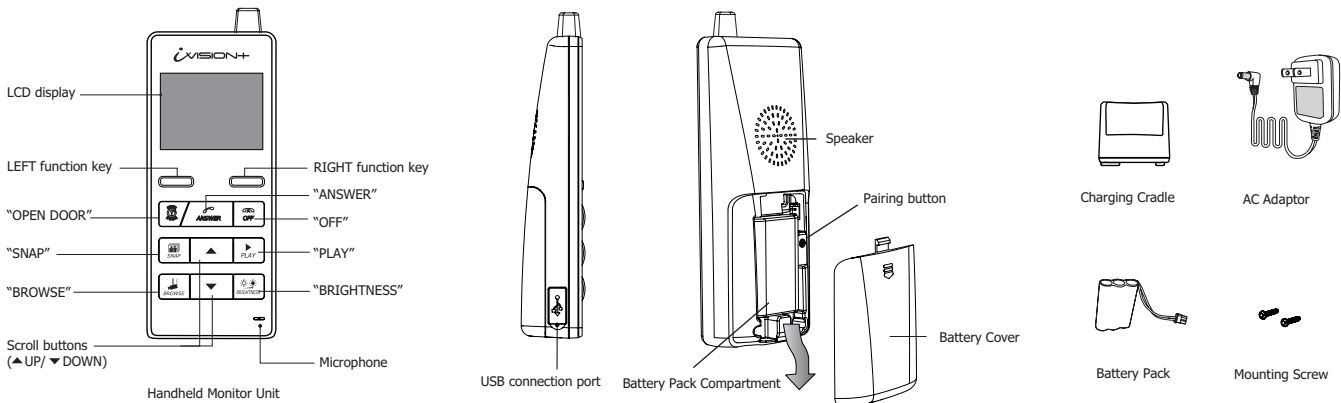

## 3. CHOOSING LOCATION

The performance of the iVISION+ system is dependant on the radio frequency environment and distances between devices. Following materials may decrease the maximum transmission distance and may cause the Handheld Monitor Unit inability to respond to incoming signals.

- Metal barricades such as metal doors and shutters.
- Walls with aluminium foil insulation.
- Concrete or galvanized metal walls.

The effective communication range is around 300ft (100m) in an open air condition (line of sight). This range will be significantly reduced by the number and thickness of walls through which the signal is required to pass. Please keep to a minimum number of walls wherever possible.

Handheld Monitor Units use 2.4GHz radio frequency. Any electrical appliance may become a potential cause for malfunction. Please avoid using the Handheld Monitor Unit near microwave oven or any electrical devices with similar radio frequency.

## 4. INSTALLATION

Handheld Monitor Unit must be set on Charging Cradle to retain its power while iVISION+ system is not in operation. The Charging Cradle can either be free-standing on a horizontal surface or be mounted on a wall as described below.

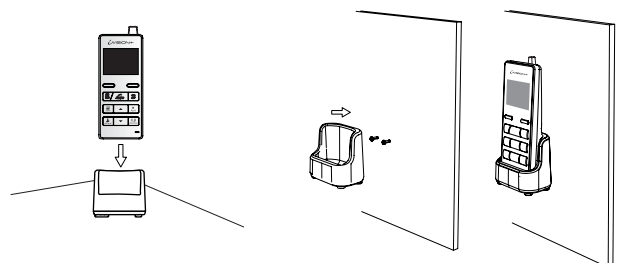

## 5. POWERING THE UNIT

### CAUTION

Please use the included battery pack and a power adaptor only. Do not disassemble or attempt to use alternative battery packs.

Remove and keep the battery separately if the device is not used for more than a month. It may require several charge-discharge process before a battery regains its full capacity after a long storage period.

1. Connect Battery pack to the main unit.

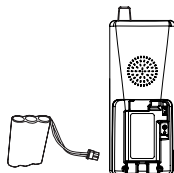

2. Connect AC adapter to Charging Cradle

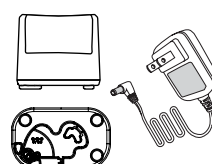

3. Press and hold "OFF" button to power on. Set the unit onto the cradle for charging.



## 6. PAIRING WITH OTHER iVISION+ DEVICES

NOTE: One Handheld Monitor Unit (IVP-HU) must be configured to have a HOME ID\*1 prior to pairing with other iVISION+ devices. Handheld Monitor Unit bundled with Door Camera Unit already has a HOME ID set up and paired up to each other.

\*1 HOME ID is a unique network identification protocol for iVISION+ system. One Handheld Monitor Unit can issue the HOME ID and all other devices on the same system must be assigned the same HOME ID.

### 6-1 How to create HOME ID by a Handheld Monitor Unit

#### WARNING

Any pre-existing HOME ID set up will be cleared out with this procedure.

- 1) Press pairing button once in the back of the unit. The IVP-HU will be in a pairing mode.
- 2) Press the pairing button again and hold until the unit makes a beep sound.
- 3) Press "Left function key" on the front to confirm "CREATE."

### 6-2 How to enroll other iVISION+ devices to the Handheld Monitor Unit

- 1) Press pairing button in the back of IVP-HU. The unit will be in "PAIRING MODE".
- 2) Proceed to "SCAN" by pressing "Left function key". IVP-HU starts scanning for other devices for 60 seconds.
- 3) Prepare other iVISION+ device into their pairing mode. (REF: 6-3)  
When the device is ready, the new unit will be enrolled to the HOME ID and IVP-HU shows which device was connected.
- 4) If another device needs to be enrolled, re-enter "SCAN" by "Left Function key" and repeat the process.

## 7. OPERATION CHECK

### 7-1 Confirming number of iVISION+ devices in a HOME ID

- (1) In a normal operation mode, press and hold the left function key for two seconds to enter menu mode.
- (2) Select menu number 3 # DEVICES IN NETWORK by up and down key.
- (3) Press LEFT function key to "OK"
- (4) The display will show the number of iVISION+ devices in the network. Confirm number of iVISION+ devices registered with the HOME ID.
- (5) Maximum numbers of devices in an iVISION+ system are;  
2 IVP-DU, 2 IVP-GU and 4 IVP-HU. Go over pairing procedure unless optimal numbers of devices are displayed.



### 6-3 REFERENCE: How to enter "pairing mode" in iVISION+ devices

#### IVP-DU: Door Camera Unit

If not purchased in a bundle package, IVP-DU is in the pairing mode when powered up. IVP-DU beeps continuously when PUSH button is pressed. To purposely enter into a pairing mode, press PUSH button once and hold a pairing button in a back.

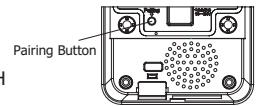

#### IVP-HU: Handheld Monitor Unit

If not purchased in a bundle package, IVP-HU is in the pairing mode when powered up. Choose "JOIN" by "Right function key" to enroll into an existing HOME ID. If otherwise, follow the instruction 6-1 to create a new HOME ID. After an enrollment of new HU, reset a Time & Date on HU1 to reflect the setting onto the added HU unit.

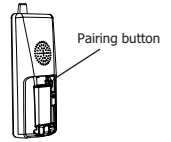

#### IVP-GU: Gateway Chime Unit

If not purchased in a bundle package, by the factory default, IVP-GU is in the pairing mode when powered up. IVP-GU beeps continuously and green/red LED blinks. Press down both A and B buttons while powering up the Gateway Chime Unit to enter the pairing mode.

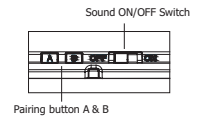

## 7. OPERATION CHECK

### 7-2 Checking operations on Handheld Monitor Unit

- (1) Make sure IVP-HU has been charged and there is a green indication on the top of display.
- (2) To confirm RF reception, bring IVP-HU and IVP-DU in a line of sight.
- (3) Press "Push button" on a paired Door Camera Unit.  
All paired IVP-HUs display an image from the IVP-DU.
- (4) Press "Answer" on any of the IVP-HU.  
Voice from IVP-HU will be heard from the IVP-DU.
- (5) Press "OFF" on the IVP-HU to terminate the communication.
- (6) Move IVP-HU (and IVP-DU) to a desired location and repeat (3) to (5) to confirm reception of signals.

## 8. SPECIFICATION

### 8-1 Dimensions

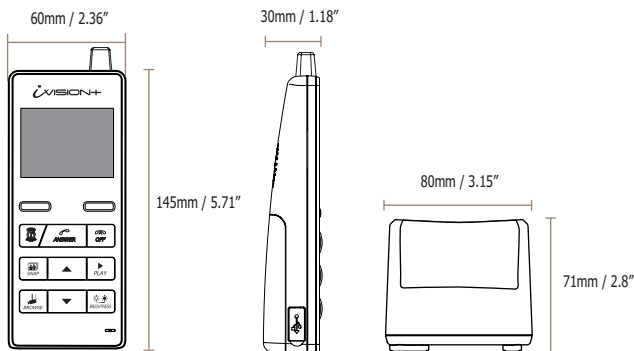

### 8-2 Specification Table

MODEL NAME: OPTEX iVISION+ (IVP-HU) Handheld Monitor Unit

Operating Temperature	0 to 40 degC (32 to 104 degF)
Operating Humidity	< 90% RH (no condensation)
Warranty	1 year
Dust/Water Protection	N/A (Indoor Use Only)
Radiowave Frequency	2.4 GHz
Power	Power Adaptor 5.5V DC

Use designated battery, IVP-BAT, for IVP-HU.

Please contact your regional technical support for procurement information.

## 9. WARRANTY

1. This product is warranted under normal use for 1 year from the date of purchase. If the product proves to be defective, return it with a copy of your dated sales receipt for repairs or replacement without charge.
2. The warranty is not applicable when below circumstances will be found:
  - Mechanical or electrical modification(s) are made to the product or it is otherwise altered manually.
  - The product is already been at place(s) other than the manufacturer.
  - It is determined that the product malfunction has resulted from improper use or from an accident.
  - No copy of the dated sales receipt has been submitted together with the product to be served.



#### OPTEX CO., LTD. (JAPAN)

5-8-12 Ogoto Otsu  
Shiga 520-0101  
JAPAN  
TEL: +81-77-579-8670  
FAX: +81-77-579-8190  
URL: <http://www.optex.co.jp/e/>  
(ISO 9001 Certified)  
(ISO 14001 Certified)

#### OPTEX INCORPORATED (USA)

13661 Benson Ave., Bldg. C  
Chino, CA 91710  
U.S.A.  
TEL: +1-909-993-5770  
Tech: (800)966-7839  
URL: <http://www.optexamerica.com/>



Wireless Video Intercom

### FCC Statement

This device complies with Part 15 of the FCC Rules. Operation is subject to the following two conditions: (1) This device may not cause harmful interference, and (2) this device must accept any interference received, including interference that may cause undesired operation. Any Changes or modifications not expressly approved by party responsible for compliance could void the user's authority to operate the equipment.

Note: This equipment has been tested and found to comply with the limits for a Class B digital device, pursuant to part 15 of the FCC Rules. These limits are designed to provide reasonable protection against harmful interference in a residential installation. This equipment generates, uses and can radiate radio frequency energy and, if not installed and used in accordance with the instructions may cause harmful interference to radio communications. However, there is no guarantee that interference will not occur in a particular installation. If this equipment does cause harmful interference to radio or television reception, which can be determined by turning the equipment off and on, the user is encouraged to try to correct the interference by one or more of the following measures:

- Reorient or relocate the receiving antenna.
- Increase the separation between the equipment and receiver.
- Connect the equipment into an outlet on a circuit different from that to which the receiver is connected.
- Consult the dealer or an experienced radio/TV technician for help.

### Radiation Exposure Statement

This equipment complies with FCC radiation exposure limits set forth for an uncontrolled environment. This transmitter must not be co-located or operating in conjunction with any other antenna or transmitter.(see \*\* )

### IC RSS warning

This device complies with Industry Canada licence-exempt RSS standard (s). Operation is subject to the following two conditions: (1) this device may not cause interference, and (2) this device must accept any interference,including interference that may cause undesired operation of the device.

Le présent appareil est conforme aux CNR d'Industrie Canada applicables aux appareils radio exempts de licence.

L'exploitation est autorisée aux deux conditions suivantes:

- (1) l'appareil ne doit pas produire de brouillage, et
- (2) l'utilisateur de l'appareil doit accepter tout brouillage radioélectrique subi, même si le brouillage est susceptible d'en compromettre le fonctionnement.

Under Industry Canada regulations, this radio transmitter may only operate using an antenna of a type and maximum (or lesser) gain approved for the transmitter by Industry Canada. To reduce potential radio interference to other users, the antenna type and its gain should be so chosen that, the equivalent isotropically radiated power (e.i.r.p.) is not more than that necessary for successful communication.

Conformément à la réglementation d'Industrie Canada, le présent émetteur radio peut fonctionner avec une antenne d'un type et d'un gain maximal (ou inférieur) approuvé pour l'émetteur par Industrie Canada. Dans le but de réduire les risques de brouillage radioélectrique à l'intention des autres utilisateurs, il faut choisir le type d'antenne et son gain de sorte que la puissance isotrope rayonnée équivalente (p.i.r.e.) ne dépasse pas l'intensité nécessaire à l'établissement d'une communication satisfaisante.

(1/2) This radio transmitter (identify the device by certification number, or model number if Category II) has been approved by Industry Canada to operate with the antenna types listed below with the maximum permissible gain and required antenna impedance for each antenna type indicated. Antenna types not included in this list, having a gain greater than the maximum gain indicated for that type, are strictly prohibited for use with this device.

Le présent émetteur radio (identifier le dispositif par son numéro de certification ou son numéro de modèle s'il fait partie du matériel de catégorie I) a été approuvé par Industrie Canada pour fonctionner avec les types d'antenne énumérés ci-dessous et ayant un gain admissible maximal et l'impédance requise pour chaque type d'antenne. Les types d'antenne non inclus dans cette liste, ou dont le gain est supérieur au gain maximal indiqué, sont strictement interdits pour l'exploitation de l'émetteur.

### IC Radiation Exposure Statement:

This equipment complies with IC RF radiation exposure limits set forth for an uncontrolled environment. This transmitter must not be co-located or operating in conjunction with any other antenna or transmitter. (see \*\*)

\*\* For DU and GU, the equipment should be installed and operated with minimum distance 20cm between the radiator & your body.