

# Easikey

## Installation and User Guide

17086 Ver 3.3 DRAFT C January 2003

Changes are periodically made to the product, these changes will be incorporated into new editions of this manual. PAC INTERNATIONAL LTD shall not be liable for errors contained herein or for any consequential damages connected with the use of this material.

**Copyright and Protective Notices**

1. The copyright of this document and the associated drawings is the property of PAC INTERNATIONAL LTD, and is issued on condition that it is not copied, reprinted or reproduced, nor its contents disclosed, either wholly or in part, without the consent in writing of, or in accordance with the conditions of a contract with PAC INTERNATIONAL LTD.
2. The publication of information in this document does not imply freedom from patent or other protective rights of PAC INTERNATIONAL LTD, or others.
3. Performance figures and data quoted in this document are typical, and must be specifically confirmed by PAC INTERNATIONAL LTD before they become applicable to any tender, order or contract.

**Training and Technical Support**

**Training courses** covering the installation and use of all PAC products are regularly held at PAC INTERNATIONAL LTD, Stockport. For further information on course availability, or to discuss your specific requirements, contact the Training Manager at the address below.

**It is strongly recommended that any persons installing or commissioning PAC products attend a suitable training course beforehand.**

**Technical Support** for all PAC products is available during normal office hours:

8:00am to 6:00pm Monday to Friday, excluding public holidays.

**Tel: 0161 406 3400**

**International +44 161 406 3400**

**Fax: 0161 430 8658**

**International +44 161 430 8658**

This service is provided primarily for the use of trained engineers. End users of PAC products should first of all contact their installation or maintenance company before contacting PAC.

**PAC INTERNATIONAL LTD****1 Park Gate Close****Bredbury****Stockport****SK6 2SZ****England**

---

**IMPORTANT:**

When installing the PAC equipment the following should be noted:

**HEALTH AND SAFETY**

Installation must be wired in accordance with National Wiring Regulations (BS7671, IEE National Wiring Regulations in the UK). Failure to do so can result in injury or death by electric shock.

It must also comply with any local Fire, Health and Safety regulations. A secured door that may be part of an escape route from an area must be fitted with:

- A fail-safe lock (A) so that the door will be released if the power fails. Ideally a magnetic lock should be used as these are less likely to jam or seize.
- A normally-closed break-glass or manual pull (B) in the lock supply wiring so that in an emergency the fail-safe lock can be immediately depowered.

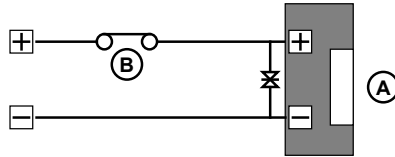

The controller must be earthed.

Isolate the controller supply before working on the controller.

**CABLING**

The cabling used in the PAC Access Control Systems (six wire bus, reader cables, etc.) are not prone to electrical interference. However, you should avoid routing cable close to heavy load switching cables and equipment. If this is unavoidable, cross the cable at right angles every 3.3-6.6ft/1-2m to reduce the interference.

**RFID Devices**

As similar RFID technology is now widely used in a number of other industries, for example automotive immobilisers, it is possible that interaction between your access control ID and other devices may cause one or the other to function incorrectly. Should you suspect that you have experienced such a problem the solution is to separate your access control ID from other RFID devices.

**FCC Notice**

This device complies with part 15 of the FCC rules. Operation is subject to the following two conditions (1) this device may not cause harmful interference, and (2) this device must accept any interference received, including interference that may cause undesired operation.

**FCC ID OQL-EK-CON**

Changes or modifications not expressly approved by the party responsible for compliance could void the user's authority to operate the equipment.

**Note**

This equipment has been tested and found to comply with the limits for a Class B digital device, pursuant to part 15 of the FCC Rules. These limits are designed to provide reasonable protection against harmful interference in a residential installation. This equipment generates, uses and can radiate radio frequency energy and, if not installed and used in accordance with the instructions, may cause harmful interference to radio communications. However, there is no guarantee that interference will not occur in a particular installation. If this equipment does cause harmful interference to radio or television reception, which can be determined by turning the equipment off and on, the user is encouraged to try to correct the interference by one or more of the following measures:

- Reorient or relocate the receiving antenna.
- Increase the separation between the equipment and receiver.
- Connect the equipment into an outlet on a circuit different from that to which the receiver is connected.
- Consult the dealer or an experienced radio/TV technician for help.

---

This page is intentionally left blank.

---

## Table of Contents

1.1 Facilities .....	1
1.2 Features.....	3
1.3 About this Guide .....	3
2.1 Components .....	4
2.2 How it Works.....	4
2.3 Programming .....	4
3.1 Worksheets.....	5
3.2 Editor Keys .....	5
3.3 Administering Keys .....	5
3.4 Residential Systems .....	5
3.5 Easikey User Guide.....	5
4.1.1 1. Present the new key to the controller reader.....	6
4.2 Possible Problems.....	6
5.1.1 1. Present the key to the controller reader. ....	7
7.1.1 Dimensions.....	8
7.1.2 Environment .....	8
7.1.3 Power Requirements.....	8
7.1.4 Fuses.....	8
7.1.5 Cable Requirements.....	8
9.1 The Easikey Controller .....	10
9.2 Terminal Blocks .....	10
9.3 Power Supply.....	11
9.3.1 Connecting Power .....	11
9.4 Battery Backup .....	11
9.5 Readers .....	12
9.5.1 Request To Exit (RTE) .....	12
9.6 Reader Wiring.....	12
9.7 Installing Locks and Power Supply.....	13
9.7.1 Lock Suppression.....	13
9.8 Note: Health and Safety.....	13
9.9 Checking the System.....	14
9.9.1 Controller Fuse.....	14
9.9.2 Switches .....	14
10.1 Initialisation .....	15
10.2 Adding the Editor Keys .....	15
10.3 Setting the Lock Time.....	15
10.4 Replacing a Lost Editor Key 1 .....	16
13.1 Reader Wiring.....	18
13.2 Lock Wiring .....	18
13.3 Programming .....	19

---

This page is intentionally left blank.

# 1. Introduction

**Easikey 2-Door Controller:**

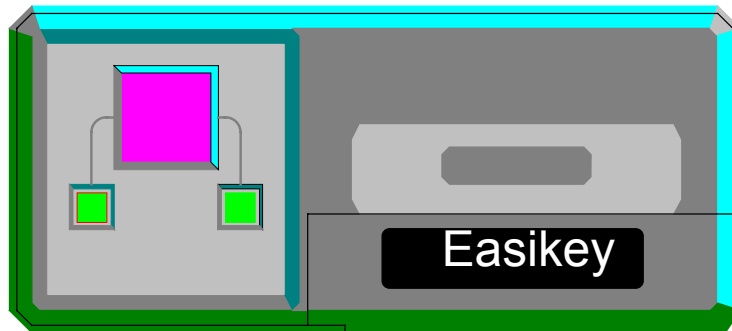

**Easikey Readers (Supplied Separately):**

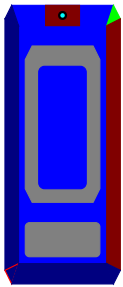

**Mullion Reader**

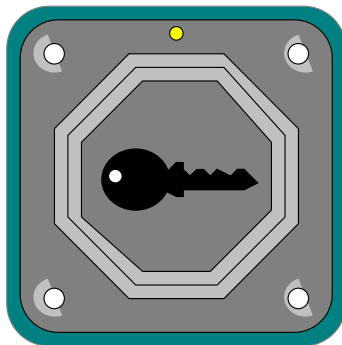

**Vandal Resistant Reader**

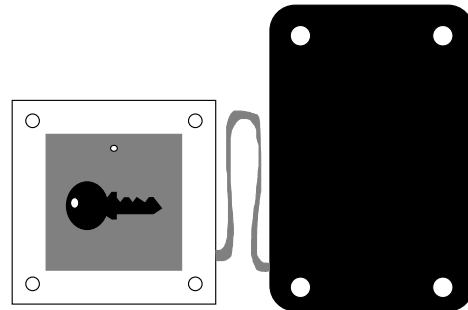

**Easikey Panel Mount Reader**

## 1.1 Facilities

- Simple Proximity Access Control
- Three Types of Reader
- Controls One or Two Doors
- Up to 99 Keyholders
- Up to Three Editor Keys
- Individual Keys may be Added and Deleted
- Each Lock may be Fail-Safe or Fail Secure
- Request to Exit Input
- Set/Reset Option, (e.g. for Alarm Setting)
- Dual Controller Option - 2 Doors, 198 Keyholders

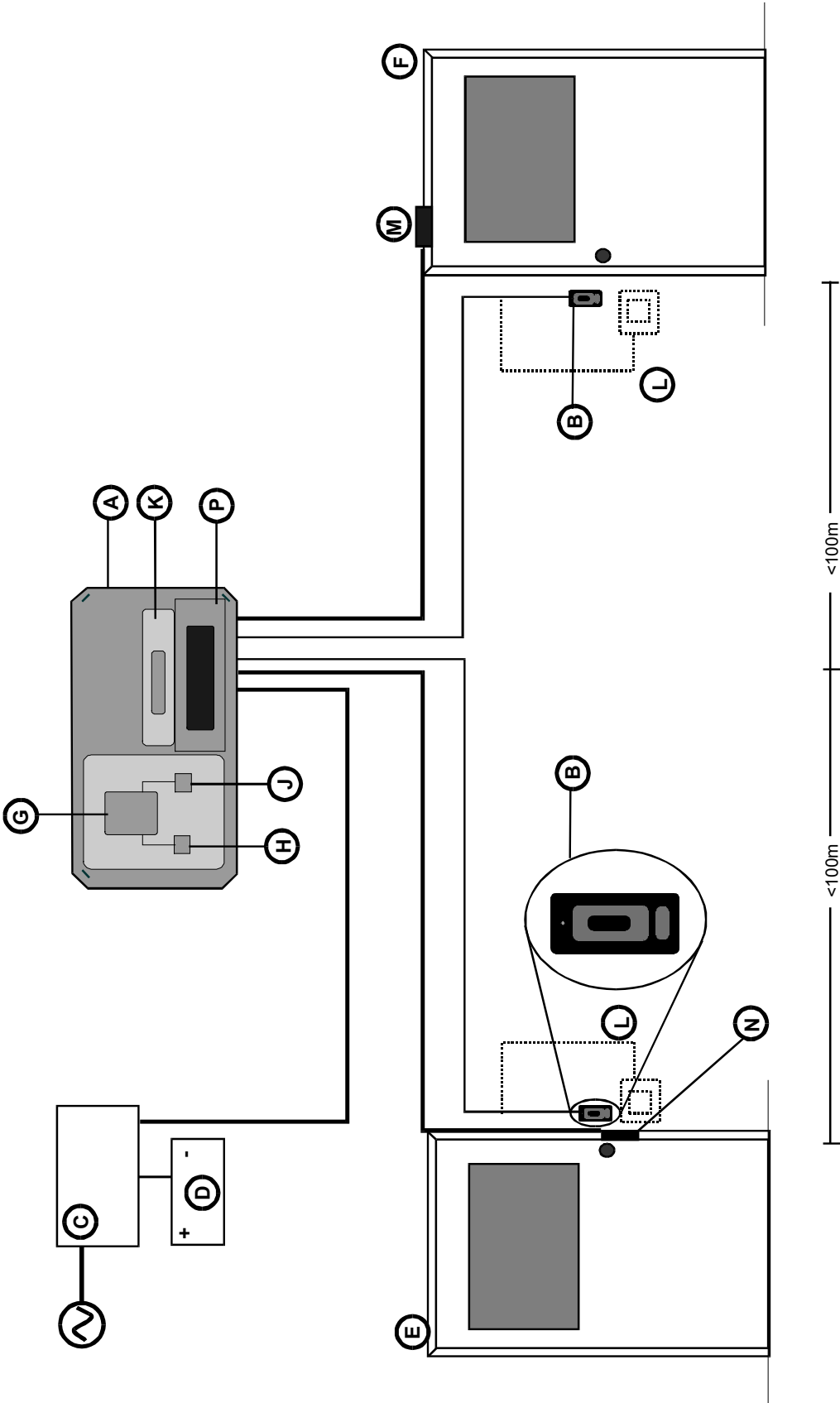

### Easikey System Configuration

<b>A</b>	Easikey Controller Easikey Reader Power Supply for Controller, Readers and Locks Battery Backup	<b>E</b> <b>F</b>	Door 1 Door 2	<b>G</b> <b>H</b> <b>J</b> <b>K</b> <b>P</b>	Programming Display Blue Button Grey Button Controller Reader Removable Cover	<b>L</b> <b>M</b> <b>N</b>	Request to Exit Switch (on other side of door) Example: Magnetic Lock Example: Electric Release
----------	-------------------------------------------------------------------------------------------------------------	----------------------	------------------	----------------------------------------------------------	-------------------------------------------------------------------------------------------	----------------------------------	----------------------------------------------------------------------------------------------------------

<b>Readers may be:</b>	Mullion Reader (shown) Vandal Resistant Reader Panel Mount Reader	<b>Locks may be:</b>	Fail Secure, e.g. Electric Release Fail Safe, e.g. Magnetic Lock
------------------------	-------------------------------------------------------------------------	----------------------	---------------------------------------------------------------------



## 1.2 Features

<b>Maximum Number of Keys</b>	99
<b>Number of Doors</b>	2
<b>Types of Reader</b>	Mullion (Black or White) Vandal Resistant (Steel or Brass) Panel Mount
<b>Access Levels</b>	3, (allowed through Door 1, Door 2 or Both Doors)
<b>Lock Release Time</b>	1-48 seconds
<b>Lock Type</b>	Fail-Safe or Fail-Secure
<b>Number of Editor Keys</b>	Selectable (1,2 or 3)
<b>Other Features:</b>	Request to Exit Input Set/Reset Latch Database Copy Display Last 5 Users

## 1.3 About this Guide

This document contains details on installing and using the Easikey system. **Users** and **Administrators** should read the section *How to Use Easikey*. This section also describes how to use the **Worksheets** provided. Users should also read the sections on *Adding Keys*, *Deleting Keys* and *Show Last Five Users*. These sections are repeated on a one page **User Guide** included with the controller.

**Installers** should read all of this Guide before continuing with the installation of the system. If you are already familiar with this product then there is a *Quick Start* section which will remind you of the stages of installing and programming the system.

## 2. Description

Easikey is a simple two door access control system using PAC's proximity readers and electronic keys. The system allows you to control the access of up to 99 keys through one or two doors.

### 2.1 Components

An Easikey system consists of an Easikey door controller, one or two Easikey readers and up to 99 keys. In addition you will require a power supply, cable and suitable electric locks. Optional items include Request to Exit switches and backup batteries. PAC also manufacture a **Boxed Easikey**, consisting of an Easikey controller housed in a steel cabinet, complete with 3A power supply, space for backup batteries and complete internal wiring.

### 2.2 How it Works

Each PAC key contains a unique code. The controller can store the code of up to 99 keys in its non-volatile memory. When a key is presented to a reader, the code in the key is passed by the reader to the controller. It is then compared to the codes in the controller's memory. If the key is recognised by the controller then a relay will be operated allowing the release of an electric lock.

### 2.3 Programming

An Easikey system is programmed through the use of **Editor Keys**. The first one, two or three keys in the controller's memory are defined as Editor Keys - you select how many at installation. By use of the Editor Keys, an operator may add and delete keys from the controller's memory using the built-in reader.

A two digit display is used to indicate key numbers and lock times. The display also includes two LEDs (light emitting diodes), red and green, for providing extra indications depending on the type of operation being performed.

## 3. How to Use Easikey

This section describes how you should use your Easikey system to its best advantage. Anyone operating or administering the system should read this section as well as becoming familiar with *Adding Keys* and *Deleting Keys*.

### 3.1 Worksheets

Supplied with each Easikey controller is a set of worksheets. These should be used for recording information about the system as well as for keeping a record of keyholders. The following paragraphs refer to the worksheets and how best to use them.

### 3.2 Editor Keys

An Easikey controller can store up to 99 keys in its memory. Every one of these keys can be allowed through Door 1 only, Door 2 only or both doors. Up to three of these keys, known as **Editor Keys**, are also given the ability to make changes to the system - such as adding new keys or deleting existing keys. When the system is first installed the number of Editor Keys is set to 1, 2 or 3, that is key numbers 1, 2 and 3. You should know how many keys are Editor Keys, if you do not, then find out from whoever installed the system. Note that there is a section on the *Programming Worksheet* to record this number.

It is recommended that you assign two or three keys as editors, and keep at least one in a safe place. Editor keys can be deleted and added just like normal keys. However if all your Editor Keys are lost then you will have to follow the procedure to replace Editor Key 1. You cannot change the *number* of Editor Keys without clearing the whole memory.

### 3.3 Administering Keys

Each key added to the system is given a number, 01-99. The lowest available number is displayed when a new key is presented, although this can be changed to another unused number if necessary. When a key is deleted from the Easikey's memory, its number becomes available again.

When you add a key to the Easikey system you need to record the number (01-99) it was given, and to whom it was issued. This is important so that if the keyholder loses the key you can delete it by entering its 2-digit number. Use the Worksheets supplied for this purpose.

You can identify keys that have been found by presenting them to the controller reader. Their 2-digit number will be displayed, along with a red light. (If a green light is displayed, it means the key is unknown to the Easikey).

The worksheet has an unlabelled column in the keyholder section. You can use this for recording your own information. Typically you may record Department or Office in a commercial system, or Flat, Building or Block in a residential system.

Five different coloured pegs are available. These fit into the small hole on one side of the PAC key. You can use these pegs to identify different keys issued to one keyholder. A residential system, for instance, may issue a red, blue and yellow key to one resident for use by the occupants of one dwelling. If one key is lost they can refer to their 'red key' as being missing. The worksheets contain a column for indicating the colour given to a key.

A grid on one side of the PAC key can also be used for physically marking a key. You put a small scratch, or drop of paint or correcting fluid, in different boxes to identify individual keys.

### 3.4 Residential Systems

A special worksheet is included that is designed for use in Residential applications. This is divided into two parts, **Non-Residents** and **Residents**. You should use the top section for recording personnel such as cleaners, maintenance staff, housing officers etc. and the lower section for the residents.

### 3.5 Easikey User Guide

A one page *User Guide* (17085) is included with each door controller. This repeats most of the page in this document on *Adding and Deleting Keys*.

#### Note

This page is reproduced as the *Easikey User Guide* (17085) included with the Easikey controller.

## 4. Adding Keys

The Easikey controller stores up to 99 keys in its memory. Each key is given a number from 1 to 99. When a key is deleted from memory its number is free to be used again. When adding a key it is automatically assigned the first free number. The operator can however, select a different number, provided it is not being used by another key.

### 4.1.1 1. Present the new key to the controller reader.

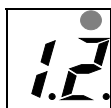

If the new key is valid then the first free number between 1 and 99 will appear with a green LED. In this example key 12 is the first free number.

### 2. To select a different number:

- Press both buttons together. The display will flash briefly.
- Select another number by using the grey button to increment the right hand digit and the blue button to increment the left hand digit. If a number is already used then the display will flash.
- When the number required is selected press both buttons again.



### 3. To Change the Access Level:

The two small dots represent door 1 and door 2. When lit they indicate that the key has access through those doors.

- To prevent a key from gaining access to one of the doors press the blue (door 1) or grey (door 2) button. The corresponding dot will go out.
- To allow access again press the same button again - the dot will come back on. In this example key 12 will have access to door 1 only.

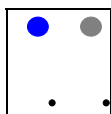

### 4. Present an Editor Key to the controller reader.

The key is now confirmed as in the controller's memory and the display will clear, except for the green LED. and the access level dots.

At this point you may:

- Present the same Editor Key to clear the display.
- Allow the display to time-out after 15 seconds.
- Present another key to be added.

### 5. Block Adding Keys

Once a key has been added as above then further keys can be added by presenting them to the controller reader one after the other. You do not need to present an Editor Key again. Each key will be given the next free number, which can be changed as described above. Also the access level will stay the same from one key to the next, unless changed.

## 4.2 Possible Problems



### Key Already In Memory

If the key already exists in the controllers memory then its number, **01-99**, will appear in the display with the red LED. lit.



### Memory Full

If the Easikey is full then **00** will appear, flashing, in the display.

## 5. Deleting Keys

There are two ways of deleting a key:

**If you have the key then:**

5.1.1 1. Present the key to the controller reader.



2. If the key is in the controller's memory then its number will appear in the display with the red LED. lit. (If the key is not in memory then the next free number will be displayed with the green LED. lit. )

3. Present an Editor Key to the controller reader. The display will flash briefly and the display will clear. The key is now deleted.

**If you do not have the key:**



1. Use the blue and grey buttons to enter the key number. Press the grey button - the display will change to **00** with the red LED. lit. Press the blue button to increment the left hand digit, the grey button to increment the right hand digit.

2. If the number displayed is not used then the digits will flash.



3. When you have selected the key number to be deleted, present an Editor key to the controller reader. The display will flash briefly and the display will clear. The key is now deleted.

### Editor Keys

When the Easikey was installed the number of Editor keys was set to 1,2 or 3. This means the first 1,2 or 3 keys will be Editors. If an Editor key is deleted, then a key added back with the same number will also become an Editor. Editor keys can only be deleted by the second method described above, neither can an Editor key delete itself.

## 6. Show Last Five Users

It is possible to see the last 5 keys used by pressing the blue button. Press the button once to see the last key used - the dot indicates which door was used, door 1 - left dot, door 2 - right dot. Press the blue button again to see the previous keys used. Once the last 5 keys have been viewed the display will clear.

## 7. Specification

### 7.1.1 Dimensions

Controller (WxHxD, mm) 198 x 90 x 28

Readers see *17063 Easikey Reader Data Sheet*

### 7.1.2 Environment

Temperature Controller 0C to +50C  
Reader -15C to +60C

Humidity (RH) Controller 0% to 90%  
(non-condensing)  
Reader Sealed Construction

### 7.1.3 Power Requirements

Controller: Input Voltage 10.5v to 20v DC  
8v to 14.5v AC 50/60Hz  
Current 190mA (Max.)  
Reader: Current 90mA (Max.)

### 7.1.4 Fuses

F1, Power fuse on PCB, 1A, 20mm glass, Quick Blow

### 7.1.5 Cable Requirements

Controller to Reader:  
Gauge 0.22mm<sup>2</sup>, 4 or 6 core  
Max. Dist. 100m

Controller to Lock:  
Gauge 0.5mm<sup>2</sup>, 2 core  
Max. Dist. 100m

## 8. Quick Start

If you have installed an Easikey system before then you can follow this simple step-by-step procedure to get the system up and running.

If you are new to Easikey then all the steps below are described in detail in the following pages.

1. Install the Easikey controller, complete with power supply, in an enclosure or other secure area. (The Boxed Easikey, 21275, makes this stage easier)
2. Install the readers and reader cables, including request to exit switches, if used.
3. Install the electric locks and their cables.
4. Initialise the Easikey, set the number of Editor Keys and add one or more keys.
5. Set the lock release time for each lock.
6. Check the operation of each reader and lock.
7. Add any remaining keys to the controller - use the Worksheet to record details of keyholders.

## 9. Installation

Installation is only to be carried out by competent, qualified and experienced personnel.

Wire in accordance with the country of installation's National Wiring Regulations (UK BS7671, IEE National Wiring Regulations). Failure to do so can result in injury or death by electric shock.

Note that a 'Boxed Easikey' (Part No. 21275) is available, complete with cabinet, 3 Amp power supply, internal wiring and space for two 6Ah batteries. If this is being used then follow the instructions supplied with it for installation and power supply.

### 9.1 The Easikey Controller

The controller should be mounted in a lockable cabinet or enclosure containing the power supply and batteries (if used). It should be easily accessible for programming - the display should be at about eye level. A mounting plate is provided. When using the mounting plate use two countersunk screws. Take care not to over-tighten the screws as distortion of the backplate may make it difficult to mount the controller.

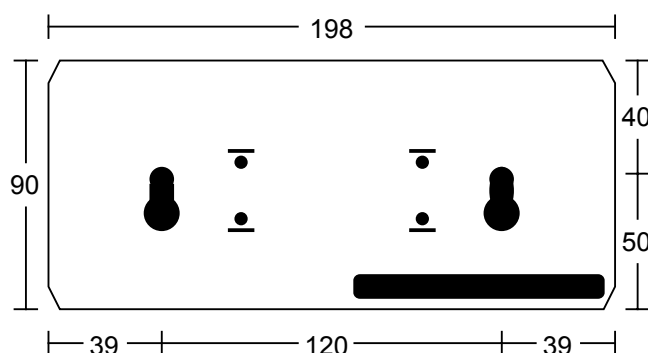

Easikey Backplate Dimensions (mm)

### 9.2 Terminal Blocks

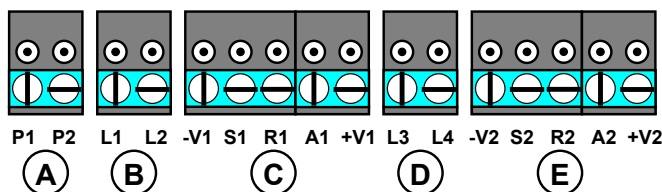

	Terminal Markings	Function
<b>A</b>	P1 P2	Power Input, AC or DC
<b>B</b>	L1 L2	Lock 1 Output
<b>C</b>	-V1 S1 R1 A1 +V1	Reader Channel 1
<b>D</b>	L3 L4	Lock 2 Output
<b>E</b>	-V2 S2 R2 A2 +V2	Reader Channel 2

All connections are made to the controller by removable terminal blocks. Always remove power from the controller before removing a terminal block.



## 9.3 Power Supply

The Easikey controller and readers are powered from a 12v AC or DC power supply. The locks are controlled by switching power from the same or different supply. The relays that control the locks are able to switch 24v AC or DC at up to 2 Amps. A power supply with battery backup should be selected to provide operation when mains power is lost.

The power supply chosen should be capable of supplying sufficient current to power the Easikey controller, one or two Easikey readers, one or two electric locks and provide charging current for the battery.

Use the following table to ensure you do not overload the power supply:

Item	Current (mA)
Easikey Controller	190
Easikey Reader 1	90
Easikey Reader 2	90
Lock 1	
Lock 2	
Charging Current	500
Safety Margin	500
<b>Total</b>	

The total current should not exceed the rating of your power supply (or supplies).

### 9.3.1 Connecting Power

Power is supplied through the P1 and P2 terminal block. See the section *Installing Locks* for details of power and lock wiring.

## 9.4 Battery Backup

The length of time that a backup battery will last depends on the power consumption of the system. The main factor in this calculation is the power consumption of the locks. A *fail-safe* lock draws current continuously and therefore you add the *continuous* current to the total. A *fail-secure* lock only draws current when it operates. In this case you need to estimate how often the lock will operate and use the following equation to estimate consumption:

$$\text{Lock Current(mA)} \times (\text{no. of operations per hour} \times \text{lock release time (secs)}) / 3600$$

**Example:** a 500mA lock operating 100 times an hour for 5 seconds would use  $500 \times (100 \times 5) / 3600 = 69\text{mA}$  per hour.

Once the total power consumption has been estimated then it can be calculated how long the fully charged batteries will last. The Ah rating of batteries is usually given as a 10 hour discharge rate. If the batteries discharge over a shorter period of time they will last for less than their quoted capacity.

**Example:** an Easikey with two readers and two continuous (fail-safe) locks each drawing 250mA would consume  $190 + 90 + 90 + 250 + 250 = 870\text{mA}$ . A fully charged 12Ah battery would last  $12 / 0.870 = 13.7$  hours.

## 9.5 Readers

Install readers according to the instructions supplied with each reader. Readers are usually installed at about door handle height on the unhinged side of the door.

All readers have the same wiring terminals, and are fitted with a green led that illuminates when access is allowed., and stays illuminated for the duration of the lock release time.

The maximum distance of a reader from the controller is **100m**.

If two readers are fitted then they must be at least **300mm** apart.

**You must only use Easikey readers - no other type of reader is suitable.**

### 9.5.1 Request To Exit (RTE)

A Request to Exit switch may be fitted on the secure side of the door. This should be a normally-open switch that closes momentarily when pressed and released. Do not allow the wiring for the RTE switch to be visible if the reader is removed from the wall.

## 9.6 Reader Wiring

If you do not intend to use the RTE switch then 4-core cable will be suitable, otherwise use 6-core cable.

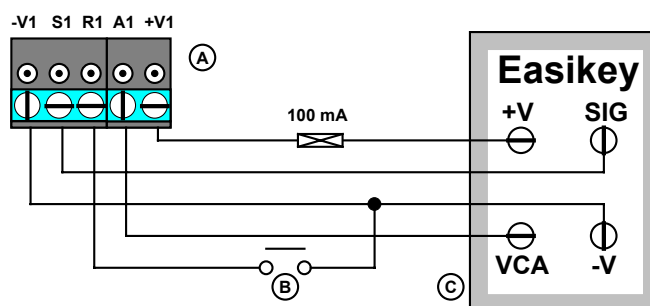

**Reader Wiring, including RTE**

<b>A</b> Terminal Block	<b>B</b> RTE	<b>C</b> Reader
-------------------------	--------------	-----------------

Use 7/0.2mm (0.22mm<sup>2</sup>) 4-core or 6-core unshielded cable.

Controller:		Reader:	Colour:
Channel 1	Channel 2		
+V1	+V2	+V	Red
S1	S2	SIG	Blue
R1	R2	n/c	White
A1	A2	VCA	Yellow
-V1	-V2	-V	Black

#### Note

PAC strongly recommend that you fit a 100mA in-line fuse across the reader supply.

## 9.7 Installing Locks and Power Supply

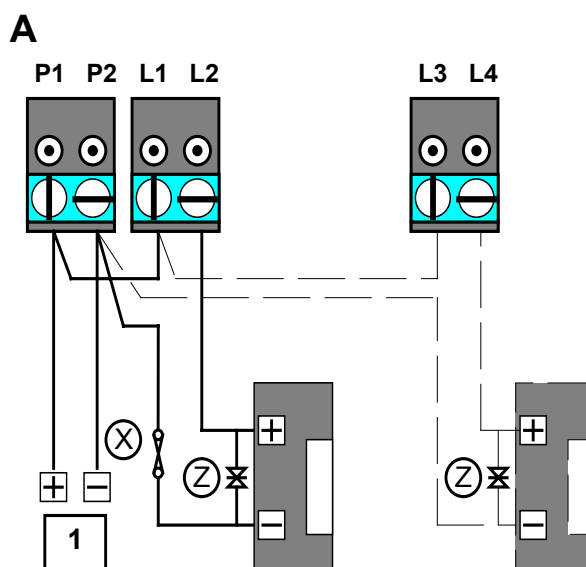

<b>A</b> Single Power Supply
<b>X</b> Fuse <b>Z</b> MOV

Locks should be installed according to the manufacturers instructions. The Easikey controls the operation of a lock by switching power using a voltage-free relay. Up to 24v AC or DC at 2 Amps may be switched by the relays. Each lock may be programmed to be fail-safe (continuously powered, power removed to unlock) or fail-secure (power supplied to unlock). The type of cable used should be sufficient to provide the correct operating voltage at the lock. Usually at least 0.5mm<sup>2</sup> will be required for up to **100m**.

### 9.7.1 Lock Suppression

**Important:** All Easikey readers are supplied with a suppression device, an MOV (metal oxide varistor). This device should be fitted across the lock supply **at the lock**. These devices prevent harmful back e.m.f. ('spikes') from damaging the Easikey controller. **Failure to fit these devices may result in long term damage to the controller.**

## 9.8 Note: Health and Safety

Any installation **must** comply with any local Fire, Health and Safety regulations. A secured door that may be part of an escape route from an area should be fitted with:

- A **Fail-Safe** lock (**A**). So that the door will be released if the power fails. Ideally a magnetic lock should be used as these are less likely to jam or seize.
- A normally-closed **Break-Glass** or **Manual Pull** (**B**) *in the lock supply wiring*. So that in an emergency the fail-safe lock can be immediately depowered.

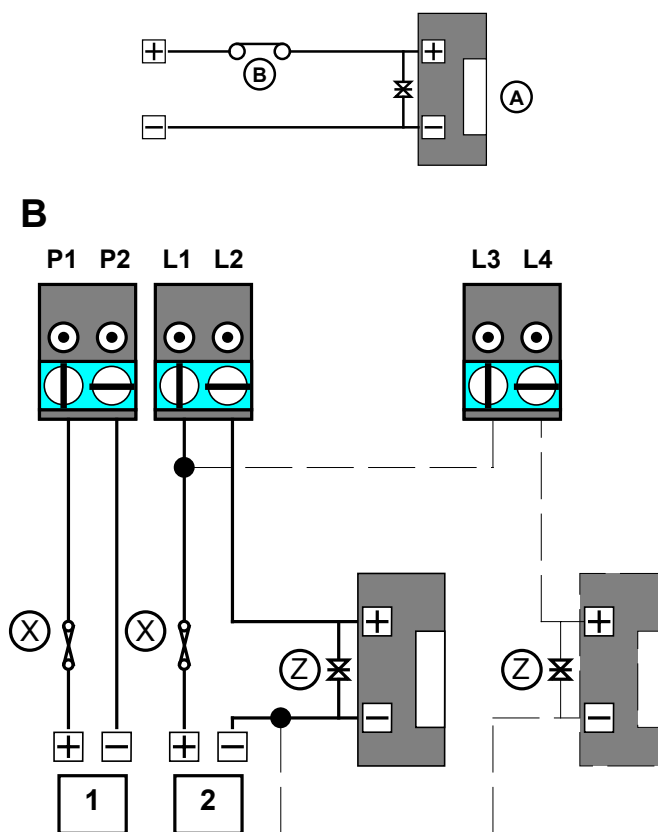

**B** Separate Power Supply for Controller and Lock  
**X** Fuse                      **Z** MOV

## 9.9 Checking the System

After completing the wiring of power supply, readers and locks you should make the following checks:

1. Remove power. Remove all terminal blocks except for the power supply (P1 & P2). Apply power. You should have between 10.5 and 20v DC or between 8 and 14.5v AC across P1 and P2.
2. Remove power. Connect Reader 1 terminal block. Apply power. You should have between 10 and 16v DC *at the controller* (+V1, -V1) and 9-16v DC *at the reader* (+V, -V).
3. Repeat for Reader 2, if used.

### 9.9.1 Controller Fuse

A 20mm 1 Amp fast blow fuse is fitted to the controller protecting both the controller and reader supplies.

### 9.9.2 Switches

Four switches are visible inside the controller near the fuse. These should always be off (switches towards the fuse).

## 10. Initial Programming

The initialisation of the controller involves clearing its memory and assigning the number of Editor Keys that will be used. **Once the number of Editor Keys has been set then the number cannot be changed without clearing the Easikey memory.** However Editor Keys can be removed and added - see *Adding and Deleting Keys*.

Record the number of Editor Keys on the Programming Worksheet.

### 10.1 Initialisation

**Note: This will clear the memory of the Easikey**

1. Power up the Easikey with both buttons pressed.
2. The green and red LEDs will be lit and the display will show **03**. This is the number of Editor keys that may be selected. If you want to change the number of Editor keys then press the grey button to cycle through **01,02,03**.
3. Press the blue button to confirm the number of Editors. The display will clear.

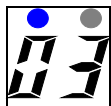

### 10.2 Adding the Editor Keys

The first 1,2 or 3 keys to be added will be Editor keys. These keys will allow access as well as allowing changes to be made to the system.

1. Present the first Editor Key to the front panel reader.
2. The display will briefly show the green LED. and the number **01**. Both dots will be lit indicating the key has access to both doors.  
The display will clear except for 2 dots and the green LED.
3. You may now present another key, which will become key 2. The display will briefly display **02** and return to the green LED. and two dots.
4. You can change the access of the Editor Keys (except number 1) - see *Adding Keys* for details.
5. To finish adding the Editor Keys present the *first* key again. The display will clear.

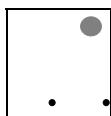

At this point you may continue adding keys as described in *Adding Keys*.

### 10.3 Setting the Lock Time

Each of the two lock relays can be set to operate the lock for between 1 and 48 seconds. Each may also be set to open or close when operated, allowing the use of fail-safe (power to lock) or fail-secure (power to unlock) locks.

1. Present an Editor key to the controller reader.
2. The Editor Key number will appear - **01** in this example.
  - To set the lock release time for door 1 press the blue button.
  - To set the lock release time for door 2 press the grey button.
3. The display will show the number of seconds currently set.
  - The red LED. will flash for lock 1.
  - The green LED. will flash for lock 2.
4. Select a time by pressing:
  - the grey button to increment the right digit.
  - the blue button to increment the left digit.

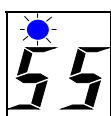
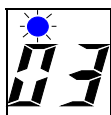
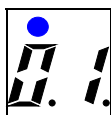

**Add 50 to the lock release time for the relay to be normally closed (fail-safe).**

The example shows a *fail-safe* lock set to 5 seconds lock release time.

5. Present the Editor key again to clear the display.

## 10.4 Replacing a Lost Editor Key 1

All Editor Keys, including number 1, can be deleted and a new key added in their place. However if all the Editor Keys are lost then the first key can be reinstalled using the following procedure:



1. Remove power from the Easikey.
2. Re-apply power with the **blue button only** pressed down.
3. The display will show **01** with the green LED. lit.
4. Present a new key to the controller reader.
5. The display will flash briefly before it clears

The key presented is now Editor Key 1.

## 11. Set-Reset Latch

A special facility is available **on lock 1 only** that allows the lock relay to be set when a valid key is presented, and reset when a valid key is presented again. This allows the reader to be used like a light switch to operate another system.

To use this facility you should set the lock release time of door 1 to **99** seconds.

### Note

When this facility is used the Request to Exit facility for door 1 will no longer be available.

## 12. Database Copy







This facility allows the contents of one Easikey's memory to be copied to another Easikey. The receiving Easikey will have the contents of its memory **completely overwritten** by the contents of the sending Easikey.

To perform this operation you need to connect reader terminal 2 of each Easikey with the following cable:

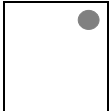
Use 0.22mm<sup>2</sup> reader cable, distance less than 10m.

Sending Controller		Receiving Controller
-V2	————	-V2
S2	————	A2
A2	————	S2
+V2	————	+V2

Only one Easikey needs to be powered.

Sending Controller		Receiving Controller
	Remove power from both the Easikeys.	
	Connect reader terminal 2 of both Easikeys with the cable shown above.	
	Power up one Easikey.	
	Present an Editor Key to the sending controller.	
	The Editor Key number will appear.	
	Press both buttons on the <b>sending</b> controller.	
	The display will blank and the green LED will be lit on the sending controller. The receiving controller will show 00 plus the red LED.	
	Press the blue button on the sending controller. Both displays will now count down from 10 to 01 with the LEDs flashing.	
	When the copy is finished the LEDs will stop flashing and a check number will be displayed. This should be the same on both controllers. If not, then repeat the operation.	

## 13. Dual Controller Option

It is possible to double the number of keyholders by connecting a reader to the same channel on *two* Easikey Controllers. If a key is found in either of the Controllers then the lock relay will operate. The diagrams below show two controllers controlling one Lock 1. To control Lock 2, connect a single reader to channel 2 of both controllers, and the lock through terminals L3 and L4 of each controller. Note that power is supplied to both Easikey controllers.

### 13.1 Reader Wiring

Notice that the reader wiring shown below includes a diode, (1N4001, not supplied) at each A1 (or A2) terminal. This is essential to provide correct operation of the reader LED.

The Request to Exit switch can be fitted to either controller - it is shown fitted to the second controller.

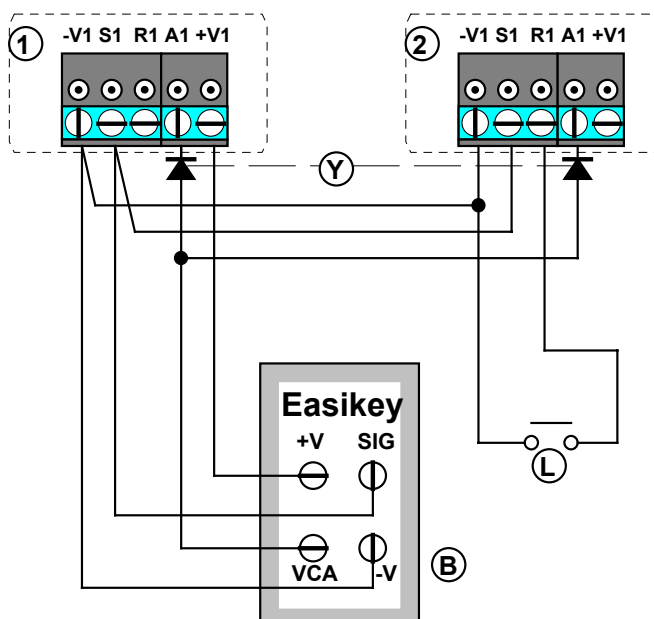

Reader Wiring for Dual Controller Operation

1	Easikey Controller 1		
2	Easikey Controller 2		
L	Request to Exit	B	Easikey Reader
Y	Diodes, 1N4001		

### 13.2 Lock Wiring

Two different lock wiring configurations are required for Fail Secure and Fail-Safe locks. Fail Secure locks are wired so that the relays are in **parallel**, that is whichever relay closes then power will be applied. Fail Safe locks are wired with the relays in **series**, so whenever one relay opens then power will be removed.



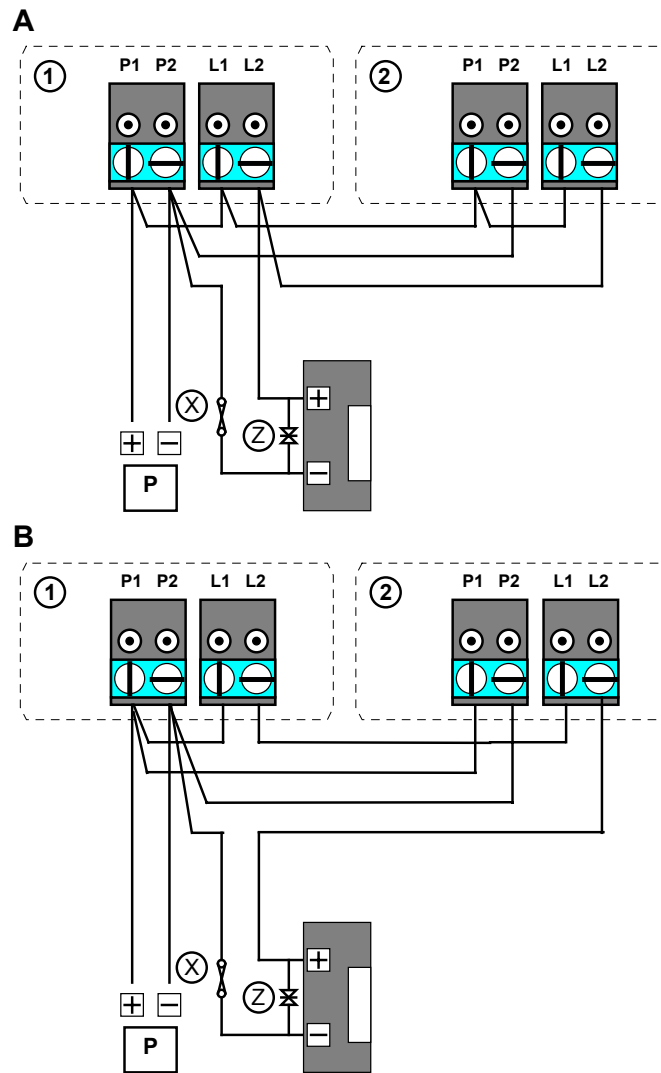

**Power and Lock Wiring for Dual Controller Operation**

- |          |                                             |
|----------|---------------------------------------------|
| <b>A</b> | Using Fail Secure Locks, Relays in Parallel |
| <b>B</b> | Using Fail Safe Locks, Relays in Series     |
| <b>1</b> | Easikey Controller 1                        |
| <b>2</b> | Easikey Controller 2                        |
| <b>P</b> | Power Supply                                |
| <b>X</b> | Fuse                                        |
| <b>Z</b> | MOV                                         |

### 13.3 Programming

Both Easikeys should be installed and initialised as described in this manual. However, please note the following:

- You should add the same Editor keys to each Easikey.
- Ensure that the Lock Release Times for each lock are programmed in exactly the same way on each controller.
- Note to which controller each key is added. If you need to delete a key then you must know to which controller it was added.

## 14. Easikey System Troubleshooting

Problem	Possible Cause	Check
Easikey Controller not Working	No Power	Check AC (mains) power supply and fuse. Check voltage at P1, P2 terminals, should be 10-16VDC or 10-12VAC.
	Fuse Blown	Check controller Fuse (1 amp)
Easikey controller OK, but neither reader operates.	No power at readers	Check power at reader, should be 9-16VDC.
	Reader wiring incorrect	Check wiring
	Lock Release Times set to 0	Change Lock Release Time to between 1 and 48 seconds.
One reader OK, but other is not.	Key not added	Add key to system
	No power at reader	Check power at reader, should be 9-16VDC.
	Reader wiring incorrect	Check wiring
Display 'counts' from 0-99	Lock Release Time set to 0	Change Lock Release Time to between 1 and 48 seconds.
	Key does not have access	Check key has access through both doors.
	Switches incorrectly set.	Switch all switches OFF, towards fuse.
System fails when a lock operates	Power supply overload	Power supply is not capable of supplying enough power to operate lock
		Lock is faulty and drawing too much current from power supply.
A key has stopped working	Faulty reader	If the reader is faulty then other keys will also fail to work - check the reader.
	Faulty key	Other keys will work without problem - replace the key.
	Incorrect programming	Check that the key exists in the controller, and it has been given correct access

## 15. Other Easikey Products

The following items are available for use with the Easikey 2-door Access Control System:

<b>Part No.</b>	<b>Description</b>	<b>Notes</b>
21275	Boxed Easikey	Complete with Easikey Controller 3Amp psu and wiring.
20377-Black 20387-White	Easikey Mullion Reader	For internal use.
20378-Steel 20388-Brass	Easikey Vandal Resistant Reader	For external use or where resistance to abuse is required. Supplied with 4 Vandal Resistant Screws (requires 1950 Screwdriver below)
20421	Easikey Panel Mount Reader	For fitting in steel panels, e.g. as part of a door entry system.
925	Request to Exit Switch	Large push switch for mounting on single-gang back box.
980	Battery	12v 6Ah
590-594	Coloured pegs: Red, Yellow, Blue, Green, White	For fitting into PAC keys.
1950	Screwdriver	For Vandal Resistant Screws used on Vandal Resistant Reader

<b>Declaration of Conformity</b>			
Application of Council Directives	73/23/EEC		
Standard(s) to which conformity is declared	EN55022-B, EN55082-1. EN60950.		
Manufacturer's Name	PAC International Ltd.		
Manufacturer's Address	1 Park Gate Close, Bredbury, Stockport, U.K. SK6 2SZ.		
Type of Equipment	Access control systems		
Product Equipment	Easikey Series		
I, the undersigned, hereby declare that the equipment specified above conforms to the above directive(s) and standard(s).			
Signed	<i>Vanda Murray</i>	Date	1st September 1995
Full Name	Vanda Murray	Position	Chief Executive