

Easikey Readers

Mullion, Vandal Resistant and Panel Mount

17063 Ver 1.6 DRAFT B January 2003

<input type="checkbox"/> 20377 Mullion Reader-Black <input type="checkbox"/> 20387 Mullion Reader-White <input type="checkbox"/> 20378 Vandal Resistant Reader-Steel <input type="checkbox"/> 20388 Vandal Resistant Reader-Brass <input type="checkbox"/> 20421 Panel Mount Reader	CAUTION These readers are suitable for connection to Easikey and Easikey 1000 only . They should not be connected to any other type of equipment (e.g. PAC 2100/2200 series).
---	--

1. Introduction

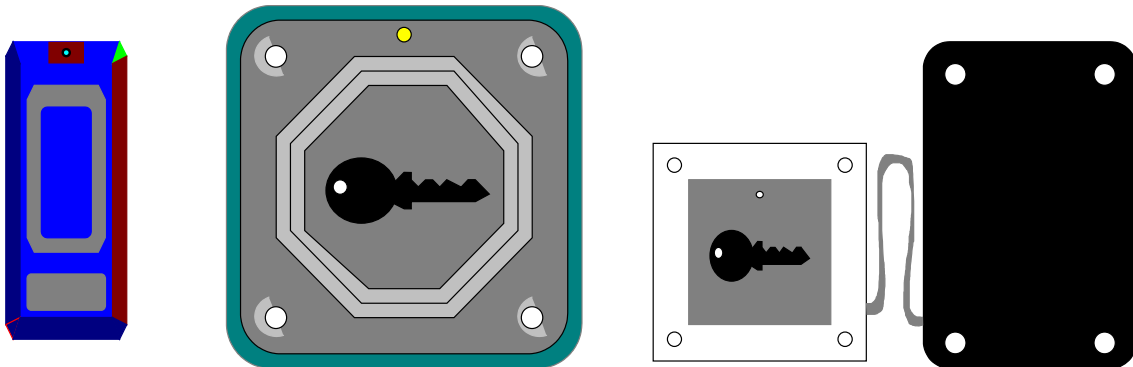

Mullion	Vandal Resistant *	Panel Mount *
Items Enclosed		
Mullion reader	Vandal resistant reader	Panel mount reader and head
4 terminal screws	4 terminal screws	4 terminal screws
MOV	MOV	MOV
Mounting backplate	4 x 1 1/4" No. 8 VR screws	Lexan window and backplate
Label	A special screwdriver (available separately) is required for the Vandal Resistant (VR) screws.	
2 x 1" No.6 self-tapping screws		

Note

The readers come with a 6-wire suppression lead that should be installed as described in this datasheet. This cable must be installed to comply with CE regulations.

Dimensions

H x W x D mm	H x W x D mm	H x W x D mm
83 x 3.38 x 12	100 x 100 x 12	92 x 62 x 15 Reader 60 x 60 x 12 Head

Maximum Reading Range

25mm	8mm	8mm
------	-----	-----

Specification for all readers

Operating Temperature:	-40C to +50C
Current:	90mA (maximum)
Supply Voltage:	9-16v DC (supplied by the controller)
Cable Type:	4 or 6-conductor, multi-stranded, unshielded
Cable Distances:	Up to 100m from controller using 7/0.2 (0.22mm ²)

RFID Devices

As similar RFID technology is now widely used in a number of other industries, for example automotive immobilisers, it is possible that interaction between your access control ID and other devices may cause one or the other to function incorrectly. Should you suspect that you have experienced such a problem the solution is to separate your access control ID from other RFID devices.

FCC Notice

This device complies with part 15 of the FCC rules. Operation is subject to the following two conditions (1) this device may not cause harmful interference, and (2) this device must accept any interference received, including interference that may cause undesired operation.

Mullion Reader	FCC ID OQL-EK-MUL
Vandal Resistant Reader	FCC ID OQL-EK-VN
Panel Mount Reader	FCC ID OQL-EK-PNL

Changes or modifications not expressly approved by the party responsible for compliance could void the user's authority to operate the equipment.

2. Installation

2.1 Mullion Reader - Installation

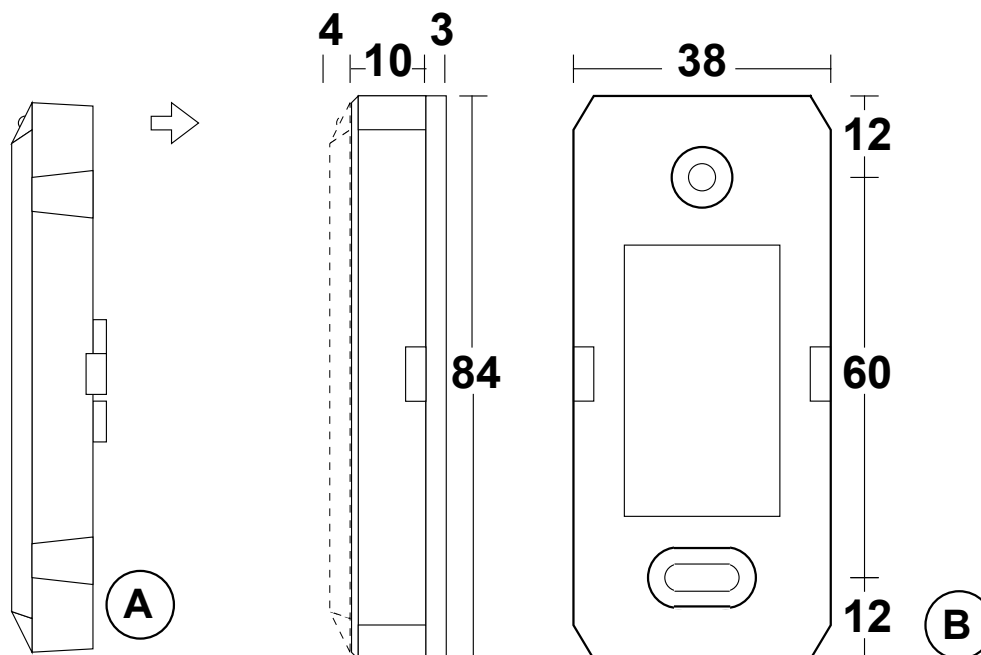

This reader comes in two parts, the reader itself (A) with 4 terminals and the backplate (B). The backplate has a 3mm rubber spacer at the rear.

2.1.1 Fixing the Reader

1. The cable from the controller should be routed through the aperture in the backplate. Leave enough cable exposed to allow easy wiring of the reader (at least 20mm).

Note

There is limited room between the reader and backplate. You should ensure there is a void large enough behind the backplate to accommodate any excess on the suppression cable.

2. Fix the backplate to a flat surface using the No.6 screws provided - or a fixing suitable for the material to which the reader is being mounted. The two holes are 60mm apart. Use the top (round) hole first, and the lower (oval) hole to ensure the reader is straight.
3. Ensure that the reader cable is **not** connected to the controller. Wire the reader to the cable as described in the documentation supplied with the controller.
4. Push the reader, with the green LED to the top, onto the backplate, the fixing tabs on each side should snap into place.
5. Place label on front of reader.

2.2 Removing the Reader

The reader can be removed from the backplate by placing a small flat-bladed screwdriver into the apertures on each side of the backplate. Take care not to damage the reader or backplate.

3. Vandal Resistant Reader - Installation

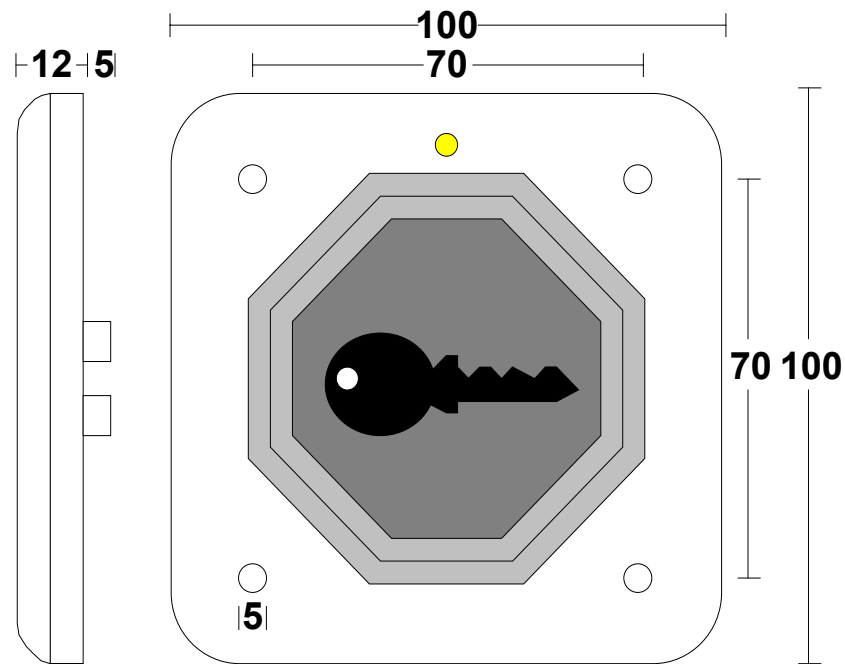

This reader should be mounted using the Vandal Resistant screws provided.

Note

A special screwdriver (not supplied) is required to use these screws.

3.1 Fixing the Reader

The cable from the controller should come to the rear of the reader. Leave enough cable exposed to allow easy wiring of the reader (at least 20mm).

Note

The terminals protrude 5mm from the rear of the reader. You should ensure there is a void large enough (about 40mm square and 20mm deep) behind the reader to accommodate the terminals and excess suppression cable.

1. Ensure that the reader cable is **not** connected to the controller. Wire the reader to the cable as described in the documentation supplied with the controller.
2. Apply a silicone sealant to the terminals to protect against moisture if the reader is mounted outside.
3. Fix the reader to as flat and even a surface as possible. This will reduce the possibility of it being levered from the wall. Either use the Vandal Resistant screws provided, or other suitable fixings. The LED should be to the top.

4. Panel Mount Reader - Installation

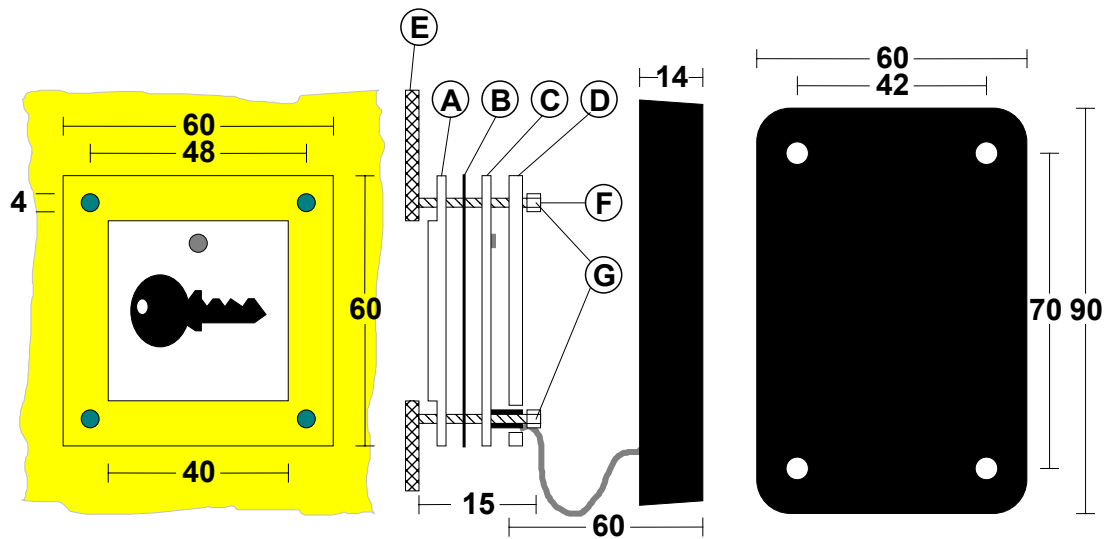

This reader is designed to be mounted in a steel panel (E), such as used in a door-entry system. There are two main units; the main module, a black rectangular unit, connected by a fixed length of cable to a reading head. The cable between the two parts is fixed, 60mm long and **should not be cut, extended or shortened**.

4.1 Panel Aperture

The reading head is designed to fit a 40mm square hole. Holes on the reading head, 48mm between centres, accept M3 fixing studs (F). The studs should be at least 15mm long. The front cover (A) protrudes 2.5mm through the aperture.

4.2 Locating the Main Module

Mount the module in a convenient place behind the panel. The holes in each corner will accept No. 6 screws. Ensure that the module is close enough to the reader head to allow the panel to be removed without straining the cable. Wire the Module to the cable as described in the documentation supplied with the controller.

4.3 Fixing the Reading Head

There are 4 components to the reading head:

1. Remove the protective film from the front lexan window (A). Mount on the studs so that the centre fits through the aperture, with the shallow slot to the bottom.
2. Remove the backing from the label, and fit to the circuit board (C), the clear hole should align with the green LED.
3. Place the circuit board (C) and label over the studs against the window with the cable facing away from the aperture.
4. Fit the rear lexan cover (D) and clamp using screws suitable for the studs (G).

5. Reader Wiring

5.1 General Tips

- The cable distance from controller to reader should never exceed 100m.
- If using a Request to Exit switch, ensure that the wiring is not accessible if the reader is removed.
- Ensure that the LED is always visible to the keyholder.

Note

The wiring and location of readers is fully described in the documentation supplied with the controller. All the readers described on this sheet have identical terminals. It is strongly recommended that a 100mA in-line fuse is fitted across the reader supply.

5.2 Connecting the Suppression Cable

One end of the 6-core suppression cable is connected to the reader and the other is connected to the cable connected to the reader channel on the controller. The suppression cable comes with four spade crimps at one end for easy connection to the PEMs on the reader. Crimp wire joints are provided for connection to the reader cable from the controller.

The following table details suppression cable connections to both the reader and to the reader cable from the controller.

Note

Standard 6-core alarm cable is usually used for the Controller Reader cable. Care must be taken if this is not the case or if a different colour convention is used than that given in the table.

Suppression Cable		Controller Reader Cable		
Colour	Reader Connection	Colour	Easikey	Easikey 1000
Black	-V	Black	-V1/-V2	VSIG
Green	SIG	Green	S1/S2	
Blue	-V	Blue	n/c	DC
Brown	-V	Yellow	R1/R2	RTE
White	VCA	White	A1/A2	VCA
Red	+V	Red	+V1/+V2	V+

The following diagram is how we recommend that the cable is wired.

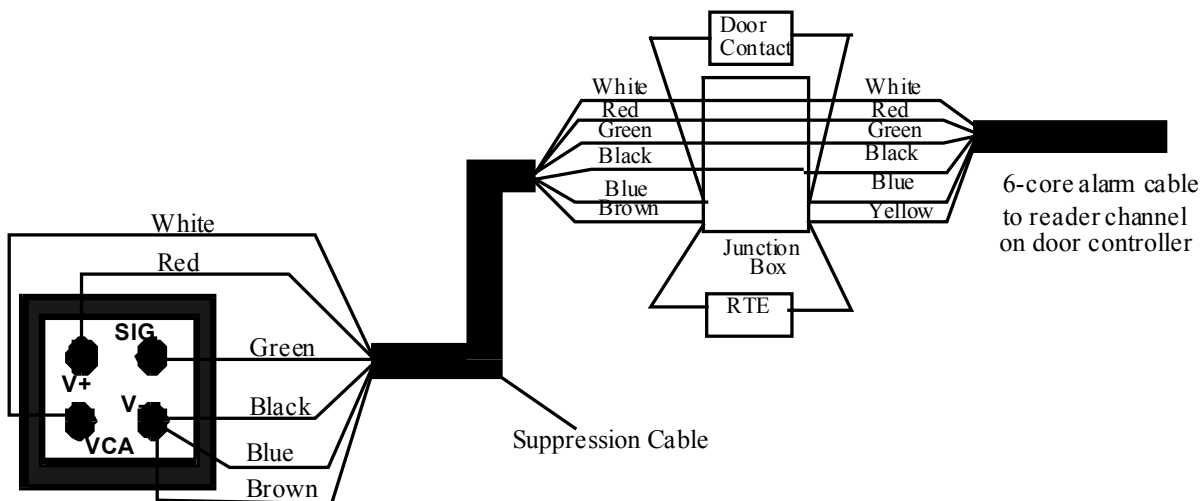

Notes

1. The ends of any cores not used on the suppression cable can be snipped off.
2. If the controller is an Easikey then there is no Door Contact option available and the Brown core on the suppression cable is not used.

5.3 MOV - Lock Suppression

A metal-oxide-varistor (MOV) is provided with each reader. This device prevents back e.m.f. ('spikes') being returned from the electric lock to the controller. This can cause severe damage over a period of time, and erratic operation of the system if not controlled.

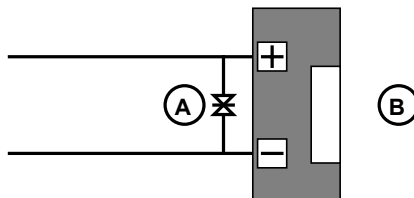

The MOV (A) should be fitted across the power terminals of the lock (B). It can be fitted across the relay contacts on the controller, but this will be less effective.

Important Notice

If the reader is installed externally, then the terminals on the rear of the reader MUST be sealed with a silicone compound to prevent corrosion.

Declaration of Conformity	
Application of Council Directives	73/23/EEC
Standard(s) to which conformity is declared	ETS 300.683
Manufacturer's Name	PAC INTERNATIONAL LTD
Manufacturer's Address	1 Park Gate Close, Bredbury, Stockport, U.K. SK6 2SZ
Type of Equipment	Access Control Systems
Product Equipment	Easikey Reader Range
I, the undersigned, hereby declare that the equipment specified above conforms to the above directive(s) and standard(s).	
Signed	<i>Vanda Murray</i>
Date	20 th November 1995
Full Name	Vanda Murray
Position	Managing Director