

Panasonic®

DVD/VCR Home Theater Sound System

Operating Instructions

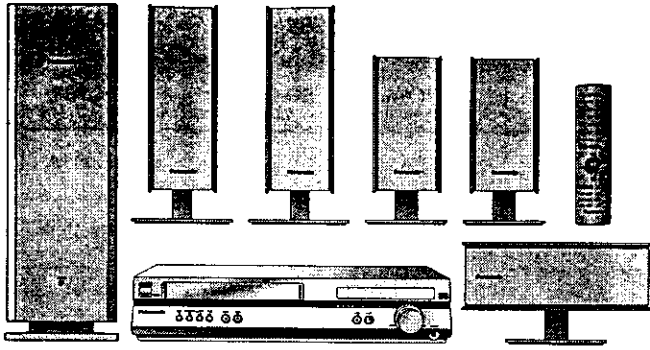

The illustration shows SC-HT810V.

Model No. **SC-HT790V**
SC-HT800V
SC-HT810V

INTRO

SETUP

DVD

VCR

RADIO
&
OTHERS

INFO

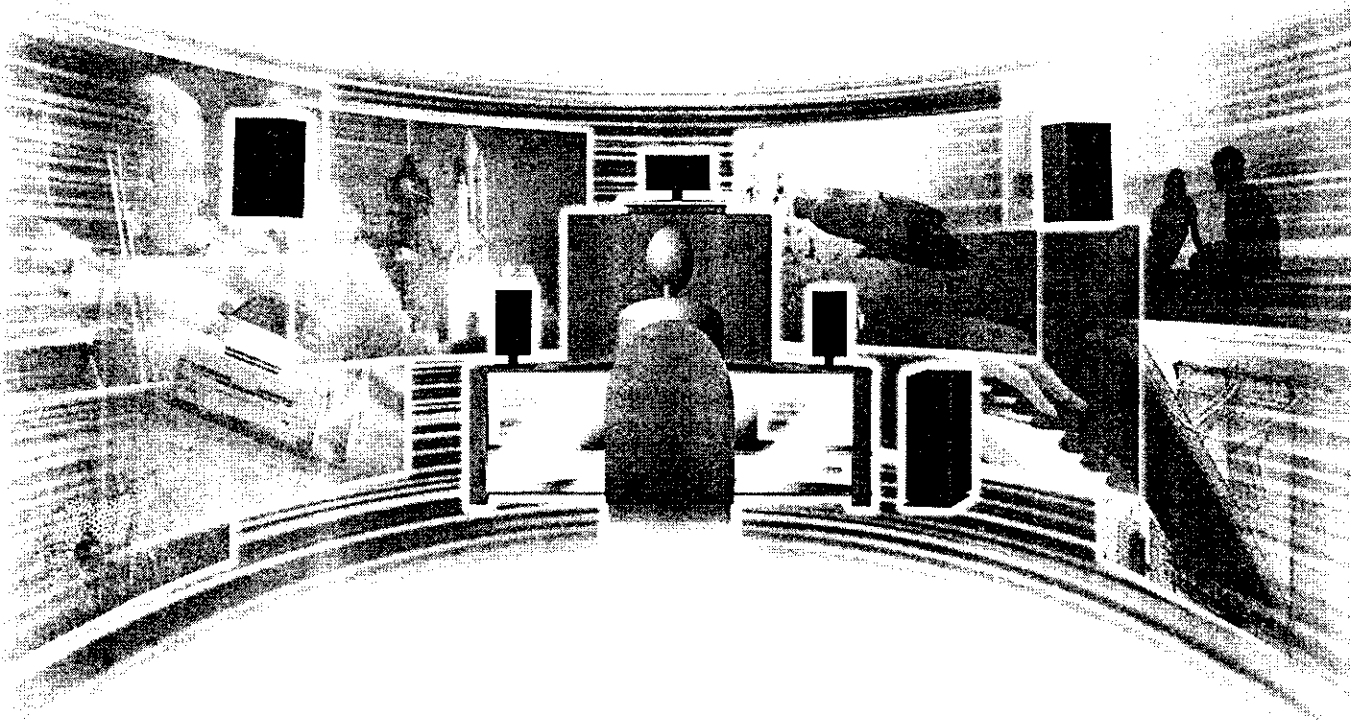

Before connecting, operating or adjusting this product,
please read these instructions completely.
Please keep this manual for future reference.

DVD
AUDIO / VIDEO

COMPACT
disc
DIGITAL VIDEO

VHS

SUPER DRIVE Omnicision

For U.S.A.



As an ENERGY STAR® Partner, Panasonic has
determined that this product meets the ENERGY
STAR® guidelines for energy efficiency.

Region number supported by this unit

Region numbers are allocated to DVD players and software
according to where they are sold.

- The region number of this unit is "1".
- This unit will play DVD-Video marked with labels containing "1"
or "ALL".

Example:



The warranty for the U.S.A. is on page 62.

P PP

RQT6951-3P

Dear customer

Thank you for purchasing this product.
For optimum performance and safety, please read these instructions carefully.

• These operating instructions are applicable to models SC-HT790V, SC-HT800V and SC-HT810V.
• Operations in these instructions are described mainly with the remote control, but you can do the operations on the main unit if the controls are the same.









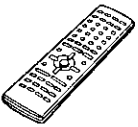

System	SC-HT790V	SC-HT800V	SC-HT810V
Main unit	SA-HT790V	SA-HT800V	SA-HT810V
Front speakers	SB-FS803	SB-FS803	SB-FS700
Center speaker	SB-PC803	SB-PC803	SB-PC700
Surround speakers	SB-FS803	SB-FS803	SB-FS801A
Active subwoofer	SB-WA312	SB-WA310	SB-WA330

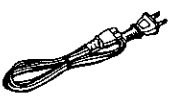

Accessories

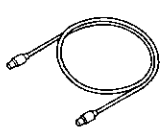
 Please check and identify the supplied accessories. Use numbers indicated in parentheses when asking for replacement parts.

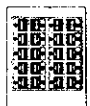
(Only for U.S.A.)
To order accessories contact 1-800-332-5368 or the website (<http://www.panasonic.com>).
(Only for Canada)
To order accessories, call the dealer from whom you have made your purchase.

- 1 Remote control (EUR7623X50) 
- 2 Batteries for remote control 
- 2 AC power supply cord (RJA0065-1D) 
- 1 AM loop antenna (N1DAAAA00002) 
- 1 FM indoor antenna (RSA0007-J) 
- 1 Video cable (RJL1P016B15A) 
- 1 75 Ω coaxial cable (VJA1125) 
- 1 System cable (K1HA25SHA0001) 
- 5 Speaker cables (RFA2163-J) 3×4-m (13-foot) cables 2×10-m (33-foot) cables 
- 1 Sheet of speaker-cable stickers 
- 1 Antenna plug (K2RC021B0001) 

The remote control

Remote control 

Batteries 

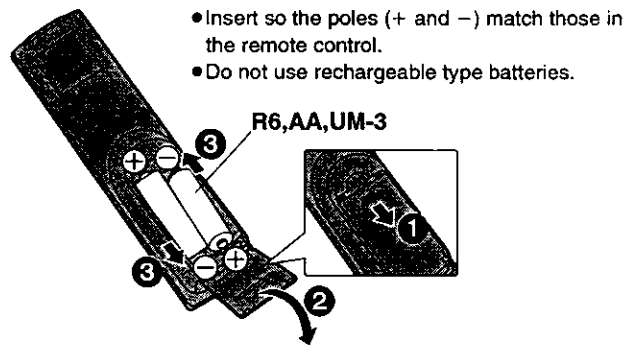

- Insert so the poles (+ and -) match those in the remote control.
- Do not use rechargeable type batteries.

Do not;

- mix old and new batteries.
 - use different types at the same time.
 - heat or expose to flame.
 - take apart or short circuit.
 - attempt to recharge alkaline or manganese batteries.
 - use batteries if the covering has been peeled off.
- Mishandling of batteries can cause electrolyte leakage which can damage items the fluid contacts and may cause a fire.

Remove if the remote control is not going to be used for a long period of time. Store in a cool, dark place.

Use

Aim at the sensor (⇒ page 9), avoiding obstacles, at a maximum range of 7 m (23 feet) directly in front of the unit.

User memo:

DATE OF PURCHASE	_____
DEALER NAME	_____
DEALER ADDRESS	_____
TELEPHONE NUMBER	_____

The model number and serial number of this product can be found on either the back or the bottom of the unit. Please note them in the space provided below and keep for future reference.	
MODEL NUMBER	_____
SERIAL NUMBER	_____

Note

The included AC power supply cord is for use with this unit only. Do not use it with other equipment.



Accessories 2
 The remote control 2
IMPORTANT SAFETY INSTRUCTIONS 5
Tape information 5
Disc information 6

Control reference guide 7
 Remote control—common buttons 7
 Remote control—DVD operation 7
 Remote control—VCR operation 8
 Remote control—TUNER operation 8
 Main unit and subwoofer 9
 Main unit display 9



Simple setup
STEP1 Locating 10
STEP2 Speakers 11
STEP3 Television 12
 Basic connection 12
 For better video from DVD 13

STEP4 Connecting the subwoofer, antennas, and AC power supply cords 14
STEP5 Plug-in Auto Tuning 15
STEP6 Operating the television 16
STEP7 DVD QUICK SETUP 17



Basic play 18
 Position Memory function 19
Convenient functions 20
 Replaying a scene—QUICK REPLAY 20
 Starting play from a selected item 20
 Selecting groups to play 20
 Rotating pictures 20
 Selecting still pictures—Page Skip 20
 Repeat play 21
 A-B repeat play 21
 Marking places to play again 21
WMA/MP3, CD text and JPEG navigation menus 22
 Playing HighMAT discs 23
Playing the programs or play lists on DVD-RAM 24
 Selecting a program to play—DIRECT NAVIGATOR 24
 Playing a play list 24

Changing play sequence 25
 All group play 25
 Program play 25
 Random play 25
Increasing your enjoyment of movies and music 26
 Soundtracks 26
 Subtitles 26
 Variable Zoom function 27
 Double re-master—Enjoying more natural sound 27
Using On-Screen Menu Icons 28
 Common procedures 28
 Progress indicator 28
 Disc information 29
 Unit information 29
Changing settings 31
 Common procedures 32
 Entering a password (Ratings) 33
 Changing the delay time (Speaker Setting) 33



Playback 34
 Picture mode—Changing picture quality 35
 Repeat play—play a program repeatedly 35
 Manual tracking 35
 Vertical locking adjustment 35
Manual recording 36
 Recording the television 36
 Using another source while recording 37
 Recording from other equipment 37
Timer recording 38

Finding programs with the Jet Navigator and VHS Index Search System (VISS) 40
 Saving Jet Navigator data 40
 Using the Jet Navigator to find programs 40
 Finding programs—VHS Index Search System (VISS) 41
Changing settings 42
 LANGUAGE 42
 CLOCK SET 42
 CHANNEL SET 43
 OPTION 44
 On-screen display 45
 Changing audio 45



The radio 46
 Manual tuning 46
 Preset tuning 46
 Optional FM antenna connection 47
Other convenient features 48
 The sleep timer 48
 Muting the volume 48
 Using headphones 48

Sound 49
 Custom Sound Memory—Store the sound settings 49
 Dolby Digital and DTS 50
 Dolby Pro Logic 50
 Super Surround 50
 Sound Field Control 50
 Center Focus 51
 Seat position 51
 Adjusting the bass 51
 Speaker level adjustments 51



Other speaker setup options 52
 Attaching to a wall 52
 Fitting speaker stands (optional) 52
Optional connections 53
 Listening to an external source/
 Recording to other equipment 53
 Connecting a cable TV box/satellite receiver 54
 Other antenna connections to the unit 55
 Other antenna connections from the unit to the television 55

Troubleshooting guide 56
Glossary 59
Maintenance 59
Specifications 60
Limited Warranty (U.S.A.) 62
Product Service 63
Index Back cover



CAUTION!

DO NOT INSTALL OR PLACE THIS UNIT IN A BOOKCASE, BUILT-IN CABINET OR IN ANOTHER CONFINED SPACE. ENSURE THE UNIT IS WELL VENTILATED. TO PREVENT RISK OF ELECTRIC SHOCK OR FIRE HAZARD DUE TO OVERHEATING, ENSURE THAT CURTAINS AND ANY OTHER MATERIALS DO NOT OBSTRUCT THE VENTILATION VENTS.

CAUTION:

TO PREVENT ELECTRIC SHOCK MATCH WIDE BLADE OF PLUG TO WIDE SLOT, FULLY INSERT.

WARNING:

TO REDUCE THE RISK OF FIRE, ELECTRIC SHOCK OR PRODUCT DAMAGE, DO NOT EXPOSE THIS APPARATUS TO RAIN, MOISTURE, DRIPPING OR SPLASHING AND THAT NO OBJECTS FILLED WITH LIQUIDS, SUCH AS VASES, SHALL BE PLACED ON THE APPARATUS.

CAUTION!

THIS PRODUCT UTILIZES A LASER. USE OF CONTROLS OR ADJUSTMENTS OR PERFORMANCE OF PROCEDURES OTHER THAN THOSE SPECIFIED HEREIN MAY RESULT IN HAZARDOUS RADIATION EXPOSURE. DO NOT OPEN COVERS AND DO NOT REPAIR YOURSELF. REFER SERVICING TO QUALIFIED PERSONNEL.

Note to CATV system installer:

This reminder is provided to call the CATV system installer's attention to Article 820-40 of the NEC which provides guidelines for proper grounding and, in particular, specifies that the cable ground shall be connected to the grounding system of the building, as close to the point of cable entry as practical.

CAUTION	- LASER RADIATION WHEN OPEN DO NOT STARE INTO BEAM FDA 21 CFR / Class II
CAUTION	- VISIBLE AND INVISIBLE LASER RADIATION WHEN OPEN AVOID EXPOSURE TO BEAM IEC60825-1 / Class 3b
WARNING	- SYNLIG OCH OSYNLIG LASERSTRÅLNING NÄR DENNA DEL ÄR ÖPPNAD. BETRÄKTA EJ STRÅLEN
ADVARSEL	- SYNLIG OG USYNLIG LASERSTRÅLING VED ÅBNING. UNDGÅ UDSÆTTELSE FOR STRÅLING
ADVARSEL	- SYNLIG OG USYNLIG LASERSTRÅLING NÄR DEKSEL ÄR ÖPPNAD. BETRÄKTA EJ STRÅLEN
VARO!	- HUHTAESSA OLET ALTIIDIN NÄKYVÄÄ JA HÄNRYÖNTÄ LASERSÄTELYLLÄ. ÄLÄ KATSO SÄTEESEEN.
VORSICHT	- SICHTBARE UND UNSICHTBARE LASERSTRÄHLUNG, WENN ABDECKUNG GEÖFFNET. NICHT DEM STRAHL AUSSETZEN
ATTENTION	- RAYONNEMENT LASER VISIBLE ET INVISIBLE EN CAS D'OUVERTURE. EXPOSITION CONSENUESE AU FAISCEAU
注意	- 本产品内含有不可见激光。请勿直视激光束。
注意	- この製品を開くと有害なレーザー光線が放射されます。目を直視しないでください。RDU50254

(Inside of product)

THE FOLLOWING APPLIES ONLY IN THE U.S.A.:

CAUTION:

This equipment has been tested and found to comply with the limits for a Class B digital device, pursuant to Part 15 of the FCC Rules.

These limits are designed to provide reasonable protection against harmful interference in a residential installation. This equipment generates, uses and can radiate radio frequency energy and, if not installed and used in accordance with the instructions, may cause harmful interference to radio communications. However, there is no guarantee that interference will not occur in a particular installation. If this equipment does cause harmful interference to radio or television reception, which can be determined by turning the equipment off and on, the user is encouraged to try to correct the interference by one or more of the following measures:

- Reorient or relocate the receiving antenna.
- Increase the separation between the equipment and receiver.
- Connect the equipment into an outlet on a circuit different from that to which the receiver is connected.
- Consult the dealer or an experienced radio/TV technician for help.

Any unauthorized changes or modifications to this equipment would void the user's authority to operate this device.

This device complies with Part 15 of the FCC Rules. Operation is subject to the following two conditions: (1) This device may not cause harmful interference, and (2) this device must accept any interference received, including interference that may cause undesired operation.



CAUTION

RISK OF ELECTRIC SHOCK
DO NOT OPEN



CAUTION: TO REDUCE THE RISK OF ELECTRIC SHOCK, DO NOT REMOVE SCREWS. NO USER-SERVICEABLE PARTS INSIDE. REFER SERVICING TO QUALIFIED SERVICE PERSONNEL.

The lightning flash with arrowhead symbol, within an equilateral triangle, is intended to alert the user to the presence of uninsulated "dangerous voltage" within the product's enclosure that may be of sufficient magnitude to constitute a risk of electric shock to persons.



The exclamation point within an equilateral triangle is intended to alert the user to the presence of important operating and maintenance (servicing) instructions in the literature accompanying the appliance.



Avoid use or placing highly magnetic devices (Speakers etc.) or devices that emit strong electro-magnetic waves (mobile telephones etc.) near the main unit.

- The above may result in problems with audio and video, and recorded content may be lost.
- Be extra cautious when you are using a plasma television, keeping these devices as far away as possible.

Stacking

Place the unit in a horizontal position, and do not place anything heavy on it.

Before moving the unit, ensure the disc tray and video cassette slot is empty. Failure to do so will risk severely damaging the disc, video cassette tape and the unit.

- Operating while there is condensation in the unit or on the cassette tape may cause the tape to catch upon the cylinder resulting in the tape being cut, or not being able to remove the cassette tape from the unit. The unit also may not work properly if the unit's cylinder or heads have been damaged.
- Wait 1-2 hours for condensation to evaporate (do not operate the unit during this time).

IMPORTANT SAFETY INSTRUCTIONS

Read these operating instructions carefully before using the unit. Follow the safety instructions on the unit and the applicable safety instructions listed below. Keep these operating instructions handy for future reference.

- 1) Read these instructions.
- 2) Keep these instructions.
- 3) Heed all warnings.
- 4) Follow all instructions.
- 5) Do not use this apparatus near water.
- 6) Clean only with dry cloth.
- 7) Do not block any ventilation openings. Install in accordance with the manufacturer's instructions.
- 8) Do not install near any heat sources such as radiators, heat registers, stoves, or other apparatus (including amplifiers) that produce heat.
- 9) Do not defeat the safety purpose of the polarized or grounding-type plug. A polarized plug has two blades with one wider than the other. A grounding-type plug has two blades and a third grounding prong. The wide blade or the third prong are provided for your safety. If the provided plug does not fit into your outlet, consult an electrician for replacement of the obsolete outlet.
- 10) Protect the power cord from being walked on or pinched particularly at plugs, convenience receptacles, and the point where they exit from the apparatus.
- 11) Only use attachments/accessories specified by the manufacturer.
- 12) Use only with the cart, stand, tripod, bracket, or table specified by the manufacturer, or sold with the apparatus. When a cart is used, use caution when moving the cart/apparatus combination to avoid injury from tip-over.
- 13) Unplug this apparatus during lightning storms or when unused for long periods of time.
- 14) Refer all servicing to qualified service personnel. Servicing is required when the apparatus has been damaged in any way, such as power-supply cord or plug is damaged, liquid has been spilled or objects have fallen into the apparatus, the apparatus has been exposed to rain or moisture, does not operate normally, or has been dropped.



Tape Information

■ Tapes

- You can use tapes with the VHS and S-VHS marks, but this unit is unable to make full use of the characteristics of S-VHS tapes.
- Break out the tape's tab to prevent accidental erasure. Cover the hole with a double layer of adhesive tape when you want to use the tape for recording again.

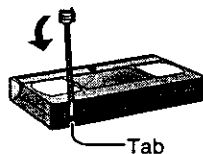

■ S-VHS Quasi Playback (SQPB)

You can play tapes recorded with the S-VHS system, however some noise may occur with some types and this unit cannot take advantage of S-VHS's high resolution. This VCR cannot make S-VHS recordings.





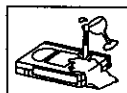

■ Tape care

Poor quality or damaged tapes can cause the heads to become dirty and malfunction. Store your tapes carefully and discard when they become dirty or damaged.

Never use tapes on which juice has been split or those that are extremely damaged since this will not only cause the heads to become dirty, but will also make the unit malfunction.



■ Discs that can be played

Disc type	Logo	Indication used in instructions
DVD-RAM		RAM Shown as "DVD-VR" on the display
DVD-Audio		DVD-A
DVD-Video		DVD-V
DVD-R		
Video CD		VCD
CD		CD Including CD text
CD-R/RW	—	WMA MP3 JPEG

- Use discs with the above logos and that conform to specifications. The unit cannot play other discs correctly.
- Do not use irregularly shaped discs (e.g. heart-shaped), as these can damage the unit.
- It may not be possible to play CD-R, CD-RW, DVD-R and DVD-RAM in all cases due to the type of disc or condition of the recording.

■ Discs that cannot be played

PAL discs (except DVD-Audio), DVD-ROM, CD-ROM, CDV, CD-G, +RW, DVD-RW, CVD, SVCD, SACD, Divx Video Discs, Photo CD, DVD-RAM that cannot be removed from their cartridge, and 2.6-GB and 5.2-GB DVD-RAM.

■ Disc structure

Disc structure and the labels given to the items on discs depend on the disc type.

- Track:** the smallest division on DVD-Audio, CDs and Video CDs, or a single WMA/MP3 file.
- Chapter:** the smallest division on DVD-Video.
- Group:** collections of tracks on DVD-Audio and equivalent to folders or albums on data discs.
- Title:** the largest division on DVD-Video, usually an entire movie.
- Program:** the division on DVD-RAM equivalent to a single recording.
- Picture:** a single JPEG file.
- Play list:** the largest grouping on a HighMAT disc, or a group of scenes on DVD-RAM.
- Scene:** DVD-RAM program sections specified and grouped into play lists on a DVD video recorder.
- Content:** covers tracks and pictures on HighMAT discs.

■ DVD-RAM discs

The DVD-RAM you can play on this unit are those recorded with DVD video recorders, DVD video cameras, personal computers, etc. using Version 1.1 of the Video Recording Format (a unified video recording standard).

- Remove discs from their cartridges before use and return them when you are finished, making sure that the labels of the disc and cartridge face the same way.
- Some parts of the disc, for example where one program ends and another begins, may not play smoothly.

■ DVD-R discs

Panasonic DVD-R recorded and finalized (a process that allows play on compatible equipment) on a Panasonic DVD video recorder or DVD video camera are played as DVD-Video on this unit.

■ CD-R and CD-RW discs

This unit can play CD-R/RW (audio recording disc) recorded with CD-DA, video CD, WMA, MP3, or JPEG. Close the session or finalize (a process that allows play on compatible equipment) after recording.

See page 23 for more information about WMA, MP3, and JPEG.

■ HighMAT discs

This unit is compatible with HighMAT discs containing WMA, MP3, and/or JPEG files.

■ Video systems

NTSC is used.

This unit converts still picture parts of PAL system DVD-Audio to NTSC for play. The picture is compressed to show it in its entirety, but this may cause it to be stretched vertically.

Playing DVDs and Video CDs

The producer of these discs can control how they are played so you may not always be able to control play as described in these operating instructions (for example if the play time is not displayed or if a Video CD has menus). Read the disc's instructions carefully.

■ To clean discs

DVD-Audio, DVD-Video, Video CD, CD

Wipe with a damp cloth and then wipe dry.

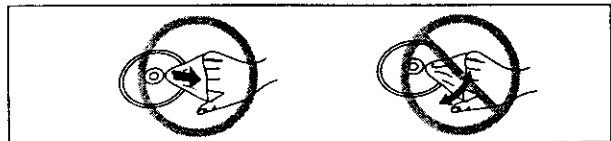

DVD-RAM, DVD-R

- Clean with an optional DVD-RAM/PD disc cleaner (LF-K200DCA1, where available).
- Never use cloths or cleaners for CDs etc.

■ Handling precautions

- Do not write on the label side with a ball-point pen or other writing instrument.
- Do not use record cleaning sprays, benzene, thinner, static electricity prevention liquids or any other solvent.
- Do not attach labels or stickers to discs. (Do not use discs with exposed adhesive from tape or left over peeled-off stickers.)
- Do not use scratch-proof protectors or covers.
- Do not use discs printed with label printers available on the market.

• If [SHIFT] appears after the button name the function will not work unless you use with [SHIFT] button. Make sure to press [SHIFT] and the button.

Remote control—common buttons

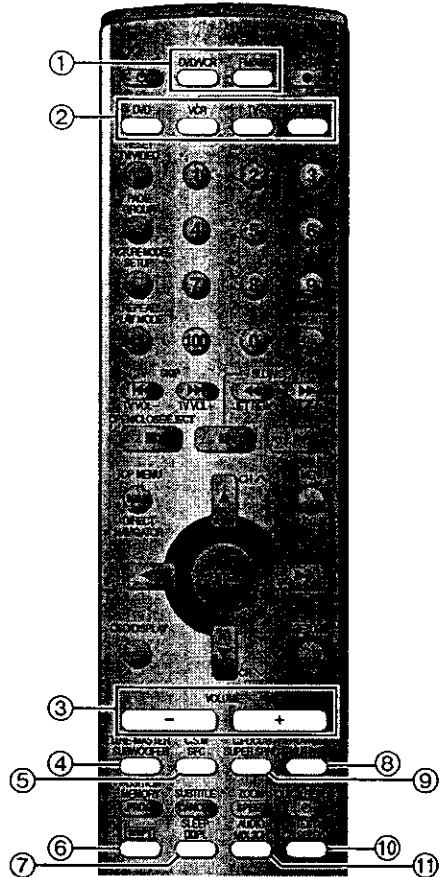

- ① **Main unit selector button**
DVD/VCR source button [DVD/VCR]
Switch the source on the main unit between DVD and VCR.
- Tuner/band button [FM/AM]**
Switch the source on the main unit to TUNER and change the band.
- ② **Remote control mode selector button**
[DVD] [VCR] [TV] [TUNER]
Changes the remote control mode. The button lights once pressed.
The selected mode is held in memory until you press another mode selector button.
The mode selector button lights each time you press an operational control button showing which mode is in use.
- ③ **Volume buttons [VOLUME - , +]** 18
Volume may be lower when playing DVD-Video than when playing other discs or during television broadcasts. Reduce the volume before playing other sources or returning to the television so volume doesn't increase suddenly.
- ④ **Bass adjust button [SUBWOOFER]** 51
- ⑤ **Sound field control button [SFC]** 50
- Custom sound memory button [C.S.M] [SHIFT]** 49
- ⑥ **Shift button [SHIFT]**
To use the functions labeled in orange, press the button while pressing [SHIFT].
- ⑦ **Dolby Pro Logic button [DOLBY]** 50
- Sleep timer button [SLEEP] [SHIFT]** 48
- ⑧ **Muting button [MUTING]** 48
- Seat position button [S.POSITION] [SHIFT]** 51
- ⑨ **Super surround button [SUPER SRND]** 50
- Center focus button [C.FOCUS] [SHIFT]** 51
- ⑩ **Speaker channel button [CH SELECT]** 51
- Test signal button [TEST] [SHIFT]** 51
- ⑪ **Down-mix button [MIX 2CH]** 50



Remote control—DVD operation

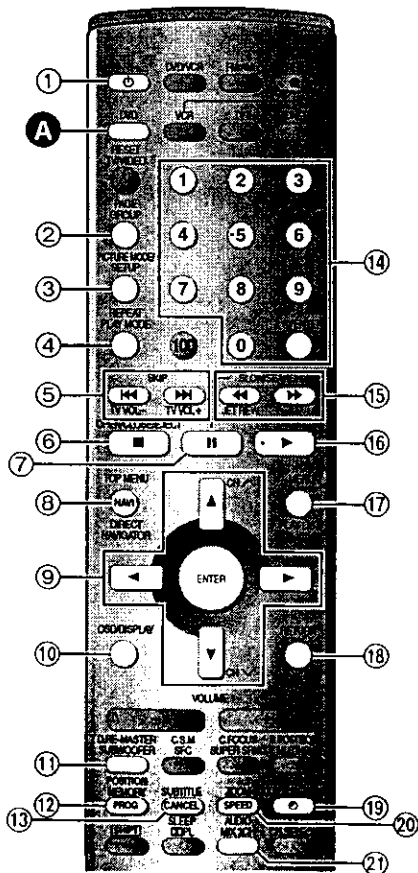

- A **DVD remote control mode button [DVD]** 17
Switch the remote control mode to DVD. Make sure you press before doing DVD operations. When in DVD mode, the [DVD] button lights each time you press one of the DVD operation buttons indicated below.
- ① **Power button [⏻]** 17
Press to switch the unit from on to standby mode or vice versa. In standby mode, the unit is still consuming a small amount of power.
- ② **Group button [GROUP]** 20
- Still picture select button [PAGE] [SHIFT]** 20
- ③ **DVD SETUP menu button [SETUP]** 17, 32
- ④ **Play mode button [PLAY MODE]** 25
- Repeat mode button [REPEAT] [SHIFT]** 21
- ⑤ **Skip buttons [⏮, ⏭] SKIP** 18
- ⑥ **Stop button [■]** 18
- Open/close button [OPEN/CLOSE/EJECT] [SHIFT]** 18
- ⑦ **Pause button [⏸]** 18
- ⑧ **Top menu button [TOP MENU]** 19
- Direct navigator button [DIRECT NAVIGATOR]** 24
- ⑨ **Cursor buttons [▲, ▼, ◀, ▶]**
Enter button [ENTER] 17
- ⑩ **On-screen menu icon button [OSD/DISPLAY]** 28
- ⑪ **Double re-master button [D.RE-MASTER] [SHIFT]** 27
- ⑫ **Position memory button [POSITION MEMORY]** 19
- ⑬ **Cancel button [CANCEL]** 21
- Subtitle button [SUBTITLE] [SHIFT]** 26
- ⑭ **Numbered buttons [1-9, 0, ≧10/ENTER]** 20
- ⑮ **Slow/search buttons [⏮, ⏭] SLOW/SEARCH** 18
- ⑯ **Play button [▶]** 18
- ⑰ **Menu button [MENU]** 19
- Play list button [PLAY LIST]** 24
- ⑱ **Return button [RETURN]** 17
- ⑲ **Quick replay button [QUICK REPLAY]** 20
- ⑳ **Zoom button [ZOOM]** 27
- ㉑ **Soundtrack button [AUDIO] [SHIFT]** 26

• If **SHIFT** appears after the button name the function will not work unless you use with **[SHIFT]** button. Make sure to press **[SHIFT]** and the button.

Remote control—VCR operation

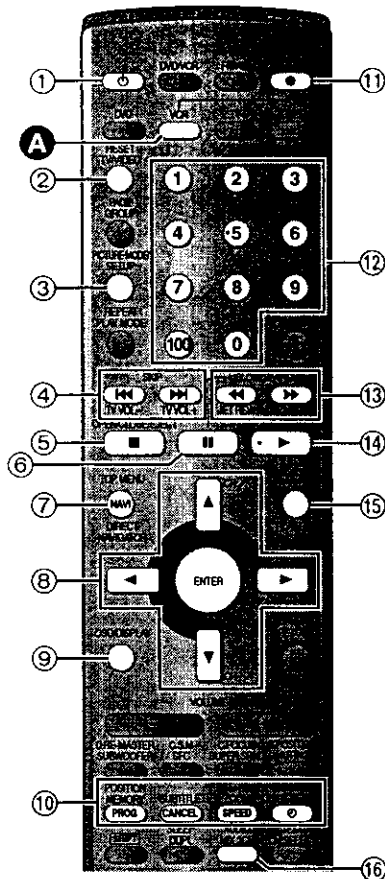

- A VCR remote control mode button [VCR]**34
Switch the remote control mode to VCR. Make sure you press before doing VCR operations. When in VCR mode, the [VCR] button lights each time you press one of the VCR operation buttons indicated below.
- 1 Power button [⏻]**15
Press to switch the unit from on to standby mode or vice versa. In standby mode, the unit is still consuming a small amount of power.
- 2 TV/Video button [TV/VIDEO]**16
Tape counter reset button [RESET] **[SHIFT]**45
- 3 Picture mode button [PICTURE MODE]**35
- 4 Index search button [◀▶ SKIP]**41
- 5 Stop button [■]**34
Cassette eject button [OPEN/CLOSE/EJECT] **[SHIFT]**34
- 6 Pause button [⏸]**34
- 7 Jet navigator button [NAV]**40
- 8 Cursor buttons [▲, ▼, ◀, ▶]**
Enter button [ENTER]38
Channel, tracking, and vertical hold buttons
[▲ CH▲] [▼ CH▼]35, 36
- 9 On-screen display button [OSD/DISPLAY]**45
- 10 Timer recording buttons**38
Timer programming button [PROG]
Cancel button [CANCEL]
Tape speed button [SPEED]
Timer program standby button [⊙]
- 11 Recording button [● REC]**36
- 12 Numbered buttons [1-9, 100, 0]**36
- 13 Fast-forward/rewind button [◀◀, ▶▶ SLOW/SEARCH]**34
Jet rewind button [◀◀ JET REW] **[SHIFT]**34
- 14 Play button [▶]**34
Press and hold for five seconds to start repeat play.35
- 15 Menu button [MENU]**42
- 16 Audio button [AUDIO] **[SHIFT]****45

Remote control—TUNER operation

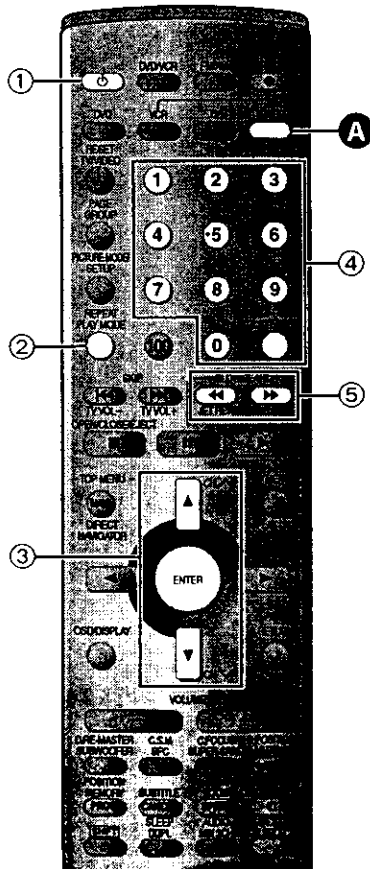

- A TUNER remote control mode button [TUNER]**46
Switch the remote control mode to TUNER. Make sure you press before doing TUNER operations. When in TUNER mode, the [TUNER] button lights each time you press one of the TUNER operation buttons indicated below.
- 1 Power button [⏻]**46
Press to switch the unit from on to standby mode or vice versa. In standby mode, the unit is still consuming a small amount of power.
- 2 FM mode button [PLAY MODE]**46
- 3 Channel buttons [▲ CH▲] [▼ CH▼]**
Enter button [ENTER]46
- 4 Numbered buttons [1-9, 0, ≥10/ENTER]**46
- 5 Tuning buttons [◀◀, ▶▶]**46

Main unit and subwoofer

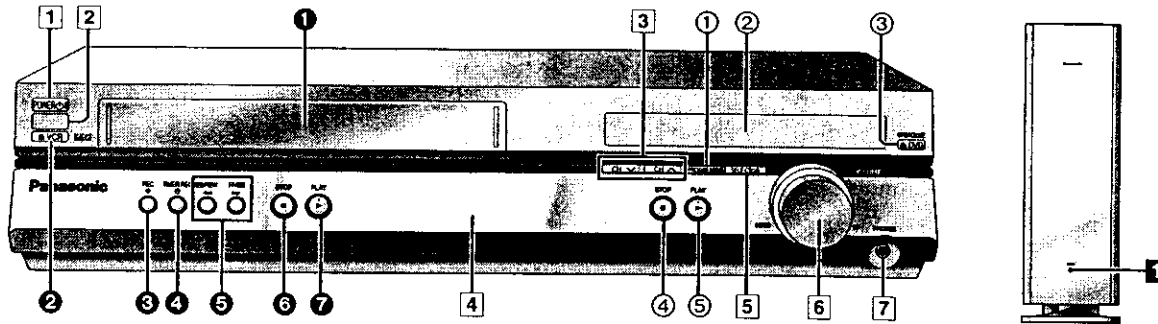

Common buttons

- 1 Power button [POWER] 15
Press to switch the unit from on to standby mode or vice versa. In standby mode, the unit is still consuming a small amount of power.
- 2 Remote control signal sensor
- 3 Channel buttons [CH \downarrow] [CH \uparrow] 36, 46
- 4 Display
- 5 Source selector buttons [SELECTOR]
VCR \rightarrow DVD \rightarrow FM \rightarrow AM
- 6 Volume dial [VOLUME DOWN, UP] 18
Volume may be lower when playing DVD-Video than when playing other discs or during television broadcasts. Reduce the volume before playing other sources or returning to the television so volume doesn't increase suddenly.
- 7 Headphone terminal [PHONES] 48

DVD section

- 1 Progressive video button [PROGRESSIVE] 18
- 2 Disc tray 18
- 3 Open/close button [Δ DVD OPEN/CLOSE] 18
- 4 Stop button [■ STOP] 18
- 5 Play button [▶ PLAY] 18

VCR section

- 1 Tape slot 34
- 2 Tape eject button [Δ VCR EJECT] 34
- 3 Recording button [● REC] 36
- 4 Timer recording button [⊙ TIMER REC] 38
- 5 Fast-forward and rewind buttons
[◀◀ REW] [▶▶ FF] 34
- 6 Stop button [■ STOP] 34
- 7 Play button [▶ PLAY] 34

Subwoofer

- 1 AC supply indicator [AC IN]
This indicator lights when the subwoofer is connected to a household AC outlet.

Main unit display

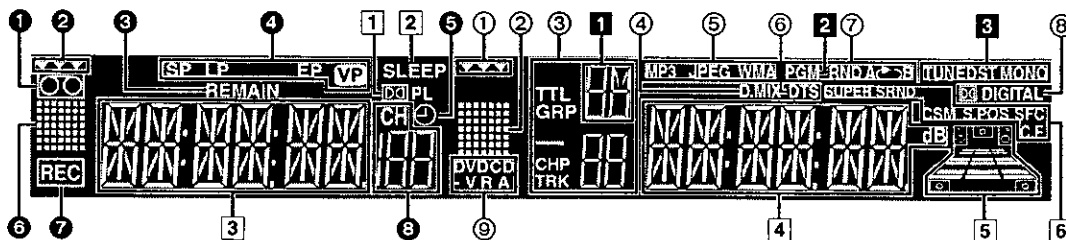

Common display

- 1 Dolby Pro Logic indicator 50
- 2 SLEEP timer indicator 48
- 3 Main display (Green)
Time display, video play/record elapsed time, program recording start time, various messages, etc.
- 4 Main display (Orange)
Disc play elapsed time, program recording end time, volume, TUNER frequency/channel display, various messages, etc.
- 5 Speaker channel, seat position display 51
- 6 Sound effect indicator
SUPER SRND: Super Surround 50
CSM: Custom Sound Memory 49
S.POS: Seat position 51
SFC: Sound Field Control 50
C.F: Center Focus 51

DVD operation

- 1 DVD selector indicator 18
Lights when DVD is selected. Flashes for about 5 seconds immediately after selection is made.
- 2 Operation display 18
Displays play and pause, etc.
- 3 Title/Group/Chapter/Track number display 6
- 4 Down mix indicator 50
- 5 MP3/JPEG/WMA indicator 6
- 6 DTS indicator 50

Play sequence indicator

- PGM: During program play 25
- RND: During random play 25
- ↻: During repeat 21
- A↻B: During A-B repeat 21
- 8 Dolby Digital indicator 50
- 9 Disc type indicator 6

VCR operation

- 1 Video cassette indicator
Shows whether you have loaded a video cassette.
- 2 VCR selector indicator 34
Lights when the selector is in VCR mode. Flashes for about 5 seconds immediately after selection is made.
- 3 Tape remaining display indicator 45
- 4 Tape speed indicator 36
- 5 Timer program recording indicator 38
- 6 Operation display 34
Displays play, fast-forward, or rewind, etc.
- 7 Recording indicator 36
- 8 Channel display

Tuner operation

- 1 Band display
- 2 Preset indicator 46
- 3 Radio broadcast display 46
TUNED: Receiving radio signal
ST: Stereo
MONO: Forced monaural

Simple setup

STEP 1 Locating

SC-HT810V

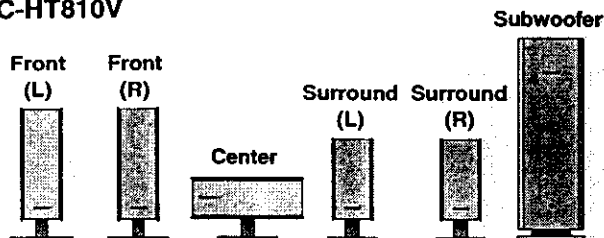

SC-HT790V, SC-HT800V

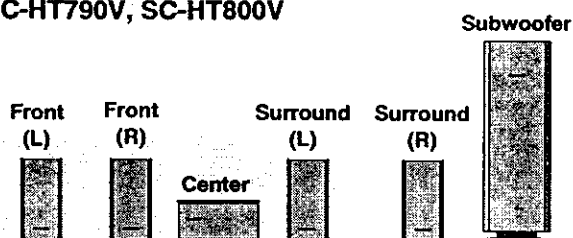

The illustration shows SC-HT810V.

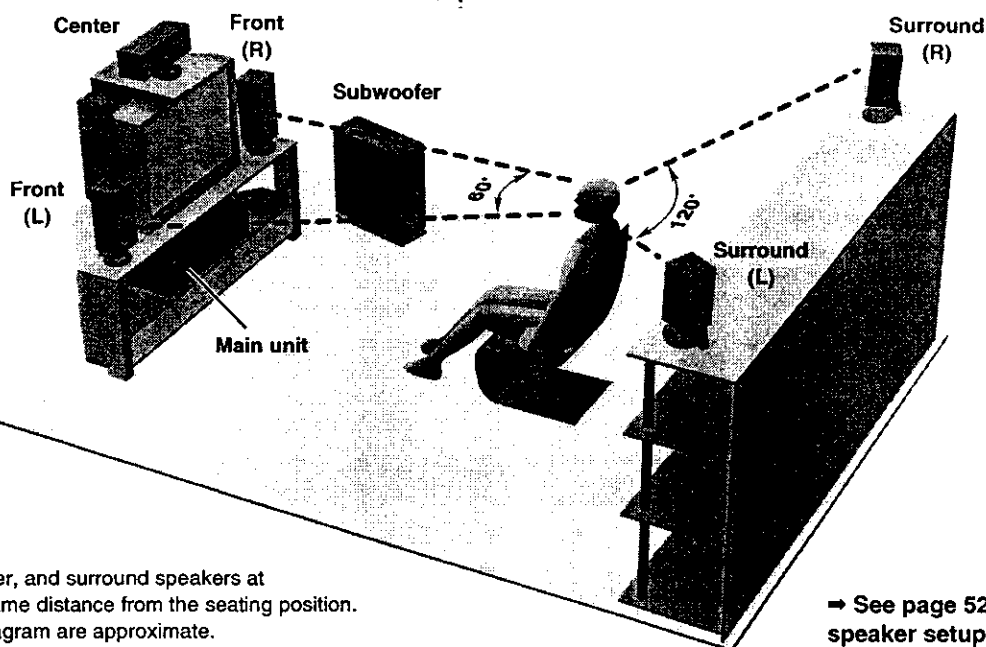

Place the front, center, and surround speakers at approximately the same distance from the seating position. The angles in the diagram are approximate.

➔ See page 52 for other speaker setup options.

● Use only supplied speakers

Using other speakers can damage the unit and sound quality will be negatively affected.

- Set the speakers up on an even surface to prevent them from falling. Take proper precautions to prevent the speakers from falling if you cannot set them up on an even surface.

Positioning for best effect

How you set up your speakers can affect the bass and the sound field. Note the following points.

- Place speakers on flat secure bases.
- Placing speakers too close to floors, walls, and corners can result in excessive bass. Cover walls and windows with thick curtain.

Main unit

Note

Keep your speakers at least 10 mm (13/32") away from the system for proper ventilation.

Center speaker

- You can also put this speaker directly under the television.
- Vibration caused by the center speaker can disrupt the picture if it is placed directly on the television. Put the center speaker on a rack or shelf.

Subwoofer

Place to the right of the television, on the floor or a sturdy shelf so that it won't cause vibration.

Leave 10 cm (4") on the right for the woofer to be effective. Leave 10 cm (4") at the rear for ventilation.

Notes on speaker use

- You can damage your speakers and shorten their useful life if you play sound at high levels over extended periods.
- Reduce the volume in the following cases to avoid damage.
 - When playing distorted sound.
 - When the speakers are receiving howling from a record player, noise from FM broadcasts, or continuous signals from an oscillator, test disc, or electronic instrument.
 - When adjusting the sound quality.
 - When turning the unit on or off.



Caution

- Use the speakers only with the recommended system. Failure to do so may lead to damage to the amplifier and/or the speakers, and may result in the risk of fire. Consult a qualified service person if damage has occurred or if you experience a sudden change in performance.
- Do not attempt to attach these speakers to walls using methods other than those described in this manual.

STEP 2

Speakers

Speaker cables

- 3 x 4-m (13-foot) cables
- 2 x 10-m (33-foot) cables



Sheet of speaker-cable stickers



The illustrations show SC-HT810V.

Setup example

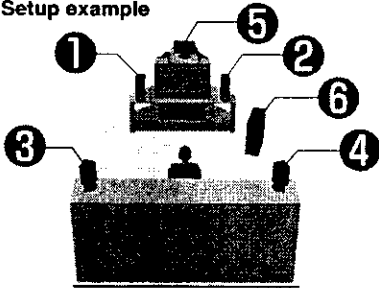

SC-HT790V, SC-HT800V

The front and surround speakers are the same. Use those you have connected the short cords to as front speakers and those you have connected the long cords to as surround speakers.



1 Attaching the stickers to the speaker cables

Attach the speaker-cable stickers to make connection easier.

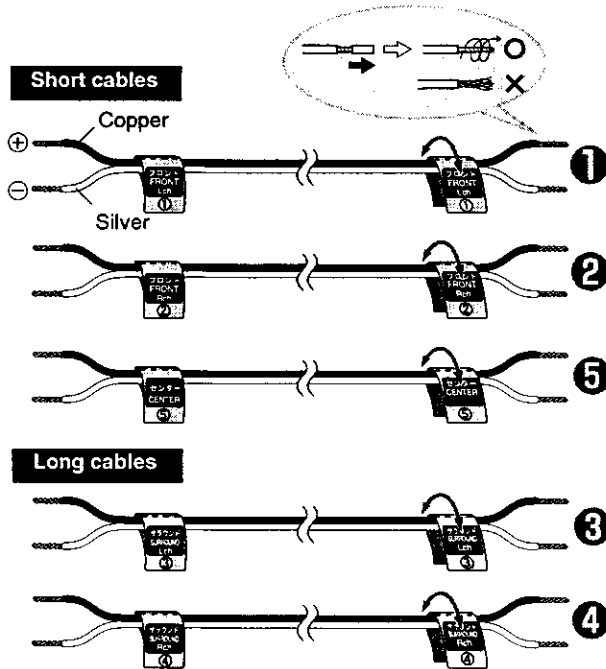

2 Connecting the speakers

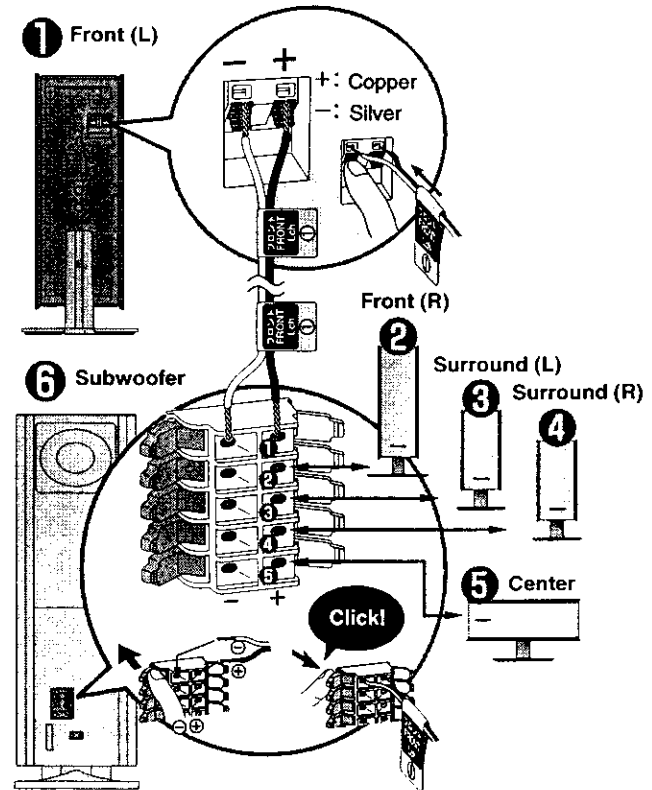

Keeping the cables out of the way (SC-HT810V only)

Pass the cables through the holes in the stand to keep them out of the way.

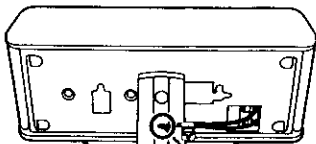

- 1 Pass the cable through the hole.
- 2 Pass through the cutout in the base.

Note

- Never short-circuit positive (+) and negative (-) speaker wires.
- Be sure to connect only positive (copper) wires to positive (+) terminals and negative (silver) wires to negative (-) terminals. Incorrect connection can damage the speakers.

Caution

Hold the speakers by the sides. Applying pressure to the front net can damage the speaker.

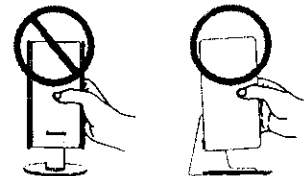

STEP 3 Television

Basic connection

75 Ω coaxial cable

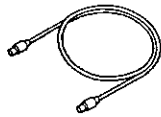

Video cable



Television
(not included)

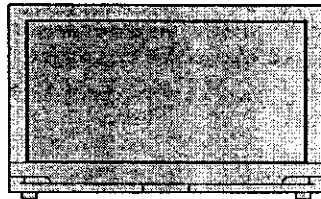

VIDEO
IN

VHF/UHF
RF IN

Video cable
(included)

75 Ω coaxial
cable
(included)

If the connector
doesn't match
→ page 55

Main unit



If the connector
doesn't match
→ page 55

Antenna cable
(usually disconnected
from the television)

75 Ω coaxial cable

This cable carries broadcast signals to the television whether the unit is on or off so you do not need to connect the antenna directly to the television.

It does not carry other signals from this unit, so make sure you connect the television to VIDEO OUT. Contact your dealer if your television does not have the corresponding terminal.

Connect video cables directly to your television

The video signals on DVDs and videotapes have copyright protection. The video may not be shown correctly if you connect through an A/V selector or other equipment.

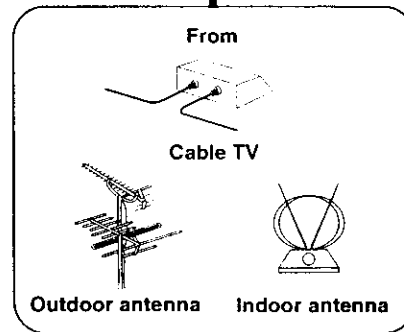

To enjoy cable and satellite television

Connection → page 54

Subscribe to a cable or satellite company.

If irregular coloring occurs on your television

The supplied speakers are designed to be used close to a television, but the picture may be affected with some televisions and setup combinations.

If this occurs, turn the television off for about 30 minutes.

The television's demagnetizing function should correct the problem. If it persists, move the speakers further away from the television.



For better video from DVD

The following connections are for video from the DVD section only. Make sure you have connected the VIDEO OUT terminal with the television to view video from the VCR section (⇒ page 12).

You may need to change the video-input mode on the television to view video from the VCR and DVD sections. Read your television's operating instructions for details.

■ Connecting a television with COMPONENT VIDEO terminals

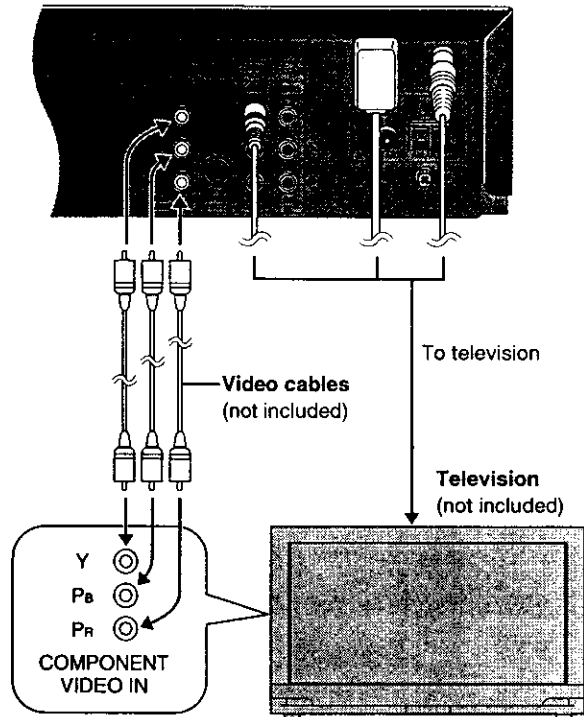

COMPONENT VIDEO OUT terminal

These terminals can be used for either interlace or progressive output and provide a purer picture than the S-VIDEO OUT terminal. Connection using these terminals outputs the color difference signals (P_B/P_R) and luminance signal (Y) separately in order to achieve high fidelity in reproducing colors.

- The description of the component video input terminals depends on the television or monitor (e.g. Y/P_B/P_R, Y/B-Y/R-Y, Y/C_B/C_R). Connect to terminals of the same color.
- After making this connection, change the black level for a better picture (⇒ page 31, Video—Black Level Control).

To enjoy progressive video

- Connect to the component video input terminals on a 480P compatible television. (Video will not be displayed correctly if connected to an incompatible television.)
- All televisions manufactured by Panasonic and that have 480P input connectors are compatible. Consult the manufacturer if you have another brand of television.

■ Connecting a television with an S-VIDEO IN terminal

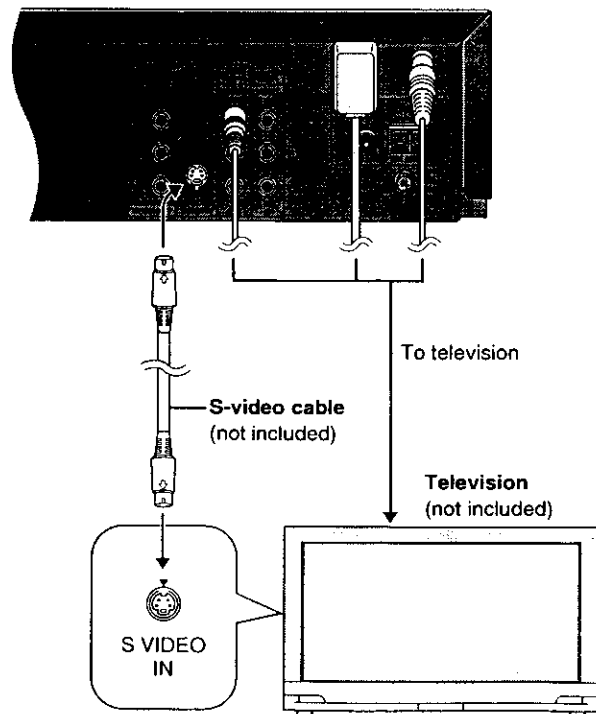

S-VIDEO OUT terminal

The S-video terminal achieves a more vivid picture than the VIDEO OUT terminal by separating the chrominance (C) and luminance (Y) signals. (Actual results depend on the television.)

Note

Connect to a different terminal group than that you used for the video cable (e.g., "VIDEO 2").

Picture from this unit's VCR will not appear when you use the same group input terminal connections because the S-video terminal input takes precedence.



STEP 4

Connecting the subwoofer, antennas, and AC power supply cords

System cable



AM loop antenna



FM indoor antenna



2 AC power supply cords

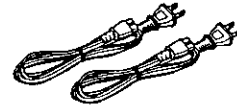

Connect the AC power supply cord after all other connections are complete.

Subwoofer

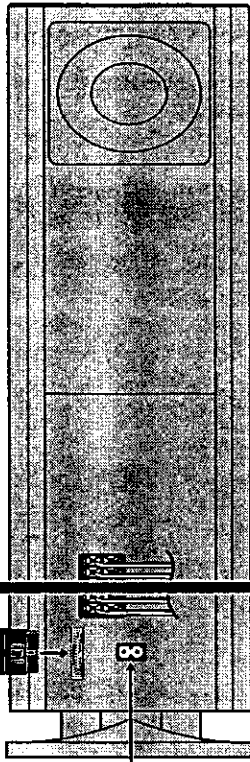

Adhesive tape
Fix the other end of the antenna
where reception is best.

AC power supply cord

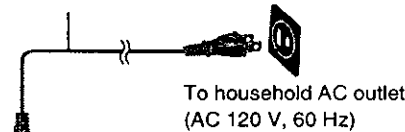

To household AC outlet
(AC 120 V, 60 Hz)

Main unit



AM loop antenna



Stand the antenna
up on its base.
Keep loose antenna
cord away from other
wires and cords.

FM indoor
antenna



System cable

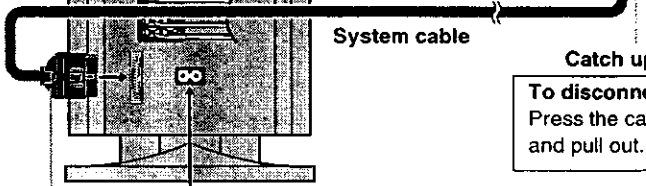

Catch up

To disconnect
Press the catch
and pull out.

AC power supply cord

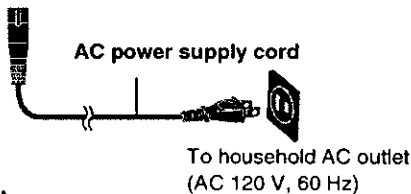

To household AC outlet
(AC 120 V, 60 Hz)

Catch to the right

To disconnect
Press the catch
and pull out.

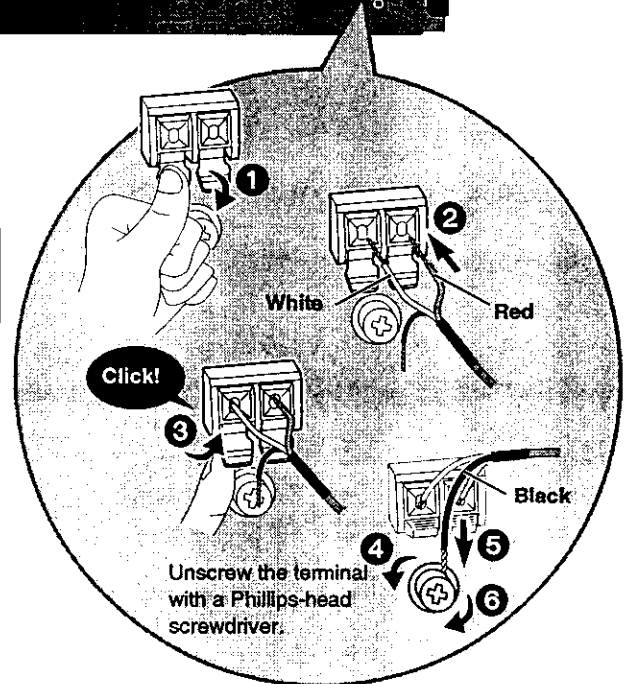

Unscrew the terminal
with a Phillips-head
screwdriver.

AC power supply cords

Connect both AC power supply cords to enjoy all the features of this system.

Conserving power

This unit consumes a small amount of power, even when it is turned off. The amount of power used depends on the display setting (→ page 44):

BRIGHT: 3.7 W DIM: 3.5 W OFF: 2.4 W

Audio memory backup

To save power when the unit is not to be used for a long time, unplug it from the household AC outlet.

Remember to reset the radio stations and any other memory items before using the unit again.

Information you enter into the unit's memory remains intact for up to 2 weeks after the subwoofer's AC power supply cord is disconnected.

STEP 5 Plug-in Auto Tuning

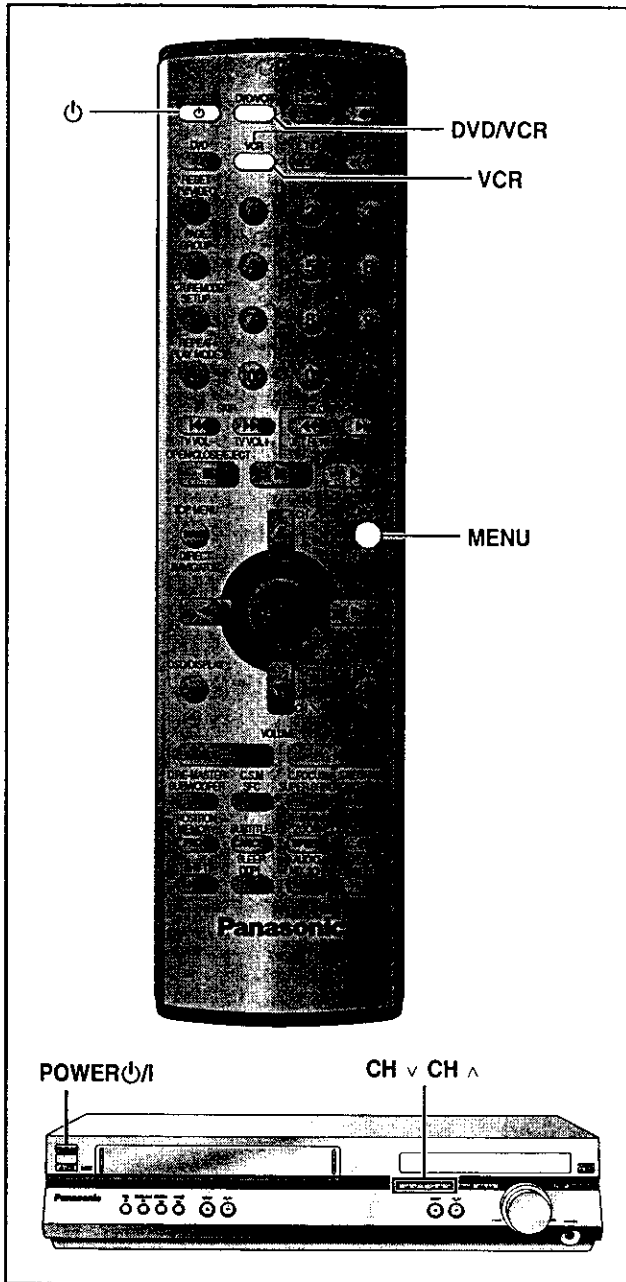

After plugging the unit into your household AC outlet and pressing [⏻] to turn the unit on for the first time, the unit automatically tunes in all the channels it can receive and sets the clock.

The unit determines the type of transmission, TV or CATV, as follows:

- TV: when there are less than 5 CATV channels.
- CATV: when there are 5 or more CATV channels.

Preparation

- Confirm that the antenna is connected correctly.
- Turn on the television and select the video input for the VCR.
- Press [VCR] to put the remote control in VCR mode.

Press [⏻] to turn on the unit.

Plug-in Auto Tuning starts and the unit puts the stations it can receive into channels (⇒ page 43, Channel range).

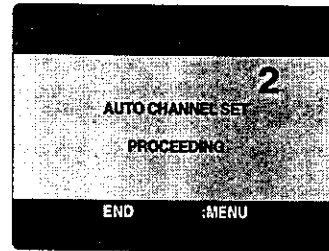

The unit starts auto clock setting when finished, then displays the time.

Note

If auto tuning stops partway (by changing the source, turning the unit off, or due to a power failure.)

- 1 Disconnect the AC power supply cord on the main unit and then reconnect it.
- 2 Turn on the main unit.

To cancel partway

Press [MENU].

■ To start Plug-in Auto Tuning again (after relocation, for example)

Preparation

- Press [⏻] to turn on the unit.
- Make sure there is no video cassette tape loaded in the unit.
- Press [DVD/VCR] to select "VCR" as the source.

- 1 Press and hold [CH v] and [CH ^] on the main unit simultaneously for 3 seconds until the channel changes to "2".



Disappears → 2

- 2 Disconnect the AC power supply cord on the main unit and then reconnect it.
- 3 Turn on the main unit. Plug-in Auto Tuning restarts.

Antenna system and channel captions all revert to the default values when you perform the procedure above. Reset the timer recording settings. (If necessary reset the clock first. ⇒ page 42, CLOCK SET)

■ To set the channels manually (⇒ page 43).

■ If the unit couldn't set the clock automatically
The MANUAL CLOCK SET screen appears. Set the time manually (⇒ page 42).



STEP 6

Operating the television

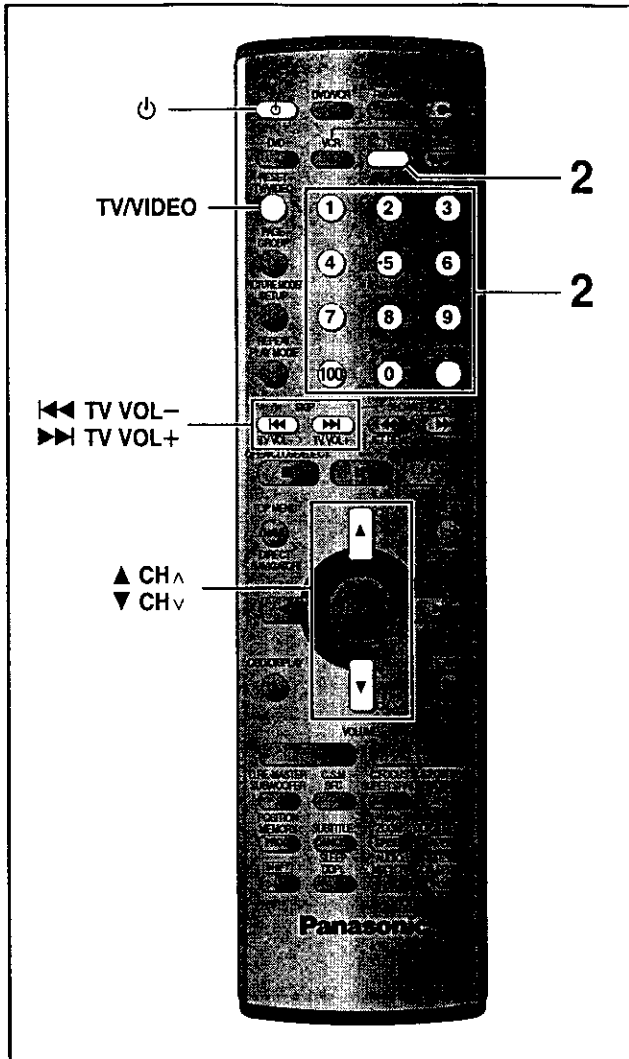

■ TV maker setting

You can control the television by entering the remote control code.

1 Refer the chart below for the code for your television.

2 Aiming the remote control at the television

While pressing and holding [TV], press the numbered buttons to enter the code number.

- Example: To select 01, press [0] → [1].
- The remote control outputs the on/off signal. If the code is correct, the equipment turns on or off. If it doesn't, try entering another code.

Note

- If your television brand is not listed or if the code listed for your television does not allow control of your television, this remote control is not compatible with your television.
- Reenter the codes after you change the batteries.

■ TV operation

Operation	Buttons
Power on/standby	[⏻]
Remote control TV mode	[TV] • Switch the remote control mode to TV. Press before doing TV operations. When in TV mode, the [TV] button lights each time you press an operation button.
TV/Video switch	[TV/VIDEO]
Selecting channels	[▲ CH^][▼ CHv] or numbered buttons [1-9, 100, 0, ≧10/ENTER]. • [≧10/ENTER] is used to confirm channel selection on some televisions manufactured by other companies.
Adjusting volume	[◀◀ TV VOL-][▶▶ TV VOL+]

Manufacturer	Code No.	Manufacturer	Code No.
Panasonic	01, 02	PHILIPS	06
FISHER	14	PIONEER	02, 10, 19
G.E.	02, 03, 07, 09	QUASAR	02
GOLD STAR	07, 15	RCA	03, 07, 09, 13, 23, 24, 25
HITACHI	05, 07	SANYO	14
JVC	12	SHARP	08, 21
LXI	03, 06, 07, 10, 14, 15	SONY	04
MAGNAVOX	06, 07, 11, 15, 22	SYLVANIA	06, 07, 15
MITSUBISHI	07, 15, 16, 21	SYMPHONIC	17
NEC	07, 15	TOSHIBA	10, 21
PHILCO	06, 07	ZENITH	18, 20



STEP 7 DVD QUICK SETUP

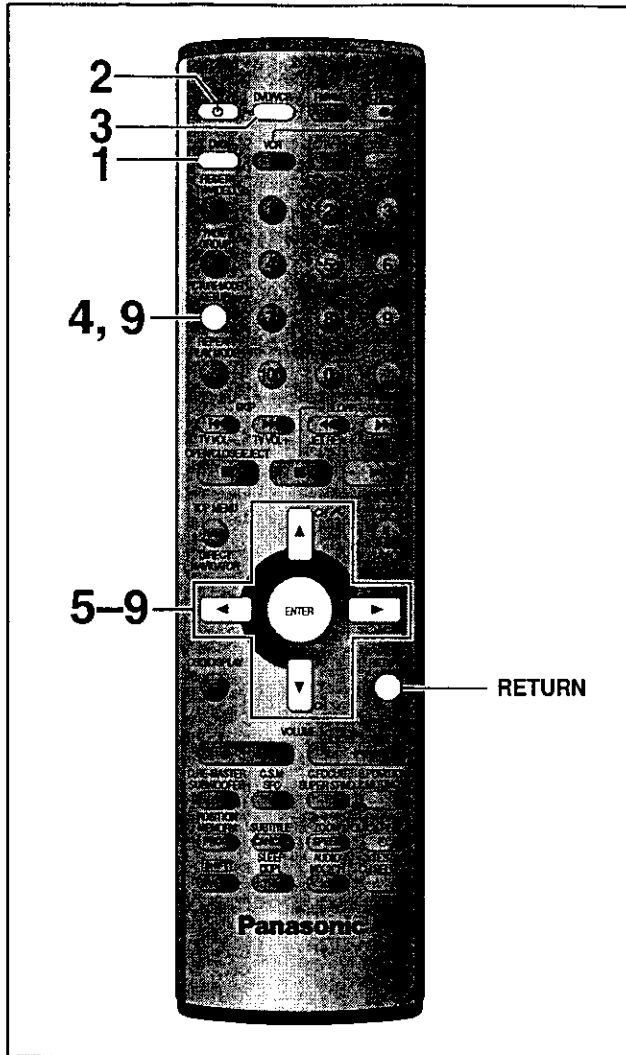

Answer questions in the QUICK SETUP screen to make some simple DVD settings.

Preparation

Turn on the television and select the video input for the DVD.

- 1 Press [DVD] to put the remote control in DVD mode.
- 2 Press [⏻] to turn on the unit.
- 3 Press [DVD/VCR] to select “DVD” as the source.
- 4 Press [SETUP] to show the menus.

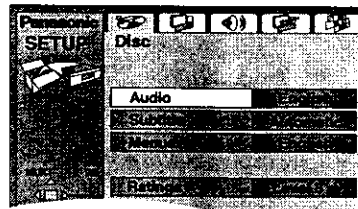

- 5 Press [◀, ▶] to select “Others” tab.
- 6 Press [▲, ▼] to select “QUICK SETUP” and press [ENTER].
- 7 Press [▲, ▼] to select “Yes” and press [ENTER].
- 8 Press [▲, ▼] to select the item and press [ENTER].
 - Menu Language (⇒ page 31)
 - Audio Language (⇒ page 31)
 - Subtitle Language (⇒ page 31)
 - TV Type (⇒ below)
 - TV Aspect (⇒ below)
- 9 Press [ENTER] and then [SETUP] to end the settings.

To return to the previous screen
Press [RETURN].

■ TV Type

Select to suit the type of television.

- Standard (Direct View TV) (factory preset)
- CRT Projector
- LCD TV/Projector
- Projection TV
- Plasma TV

■ TV Aspect

Select “4:3” (regular) or “16:9” (widescreen) to suit your television.

If you have a regular 4:3 television, you can also select how video on some discs is shown (⇒ page 31, Video—TV Aspect).

- 4:3 Pan&Scan (factory preset)
Widescreen software is expanded to fill the screen of a 4:3 aspect television (unless prohibited by the producer of the disc).
- 4:3 Letterbox
Widescreen software is shown in the letterbox style on a 4:3 aspect television.



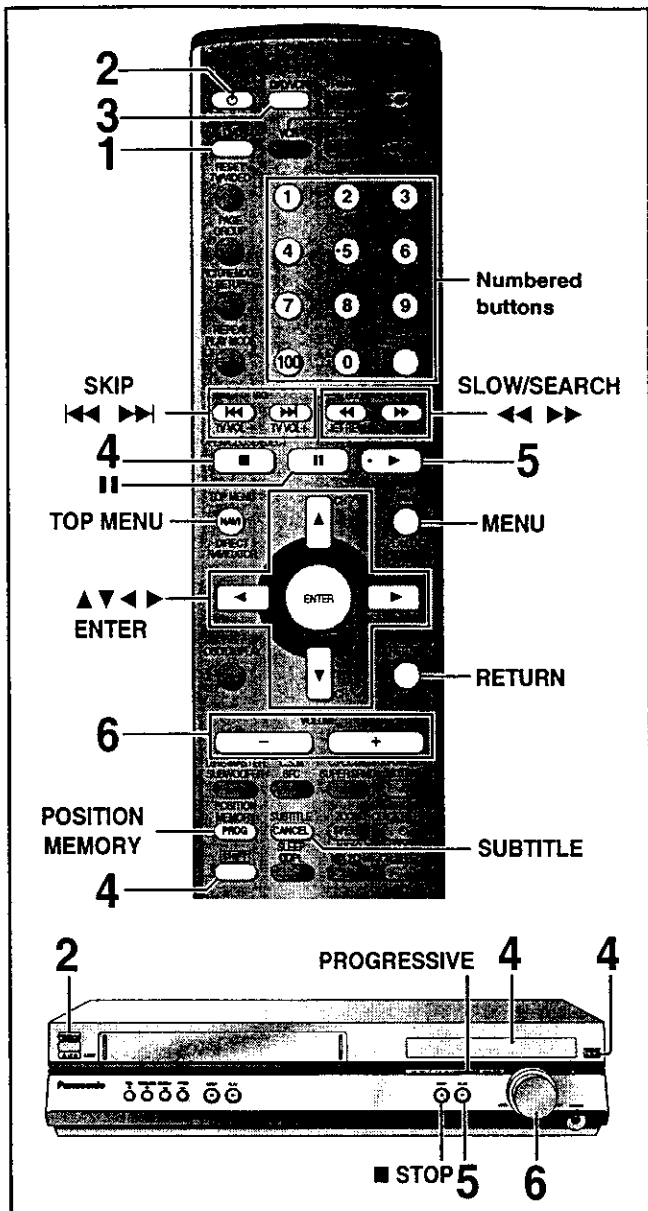

RAM DVD-A DVD-V VCD CD WMA MP3 JPEG

To enjoy progressive video

Press [PROGRESSIVE] on the main unit so "PR ON" appears on the display.



To check whether progressive output is on or off Press [PROGRESSIVE]. "PR ON" (on) or "PR OFF" (off) appears on the display.

Note

- The television will be disrupted for a moment but this is normal.
- Output from this unit is interface if you have connected to the television through VIDEO OUT or S-VIDEO OUT terminals, irrespective of the setting.
- When progressive output is on, closed captions will not be displayed.

Preparation

Turn on the television and select the video input for the DVD.

- 1 Press [DVD] to put the remote control in DVD mode.
- 2 Press [Power] to turn on the unit.
- 3 Press [DVD/VCR] to select "DVD" as the source.

The following indicator appears when you select DVD.



- 4 Press [SHIFT]+[OPEN/CLOSE/EJECT] to open the disc tray and place the disc.

•If the disc contains both audio data (WMA and MP3) and JPEG, check "Mixed Disc—Audio & Stills" in the SETUP menu (→ page 31). Select "Stills (JPEG)" or "Audio (MP3/WMA)".

•Load double-sided discs so the label for the side you want to play is facing up.



- 5 Press [▶] (play).

The disc tray closes and play begins. It is normal for sound and pictures to take time to start.

WMA MP3 CD (CD text only)

Track information appears on the television. Press [SHIFT]+[SUBTITLE] to turn the display on or off.

- 6 Adjust the volume.

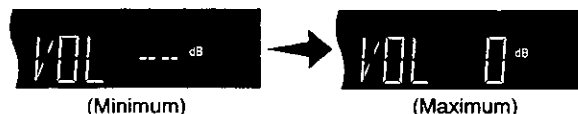

Stop	Press [■] (→ page 19, Resume function).
Pause	Press [⏸].
Skip	Press [◀▶] (backward) or [▶▶] (forward). Group skip [JPEG] Press [▼] (backward) or [▲] (forward).
Search	Press [◀◀] (backward) or [▶▶] (forward). You can turn off the sound (→ page 31, Audio—Audio during Search).
Slow	While paused, press [◀◀] (backward) or [▶▶] (forward).
Frame-by-frame	While paused, press [◀] (backward) or [▶] (forward). Press and hold to change in succession. Or, press [⏸] repeatedly for forward frame-by-frame.

Notes

- Press [▶] (PLAY) to restart play.
- The speed of search and slow-motion increases up to 5 steps.
- When playing Video CDs**
- You cannot move backwards during slow-motion and frame-by-frame.
- Pressing buttons to perform skip, search or slow-motion may take you to a menu screen.

Note

- If "⊘" appears on the television
The operation is prohibited by the unit or disc.

When a menu appears on the television

DVD-A DVD-V VCD

Press [**▲**, **▼**, **◀**, **▶**] to select an item and [**ENTER**] to confirm.
Or, press the numbered buttons.

To select a 2-digit number

e.g. 23: [**≧10**] → [**2**] → [**3**].

Press [**TOP MENU**] to show the top menu.

Press [**MENU**] to show a menu.

Press [**RETURN**] to show a menu. **VCD**

Note

The disc continues to rotate while the menu is displayed even after you finish playing an item. Press [**■**] when you finish to preserve the unit's motor and your television screen.

Position Memory function

RAM DVD-A DVD-V VCD CD WMA MP3

(When the elapsed play time is displayed)

JPEG

During play

Press [**POSITION MEMORY**] to memorize a position.

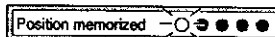

Press again to replace the position.

This position is saved even if you turn the unit off, change the source or open the disc tray. When you turn the unit on, reselect DVD or reinsert the disc whose position you memorized, "▷" flashes on the display. Press [**▶**] (play) to start play from the memorized position. The position is cleared.

- You can memorize positions on up to five different discs at a time. When you memorize another position, the earliest position is replaced.

Resume function

"▷" flashes on the display when the unit has recorded the position at which you stopped play.

Press [**▶**] (play) to start play from that position.

- The position is cleared when you:
 - Turn the unit off.
 - Select another source.
 - Open the disc tray.
- Press [**■**] to clear the position.

Chapter Preview

DVD-V

The following message appears immediately after you press [**▶**] (play) when "▷" is displayed.

Press [**▶**] (play) while the message is displayed and the beginning portions of each chapter up to the current one are played.

Full play resumes from the point where you pressed [**■**] or [**POSITION MEMORY**].

(This feature works only within a title.)

If you do not press [**▶**] (play), the message disappears and play starts from where you pressed [**■**] or [**POSITION MEMORY**].



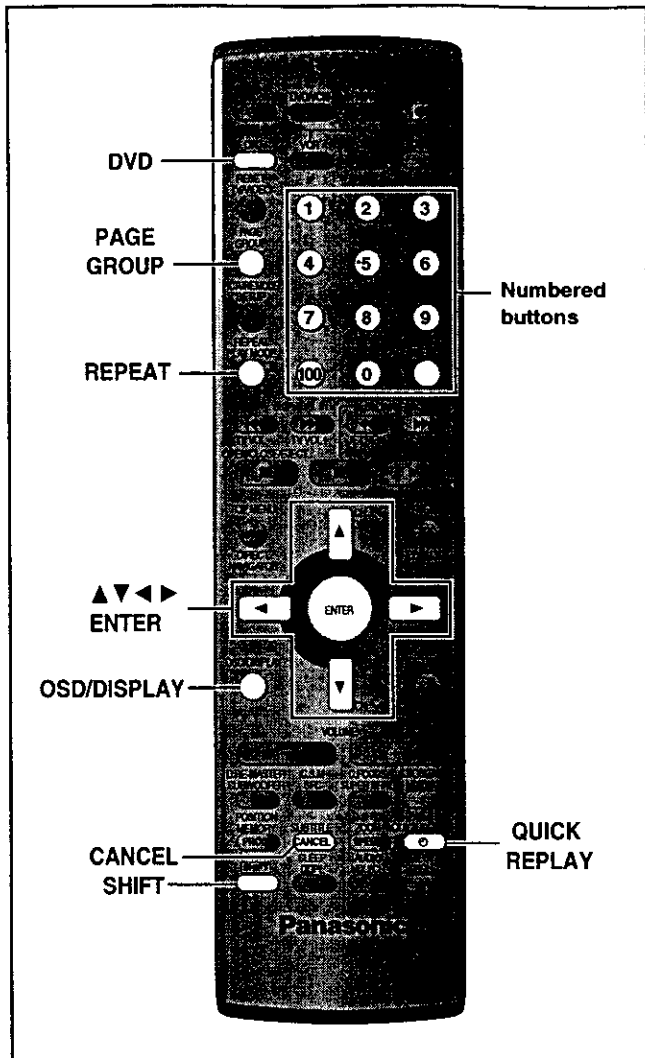

Selecting groups to play

DVD-A | WMA | MP3 | JPEG

1 Press [GROUP].

e.g. MP3



Group number | Track No. in disc
Track No. in group | Total No. of tracks on disc

2 Press [▲, ▼] to select the group number and press [ENTER].

3 Press [▲, ▼] to select the track/picture number and press [ENTER].

• You can also select the group and track/picture number with the numbered buttons.

DVD-A

• Playing all the groups in succession (⇒ page 25, All group play)

• Playing bonus groups

Some discs contain bonus groups. If a password screen appears after selecting a group, enter the password with the numbered buttons. Refer also to the disc's jacket.

Rotating pictures

JPEG

While a picture is displayed

1 Press [OSD/DISPLAY] until the disc information screen is displayed (⇒ page 29).



Angle

2 Press [◀, ▶] to select "Angle" and press [▲, ▼] to select the rotation angle.

The picture rotates ninety degrees each time you do this.

0 ↔ 90 ↔ 180 ↔ 270

Selecting still pictures—Page Skip

DVD-A

During play

Press [SHIFT]+[PAGE].

The page changes each time you do this.

PAGE 1

Replaying a scene—QUICK REPLAY

RAM | DVD-A | DVD-V | VCD | CD | WMA | MP3

Skip back a few seconds within the current item (program, track or title).

JPEG: Skip back a few pictures.

During play

Press [QUICK REPLAY].

Note

This feature may not work while playing some parts of a disc or at all with some discs.

Starting play from a selected item

RAM | DVD-A | DVD-V | VCD | CD

Press the numbered buttons.

To select a 2-digit number

e.g. 23: [≧10] ⇒ [2] ⇒ [3].

WMA | MP3 | JPEG

Press the numbered buttons then press [ENTER].

e.g. 123: [1] ⇒ [2] ⇒ [3] ⇒ [ENTER].

• This works only when stopped with some discs.

• When playing DVD-Audio and you want to start play from a track in a different group, select the group first (⇒ right).

Repeat play

RAM DVD-A DVD-V VCD CD WMA MP3

(When the elapsed play time is displayed)

JPEG

During play

Press

[SHIFT]+[REPEAT].

Each time you do this:

RAM

Program→All (Entire disc)→Off

• During play list play

Scene→Playlist→Off

DVD-V

Chapter→Title*→Off

VCD CD

Track→All (Entire disc)→Off

DVD-A WMA MP3

Track→Group*→Off

JPEG

Group→Off

*During all group (DVD-A), program and random play

"All" is displayed.

You can also repeat play of content and group on HighMAT discs.

DVD-A DVD-V VCD CD WMA MP3

■ To repeat only your favorite tracks/chapters

Start program play (⇒ page 25) and press [SHIFT]+[REPEAT] to display "All".

A-B repeat play

RAM DVD-A DVD-V VCD CD WMA MP3

(When the elapsed play time is displayed)

You can repeat a section between points A and B within an item.

1 During play

Press [OSD/DISPLAY] until the unit information screen is displayed

(⇒ page 29).

2 Press [▲, ▼] to select the play menu.



A-B Repeat

3 Press [◀, ▶] to select "A-B Repeat" and

① Press [ENTER] at the starting point (A).

② Press [ENTER] at the finishing point (B).

A-B repeat starts.



Marking places to play again

RAM DVD-A DVD-V VCD CD WMA MP3 JPEG

You can mark positions so you can return to them easily at a later time.

1 During play

Press [OSD/DISPLAY] until the unit information screen is displayed

(⇒ page 29).

2 Press [▲, ▼] to select the play menu.

e.g. DVD-V



Marker

3 Press [◀, ▶] to select "Marker" and press [ENTER].

RAM only

Then press [▶] to select an asterisk (*).

4 Press [ENTER] at the point you want to mark.

To mark another position

Up to 5 points (RAM only: up to 999 points)

1 Press [▶] to select "*".

2 Press [ENTER] at the point.

To recall or erase a marker

1 Press [◀, ▶] to select a marker.

2 Press [ENTER] to recall or press [CANCEL] to erase.

RAM

To mark the eleventh point and beyond

1 Press [◀, ▶] to select the marker pin icon.



2 Press [▲, ▼] to select "11-20".

You can select the next group when the current group is full.

Note

Markers added with this unit clear when you switch the unit to standby, change the source, or open the disc tray.



To return to the normal play

Press [ENTER] again.

Note

A-B repeat is canceled when you press [QUICK REPLAY].

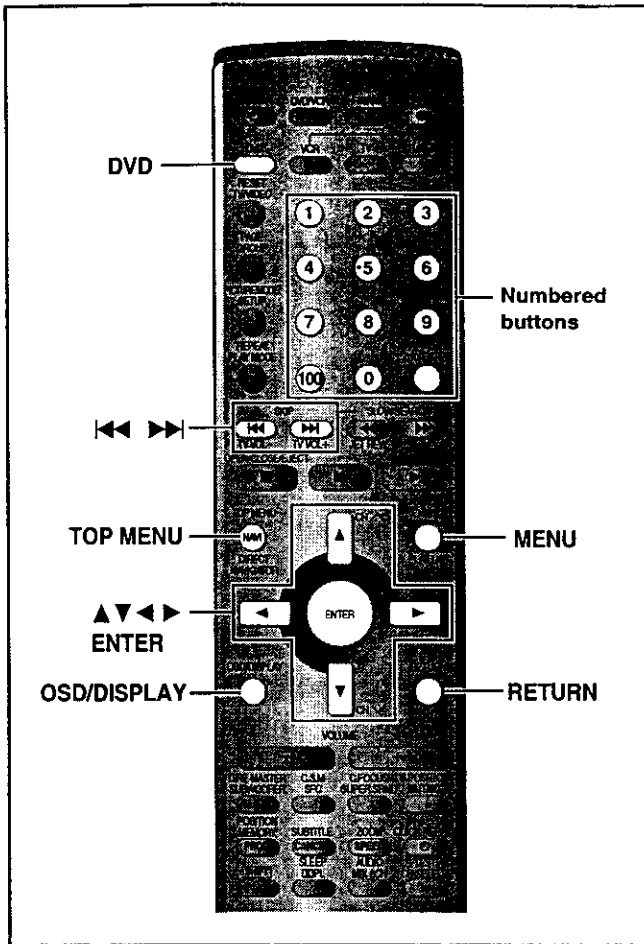

If the disc contains both audio data (WMA and MP3) and JPEG, check "Mixed Disc—Audio & Stills" in the SETUP menu (→ page 31). Select "Stills (JPEG)" or "Audio (MP3/WMA)".

WMA MP3 CD (CD text only) JPEG

These menus help you find items you want to start play.

1 Press [TOP MENU].

WMA/MP3 Audio navigation menu JPEG Album display

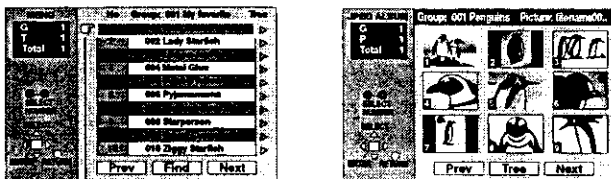

"G" indicates the track currently playing.

2 Press [▲, ▼] to select the track or [▲, ▼, ◀, ▶] to select the picture, and press [ENTER].

To show other pages, press [▲, ▼, ◀, ▶] to select "Prev" or "Next" and press [ENTER].

• After listing all the tracks or pictures in one group, the list for the next group appears.

To exit the menu

Press [TOP MENU].

Track title search WMA MP3 CD (CD text only)

Example: finding a track including the word "LOVE".

While the menu is displayed

1 Press [▲, ▼, ◀, ▶] to select "Find" and press [ENTER].



2 Press [▲, ▼] to select "L" and press [ENTER].

Only uppercase appear but the search also includes lower case. Characters change in alphanumeric order each time you press [▲].

Repeat this step to enter "O", "V", and "E".

• Press [◀, ▶] to skip between A, E, I, O and U.

• Press [◀] to erase a character.

• You can erase the asterisk (*) to search for the first word in a title.

• You can enter numbers with the numbered buttons.

3 Press [▶] to select "Find" and press [ENTER].

The search results screen appears.

4 Press [▲, ▼] to select the track and press [ENTER].

To return to the menu

Press [RETURN].

To use the contents screen to find a track

CD (CD text only)

You can use the text information recorded on these discs to find a track to play.

While the menu is displayed

1 Press [▶] while a track is highlighted to display the contents screen.

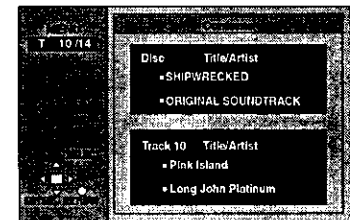

2 Press [◀, ▶] to move through the tracks and press [ENTER].

To return to the menu

Press [RETURN].

Windows Media, and the Windows logo are trademarks, or registered trademarks of Microsoft Corporation in the United States and/or other countries.



WMA is a compression format developed by Microsoft Corporation. It achieves the same sound quality as MP3 with a file size that is smaller than that of MP3.

MPEG Layer-3 audio decoding technology licensed from Fraunhofer IIS and Thomson multimedia.

To use the tree screen to find a group

WMA MP3 JPEG

While the menu is displayed

1

WMA MP3

Press [▶] while a track is highlighted to display a tree screen.

JPEG

Press [▲, ▼, ◀, ▶] to select "Tree" and press [ENTER].

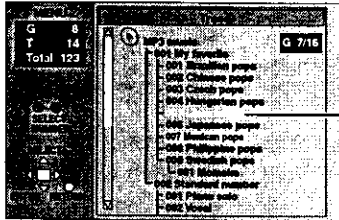

You cannot select groups that contain non-compatible files.

2 Press [▲, ▼, ◀, ▶] to select a group and press [ENTER].

The audio navigation menu/album display for the group appears.

To return to the menu

Press [RETURN].

Note

WMA

- You cannot play WMA files that are copy protected.
- Noise may occur when playing WMA files.
- WMA files must have the extension ".WMA" or ".wma".

MP3

- This unit is not compatible with ID3 tags.
- If you play an MP3 track that includes still picture data, it will take some time before the music itself starts playing and the elapsed time will not be displayed during this time. Even after the track starts, the correct play time will not be displayed.
- MP3 files must have the extension ".MP3" or ".mp3".

JPEG

- To view JPEG files on this unit:

- Take them on a digital camera that meets the DCF (Design for Camera File System) standard. Some digital cameras have functions that are not supported by the DCF standard like automatic picture rotation which may render a picture unviewable.
- Do not alter the files in any way or save them under a different name.
- Ensure they have the extension ".JPG", ".jpg", ".JPEG", or ".jpeg".
- This unit cannot display moving pictures, MOTION JPEG and other such formats, still pictures other than JPEG (i.e. TIFF) or play associated sound.

WMA MP3 JPEG

- Discs must conform to ISO9660 level 1 or 2 (except for extended formats).
- This unit is compatible with multi-session but if there are a lot of sessions it takes more time for play to start. Keep the number of sessions to a minimum to avoid this.

Naming folders and files

At the time of recording, prefix folder and file names with 3-digit numbers in the order you want to play them (this may not work at times).

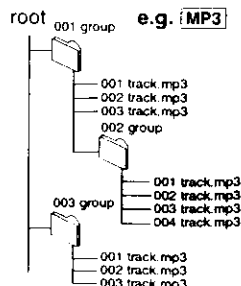

Playing HighMAT discs

A menu appears after you insert the disc.

Press [▲, ▼, ◀, ▶] to select then press [ENTER].

When you press [ENTER]:



Menu: Takes you to the next menu which shows play lists or another menu



Play list: Play starts

To return to the menu screen

Press [TOP MENU].

To return to the menu above the current one

Press [RETURN].

To change the menu background

Press [OSD/DISPLAY].

The background changes to the one recorded on the disc.

Selecting from the lists

While playing

1 Press [MENU].

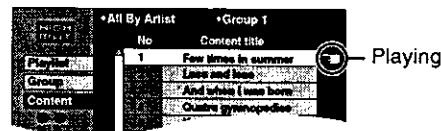

2 Press [◀] then [▲, ▼] to switch between the play list, group and content lists.

3 Press [▶] then [▲, ▼] to select an item and press [ENTER].

To exit the list screen

Press [MENU].



HighMAT and the HighMAT logo are either trademarks or registered trademarks of Microsoft Corporation in the United States and/or other countries.



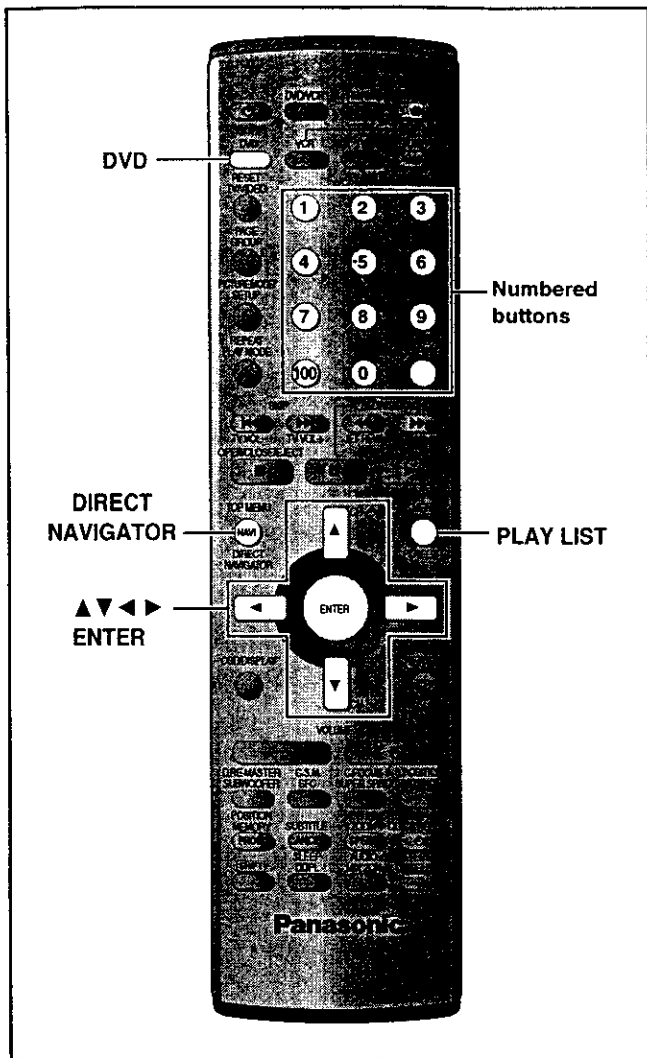

RAM

Selecting a program to play —DIRECT NAVIGATOR

Use the program list to find programs to play.

- 1 Press [DIRECT NAVIGATOR].

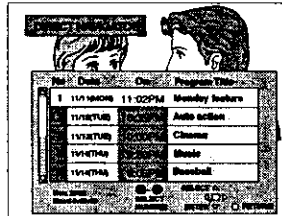

- Titles appear only if you have entered them.
- You cannot change program and disc titles.

- 2 Press [▲, ▼] to select the program.

The selected program plays in the background.

- You can select programs with the numbered buttons.
To select a 2-digit number
e.g. 23: [≧10] → [2] → [3]

- 3 Press [ENTER].

The program being played in the background continues.

To clear the program list
Press [DIRECT NAVIGATOR].

Playing a play list

You can play a group of scenes, a play list, created on other equipment such as a DVD video recorder.

- 1 Press [PLAY LIST].

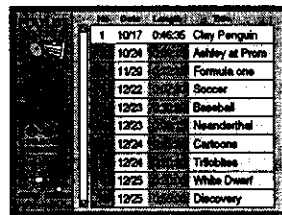

- 2 Press [▲, ▼] to select the play list.

- You can select play lists with the numbered buttons.
To select a 2-digit number
e.g. 23: [≧10] → [2] → [3]

- 3 Press [ENTER] to start play.

To clear the play list screen
Press [PLAY LIST].

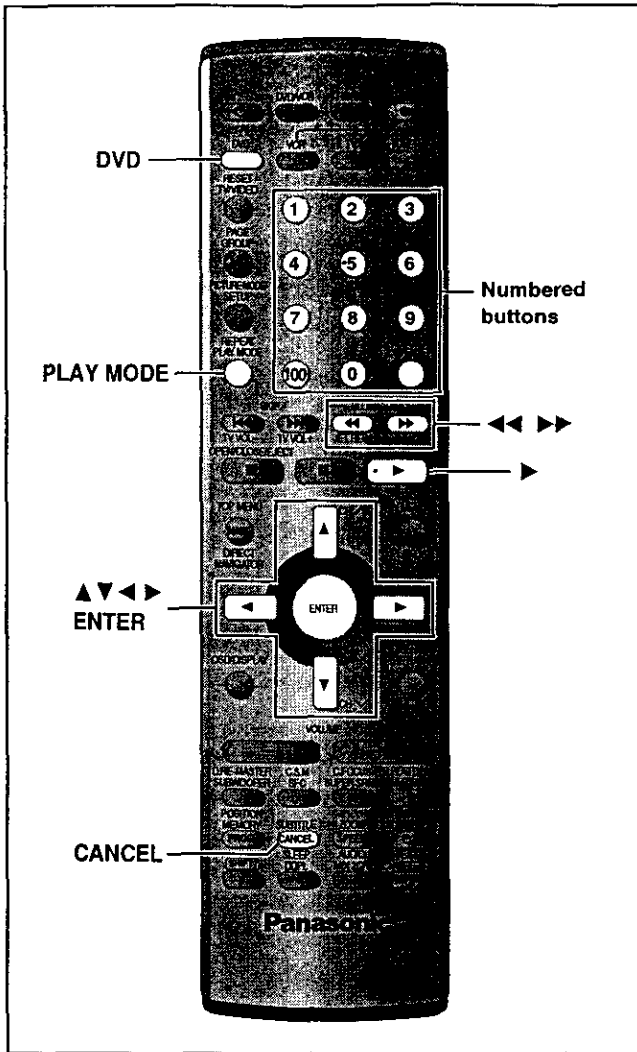

DVD-A DVD-V VCD CD WMA MP3

Common procedures for All group, Random and Program play

While stopped
Press [PLAY MODE].

Each time you press the button:
All group (DVD-A) → Program → Random
↑ Off (Normal play) ↓

DVD-A
If you select bonus groups, you will have to enter a password (→ page 20).

Note
Disable HighMAT disc play to use random and program play.
1. In the SETUP menu, set "HighMAT" to "Disable" (→ page 31).
2. Reinsert the disc and perform the necessary operations.

All group play

DVD-A
The unit plays tracks in all the groups on a disc.

Press [▶] (play).

Program play

You can select up to 24 items to play in the order you choose.
e.g. DVD-V

1 Press the numbered buttons to select a group, title, track, or chapter

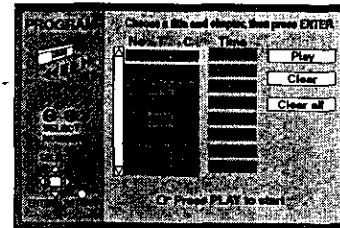

(WMA MP3 then press [ENTER]).

Repeat this step to program other items.

- To select an item using the cursor buttons
Press [ENTER] and [▲, ▼] to select an item, then press [ENTER] again to register.
All the items in the selected disc, title or group are selected when you select "ALL".

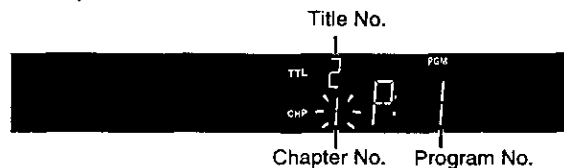

2 Press [▶] (play).

Changing the program

- Press [▲, ▼] to select an item.
- To change an item, repeat step 1.
- To clear an item, press [CANCEL] (or select "Clear" and press [ENTER]).
- Press [◀, ▶] to skip 8 lines at a time.

To clear the whole program

Select "Clear all" with [▲, ▼, ◀, ▶] and press [ENTER].

Note

- The program is cleared when you switch the unit to standby, open the disc tray, select another source.
- DVD-V WMA MP3
Times are not displayed while programming.

Random play

1 DVD-A DVD-V
Press the numbered buttons to select a group or a title.

- You can select more than one group. To enter all groups, select "All" using [◀, ▶] and press [ENTER].
- To deselect a group, press the numbered buttons corresponding to the group you want to clear.

e.g. DVD-V



2 Press [▶] (play).



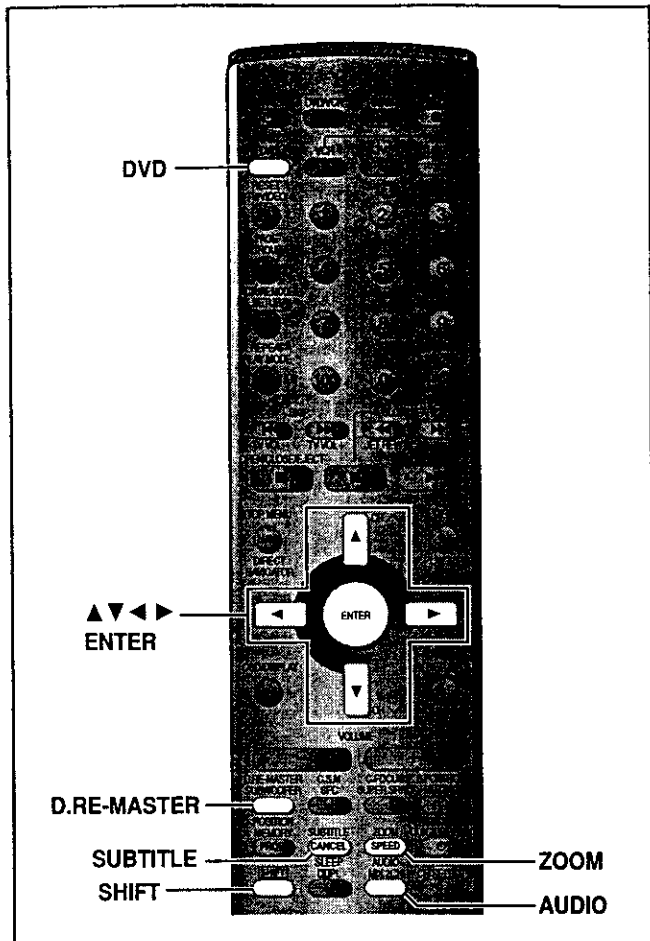

Soundtracks

RAM DVD-A DVD-V VCD

During play
Press [SHIFT]+[AUDIO].

RAM VCD

Each time you do this:

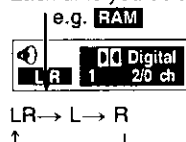

DVD-A

Soundtrack playing



Soundtrack selected

DVD-V

The number changes each time you do this:

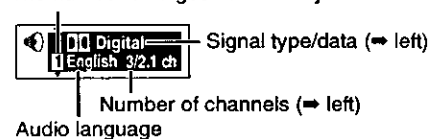

- You can also use this button to turn the vocals on and off on karaoke discs. Read the disc's instructions for details.
- Play restarts from the beginning of the soundtrack when playing DVD-Audio and DVD-RAM soundtracks that are accompanied by still pictures.
- Even if a second soundtrack isn't recorded on a DVD-Audio, two soundtrack numbers will normally be shown. The soundtrack currently playing is number 1.

Subtitles

DVD-A (Motion picture parts only) DVD-V:

You can change the subtitle language and turn the subtitles on and off.

RAM: You can turn the subtitles on and off.

During play
Press [SHIFT]+[SUBTITLE].

The number changes each time you do this.

e.g. DVD-V

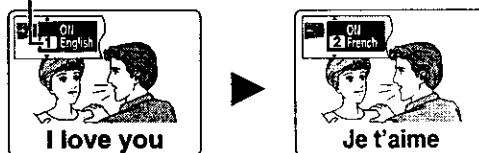

- In some cases, the subtitle language is not changed to the selected one immediately.
- Refer to "Audio/Subtitle language" (⇐ page 29) for language abbreviations.
- If the subtitles overlap closed captions recorded on discs, turn the subtitles off.

To clear/display the subtitles

- 1 Press [SHIFT]+[SUBTITLE].
- 2 Press [▶]. (DVD-A DVD-V)
- 3 Press [▲, ▼] to select "OFF" or "ON".

Changing the position and brightness of the subtitles (DVD-A DVD-V)

- 1 While the subtitle icon is on the screen, press [◀, ▶] to highlight "Subtitle Position" or "Subtitle Brightness".
- 2 Press [▲, ▼] to adjust.



Subtitle position
Subtitle brightness

- Adjust position between 0 and -60 in 2 unit steps.
- For brightness, select "Auto" so the brightness adjusts automatically against the background, or a level between 0 and -9.

"—" or "--" is displayed instead of the language number in circumstances such as when no language is recorded on the disc.

Signal type/data

LPCM/PPCM/Digital/DTS: Signal type

k (kHz): Sampling frequency

b (bit): Number of bits

ch (channel): Number of channels

Example:

3/2 .1ch

.1: Low frequency effect
(not displayed if there is no signal)

0: No surround

1: Mono surround

2: Stereo surround (left/right)

1: Center

2: Front left+ Front right

3: Front left+ Front right+ Center

Variable Zoom function

RAM DVD-A (Motion picture parts only) **DVD-V VCD**

Change the zoom ratio so the picture expands to the optimum size to fill the screen.

Preparation

Change the setting "TV Aspect" to suit your television (⇒ page 31).

During play

Press **[ZOOM]** to select the preset aspect ratio.



The zoom ratio changes each time you press the button.

Zoom - 4:3 Standard

The popup shows the video format suited to the ratio.

Each time you press the button:

4:3 Standard → European Vista → 16:9 Standard

Cinemascope2 ← Cinemascope1 ← American Vista

• Refer to the disc's instructions and "Screen size" below for the aspect ratio of the picture.

To restore the original ratio

Press **[ZOOM]** until the ratio returns to 1.00.

- The ratio also returns to 1.00 when you open the disc tray, change the source or switch the unit to standby.
- The ratio may return to 1.00 when a menu is displayed.

Making fine adjustments to the zoom ratio

While the ZOOM icon is displayed

Press **[▲, ▼]**.

The ratio changes in 0.01 units between 1.00 and 1.60 and in 0.02 units between 1.60 and 2.00.

Screen size

Movies are made using a variety of screen sizes.

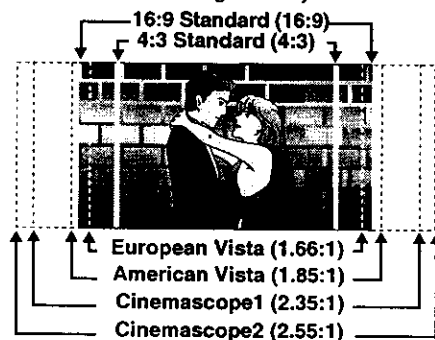

Double re-master—Enjoying more natural sound

RAM DVD-A DVD-V CD

Discs recorded with 2-channel LPCM at 44.1 kHz or 48 kHz

This feature gives you a more natural sound by adding the higher frequency signals not recorded on the disc.

WMA MP3

Discs recorded at 44.1 kHz or 48 kHz

This feature reproduces the frequencies lost during recording to give you a sound closer to the original.

During play

Press **[SHIFT]+[D.RE-MASTER]**.



Output sampling frequency

Each time you press the button:

Setting	RAM DVD-A DVD-V CD Type of music	WMA MP3 Effect level
1	High tempo (e.g., pops and rock)	Light
2	Various tempos (e.g., jazz)	Medium
3	Low tempo (e.g., classical)	Strong
OFF	Off	Off



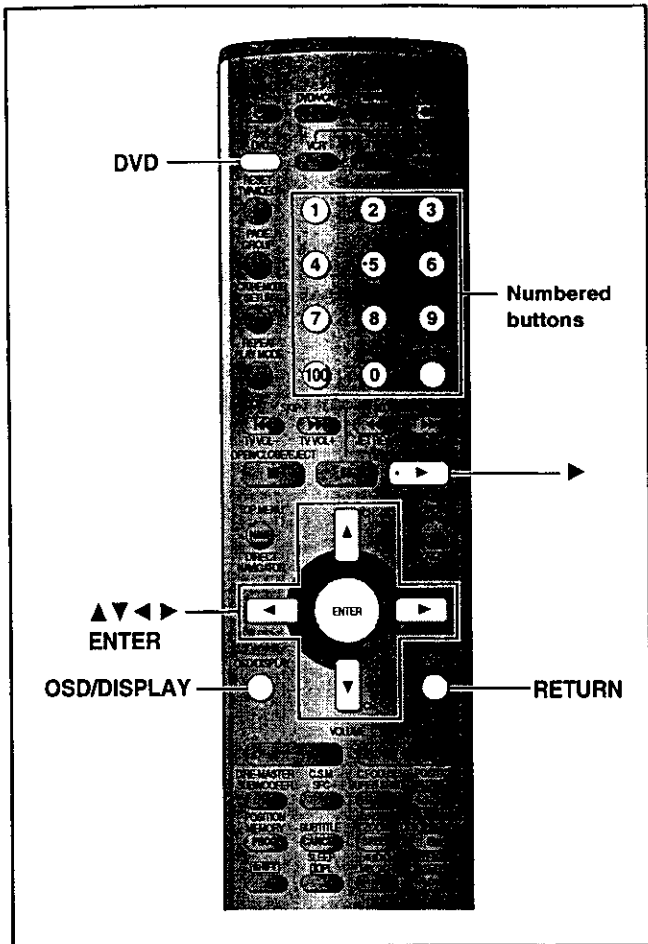

- Change items with "▲" or "▼" above and below with [▲, ▼] (press [ENTER] if the setting doesn't change).
- Change numbered items with the numbered buttons and press [ENTER].
- Read the following explanations for other items.
- Depending on the condition of the unit (playing, stopped, etc.) and the type of software, there are some items that you cannot select or change.

To clear the menus

Press [RETURN] until the menus disappear.

To change the position of the icons

- 1 Press [◀, ▶] to select the rightmost icon.
- 2 Press [▲, ▼] to move the icons. (There are 5 positions.)



Progress indicator

Indicates how far you have played through an item.

e.g. DVD-V

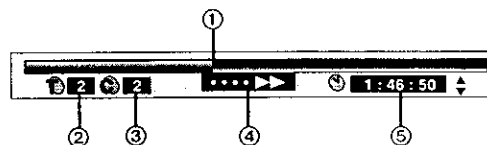

- ① Current position **RAM DVD-A DVD-V VCD CD WMA MP3**
- ② PG: Program number **RAM**
PL: Play list number **RAM**
T: Title number **DVD-V**
Track number **VCD CD**
- ③ G: Group number **DVD-A WMA MP3 JPEG**
T: Track number in group **DVD-A WMA MP3**
C: Chapter number **DVD-V**
P: Picture number **JPEG**
- ④ Condition – play, pause, or slow/search
RAM DVD-A DVD-V VCD CD WMA MP3
Play speed (⇒ below)
- ⑤ Changing the time display **RAM DVD-A DVD-V VCD CD**
Press [▲, ▼] to show the elapsed play time or remaining time for the program, play list, track or title (or chapter during program and random play).
Elapsed play time **WMA MP3**
(display only, cannot be changed)

RAM DVD-A DVD-V VCD CD WMA MP3 JPEG

On-Screen Menu Icons contain information about the disc or unit. These menus allow you to perform operations by changing this information.

Common procedures

1 Press [OSD/DISPLAY].

Each time you press the button:

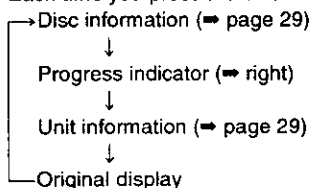

2 [Unit information only]

While the leftmost icon is highlighted

Press [▲, ▼] to select the menu.

Each time you press the button:

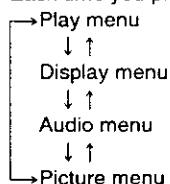

3 Press [◀, ▶] to select the item.

4 Press [▲, ▼] to select the setting.

Changing play speed

DVD-A (Motion picture part)

DVD-V (Dolby Digital only)

You can slow down or speed up play.

During play

Press [◀] (slower) or [▶] (faster).

There are five speeds:

×0.8 ↔ ×0.9 ↔ ×1.0 (normal speed) ↔ ×1.2 ↔ ×1.4

After you change the speed, output is in stereo.

Sound is stereo as long as "×1.0" is orange.

To return to normal play (surround sound), press [▶] (play).

Normal play is also restored when you return the speed to ×1.0 and clear the progress indicator.

Unless otherwise indicated, select items with [◀, ▶] and change with [▲, ▼].

Disc information

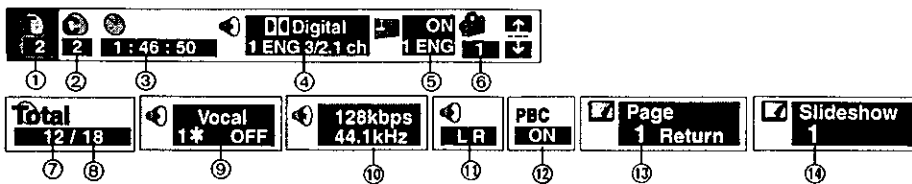

①	PG: Program number RAM PL: Play list number RAM G: Group number DVD-A WMA MP3 JPEG T: Title number DVD-V Track number VCD CD	[▲, ▼] ↓ [ENTER]
②	T: Track number in group DVD-A WMA MP3 C: Chapter number DVD-V P: Picture number in group JPEG	[ENTER]
③	Time RAM DVD-A DVD-V Select a position to start play by specifying a time. Changing the time display RAM DVD-A DVD-V VCD CD WMA MP3 (Display only) → Elapsed play time for the program, play list, title or track ↓ ↑ Remaining time for the group (DVD-A) or disc (VCD CD) ↓ ↑ Remaining time for the program, play list, title or track	Numbered buttons ↓ [ENTER]
④	Soundtrack DVD-A DVD-V (⇒ page 26)	
⑤	Subtitle language DVD-A DVD-V (⇒ page 26) Subtitles on/off RAM DVD-A DVD-V Track information on/off WMA MP3 CD (CD text only) Picture information JPEG Full: Group title, picture title, picture size, file size, date of shooting, and camera model used*. Date: Date of shooting only. OFF: No display. * Actual displays depend on the camera and data.	
⑥	Angle number DVD-A DVD-V Picture rotation JPEG 0 ↔ 90 ↔ 180 ↔ 270 ↑	

⑦	Track/picture number in disc WMA MP3 JPEG	[▲, ▼] ↓ [ENTER]
⑧	Total number of tracks/pictures on disc WMA MP3 JPEG	Display only
⑨	Karaoke vocal on/off DVD-V (Karaoke DVD only) If a DVD title is a duet, select V1 or V2 to duet with the unit.	
⑩	Current bitrate (kbps) Current sampling frequency (kHz) WMA MP3	Display only
⑪	Audio mode RAM VCD LR → L → R ↑	
⑫	Menu play VCD (with playback control only)	Display only
⑬	Still picture number DVD-A • To return to page 1 [◀, ▶] → Select "Return" → [ENTER]	
	Slideshow DVD-A Picture number	Display only
⑭	Slideshow setting JPEG ON ↔ OFF Slideshow timing JPEG 0 - 30 sec	



Audio/Subtitle language

ENG: English	SVE: Swedish	CHI: Chinese
FRA: French	NOR: Norwegian	KOR: Korean
DEU: German	DAN: Danish	MAL: Malay
ITA: Italian	POR: Portuguese	VIE: Vietnamese
ESP: Spanish	RUS: Russian	THA: Thai
NLD: Dutch	JPN: Japanese	*: Others

Unit information

Play menu



①	A-B repeat (⇒ page 21) RAM DVD-A DVD-V VCD CD WMA MP3	[ENTER]
②	Repeat mode (⇒ page 21) RAM DVD-A DVD-V VCD CD WMA MP3 JPEG	
③	Play mode (⇒ page 25) DVD-A DVD-V VCD CD WMA MP3 ---: Normal play PGM: Program play RND: Random play ALL: All group play (DVD-A)	Display only
④	Marker RAM DVD-A DVD-V VCD CD WMA MP3 JPEG	⇒ page 21

Audio menu



①	Double re-master (⇒ page 27) RAM DVD-A DVD-V CD WMA MP3	
②	Dialogue Enhancer on/off DVD-V (Discs where the dialogue is recorded in the center channel) This makes the dialogue in movies easier to hear.	

Unit information

Display menu

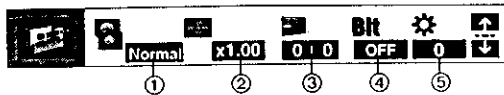

①	<p>4:3 Aspect RAM DVD-A DVD-V VCD JPEG Select how to show images made for 4:3 aspect screens on a 16:9 aspect television.</p> <ul style="list-style-type: none"> ● Normal: Laterally stretches images made for a 4:3 screen. ● Auto: Expands suitable 4:3 letterbox images to fill more of the screen. Other images appear in full in the center of the screen. ● Shrink: Images appear in the center of the screen. ● Zoom: Expands all images to fill the screen. <p>If your television has a similar feature, use it instead for a better effect.</p>
②	<p>Zoom (⇒ page 27) RAM DVD-A DVD-V VCD To select preset aspect ratio Press [ENTER] and then [◀, ▶] to select. Press [ENTER] to finish.</p> <p>Making fine adjustments to the zoom ratio [▲, ▼]</p>
③	<p>Subtitle position/Subtitle brightness (⇒ page 26) DVD-A DVD-V</p>
④	<p>Bitrate display on/off RAM DVD-A (Motion picture parts only) DVD-V VCD</p> <p>During play: shows the average bitrate (approximate values) of the video being played While paused: shows the data volume of the frame and type of picture (⇒ page 59, Glossary—I/P/B)</p> <div style="border: 1px solid black; padding: 5px; margin: 10px 0;"> <p style="text-align: center;">9.438 Mbps ▶</p> <p style="text-align: center;">↑ [◀, ▶]</p> <div style="border: 1px solid black; padding: 2px;"> <p style="text-align: center;">Bitrate</p> <p style="text-align: center;">Cur. 7.507 Mbps</p> <p style="text-align: center;">Ave. 6.730 Mbps</p> <p style="text-align: right;">5.0 Mbps</p> </div> <p style="text-align: center;">Current bitrate A record of bitrates for a sampling period.</p> <p style="text-align: center;">Average bitrate</p> </div>
⑤	<p>OSD brightness (–3 to +3) Adjust the brightness of the on-screen displays.</p>

Picture menu

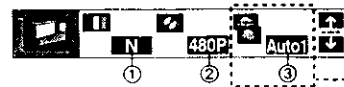

----- When progressive output is on

①	<p>Picture mode RAM DVD-A DVD-V VCD JPEG</p> <ul style="list-style-type: none"> ● N: Normal mode ● S: Soft mode (Soft picture with fewer video artifacts) ● F: Fine mode (Details are sharper) ● C1: Mellows images and enhances detail in dark scenes ● C2: Sharpens images and enhances detail in dark scenes ● U1/U2: User mode (⇒ below)
②	<p>Video output mode RAM DVD-A DVD-V VCD JPEG</p> <ul style="list-style-type: none"> ● 480i: Interlace video ● 480P: Progressive video
③	<p>Transfer mode RAM DVD-A DVD-V VCD</p> <p>Select the method of conversion for progressive output to suit the type of material being played.</p> <ul style="list-style-type: none"> ● Auto 1 (normal): for viewing film material ● Auto 2: for viewing film material (the same as Auto 1, but able to convert 30-frame-per-second progressive video) ● Video: for video material

To change the user mode

- 1 Select User mode and press [▶] to highlight the number.
- 2 Press [▲, ▼] to select "1" or "2".

U1

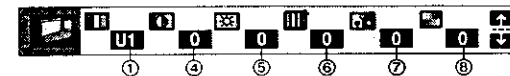

④	<p>Contrast (–7 to +7) Increases the contrast between light and dark parts of the picture.</p>
⑤	<p>Brightness (0 to +15) Brightens the picture.</p>
⑥	<p>Sharpness (–7 to +7) Adjusts the sharpness of the edges of the horizontal lines.</p>
⑦	<p>Color (–7 to +7) Adjusts the shade of the picture's color.</p>
⑧	<p>Gamma (0 to +5) Adjusts the brightness of dark parts of the picture.</p>

U2

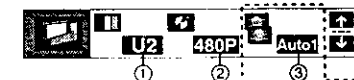





----- When progressive output is on
 ①–③ (⇒ above)



This chart shows the settings for this unit. Change the settings to suit your preferences and to suit the unit to the environment in which it is being used. These settings are retained in memory until they are changed, even if the unit is turned off. See page 32 for details on menu operation.

• Underlined items are the factory preset.

Menus	Items	Options
 <p>Disc</p>	<p>Audio Choose the preferred audio language.</p>	<p><u>English</u> French Spanish Original Other **** Original: The original language of each disc will be selected. Other ****: input a code number with the numbered buttons (⇒ page 32).</p>
	<p>Subtitle Choose the preferred subtitle language.</p>	<p><u>Automatic</u> English French Spanish Other **** Automatic: If the language selected for "Audio" is not available, subtitles of that language will automatically appear if available on that disc.</p>
	<p>Menus Choose the preferred language for disc menus.</p>	<p><u>English</u> French Spanish Other ****</p>
	<p>Ratings (⇒ page 33) Set a ratings level to limit DVD-Video play. • The password screen is shown if you choose levels 0 to 7 or if you choose "Ratings" when levels 0 to 7 have been selected. • Select "Level 0" to prevent play of discs that do not have ratings levels recorded on them.</p>	<p>Setting ratings (When level 8 is selected) <u>8 No Limit</u>: All DVD-Video can be played. 1 to 7: Prohibits play of DVD-Video with corresponding ratings recorded on them. 0 Lock All: Prohibits play of all DVD-Video.</p> <hr/> <p>Changing ratings (When level 0–7 is selected) Unlock Player Change Level Change Password Temporary Unlock</p>
 <p>Video</p>	<p>TV Aspect (⇒ page 17) Choose the setting to suit your television and preference.</p>	<p><u>4:3 Pan&Scan</u> 4:3 Letterbox 16:9</p>
	<p>TV Type (⇒ page 17) Select to suit the type of television.</p>	<p><u>Standard (Direct View TV)</u> CRT Projector LCD TV/Projector Projection TV Plasma TV</p>
	<p>Still Mode Specify the type of picture shown when paused.</p>	<p><u>Automatic</u> Field Frame</p>
	<p>Black Level Control Change the black level of the picture if you connected a television through the COMPONENT VIDEO OUT terminals.</p>	<p><u>Lighter</u>: When connected to a TV through the VIDEO OUT or S-VIDEO OUT terminal. <u>Darker</u>: When connected to a TV through the COMPONENT VIDEO OUT (Y/Pa/Pa) terminals.</p>
 <p>Audio</p>	<p>Speaker Setting (⇒ page 33) Set the delay time for your center and surround speakers.</p>	<p>Multi-channel Center: 0/1.3/2.6/3.9/5.3 ms Surround (L/R): 0/5.3/10.6/15.9 ms</p>
	<p>Dynamic Range Compression (Dolby Digital only) Change the dynamic range for late night viewing.</p>	<p><u>Off</u> On: For clear dialog when listening at low volume.</p>
	<p>Audio during Search Choose whether to have sound during search.</p>	<p><u>On</u> Off This feature doesn't work for some discs.</p>
 <p>Display</p>	<p>Menu Language Choose the preferred language for these menus and the on-screen messages.</p>	<p><u>English</u> Français Español</p>
	<p>On-Screen Messages Choose whether to show on-screen messages or not.</p>	<p><u>On</u> Off</p>
 <p>Others</p>	<p>HighMAT Play HighMAT discs as HighMAT discs, or as regular WMA/MP3/JPEG discs. (Reload the disc for the setting to be effective.)</p>	<p><u>Enable</u>: Play HighMAT discs as HighMAT discs. Disable: Play HighMAT discs as regular WMA/MP3/JPEG discs.</p>
	<p>Mixed Disc—Audio & Stills Select the type of file played on discs containing both JPEG and WMA/MP3. (Reload the disc for the setting to be effective.)</p>	<p><u>Audio (MP3/WMA)</u> Stills (JPEG)</p>
	<p>DVD-Video Mode Select how to play pictures contained on some DVD-Audio. The setting returns to "Off" when you remove the disc, turn the unit off or change the source.</p>	<p><u>Off</u>: DVD-Audio are played as DVD-Audio. On: You can play DVD-Video content on DVD-Audio.</p>
	<p>QUICK SETUP (⇒ page 17) Answer questions to make basic settings.</p>	<p>Yes (Menu language, Audio language, Subtitle language, TV type, TV aspect) <u>No</u></p>



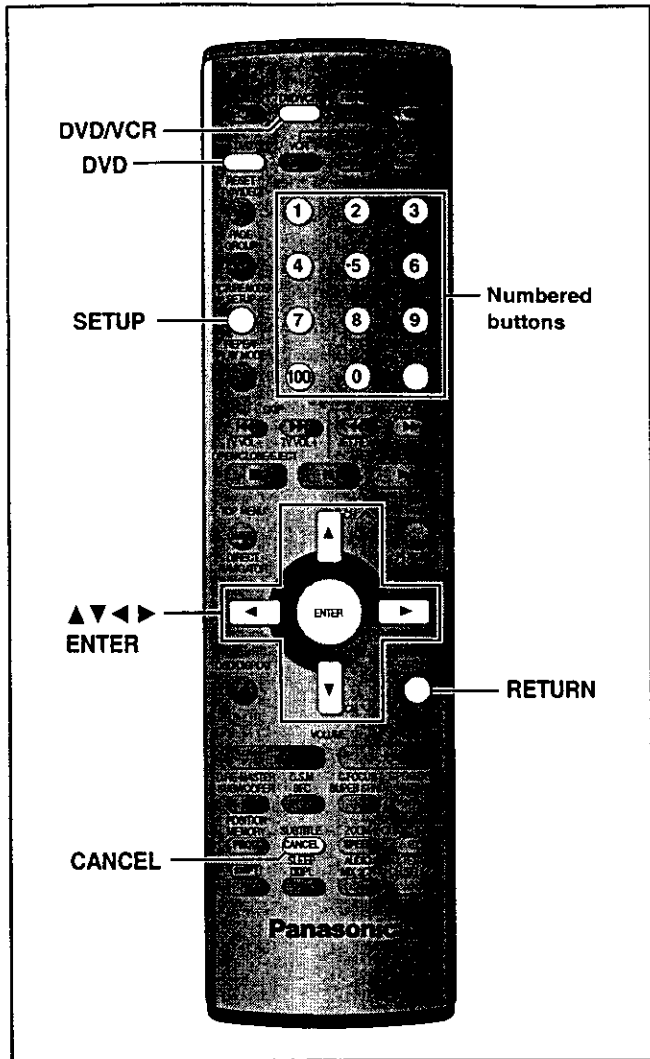

Common procedures

See page 31 for menu and option details.

Preparation

- Press [DVD] to put the remote control in DVD mode.
- Press [DVD/VCR] to select "DVD" as the source.

1 Press [SETUP] to show the menus.

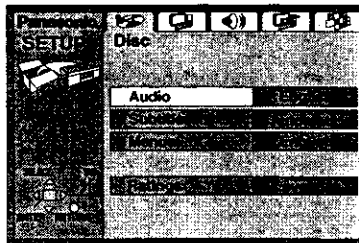

2 Press [◀, ▶] to select the menu's tab.

The screen changes to display the menu.

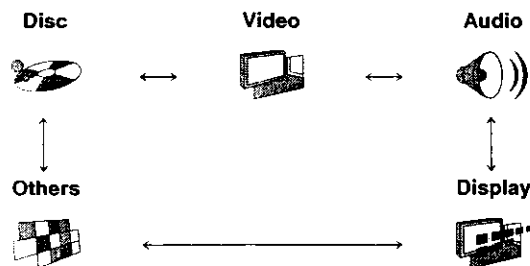

3 Press [▲, ▼] to select the item you want to change and press [ENTER].

4 Press [▲, ▼, ▶, ◀] to select the option and press [ENTER].

The screen now shows the menu again.

To return to the previous screen

Press [RETURN].

When you are finished

Press [SETUP].

Language code list

Abkhazian: 6566	Chinese: 9072	Hausa: 7265	Lithuanian: 7684	Romanian: 8279	Telugu: 8469
Afar: 6565	Corsican: 6779	Hebrew: 7387	Macedonian: 7775	Russian: 8285	Thai: 8472
Afrikaans: 6570	Croatian: 7282	Hindi: 7273	Malagasy: 7771	Samoan: 8377	Tibetan: 6679
Albanian: 8381	Czech: 6783	Hungarian: 7285	Malay: 7783	Sanskrit: 8365	Tigrinya: 8473
Ameharic: 6577	Danish: 6865	Icelandic: 7383	Malayalam: 7776	Scots Gaelic: 7168	Tonga: 8479
Arabic: 6582	Dutch: 7876	Indonesian: 7378	Maltese: 7784	Serbian: 8382	Turkish: 8482
Armenian: 7289	English: 6978	Interlingua: 7365	Maori: 7773	Serbo-Croatian: 8372	Turkmen: 8475
Assamese: 6583	Esperanto: 6979	Irish: 7165	Marathi: 7782	Shona: 8378	Twi: 8487
Aymara: 6588	Estonian: 6984	Italian: 7384	Moldavian: 7779	Sindhi: 8368	Ukrainian: 8575
Azerbaijani: 6590	Faroese: 7079	Japanese: 7465	Mongolian: 7778	Singhalese: 8373	Urdu: 8582
Bashkir: 6665	Fiji: 7074	Javanese: 7487	Nauru: 7865	Slovak: 8375	Uzbek: 8590
Basque: 6985	Finnish: 7073	Kannada: 7578	Nepali: 7869	Slovenian: 8376	Vietnamese: 8673
Bengali; Bangla: 6678	French: 7082	Kashmiri: 7583	Norwegian: 7879	Somali: 8379	Volapük: 8679
Bhutani: 6890	Frisian: 7089	Kazakh: 7575	Oriya: 7982	Spanish: 6983	Welsh: 6789
Bihari: 6672	Galician: 7176	Kirghiz: 7589	Pashto, Pushto: 8083	Sundanese: 8385	Wolof: 8779
Breton: 6682	Georgian: 7565	Korean: 7579	Persian: 7065	Swahili: 8387	Xhosa: 8872
Bulgarian: 6671	German: 6869	Kurdish: 7585	Polish: 8076	Swedish: 8386	Yiddish: 7473
Burmese: 7789	Greek: 6976	Laotian: 7679	Portuguese: 8084	Tagalog: 8476	Yoruba: 8979
Byelorussian: 6669	Greenlandic: 7576	Latin: 7665	Punjabi: 8065	Tajik: 8471	Zulu: 9085
Cambodian: 7577	Guarani: 7178	Latvian, Lettish: 7686	Quechua: 8185	Tamil: 8465	
Catalan: 6765	Gujarati: 7185	Lingala: 7678	Rhaeto-Romance: 8277	Tatar: 8484	

Entering a password (Ratings)

DVD-V

The password screen is shown when you select levels 0 to 7.

- Input a 4-digit password with the numbered buttons and press [ENTER].
 - If you enter a wrong number, press [CANCEL] to erase it before you press [ENTER].
 - The lock symbol appears closed to show the rating is locked.
 - Do not forget your password.**
- Press [ENTER] to confirm the 4 digits.

Now, when you insert a DVD-Video that exceeds the ratings limit you set, a message appears on the television. Follow the on-screen instructions.

Changing the delay time (Speaker Setting)

(Effective when playing multi-channel discs)

For optimum listening with 5.1-channel sound, all the speakers, except for the subwoofer, should be the same distance from the seating position. If you have to place the center or surround speakers closer to the seating position, adjust the delay time to make up for the difference.

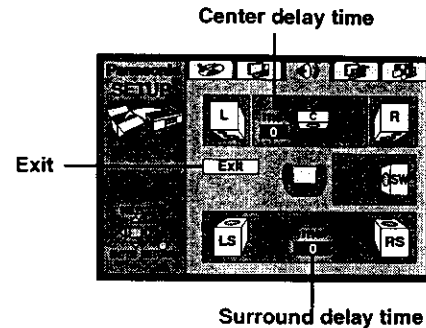

- Press [▲, ▼, ◀, ▶] to select the delay time box and press [ENTER].
- Press [▲, ▼] to adjust the delay time and press [ENTER].

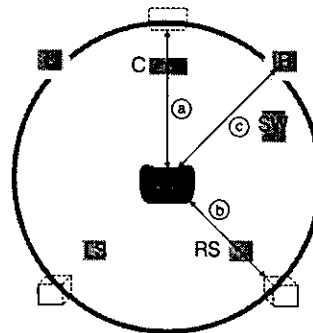

Values

If distance (a) or (b) is greater than or equal to distance (c), set to "0".
If distance (a) or (b) is less than distance (c), set as follows.

Ⓐ Center speaker

Difference	Setting
Approx. 50 cm (1½ feet)	1.3 ms
Approx. 100 cm (3 feet)	2.6 ms
Approx. 150 cm (5 feet)	3.9 ms
Approx. 200 cm (6 feet)	5.3 ms

Ⓑ Surround speakers

Difference	Setting
Approx. 200 cm (6 feet)	5.3 ms
Approx. 400 cm (12 feet)	10.6 ms
Approx. 600 cm (18 feet)	15.9 ms

When you are finished

Press [▲, ▼, ◀, ▶] to select "Exit" and press [ENTER].



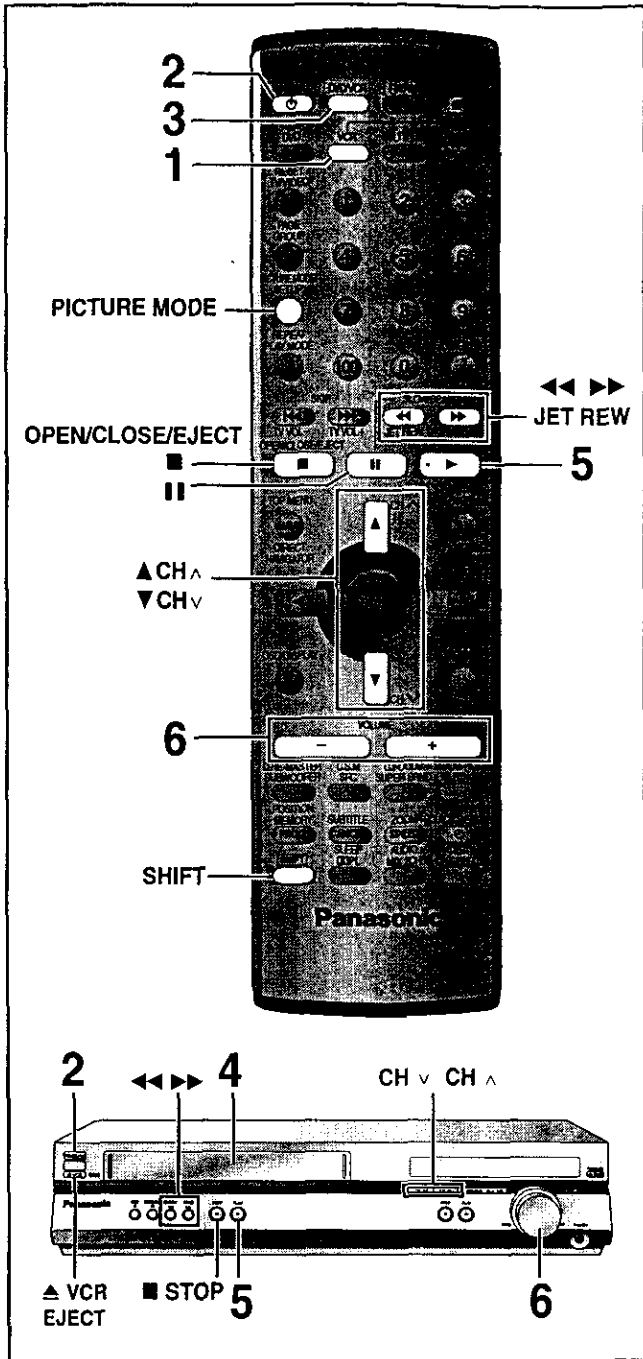

Preparation

Turn on the television and select the video input for the VCR.

- 1 Press [VCR] to put the remote control in VCR mode.
- 2 Press [⏻] to turn on the unit.
- 3 Press [DVD/VCR] to select "VCR" as the source.

The following indicator appears when you select VCR.



- 4 Insert a tape.

Play starts automatically if you insert a prerecorded tape or one that has had its tab removed.

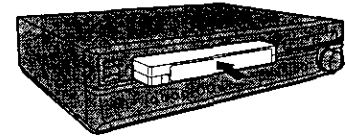

- 5 Press [▶] (play).
- 6 Adjust the volume.

Stop	Press [■].
Fast-forward and rewind	While stopped, press [◀◀] (backward) or [▶▶] (forward).
Jet rewind	While stopped, press [SHIFT]+[◀◀ JET REW].
Cue and review	During play, press [◀◀] (backward) or [▶▶] (forward). Or Press and hold during play. Play restarts when you release the button.
Jet search	During play, press [◀◀] (backward) or [▶▶] (forward) twice.
Pause	Press [⏸]. Press [⏸] or [▶] (play) to restart.
Slow	Press and hold [⏸] for about two seconds.
Eject	Press [▲ VCR EJECT] on the main unit or [SHIFT]+[OPEN/CLOSE/EJECT] on the remote control.

Note

- Press [▶] (play) to restart play.
- You can fast-forward and rewind while using another source.
- The tape counter does not appear during Jet rewind.
- The tape moves at high speed during fast-forward, rewind, and jet rewind so the unit will make a noise. Also, it takes some time for the tape to stop after you press [■].
- There is no sound during cue, review, jet search, pause, and slow.
- Cue, review, jet search, and slow stop after 10 minutes and pause after 5 minutes.
- The picture during cue, review, and jet search may be disrupted or otherwise affected on some televisions. During jet search at 35 times normal speed through EP or VP recordings, the picture may scroll vertically with some televisions. Change to 27-times normal speed if this occurs (→ page 44).
- You can eject tapes when the unit is in standby mode. It switches back to standby once it ejects the tape.
- You cannot eject tapes when the VCR is in timer recording standby or actually recording.



Picture mode—Changing picture quality

You can change the quality of the picture to suit the material you are playing.

Press [PICTURE MODE].



Each time you press the button:

→ **STANDARD:** for recordings of television program
(Factory preset)

→ **DYNAMIC:** Clear, vivid pictures for scenery and sports

→ **SOFT:** for prerecorded tapes

Repeat play—play a program repeatedly

Press and hold [▶] (play) for about five seconds.

"R▶" appears on the television.

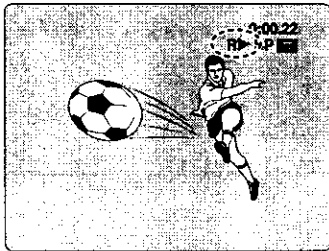

At the end of the program, the tape rewinds to the beginning of the program and plays it again. (It only works if there is a five-second blank at the end of the program.) This repeats until you cancel it.

To cancel

Press [▶] (play).

- It also cancels if you stop, pause, cue, or review.

Manual tracking

This unit has an automatic digital tracking control feature that usually makes tracking adjustments for you, but you may need to do it manually, such as if noise appears on a tape recorded on other equipment.

During play

Press [▲ CH▲] or [▼ CH▼].

Repeat until the noise disappears.

To return to automatic digital tracking control

Press [▲ CH▲] and [▼ CH▼] at the same time.

To remove the noise from a paused picture

Start slow play, then adjust the tracking.

Note

This may not be effective on some tapes.

Vertical locking adjustment

Adjust the vertical to stop the picture jiggling while paused.

While paused

Press [▲ CH▲] or [▼ CH▼].

Repeat until the jiggling stops.

To return to the previous condition

Press [▲ CH▲] and [▼ CH▼] at the same time.

Note

This may not work with some televisions. Try adjusting the vertical on the television itself.



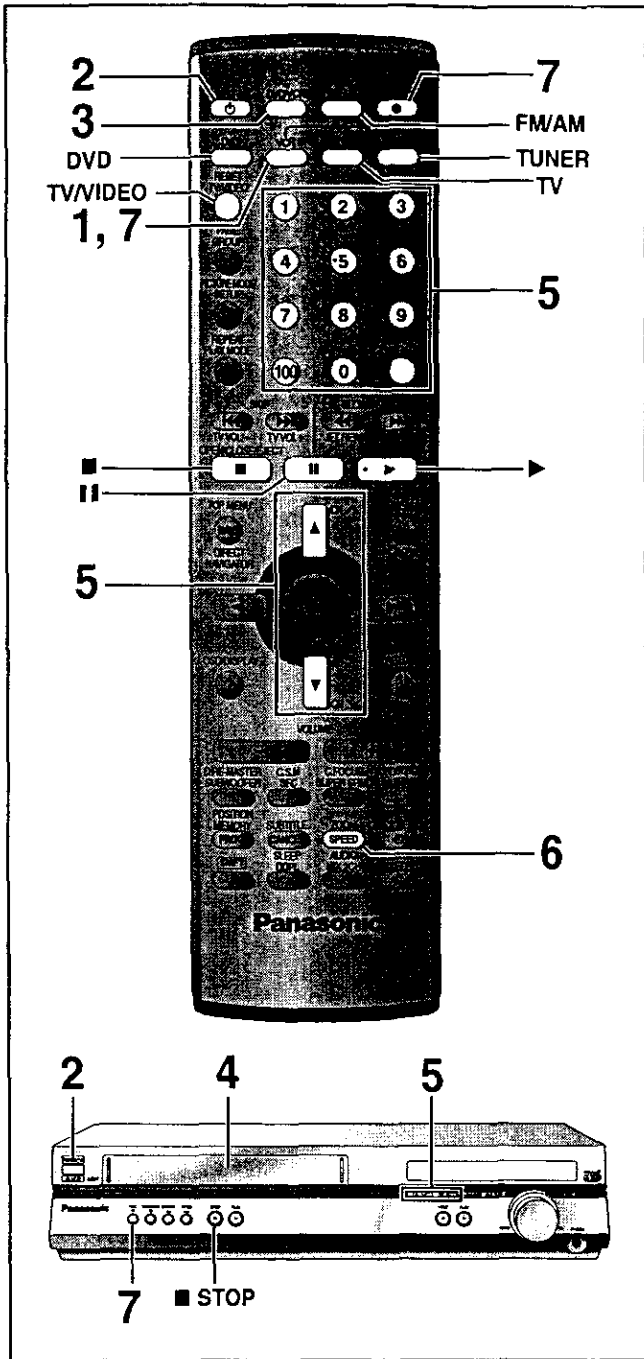

Recording the television

Preparation

Turn on the television and select the video input for the VCR.

- 1** Press [VCR] to put the remote control in VCR mode.
- 2** Press [⏻] to turn on the unit.
- 3** Press [DVD/VCR] to select "VCR" as the source.
- 4** Insert the tape you want to record to.
Ensure its tab is in place (⇒ page 5).
- 5** Select the channel with the numbered buttons or [▲ CH▲], [▼ CH▼].
• To select with the numbered buttons:
e.g. channel 2: [0] ⇒ [2]
channel 23: [2] ⇒ [3]
channel 123: [100] ⇒ [2] ⇒ [3]
- 6** Press [SPEED] to select the tape speed.
Each time you press the button:
SP → EP → VP
- 7** While pressing [VCR], press [● REC] to start recording.
"REC" lights on the unit's display.



To stop recording

Press [■].

To pause recording

Press [⏪].

Press it again or while pressing [VCR], press [● REC] to continue recording.

- To specify a time to stop recording (⇒ page 48, The sleep timer)

Note

- You cannot change channels while recording. You can change channels while paused.
- The unit will automatically return to the stop mode after a pause of 5 minutes while recording.
- Even if the tape you use is labeled "S-VHS", the recordings you make do not use this system.
- You cannot record from the disc section to the VCR.

■ Tape speeds

There are three tape speeds.

SP: You can record the length shown on the tape.

EP: Three times the length of SP mode.

VP: Five times the length of SP mode.

- You cannot play tapes recorded with VP mode on other equipment.
- It takes more time for automatic tracking to work when playing tapes recorded with VP mode, and it may not work at all with some tapes. Do tracking manually if this is the case (⇒ page 35).
- This unit can play tapes recorded with LP mode on other equipment ("LP" lights on the display).

Using another source while recording

You can watch and listen to other content when the unit is in timer recording standby or during VCR recording.

■ Television (⇒ page 16)

- 1 During recording
Press [TV] to put the remote control in TV mode.
- 2 Press [TV/VIDEO] then select the channel with the numbered buttons or [▲ CH▲], [▼ CH▼].

■ DVD (⇒ page 18)

- 1 During recording
Press [DVD] to put the remote control in DVD mode.
- 2 Press [DVD/VCR] to select "DVD".
- 3 Insert a disc and start play.

■ Radio (⇒ page 46)

- 1 During recording
Press [TUNER] to put the remote control in TUNER mode.
- 2 Press [FM/AM] to select the radio band.
- 3 Select the radio channel with the numbered buttons or [▲ CH▲], [▼ CH▼].

Note

When you want to operate the VCR section again, be sure to press [VCR] to put the remote control in VCR mode.

Recording from other equipment

You can record from other video equipment (VCR, camera, etc.)

Preparation

- Connect the equipment to this unit's input terminals.
– Turn the unit off before making connections.
– If audio output on the other equipment is monaural, use a stereo-monaural conversion cable (not included).
- Insert the tape, ensuring its tab is in place and find the place to start recording.

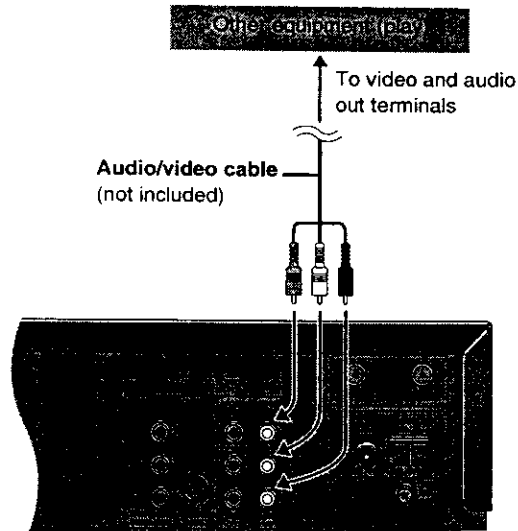

- 1 Press [▲ CH▲] or [▼ CH▼] to select "AU" channel.



- 2 Press [▶] (play) to find the place to start recording.
- 3 Press [||], then while pressing [VCR], press [● REC] to put the unit in recording standby mode.
- 4 Press [SPEED] to select the tape speed.
Each time you press the button:
SP → EP → VP
↑
- 5 Start play on the other equipment.
- 6 Press [||] when you want to start recording.



To stop
Press [■].

- To make a timer program to record from other equipment (⇒ page 38)

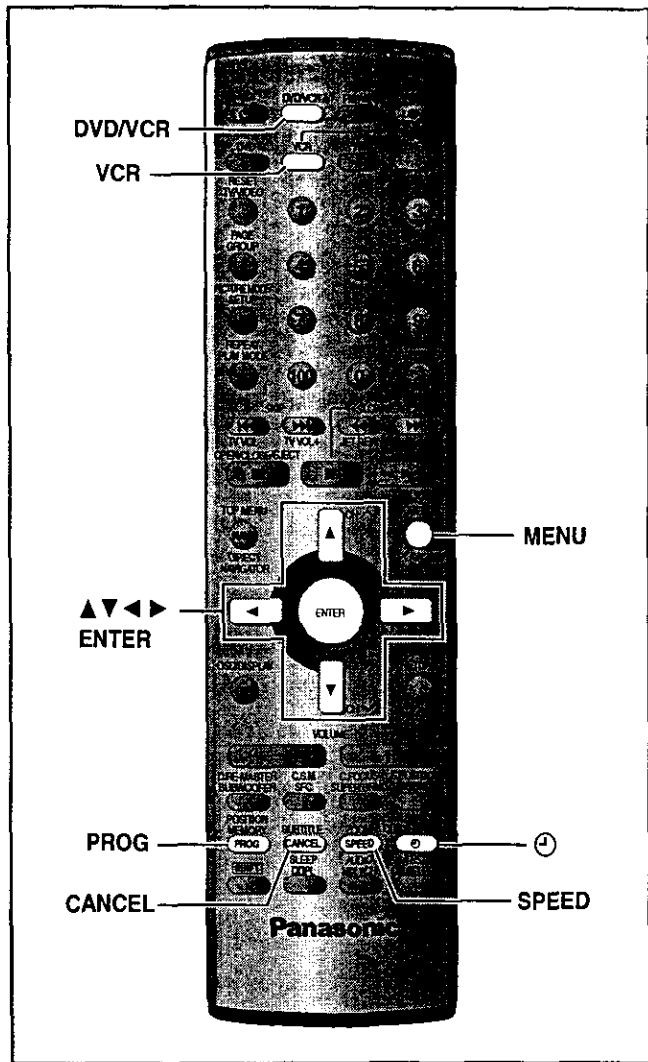

You can create up to 16 timer recording programs. You can set the timer to record an individual program up to a month in advance, record at the same time on the same day every week, or at the same time daily.

Preparation

- Press [VCR] to put the remote control in VCR mode.
- Press [DVD/VCR] to select "VCR" as the source.
- Make sure the unit's clock is correct (⇒ page 42 to adjust it if necessary).
- Insert a tape, ensuring its tab is in place (⇒ page 5).

1 While stopped
Press [PROG].

The timer-programming screen appears.

DATE	CH	ON	OFF	1/2
1 27WE	2	8:02PM	9:30PM	SP
2 28SA	12	8:30PM	11:00PM	A
3 29SU	14	3:00PM	4:00PM	EP
4 19TU	8	8:15PM	11:30PM	VP
5 28TH	AV	8:00PM	0:30PM	SP
6 30SA	4	7:10PM	7:55PM	VP
7				
8				

PROG. ENTER END: MENU

2 Press [PROG] to select an available line and press [ENTER].

3 Select "DATE" with [◀, ▶] and change it with [▲, ▼].

The date changes as follows:

- Current date
- ↓ ↑
- Next day up to one month later minus one day
- ↓ ↑
- Weekly timer: SU-SA → MO-SA → MO-FR
- ↓ ↑
- Daily timer: SU → MO → TU → WE → TH → FR → SA

4 Select "CH" with [◀, ▶] and change it with [▲, ▼].

Select "AU" when recording from other equipment (⇒ page 37).

5 Select "ON" with [◀, ▶] and change the start time with [▲, ▼].

6 Select "OFF" with [◀, ▶] and change the end time with [▲, ▼].

7 Press [SPEED] to change the tape speed.

Each time you press the button:

SP → EP → VP → A*

*Auto SP/EP change function ⇒ page 39

8 If the Jet Navigator is on (⇒ page 40),

Select a category.

Press [▶] to select a category column. Press [▲, ▼] to enter the category selection menu. Then select a category with [▲, ▼, ▶, ▶], and confirm with [MENU].

You can also set and change the category in the navigator list (⇒ page 41).

Repeat steps 2 to 8 to make further timer programs.

9 Press [⊖] to put the unit on timer recording standby.

"⊖" lights on the unit's display.



To release the unit from timer recording standby

Press [⊖].

To stop recording

Press [⊖].

For your reference

The timer works whether the unit is on or not, so you can play DVDs or listen to the radio (⇒ page 37). Switch the unit to standby if you are finished.

To check, correct, and cancel timer programs

To check a program

- Press [PROG].
The timer-programming screen appears.

To correct a program

While the timer programming screen is on the television,

- Press [PROG] to highlight the program you want to correct and press [ENTER].
- Select the item with [◀, ▶] and correct it with [▲, ▼].

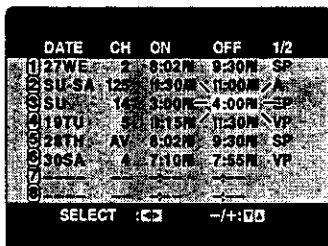

To cancel a program

While the timer programming screen is on the television,

- Press [PROG] to highlight the program you want to cancel.
- Press [CANCEL].

To clear the timer programming screen

Press [MENU].

Auto SP/EP change

The unit switches tape speed to EP if it determines there is not enough tape to record the entire program in SP mode. The change may start at the beginning of the recording or part way through, depending on the remaining tape.

Before using this function, set the length of the tape you are using (→ page 44). It may not work correctly if you use tapes with irregular lengths.

Example program combination

1st program (30 min.)		2nd program (20 min.)
Example program combination		
30 min. at SP	15 min. at SP	15 min. at EP (when using a 60-min. tape)

Note

This function does not guarantee recording of the entire program.



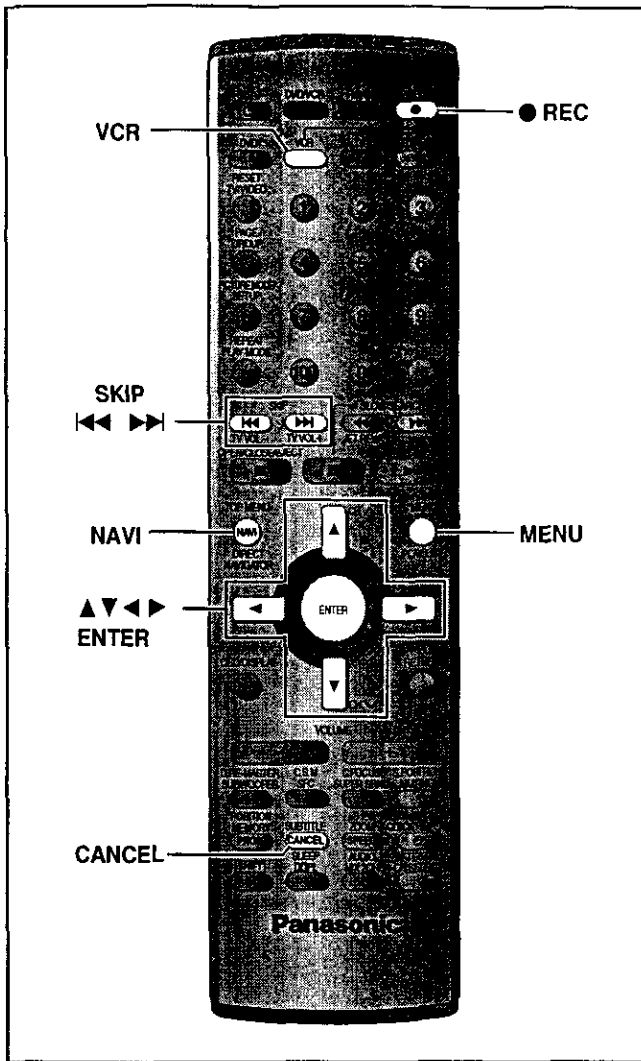

The unit saves the date, channel, time, and category of the recordings you make and shows them on the Jet Navigator list, making it easier to find and play them. It can save the data for up to 14 recordings on a tape, for 20 different tapes, and for a total of 50 recordings.

Saving Jet Navigator data

- 1 Press [MENU] to display the "VCR MENU" screen.
- 2 Press [▲, ▼] to select "OPTION" menu and press [ENTER].
- 3 Press [▲, ▼] to select "JET NAVIGATOR" and press [◀, ▶] to change the setting to "ON".

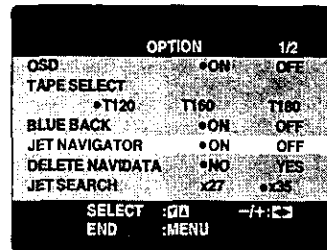

- 4 Press [▲, ▼] to select "TAPE SELECT" and press [◀, ▶] to set the length of the tape you are using.
 T120: T30, T60, T90, T120 tapes
 T160: T140, T160 tapes
 T180: T180 tapes
- 5 Record programs (⇒ pages 36–38).
 The unit makes the list as you record.

Using the Jet Navigator to find programs

- 1 Press [NAVI] to show the "JET NAVIGATOR" screen.
- 2 Press [NAVI] to highlight the program you want to watch.
 The most recent program is highlighted first.

Once you have highlighted the program, wait about three seconds. The VCR then starts searching for the program and starts play.

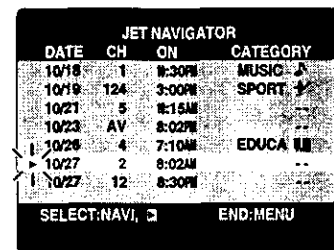

The channel, date, and time of a recording appear on the television when play starts.

To clear the Jet Navigator list
 Press [MENU].

- **To delete the Jet Navigator on a video cassette tape**
 Keep [CANCEL] pressed for more than 5 seconds while the Jet Navigator list appears. "-" appears on the list.
- **To delete all the Jet Navigator data stored in the VCR's memory (⇒ page 44).**

Setting categories

Set categories to make it easier to see what kind of programs are in the list.

- 1 Press [▶] while the program you want to categorize is highlighted.
- 2 Press [▲, ▼, ◀, ▶] to select a category and press [MENU] to confirm and return to the previous screen.

Category	Indication	Icon
Movie	MOVIE	
Music	MUSIC	
Drama	DRAMA	
Education	EDUCA	
Documentary	DOCUM	
Sports	SPORT	
Children	CHILD	
News	NEWS	
Others	OTHER	ETC

To return to the Jet Navigator list

Press [MENU].

Note

- If you have already stored 14 programs on a tape and you then store another one, the new item is added and the oldest is deleted.
- "REMAINING PROGRAM 0 DELETE JET NAVIGATOR DATA" appears when you try to store more than fifty programs. The new item is added and the oldest item is deleted.
- "REMAINING CASSETTE 0 FOR JET NAVIGATOR DATA" appears when you try to store items for more than 20 tapes. Delete all the Jet Navigator data in the VCR if you want to save the data for the tape (⇒ page 44).
- The list does not appear when playing tapes recorded on other equipment.
- Parts of the list data are recorded on the tape. Take care when recording over older recordings that you do not overlap it. It is recorded within a few minutes either side of the beginning of the recording (longer if you used EP or VP).

To demonstrate the Jet navigator function

Keep [NAVI] pressed for more than 5 seconds without inserting a cassette tape.

Finding programs—VHS Index Search System (VISS)

Use the index marks on a tape to find sections to play. The unit adds index marks when recording starts. To add them manually during recording, press [● REC] while pressing [VCR].

While stopped or during play

Press [◀◀] (backward) or [▶▶] (forward) to skip to the part you want to play.

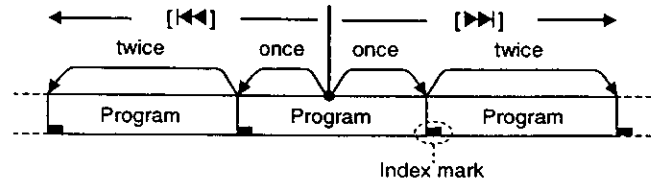

The channel, date, and time of a recording appear on the television when play restarts.

- Up to 20 index signals can be searched for in both directions.
- You can reduce the number of skips by pressing the opposite button.
- This feature may not work correctly if the marks are too close together. Make recordings of at least 15 minutes (25 minutes in VP mode).



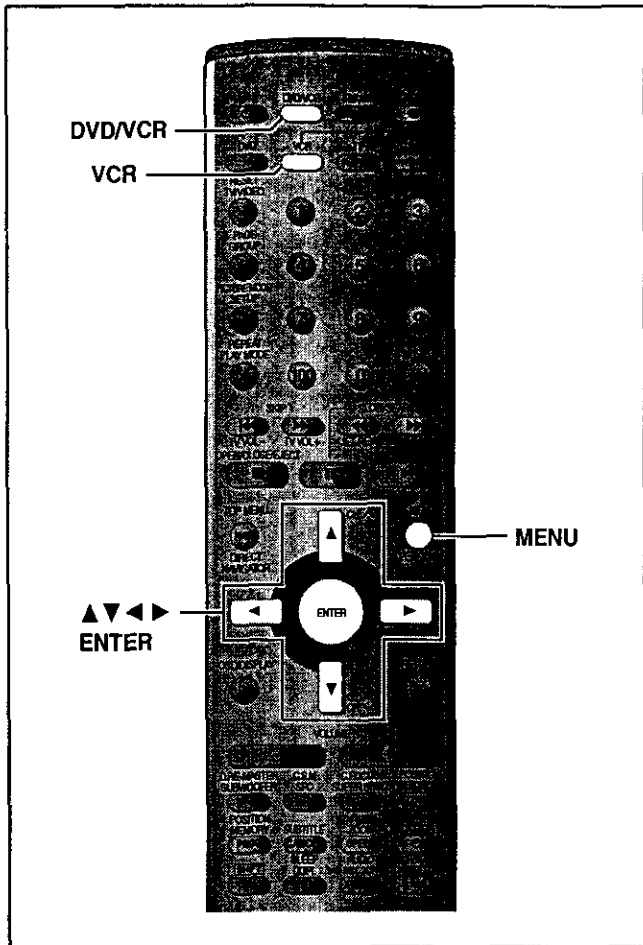

Change the settings to suit your preferences and to suit the unit to the environment in which it is being used. These settings are retained in memory until they are changed, even if the unit is turned off.

Preparation

- Press [VCR] to put the remote control in VCR mode.
- Press [DVD/VCR] to select "VCR" as the source.

Before changing the settings Press [MENU] to show the VCR MENU.

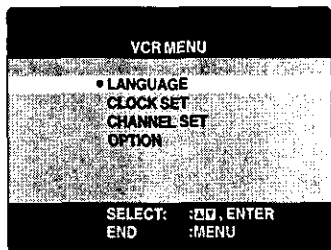

LANGUAGE

Select the language for these menus and other on screen displays.

While the VCR MENU is displayed

- 1 Press [▲, ▼] to select "LANGUAGE" and press [ENTER].
- 2 Press [▲, ▼] to choose the preferred language.

- ENGLISH (Factory preset)
- ESPAÑOL
- FRANÇAIS

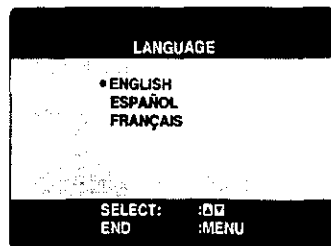

Press [MENU] to confirm and return to the previous screen.

CLOCK SET

The clock is set automatically after Plug-in Auto Tuning (→ page 15). Do the following if you want to set it again or if the time is not set correctly.

While the VCR MENU is displayed

- 1 Press [▲, ▼] to select "CLOCK SET" and press [ENTER].

AUTO CLOCK SET

- 2 Press [▲, ▼] to select "AUTO CLOCK SET" and press [ENTER].

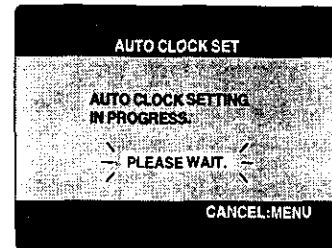

Auto setting starts. This can take some time.

To stop partway through Press [MENU].

- If the unit couldn't set the clock automatically The MANUAL CLOCK SET screen appears. Set the time manually (→ below).

MANUAL CLOCK SET

- 2 Press [▲, ▼] to select "MANUAL CLOCK SET" and press [ENTER].

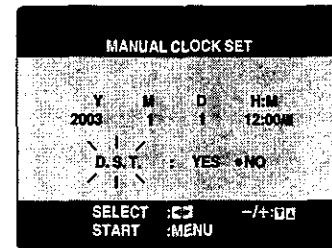

- 3 Press [◀, ▶] to select the item you want to change and press [▲, ▼] to change the setting.
- 4 Press [MENU] to start the clock and exit the setting screen.

■ Time reset function

To return the clock to the exact hour, wait until the clock in the MANUAL CLOCK SET screen is within 2 minutes either side of the hour (e.g., between 11:58:00 and 12:01:59) press [MENU] to clear the screen. The clock changes to the exact hour.

CHANNEL SET

The unit tunes automatically after you plug it in and turn it on for the first time (⇒ page 15, Plug-in Auto Tuning), but you can start the process again if necessary.

- Make sure you have tuned to a television channel. This does not work if you have selected "AU" channel.

While the VCR MENU is displayed

- 1 Press [▲, ▼] to select "CHANNEL SET" and press [ENTER].

ANTENNA SYSTEM

- 2 Press [▲, ▼] to select "ANTENNA SYSTEM" and press [ENTER].
- 3 Press [▲, ▼] to select "TV" or "CATV" to suit the type of antenna you are using.

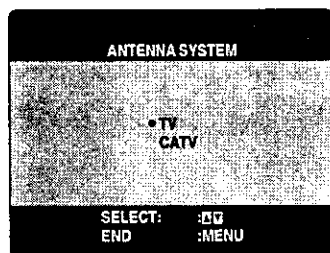

Channels are set corresponding to the antenna system you select. This is set automatically when you do Plug-in Auto Tuning.

To exit the settings screen

Press [MENU] until the screen disappears.

AUTO

Auto tuning searches for TV stations and memorizes every tuned program position. Other program positions are skipped. (Channel range ⇒ right)

- 2 Press [▲, ▼] to select "AUTO" and press [ENTER].

Auto tuning starts. It takes three or more minutes to complete.

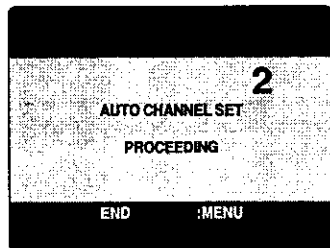

To stop partway through

Press [MENU].

MANUAL

You can manually preset channels that are skipped when using the auto channel setting, and manually skip channels that are preset.

- 2 Press [▲, ▼] to select "MANUAL" and press [ENTER].
- 3 Press [▲, ▼] to select "CH" and [◀, ▶] to select the channel.
- 4 Press [▲, ▼] to select "BLANK" and [◀, ▶] to select "ON" or "OFF".

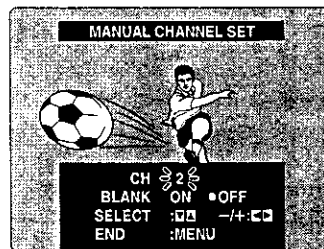

To exit the settings screen

Press [MENU] until the screen disappears.

Channel range

•TV mode

Band	Airwaves
VHF	2-13
UHF	14-69

•CATV mode

Band	Cable
VHF	2-13
CATV LOW BAND	95-99
CATV MID/SUPER BAND	14-36
CATV HYPER BAND	37-65
ULTRA BAND	66-94
	100-125
SPECIAL CATV CHANNEL	1



VCR

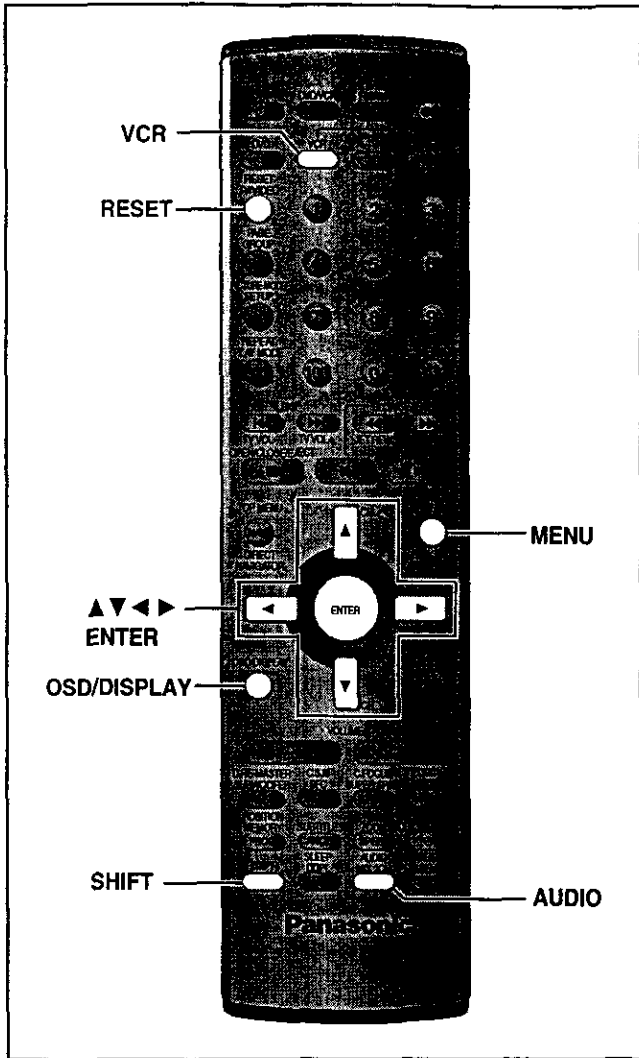

OPTION

While the VCR MENU is displayed

- 1 Press [**▲**, **▼**] to select the "OPTION" and press [ENTER].
- 2 Press [**▲**, **▼**] to select the item and press [**◀**, **▶**] to change the setting.

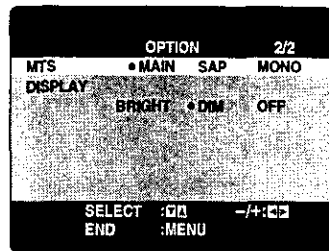
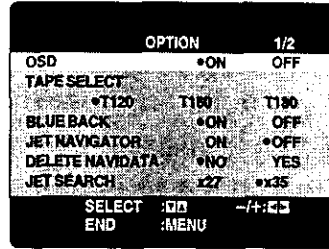

To exit the settings screen
Press [MENU] until the screen disappears.



Items	Settings (Underlined items are the factory preset.)
OSD (⇒ page 45, On-screen display)	<u>ON</u> : Messages appear on the television for about five seconds after you perform operations. OFF: Messages do not appear.
TAPE SELECT Set the length of tape you are using so the unit can show the correct remaining time.	<u>T120</u> : T30, T60, T90, T120 tapes T160: T140, T160 tapes T180: T180 tapes
BLUE BACK	<u>ON</u> : The screen shows a blue background when you play unrecorded portions. OFF
JET NAVIGATOR (⇒ page 40)	<u>ON</u> : Jet Navigator data automatically registered. <u>OFF</u> : Data not registered.
DELETE NAVIDATA Delete all the Navigation data registered in the unit. See page 40 to delete data on a single tape.	<u>NO</u> YES: Then press [ENTER] when you want to delete all the Jet navigator data.
JET SEARCH (⇒ page 34) Set the speed for JET SEARCH when playing EP and VP tapes.	×27 ×35 Select ×27 if the picture is poor at ×35.
MTS (⇒ page 45, Changing audio) Set the MTS (Multi-channel Television Sound Stereo) reception type.	<u>MAIN</u> : To receive stereo broadcasts. SAP: To receive SAP when being broadcast. MONO: To receive monaural broadcasts (e.g., when reception is poor).
DISPLAY Set the brightness of the unit's display when the unit is in standby mode.	<u>BRIGHT</u> : The display is bright all the time. <u>DIM</u> : The display dims when the unit is in standby mode. OFF: The display turns off when the unit is in standby mode.

On-screen display

To see these displays, set the OSD item in the OPTION menu to ON.

Press [OSD/DISPLAY].

The time and operation details appear on the screen for about 5 seconds.

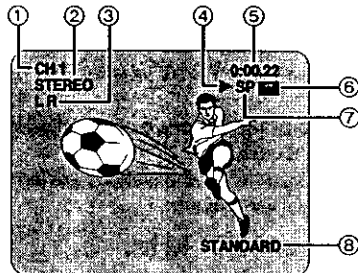

①	Channel display Displays the cable television channel or television channel currently being received.
②	STEREO/SAP indication Indicates when a program is broadcast in stereo or SAP. → right for audio type details.
③	L and R indicators The Left (L) and Right (R) indicators show which sound mode is selected as follows: Stereo: Both the L and R indicators appear. L: The L indicator appears. R: The R indicator appears. Normal: Neither the L and R indicator appears.
④	Tape running display Shows operations taking place.
⑤	Shows the time and tape counter Press [OSD/DISPLAY]. The display changes as follows. Present time → Tape counter → Remaining tape time Using index search: "S 01" to "S 20" is displayed. Using jet rewind: "J:REW" is displayed. • Press [SHIFT]+[RESET] to reset the tape counter (elapsed time) to "0:00.00". • The remaining time is approximate. It will be incorrect if you set the wrong tape time in the TAPE SELECT item in the OPTION menu and if the tape is of poor quality.
⑥	Cassette in indicator Shows whether you have loaded a cassette.
⑦	Tape speed indicator (→ page 36)
⑧	Picture mode indicator (→ page 35)

Note

- These displays do not appear when paused or during slow play.
- The on screen display may be disturbed depending on the playback tape or the input signal.

Changing audio

When a stereo and/or SAP broadcast is received, "STEREO" and/or "SAP" appear showing the type of broadcast.

To change the audio

Press [SHIFT]+[AUDIO].

The audio changes as follows:

- When playing a tape:
Stereo → L → R → Normal audio track
- While watching the television:
Stereo → L → R

The table below shows the TV broadcast type, "MTS" settings, and audio recording patterns.

TV broadcast	MTS setting	Audio track		
		Normal (Mono)	Hi-Fi	
			Left	Right
Mono	MAIN or SAP	Mono	Mono	Mono
Stereo	MAIN or SAP	L+R (Mixed)	Left	Right
Mono and SAP	MAIN	Mono	Mono	Mono
	SAP	Mono	Mono	SAP
Stereo and SAP	MAIN	L+R (Mixed)	Left	Right
	SAP	L+R (Mixed)	L+R (Mixed)	SAP

Be sure that "MTS" is set to "MAIN" or "SAP" to record on the Hi-Fi audio tracks.

Note

- Switch to "MONO" for viewing or recording if a stereo or SAP broadcast is impaired by poor reception.
- To resume stereophonic recording, set "MTS" to "MAIN" or "SAP".

Auto bilingual choice function

When you play back recordings of stereo or SAP broadcasts, these audio types are automatically selected. The unit may select a different type if you start play midway through the program. Press [SHIFT]+[AUDIO] to change the type if this occurs.

This function does not work if:

- The tape was recorded on a deck without this system.
- The tape is a recording from external equipment.



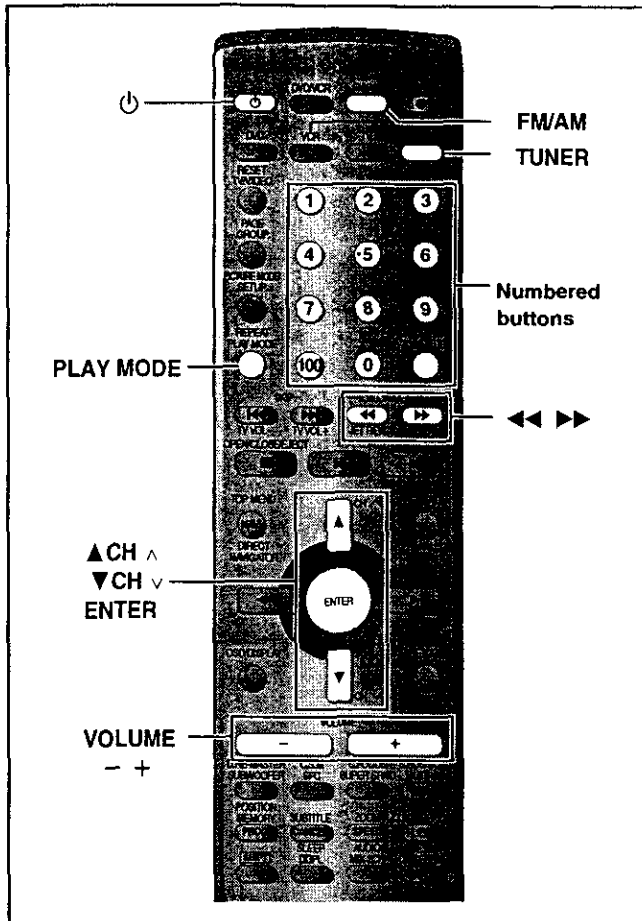

Preparation

- Press [TUNER] to put the remote control in TUNER mode.
- Press [⏻] to turn on the unit.
- Press [FM/AM] to select "FM" or "AM" as the source.

Manual tuning

- 1 Press [◀◀] or [▶▶] to select the frequency of the required station.

TUNED: Displayed when a radio station is tuned.

ST: Displayed when a stereo FM broadcast is being received.

Press and hold [◀◀] or [▶▶] until the frequency starts scrolling to start automatic tuning. Tuning stops when a station is found.

- 2 Adjust the volume.

■ If noise is excessive in FM

Press [PLAY MODE] to display "MONO". Press [PLAY MODE] again to cancel the mode. The mode is also canceled when you change the frequency.

■ FM frequency step

The step is factory-set to 0.2 MHz, but you can change it to receive broadcasts allocated 0.1-MHz steps.

- 1 Press [FM/AM] to select "AM".
- 2 Press and hold [FM/AM].

After a few seconds the display changes to show the current minimum frequency. Continue to hold the button down. The minimum frequency changes and the step is changed.

To return to the original step, repeat the above steps.

Note

Any FM and AM frequencies preset in channels will be initialized by this procedure. Preset them again.

Preset tuning

Preset channels to make selection simple. Up to 15 stations can each be set in the FM and AM bands.

Automatic presetting

- 1 Tune to "FM 87.9" MHz or "FM 87.5" MHz (⇒ left).
- 2 Press and hold [ENTER].
Release the button when "AUTO" is displayed.

The tuner presets all the stations it can receive into the channels in ascending order. "SET OK" is displayed when the stations are set. The last station to be set is then played.

- 3 Tune to "AM 520" kHz.
- 4 Press and hold [ENTER].

"ERROR" is displayed

Presetting was unsuccessful. Preset manually.

Manual presetting

- 1 Tune to the station (⇒ left).
- 2 Press [ENTER].
- 3 While "PGM" is flashing Press the numbered buttons to select a channel.

Alternatively, press [▲ CH▲] or [▼ CH▼] then press [ENTER].



The station occupying a channel is erased if another station is preset in that channel.

Selecting channels

- 1 Press [FM/AM] to select "FM" or "AM".
- 2 Press the numbered buttons or [▲ CH▲] or [▼ CH▼] to select the channel.



To select a 2-digit number

Example: To select channel 12, press [≥10] ⇒ [1] ⇒ [2]

Note

The unit of display is MHz for FM radio and kHz for AM radio when the selector is in TUNER mode.



Optional FM antenna connection

Use FM outdoor antenna if radio reception is poor.

Note

- Disconnect the outdoor antenna when the unit is not in use.
- Do not use the outdoor antenna during an electrical storm.

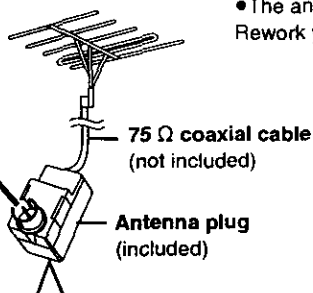
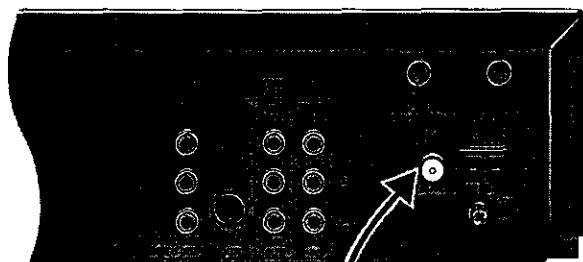

FM outdoor antenna (Using a television antenna)

- Disconnect the FM indoor antenna.
 - The antenna should be installed by a competent technician.
- Rework your outdoor antenna's 75 Ω coaxial cable as follows.

① Remove a piece of the outer vinyl insulator.

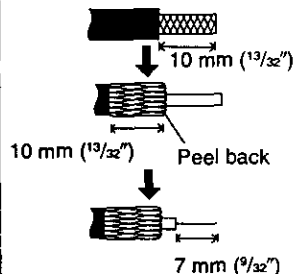

② Carefully pull the tabs apart to remove the cover.

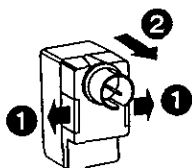

③ Install the coaxial cable.

Clamp the cable conductor, and wind it on so that it does not contact anything else.

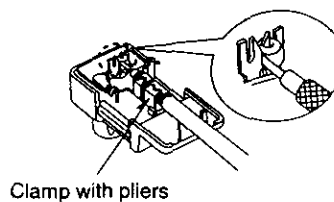

④ Attach the cover.



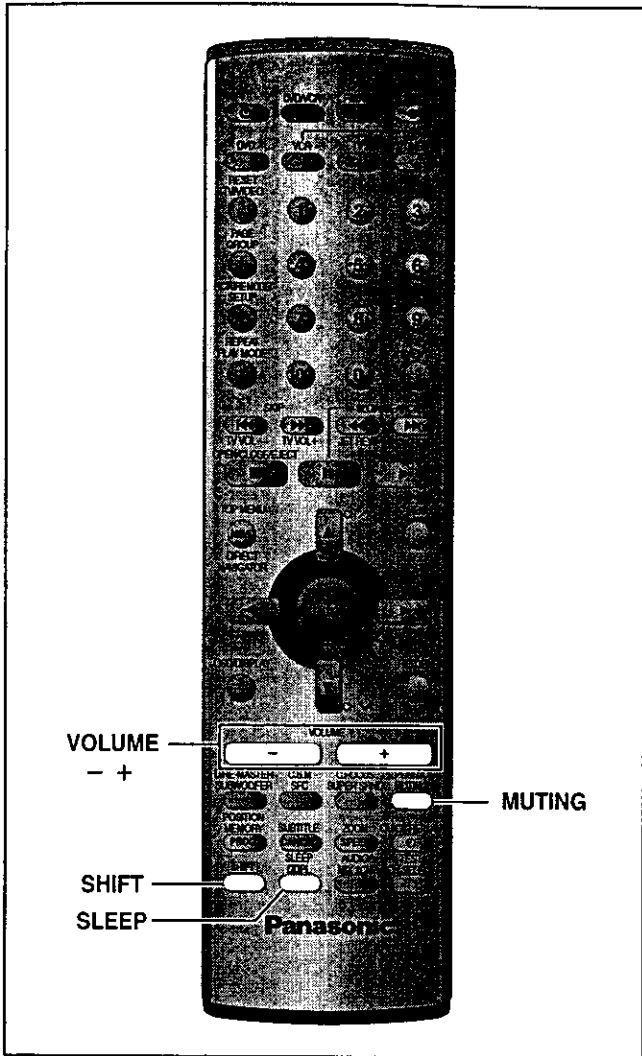

The sleep timer

Set the unit to switch to standby after a certain time.

Press [SHIFT]+[SLEEP] to select the time (minutes).



Each time you do this:

30 → 60 → 90 → 120 → OFF

To cancel the timer

Press [SHIFT]+[SLEEP] to select "OFF".

To check the SLEEP setting

Press [SHIFT]+[SLEEP] once.

• The time remaining appears.

To change the setting

Repeat the procedure from the beginning.

Note

The VCR's timer program recording functions even when the power is turned off by the sleep timer.

Muting the volume

Press [MUTING].



Volume is reduced to minimum.

To cancel

Press [MUTING] again or reduce the volume to minimum (--- dB), then raise it to the required level.

Muting is also canceled when you switch the unit to standby.

Using headphones

1 Reduce the volume and connect the headphones (not included).

Headphone plug type: 3.5 mm (1/8") stereo

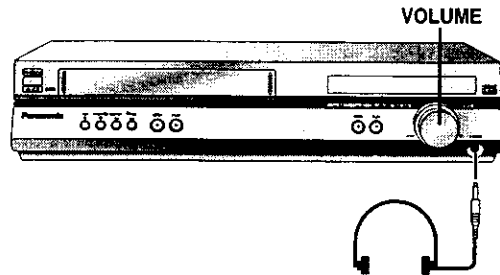



2 Adjust headphone volume with [VOLUME DOWN, UP].

Audio is automatically switched to stereo (2-channel).

Note

Avoid listening for prolonged periods of time to prevent hearing damage.

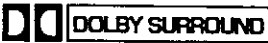

Sound field system		Features	Software	Other effects
Dolby Digital and DTS		<ul style="list-style-type: none"> •Dolby Digital and DTS are digital encoding systems used on DVD to carry surround sound. Both were originally developed for use in cinemas. •This unit automatically recognizes and decodes these systems. 	Software encoded with Dolby Digital can be identified with this mark.  Software encoded with DTS can be identified with this mark. 	Center Focus Seat position
Dolby Pro Logic		Dolby Pro Logic is a decoding system that was developed to get a better sense of presence from sources encoded with Dolby Surround. The feeling of position has been improved by the addition of a separate center speaker channel.	Software encoded with Dolby Surround can be identified with this mark (DVD, CD, Video CD, Laser Disc, Video tape). 	Center Focus Seat position
Super Surround	MUSIC	<ul style="list-style-type: none"> •This mode adds surround effects to stereo sources. •You can adjust the volume of the surround speakers to get the best surround effect. 	Any stereo sound source.	—
	MOVIE	<ul style="list-style-type: none"> •This mode adds surround effects to movie software that hasn't been recorded with the above systems. •You can adjust the volume of the surround speakers to get the best surround effect. 		Seat position
Sound Field Control		Use Sound Field Control effects to change quality and add reverberation.	Any source.	—

- You cannot use Dolby Pro Logic, Super Surround, Center Focus, or adjust subwoofer level if you have connected headphones. ("ERROR" appears on the display.)
- You may experience a reduction in sound quality when these sound field systems are used with some sources. If this occurs, turn the sound field system off.

DVD only

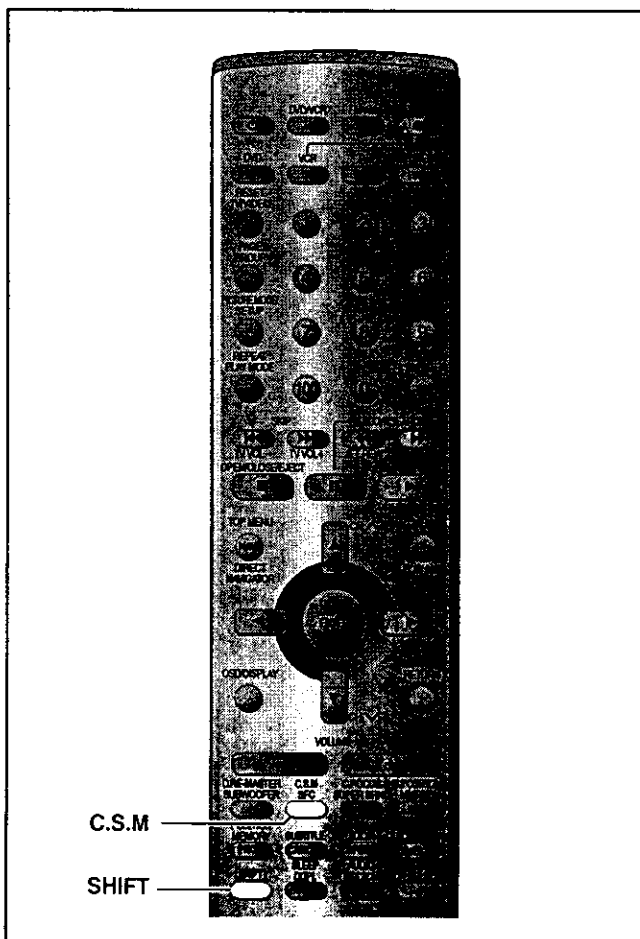

Custom Sound Memory—Store the sound settings

DVD-A **DVD-V** **VCD** **CD**

Store the sound settings indicated below for a disc so the unit recalls them the next time you play it.

- Settings: Dolby Pro Logic, Subwoofer level, Center Focus, Sound Field Control, Super Surround
- Number of discs: 30

■ Store the settings

- 1 Make the settings.
- 2 Press and hold [SHIFT]+[C.S.M].



■ Recall the settings

The unit recalls the settings when you play the disc again.

- The settings are replaced if you change them.
- When you store settings for a 31st disc, the earliest settings disappear.
- Press [SHIFT]+[C.S.M] while "CSM" is lit and the settings return to those that were on before the settings are recalled.
- Press [SHIFT]+[C.S.M] while "CSM" is out and you are playing a disc for which you stored settings and those settings are recalled.



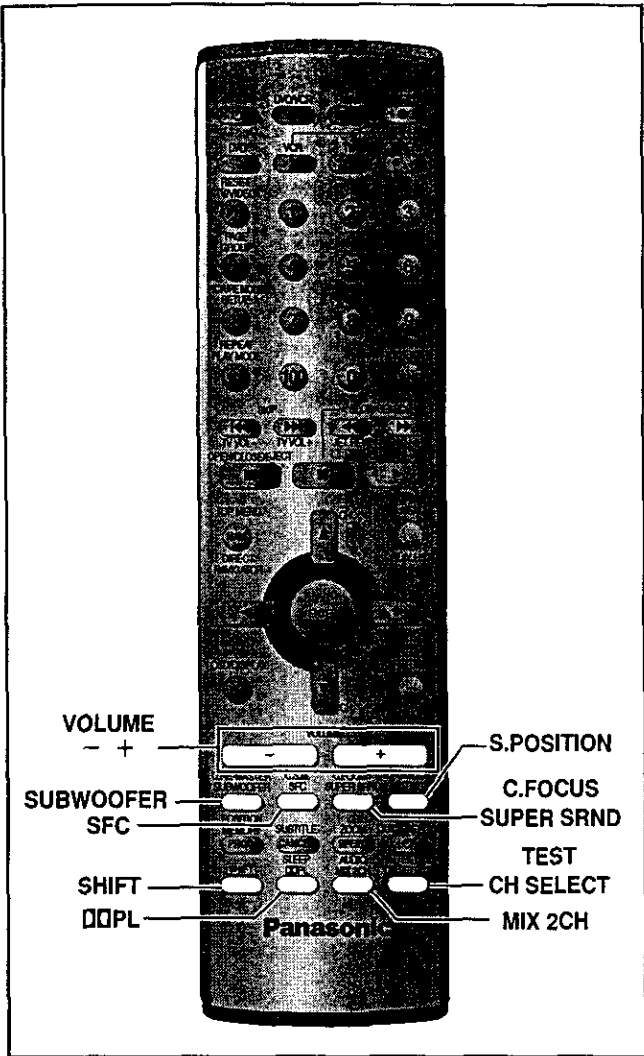

Dolby Pro Logic

- 1 Press [DOLBY PL].
- 2 Play a Dolby Surround source.



To cancel
Press [DOLBY PL] again.

Note
This does not work when playing multi-channel Dolby Digital.

Super Surround

Press [SUPER SRND].



Each time you press the button:
MUSIC → MOVIE → Off (Not displayed)

• You can adjust the volume of the surround speakers to get the best surround effect (⇒ page 51, Speaker level adjustments).

Note
• Turn Super Surround off when playing a DVD recorded with Dolby Digital or DTS. The surround effects will not be reproduced correctly if this is left on.
• Dolby Pro Logic (⇒ above) switches off.

Sound Field Control

Press [SFC] to select a setting.



- Each time you press the button:
- FLAT:** Canceled (no effect is added) (factory preset).
 - HEAVY:** Adds punch to rock.
 - CLEAR:** Clarifies higher sounds.
 - SOFT:** For background music.
 - DISCO:** Reverberates sound to make you feel like you were in a disco.
 - LIVE:** Makes vocals more alive.
 - HALL:** Expands sound to make you feel like you were in a hall.

To check the current setting
Press [SFC].

Dolby Digital and DTS

Play a Dolby Digital or DTS source.

The Dolby Digital or DTS indicator lights.



■ To down-mix Dolby Digital or DTS (multiple-channel) signals to 2 channels

Press [MIX 2CH].



To cancel, press [MIX 2CH] again.

When "D.MIX" flashes on the display **DVD-A**
The DVD-Audio contains multiple-channel signals that cannot be down-mixed.



Center Focus

You can make the sound of the center speaker seem like it is coming from within the television.

Press **[SHIFT]+[C.FOCUS]**.

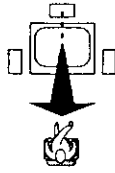

Each time you do this:

CENTER FOCUS1 (Normal) → CENTER FOCUS2 (Enhanced)
↑ OFF ↓

- This does not work when Super Surround is turned on.
- This will have less effect when Dolby Pro Logic is turned on.

Seat position

Using this function makes you feel like you are sitting in the ideal seating position (in the center of the circle formed by the speakers), even if you cannot due to the layout of your room.

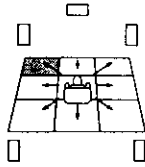

1 Press **[SHIFT]+[S.POSITION]**.



2 Press **[SHIFT]+[S.POSITION]** repeatedly to select a position.



To cancel

Press **[SHIFT]+[S.POSITION]** repeatedly to clear "S.POS".

Adjusting the bass

Press **[SUBWOOFER]**.



Each time you press the button:

SUBW 1 → SUBW 2 → SUBW 3 → SUBW 4 (factory preset)
↑

Speaker level adjustments

If the level of the speakers appears to be different while listening to a source, adjust the level of the speakers to the same apparent level.

Preparation

- Dolby Digital and DTS: Turn off the other sound field systems.
- Dolby Pro Logic: Press **[DOL]**.
- Press **[VOLUME +]** or **[-]** to set the volume level normally used for enjoying the source.

1 Press **[SHIFT]+[TEST]** to output a test signal.

Lch: Front left
Cch: Center
Rch: Front right
RSch: Right surround
LSch: Left surround

2 Press **[VOLUME +]** or **[-]**.

L, R: -16 dB to 0 dB
C, RS, LS: -10 dB to +6 dB

To stop the test signal, press **[SHIFT]+[TEST]** again.

■ To adjust speaker level during play

1 Press **[CH SELECT]** to select the speaker.

L → C → R → RS → LS → SW

SW: Subwoofer

You can only adjust SW if there is output from the subwoofer channel.

2 Press **[VOLUME +]** or **[-]**.

L, R: -16 dB to 0 dB
C, RS, LS: -10 dB to +6 dB
SW: -10 dB to +10 dB

• Super Surround

Press **[SUPER SRND]** then adjust the surround speaker level.

S: -10 dB to +6 dB



Attaching to a wall

Note

The wall or pillar on which the speakers are to be attached should be capable of supporting 10 kg (22 lb.) per screw.

1 Remove the stand. (SC-HT810V only)

BEFORE REMOVING THE STAND

- Take the speaker cable out of the stand's hole if it is threaded through.
- Lay the speaker on a soft cloth.

Unscrew the screw with a Phillips-head screwdriver.

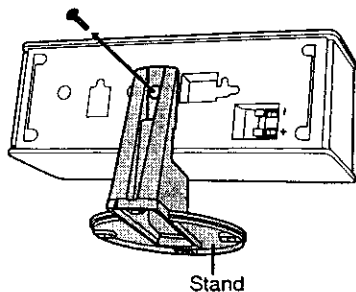

2 Screw a screw (not included) into the wall.

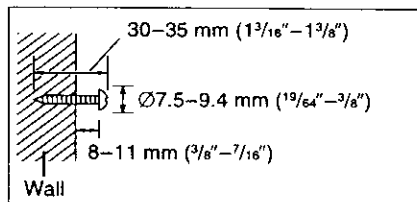

3 Fit the speaker securely onto the screw with the hole or holes.

Vertical

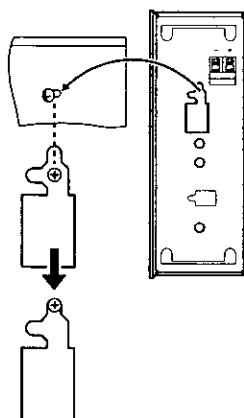

Horizontal

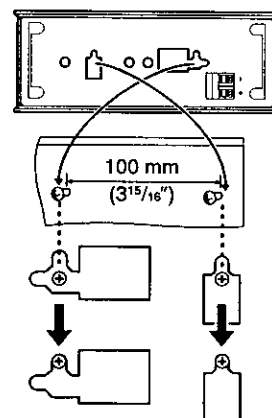

Fitting speaker stands (optional)

Preparation

- Remove the stand (SC-HT810V only → step 1 above).
- Ensure the stands meet these conditions before purchasing them.
 - Observe the diameter and length of the screws and the distance between screws as shown in the diagram.
 - The stands must be able to support over 10 kg (22 lb.).
 - The stands must be stable even if the speakers are in a high position.

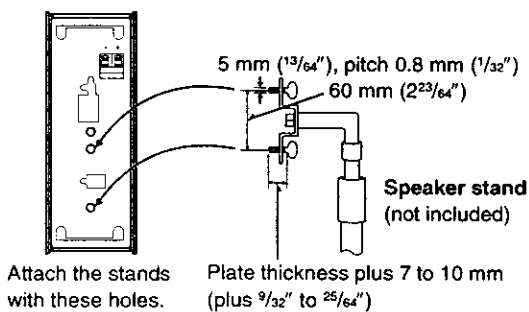

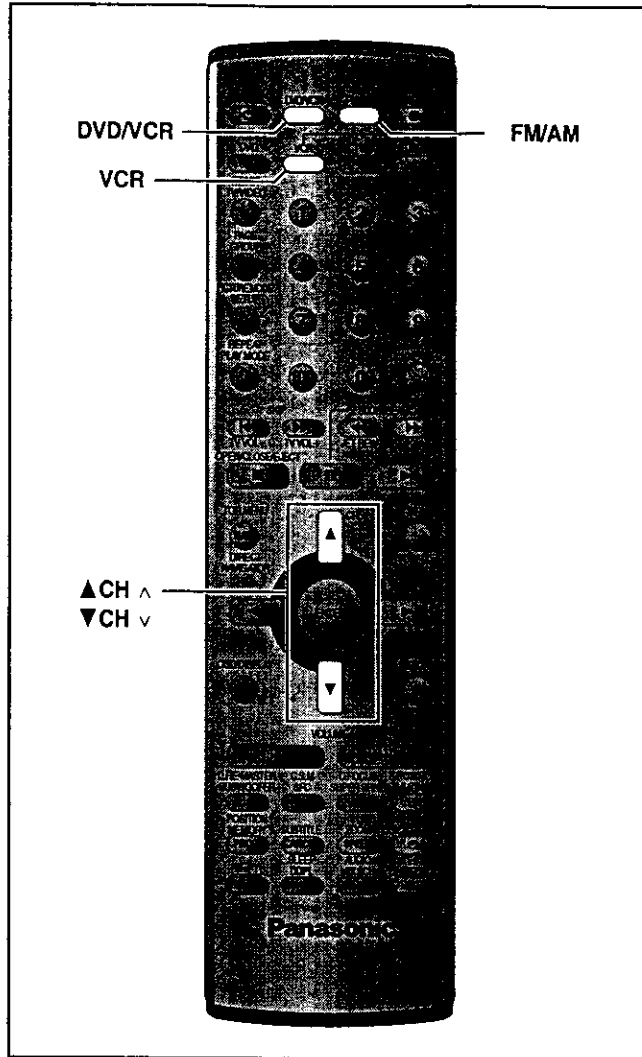

**Listening to an external source/
Recording to other equipment**

Audio cable

White (L)
Red (R)

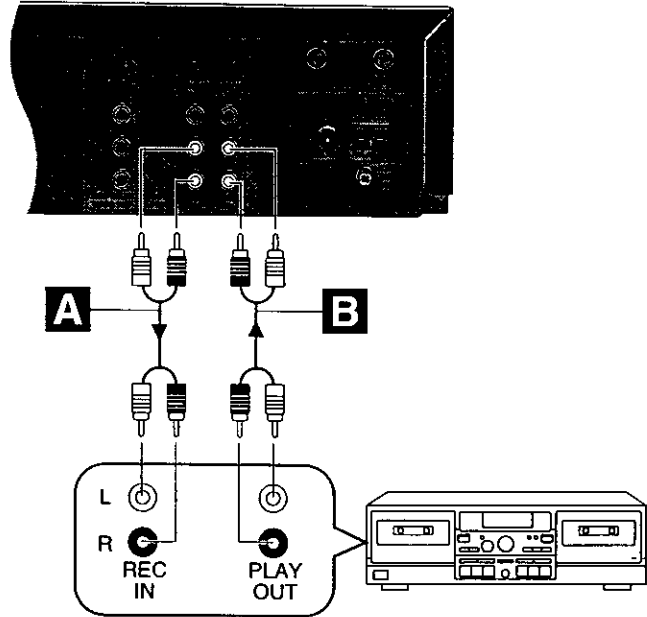
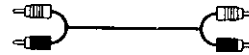

A You can record sound from discs, video cassette tapes, or radio, etc., to a tape deck.

1 Discs

Press [DVD/VCR] to select "DVD" as the source.

Video cassette tapes

Press [DVD/VCR] to select "VCR" as the source.

Radio

Press [FM/AM] to select "FM" or "AM".

2 Start recording and play.

Refer to the manual of the other unit for details.

B You can playback the sound from a tape deck/laser disc player, etc., through this unit's speakers.

1 Press [VCR] to put the remote control in VCR mode.

2 Press [DVD/VCR] to select "VCR" as the source.

3 Press [▲ CH ^] or [▼ CH v] to select "AU" channel.

4 Start play.

When connecting a record player

We recommend using a record player with a built-in phono equalizer. If your player doesn't have a built-in equalizer, connect it first to a separate equalizer and then connect that to this unit.



- The equipment connections described are examples.
- Peripheral equipment and optional cables sold separately unless otherwise indicated.
- Before connection, turn off all equipment and read the appropriate operating instructions.

Connecting a cable TV box/satellite receiver

Subscribe to a cable TV or satellite TV service.

- Consult your service provider regarding appropriate cable box or satellite receiver.
- Select the applicable input on your television to view the output from your cable box/satellite receiver through this unit.
- The signal from the cable TV box or satellite receiver passes through this unit to the television even when this unit is turned off.

One cable TV box/satellite receiver

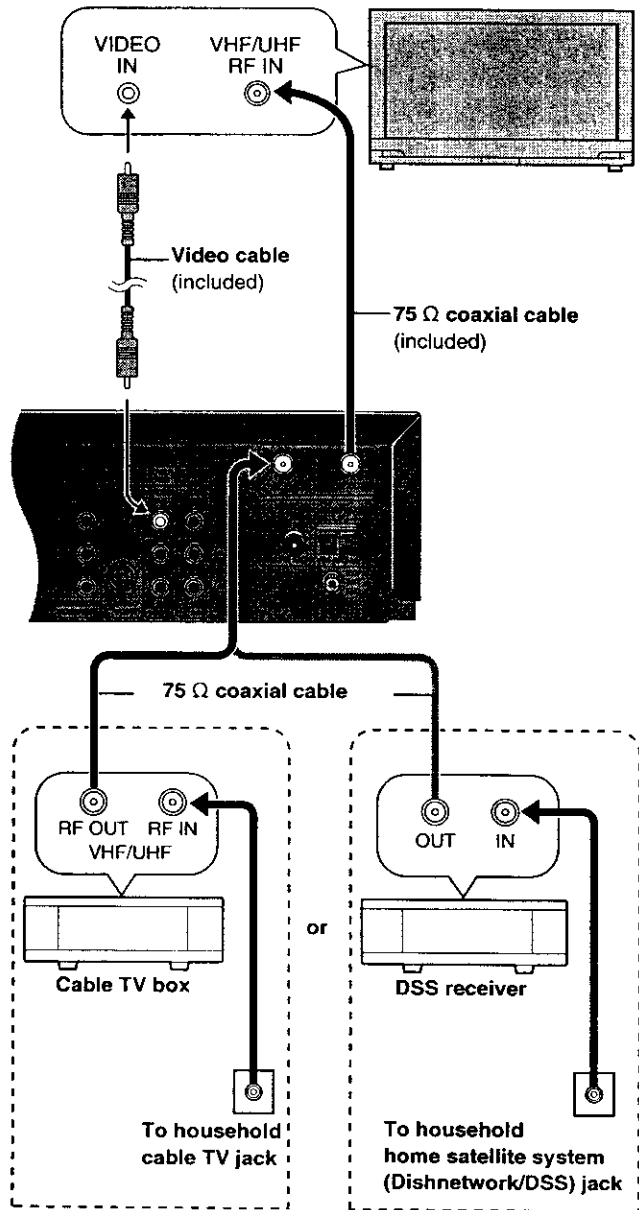

Note
When a home satellite system (Dishnetwork/DSS) is connected, auto tuning and auto clock setting may not operate properly. Set the clock manually (⇒ page 42).

- Change the video input on the television when you want to watch another program while recording.
- You cannot do a timer recording unless the channel is first selected on the cable TV box or DSS receiver.

Two cable TV boxes

- You can record and view both scrambled and unscrambled channels if connections are made as shown in the diagram below.

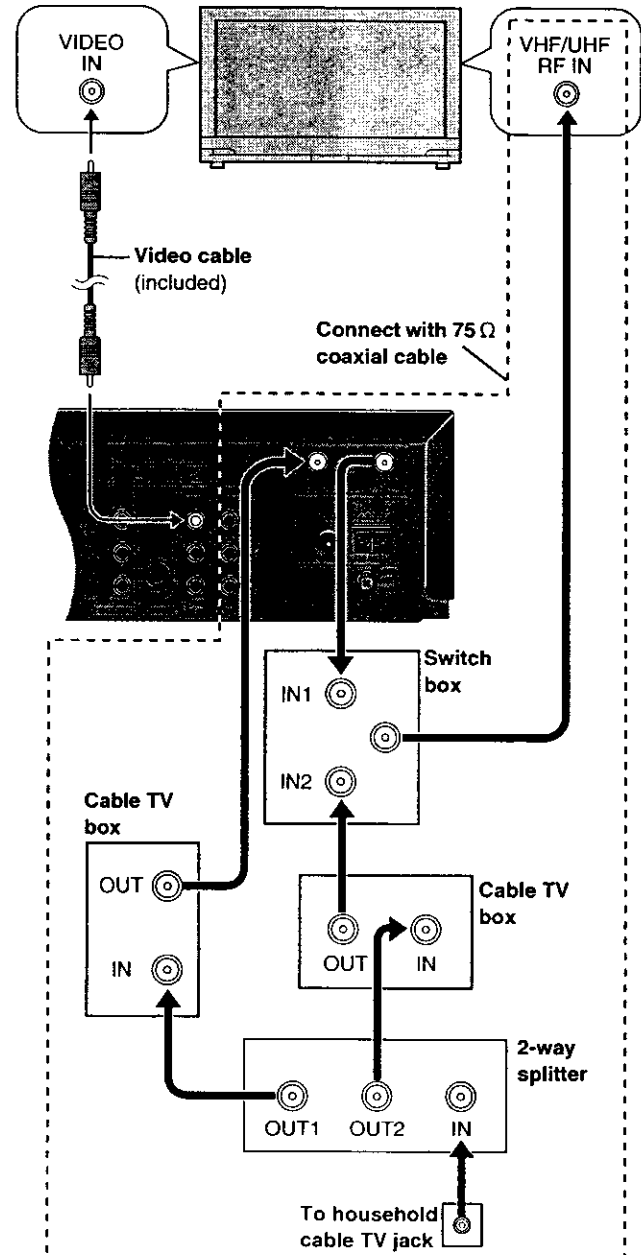

- Change the video input on the television when you want to watch another program while recording.
- You cannot do a timer recording unless the channel is first selected on the cable TV box.

Other antenna connections to the unit

Use one of the following connections to suit the antenna lead.

■ A single twin lead

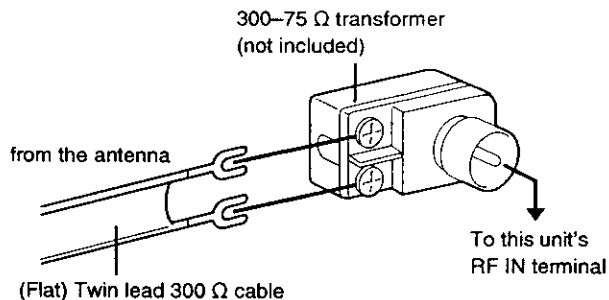

■ A twin lead and a coaxial cable

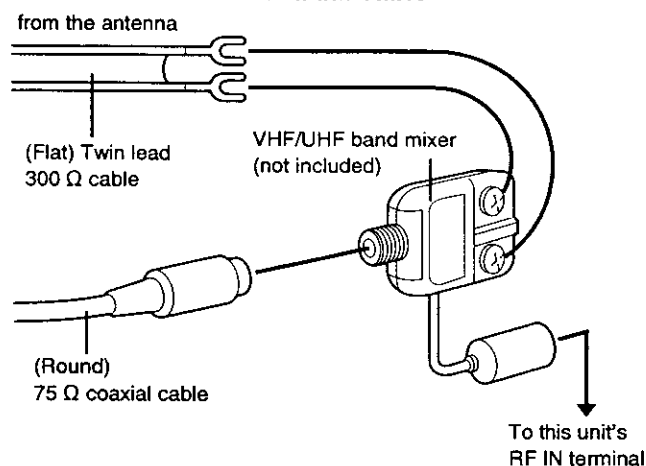

■ Two twin leads

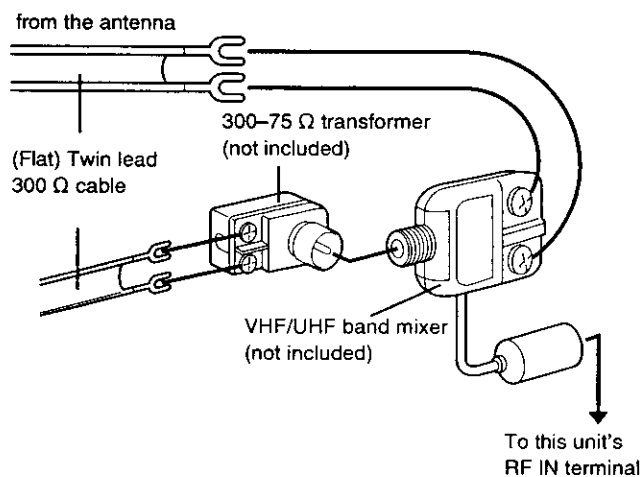

• If your television has both lead and coaxial VHF terminals, use the lead connection to minimize signal loss.

Other antenna connections from the unit to the television

Use one of the following connections to suit the antenna terminals on your television. Refer to the television's operating instructions.

■ A twin lead and coaxial plug terminal

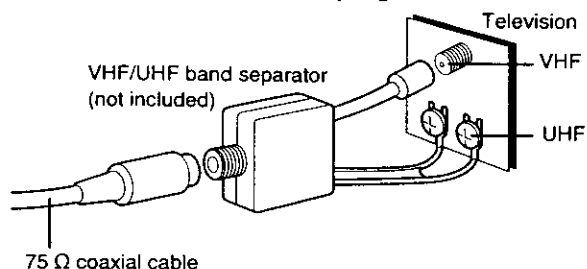

■ A twin lead terminal

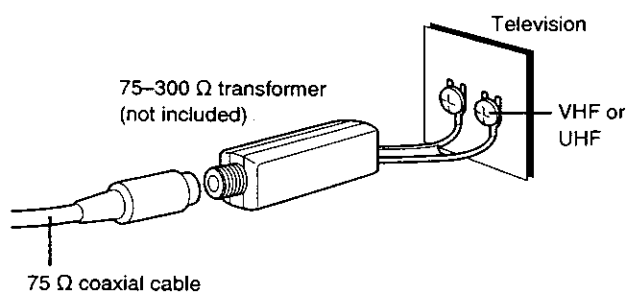

■ Two twin lead terminals

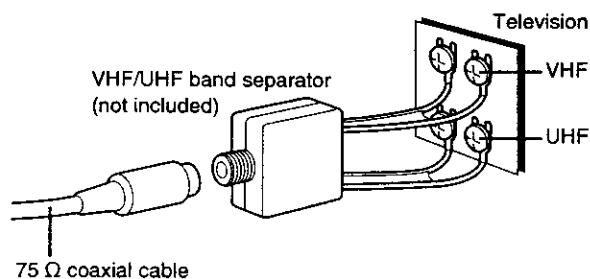

■ Multiple antenna terminals

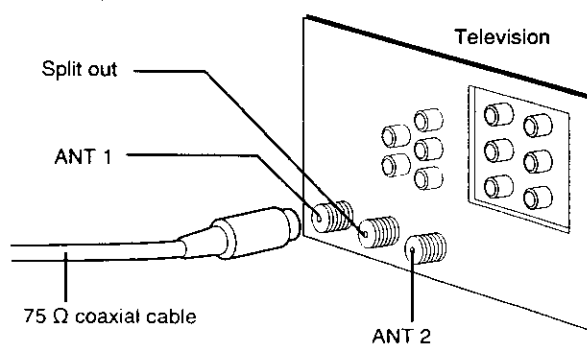

• Connect to one of the terminals, then change the television's setting as necessary.



Troubleshooting guide

Before requesting service, make the below checks. If you are in doubt about some of the check points, or if the remedies indicated in the chart do not solve the problem:

In the U.S.A., contact the Panasonic Customer Call Center at 1-800-211-7262, or e-mail consumerproducts@panasonic.com, or the website (<http://www.panasonic.com>).

In Canada, contact the Panasonic Canada Inc. Customer Care Centre at 1-800-561-5505, or visit the website (www.panasonic.ca), or an authorized Servicentre closest to you.

General

		Page
No power.	• Insert the AC power supply cords and system cable securely.	14
No response when buttons pressed.	• Some operations may be prohibited by the disc. • The unit may not be operating properly due to lightning, static electricity or some other external factor. Reset procedure: Press [⏻] to switch the unit to the standby mode and then back to ON. Alternatively, press [⏻] to switch the unit to the standby mode, disconnect both AC power supply cords, and then reconnect.	— —
Cannot select alternative languages.	• Check that the batteries are installed correctly. • The batteries are depleted: Replace them with new ones. • Point the remote control at the remote control sensor and operate.	2 2 —
The SETUP menu cannot be accessed.	• This function depends on software availability. • Try selecting from the disc's menu if one is available.	— 19
Cannot operate the VCR.	• Select "DVD" as the source. • Cancel all group, program and random play.	— 25
Cannot operate the TV.	• Press [VCR] to switch the remote control mode to VCR. • The unit is in timer recording standby ("Ⓞ" is on on the unit's display).	— 38
Cannot operate the DVD.	• Press [TV] to switch the remote control mode to TV. • Check the TV maker setting.	— 16
Television reception worsens after connecting the unit.	• Press [DVD] to switch the remote control mode to DVD.	—
Cannot eject cassette.	• This can occur because the signals are being divided between the unit and the television. You can solve this with a signal booster, available from audio-visual suppliers. Consult your dealer if reception does not improve.	—
	• The VCR is in timer recording standby or actually recording. If you need to eject the tape, press [Ⓞ] first so "Ⓞ" goes out.	38

Disc play

Play doesn't start (or stops immediately) when you press [▶] (play).	• Condensation has formed: Wait 1 to 2 hours for it to evaporate. • This unit cannot play discs other than the ones listed in these operating instructions. • This unit cannot play DVD-Video with a region number other than "1", "ALL" or multiple region numbers including "1". • The disc may be dirty and may require cleaning. • Ensure that the disc is installed with the label of the side to be played facing upwards. • Check that the DVD-RAM has something recorded on it.	— 6 Cover 6 18 —
No menu play.	• This function depends on software availability.	—
No subtitles.	• This function depends on software availability. • Subtitles are cleared from the television. Display the subtitles. • Subtitle position is wrong. Adjust the position.	— 26 26
The position of the subtitles is incorrect.	• Change the position of the subtitles with "Subtitle Position" in the on-screen icon menus.	26
Soundtrack and/or subtitle language is not the one selected with the SETUP menus.	• This function depends on software availability.	—
Cannot change angle.	• This function depends on software availability. Even if a disc has a number of angles recorded, these angles may be recorded for specific scenes only.	—
Cannot add markers.	• You cannot add markers while playing a play list or if the disc's play time doesn't appear on the unit's display.	—
There are already markers. RAM	• The unit reads and displays the markers added with a DVD video recorder. You can clear them but reappear when you switch the unit to standby, change the source, or open the disc tray.	—
Marker numbers I added are different when I call them up. RAM	• The unit numbers markers by time so they change when you add and delete them.	—
Cannot select random or program play.	• You cannot select random or program play with some DVD-Video.	—
Folders deeper than the eighth layer on a data CD are not displayed correctly.	• Folders deeper than the eighth layer are displayed as the eighth layer.	—
You have forgotten your ratings password. Reset all the SETUP settings to Factory Preset.	• While stopped and "DVD" is the source, press and hold [◀◀ (REW)], [▶▶ (PLAY)] (DVD) and [▲ DVD OPEN/CLOSE] on the main unit for about 3 seconds until "Initialized" disappears from the television. Turn the unit off and on again. All settings will return to the default values.	—
The unit doesn't play the data type (WMA/MP3 or JPEG) selected in "Mixed Disc—Audio & Stills" in the SETUP menu.	• Reload the disc for the setting to be effective. Press [SHIFT]+[OPEN/CLOSE/EJECT] to open the tray, then press [▶▶] (PLAY) to start play.	—



Sound

No sound. Distorted sound.	<ul style="list-style-type: none"> • Check the connections. • Turn the volume up. • Turn muting off. • Switch off the unit, determine and correct the cause, then switch the unit on. <p>Causes include:</p> <ul style="list-style-type: none"> – Shorting (bare wires touching) of positive and negative speaker wires. – Using speakers with an impedance lower than that rated for this unit. – Straining of the speakers through excessive volume or power. – Using the unit in a hot environment without proper ventilation. 	11, 14 — 48 —
Humming heard during play.	<ul style="list-style-type: none"> • An AC power supply cord or fluorescent light is near the subwoofer. Keep other appliances and cords away from the subwoofer. 	—
There is noise when playing a video tape.	<ul style="list-style-type: none"> • Adjust the tracking. • The tape is old or damaged. 	35 —

Picture

No picture.	<ul style="list-style-type: none"> • Check the connection. • Make sure the television is on. • Ensure the television's video input setting (e.g., VIDEO 1) is correct. 	12, 13 — —
The picture shown on the television is not normal. (The sides of the picture are cut off, the picture is stretched horizontally, or black bands appear at the top and bottom of the screen.)	<ul style="list-style-type: none"> • Go to Video in the SETUP menus, and change "TV Aspect" to suit your television. • Use the television to change the aspect to the correct one. <p>If your television cannot change the aspect when input is progressive, try changing 4:3 Aspect with the on-screen menu icons.</p> <ul style="list-style-type: none"> • Ensure that the unit is connected directly to the television, and is not connected through an AV selector or other equipment. • Connect to the component video input terminals on a 480P compatible television. (Video will not be displayed correctly if connected to an incompatible television.) • Change the size with the variable zoom function. • The images on PAL system DVD-Audio are compressed for display. They may also appear vertically stretched. 	31 30 — 13 27 —
The picture on the television disappears or stripes appear on the screen.	<ul style="list-style-type: none"> • Mobile telephone chargers can cause some disturbance. • The location and orientation of the antenna are incorrect. If you are using an indoor antenna, change to an outdoor antenna. • The television antenna wire is too close to the unit. Separate the antenna wire of the television from the unit. 	— 47 —

Disc picture

Picture distorted.	<ul style="list-style-type: none"> • Some distortion is normal during SEARCH. 	—
There is ghosting when progressive output is on.	<ul style="list-style-type: none"> • Press [PROGRESSIVE] to turn off progressive output. This problem is caused by the editing method or material used on DVD-Video, but should be corrected if you use interlace output. 	18
Picture quality is poor.	<ul style="list-style-type: none"> • Check the settings in the On-Screen Menu Icons' Picture Menu. 	30
Menus not displayed correctly.	<ul style="list-style-type: none"> • Change the zoom ratio to "×1.00". • With the on-screen icon menus, change "Subtitle Position" to "0" or change "4:3 Aspect" to "Normal". 	27 26, 30

VCR picture

The picture is noisy or is in black and white.	<ul style="list-style-type: none"> • Adjust the tracking. • Make sure the television's input setting is correct. 	35 —
Horizontal bars or lines run down the screen.	<ul style="list-style-type: none"> • The video heads are dirty: clean them with a head-cleaning cassette. • The video heads are worn: consult your dealer. • The tape is old or damaged. • You cannot correctly play tapes recorded with other systems (e.g., PAL). 	59 — —
Picture is distorted when stilled or during slow-motion.	<ul style="list-style-type: none"> • Some distortion is normal with tapes recorded using VP mode. 	—
The blue back appears during play.	<ul style="list-style-type: none"> • You are playing a blank or poor quality part of the tape. • You can damage the unit if you play dirty or damaged tapes and this can cause the blue back to appear. Consult your dealer. 	— —
The picture jiggles.	<ul style="list-style-type: none"> • Adjust the vertical hold. 	35



Recording

<p> flashes when I try to start recording. Cannot record.</p>	<ul style="list-style-type: none"> • If the erasure prevention tab has been removed, cover the hole with adhesive tape. 	5
<p>Timer recording doesn't record a program correctly.</p>	<ul style="list-style-type: none"> • Check the clock and calendar. • Set the channel and start and end times correctly. • Be sure to press [⏻] after programming to put the unit in timer recording standby. • Program times may be overlapped. 	38
<p>Cannot record from other equipment.</p>	<ul style="list-style-type: none"> • Press [▲ CH▲] or [▼ CH▼] to Select "AU". • Check the connections to the other equipment. 	37
<p>Black bands appear in the recording.</p>	<ul style="list-style-type: none"> • Move the other equipment away from the television as it may be picking up interference. 	—
<p>The copy of a videotape or DVD is very poor.</p>	<ul style="list-style-type: none"> • This unit complies with industry standards regarding the recording and duplication of copy-protected material. This includes commercial videotapes and DVDs. Consequently, copying not only infringes copyright laws but also presents serious technical difficulties. Even in cases where a copy can be made, the quality will be very poor. 	—

Listening to the radio

<p>Cannot select the tuner</p>	<ul style="list-style-type: none"> • Check and see if the subwoofer's AC power supply cord is connected. 	14
<p>Noise is heard. "ST" flickers or doesn't light. Sound is distorted.</p>	<ul style="list-style-type: none"> • Adjust the position of the FM or AM antenna. • Use an outdoor antenna. 	47
<p>A beat sound is heard.</p>	<ul style="list-style-type: none"> • Turn the television off or separate it from the unit. 	—
<p>A low hum is heard during AM broadcasts.</p>	<ul style="list-style-type: none"> • Separate the antenna from other cables and cords. 	—

Unit display

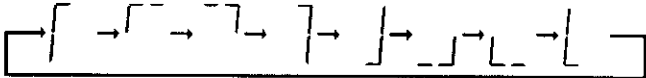
<p>The unit's display disappears or fades once the power is turned off.</p>	<ul style="list-style-type: none"> • The DISPLAY setting is set to "DIM" or "OFF" under OPTION from the VCR MENU. Select "BRIGHT" if you want the display bright all the time. 	44
<p>The tape counter isn't changing.</p>	<ul style="list-style-type: none"> • The tape counter does not change while playing unrecorded parts.  <ul style="list-style-type: none"> • The display also appears like this if the tape is dirty or damaged. Consult your dealer if this is the case. 	—
<p>No PLAY</p>	<ul style="list-style-type: none"> • You inserted a disc the unit cannot play; insert one it can. • You inserted a blank DVD-RAM. 	6
<p>"No DISC"</p>	<ul style="list-style-type: none"> • You haven't inserted a disc; insert one. • You haven't inserted the disc correctly; insert it correctly. 	18
<p>"F61"</p>	<ul style="list-style-type: none"> • Check and correct the speaker cord connections. • If this does not fix the problem, there is a power supply problem. Consult the dealer. 	11, 14
<p>"U11"</p>	<ul style="list-style-type: none"> • Disc is dirty. Wipe it clean. 	6
<p>ERROR</p>	<ul style="list-style-type: none"> • Incorrect operation performed. Read the instructions and try again. 	—
<p>"H□□", "F□□" □□ stands for a number.</p>	<ul style="list-style-type: none"> • Trouble may have occurred. The number following "H" or "F" depends on the status of the unit. <p>Reset procedure: Press [⏻] to switch the unit to the standby mode and then back to ON. Alternatively, press [⏻] to switch the unit to the standby mode, disconnect both AC power supply cords, and then reconnect. <ul style="list-style-type: none"> • If the service numbers fail to clear, note the service number and contact a qualified service person. </p>	—

Television display

<p>Cannot display group xx, picture xx</p>	<ul style="list-style-type: none"> • You are trying to display incompatible pictures. 	—
<p>No on-screen display.</p>	<ul style="list-style-type: none"> • Go to Display in the SETUP menus, and select "On" for "On-Screen Messages". • Go to OPTION in the VCR MENU, and select "ON" for "OSD". 	31
<p>On-Screen Menu Icons not displayed or only partially displayed on the television.</p>	<ul style="list-style-type: none"> • Press [▲, ▼] while the rightmost icon is highlighted to move them down. 	44 28
<p>The menu is displayed in a different language.</p>	<ul style="list-style-type: none"> • Go to Disc in the SETUP menus, and select the preferred language for "Menus". • Go to LANGUAGE in the VCR MENU, and select the preferred language for menus. 	31 42



Decoder

A decoder restores the coded audio signals on DVDs to normal. This is called decoding.

Dolby Digital

This is a method of coding digital signals developed by Dolby Laboratories. Apart from stereo (2-channel) audio, these signals can also be multi-channel audio. A large amount of audio information can be recorded on one disc using this method.

Dolby Pro Logic

A surround system where a 4-channel audio track is recorded as 2 channels and then is restored to 4 channels for play. The surround channel is monaural and can reproduce up to 7 kHz.

DTS (Digital Theater Systems)

This surround system is used in many movie theaters around the world. There is good separation between the channels, so realistic sound effects are possible.

Dynamic range

Dynamic range is the difference between the lowest level of sound that can be heard above the noise of the equipment and the highest level of sound before distortion occurs.

Film and video

DVD-Videos are recorded using either film or video. Usually, film is recorded at 24 frames per second, the rate movies are filmed at, while video is recorded at 30 frames per second.

Frame still and field still

Frames are the still pictures that make moving pictures. About thirty are shown each second. A frame still may appear blurred but overall quality is high.

Two fields appear alternately to make up one frame. A field still is not blurred but picture quality is lower.

Interlace and progressive output

NTSC, the video signal standard, has 480 interlaced (I) scan lines, whereas progressive scanning uses twice the number of scan lines. This is called 480P.

I/P/B

MPEG 2, the video compression standard adopted for use with DVD-Video, codes frames using these 3 picture types.

I: Intra coded picture

This picture has the best quality and is the best to use when adjusting the picture.

P: Predictive coded picture

This picture is calculated based on past I or P-pictures.

B: Bidirectionally-predictive coded picture

This picture is calculated by comparing past and future I and P-pictures so it has the lowest volume of information.

Linear PCM (pulse code modulation)

These are uncompressed digital signals, similar to those found on CDs.

Maintenance

To clean this unit, wipe with a soft, dry cloth.

- Never use alcohol, paint thinner or benzine to clean this unit.
- Before using chemically treated cloth, read the instructions that came with the cloth carefully.

Cleaning the video heads

Dirt on the video heads can cause poor recording and play.



To clean the heads, insert and eject a tape 5 to 10 times in succession.

If the picture does not improve, use an optional head-cleaning cassette (part number NV-TCL30PT). If the problem persists, seek advice from a qualified service person.

■ AMPLIFIER SECTION

SC-HT790V

RMS output power, 10 % total harmonic distortion

1 kHz FL/FR	40 W per channel 6 Ω
1 kHz Center	50 W per channel 6 Ω
1 kHz SL/SR	40 W per channel 6 Ω
100 Hz Subwoofer	140 W per channel 4 Ω

Total RMS Dolby Digital mode power 350 W

FTC output power, 1 % total harmonic distortion

120 Hz–20 kHz FL/FR	20 W per channel 6 Ω
120 Hz–20 kHz Center	25 W per channel 6 Ω
120 Hz–20 kHz SL/SR	20 W per channel 6 Ω
45 Hz–120 Hz Subwoofer	85 W per channel 4 Ω

Total FTC power in Dolby Digital mode (Band 1 % THD) 190 W

SC-HT800V

RMS output power, 10 % total harmonic distortion

1 kHz FL/FR	45 W per channel 6 Ω
1 kHz Center	60 W per channel 6 Ω
1 kHz SL/SR	45 W per channel 6 Ω
100 Hz Subwoofer	160 W per channel 4 Ω

Total RMS Dolby Digital mode power 400 W

FTC output power, 1 % total harmonic distortion

120 Hz–20 kHz FL/FR	25 W per channel 6 Ω
120 Hz–20 kHz Center	30 W per channel 6 Ω
120 Hz–20 kHz SL/SR	25 W per channel 6 Ω
45 Hz–120 Hz Subwoofer	90 W per channel 4 Ω

Total FTC power in Dolby Digital mode (Band 1 % THD) 220 W

SC-HT810V

RMS output power, 10 % total harmonic distortion

1 kHz FL/FR	50 W per channel 6 Ω
1 kHz Center	100 W per channel 6 Ω
1 kHz SL/SR	50 W per channel 6 Ω
100 Hz Subwoofer	200 W per channel 4 Ω

Total RMS Dolby Digital mode power 500 W

FTC output power, 1 % total harmonic distortion

120 Hz–20 kHz FL/FR	27 W per channel 6 Ω
120 Hz–20 kHz Center	62 W per channel 6 Ω
120 Hz–20 kHz SL/SR	27 W per channel 6 Ω
45 Hz–120 Hz Subwoofer	130 W per channel 4 Ω

Total FTC power in Dolby Digital mode (Band 1 % THD) 300 W

Input sensitivity

AUX 250 mV

Input impedance

47 kΩ

■ SPEAKER SECTION

• Front/Surround/Center speakers

SC-HT790V | SC-HT800V

Front/Surround speakers SB-FS803 | Center speaker SB-PC803

Type 1 way, 1 speaker, Bass-ref.

Speakers

Full range 6.5 cm (2 1/2"), cone type, 6 Ω

Input power 60 W (Music)

Output sound pressure level 79 dB/W (1.0 m)

Frequency range 110 Hz–25 kHz (–16 dB)

130 Hz–22 kHz (–10 dB)

Dimensions (W×H×D)

SB-FS803 92×182×90 mm (3 5/8"×7 1/8"×3 17/32")

SB-PC803 180×96×90 mm (7 3/32"×3 25/32"×3 17/32")

Mass 0.86 kg (1.9 lb.)

SC-HT810V

Front speakers SB-FS700 | Surround speakers SB-FS801A

Center speaker SB-PC700

Type

SB-FS700 | SB-FS801A 1 way, 1 speaker, Bass-ref.

SB-PC700 1 way, 2 speaker, Bass-ref.

Speakers

Full range

SB-FS700 | SB-FS801A 6.5 cm (2 1/2"), cone type, 6 Ω

SB-PC700 6.5 cm (2 1/2"), cone type×2, 6 Ω

Input power

SB-FS700 | SB-FS801A 60 W (Music)

SB-PC700 (With filter) 220 W (Music)

Output sound pressure level

SB-FS700 | SB-FS801A 79 dB/W (1.0 m)

SB-PC700 82 dB/W (1.0 m)

Frequency range

SB-FS700 95 Hz–25 kHz (–16 dB)

110 Hz–22 kHz (–10 dB)

110 Hz–25 kHz (–16 dB)

130 Hz–22 kHz (–10 dB)

Dimensions (W×H×D) (With stand)

SB-FS700 135×295×145 mm (5 1/16"×11 5/8"×5 23/32")

SB-FS801A 110×226×133 mm (4 11/32"×8 29/32"×5 1/4")

SB-PC700 250×140×145 mm (9 27/32"×5 1/2"×5 23/32")

Mass

SB-FS700 1.1 kg (2.4 lb.)

SB-FS801A 0.93 kg (2.1 lb.)

SB-PC700 1.6 kg (3.5 lb.)

• Active subwoofer

SC-HT790V | Subwoofer SB-WA312

SC-HT800V | Subwoofer SB-WA310

SC-HT810V | Subwoofer SB-WA330

Type

1 way, 1 speaker, Bass-ref.

Speaker unit

Woofer

17 cm (6 3/4"), cone type, 4 Ω

Input power

200 W (Music)

Output sound pressure level

80 dB/W (1.0 m)

Frequency range

40 Hz–220 Hz (–16 dB)

45 Hz–180 Hz (–10 dB)

Dimensions (W×H×D)

160×450×424 mm

(6 5/16"×17 23/32"×16 11/16")

Mass

SB-WA312 | SB-WA310 10.8 kg (23.8 lb.)

SB-WA330 11.5 kg (25.4 lb.)



■ DISC SECTION

Disc played	(one layer per side)
DVD-VIDEO/AUDIO	8 cm/12 cm, single/double-sided, single/double layer
CD/VCD/MP3/WMA	8 cm/12 cm, CD-R/RW
DVD-RAM/R (DVD-VIDEO formatted discs)	
HighMAT	Level 2 (Audio and Image)
Video	
Signal system	NTSC
Output level	Composite video; 1 Vp-p (75 Ω) S-video; 1 Vp-p (Y), 0.286 Vp-p (C) (75 Ω) Component video; 1 Vp-p (Y) (75 Ω) 0.7 Vp-p (Pb/Cb, Pr/Cr) (75 Ω)
Audio	
Sampling frequency	
CD	44.1 kHz
MP3	32 kHz, 44.1 kHz, 48 kHz
DVD	48 kHz, 96 kHz (video), 192 kHz (audio)
Bitrate	
MP3	32–320 kbps
Decoding	16/20/24 bit linear
Pick up	
Beam Source	Semiconductor Laser
Wavelength	
CD/VCD	780 nm
DVD	658 nm
Number of channels	5.1 ch (FL, FR, SL, SR, C, SW)
Frequency response	20 Hz–20 kHz (+1, –2 dB)
Wow and flutter	Less than possible measurement data
Digital filter	8 fs
D/A converter	Delta sigma DAC

■ VCR SECTION

Video recording system	2 rotary heads, helical scanning system
Video heads	4 heads
Audio heads	2 heads
Tape speed	SP; 33.35 mm/s, EP; 11.12 mm/s
Tape format	VHS tape
Recording/playback time	SP; 120 min. with NV-T120 EP; 360 min. with NV-T120
FF/REW time	Approx. 54 s. with NV-T120 (FF/REW) Approx. 36 s. with NV-T120 (JET REW)

VIDEO

Television system	EIA; Standard (525 lines, 60 fields), NTSC color signal
Modulation system	Luminance; FM azimuth recording Color signal; converted subcarrier phase shift recording
Input level	VIDEO IN (PHONO); 1 Vp-p, 75 Ω
Output level	VIDEO OUT (PHONO); 1 Vp-p, 75 Ω
Antenna receive input	VHF 2–13 CH, 75 Ω UHF 14–69 CH, 75 Ω CATV 5A and A-5–EEE CH, 75 Ω

AUDIO

Input level	AUDIO IN (PHONO); –10 dBV, 47 kΩ
Output level	AUDIO OUT (PHONO); –8 dBV, 1 kΩ
Audio track	1 track (normal-mono only), 2 channels (Hi-Fi sound stereo)
Video horizontal resolution	Color; more than 200 lines
Signal-to-Noise ratio	Video; more than 40 dB/SP Audio; more than 60 dB/Hi-Fi
Audio frequency response	20 Hz–20 kHz/Hi-Fi
Wow and flutter	0.005 % Wrms/Hi-Fi

■ FM TUNER SECTION

Frequency range	87.9–107.9 MHz (200-kHz step) 87.5–108.0 MHz (100-kHz step)
Sensitivity	2.5 μV (IHF)
S/N 26 dB	2.2 μV
Antenna terminals	75 Ω (unbalanced)
Preset station	15

■ AM TUNER SECTION

Frequency range	520–1710 kHz (10-kHz step)
AM Sensitivity S/N 20 dB at 1000 kHz	560 μV/m
Preset station	15

■ GENERAL

Power supply	AC 120 V, 60 Hz
Power consumption	
Main unit	38 W
Active subwoofer	
SB-WA312	160 W
SB-WA310	210 W
SB-WA330	
Dimensions (W×H×D)	430×93×356 mm (16 ¹⁵ / ₁₆ "×3 ²¹ / ₃₂ "×14 ¹ / ₃₂ "
Mass	4.6 kg (10.1 lb.)

Power consumption in standby mode

BRIGHT mode	Approx. 3.7 W
DIM mode	Approx. 3.5 W
OFF mode	Approx. 2.4 W

Note

- Specifications are subject to change without notice. Mass and dimensions are approximate.
- Total harmonic distortion is measured by the digital spectrum analyzer.



Panasonic Consumer Electronics Company,
Division of Matsushita Electric Corporation of America
One Panasonic Way Secaucus, New Jersey 07094

Panasonic Sales Company, Division of Matsushita Electric of Puerto Rico, Inc.
Ave. 65 de Infantería, Km. 9.5
San Gabriel Industrial Park, Carolina, Puerto Rico 00985

Panasonic/Technics Audio Products Limited Warranty

Limited Warranty Coverage

If your product does not work properly because of a defect in materials or workmanship, Panasonic Consumer Electronics Company or Panasonic Sales Company (collectively referred to as "the warrantor") will, for the length of the period indicated on the chart below, which starts with the date of original purchase ("warranty period"), at its option either (a) repair your product with new or refurbished parts, or (b) replace it with a new or a refurbished product. The decision to repair or replace will be made by the warrantor.

Product or Part Name	Parts	Labor
Audio Products (except items listed below)	One (1) year	One (1) year
All Audio Racks (cabinets)	Thirty (30) days	Not Applicable
Technics Stand Alone Speakers, Subwoofer Speakers	Three (3) years	Three (3) years
USB Reader-Writer, Personal Computer Card Adapters (in exchange for defective item)	One (1) year	Not Applicable
Accessories: Headphones, Cartridges, Microphones, Adapters	Ninety (90) days	Ninety (90) days
Rechargeable Batteries (in exchange for defective item)	Ten (10) days	Not Applicable
SD Memory Cards, Rechargeable Battery Packs (in exchange for defective item)	Ninety (90) days	Not Applicable

During the "Labor" warranty period there will be no charge for labor. During the "Parts" warranty period, there will be no charge for parts. You must carry-in or mail-in your product during the warranty period. If non-rechargeable batteries are included, they are not warranted. This warranty only applies to products purchased and serviced in the United States or Puerto Rico. This warranty is extended only to the original purchaser of a new product which was not sold "as is". A purchase receipt or other proof of the original purchase date is required for warranty service.

Carry-In or Mail-In Service

For Carry-In or Mail-In Service in the United States call 1-800-211-PANA (1-800-211-7262) or visit Panasonic web site: <http://www.panasonic.com>

For assistance in Puerto Rico call Panasonic Sales Company (787)-750-4300 or fax (787)-768-2910.

Limited Warranty Limits And Exclusions

This warranty ONLY COVERS failures due to defects in materials or workmanship, and DOES NOT COVER normal wear and tear or cosmetic damage. The warranty ALSO DOES NOT COVER damages which occurred in shipment, or failures which are caused by products not supplied by the warrantor, or failures which result from accidents, misuse, abuse, neglect, mishandling, misapplication, alteration, faulty installation, set-up adjustments, misadjustment of consumer controls, improper maintenance, power line surge, lightning damage, modification, or commercial use (such as in a hotel, office, restaurant, or other business), rental use of the product, service by anyone other than a Factory Servicenter or other Authorized Servicer, or damage that is attributable to acts of God.

THERE ARE NO EXPRESS WARRANTIES EXCEPT AS LISTED UNDER "LIMITED WARRANTY COVERAGE". THE WARRANTOR IS NOT LIABLE FOR INCIDENTAL OR CONSEQUENTIAL DAMAGES RESULTING FROM THE USE OF THIS PRODUCT, OR ARISING OUT OF ANY BREACH OF THIS WARRANTY. (As examples, this excludes damages for lost time, travel to and from the servicer, loss of media or images, data or other memory content. The items listed are not exclusive, but are for illustration only.) **ALL EXPRESS AND IMPLIED WARRANTIES, INCLUDING THE WARRANTY OF MERCHANTABILITY, ARE LIMITED TO THE PERIOD OF THE LIMITED WARRANTY.**

Some states do not allow the exclusion or limitation of incidental or consequential damages, or limitations on how long an implied warranty lasts, so the exclusions may not apply to you.

This warranty gives you specific legal rights and you may also have other rights which vary from state to state. If a problem with this product develops during or after the warranty period, you may contact your dealer or Servicenter. If the problem is not handled to your satisfaction, then write to the warrantor's Consumer Affairs Department at the addresses listed for the warrantor.

PARTS AND SERVICE WHICH ARE NOT COVERED BY THIS LIMITED WARRANTY ARE YOUR RESPONSIBILITY.

Customer Services Directory

For Product Information, Operating Assistance, Literature Request, Dealer Locations, and all Customer Service inquiries please contact:
1-800-211-PANA (7262), Monday-Friday 9 am-9 pm; Saturday-Sunday 9 am-7 pm, EST.
or send e-mail:
consumerproducts@panasonic.com
For hearing or speech impaired TTY users, TTY: 1-877-833-8855

Web Site: <http://www.panasonic.com>
You can purchase parts, accessories or locate your nearest servicenter by visiting our Web Site.

Accessory Purchases:

1-800-332-5368 (Customer Orders Only)
For hearing or speech impaired TTY users, TTY: 1-866-605-1277
Panasonic Services Company 20421 84th Avenue South, Kent, WA 98032
(6 am to 5 pm Monday-Friday; 6 am to 10:30 am Saturday; PST)
(Visa, MasterCard, Discover Card, American Express, Check)

Service in Puerto Rico

Matsushita Electric of Puerto Rico, Inc. Panasonic Sales Company/Factory Servicenter:
Ave. 65 de Infantería, Km. 9.5, San Gabriel Industrial Park, Carolina, Puerto Rico 00985
Phone (787) 750-4300 Fax (787) 768-2910



INFO

- 1. Damage requiring service**—The unit should be serviced by qualified service personnel if:
 - (a) The AC power supply cord or AC adaptor has been damaged; or
 - (b) Objects or liquids have gotten into the unit; or
 - (c) The unit has been exposed to rain; or
 - (d) The unit does not operate normally or exhibits a marked change in performance; or
 - (e) The unit has been dropped or the cabinet damaged.
- 2. Servicing**—Do not attempt to service the unit beyond that described in these operating instructions. Refer all other servicing to authorized servicing personnel.
- 3. Replacement parts**—When parts need replacing ensure the servicer uses parts specified by the manufacturer or parts that have the same characteristics as the original parts. Unauthorized substitutes may result in fire, electric shock, or other hazards.
- 4. Safety check**—After repairs or service, ask the servicer to perform safety checks to confirm that the unit is in proper working condition.

The servicer will require all components to service your system.
Therefore, should service ever be necessary, be sure to bring the entire system.

Product information

For product information or assistance with product operation:

In the U.S.A., contact the Panasonic Customer Call Center at 1-800-211-7262, or e-mail consumerproducts@panasonic.com, or the website (<http://www.panasonic.com>).

In Canada, contact the Panasonic Canada Inc. Customer Care Centre at 1-800-561-5505, or visit the website (www.panasonic.ca), or an authorized Servicentre closest to you.

Listening caution



Selecting fine audio equipment such as the unit you've just purchased is only the start of your musical enjoyment. Now it's time to consider how you can maximize the fun and excitement your equipment offers. This manufacturer and the Electronic Industries Association's Consumer Electronics Group want you to get the most out of your equipment by playing it at a safe level. One that lets the sound come through loud and clear without annoying blaring or distortion—and, most importantly, without affecting your sensitive hearing.

We recommend that you avoid prolonged exposure to excessive noise.

Sound can be deceiving. Over time your hearing "comfort level" adapts to higher volumes of sound. So what sounds "normal" can actually be loud and harmful to your hearing.

Guard against this by setting your equipment at a safe level BEFORE your hearing adapts.

To establish a safe level:

- Start your volume control at a low setting.
- Slowly increase the sound until you can hear it comfortably and clearly, and without distortion.

Once you have established a comfortable sound level:

- Set the dial and leave it there.

Taking a minute to do this now will help to prevent hearing damage or loss in the future. After all, we want you listening for a lifetime.

Manufactured under license from Dolby Laboratories.
"Dolby", "Pro Logic" and the double-D symbol are trademarks of Dolby Laboratories.

Manufactured under license from Digital Theater Systems, Inc.
US Pat. No. 5,451,942, 5,956,674, 5,974,380, 5,978,762 and other world-wide patents issued and pending. "DTS" and "DTS Digital Surround" are registered trademarks of Digital Theater Systems, Inc. Copyright 1996, 2000 Digital Theater Systems, Inc. All rights reserved.

Apparatus Claims of U.S. Patent Nos. 4,631,603, 4,577,216, and 4,819,098, licensed for limited viewing uses only.

This product incorporates copyright protection technology that is protected by method claims of certain U.S. patents and other intellectual property rights owned by Macrovision Corporation and other rights owners. Use of this copyright protection technology must be authorized by Macrovision Corporation, and is intended for home and other limited viewing uses only unless otherwise authorized by Macrovision Corporation. Reverse engineering or disassembly is prohibited.



Common

Batteries	2
Center Focus	51
Cleaning	
Discs	6
Main unit	59
Video heads	59
Connection	
AC power supply cord	14
Cable TV	54
LINE IN/OUT	37, 53
Optional antenna connection	55
Speakers	11
Subwoofer	14
Television	12, 13
Custom Sound Memory	49
DTS	49, 50
Dolby Digital	49, 50
Dolby Pro Logic	49, 50
Headphones	48
Muting	48
Remote control mode	7, 8
Seat position	51
Sleep timer	48
Speaker level adjustments	51
Sound Field Control	49, 50
Source selector	7, 9
Subwoofer level	51
Super Surround	49, 50

DVD

A-B repeat play	21
All group play	25
Bitrate	30
CD text	22
Chapter Preview	19
Dialogue Enhancer	29
DIRECT NAVIGATOR	24
Double re-master	27
HighMAT	6, 23, 31
JPEG	22, 23, 31
Marker	21
MP3	22, 23, 31
On-Screen Menu Icons	28-30
Page Skip	20
Play list	24
Play speed	28
Position Memory	19
Program play	25
Progressive	13, 18
QUICK REPLAY	20
QUICK SETUP	17, 31
Random play	25
Ratings	31, 33
S-VIDEO	13
Region number	Cover
Repeat play	21
Resume	19
Rotating pictures	20

Settings	31-33
Soundtracks	26
Speaker delay time	33
Subtitles	26
TV Aspect	17, 31
TV Type	17, 31
WMA	22, 23, 31
Zoom	27

VCR

Auto bilingual choice function	45
Categories	41
Clock setting	
Auto clock setting	15, 42
Manual clock setting	42
Jet Navigator	40, 44
Jet rewind	34
Jet search	34, 44
MTS	44, 45
On-screen display	44, 45
Picture mode	35
Recording	
LINE IN	37
Timer recording	38
TV program	36
Repeat play	35
SAP	45
Settings	42-45
SQPB	5
TV channel tuning	
Antenna system	43
Auto tuning	43
Manual tuning	43
Plug-in Auto Tuning	15
Tape counter	45
Tape length	44
Tape speed	
Auto SP/EP change	39
EP	36
SP	36
VP	36
Tape's tab	5
Tracking	35
Vertical locking adjustment	35
VHS Index Search System (VISS)	41

TUNER

AM	
Antenna connection	14
FM	
Antenna connection	14, 47
Antenna plug	47
Frequency step	46

TV

Connection	12, 13
TV maker setting	16
TV operation	16

Panasonic Consumer Electronics
Company, Division of Matsushita
Electric Corporation of America
One Panasonic Way Secaucus,
New Jersey 07094
<http://www.panasonic.com>

Panasonic Sales Company,
Division of Matsushita Electric of
Puerto Rico, Inc. ("PSC")
Ave. 65 de Infantería, Km. 9.5
San Gabriel Industrial Park, Carolina,
Puerto Rico 00985

Panasonic Canada Inc.
5770 Ambler Drive
Mississauga, Ontario
L4W 2T3
www.panasonic.ca

