

Prepared Hocine BELKHOUDJA	Title CK5050 Datasheet		
Approved	Date 26/01/07	Revision 1.95	File CK5050_Datasheet_1.95

Hands Free Car Kit Module CK5050



Datasheet



Parrot

Product Scope

Parrot has identified a demand for the integration of the telephony into a host product like car radio or navigation system. The answer to this demand is **CK5050**.

The CK5050 is a feature-rich **Bluetooth Hands Free Car Kit** solution dedicated for the integration of Handsfree Bluetooth applications in car radios and car telematics systems.

1	PRODUCT OVERVIEW	3
1.1	CK5050 Features	3
2	ELECTRICAL ARCHITECTURE	4
2.1	CK5050 internal Block Diagram	4
2.2	Electrical Interfaces Characteristics	5
2.3	Main Connector Pinout	7
2.4	Application reference design (Analog interface)	8
2.5	Power consumption	9
2.6	Bluetooth Radio Link	9
3	HARDWARE LAYOUT	11
3.1	Components placement with internal antenna / Part Number PI040058/PI040059	11
3.2	Components placement with internal antenna / Part Number PI040064	13
4	SOFTWARE SPECIFICATIONS	15
4.1	Bluetooth Stack	15
4.2	Bluetooth Profiles Supported	15
4.3	Software Architecture	15
4.4	Software Interface	16
5	MECHANICAL DESIGN	17
6	DEVELOPMENT TOOLS	19
7	FCC REQUIREMENTS FOR MODULE APPLICATION	21

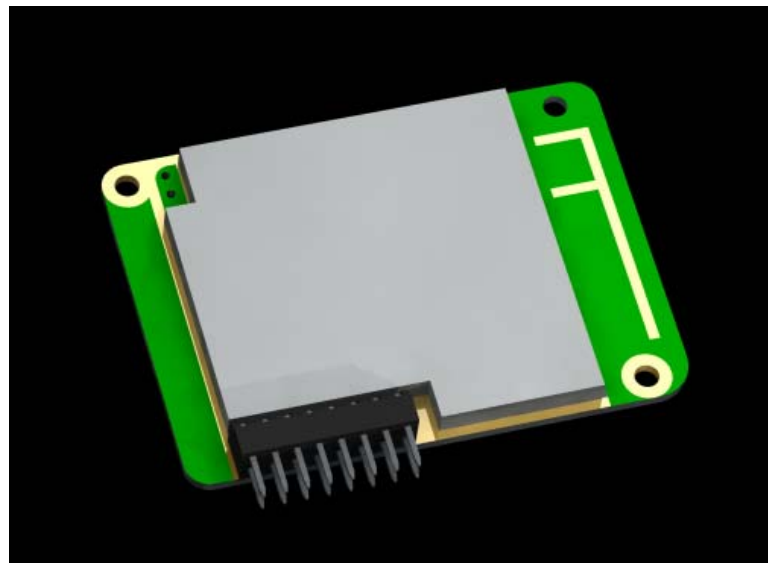

Prepared Hocine BELKHOUDJA	Title CK5050 Datasheet		
Approved	Date 26/01/07	Revision 1.95	File CK5050_Datasheet_1.95

1 Product Overview

This document is the Datasheet of the Parrot CK5050 Bluetooth Module. The CK5050 is a feature-rich Bluetooth platform dedicated for the integration of Bluetooth applications in car audios, car telematic systems or any systems requiring a complete embedded Bluetooth solution.

1.1 CK5050 Features

- **Bluetooth connectivity**
 - Bluetooth Power Class 2 Radio
 - Embedded Bluetooth v1.1 & v1.2 compliant
 - Embedded profiles
 - Compatible with all Bluetooth phones
 - Pairing and connection with all Bluetooth Devices: Phones, Smartphones, PDA ...
 - Multiple user support: Up to 5 paired phones
 - Multiple connection (up to 3 device connected at the same time)
 - Multiple profile (for example A2DP and HFP at the same time with same or different devices)
- **Phone**
 - Pick-up, Hang-up, Redial
 - Automatic answer (from host via dial command)
 - Send DTMF during calls
 - Private Mode
- **Phone Book**
 - Automatic Phone book synchronization over Bluetooth (up to 1000 names)
 - Call history (dialed number, received calls, missed calls)
 - All Synchronization Methods
 - Full Unicode for compatibility with numerous characters sets (European, Russian, Chinese, Japanese...)
- **Digital Signal Processing and Acoustics**
 - Acoustic Echo cancellation for Full Duplex operation
 - Noise reduction
 - Beam forming with 2 microphones inputs
 - Volume control
 - Speaker dependant voice recognition (trained names and keyword)
- **Audio Streaming**
 - Embedded SBC decoder
 - Embedded MP3 decoder from Thomson Licensing (optional)
 - Stereo audio output
- **Miscellaneous**
 - Provide Phone Battery Level and Network Level, Carrier Name (depends on phones)
 - Embedded test pattern
- **Software Update**
 - Full standard Software available (free upgrade from Parrot homepage)
 - Software update available through Bluetooth or UART
 - Very large compatibility with Phones, Smartphones, PDAs, Music players

2 Electrical Architecture

2.1 CK5050 internal Block Diagram

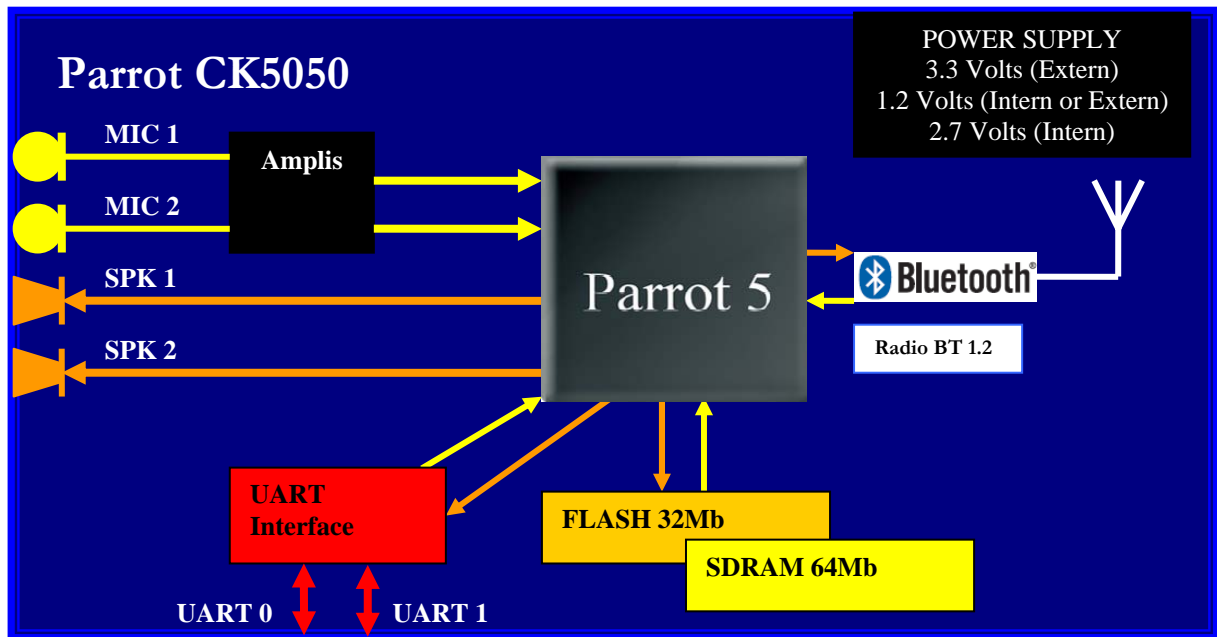

CK5050 Simplified Block Diagram

The main electrical interfaces provided by the CK5050 are:

- Audio
- Analog interface : 2 audio inputs + 1 stereo output
- Digital I2S interface : 1 stereo input + output
- Serial Link : UART for the software interface through AT commands (see "Host Software Interface specification")
- 3.3 V Power Supply
- Optional 1.2V Power Supply

2.2 Electrical Interfaces Characteristics

Absolute Maximum Rating				
	Min		Max	Unit
Supply Voltage	3,2		3.6	V
Ambiant Temperature	-40		+85	°C
Storage Temperature	-40		+125	°C

The P5 Asics core can operate at **208 MHz**.

▪ SERIAL LINK

- UART: 16C550 Compatible Type.
- 1 start bit, 1 stop bit, no parity
- The Least Significant Bit (LSB) is sent first.

▪ RESET

- Used to reset the Parrot Daughter Board, Active low. (maxVIL= 0.2V & minVIH= 2.5V).
- Switching ON/OFF procedures :

Switching on:

- The signal "NRESET" on the host interface is forced to a logical zero value by host until the supply voltage reached its nominal value.
During this phase no component on the module is supplied.
- The host switch its signal "NRESET" to a logical one value allowing the module to turn on its supply.
- After 280ms, the supply gets stabilized and then triggers the start of the ASIC
- 100ms is necessary for the ASIC to start and give execution to the embedded software that will turn the module into a permanent "active mode"

Switch off through software:

- The host sends the "sleep" AT command
- The ASIC disconnects any BT link
- The ASIC sends the "sleep acknowledge" AT command allowing the host to switch the reset to a zero logical value.
- If the host activate the "NRESET" to zero for at least 5 us but no more than 4ms the module will be reset.

▪ POWER

- VCC:
Supply voltage 3.3V(-0.1V/+0.3V) including tolerances, thermal changes, noise over/under shoot due to load change and/or car battery voltage change, load dump.
Peak current: 400 mA during switch on (2 ms).
- 1.2V OPTIONAL POWER SUPPLY:
This optional allows lower electrical power consumption of CK5050.
Operating Conditions: Supply Voltage for Logic Core: 1.2V (-0.04V/+0.12V)

▪ **AUDIO OUTPUT ⁽¹⁾:**

- SPK1: Output - left channel and SPK2: Output - right channel
 SPK1P (OUTL) and SPK2P (OUTR): The stereo channel would require two posts filtering of analog output. Outputs capable of driving a 10kOhms (min) load to 900 mV RMS.
 SPK1N and SPK2N: Middle reference Voltage (2V typ)
 See chapter 2.4: **Application reference design** for better result.
- Stereo I2S audio output channels

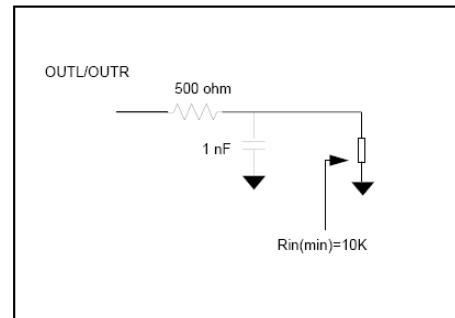

▪ **AUDIO INPUT :**

- MIC1N and MIC1P are differential input.
- Connect to electret condenser microphone
 Electrical characteristics of microphone:
 Impedance less than 2.2kOhms
 Operating voltage: 1.5V-3.6V DC
 Current consumption: 500μA max.
No need to put bias circuit.
- Stereo I2S audio input channels

▪ **BLUETOOTH RADIO LINK**

- Internal Bluetooth antenna

(1) Please note that MUTE function for car sound system is realized by software AT command

2.3 Main Connector Pinout

The following pinout allows an interface to the CK5050 according to market standards:

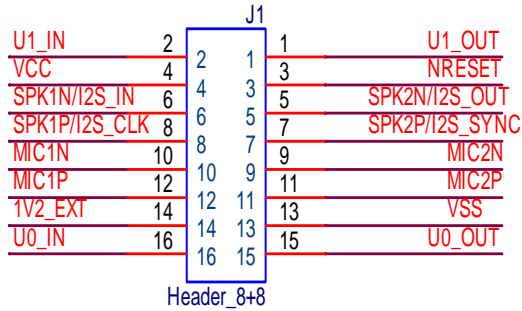

With Right angle Connector
PI040058/PI040064

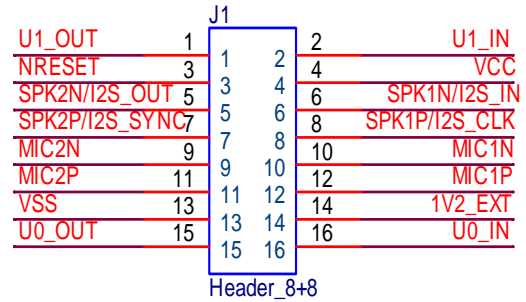

With vertical Connector
PI040059/PI040065

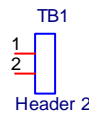

PIN	FUNCTION	INPUT / OUTPUT	COMMENT
1	UART1_OUT	O	16C550 Compatible type
2	UART1_IN	I	(for Debug interface)
3	NRESET	I	RESET trigger Input
4	VCC	I	POWER 3.3V
5	SPK2N/I2S_OUT	O	Analogical & Digital audio output Digital audio input
6	SPK1N /I2S_IN	O/I	
7	SPK2P/I2S_SYNC	O	
8	SPK1P/I2S_CLK	O	
9	MIC2N	I	Analogical audio input
10	MIC1N	I	
11	MIC2P	I	
12	MIC1P	I	
13	Vss	I	Vss (GROUND)
14	1V2_EXT	I	Option: 1V2 Extern
15	UART0_OUT	O	16C550 Compatible type
16	UART0_IN	I	(for Host AT commands and Flash Update interface)

PIN	FUNCTION	INPUT / OUTPUT	COMMENT
1	TB1	I	Connect to Vss (Ground of CK5050 module) if necessary
2	TB1	I	
-	Hole 1	I	
-	Hole 2	I	
-	Hole 3	-	Mechanical only if necessary

2.4 Application reference design (Analog interface)

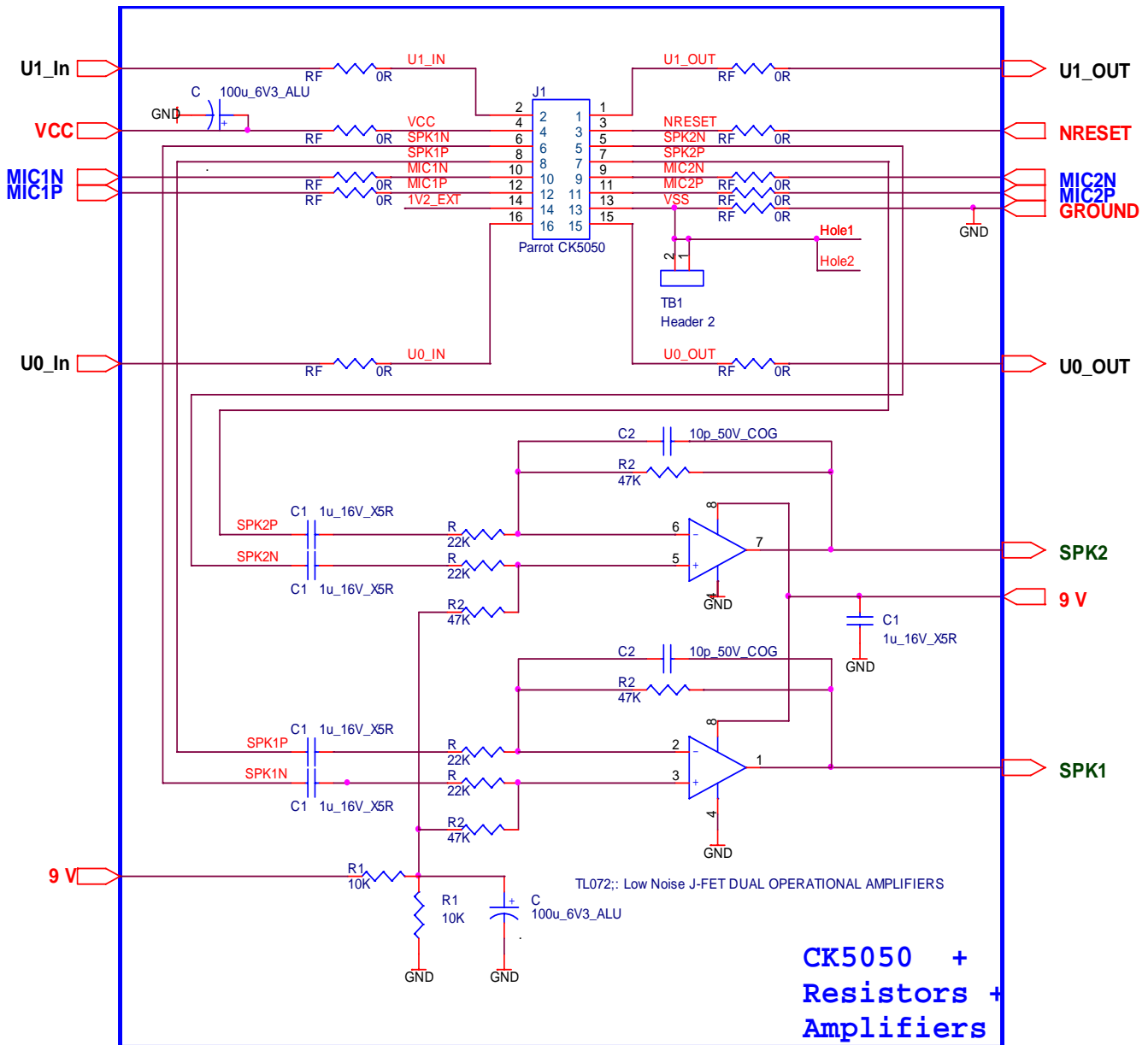

- Audio Pins SPK1P, SPK1N, SPK2P, SPK2N, MIC1P, MIC1N, MIC2P and MIC2N must be protect against noise by ground.
- U0_In, U0_Out, U1_In and U1_Out are noisy signal.
- Isolate U0_In, U0_Out, U1_In, U1_Out, MIC1P, MIC1N, MIC2P, MIC2N, VCC, NRESET and VSS by 0R resistors (RF: 0603) and use ferrites in case of ECM disturbances.

2.5 Power consumption

The CK5050 features one optional 1.2V power supply on an additional pin
This optional allows lower electrical power consumption.

FUNCTIONING MODES	WITHOUT 1.2V PIN CURRENT ON 3.3V	WITH 1.2V PIN CURRENT ON PINS		REMARKS
		3.3V	1.2V	
STOP MODE	<50 μ A	-	-	BT radio and Parrot5 ASIC stopped, Internal voltage regulator switched off.(Power off or Reset active)
STANDBY MODE	<130 mA	< 120 mA	< 10 mA	BT module in sniff mode, Parrot ASIC in idle
HANDSFREE MODE	<250 mA	< 150 mA	< 100 mA	Handsfree communication with a Bluetooth enabled phone
AUDIO STREAMING	<280 mA	< 160 mA	< 120 mA	Reception of an encoded stream, decoding, playing of the audio

2.6 Bluetooth Radio Link

2 different configurations available:

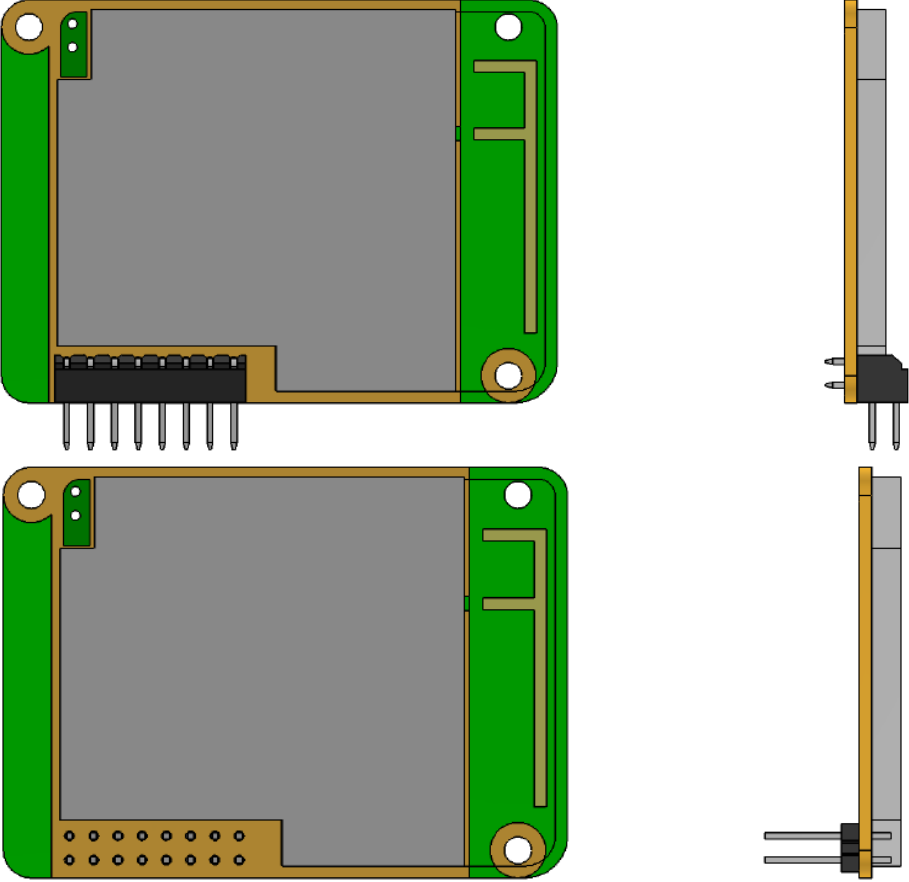
CONFIG 1 / PART NUMBER PI040058/ PI040059
Embedded BT Antenna on PCB Module
The most efficient & cost effective integration



CONFIG 1 / PI040064

Embedded BT Antenna on PCB Module

The most efficient & cost effective integration

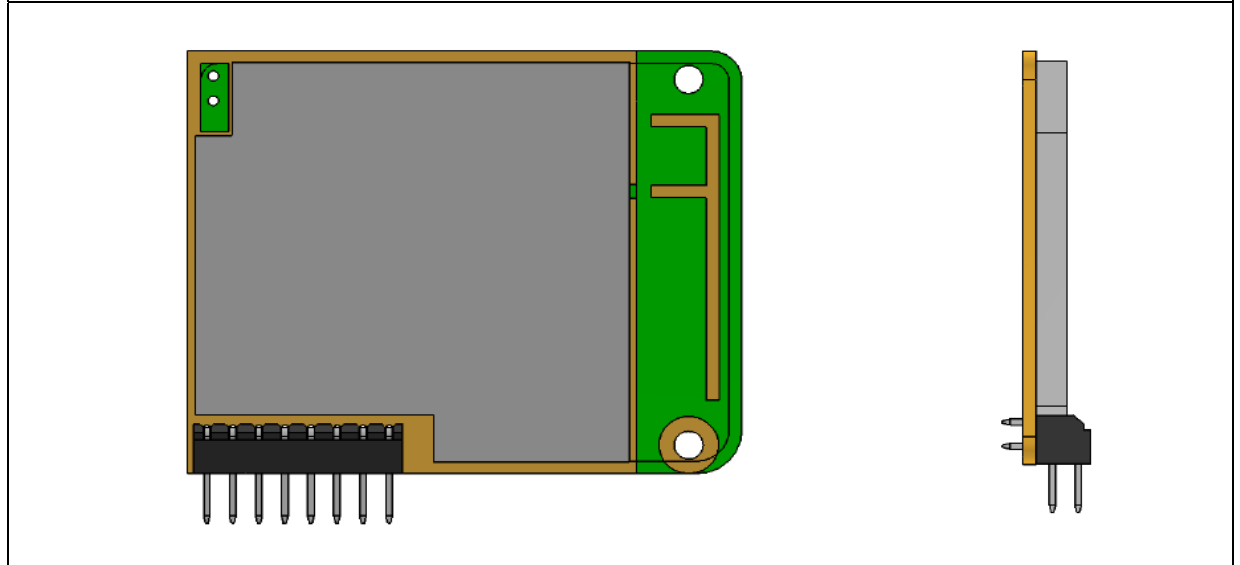

3 Hardware layout

3.1 Components placement with internal antenna / Part Number PI040058/PI040059

Details:

U1: Parrot5 ASIC (BGA) + **U2/U3:** SDRam/Flash (BGA) + **U100:** BT radio transceiver (QFN) + **U200:** 2V7 Voltage regulator (Sot23) + **U201:** 1V2 Voltage regulator (DFN8) + **U202:** Voltage supervisor (Sot23) + **U300:** Operational Amplifiers (TSSOP) + **X100:** Precision crystal oscillator + **J1:** Main connector + **TB1:** 2 pin connector.

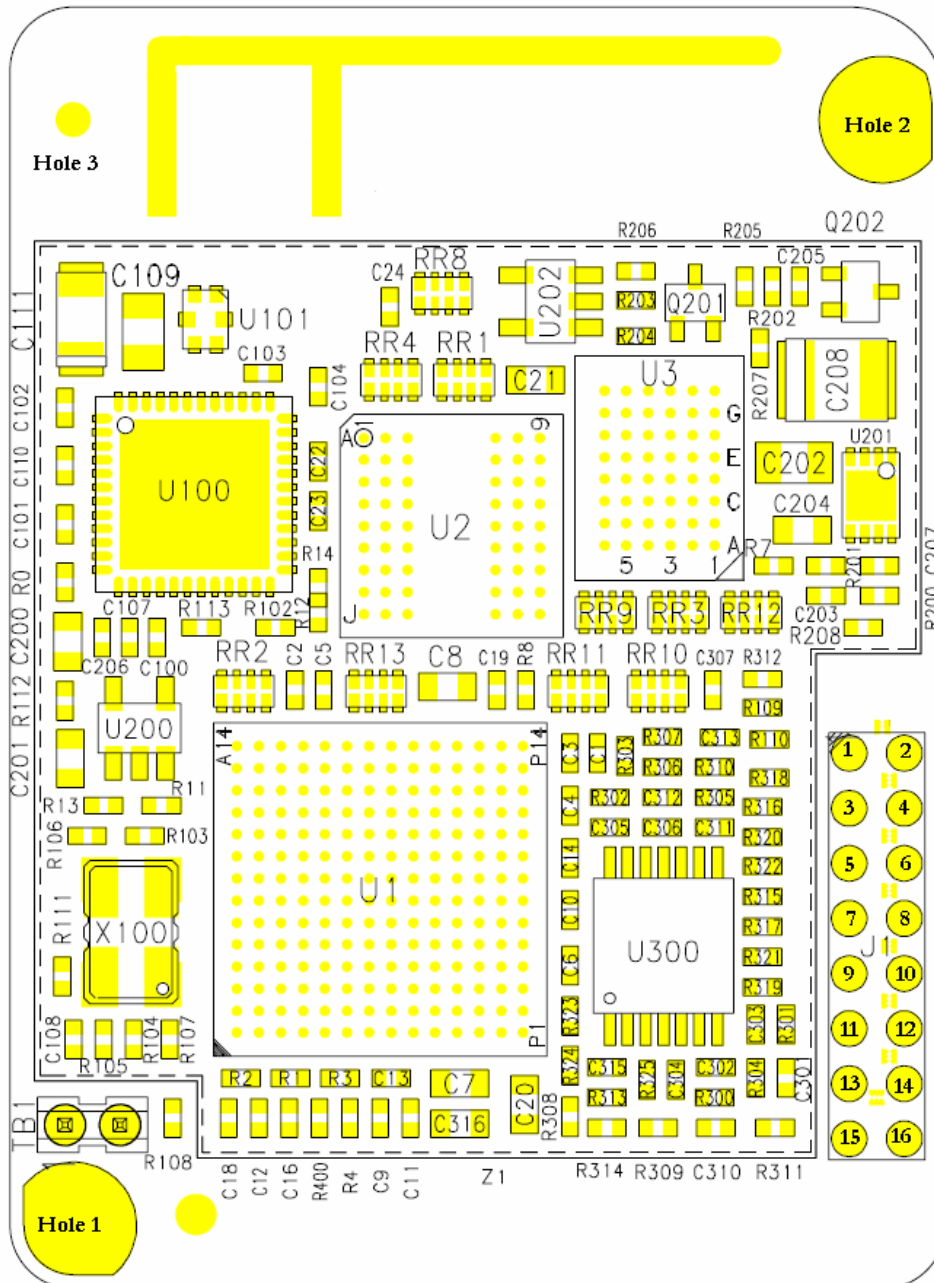

COMPONENTS SIDE (TOP)

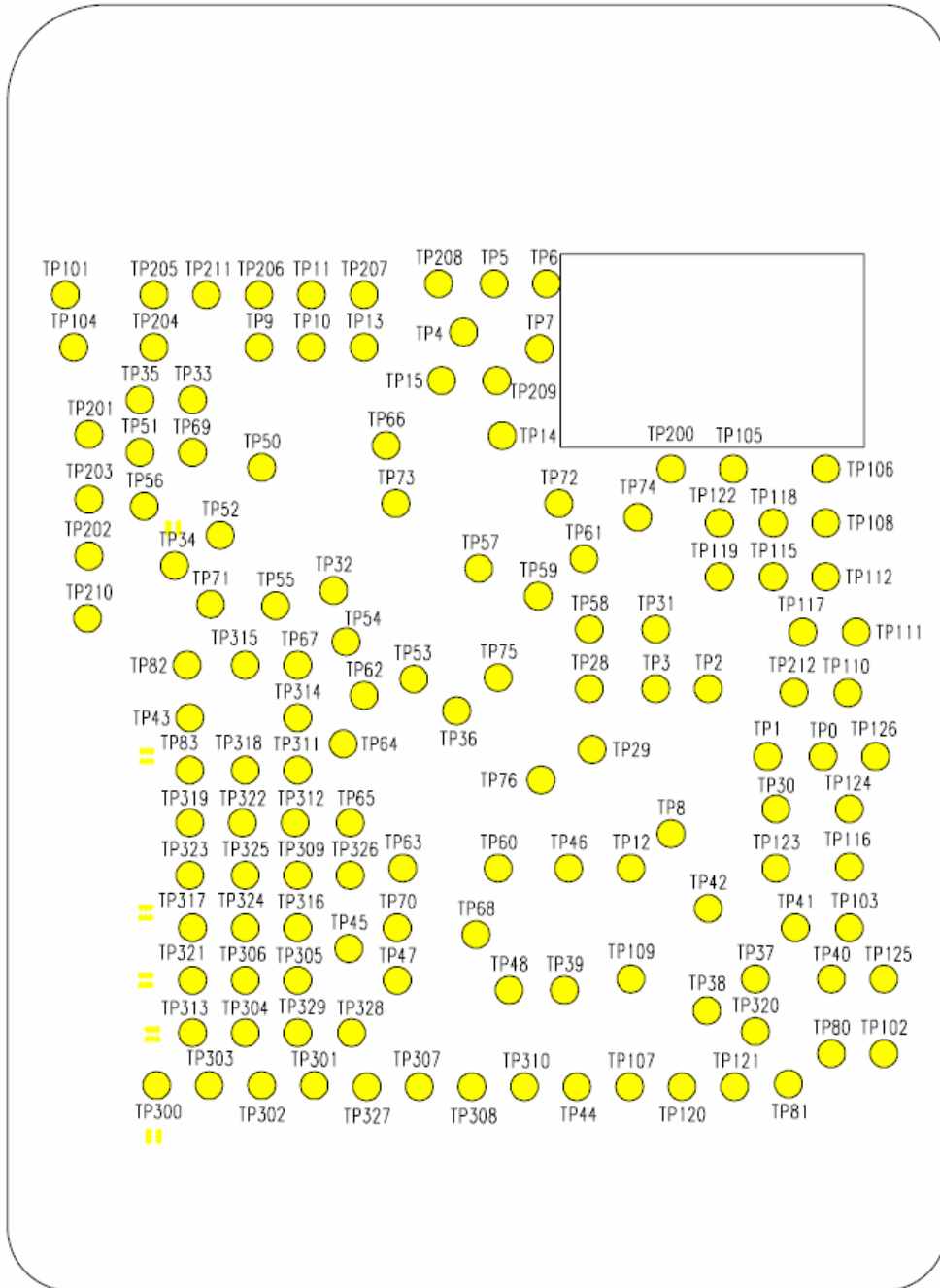

BOTTOM SIDE (135 Tests Points)

PCB size: 34mm x 46.55mm **Tolerances +/- 0.1 mm**

3.2 Components placement with internal antenna / Part Number PI040064

Details:

U1: Parrot5 ASIC (BGA) + **U2/U3:** SDRam/Flash (BGA) + **U100:** BT radio transceiver (QFN) + **U200:** 2V7 Voltage regulator (Sot23) + **U201:** 1V2 Voltage regulator (DFN8) + **U202:** Voltage supervisor (Sot23) + **U300:** Operational Amplifiers (TSSOP) + **X100:** Precision crystal oscillator + **J1:** Main connector + **TB1:** 2 pin connector.

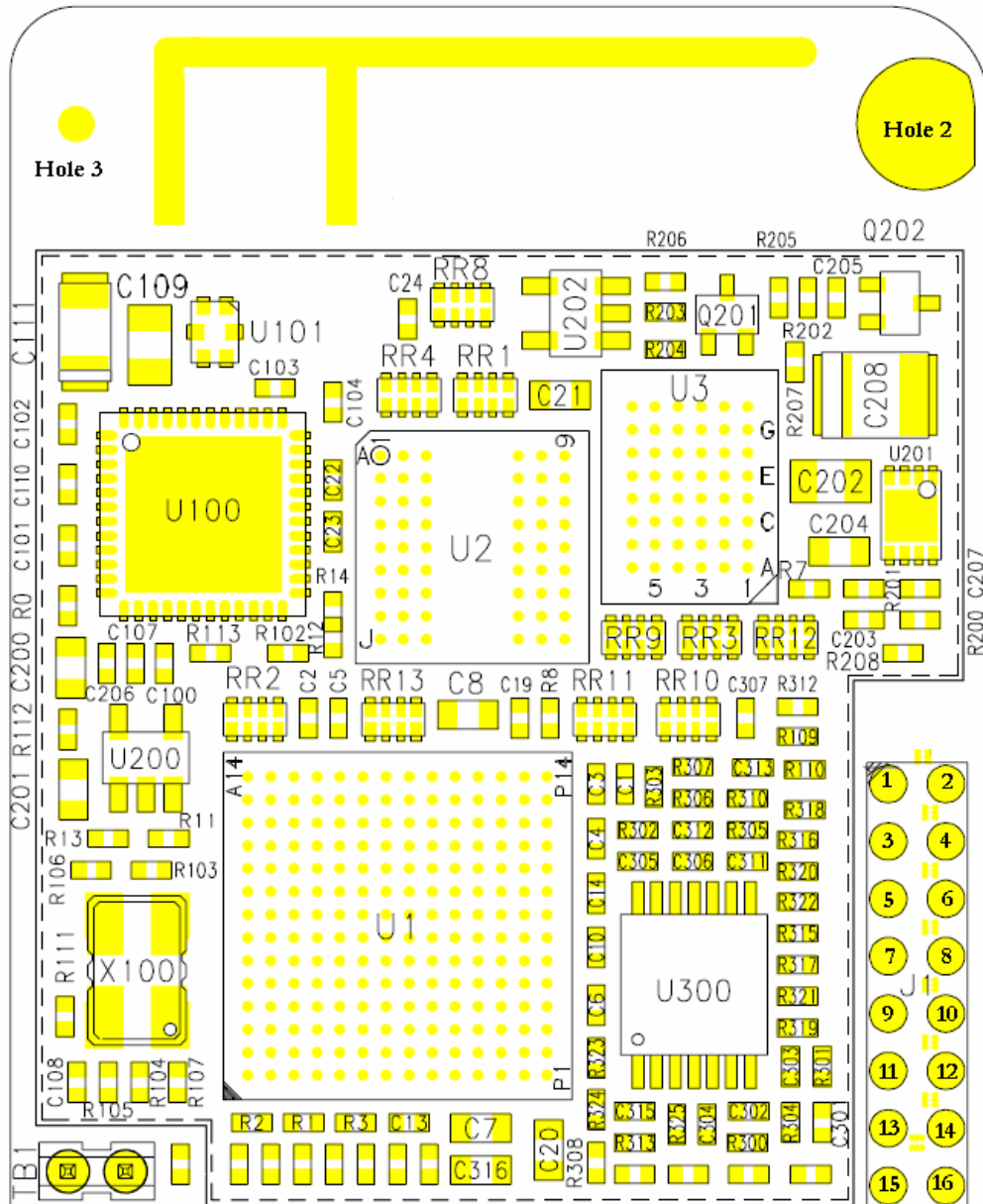

COMPONENTS SIDE (TOP)

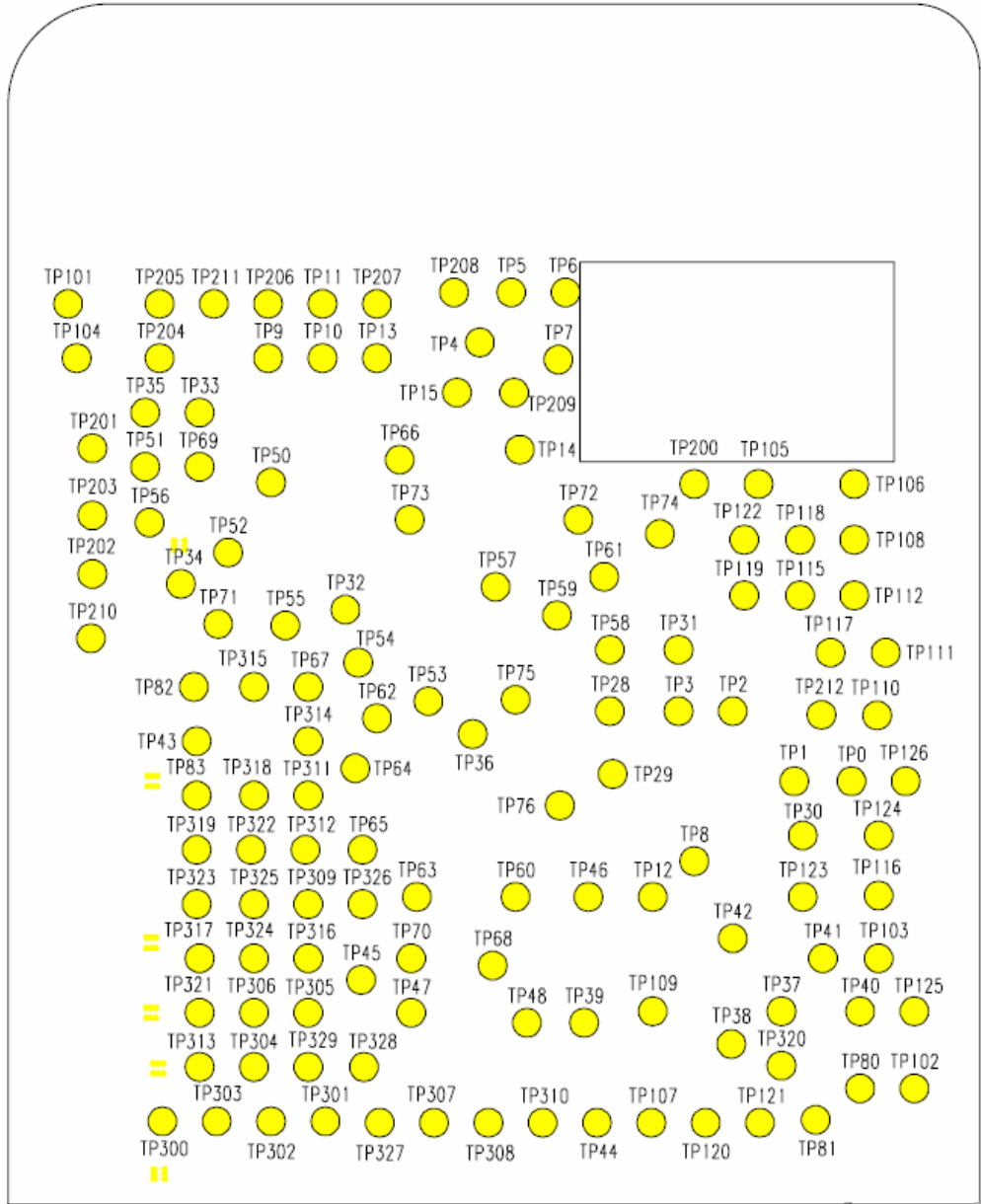

BOTTOM SIDE (135 Tests Points)

PCB size: 34mm x 42.6mm **Tolerances +/- 0.1 mm**

Prepared Hocine BELKHOUDJA	Title CK5050 Datasheet		
Approved	Date 26/01/07	Revision 1.95	File CK5050_Datasheet_1.95

4 Software Specifications

4.1 Bluetooth Stack

- HCI (Host Controller interface),
- L2CAP (Logical Link Control and Adaptation Protocol),
- RFCOMM (TS011...),
- SDP (Service Discovery Protocol),
- OBEX (IrDA Object Exchange).



4.2 Bluetooth Profiles Supported

- Generic Access Profile
- GAP
- Phone Management
 - HFP 0.96 - 1.0 - 1.5
 - HSP 1.0
- Message Management
 - MAP 1.0
- Phone Book
 - PBAP 1.0
 - SYNC 1.1 (IrMC SYNC over BT)
 - OPP 1.0 Server/Client (Vcard 2.1)
 - GSM 07.07 AT Commands
 - Nokia synchronization protocol
- Multimedia
 - A2DP (Audio)
 - SBC decoding
 - (optional MP3 decoding)
 - AVRCP
- Others
 - SPP 1.1
 - Image transfer over OPP
 - DUNP 1.1
 - Software update over SPP
 - Remote configuration

4.3 Software Architecture

See Bluetooth Stack Software Specification (Confidential).

Prepared Hocine BELKHOUDJA	Title CK5050 Datasheet		
Approved	Date 26/01/07	Revision 1.95	File CK5050_Datasheet_1.95

4.4 Software Interface

The main target of the software interface is to provide a high level command set, hiding the internal complexity of the Bluetooth function and the variability of its standard across different devices.

This software interface is based on well-known AT commands. Some of these commands are directly derived from the GSM 07.07 recommendation and from the appropriate Bluetooth profiles.

Some supplementary commands are used to manage Bluetooth related functions like device pairing and connection management as well as the acoustic and speech recognition functions.

AT Command List and Bluetooth AT Command Software Specification is available.

BLUES supports Unicode, which allows the management of accents and phonebook in any language.

BLUES is also very friendly with a flexible MMI. One can use BLUES with a simple single or double key interface as well as a diversity of graphic displays.

Prepared Hocine BELKHOUDJA	Title CK5050 Datasheet		
Approved	Date 26/01/07	Revision 1.95	File CK5050_Datasheet_1.95

5 Mechanical Design

The CK5050 features a male connector allowing a connection to the motherboard through a female connector or by through hole soldering (CK5050 soldered vertically - wave soldering is possible).

Board to Board Main Connector

- 16 PIN connector + 2 x 2 Pin connector
- 2mm pitch double row (2x8 and 2x1)
- Right Angle (**MOLEX 87760-1618**) / Upright connector (**MOLEX 87758-1618 CKTS, 87758-1618(specific) and 87758-0218 (specific)**)

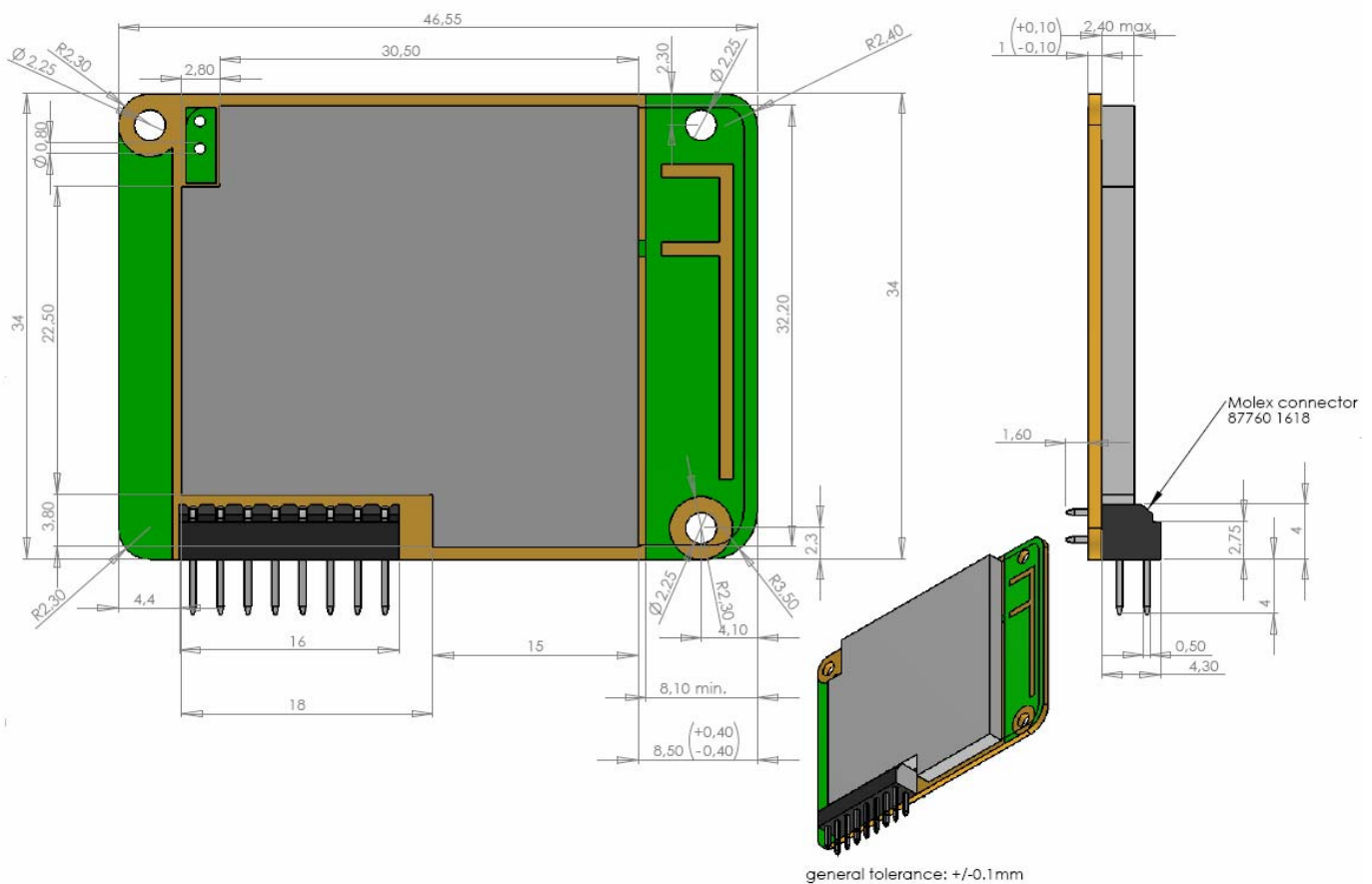

Mechanical dimensions (Tolerances -0.1/0.1 mm) with internal BT antenna and Right angle connector
Part Number PI040058

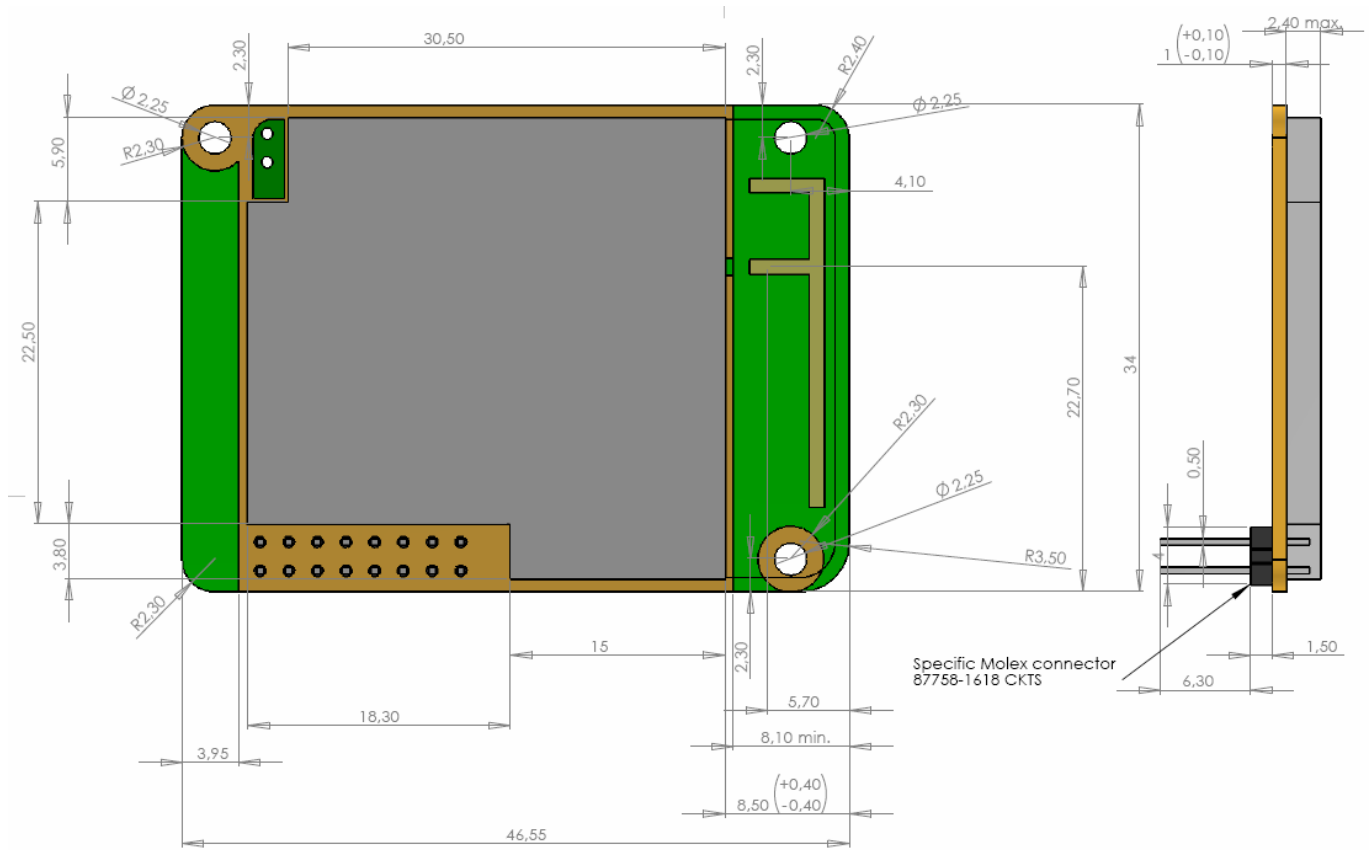

Mechanical dimensions (Tolerances -0.1/0.1 mm) with internal BT antenna and Vertical Connector
Part Number PI040059

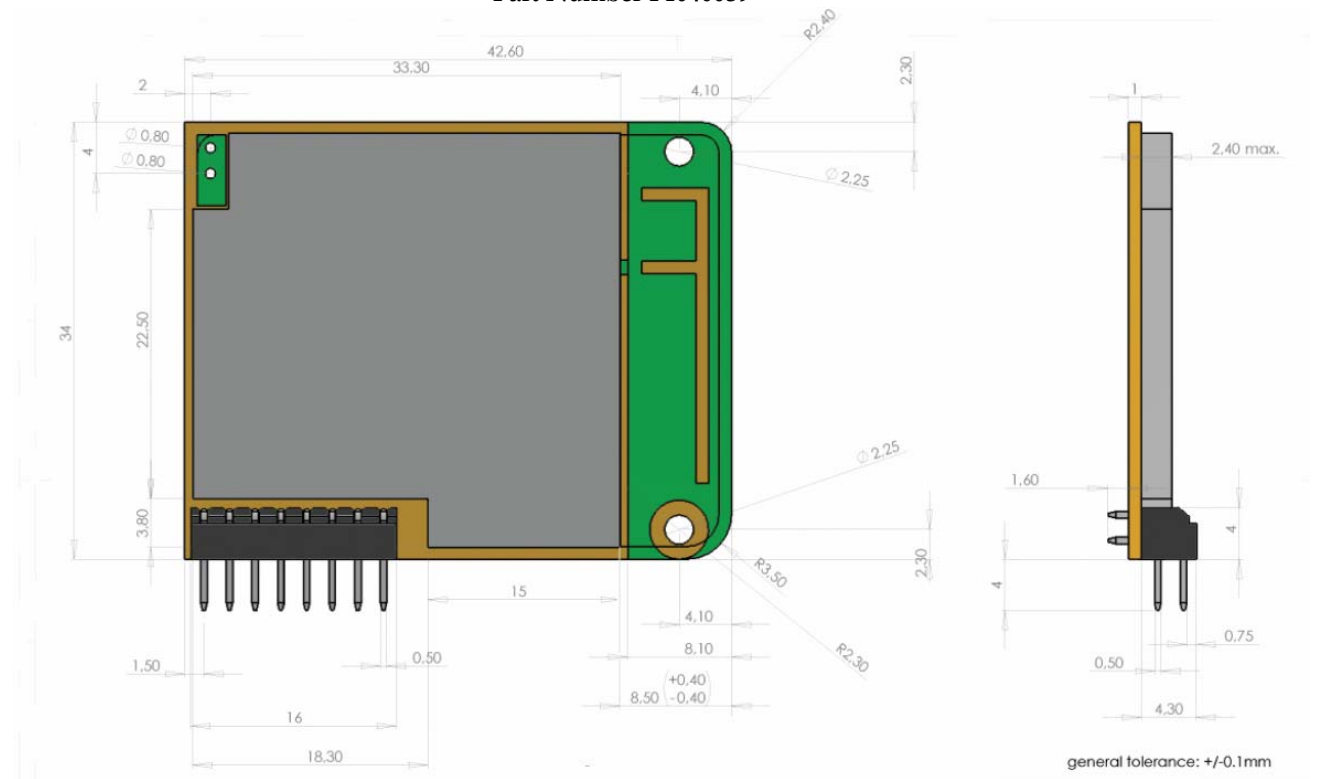

Mechanical dimensions (Tolerances -0.1/0.1 mm) with internal BT antenna and Right angle connector
Part Number PI040064

6 Development Tools

- Demo board available
- Host Software Interface specification
- Host software example with C++ source code.

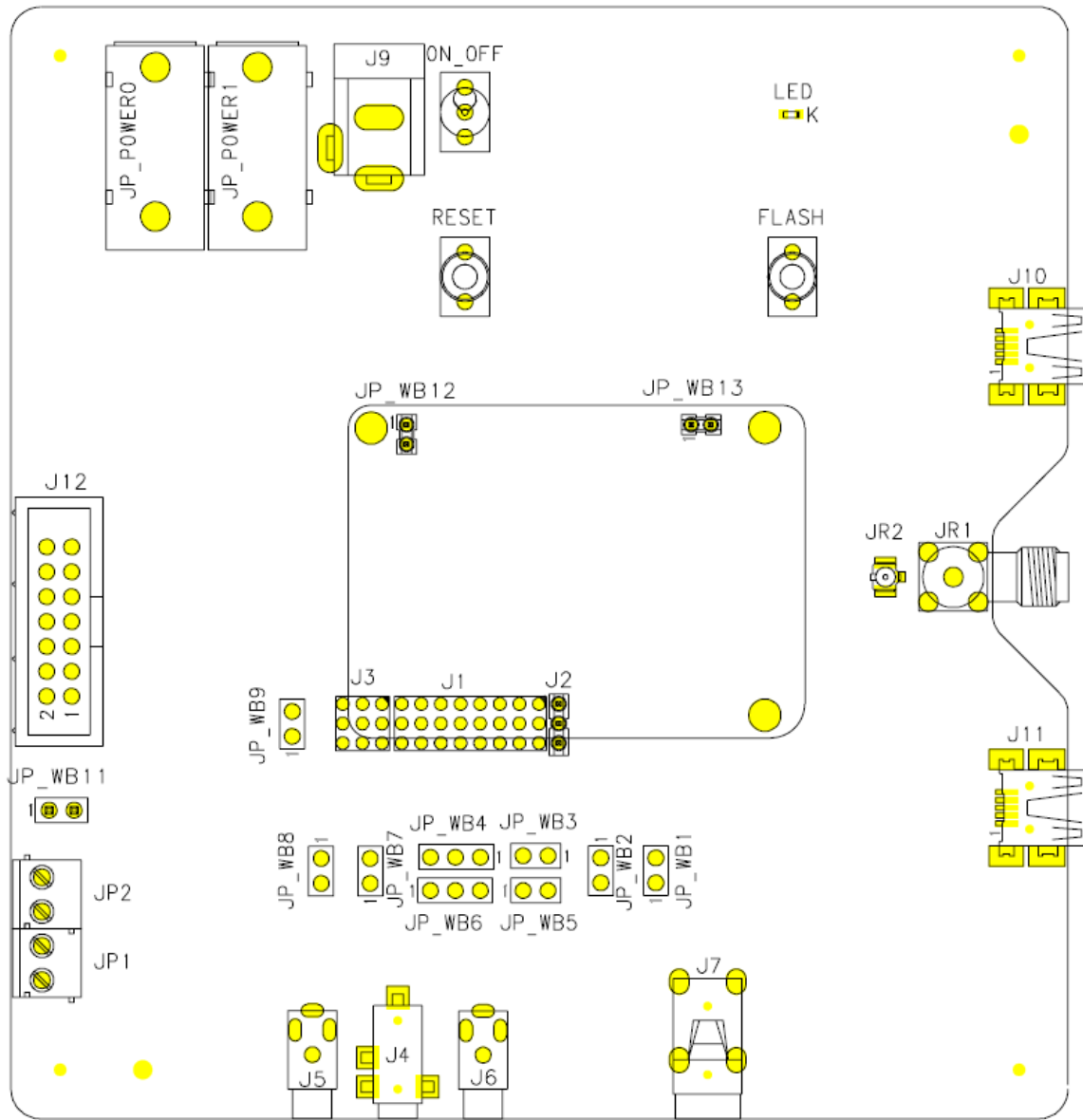

CK5050 WORKBENCH/TOP SIDE VIEW

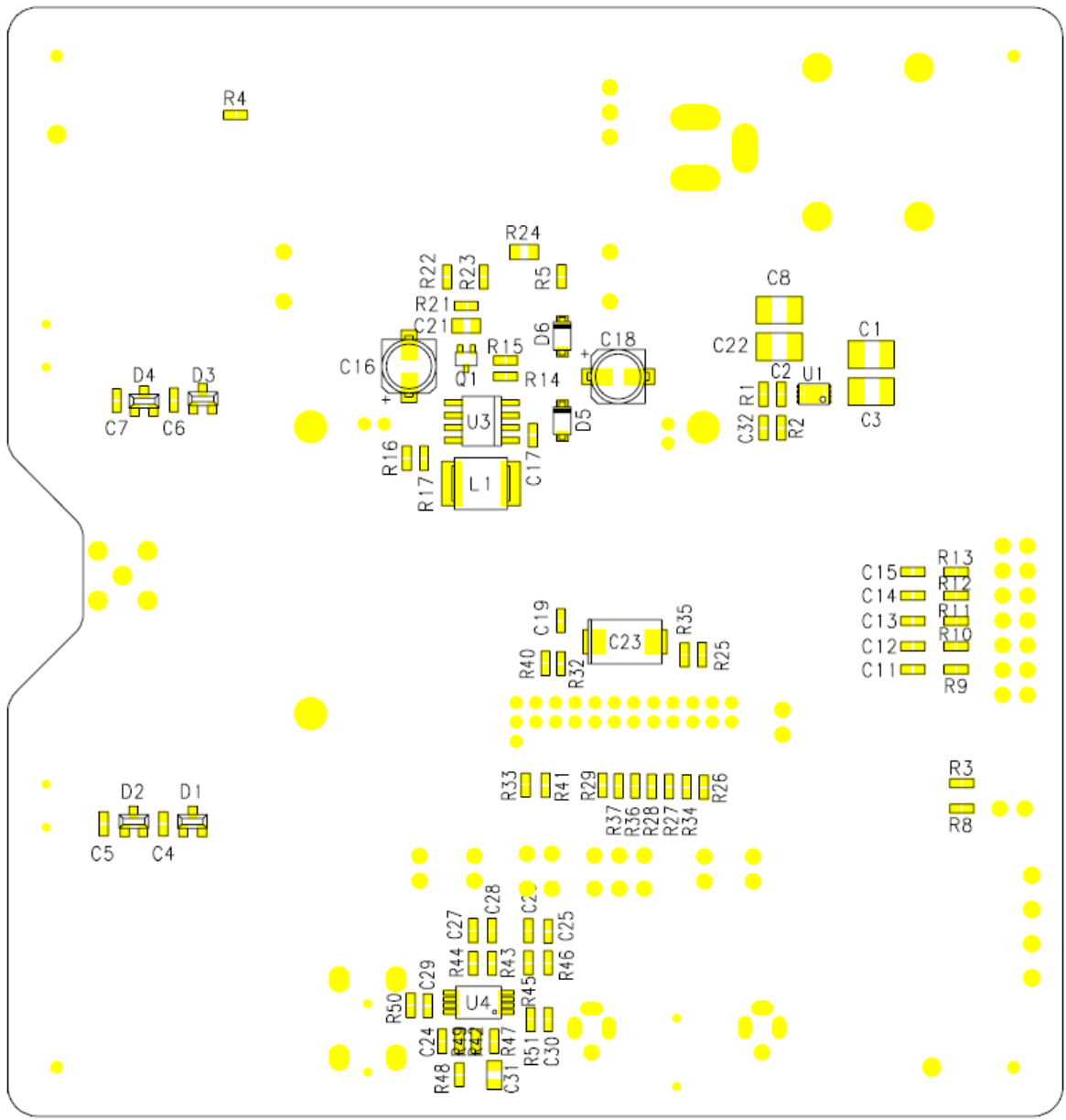

CK5050 WORKBENCH/BOTTOM SIDE VIEW

Prepared Hocine BELKHOUDJA	Title CK5050 Datasheet		
Approved	Date 26/01/07	Revision 1.95	File CK5050_Datasheet_1.95

7 FCC Requirements for module application

- The applicant of the final device into which the module CK5050 is installed is not required to obtain a new authorization for this. Moreover, module CK5050 is also submitted to CE mark, Bluetooth certification, and is considered as an automotive product. This product respects FCC part 15 C requirements for a Bluetooth application.
- Module CK5050 is labelled with its own FCC number on its shielding, and, if the FCC ID is not visible when the module is installed inside final device, then the outside of the device into which the module is installed must also display a label referring to the enclosed module. This exterior label can use wording such as the following: "Contains Transmitter Module FCC ID: RKXCK5050" or "Contains FCC ID: RKXCK5050." Any similar wording that expresses the same meaning may be used.
- Module CK5050 can not be integrated in a final device which is connected to the AC power lines. It is necessary that final device must be supplied by a battery.
- FCC RF exposure requirements: This device and its antenna(s) must not be co-located or operating in conjunction with any other antenna or transmitter.
- THIS DEVICE COMPLIES WITH PART 15 OF THE FCC RULES. OPERATION IS SUBJECT TO THE FOLLOWING TWO CONDITIONS:
 - (1) THIS DEVICE MAY NOT CAUSE HARMFUL INTERFERENCE, AND
 - (2) THIS DEVICE MUST ACCEPT ANY INTERFERENCE RECEIVED, INCLUDING INTERFERENCE THAT MAY CAUSE UNDESIRE OPERATION.

NOTE: THE MANUFACTURER IS NOT RESPONSIBLE FOR ANY RADIO OR TV INTERFERENCE CAUSED BY UNAUTHORIZED MODIFICATIONS TO THIS EQUIPMENT. SUCH MODIFICATIONS COULD VOID THE USER'S AUTHORITY TO OPERATE THE EQUIPMENT.



DECLARATION OF “ CE “CONFORMITY “PARROT CK5050 “

We, Parrot SA 174 quai de Jemmapes 75010 Paris France, declare under our sole responsibility that our product (**Parrot CK5050**) is in conformity with the Radio and Telecommunication equipment directive **1999/5/EC R&TTE** according to the essentials requirements and respect the norms listed below :

- | | |
|---------------------------------------|--------------------------|
| 1) EN60950-1 (2001) | Electrical Safety |
| 2) EN301 489-17 V.1.2.1 (2002) | EMC |
| 3) EN300 328 V.1.6.1 (2004) | Radio |
| 4) EN50371 (2002) | EMF |

Paris, January 10th , 2007

Qualification Manager

Arezki Guerrab



Parrot RCS Paris B 394149496 – S.A. au capital de 1 903 100,67 €.- NAF : 322B
 174, quai de Jemmapes - 75010 Paris - Tel: +33 (0)1 48 03 60 60 - Fax: +33 (0)1 48 03 06 66 – Internet : www.parrot.biz – www.voice-assistant.com
 N° ID-TVA : FR 70 394 149 496 000 25