

PARROT PRODUCT DATASHEET



Parrot

FC6000

Version 1.7

March 2012

Confidential Information

Parrot FC6000

All in one multimedia module
Bluetooth 3.0

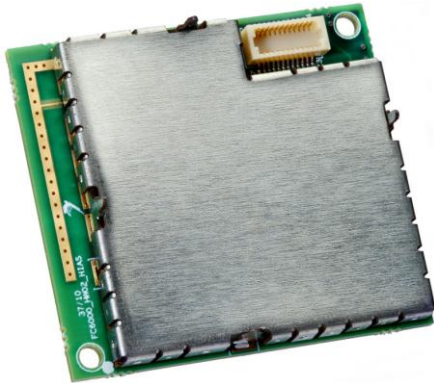

Version 1.7
March 2012

Application:

- Telephony
- Internet access (through DUN or PAN)
- Audio Streaming
- Voice Recognition / Text To Speech

The FC6000 integrates the latest version of the Parrot Bluetooth stack (Blues). Blues gives to the customer a very high level of compatibility with most of the phones available on the market and provide phonebook and list synchronization. FC6000 offers the possibility to use a Speaker Independent Voice Recognition (SIVR) and a Text To Speech algorithm (TTS).

FEATURES

Bluetooth 3.0 qualified module
3.3V & 1.8V power supply, UART, I²S
GPIO
Digital audio input and output
Analog microphone input
Analog output
Up to 10 paired phones
Small size module (32 x 36 mm)
Automotive qualified

Description:

Parrot FC6000 is a fully integrated Bluetooth phone connectivity solution powered by a Parrot P6i with 416 MIPS with an internal CODEC and NR/AEC signal processing. It integrates a large variety of interfaces for an easy integration in most of the applications.

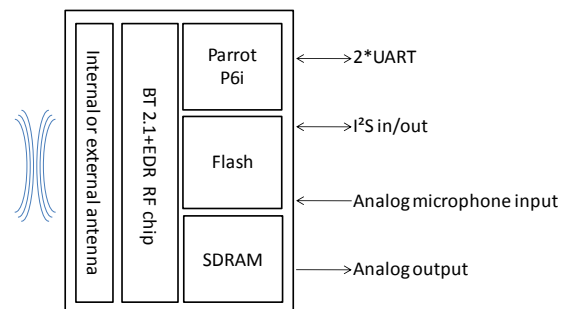

Table of contents

1	PRODUCT OVERVIEW	5
2	SOFTWARE SPECIFICATIONS	8
2.1	BLUETOOTH STACK.....	8
2.2	BLUETOOTH PROFILE SUPPORTED.....	8
2.3	SOFTWARE INTERFACE	9
2.4	MEMORY CONFIGURATIONS	9
2.5	SPEAKER INDEPENDENT VOICE RECOGNITION	10
2.5.1	<i>Voice Recognition principles</i>	10
2.5.2	<i>Text To Speech (TTS)</i>	11
3	ELECTRICAL SPECIFICATIONS	12
3.1	HARDWARE ARCHITECTURE.....	12
3.2	PIN-OUT	12
3.2.1	<i>Pin-out diagram</i>	12
3.2.2	<i>Pinout table</i>	13
3.2.3	<i>Unconnected pins advice</i>	14
3.3	ABSOLUTE MAXIMUM RATINGS	15
3.4	POWER CONSUMPTION (T°=25°C, 1V8 PROVIDED BY LDO MPS2002)	15
3.4.1	<i>Power consumption on 3V3 Power Supply</i>	15
3.4.2	<i>Power consumption on 1V8 Power Supply</i>	15
3.5	ELECTRICAL CHARACTERISTICS	15
3.5.1	<i>Power pins</i>	15
3.5.2	<i>IO pins</i>	15
3.5.3	<i>UART_AT/UART_DBG</i>	16
3.5.4	<i>I2S IO</i>	17
3.5.5	<i>Audio</i>	19
3.5.6	<i>Bluetooth radio link</i>	21
3.6	RESET AND SUPPLY SEQUENCE DIAGRAM	22
3.7	FLASH UPDATE SEQUENCE DIAGRAM.....	23
3.8	POWER OFF SEQUENCE DIAGRAM.....	23
3.8.1	<i>Power supplies reference design</i>	24
4	MECHANICAL SPECIFICATIONS	25
4.1	HORIZONTAL MODULE WITH EXTERNAL ANTENNA.....	25
4.2	HORIZONTAL MODULE WITH INTERNAL ANTENNA.....	26
4.3	VERTICAL MODULE WITH EXTERNAL ANTENNA	27
4.4	VERTICAL MODULE WITH INTERNAL ANTENNA.....	28
4.5	MODULE CONNECTORS.....	29
4.5.1	<i>Connector on mother board</i>	29
4.5.2	<i>Horizontal modules connector</i>	30
4.5.3	<i>Vertical modules connector</i>	31
4.5.4	<i>Antenna connector</i>	32
4.6	MOTHERBOARD MECHANICAL INTEGRATION	33
4.6.1	<i>Mechanical integration – Horizontal version:</i>	33
4.6.2	<i>Mechanical integration – Vertical version:</i>	34
5	AVAILABLE TOOLS	35
5.1	WORKBENCH.....	35
5.1.1	<i>Diagram</i>	35
5.1.2	<i>Schematics</i>	36
5.2	WXHIPHOP.....	37
5.3	WXFLASHER.....	37

6	APPROVAL / CERTIFICATIONS	38
6.1	FC6000S	38
6.1.1	<i>CE Declaration</i>	<i>38</i>
6.1.2	<i>FCC and IC requirements for module application</i>	<i>39</i>
6.2	FC6000N	40
6.2.1	<i>CE Declaration</i>	<i>40</i>
6.2.2	<i>FCC and IC requirements for module application</i>	<i>41</i>
7	USE CASES.....	42
A.	BLUETOOTH HFP & A2DP/AVRCP USE CASES OVERVIEW:	42
a.	<i>Head Unit paired with Mobile phone.....</i>	<i>42</i>
b.	<i>Head Unit connected to Mobile phone and headset device</i>	<i>44</i>
c.	<i>Head Unit paired with two Mobile phones.....</i>	<i>45</i>
d.	<i>Audio Streaming and Handsfree working together</i>	<i>46</i>
e.	<i>Head Unit paired with Mobile phone and Music Player with BT integrated or Bluetooth dongle:</i>	<i>48</i>
f.	<i>Head Unit paired with a stereo Headphone</i>	<i>49</i>
g.	<i>Head Unit paired with Mobile phone: Data transfer</i>	<i>50</i>
B.	HEAD UNIT BT/UART SOFTWARE UPDATE.....	51

1 Product overview

The FC6000 is a feature-rich Bluetooth platform dedicated for the integration of Bluetooth in car audios, car telematics systems or any systems requiring a complete embedded multimedia solution.



FC6000 features are:

- **Bluetooth connectivity**
 - Bluetooth Power Class 2 Radio
 - Embedded Bluetooth .1, v1.2, v2.0+EDR, v2.1+EDR & v3.0 compliant
 - Embedded profiles
 - Compatible with most of Bluetooth phones
 - Pairing and connection with all Bluetooth Devices: Phones, Smartphones, PDA ...
 - Multiple users support: Up to 10 paired phones depending on Flash memory size.
 - Multiple connections (up to 3 device connected at the same time)
 - Multiple profiles
- **Phone**
 - Pick-up, Hang-up, Redial
 - Automatic answer (from host via pickup command)
 - Send DTMF during calls
 - Private Mode
 - 3-way calling
 - Double HFP

- **Phone Book**
 - Automatic Phone book synchronization over Bluetooth (up to 5000 contacts; depending on the Flash memory size)
 - Call history (dialed number, received calls, missed calls)
 - All Synchronization Methods
 - Full Unicode for compatibility with numerous characters sets (European, Russian, Chinese, Japanese...)

- **Digital Signal Processing**
 - Microphone(s): the module can manage two configurations:
 - Single microphone
 - Two microphones with AMS (Automatic Microphone Selection): 1 for the driver and 1 for the front seat passenger. The best microphone is automatically selected during the call.
 - Noise Reduction (NR)
 - Maximal NR is 25dB.
 - Typical NR is 15dB.
 - No musical noise
 - No fluctuation of the residual noise level
 - Automatic adaptation of the Noise Reduction to the Signal-to-noise ratio (SNR) to keep the best voice quality in idle and remove more noise in noisy conditions.
 - Acoustic Echo Cancellation (AEC)
 - The level of echo attenuation, called ERLE is 45dB (measured according to the VDA process).
 - Comfort Noise feature so that the background noise is adjusted after AEC algorithm, in order to keep it constant for enhanced communication experience.
 - Possibility to accept up to 100ms of delay in the speaker path for digital amplifiers.
 - Full duplex
 - Automatic Level Control (ALC)
 - Different phones can have different Speaker volumes (up to 20dB of difference). It adapts the signal level received from the phone to the target level, quickly and precisely.
 - Equalizer
 - 9 bands equalizer for microphones and speaker paths.
 - Tuning
 - Car independent tuning if the microphone position and specifications are the same.
 - Possibility to tune all parameters of the audio algorithms according to Customer preferences.
 - Wideband
 - All algorithms work @ 16 kHz.

- **Audio Streaming**
 - Embedded SBC decoder
 - Embedded MP3 decoder from Thomson Licensing (optional)
 - Stereo audio output

- **Speaker Independent Voice Recognition (Optional)**

- **Text To Speech (Optional)**

- **Miscellaneous**
 - Provide Phone Battery Level and Network Level, Carrier Name (depends on phones)
- **Software Update**
 - Full standard Software available (free upgrade from Parrot homepage)
 - Software update available through Bluetooth or UART
 - Very large compatibility with Phones, Smart phones, PDAs, Music players
- **External Bluetooth Antenna connection diagnostic**

- **HSTI**

In order to facilitate communication between the FC6000 and your product host microprocessor, Parrot has created and provides the HSTI Library. The HSTI library is the software application programming interface (API) to integrate the FC6000 command and control within the software of the host processor.

HSTI is backward compatible with former AT commands. Few adaptations may be considered due to the improvements in the new modules generation. Application notes are available.

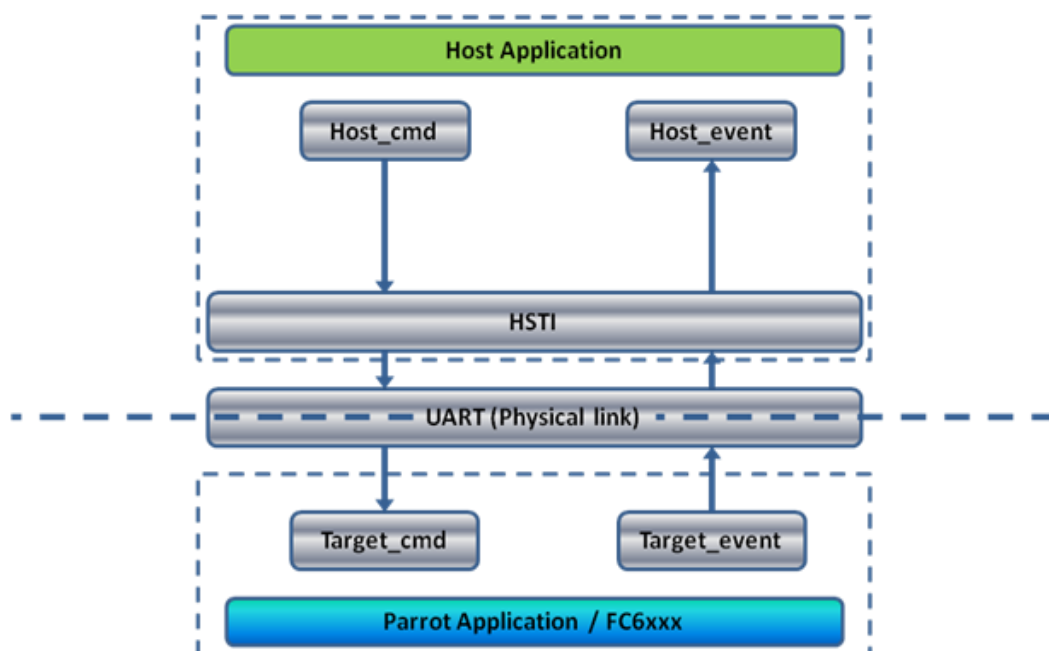

2 Software specifications

2.1 Bluetooth stack

- HCI (Host Controller interface),
- L2CAP (Logical Link Control and Adaptation Protocol),
- RFCOMM
- SDP (Service Discovery Protocol),
- OBEX (IrDA Object Exchange).
- Channel manager, AMP Manager, HCI AMP (BT 3.0 software).
- HCI Read Encryption Key Size command (BT 3.0 software).

2.2 Bluetooth profile supported

- Generic Access Profile
- Phone Management
 - HFP 0.96 / 1.0 / 1.5
 - Multi-HFP¹
 - HSP 1.0 / 1.2
 - SAP (SIM Access Profile) 1.1²
- Message Management
 - MAP 1.0 (optional)
- Phone Book
 - PBAP 1.0 / 1.1
 - SYNC 1.1 (IrMC SYNC over BT)
 - SYNCML
 - OPP Server/Client (Vcard 3.0) 1.0 / 1.1 / 1.2
 - GSM 07.07 AT Commands
 - Nokia synchronization protocol
- Multimedia
 - A2DP (Audio) 1.2
 - SBC decoding
 - (optional MP3 decoding)
 - AVDTP 1.2
 - AVRCP 1.0 / AVRCP 1.3 / AVRCP 1.4
- Others
 - SPP 1.1
 - BNEP, PAN 1.0
 - FTP 1.0 / 1.1 / 1.2
 - Image transfer over OPP³
 - DUN 1.1
 - Software update over FTP
 - Secure Simple Pairing

¹ Only For Nand Version

² Only For Nand Version

³ Only For Nand Version

2.3 Software interface

The FC6000 software interface, HSTI Library, is defined by a high level command set on top of Parrot Libraries.

This interface software is based on the HSTI commands defined by Parrot. These commands are fully documented and the software library is provided by Parrot for easy implementation in the host CPU.

Some commands are used to manage Bluetooth related functions like device pairing and connection management as well as the acoustic and speech recognition functions.

The HSTI Command List and Bluetooth AT Command Software Specification are available upon request.

The Bluetooth software stack, BLUES, supports Unicode, which allows the management of language accents and allows phonebook management in any language.

2.4 Memory configurations

FC6000	FLASH	RAM	Specification
version 1	64 Mbits	256 Mbits	<u>2500 contacts x 1 phone</u> or <u>500 contacts x 5 phones</u> or other combinations of contacts and phones so that the total is 2500 / AVRCP 1.4 . MAP not supported
version 2	1 Gbits	256 Mbits	5000 contacts (5 to 10 telephones) (*) / AVRCP 1.4 / MAP / 4 Languages SIVR-TTS
version 3	2 Gbits	256 Mbits	5000 contacts (5 to 10 telephones) (*) / AVRCP 1.4 / MAP / 9 Languages SIVR-TTS

(*) the number of contacts and telephones depends on the used BT-profiles and the number of recognizable contacts for Voice Recognition

2.5 Speaker independent Voice recognition

2.5.1 Voice Recognition principles

2.5.1.1 Description

VoCon 3200 V3.3 is NUANCE training-less speaker independent speech recognition algorithm.

- Phonemes recognition: words are recognized without previous training
- Words models for a better precision, especially for digits recognition
- Continuous voice recognition: no need for blanks between words
- New words learning (Voice tags), speaker dependent speech recognition (100 Voice tags, 2kbytes by Voice tag)
- Noise robustness and accuracy in an automotive environment: engine, click-button etc...
- Highly accurate recognition

2.5.1.2 Operation

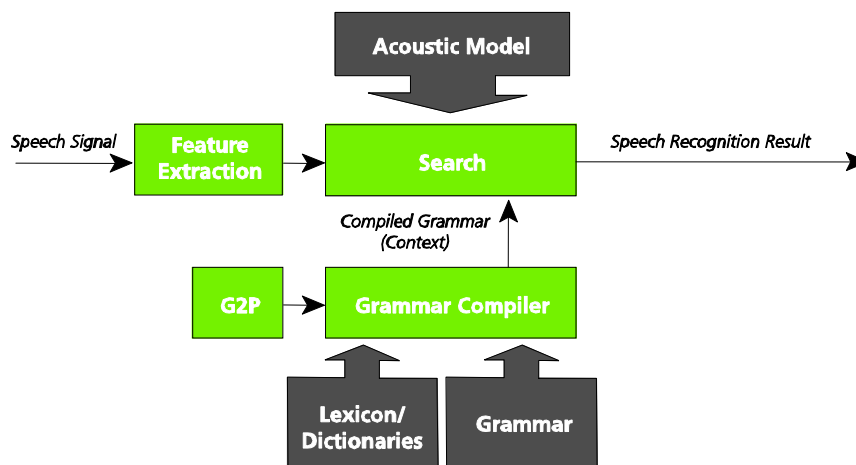

During a voice recognition process, "Feature Extraction" module decomposes the signal. The module "Search" looks for the equivalent text using the modules "G2P" and "Grammar to compile". These two modules are using the libraries "Acoustic Model", "Lexicon" and "Grammar".

Module G2P ensures equivalence between the graphemes and the phonemes.

For each language is associated an acoustic model ("Acoustic Model"), a grammar and a lexicon ("Grammar" and "Lexicon").

System feedback is realized by a screen display and/or sounds (synthesized voice, chime, pre-recorded voice prompts...).

Operation is ended by a final action (phone number dialing, radio station tuning...).



2.5.2 Text To Speech (TTS)

Text to Speech (TTS) on FC6000 is based on SVOX Automotive Speech.

SVOX Automotive TTS solutions are tailored for noisy car environments and enjoy a reputation for industry-leading quality. They power many of the most advanced and successful in-dash infotainment systems in the market. SVOX TTS technology is characterized by natural and clear sound as well as unique polyglot capability – the same voice can speak multiple languages like a native speaker.

It is not limited in vocabulary. It can be used to confirm the orders identified by a voice recognition process or for reading vehicle commands, songs titles or phonebook entries.

Please find below Voice Recognition and TTS languages available in FC6000:

01) ENU	US English	08) SPE	Spanish	14) TRT	Turkish
02) FRC	CA French	09) DUN	Dutch	15) RUR	Russian
03) SPM	Mexican Spanish	10) DAD	Danish	16) PLP	Polish
04) ENG	UK English	11) SWS	Swedish	17) CZC	Czech
05) FRF	French	12) PTP	Portuguese	18) MNC	Mandarin Chinese
06) ITI	Italian	13) PTB	Brazilian Portuguese	19) KOK	Korean
07) GED	German			20) JPN	Japanese

3 Electrical specifications

3.1 Hardware architecture

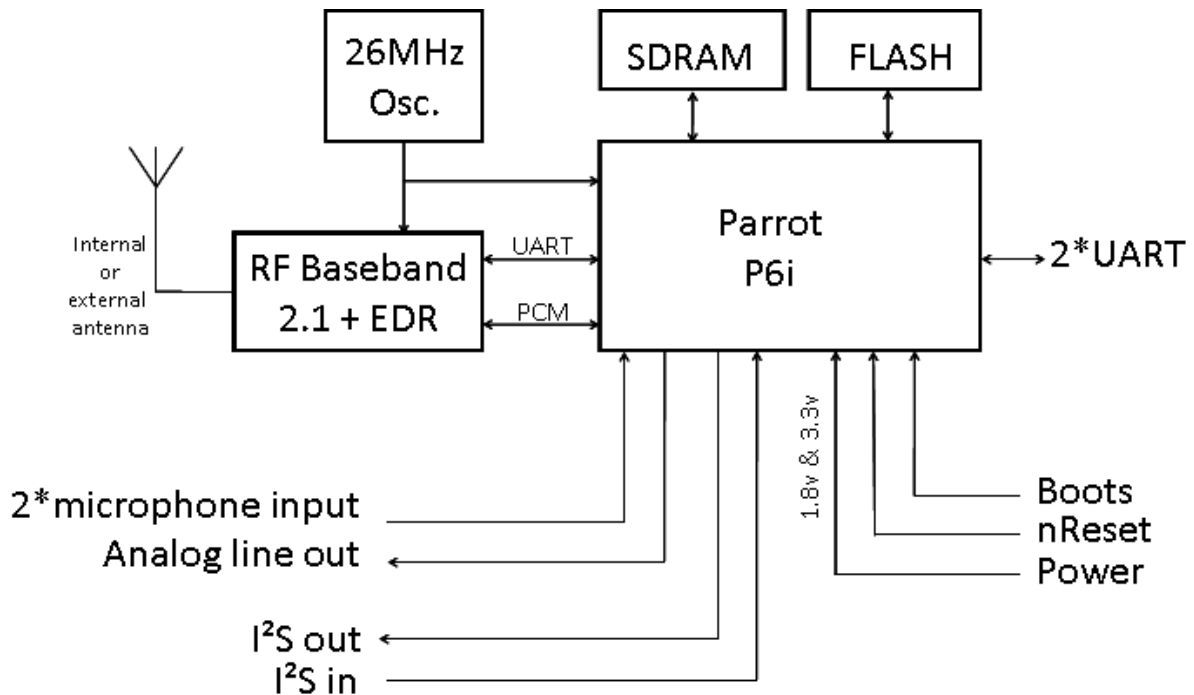

3.2 Pin-out

3.2.1 Pin-out diagram

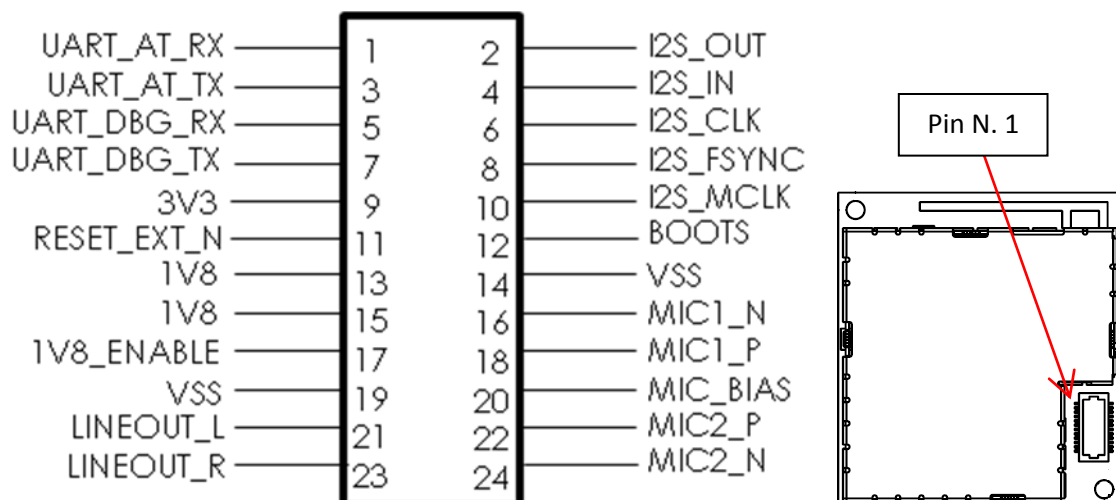

3.2.2 Pinout table

PIN	SIGNAL	PIN TYPE	FUNCTION	Voltage Rating (V)	
				Min	Max
1	UART_AT_RX	I	AT Commands & flash update UART input	-0.3	3.6
2	I2S_OUT	O	Digital audio data output	VSS	P3V3
3	UART_AT_TX	O	AT Commands & flash update UART output	VSS	P3V3
4	I2S_IN	I	Digital audio data input	-0.3	3.6
5	UART_DBG_RX	I	Debug UART input	-0.3	3.6
6	I2S_CLK	O	Digital audio main clock (Module is used to be set as master)	VSS	P3V3
7	UART_DBG_TX	O	Debug UART output	VSS	P3V3
8	I2S_FSYNC	IO	Digital audio synchronization clock (Module is used to be set as master)	-0.3	3.6
9	P3V3	P	Positive power supply : 3,3V	-0.3	3.6
10	I2S_MCLK	O	Digital audio master clock (Module is used to be set as master)	VSS	P3V3
11	RESET_EXT_N	I	Reset signal – Active Low	-0.3	3.6
12	BOOTS	I	Boot mode selection signal – Active High	-0.3	3.6
13	P1V8	P	Positive power supply : 1V8	-0.3	1.89
14	VSS	P	Power supplies ground	0	0
15	P1V8	P	Positive power supply : 1V8	-0.3	1.89
16	MIC1_N	AI	Negative differential Microphone input 1	-0.3	3.8
17	1V8_ENABLE	O	1V8 Power Supply Enable signal – Active High	VSS	P3V3
18	MIC1_P	AI	Positive differential Microphone input 1	-0.3	3.8
19	VSS	P	Power supplies ground	0	0
20	MIC_BIAS	AO	Microphones bias voltage	2.5	3.0
21	LINEOUT_L	AO	Analog audio stereo output, left channel	VSS	2.8
22	MIC2_P	AI	Positive differential Microphone input 2	-0.3	3.8
23	LINEOUT_R	AO	Analog audio stereo output, right channel	VSS	2.8
24	MIC2_N	AI	Negative differential Microphone input 2	-0.3	3.8

Legend: **I** Input **AI** Analog Input
 O Output **AO** Analog Output
 IO Input/Output **P** Power

3.2.3 Unconnected pins advice

PIN	FUNCTION	PIN TYPE	COMMENT
1	UART_AT_RX	I	N/A
2	I2S_OUT	O	Left Open
3	UART_AT_TX	O	N/A
4	I2S_IN	I	Left Open
5	UART_DBG_RX	I	Left Open (Connect to Test Point)
6	I2S_CLK	O	Left Open
7	UART_DBG_TX	O	Left Open (Connect to Test Point)
8	I2S_FSYNC	IO	Left Open
9	P3V3	P	N/A
10	I2S_MCLK	O	Left Open
11	RESET_EXT_N	I	Left Open
12	BOOTS	I	Left Open
13	P1V8	P	N/A
14	VSS	P	N/A
15	P1V8	P	N/A
16	MIC1_N	I	Left Open
17	1V8_ENABLE	O	Left Open
18	MIC1_P	I	Left Open
19	VSS	P	N/A
20	MIC_BIAS	O	Left Open
21	LINEOUT_L	O	Left Open
22	MIC2_P	I	Left Open
23	LINEOUT_R	O	Left Open
24	MIC2_N	I	Left Open

3.3 Absolute Maximum ratings

Operating temperature range	-40°C to +85°C
Storage temperature range	-40°C to +125°C
Voltage on Vcc with respect to Vss	3.1V to 3.6V
ESD sensitivity according ESD Association AEC Q100	±2kV HBM / ±200V MM

3.4 Power consumption (T°=25°C, 1V8 provided by LDO MPS2002)

3.4.1 Power consumption on 3V3 Power Supply

Stop mode (reset pin low).....	<6mA
Run mode (waiting for commands).....	<40mA
Hands free and audio streaming mode.....	<120mA
Peak current at startup	40mA

3.4.2 Power consumption on 1V8 Power Supply

Stop mode (reset pin low).....	0mA
Run mode (waiting for commands).....	<80mA
Hands free and audio streaming mode.....	<180mA
Peak current at startup	625mA

3.5 Electrical characteristics

3.5.1 Power pins

Conditions unless noted, otherwise : Tamb.=25°C					
Parameter	Conditions	Min.	Typ.	Max.	Unit
3V3 power supply		3.1	3.3	3.6	V
1V8 power supply		1.73	1.8	1.89	V

3.5.2 IO pins

3.5.2.1 Reset pin

Conditions unless noted, otherwise : T=-40°C to +85°C; Vcc=3.1 to 3.6V					
Parameter	Conditions	Min.	Typ.	Max.	Unit
Active reset voltage level		-	-	0.69	V
Non active reset voltage level		2.54	-	-	V
Active low min hold time	Vcc=3.3V, Vreset<0.69V	350	-	-	ns
Max transient short circuit not resetting the module	Vcc=3.3V, Vreset=0V	-	-	20	ns

3.5.2.2 BOOTS

Conditions unless noted, otherwise : Tamb.=25°C; Vcc=3V3					
Parameter	Conditions	Min.	Typ.	Max.	Unit
BOOTS V _{iH}		1.24	-	3.6	V
BOOTS V _{iL}		-0.3	-	0.60	V

3.5.2.3 1V8_ENABLE

Conditions unless noted, otherwise : Tamb.=25°C; Vcc=3V3

Parameter	Conditions	Min.	Typ.	Max.	Unit
1V8_ENABLE V _{OH}	I _{OH} <1mA	2.8	-		V
1V8_ENABLE V _{OL}	I _{OL} <1mA	-0.3	-	0.4	V

3.5.2.4 Recommended schematics

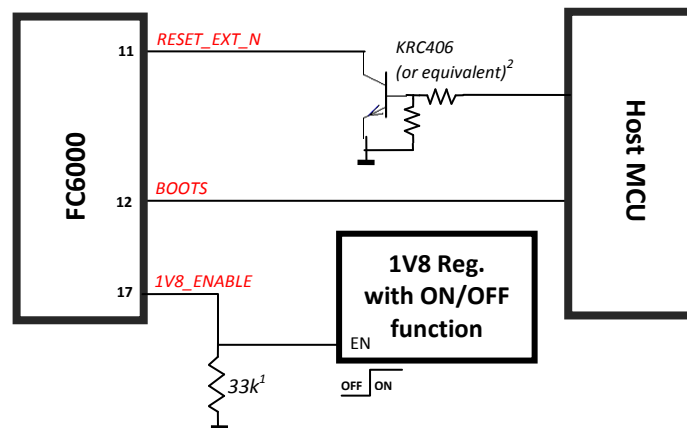

Notes:

¹: To make sure 1V8 power source is off when FC6000 is off, a Pull down resistor can be placed on 1V8_ENABLE line. Minimum value of 10kΩ is advised.

²: Because current spikes up to ~20mA can occur on RESET_EXT_N pin, it is advised to use an interface transistor to drive the RESET_EXT_N pin.

³: BOOTS can be directly driven by a MCU GPIO without special concern.

3.5.3 UART_AT/UART_DBG

Conditions unless noted, otherwise : Tamb.=25°C; Vcc=3V3

Parameter	Conditions	Min.	Typ.	Max.	Unit
Input high level voltage (V _{ih} min)		0.7*V _{cc}	-	-	V
Input low level voltage (V _{il} max)		-	-	0.3*V _{cc}	V
Output high level voltage (V _{oh} min)	I _{oh} <1mA	V _{cc} -0.5	-	-	V
Output low level voltage (V _{ol} max)	I _{ol} <1mA	-	-	0.4	V
Rise time	C _{load} =20pf	-	-	170	ns
Fall time	C _{load} =20pf	-	-	160	ns
Difference between rise and fall time	C _{load} =20pf			20	ns
Baud rate		-	115.2	-	kbps
Emission Baud rate precision		-	0.25	-	%
Reception Baud rate tolerance		-	2.5	-	%

3.5.3.1 Recommended schematics

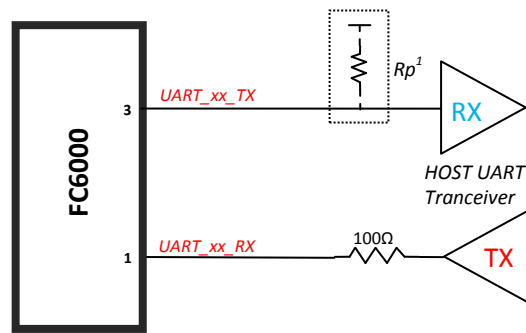

Notes:

¹: FC6000 module would have internal Pull resistors on UART lines once booted (AT command *PSTU has been released).

In case idle level is required by host FW on UART lines while FC6000 is in Reset mode, an external pull resistor R_p should be added to the proper level on the host side.

²: FC6000 UART is 16C550 interface type

3.5.4 I2S IO

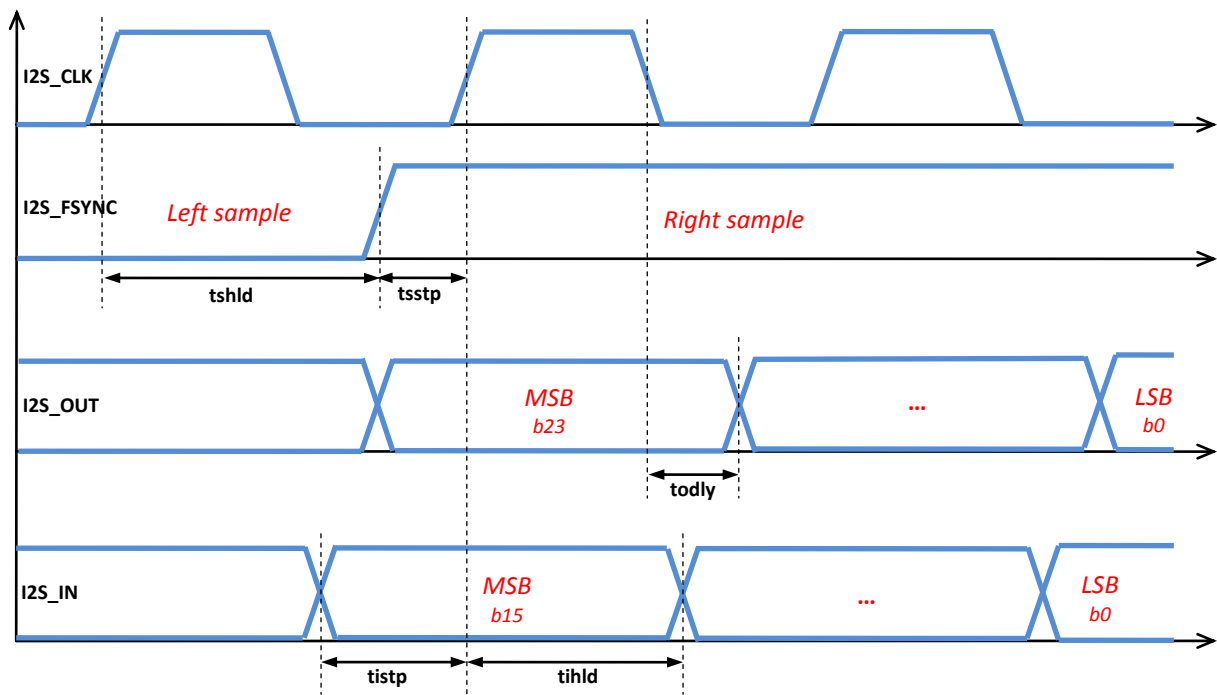

Conditions unless noted, otherwise : $T_{amb.}=25^{\circ}C$; $V_{cc}=3V3$

Parameter	Conditions	Min.	Typ.	Max.	Unit
Input high level voltage (V_{ih} min)		$0.7 \cdot V_{cc}$	-	-	V
Input low level voltage (V_{il} max)		-	-	$0.3 \cdot V_{cc}$	V
Output high level voltage (V_{oh} min)		$V_{cc}-0.5$	-	-	V
Output low level voltage (V_{ol} max)		-	-	0.4	V
Sampling Frequency (F_s)		-	44.1 / 48	-	kHz
Bit Clock Frequency (F_{clk})		-	$64 \cdot F_s$	-	kHz
Rise time	Clod=20pf	-	-	5	ns
Fall time	Clod=20pf	-	-	5	ns



SYNC_CLK hold time (tshld)		10	-	-	ns
SYNC_CLK setup time (tsstp)		10	-	-	ns
I2S_OUT propagation delay (todly)		-	-	10	ns
I2S_IN setup time (tistp)		10	-	-	ns
I2S_IN hold time (tihld)		10	-	-	ns

3.5.4.1 Recommended schematics

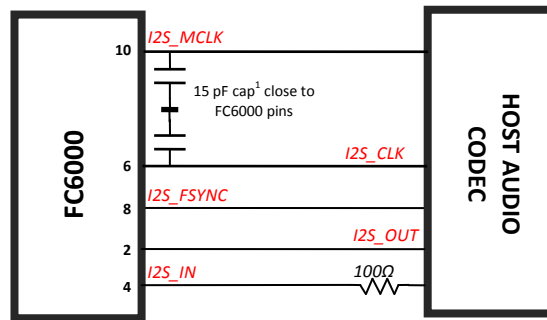

Notes:

- ¹: 15pF bypass capacitors might be used on fastest clocks to improve EMC performances.
- ²: I²S interface is defaulted to Texas Transmit Mode.

3.5.5 Audio

3.5.5.1 Analog out

Conditions unless noted, otherwise : Tamb.=25°C; Vcc=3V3 (I2S in -> audio out)

Parameter	Conditions	Min.	Typ.	Max.	Unit
Drive load capability	Lineout to agnd, AC coupled	7	-	-	kΩ
		-	30	1000	pF
Maximum output level	Next stage input impedance = 100k	-	-	0.85	Vrms
Output impedance	Z _L ≥ 7kohm	150	-	250	Ω
High cut-off frequency	-	-	=0.4535xFs	-	Hz
Signal to Noise Ratio	@ 1kHz, 0.75Vrms	80	-	-	dB
THD+N	@ 1kHz, 0.75Vrms	-	0.02	0.1	%
Crosstalk between channels	@ 1kHz, 1.25 Vrms	-	-	-91	dB
	@ 10kHz, 1.25 Vrms	-	-	-80	dB

3.5.5.1.1 Recommended schematics

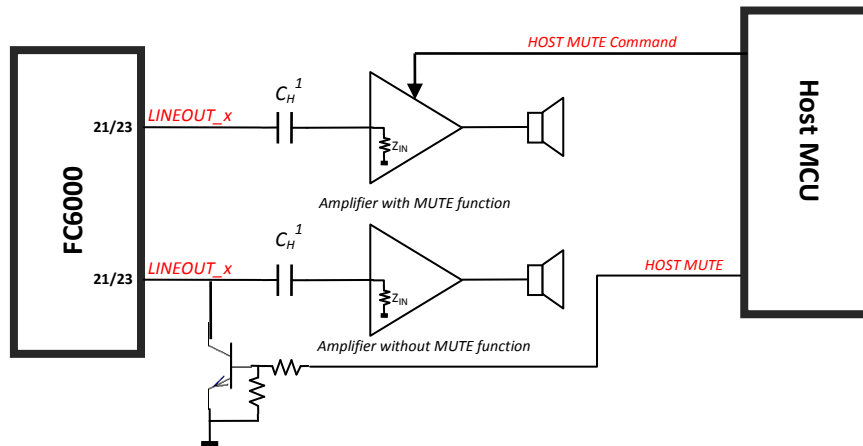

Notes:

1: $\frac{1}{2 \cdot \pi \cdot C_H \cdot Z_{IN}} \approx 10\text{Hz}$ for music output, 200Hz for voice only output. $Z_{in} > 7\text{k}\Omega$

2: A mute function shall be provided by the host, to prevent 'plop' sounds when FC6000 is powered up/down.

3.5.5.2 Microphone input

Conditions unless noted, otherwise : Tamb.=25°C; Vcc=3V3 (voice in ->I2S out)					
Parameter	Conditions	Min.	Typ.	Max.	Unit
Input impedance	+30dB gain	7.1	-	-	kΩ
Linear Dynamic Range	0dB gain	73	-	-	dB
Maximum input signal	0dB gain	840	-	890	mVrms
Low Cut-off Frequency	100nF capacitor on mother board	-	20	250	Hz
High Cut-off Frequency	-	-	3450	-	Hz
Signal to Noise Ratio	@1kHz, 0.76Vrms	80	86	89	dB
THD+N	@1kHz, 0.76Vrms	-	0.0054	0.1	%
Crosstalk between channels	@ 1kHz, 1Vrms	-	-	-90	dB

3.5.5.2.1 Recommended schematics

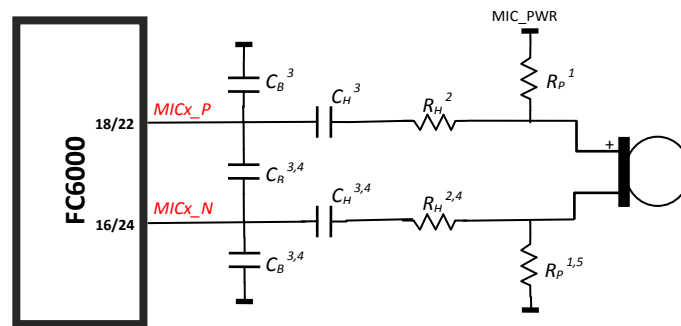

Notes:

¹: For R_P value, please look up your microphone datasheet

²: R_H value comprises microphone's output impedance plus an eventual serial resistor.

For best response with voice input, please make sure that:

$$150\Omega \leq R_H \leq 680\Omega$$

to insure:

$$0.4\text{dB} \leq \text{Filter loss} \leq 1\text{dB}$$

into the voice frequency range [0.3kHz ; 4kHz].

³: We recommended using $C_B=10\text{nF}$, and $C_H=560\text{nF}$ for best voice frequency response [0.3kHz ; 4kHz].

⁴: When using single ended design, do not mount

⁵: When using single ended design, replace by short.

3.5.5.3 Microphone bias

Conditions unless noted, otherwise : Tamb.=25°C; Vcc=3V3						
Parameter	Conditions	Min.	Typ.	Max.	Unit	
Bias voltage	Vdd_codec = 3V, Ibias < 3mA	2.5	-	3	V	
Max load current		-	-	3	mA	
Coupling between channels	MIC_PWR=MIC_BIAS 470 μF filtering capacitor, Rbias = 1kΩ	@200Hz, 1Vrms	-	-	-52	dB
		@1kHz, 1Vrms	-	-	-61	

3.5.5.3.1 Recommended schematics

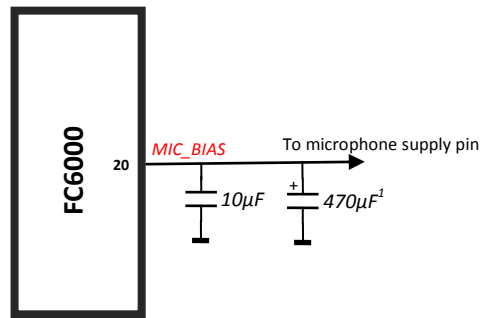

Note:

¹: When using the same microphone bias source for both microphones, it is strongly recommended to add a high value-low ESR filtering capacitor on the bias source to prevent coupling between the 2 channels.

3.5.6 Bluetooth radio link

Conditions unless noted, otherwise : Tamb.=25°C; Vcc=3V3					
Parameter	Conditions	Min.	Typ.	Max.	Unit
Antenna AC impedance	Module with connector only	-	50	-	Ω
Antenna DC impedance	Module with connector only	0	-	3.4	kΩ

3.6 Reset and supply sequence diagram

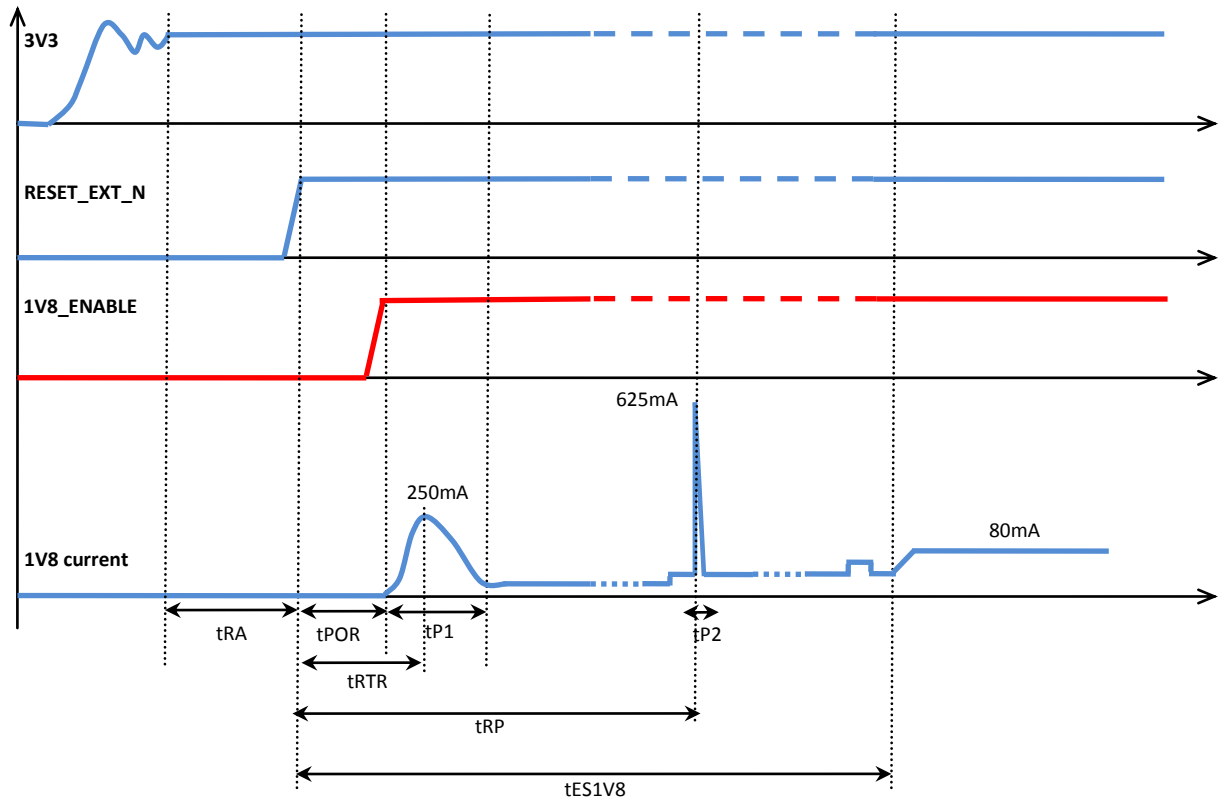

Conditions unless noted, otherwise : Tamb.=25°C; Vcc=3V3					
Parameter	Conditions	Min.	Typ.	Max.	Unit
tRA		102	-	-	ms
tPOR		-	30.5	-	µs
tRTR		-	100	-	µs
tP1		-	-	200	µs
tRP		-	6.9	-	ms
tP2		-	-	8	µs
tES1V8		-	-	20	ms

3.7 Flash update sequence diagram

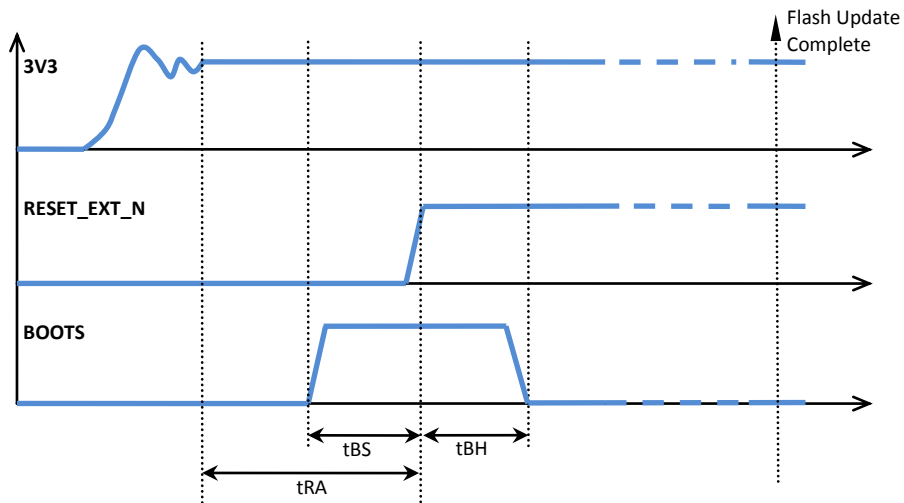

Conditions unless noted, otherwise : Tamb.=25°C; Vcc=3V3					
Parameter	Conditions	Min.	Typ.	Max.	Unit
tBS		30	-	-	µs
tBH		30	-	-	µs

3.8 Power Off Sequence diagram

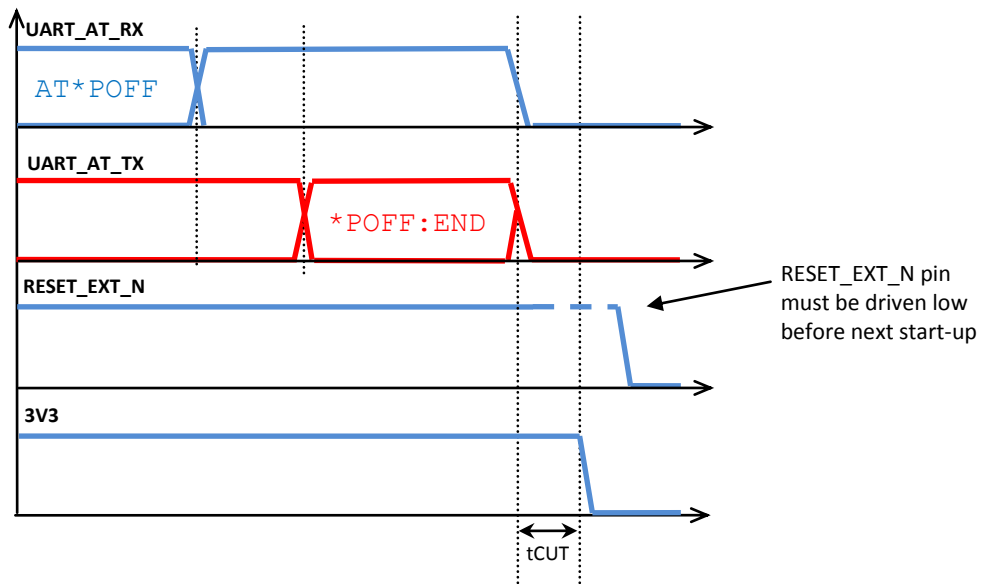

Conditions unless noted, otherwise : Tamb.=25°C; Vcc=3V3					
Parameter	Conditions	Min.	Typ.	Max.	Unit
tCut		0	10	-	µs

3.8.1 Power supplies reference design

3.8.1.1 3V3

3V3

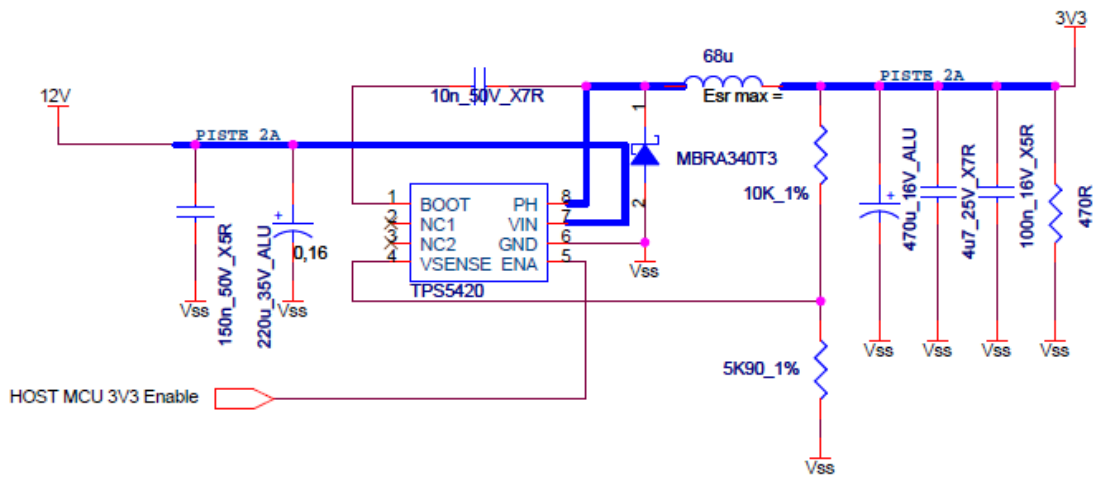

3.8.1.2 1V8

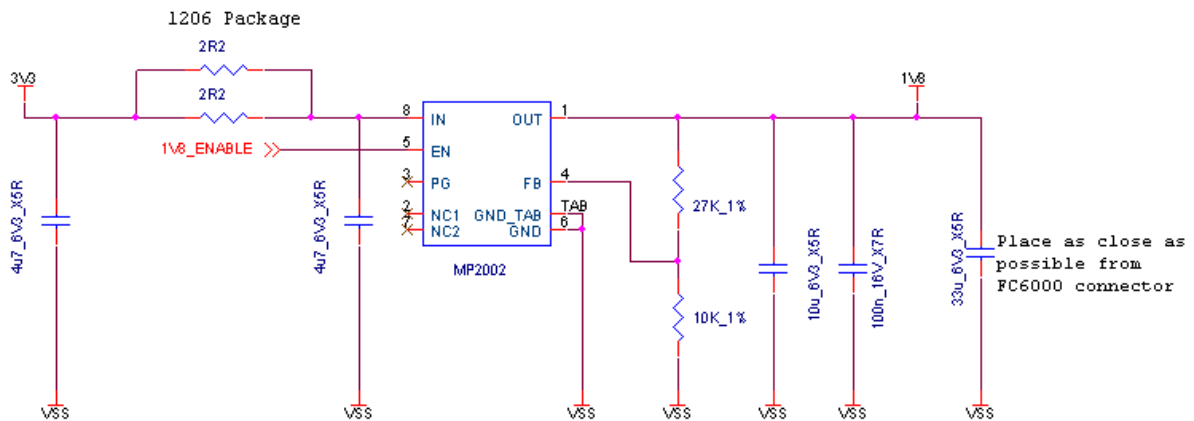

4 Mechanical specifications

The following chart describes the availability of the various versions of the FC6000.

Module version	Mounting	Bluetooth antenna	
		Internal	external
FC6000	horizontal	Yes	Yes
	vertical	Yes	Yes

4.1 Horizontal module with external antenna

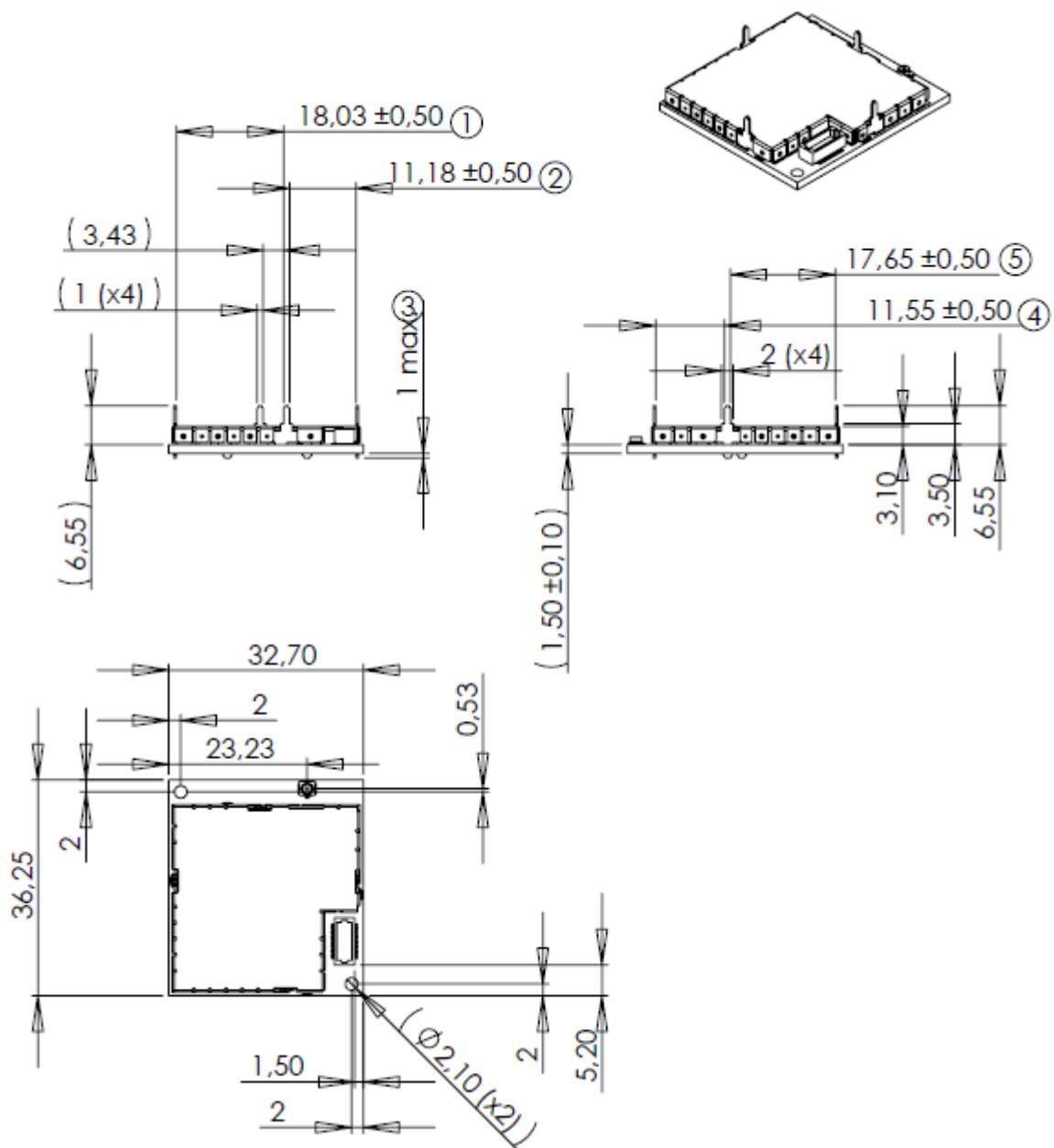



4.2 Horizontal module with internal antenna

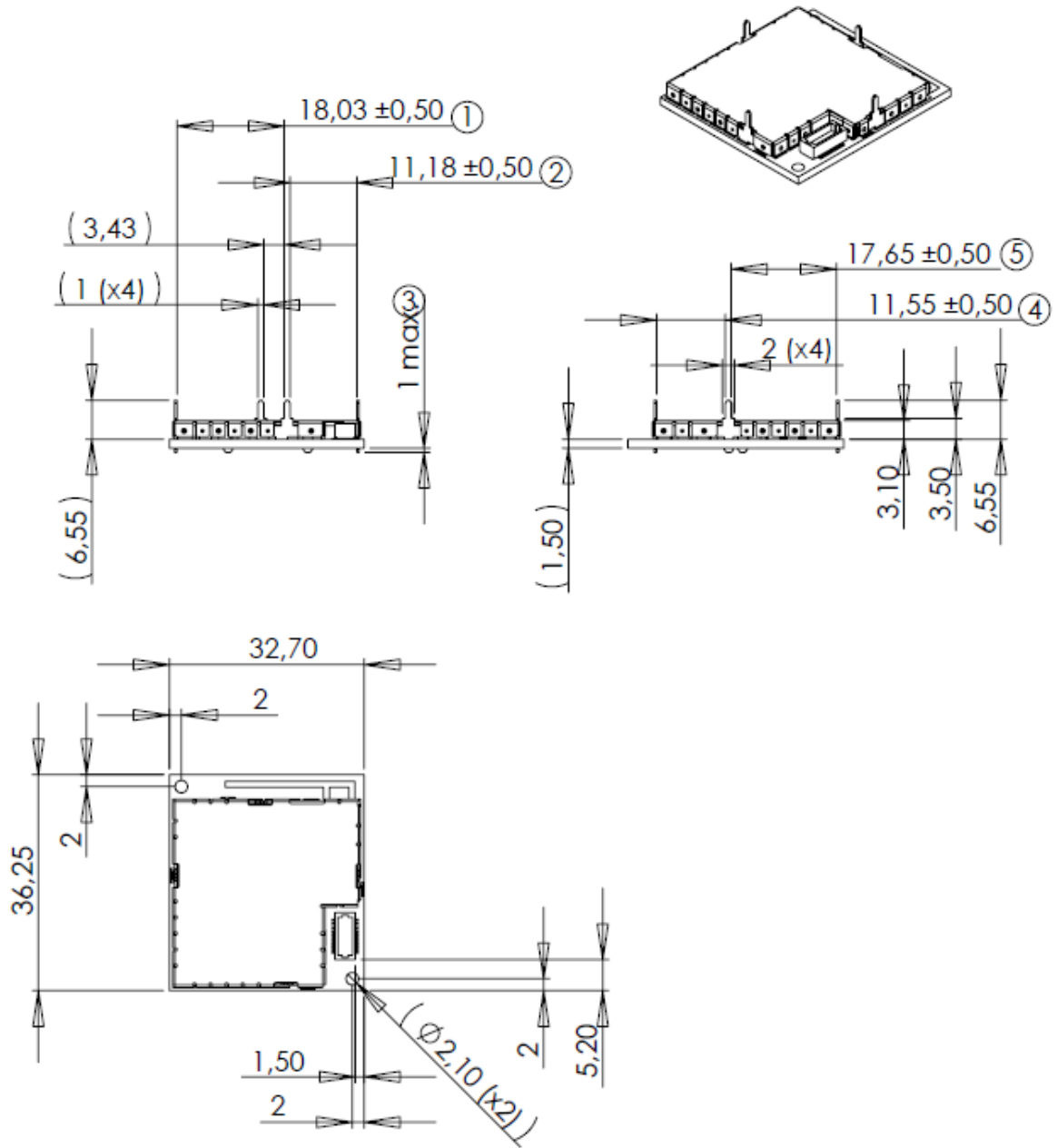

4.3 Vertical module with external antenna

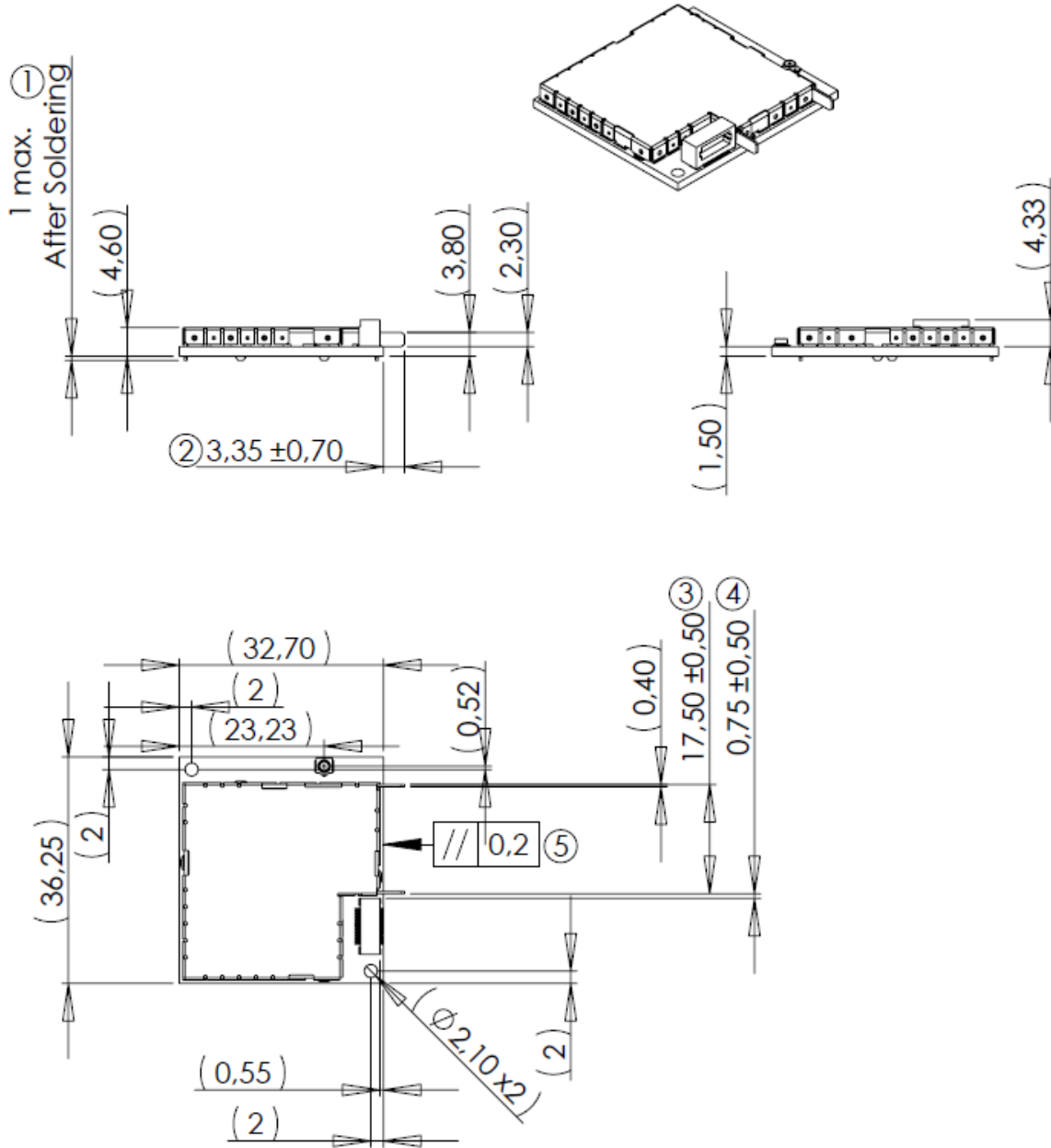

4.4 Vertical module with internal antenna

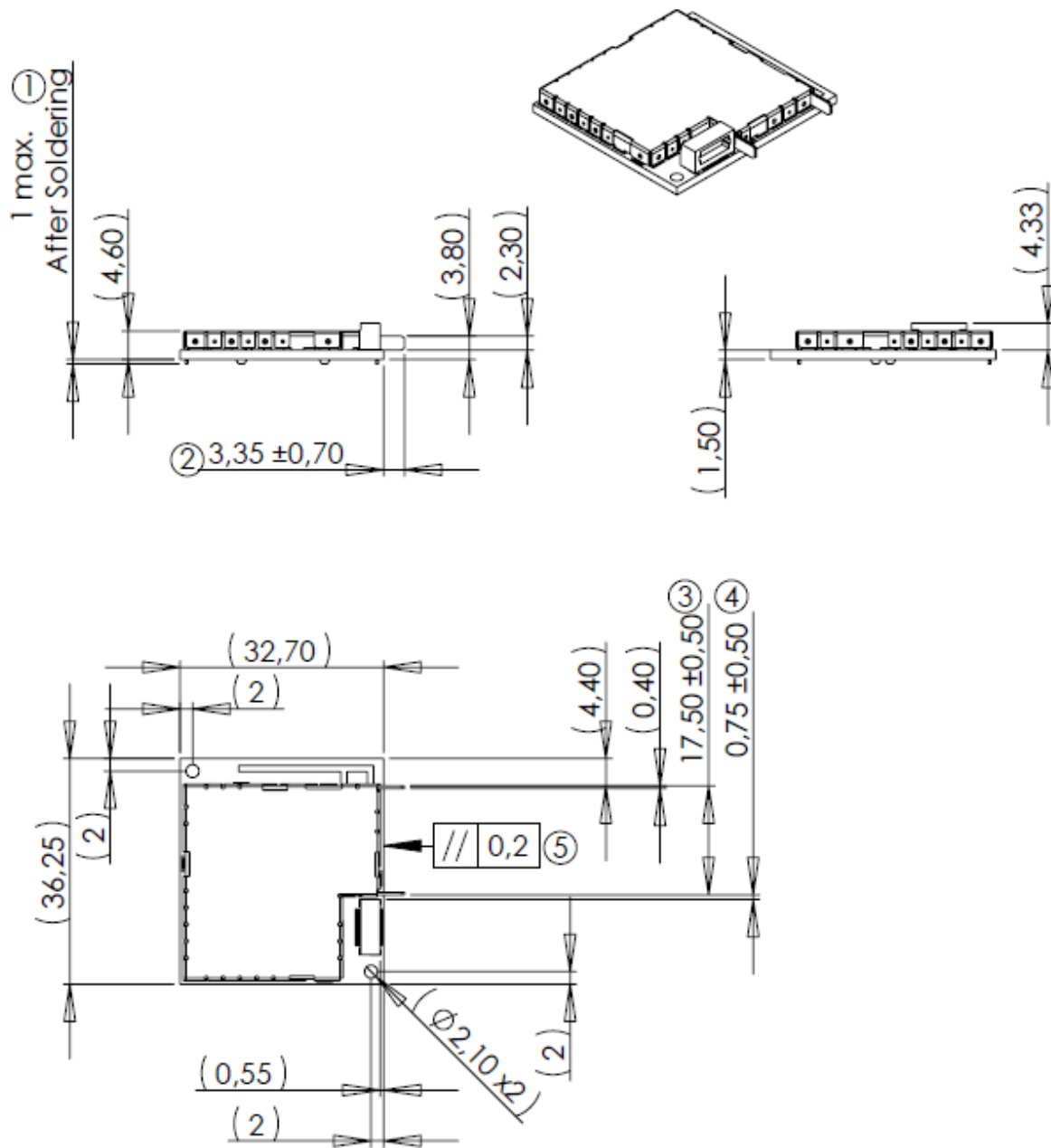

4.5 Module connectors

4.5.1 Connector on mother board

JST reference: 24R-JMCS-G-(B)-TF

Mechanical overview:

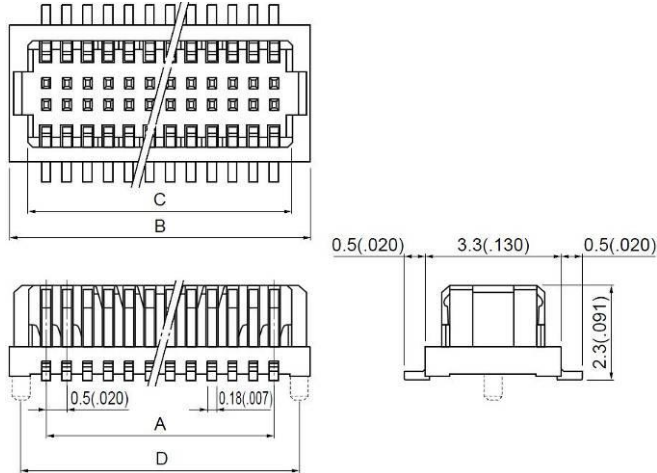

Recommended PCB footprint:

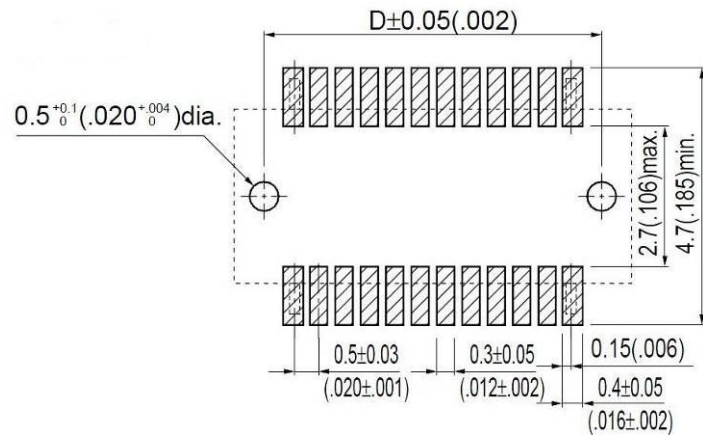

Cir- cuits	Model No.		Dimensions mm(in.)				Q'ty / reel
	Without bosses	With bosses	A	B	C	D	
24	24R-JMCS-G-TF (S)	24R-JMCS-G-B-TF (S)	5.5(.217)	7.3(.287)	6.4(.252)	6.7(.264)	2,500

4.5.2 Horizontal modules connector

JST reference: 24P3.5-JMCS-G-TF (Top entry type)

Mechanical overview:

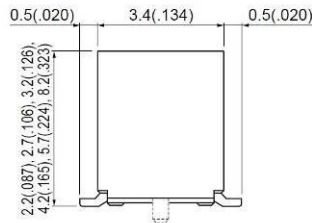
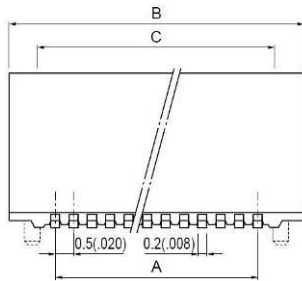
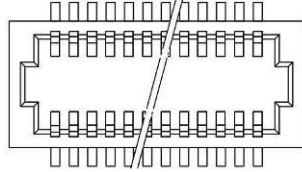

Recommended PCB footprint:

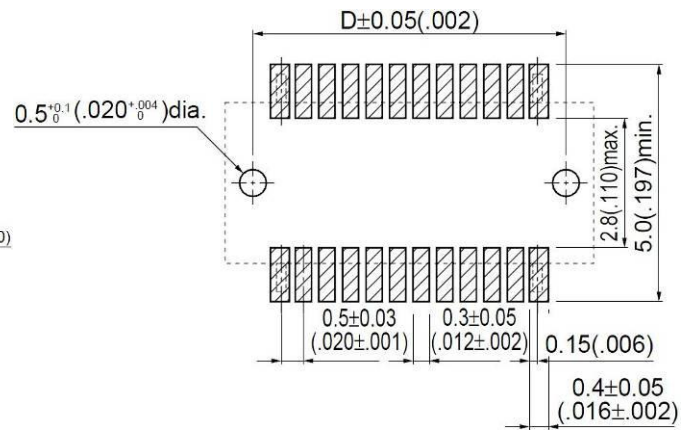

Circuits	Model No.				Dimensions (mm)			
	Stacking height (mm)				A	B	C	D
24	3.0	3.5	4.0	4.5	5.5	7.9	6.4	—
	—	24P3.5-JMCS-G-TF	—	—				

4.5.3 Vertical modules connector

JST reference: 24PS-JMCS-G-1B-TF (Side entry type)

Mechanical overview:

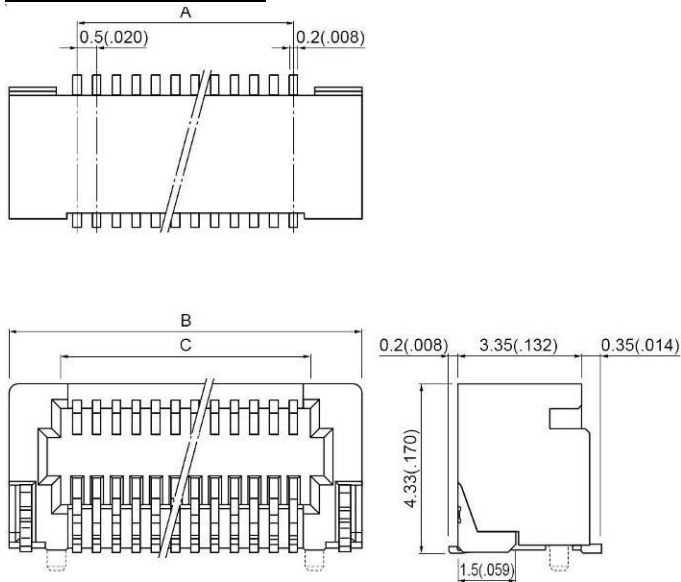

Recommended PCB footprint:

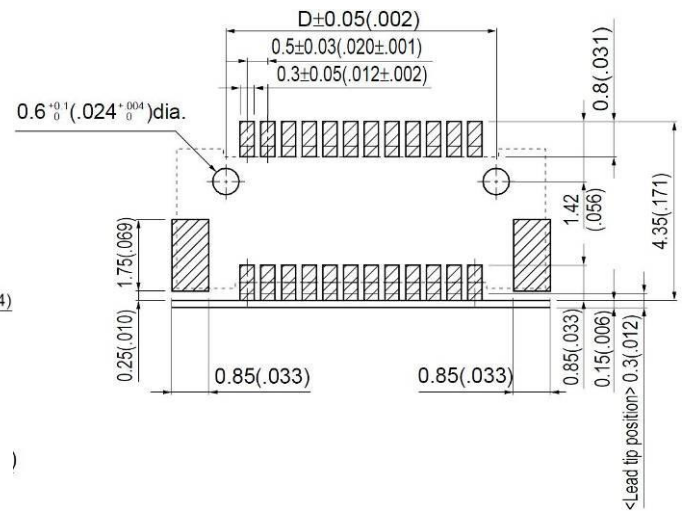

Circuits	Model No.	Dimensions (mm)				Q'ty / reel
		A	B	C	D	
24	24PS-JMCS-G-1B-TF	5.5	8.9	6.4	6.55	1,500

4.5.4 Antenna connector

JST reference: AYU1-1P-02676-120

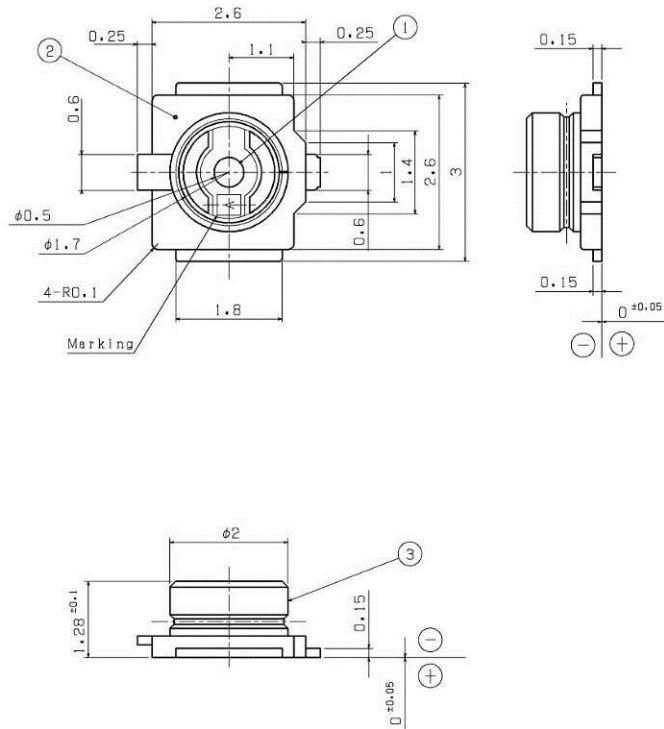

4.6 Motherboard Mechanical Integration

Mechanical constraints for the integration on the mother board are detailed below.

4.6.1 Mechanical integration – Horizontal version:

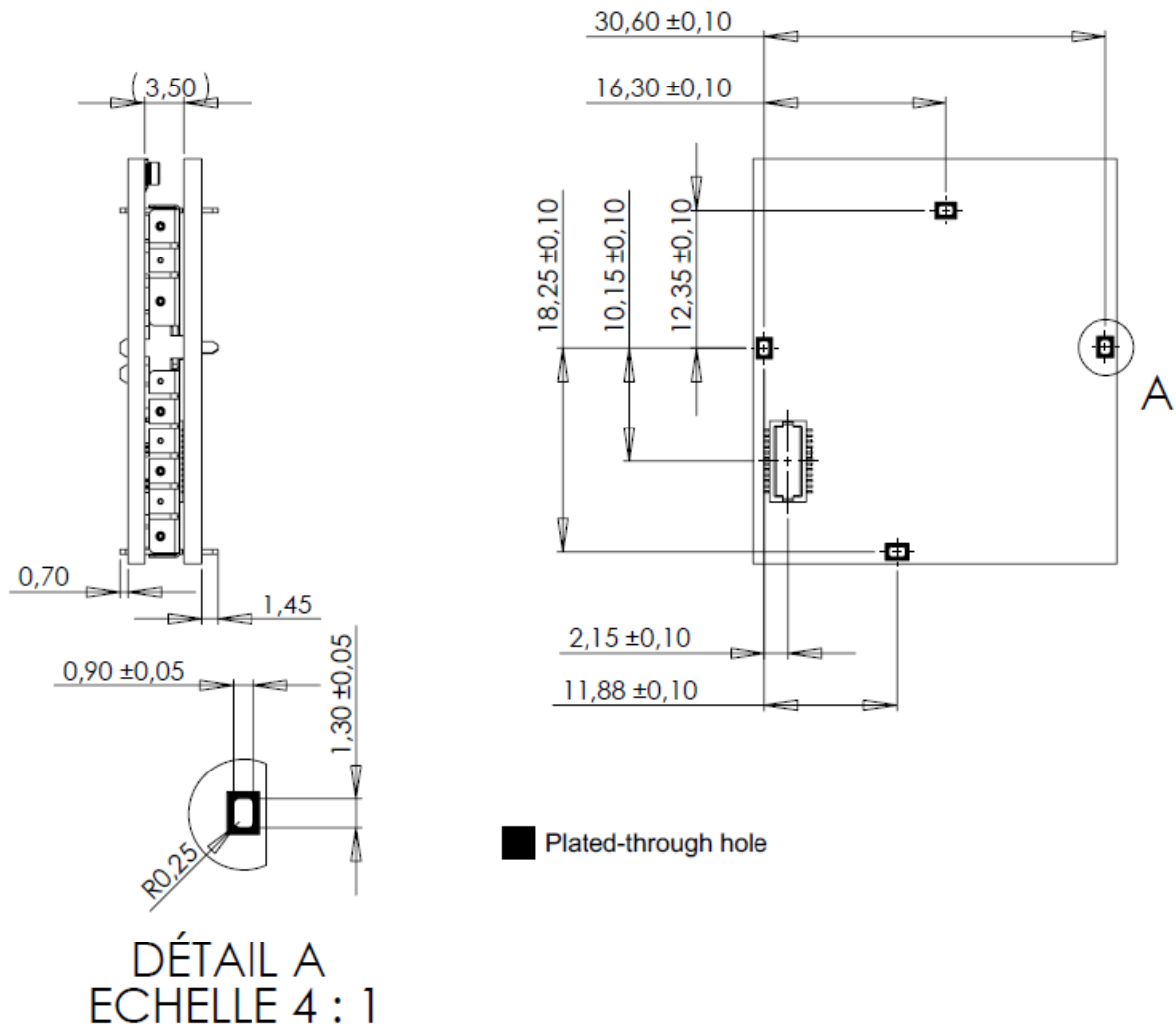

4.6.2 Mechanical integration – Vertical version:

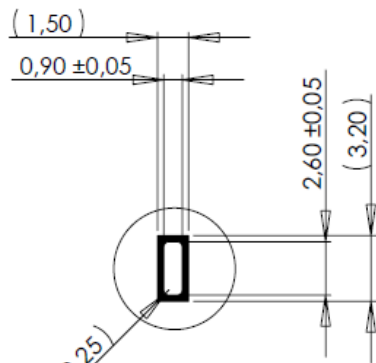
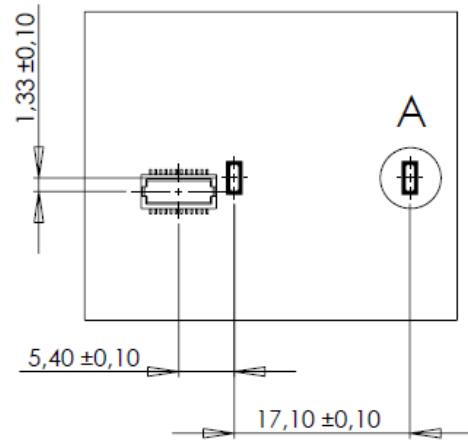
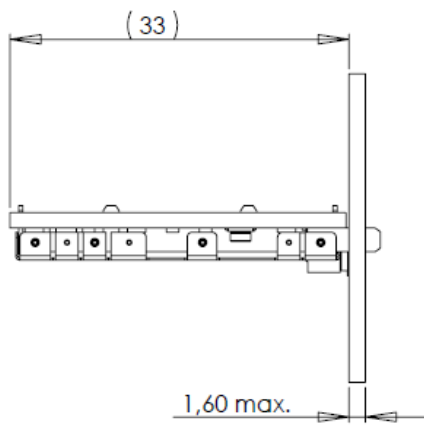

■ Plated-through hole

DÉTAIL A
ECHELLE 4 : 1

5 Available tools

5.1 Workbench

5.1.1 Diagram

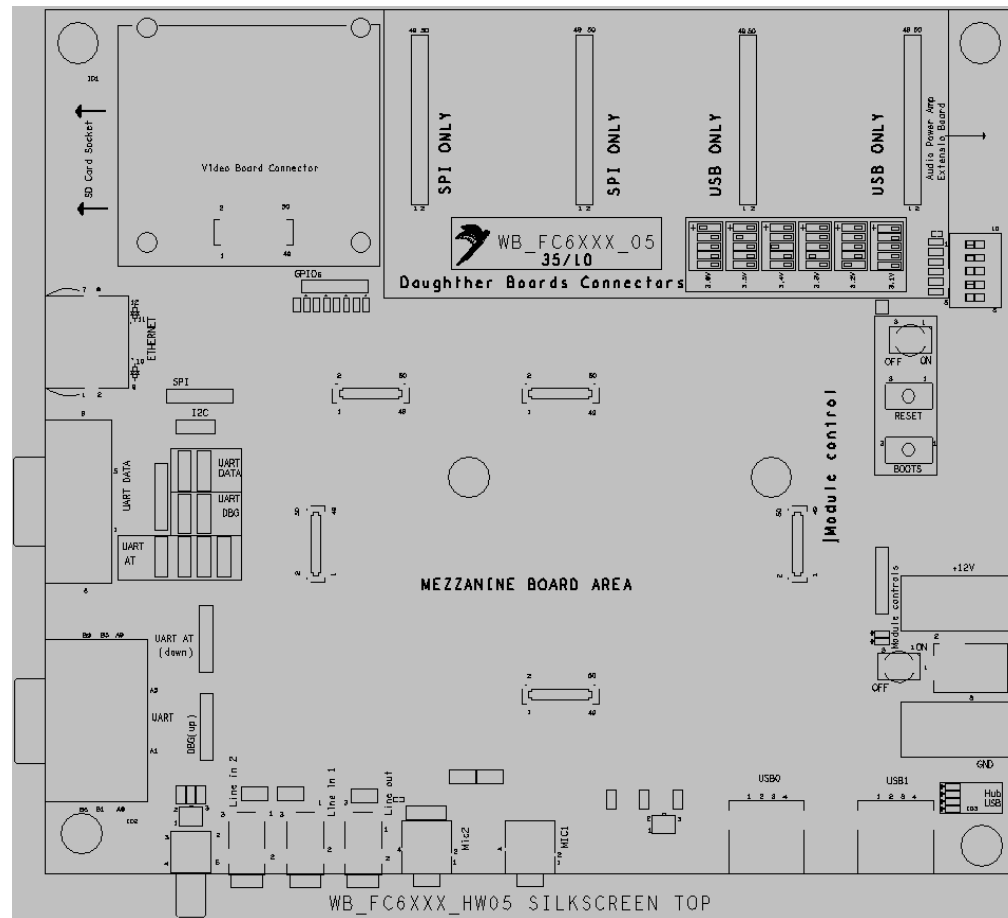



Parrot

5.1.2 Schematics

The workbench schematic will be provided on demand

5.2 WxHipHop

WxHipHop is a windows based software that gives the possibility to send and read the AT commands used by the FC6000.

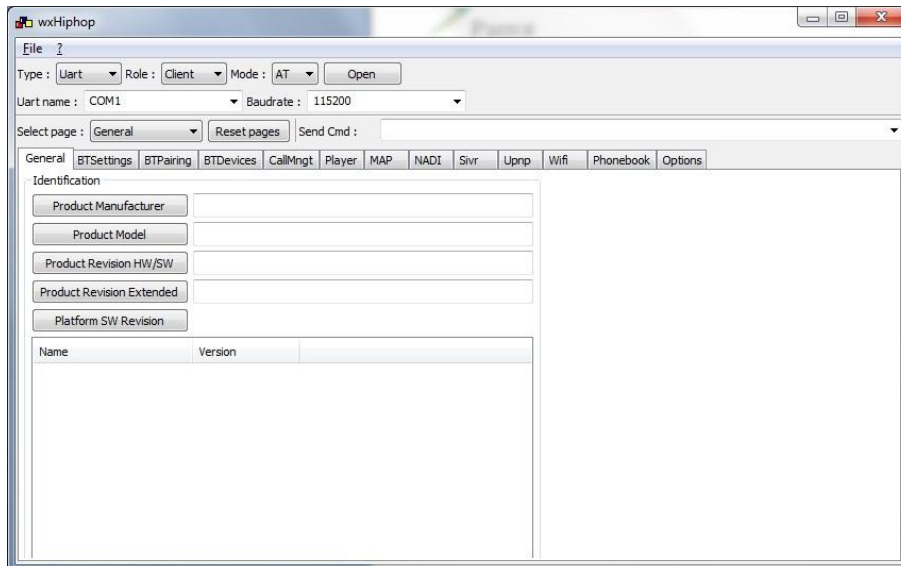

5.3 WxFlasher

WxFlasher is a windows based software that gives the possibility to flash and to update the software of the FC6000.

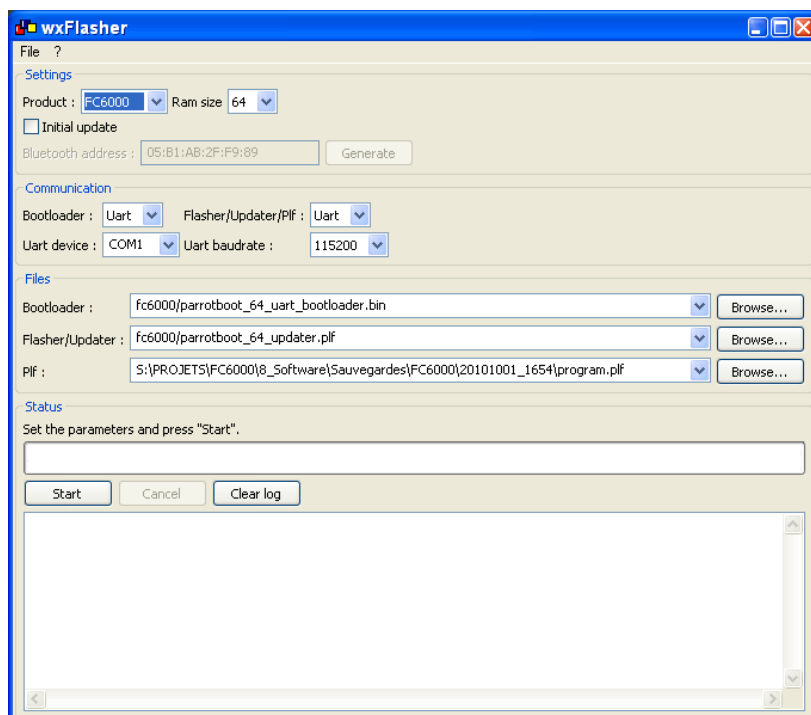

6 Approval / Certifications

6.1 FC6000S

6.1.1 CE Declaration

We, Parrot SA 174 quai de Jemmapes 75010 Paris France, declare under our responsibility that our product (Parrot FC6000S) is in conformity with the Radio and Telecommunication Equipment directive 1999/5/EC R&TTE according to the essentials requirements and respect the standard listed below :

3.1-a) Electrical Safety	EN60950-1:2006/A11:2009
EMF	EN50371 (06/2002)
3.1-b) EMC	EN301 489-1 V1.8.1
3.2 Radio	EN300 328 V1.7.1

Paris May 27th, 2011

Qualification Manager
Arezki Guerrab



6.1.2 FCC and IC requirements for module application

FCC ID: RKXFC6000S

IC : 5119A-FC6000S

In accordance with FCC Part 15, the FC6000S is listed as a Modular Transmitter device.

USA – User information

This intends to inform how to specify the FCC ID of our module “FC6000S” on the product. Based on the Public Notice from FCC, the host device should have a label which indicates that it contains our module. The label should use wording such as: “Contains FCC ID: RKXFC6000S”

Any similar wording that expresses the same meaning may be used.

The label of the host device should also include the below FCC Statement. When it is not possible, this information should be included in the User Manual of the host device.

“This device complies with part 15 of the FCC rules. Operation is subject to the following two conditions.

- (1) This device may not cause harmful interference
- (2) this device must accept any interference received, including interference that may cause undesired operation.

Caution: Changes or modifications not expressly approved by the party responsible for compliance could void the user’s authority to operate the equipment.

Canada – User information

This intends to inform how to specify the IC ID of our module “FC6000S” on the product. According to Canadian standards “RSS 210” and “RSS Gen” , the host device should have a label which indicates that it contains our module. The label should use wording such as: “Contains IC ID: 5119A-FC6000S

Any similar wording that expresses the same meaning may be used.

The label of the host device should also include the below IC Statement.

When it is not possible, this information should be included in the User Manual of the host device.

“Operation is subject to the following two conditions:

- (1) this device may not cause interference, and
- (2) this device must accept any interference, including interference that may cause undesired operation of the device.”

6.2 FC6000N

6.2.1 CE Declaration

We, Parrot SA 174 quai de Jemmapes 75010 Paris France, declare under our responsibility that our product (Parrot FC6000N) is in conformity with the Radio and Telecommunication Equipment directive 1999/5/EC R&TTE according to the essentials requirements and respect the standard listed below :

3.1-a) Electrical Safety	EN60950-1:2006/A11:2009
EMF	EN50371 (06/2002)
3.1-b) EMC	EN301 489-1 V1.8.1
3.2 Radio	EN300 328 V1.7.1

Paris May 27th, 2011

Qualification Manager
Arezki Guerrab



6.2.2 FCC and IC requirements for module application

FCC ID: RKXFC6000N

IC : 5119A-FC6000N

In accordance with FCC Part 15, the FC6000N is listed as a limited Modular Transmitter device.

USA – User information

This intends to inform how to specify the FCC ID of our module “FC6000N” on the product. Based on the Public Notice from FCC, the host device should have a label which indicates that it contains our module. The label should use wording such as: “Contains FCC ID: RKXFC6000N”

Any similar wording that expresses the same meaning may be used.

The label of the host device should also include the below FCC Statement. When it is not possible, this information should be included in the User Manual of the host device.

“This device complies with part 15 of the FCC rules. Operation is subject to the following two conditions.

- (1) This device may not cause harmful interference
- (2) this device must accept any interference received, including interference that may cause undesired operation.

Caution: Changes or modifications not expressly approved by the party responsible for compliance could void the user’s authority to operate the equipment.

Canada – User information

This intends to inform how to specify the IC ID of our module “FC6000N” on the product. According to Canadian standards “RSS 210” and “RSS Gen” , the host device should have a label which indicates that it contains our module. The label should use wording such as: “Contains IC ID: 519A-FC6000N

Any similar wording that expresses the same meaning may be used.

The label of the host device should also include the below IC Statement.

When it is not possible, this information should be included in the User Manual of the host device.

“Operation is subject to the following two conditions:

- (1) this device may not cause interference, and
- (2) this device must accept any interference, including interference that may cause undesired operation of the device.”

Le présent appareil est conforme aux CNR d'Industrie Canada applicables aux appareils radio exempts de licence. L'exploitation est autorisée aux deux conditions suivantes :

- (1) l'appareil ne doit pas produire de brouillage, et
- (2) l'utilisateur de l'appareil doit accepter tout brouillage radioélectrique subi, même si le brouillage est susceptible d'en compromettre le fonctionnement.

7 Use Cases

A. Bluetooth HFP & A2DP/AVRCP use cases overview:

a. Head Unit paired with Mobile phone

Handsfree telephony & Phonebook Synchronization

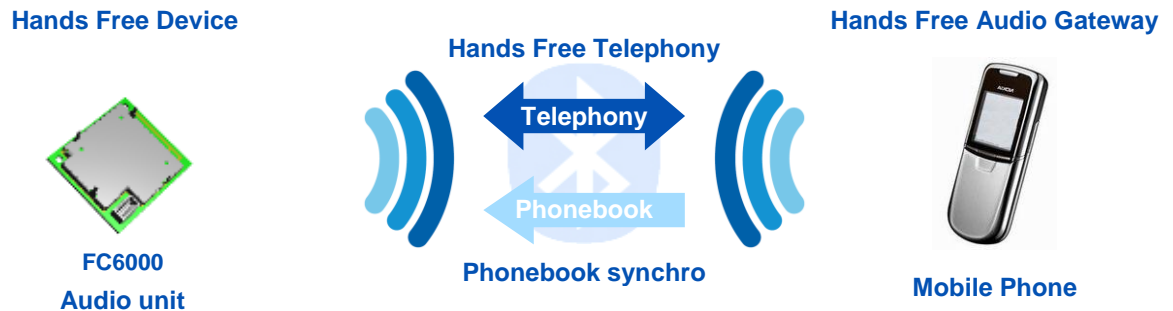

Connections Strategy

If the Host does not store the last synchronized phonebook, it is always available for the Host at Module start up. Right after HFP connection (which is initiated to the last connected device), it is possible to place an outgoing call if requested. Once HFP initialization has finished (end of SLC/Extended SLC), the Module starts the best phonebook synchronization method available on the phone. The Module alerts the Host that the updated phonebook with new entries is available, and ready to be displayed on the HMI.

If an incoming/outgoing call occurs during the phonebook synchronization process, depending on the method of phonebook synchronization which is used, the process is paused. Once the call is finished, the phonebook synchronization restarts from where it has been stopped, and the call history is updated. This is transparent for the end user.

Calls Management

For incoming calls, the Caller ID (received from phone via CLIP or CLCC) is sent to the Host to be displayed on the HMI.

HFP indicators such as signal level, battery level and network provider are forwarded to the Host to be displayed on the HMI. CIND/CIEV indicators or GSM AT Commands are used for this purpose.

Service Continuity

This feature handles the audio management of a call when the module is powered on/off:

- When the module is powered on, the module automatically connects HFP to the phone and establishes the communication ((e)SCO connection) through the speakers during the SLC.
- When the module is powered off, the module transfers the audio to the phone ((e)SCO disconnection) and disconnects the Bluetooth link.

This process ensures the Host to be immediately ready to start Handsfree usage.

Three way calling / multiple calls management

Once a call is established, if a second incoming call occurs, here is how the Host should handle the HMI:

- Green button: takes the second incoming call as active, and put the first one on hold. Press green button again to switch between the two calls.
- Red button: hangs up the active call and takes the second one as active.

Full 3-way calling management (and multiparty calls) is optimized with phones supporting HFP1.5. Parrot supports up to 7 calls at the same time for conference calls purpose.

With phones supporting HFP1.0 only, there are gaps in the specification such as:

- When the user manages the calls from the phone interface, the phone does not always notify the Module.
- When the distant party who is on hold hangs up from its side.

b. Head Unit connected to Mobile phone and headset device



SCO forwarding feature (2 SCO)

The module is connected to a Headset and a phone at the same time. When requested by the user, the Module is able to forward audio from the phone to the Headset. Therefore, the communication is switched for privacy purpose. Two SCO channels are opened from the Module.

Description of the behavior:

- *Incoming call:*
 - o Pick up from the HMI will pick up the call and establish one (e)SCO with the phone and one with the Headset.
 - o Hang up from the HMI will hang up the call and release the 2nd SCO.
- *Outgoing call:*
 - o Dialing from the HMI will place the call on the phone, and once the remote party has picked up, one (e)SCO is established with the phone and one with the Headset.
 - o Hang up from the HMI will hang up the call and release the 2nd SCO.

A command is proposed on Parrot Module to handle the establishment of dual SCO, depending on user need.

c. Head Unit paired with two Mobile phones

Establish and receiving call possible on two different mobile phones

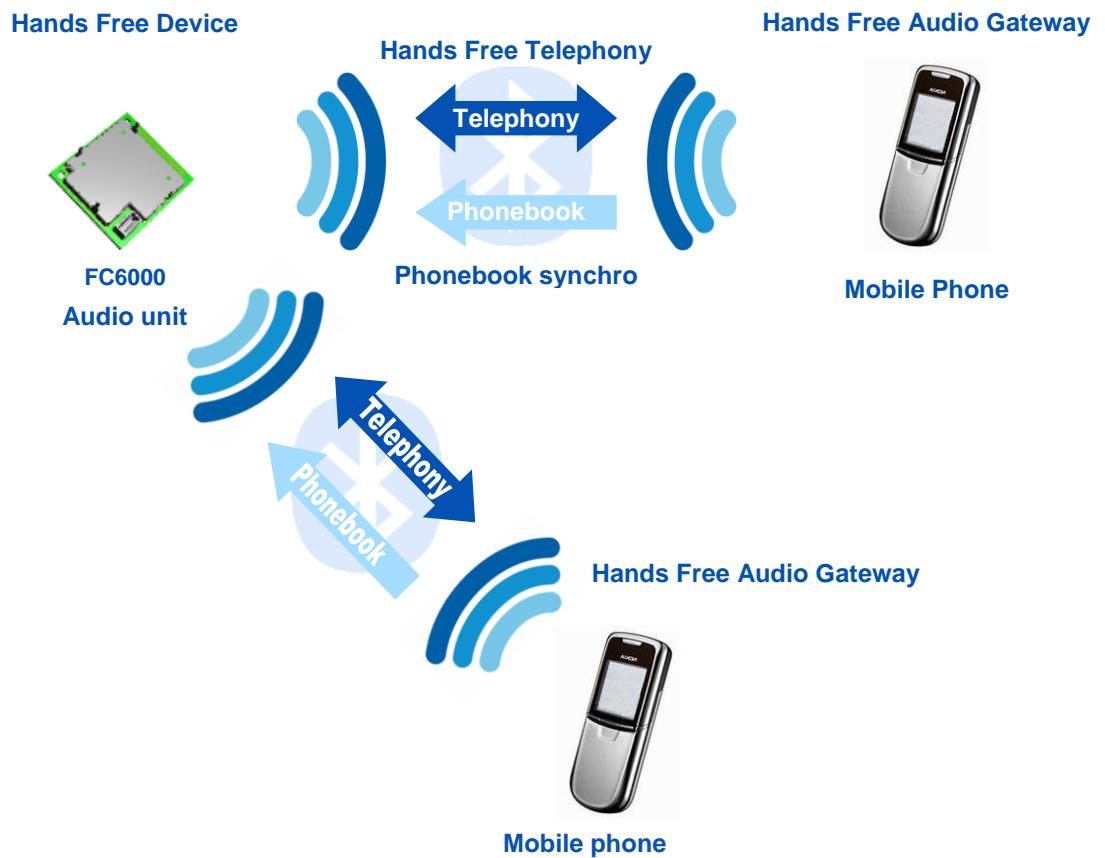

Multi HFP Feature

Parrot has developed the “Multi - HFP”, which enables the Module to handle two Handsfree connections at the same time. This use case is useful for people having two mobile phones, or when two users are in the car.

The Module is running phonebook synchronization on both phones, and each phone has its own phonebook available for the Host (phonebooks are not merged).

HFP indicators are available for each phone.

Description of the behavior:

- *First example:* two phones (P1 and P2) are connected to HFP service. The host can start dialing on P1, hang up call then start outgoing call on P2.
- *Second example:* the phone receives incoming call P1 on Module. After the end of the first call from P1 the phone P2 can receive incoming call.

The multi HFP does not manage the calls of two phones at the same time.

d. Audio Streaming and Handsfree working together

Audio Streaming from phone to Module (remotely controlled by the Module)

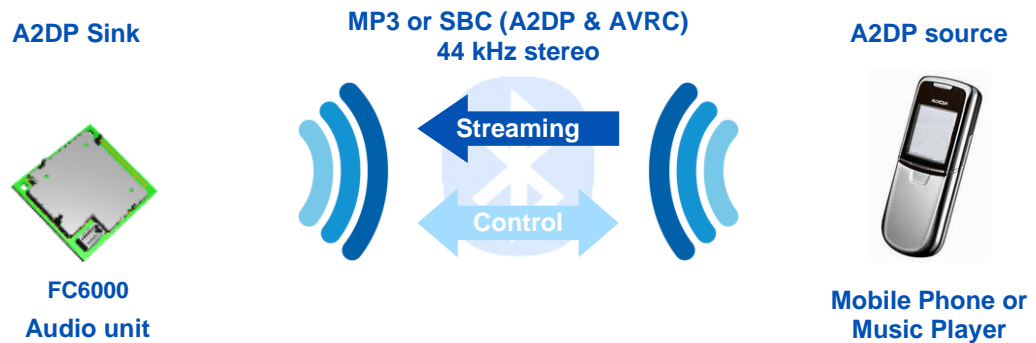

AVHFP Feature

Most phones now support both HFP and A2DP Source/AVRCP TG. The most difficult case is to correctly handle the AVHFP Feature (dual use of A2DP/AVRCP and HFP).

As there is no specification release by the Bluetooth SIG explaining how this multi-profile use case should operate, a whitepaper has been issued by the A/V Working Group ("*Simultaneous Use of HFP, A2DP, And AVRCP Profiles*").

Basically, the Whitepaper states that the phone should handle the streaming restart management once the call is finished (this is the main concern today):

- *Incoming call*: the AG should handle the streaming management:
 - o Pause the streaming on incoming call.
 - o Send to the HF the indicators (CIEV Call setup)
 - o Then the HF picks up the call with ATA, communication/SCO is established
 - o Once finished (from AG or HF), the AG should restart streaming from where it has been paused.
- *Outgoing call from HF (ATD)*: the AG should also handle this in the same manner.

Nevertheless, most phones do not correctly implement the Whitepaper, and the streaming does not always restart after the call. Parrot has developed a strategy that automatically re-launches streaming in this case.

Song information availability

According to the AVRCP version supported by the music player (can be a phone or a Bluetooth Music player), the Host is updated with the following information in order to update its HMI.

AVRCP TG 1.0 (Category 1 – Music Players):

- *Mandatory commands*:
 - o Play and stop.
- *Optional Features*:
 - o Enhanced control: Next, Previous, Pause, FF, FW (most of the phones/Players supporting AVRCP1.0 support those commands).



- There are a lot of other features, but the phone/Bluetooth Music Players do not implement these extended commands.

AVRCP CT 1.0 (Category 1 – Parrot Module):

- At least one command of the specification should be supported.
- Parrot has decided to implement the full Player Control (events send to the phone):
 - Play, Pause, Stop, Next, Previous, Pause, FF, FW

AVRCP TG 1.3 (Category 1 – Music Players):

- *Mandatory commands:*
 - Same perimeter as AVRCP TG 1.0.
- *Optional Features:*
 - If the phone supports the Bluetooth SIG Vendor Unique Feature, only Title of the Media is mandatory for Metadata. And Playback status and change of current track shall be supported in this case.
 - Other important features for Metadata support are Name of the Artist, Name of the Album, Genre...

AVRCP CT 1.3 (Category 2 – Parrot Module):

- *Mandatory commands:*
 - Same perimeter as AVRCP CT 1.0.
- *Parrot optional features implemented:*
 - Referring to the specification, all “List of Media Attributes” are supported to be displayed on the car radio HMI.

AVRCP TG 1.4 (Category 1 – Music Players)⁴:

- *Mandatory commands:*
 - Same perimeter as AVRCP TG 1.0.
- *Optional Features:*
 - If the phone supports the Bluetooth SIG Vendor Unique Feature, only Title of the Media is mandatory for Metadata. And Playback status and change of current track shall be supported in this case.
 - Other important features for Metadata support are Name of the Artist, Name of the Album, Genre...

AVRCP CT 1.4 (Category 2 – Parrot Module)⁵:

- *Mandatory commands:*
 - Same perimeter as AVRCP CT 1.0.
- *Parrot optional features implemented:*
 - Referring to the specification, all “List of Media Attributes” are supported to be displayed on the car radio HMI.

According to the AVRCP version supported by the phone, the HMI should be implemented with information provided by the Module: Player status / Metadata for the current played song.

As member of AV Working Group, Parrot is involved with the development of those specifications.

⁴ For NAND version Only

⁵ For NAND version Only

e. Head Unit paired with Mobile phone and Music Player with BT integrated or Bluetooth dongle:

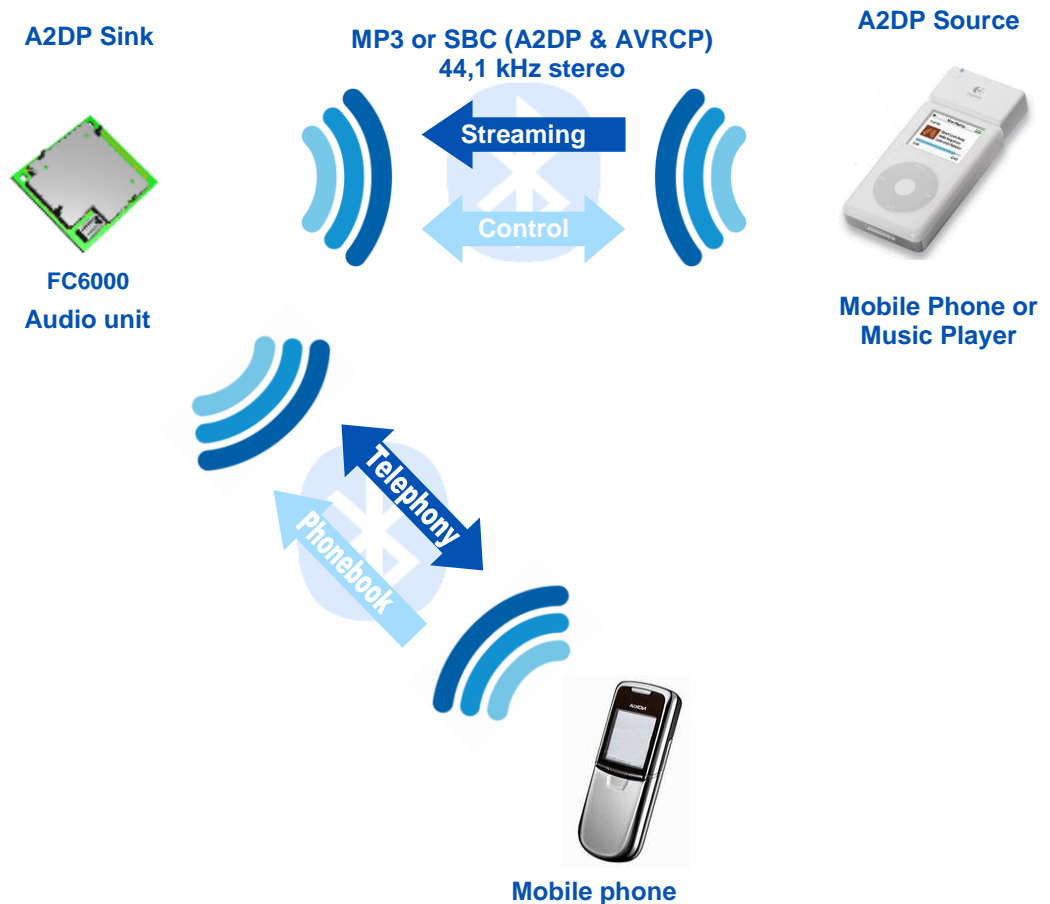

Connection Management

Parrot Module is able to maintain two Bluetooth connections: one HFP to a phone (where the phonebook synchronization is running after connection) and the other one with an A2DP SRC Music Player. From the Module point of view, there are two users connected.

As stated with the Whitepaper, in this use case, the Module handles the AVHFP because the A2DP SRC is not the connected phone. If the Bluetooth Music Player supports AVRCP TG, Parrot alerts the HMI with Playback status and Metadata.

f. Head Unit paired with a stereo Headphone

Audio Streaming from Module to a stereo headphone

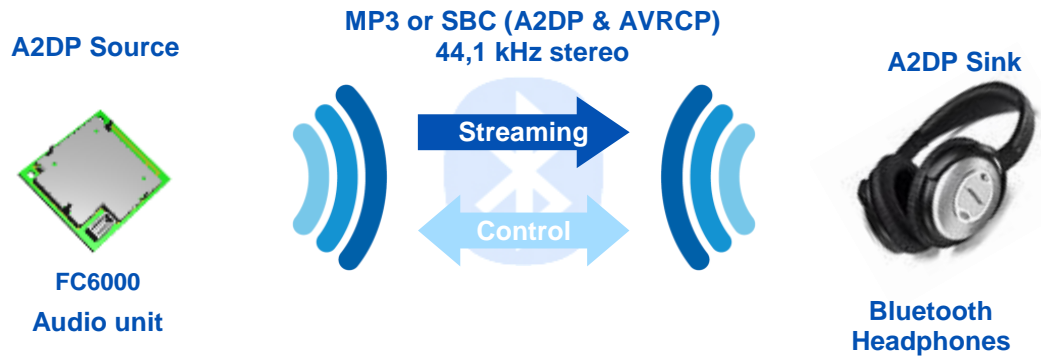

Parrot Module also embeds the A2DP SRC role, and then is able to play local music files to a Sink device.

g. Head Unit paired with Mobile phone: Data transfer

Dial Up Networking: The Head Unit acts as data terminal with a connected gateway device, typically a mobile phone.

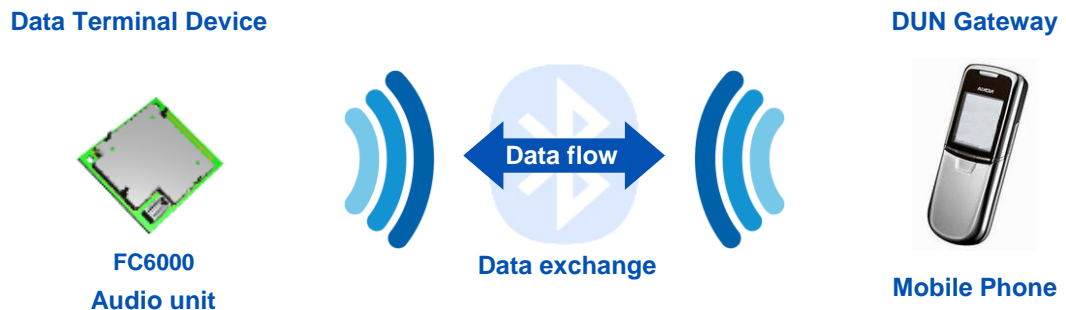

Multi Profile Use

Parrot handles multiple Bluetooth connections. On the same device, it is possible to set up both an HFP and a DUN connection.

According to the various Bluetooth implementations on phones, here is the description of what is possible (given no phone limitations):

- DUN only:
 - o In this case, the phone acts as a Gateway and the Module forwards the data to the Host (Data Terminal).
- HFP and DUN:
 - o If an incoming call occurs during the data transfer, there are three behaviors:
 - The call is established and data transfer continues without bandwidth diminution.
 - The call is established and data transfer is stopped (AG gives priority to HFP feature).
 - The distant caller reaches the voice mail of the connected phone (phone limitation).
 - o If an outgoing call is requested by the user, the behaviors above also apply.

Those behaviors are described, phone by phone in the Parrot Bluetooth Compatibility Matrix with all tested phones.

B. Head unit BT/UART software update

The firmware of Parrot modules can be updated in two different ways: by Bluetooth when paired with a Bluetooth-enabled laptop, or UART.

This is a very important feature of the Parrot Module. This ensures better Bluetooth Compatibility with new phones coming on the Market. Some of these new phones need to have a specific workaround when the Bluetooth specifications are not correctly implemented on the phone (i.e. non-generic Bluetooth management).

Moreover, a major software update can include a new feature/profile (such as AVRCP1.4 for instance) to give more compatibility or functionality to a car radio. This software update can immediately be flashed (by Bluetooth, UART...) into your product already out in the market.

After the update, user settings (paired devices, phonebooks...) are not erased. This process is transparent for the user.

Hands Free Device

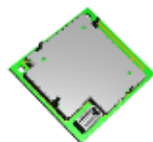

FC6000
Audio unit

Update by Bluetooth or UART

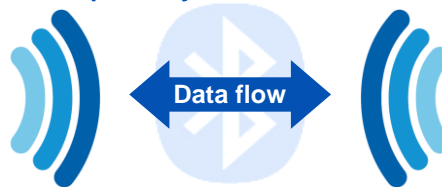

Hands Free update



Computer

Data Terminal Device

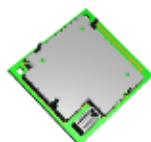

FC6000
Audio unit

Update by Bluetooth

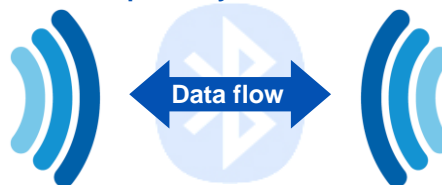

DUN Gateway



Mobile Phone

Methods available

- Bluetooth
 - o Via SPP
 - o Via FTP
- Via UART with a host CPU that send the data

Secured update mechanism

The new software is copied into the flash Module's memory but the previous software is not affected by this copy. During this process, if an error occurs before the end of file transfer (Bluetooth disconnection, data transfer stopped...), the module will restart with the previous software version.

The checksum of the new software is included into this new software. If the new file is correctly written into the flash, when Module will reboots, the new checksum internally calculated is compared the checksum of this new software. If checksum are equals, the new file will overwrite the previous one. During this process, if power supply is turned off, the remaining data will be continuing to be written where it has been stopped at the next boot.