

D900

Mobile Payment Terminal



Product Description

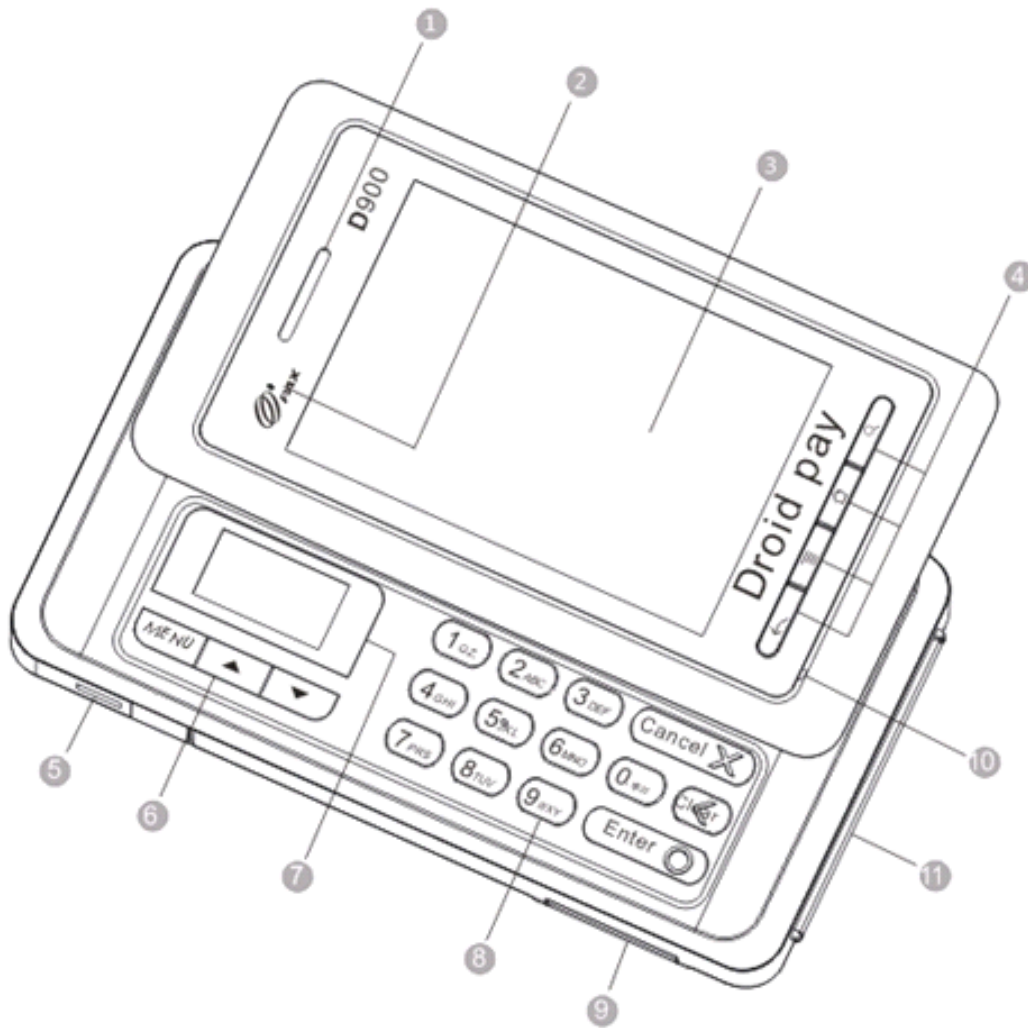

Figure 2: Front view

1. Receiver
2. LED indicator
3. Touch screen
4. Android function keys
5. USB connector
6. Pinpad function keys
7. Pinpad screen
8. Pinpad keys
9. Multi-function connector
10. Microphone
11. Smart card reader

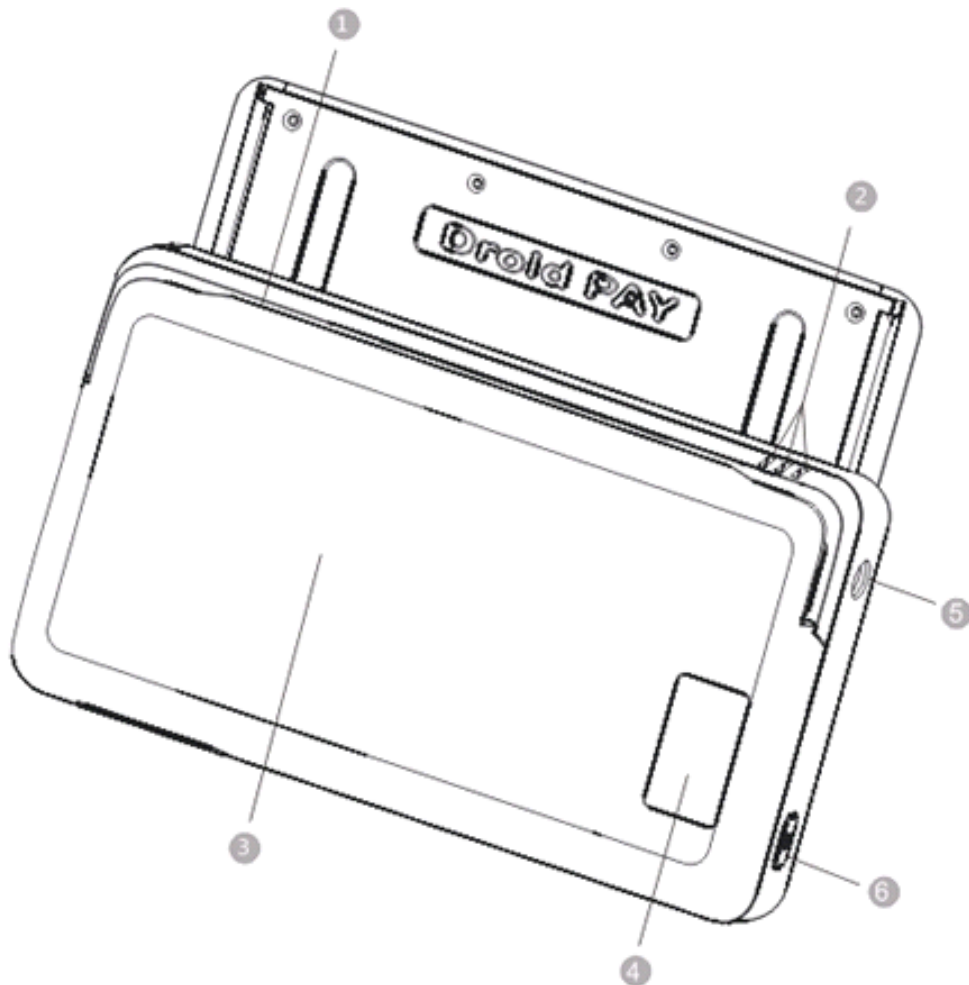
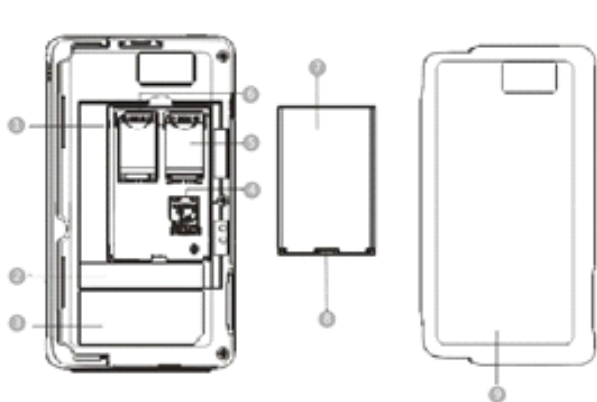

Figure 2: Back view

- 1. Magnetic stripe card reader
- 2. Speaker
- 3. Battery compartment cover
- 4. Barcode / Camera
- 5. Audio jack
- 6. POWER key



- 1. Battery slot
- 2. Barcode label
- 3. Nameplate
- 4. MicroSD slot
- 5. SAM2 slot
- 6. SAM1 slot
- 7. Battery
- 8. Battery hook
- 9. Battery compartment cover

Figure 3: SIM / SAM card slot & battery

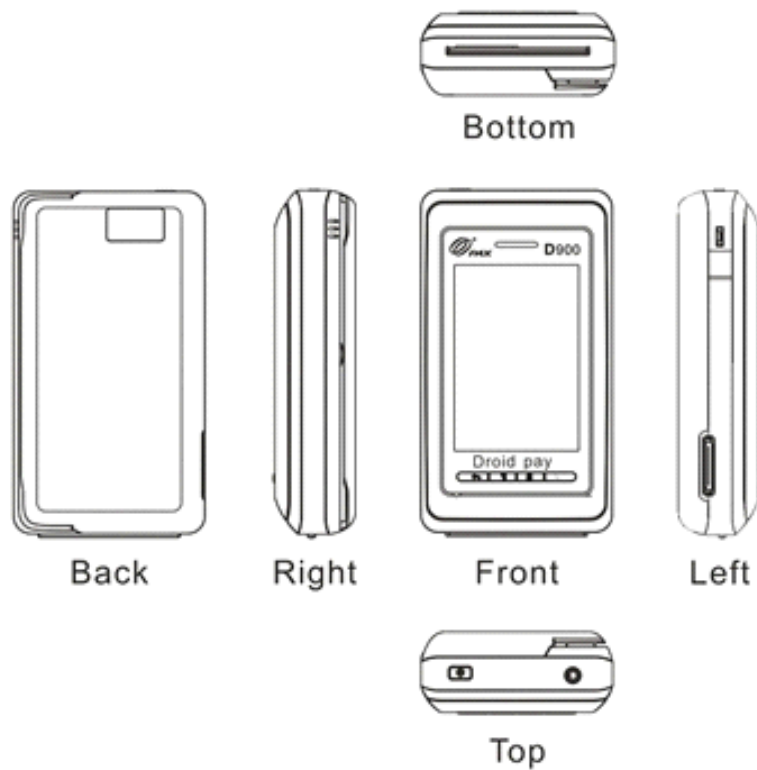

Figure 4: View from different angles

1) SAM Card

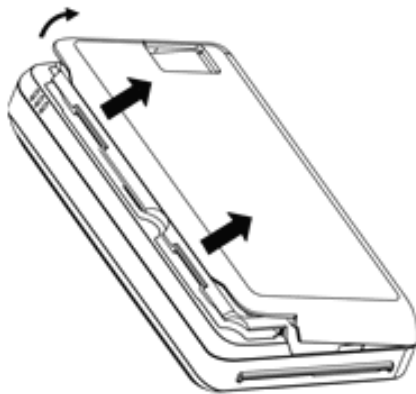

Figure 5: Take off the battery compartment cover

① Take off the battery compartment cover.

② Insert SAM card into the slot.

2) Battery

① Remove the battery compartment cover.

② Install the battery.

3) MicroSD Card

① Take off the battery compartment cover.

② Insert MicroSD card into the slot.

Instructions

1) Switch the device on / off

Switch on:

Press and hold the POWER button until the device vibrates. .

Switch off:

① Press and hold the POWER button for a few seconds. ②

When the menu appears, tap Power off.

2) Swipe magnetic stripe card



Figure 6: Swipe magnetic stripe card

When users swipe magnetic stripe card along the slot, the back of the card must be faced up as shown in Figure 6. Bi-directional swiping is supported. It is recommended to swipe from the top of the terminal to the bottom with a constant speed.

3) Read IC card

When inserting IC card into its slot, the chip of IC card must be faced up. In order to avoid any physical damage to the card or the IC slot of the terminal, it is recommended to insert the card gently. If IC card is successfully detected by the terminal, the icon of the IC card will be shown on the top of screen.

4) Tap contactless card



Figure 7: Tap Contactless Card

D900 User Manual

As shown in Figure 7: when tapping contactless card, please put the contactless card into the sensing area at the back cover of the terminal.

4) LED indicator

The LED indicator show

- ① Solid blue when the system is starting.
- ② Solid red when the battery is being charged.
- ③ Solid green when the battery is fully charged.

Specifications

CPU:	800MHz Android application processor (AP) 32-bit secure processor (SP)
Memory:	AP: 512MB FLASH, 512MB DDR SP: 8MBFLASH, 16MB SDRAM
Display:	HVGA (320×480), 3.5" TFT Touch screen
Key:	10 alphanumeric keys 4 android function keys 3 pinpad command keys 3 pinpad function keys 1 power button
Magnetic Stripe Card Reader:	Encryption transmission, triple track I/2/3, bi-directional
Smart Card Reader:	1 User card (EMV4.3)
Contactless(Opt.):	ISO14443 Type A & Type B, Mifare, Felica
SAM Slots:	2, ISO7816
Camera(Opt.):	5 mega pixel, auto focus, with flash
Barcode Scanner(Opt.):	1D barcode scanning
Communication:	Wi-Fi 802.11 b/g/n Bluetooth
Peripheral Ports:	1 RS232 (MiniUSB), 1 USB2.0 (MicroUSB) 1 Handset jack, 1 Multi-function extension port
Battery:	Li-ion battery I850mAh, 3.7V
Power Supply:	Input: 100-240VAC, 50Hz / 60Hz Output: 5VDC, 1A
Working Environment:	Temperature:0°C ~50°C (32°F~122°F) R.H.:10%~90% (non-condense)
Storage Environment:	Temperature:-20°C ~70°C (-4°F~158°F) R.H.:5%~95% (non-condense)
Dimensions:	137mm×77mm×32mm (L×W×H)
Weight:	390g (battery included)

Installation and Usage Tips

- 1) Do not damage the power cord and the adapter. If the power cord or the adapter is damaged, please do not use it any more.
- 2) Before the adapter is plugged into the socket. Please make sure that its voltage is appropriate for the terminal.
- 3) Do not expose the terminal in sunshine, or in humid, hot, and dusty environmental conditions
- 4) Keep the terminal away from liquid materials.
- 5) Do not plug any unknown material into any port of the terminal, since it may cause serious damage to the terminal.
- 6) If the terminal is defective, please contact professional POS technicians.
- 7) Do not assemble the terminal in explosive and hazardous area.

Battery Usage Tips

- 1) Charge indoor with PAX charger under cool and well ventilated conditions.
- 2) Do not dismantle the battery.
- 3) Do not short-circuit the battery.
- 4) Keep the battery away from sunshine, smog and dust.
- 5) Do not squeeze and punch the battery, and do not put it into liquid or near fire.
- 6) Keep the battery away from environmental conditions which are too hot, cold, damp and highly explosive.
- 7) Once a failure happens such as heating or distortion, or it was broken down, please replace it with a new battery.
- 8) Please replace it with a new battery if the aging phenomenon happens.
- 9) Please replace it with a new one if the battery is used more than two years accumulatively.

FCC Regulations:

● This device complies with part 15 of the FCC Rules. Operation is subject to the following two conditions: (1) This device may not cause harmful interference, and (2) this device must accept any interference received, including interference that may cause undesired operation.

● This device has been tested and found to comply with the limits for a Class B digital device, pursuant to Part 15 of the FCC Rules. These limits are designed to provide reasonable protection against harmful interference in a residential installation. This equipment generates, uses and can radiated radio frequency energy and, if not installed and used in accordance with the instructions, may cause harmful interference to radio communications. However, there is no guarantee that interference will not occur in a particular installation. If this equipment does cause harmful interference to radio or television reception, which can be determined by turning the equipment off and on, the user is encouraged to try to correct the interference by one or more of the following measures:

- Reorient or relocate the receiving antenna.
- Increase the separation between the equipment and receiver.
- Connect the equipment into an outlet on a circuit different from that to which the receiver is connected.
- Consult the dealer or an experienced radio/TV technician for help.

Changes or modifications not expressly approved by the party responsible for compliance could void the user's authority to operate the equipment.

▶ RF Exposure Information

This device meets the government's requirements for exposure to radio waves. This device is designed and manufactured not to exceed the emission limits for exposure to radio frequency (RF) energy set by the Federal Communications Commission of the U.S. Government.