

## Q80 Countertop Payment Terminal

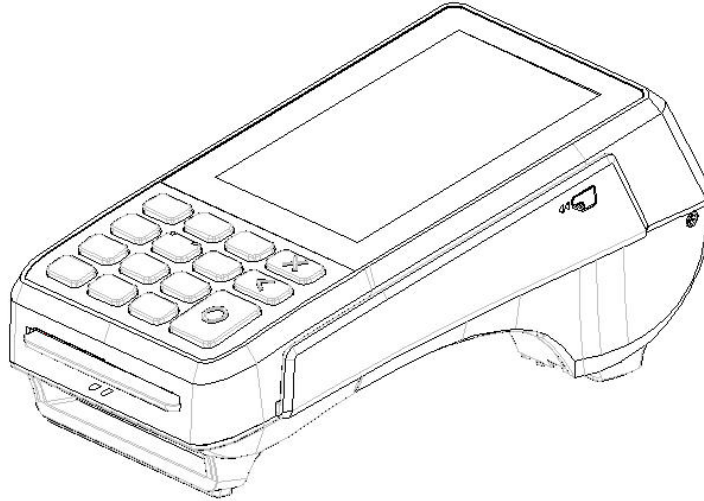

**PAX TECHNOLOGY LIMITED**

## 1. Product Description:

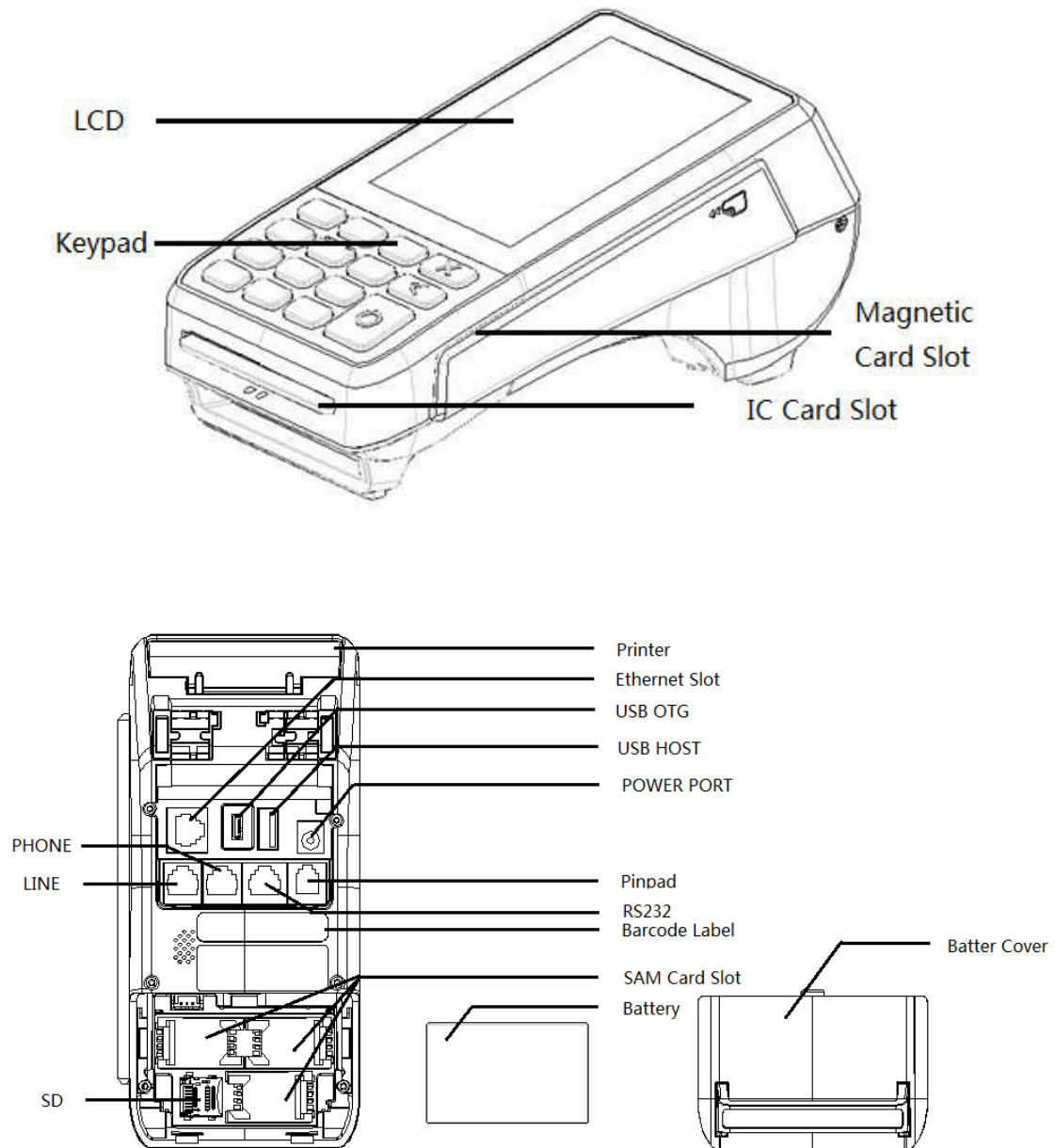

## 2. Installation

### 1) SAM Card Installation

- ① Open up battery cover, which is at the bottom of the terminal;
- ② Take out battery;
- ③ Insert SAM card to corresponding SAM card slot.

### 2) SD Card Installation

- ① Open up battery cover, which is at the bottom of the terminal;
- ② Take out battery;
- ③ Insert SD card to corresponding SD card slot.

### 3) Battery Installation

- ① Hold the battery with its sticker facing up;
- ② Attach battery forelock to battery bayonet;
- ③ Press down the other side of the battery

## 3. Instruction

### 1) Power ON/OFF

Power on: Plug adapter. Press “CANCEL” button for 3 seconds until LED backlight is on, if POS terminal is being turned on successfully.

Power off: Press “CANCEL” button for 3 seconds until the displaying content vanishes. POS terminal is being turned off.

### 2) Magnetic Stripe Card

When user swipes magnetic stripe card along the slot, the backside of the card, which contains magnetic stripe information, should be facing to the terminal. Bi-directional swiping is supported. It is recommended to swipe starting from the top of the terminal to the bottom of the terminal with a constant moving speed.

### 3) IC card

When user inserts IC card into the IC slot, the chip of IC card should be facing up; user is recommended to gently insert the card, in order to avoid any physical damage to the card or the IC slot of the terminal. If IC card is successfully read by the terminal, the IC card icon will be shown on LCD display screen.

## ICC Operation Process

Before inserting the IC card, please check inside and around the IC card slot. If there is any suspicious object, please don't insert card and immediately report to the relevant staff.

### 4) Tearing off receipt from the terminal

After the receipt is printed, pinch the end of the receipt and keep an angle of 45 degrees between receipt and the cutter of the terminal; tear off the receipt swiftly.

## 4. Specifications

### Default

CPU: 32-bit, Cortex-A9

Memory: 512MB DDR RAM , 512MB NAND Flash

Display: 4 -inch 480x800 pixel color TFT LCD; LED backlight;

Touch Screen: support Electronic signature

Keypad: 10 alphanumeric keys,5 functional keys

Magnetic Card Reader : Track 1/2/3, bi-directional swipe

IC Card Reader: 1 user card (EMV2000)

SAM and SD slots:

SAM slot × 3 SD slot × 1

Communication: MODEM,Ethernet or WiFi-BT

Peripheral Ports: 1 RS232 port

2USB port

1 Power Charge port

1 LAN port

1 Phone port

1 Line port

1 Pinpad port

Printer : Thermal printer; Speed: 30 lines/sec; Paper width:58mm  
Paper roll outside diameter:40mm

Power Supply: Input: 100—240VAC , 0.6A 50/60HZ  
Output: 9.0V DC1A

Battery: Li-ion battery,720mAh,7.4V

Working Environment: Temperature: 0 °C~50°C(32°F~122°F)  
R.H.: 10%~93%(non-condense)

Storage Environment: Temperature:-20°C ~ 70°C (-4°F~158°F)  
R.H.:5%~95%(non-condense)

Dimensions: L181\*W83.5\*H72

Weight: 440g

### **5. Installation and Usage Tips**

- 1) Do not damage electric wire and power adapter. If electric wire or power adapter is damaged , please do not use the terminal any more.
- 2) Before power adapter is plugged into power socket, please make sure that voltage which the power socket supplies is appropriate working voltage for the terminal.
- 3) Do not expose the terminal in sunshine, or in humid, hot, or dusty environment
- 4) Keep the terminal away from liquid material
- 5) Do not plug any unknown material into any port of the terminal, since it may create serious damage to the terminal.
- 6) If the terminal is defective, please contact professional POS repair technicians.
- 7) When installing paper roll, please be aware of the cutter within paper bracket.
- 8) Please use standard thermal paper, in order to protect the printer and avoid paper jam.
- 9) Do not assemble the terminal in explosion hazardous area.

### **6. Battery Usage Tips**

- 1) Charge indoor by PAX charger, where is cool and well ventilated;
- 2) Do not apart the battery;
- 3) Do not short circuit the battery;
- 4) Keep the battery away from sunshine, smog and dust;
- 5) Do not squeeze, punch the battery, put it into liquid or near fire;
- 6) Keep away from environment which is too hot , too cold, damp and highly explosive;
- 7) Once a failure happens such as heating or distortion, or it was broken down. Please change new battery;
- 8) Change new battery if it cannot satisfy your requirement;
- 9) Change new battery if using more than two years.

## **FCC Regulations:**

This device complies with part 15 of the FCC Rules. Operation is subject to the following two conditions: (1) This device may not cause harmful interference, and (2) this device must accept any interference received, including interference that may cause undesired operation.

This device has been tested and found to comply with the limits for a Class B digital device, pursuant to Part 15 of the FCC Rules. These limits are designed to provide reasonable protection against harmful interference in a residential installation. This equipment generates, uses and can radiate radio frequency energy and, if not installed and used in accordance with the instructions, may cause harmful interference to radio communications. However, there is no guarantee that interference will not occur in a particular installation. If this equipment does cause harmful interference to radio or television reception, which can be determined by turning the equipment off and on, the user is encouraged to try to correct the interference by one or more of the following measures:

- Reorient or relocate the receiving antenna.
- Increase the separation between the equipment and receiver.
- Connect the equipment into an outlet on a circuit different from that to which the receiver is connected.
- Consult the dealer or an experienced radio/TV technician for help.

Caution: Changes or modifications not expressly approved by the party responsible for compliance could void the user's authority to operate the equipment.

## **FCC RF Exposure Information (SAR)**

This device is designed and manufactured not to exceed the emission limits for exposure to radio frequency (RF) energy set by the Federal Communications Commission of the United States.

During SAR testing, this device is set to transmit at its highest certified power level in all tested frequency bands, and placed in positions that simulate RF exposure in usage near the body. Although the SAR is determined at the highest certified power level, the actual SAR level of the while operating can be well below the maximum value. This is because the device is designed to operate at multiple power levels so as to use only the power required to reach the network. In general, the closer you are to a wireless base station antenna, the lower the power output.

The exposure standard for wireless employs a unit of measurement known as the Specific Absorption Rate, or SAR. The SAR limit set by the FCC is 1.6W/kg.

The FCC has granted an Equipment Authorization for this model device with all reported SAR levels evaluated as in compliance with the FCC RF exposure guidelines. SAR information on this model device is on file with the FCC and can be found under the Display

Grant section of [www.fcc.gov/oet/ea/fccid](http://www.fcc.gov/oet/ea/fccid) after searching on FCC ID: V5PQ80

For this device, the highest reported SAR value for near the body is <0.10W/kg.

While there may be differences between the SAR levels of various devices and at various positions, they all meet the government requirement.

The REN is used to determine the quantity of devices which may be connected to the telephone line. Excessive REN's on the telephone line may result in the devices not ringing in response to an incoming call. In most, but not all areas, the sum of the REN's should not exceed five (5.0). To be certain of the number of devices that may be connected to the line, as determined by the total REN's contact the telephone company to determine the maximum REN for the calling area.

This equipment cannot be used on the telephone company-provided coin service. Connection to Party Line Service is subject to State Tariffs.

If this equipment causes harm to the telephone network, the telephone company will notify you in advance that temporary discontinuance of service may be required. If advance notice isn't practical, the telephone company will notify the customer as soon as possible. Also, you will be advised of your right to file a complaint with the FCC if you believe it is necessary.

The telephone company may make changes in its facilities, equipment, operations, or procedures that could affect the operation of the equipment. If this happens, the telephone company will provide advance notice in order for you to make the necessary modifications in order to maintain uninterrupted service.

Name	PAX Technology Inc.
Address	560 Broadhollow Road, Suite 100 Melville, New York 11747
Telephone	631247-9660
Web site	<a href="http://www.pax.us">www.pax.us</a>

P/N: 200312000000189