



Specifications

4

Default

| | |
|----------------------|--|
| CPU: | 32-bit, ARM7 |
| Memory: | 2MB FLASH, 8MB SDRAM |
| LED Indicator: | 4 (Red, Yellow, Blue and Green) |
| RF: | ISO/IEC 14443 and qPBOC 2.0 compliant |
| Buzzer: | 70dB |
| Peripheral Port: | RS232 |
| Power Supply: | 5V DC, 500mA |
| Working Environment: | Temperature: 0°C~50°C R.H.: 10%~90%(non-condense) |
| Storage Environment: | Temperature: -20°C~60°C R.H.: 10%~90%(non-condense) |
| Dimensions: | Reader: 122mmX85mmX85mm (L×W×H) |
| Weight: | 160g |

PAX TECHNOLOGY LIMITED reserves the right to change product technology specifications without notifying.



PAX TECHNOLOGY LIMITED

Harbour Road, Wanchai, Hong Kong
 Tel: +852-2588 8808 Fax: +852-2802 3300
 E-mail: daniel@pax.com.Room 2416, 24/F.,
 Sun Hung Kai Centre, 30 hk
 Website: www.pax.com.hk

Usage Tips

5

- 1) Please make sure that card reader is working under specified range of voltage, which is not too high and not too low.
- 2) Correctly connect the contactless card with other devices.
- 3) Do not damage the power cable. If power cable is damaged, please stop using the contactless card reader.
- 4) Do not expose the reader in sunshine, or in humid, hot, dusty or corrosive environment.
- 5) Keep the terminal away from liquid material.
- 6) If the contactless card reader is defective, please contact professional POS repair technicians.



R30

Contactless Reader(with base)

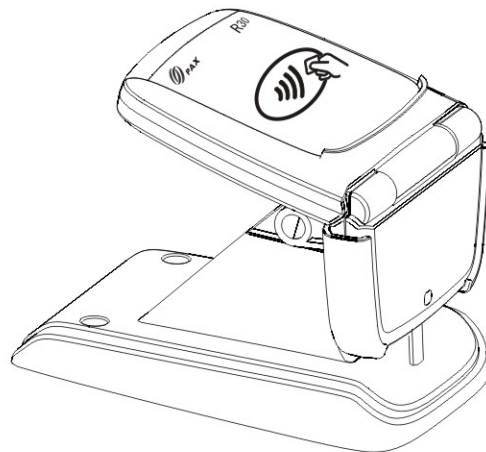

Product Description

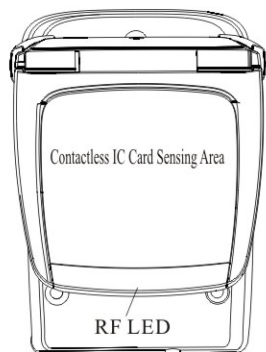
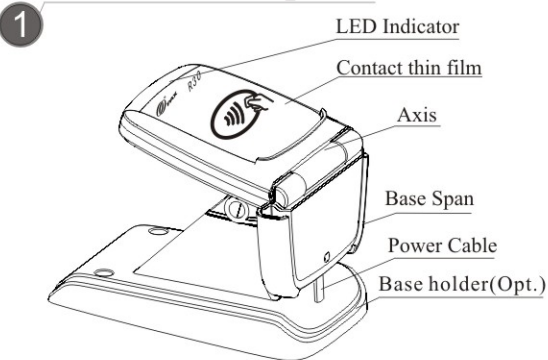

1

Descriptions:

LED Indicator: Transaction status can be indicated by four different colors, which are blue, yellow, green and red, respectively. User can define and program according to their requirements.

Contactless IC Card Sensing Area: Contactless card will be placed right above the sensing area, when the card is being read.

Power Cable: Contactless card reader will be connected to PAX POS terminal.

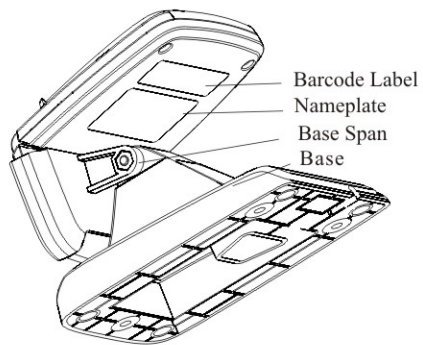

2

Descriptions:

Screw: 2, used for installing base span to POS terminal.

Base Span: 2 M2.5 screws will be used for installing base span to POS terminal, and R30 will be fastened to the base span. Power cable is connected to the serial port of POS terminal.

Barcode Label and Nameplate: Terminal type, rated parameters and serial number can be found on barcode label and nameplate.

Base: Base is placed on the desk, R30 reader is installed onto base through base span, Insert the cable to POS serial port .

Installation

- 2) For base span installation, please refer to the following figure:

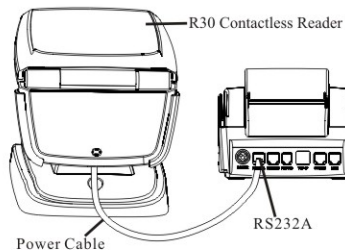

3

Instruction

- 3) Power ON/OFF Card Reader
- Power ON:** Card reader will be automatically powered on after power cable is inserted into RJ45/RJ11 jack of POS terminal, which has been turned on.
- Power OFF:** Card reader will be automatically powered off after power cable is unplugged from RJ45/RJ11 jack of POS terminal, or turns off POS terminal.
- 2) Contactless IC card
- Put contactless IC card right above the Contactless IC Card Sensing Area for 0.5 second, and the sensing distance between the card and the reader is recommended to be less than 4 cm

4

Federal Communication Commission Interference Statement

This equipment has been tested and found to comply with the limits for a Class B digital device, pursuant to Part 15 of the FCC Rules. These limits are designed to provide reasonable protection against harmful interference in a residential installation. This equipment generates, uses and can radiate radio frequency energy and, if not installed and used in accordance with the instructions, may cause harmful interference to radio communications. However, there is no guarantee that interference will not occur in a particular installation. If this equipment does cause harmful interference to radio or television reception, which can be determined by turning the equipment off and on, the user is encouraged to try to correct the interference by one or more of the following measures:

- Reorient or relocate the receiving antenna.
- Increase the separation between the equipment and receiver.
- Connect the equipment into an outlet on a circuit different from that to which the receiver is connected.
- Consult the dealer or an experienced radio/TV technician for help.

FCC Caution: Any changes or modifications not expressly approved by the party responsible for compliance could void the user's authority to operate this equipment.

This device complies with Part 15 of the FCC Rules. Operation is subject to the following two conditions: (1) This device may not cause harmful interference, and (2) this device must accept any interference received, including interference that may cause undesired operation.

This device and its antenna(s) must not be co-located or operating in conjunction with any other antenna or transmitter.