

4.2 UHF Channel Selective Cell Enhancer Rack (50-146601)

4.2.1 Description

The UHF cell enhancer in this system is a six channel, duplex only, two-way radio repeater rack with automatic gain control of both up and downlink paths. A dedicated power supply provides all the DC needed by the whole rack, driven from the local mains supplies (identical with PSU in VHF cell enhancer rack). Alarms are provided from each active device and all are 'looped' to form a normally closed fail-safe alarm (locally for each shelf and globally for the whole enhancer). This loop alarm is easily configured to join any other similarly wired system.

4.2.2 Electrical Specification

PARAMETER	SPECIFICATION
UHF frequencies:	453.7500MHz
	465.0375MHz
	471.2625MHz
	479.8375MHz
	481.0375MHz
	485.6375MHz
	458.7500MHz
	460.0375MHz
	470.7125MHz
	474.2625MHz
	476.8375MHz
	484.0375MHz
Gain Adjustment:	0 - 30dB (in 2dB steps)
Gain Adjustment:	0 – 15dB (in 1dB step)
Uplink Power:	5 Carriers @ +24dBm
Downlink Power:	5 Carriers @ +27dBm
AGC:	Fitted in all channel selective modules
In-Band Spurious:	Better than –13dBm (measured with 30KHz BW with max gain setting)
Noise Figure:	<6dB (@ maximum gain)
VSWR:	better than 1.5:1
Impedance:	50Ω
Alarms Fitted: (volt-free contacts/TTL)	1 Amplifiers 2 PSU

4.2.3 Mechanical Specification

PARAMETER	SPECIFICATION
Rack	Height: 43U Standard Eldon Vented Rack
	Width: 19" (482.6mm)
	Depth: 600mm
Shelves:	Height: See shelves parts lists
	Width: 19" (482.6mm)
	Depth: <450mm(excluding heatsinks, connectors, handles and feet)
Temperature range:	operational: -20°C to +60°C
	storage: -40°C to +70°C
Weight:	>100kg
Humidity:	5 – 95% non-condensing
RF Connectors:	N type female
Environmental protection:	IP44
Supply cable:	Dedicated PSU shelf supply cable

4.2.4 Parts List

AFL Part Nö.	Part Description	Qty.
50-146512	VHF/UHF SYSTEM PSU 24v	1
50-146602	UHF DOWNLINK COMBINER	1
50-146603	UHF UPLINK SPLITTER	1
50-146604	UHF DUPLEX BDA CHN1	1
50-146605	UHF DUPLEX BDA CHN2	1
50-146606	UHF DUPLEX BDA CHN3	1
50-146607	UHF DUPLEX BDA CHN4	1
50-146608	UHF DUPLEX BDA CHN5	1
50-146609	UHF UPLINK COMBINER	1
50-146610	UHF DOWNLINK SPLITTER	1
50-146612	UHF DUPLEX BDA CHN6	1
80-054020	600mm DEEP SUPPORT BRACKET	22
80-063654	1U BLANKING PANEL (BS) RAL 7035	4
90-100011	IEC MAINS LEAD '6 AMP' for USA	1
91-000002	N PLUG RG223:U	58
91-030002	N ADAPTOR PANEL FEMALE:FEMALE	4
97-500175	ELDON 43U 600 x 600 RACK (VENTED LID)	1
99-000082	PALLET 900 x 900 x 7ply FOR RACKS	1

4.2.5 Downlink Combiner Shelf (50-146602)

4.2.5.P Downlink Combiner Photographs

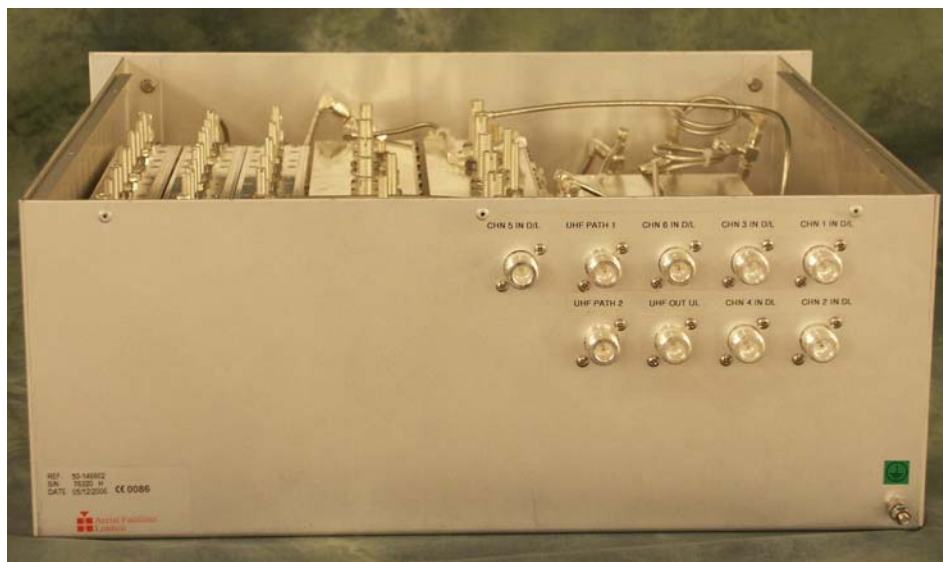
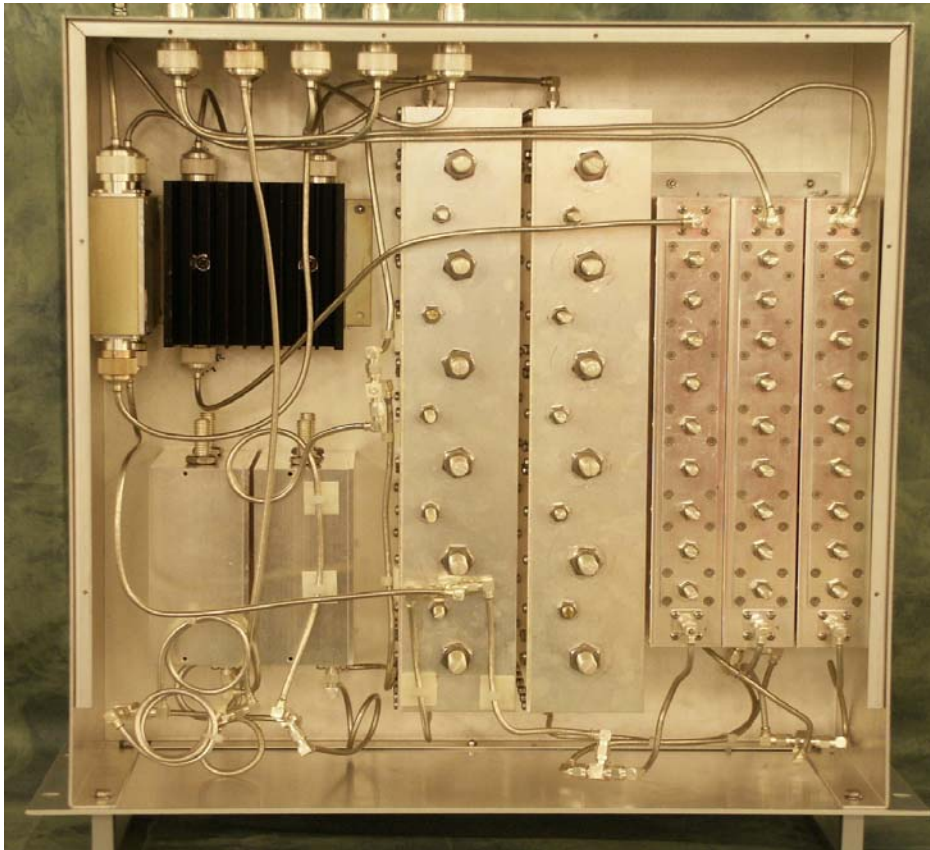

4.2.5.1 Description

The UHF downlink combiner shelf receives signals from the outputs of the six BDA shelves and combines them using a series of bandpass, notch filters and hybrid couplers. The two UHF outputs then directly drive the leaky feeder antennas. This is a passive only shelf and has no need of a power source or alarms.

4.2.5.2 Technical Specification

PARAMETER		SPECIFICATION
DC power consumption:		None
Chassis height:		4U
IP protection:		IP44
Relative humidity range:		5-95%
Impedance:		50Ω
Alarms:		None
Temperature Range:	operation:	-10°C to +60°C
	storage:	-30°C to +70°C
Finish:	Case:	Alocrom 1200/Iridite NCP
	Heatsinks:	None
	Fascia:	Painted to RAL7035
	Handles:	Silver anodise

4.2.5.3 Parts List

AFL Part Nō.	Part Description	Qty.
02-007309	SDF C/L5P VAR.BW TOP SMA 50mm POST	3
02-013401	6P CL FLTR(0.5 min BW) LARGE SMA ASSY	2
02-020001	UHF 2 LN NOTCH FILTER SMA	3
05-000101	TRANSMITTER HYBD COUPL.4 PORT	1
05-000104	TRANS.HYBRD.COUPL.3 PORT 50W INT.L	1
19-001022K	4U CHASSIS KIT (450mm deep)	1
91-030002	N ADAPTOR PANEL FEMALE:FEMALE	9
91-130001	SMA ADAPT 'T' ALL FEMALE 3 GHz	5

4.2.5.4 System Diagram, Drg. # 50-146682

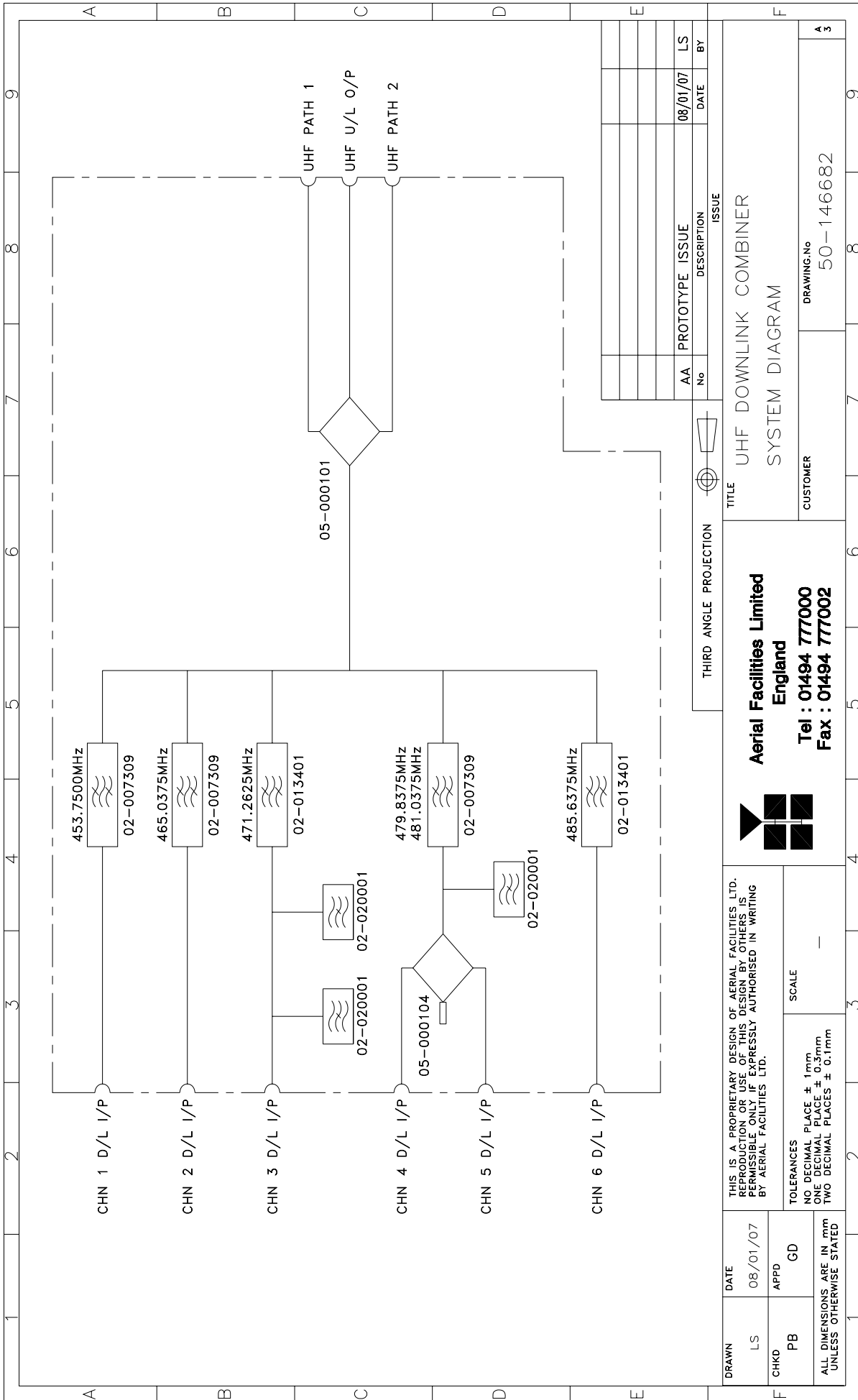

4.2.6 Uplink Splitter Shelf (60-146603)

4.2.6.P Uplink Splitter Shelf Photographs

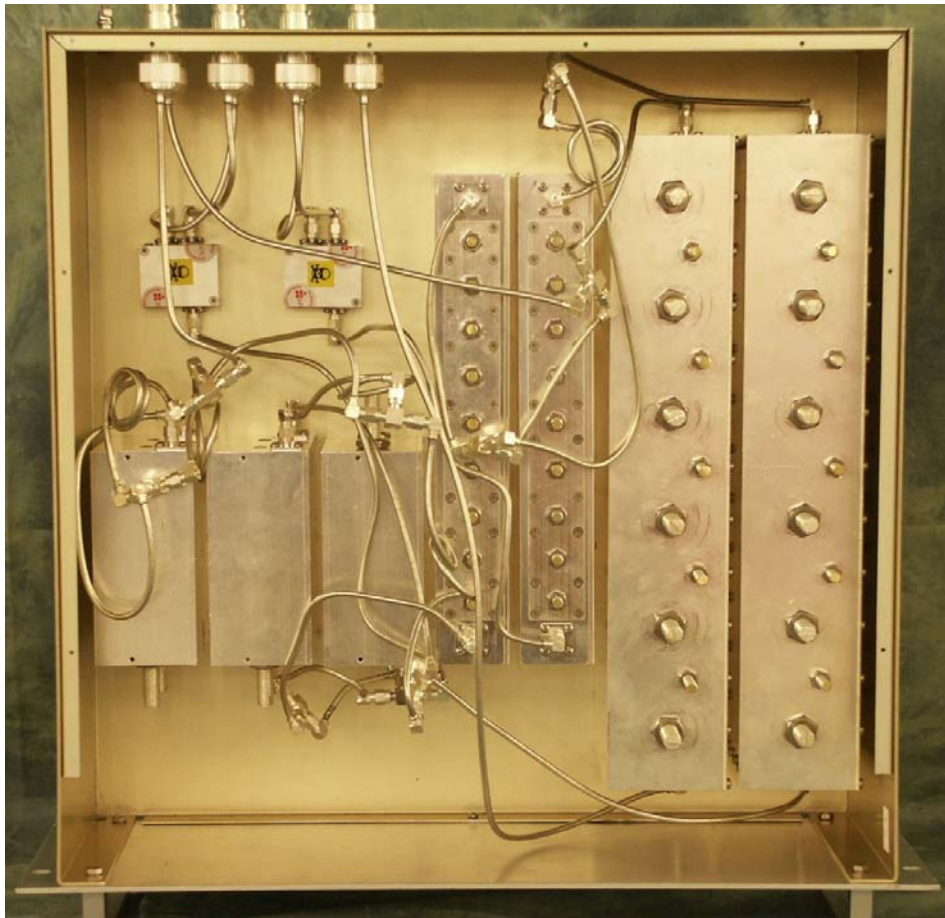

4.2.6.1 Description

The UHF uplink splitter receives a single RF source (from the leaky feeder antenna(s) and directs it through hybrid couplers, bandpass and notch filters to the inputs of the UHF uplink BDA shelves. This is a passive only shelf and has no need of a power source or alarms.

4.2.6.2 Technical Specification

PARAMETER		SPECIFICATION
DC power consumption:		None
Chassis height:		4U
IP protection:		IP44
Relative humidity range:		5-95%
Impedance:		50Ω
Alarms:		None
Temperature Range:	operation:	-10°C to +60°C
	storage:	-30°C to +70°C
Finish:	Case:	Alocrom 1200/Iridite NCP
	Heatsinks:	None
	Fascia:	Painted to RAL7035
	Handles:	Silver anodise

4.6.2.3 Parts List

AFL Part Nō.	Part Description	Qty.
02-007302	SDF C/L5P VAR.BW TOP SMA 40 mm POST	1
02-007309	SDF C/L5P VAR.BW TOP SMA 50mm POST	1
02-013401	6P CL FLTR (0.5 min BW) LARGE SMA ASSY	2
02-020001	UHF 2 LN NOTCH FILTER SMA	3
05-002603	UHF 3DB SPLITTER SMA	2
19-001022K	4U CHASSIS KIT (450mm deep)	1
91-030002	N ADAPTOR PANEL FEMALE:FEMALE	7
91-130001	SMA ADAPT 'T' ALL FEMALE 3 GHz	3

4.2.6.4 System Diagram, Drg. # 50-146683

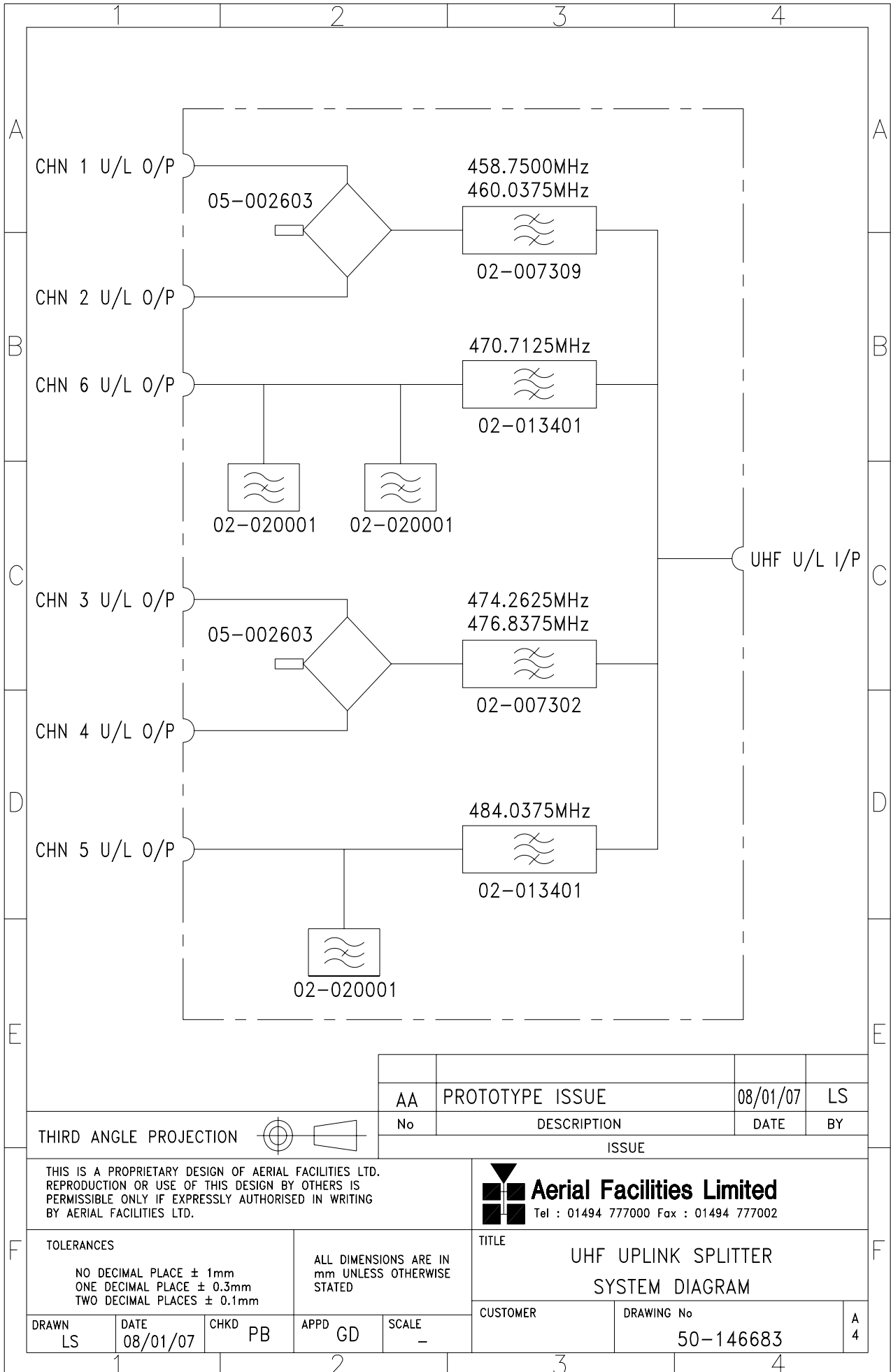

AA	PROTOTYPE ISSUE	08/01/07	LS
No	DESCRIPTION	DATE	BY
ISSUE			

THIRD ANGLE PROJECTION

THIS IS A PROPRIETARY DESIGN OF AERIAL FACILITIES LTD. REPRODUCTION OR USE OF THIS DESIGN BY OTHERS IS PERMISSIBLE ONLY IF EXPRESSLY AUTHORISED IN WRITING BY AERIAL FACILITIES LTD.

Aerial Facilities Limited
Tel : 01494 777000 Fax : 01494 777002

TOLERANCES
NO DECIMAL PLACE ± 1mm
ONE DECIMAL PLACE ± 0.3mm
TWO DECIMAL PLACES ± 0.1mm

ALL DIMENSIONS ARE IN mm UNLESS OTHERWISE STATED

TITLE
UHF UPLINK SPLITTER
SYSTEM DIAGRAM

DRAWN LS	DATE 08/01/07	CHKD PB	APPD GD	SCALE -	CUSTOMER	DRAWING No 50-146683	A 4
-------------	------------------	------------	------------	------------	----------	-------------------------	--------

4.2.7 UHF Duplex Channel 1 BDA (50-146604)

4.2.7.P Duplex Shelf Photographs (hardware identical, only 1 shelf shown)

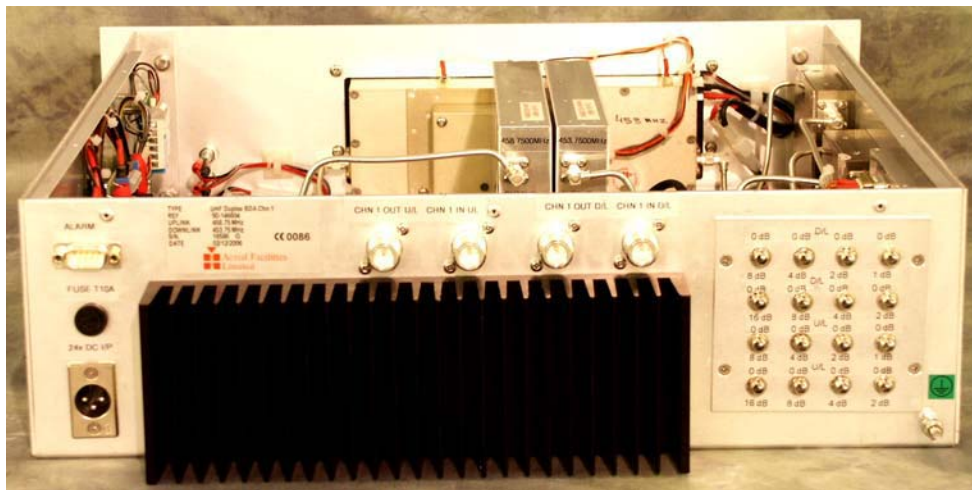
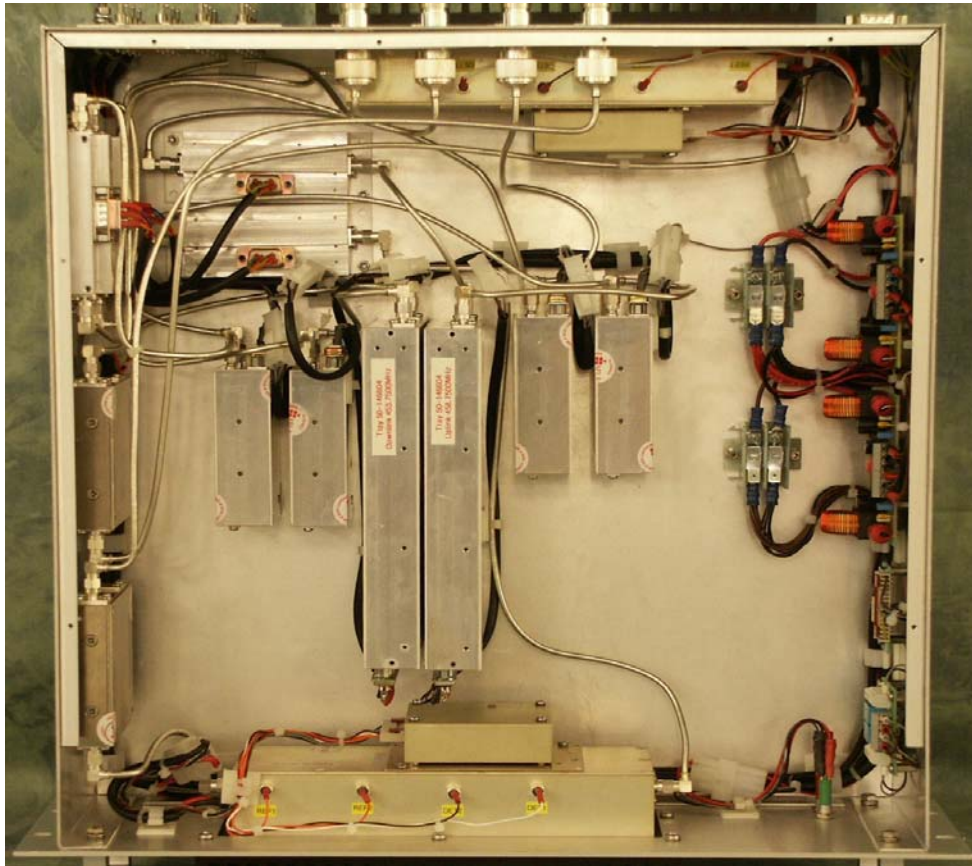

4.2.7.1 Description

The BDA shelves amplify the UHF digital signals at specific frequencies, selected by the channel control modules. They each have a gain of approximately 95dB and switched attenuators after the input amplifier and at the output so that channels may be individually set up for the best signal levels at the time of installation.

4.2.7.2 Technical Specification

PARAMETER		SPECIFICATION	
UHF Frequencies:		453.750MHz (Ch. 1)	UHF downlink
		465.0375MHz (Ch. 2)	
		472.2675MHz (Ch. 3)	
		479.8375MHz (Ch. 4)	
		484.0375MHz (Ch. 5)	
		470.7125	
		458.750MHz (Ch. 1)	UHF uplink
		460.0375MHz (Ch. 2)	
		471.2625MHz (Ch. 3)	
		476.8375MHz (Ch. 4)	
		481.0375MHz (Ch. 5)	
		485.6375MHz (Ch. 6)	
Bandwidth:		15kHz (up & downlink)	
Shelves	Height:	3U	
	Width:	19" (482.6mm)	
	Depth:	<450mm (excluding heatsinks, connectors, handles and feet)	
Downlink Gain(Duplexed):		95dB min	
Gain Adjustment:		0 – 15dB (in 1dB step)	
Uplink Power:		>10Watts	
Downlink Power:		>10Watts	
AGC:		Fitted in all channel selective modules	
Noise Figure:		<6dB (@ maximum gain)	
VSWR:		better than 1.5:1	
Impedance:		50Ω	
RF Connectors:		N type, female	
Supply voltage:		24V DC (nominal from PSU shelf)	
System power requirement:		24V DC @ <10A (fuse rating)	
Alarms Fitted: (volt-free contacts/TTL)		1	Amplifiers
		2	Channel modules

4.2.7.3Parts List

AFL Part Nö.	Part Description	Qty.
08-930003	2 PORT ISOLATOR 360-470MHz SMA	2
10-000701	1/4W0-30dB SWITCHED ATTENUATOR	2
10-000901	SW. ATTENUATOR 0.25W 0-15dB	2
11-007302K	LNA. 380-500MHz 20dB (relay) KIT	2
11-007402K	LNA. 380-500MHz 30dB (relay) KIT	2
12-001806	400MHz 10W CLASS AB POWER AMPLIFIER	2
12-002201	3 STAGE AMPLIFIER ALARM BOARD	2
12-002220	3 STAGE ALARM PCB COVER	2
12-002826	ALARM BOARD ACRYLIC LENS	2
13-001803	DUAL DC/DC CONVERTER 24V-12V 1A	2
13-001822	DC-DC CON 24V-5V/15V COVER	2
17-004730	ATTENUATOR MOUNTING	4
17-010809	CHAN MOD 450MHz 30kHz 8p GATED O/P	2
19-000922KL	3U chassis kit 450 deep with led	1
20-001601	12V RELAY BOARD	1
80-008901	12V RELAY PCB ASSEMBLY **NO LED**	1
80-063920	HEATSINK 2U ASS140 (5W)	2
91-030002	N ADAPTOR PANEL FEMALE:FEMALE	4
91-500001	POWER PLG 3 PIN PNL.MOUNT NC-X	1
91-510003	3 PIN R.ANGLE FREE SOC.NC-X.	1
91-600001	'D'TYPE 9 WAY PLUG S/B TERM	1
91-620001	'D' 25 WAY SOCKET S/B TERM	2
91-700017	ICD 15 WAY 0.1' CONNECTOR	3
96-100001	20 x 5mm,10A FUSE HOLDER/CARRIER	1
96-110012	T 10A A.SURGE FUSE 20mm	1
96-600002	INSULATING BOOT SMALL	1
96-600003	INSULATING BOOT D.C.	1

4.2.7.4UHF Duplex Channel 1 BDA System Diagram Drg. # 60-146684

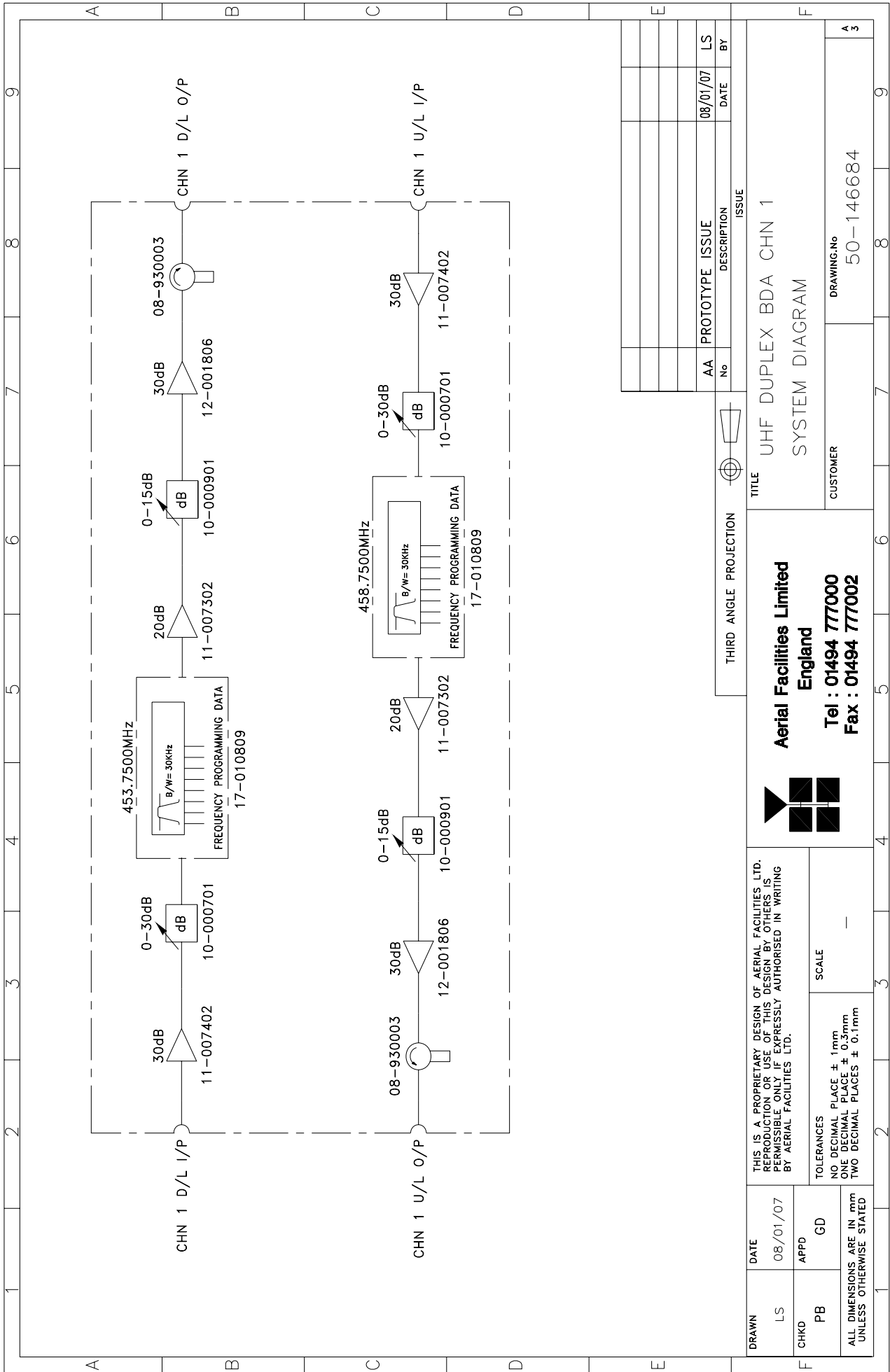

AA	PROTOTYPE	ISSUE	LS
No		DESCRIPTION	BY
		DATE	

THIRD ANGLE PROJECTION		TITLE	
UHF DUPLEX BDA CHN 1		SYSTEM DIAGRAM	
CUSTOMER		DRAWING.No	
Aerial Facilities Limited England		50-146684	
Tel : 01494 777000			
Fax : 01494 777002			
THIS IS A PROPRIETARY DESIGN OF AERIAL FACILITIES LTD. REPRODUCTION OR USE OF THIS DESIGN BY OTHERS IS PERMISSIBLE ONLY IF EXPRESSLY AUTHORISED IN WRITING BY AERIAL FACILITIES LTD.		SCALE	
TOLERANCES		NO. DECIMAL PLACES ± 1mm	
		ONE DECIMAL PLACES ± 0.3mm	
		TWO DECIMAL PLACES ± 0.1mm	
ALL DIMENSIONS ARE IN mm UNLESS OTHERWISE STATED		DATE	
DRAWN		08/01/07	
LS		APPD	
PB		GD	

4.2.8 UHF Duplex Channel 2 BDA (50-146605)

See section 4.2.7

4.2.8.1 UHF Duplex Channel 2 BDA System Diagram, Drg. # 50-146685

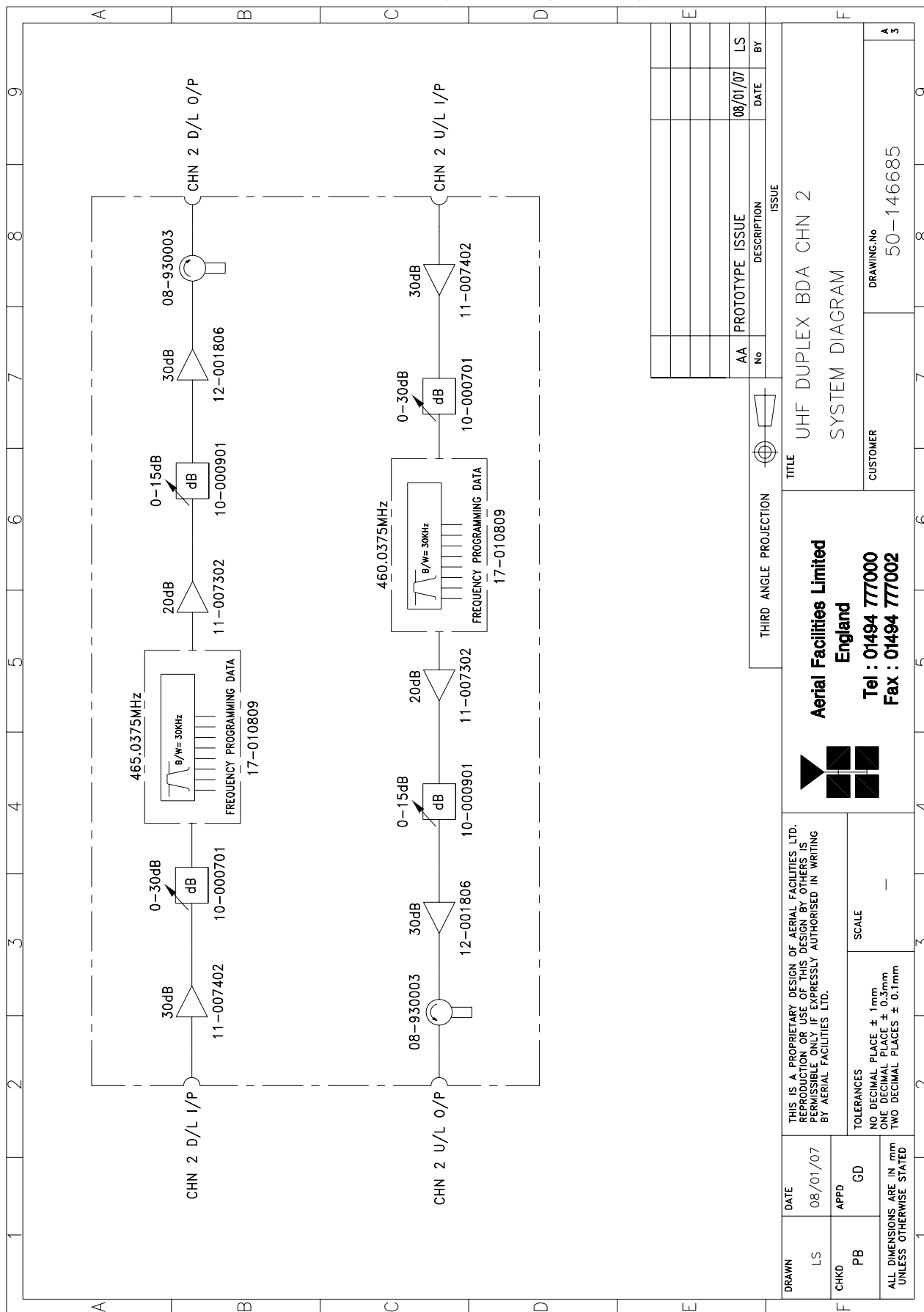

4.2.9 UHF Duplex Channel 3 BDA (50-146606)

See section 4.2.7

4.2.9.1 UHF Duplex Channel 3 BDA System Diagram, Drg. # 50-146686

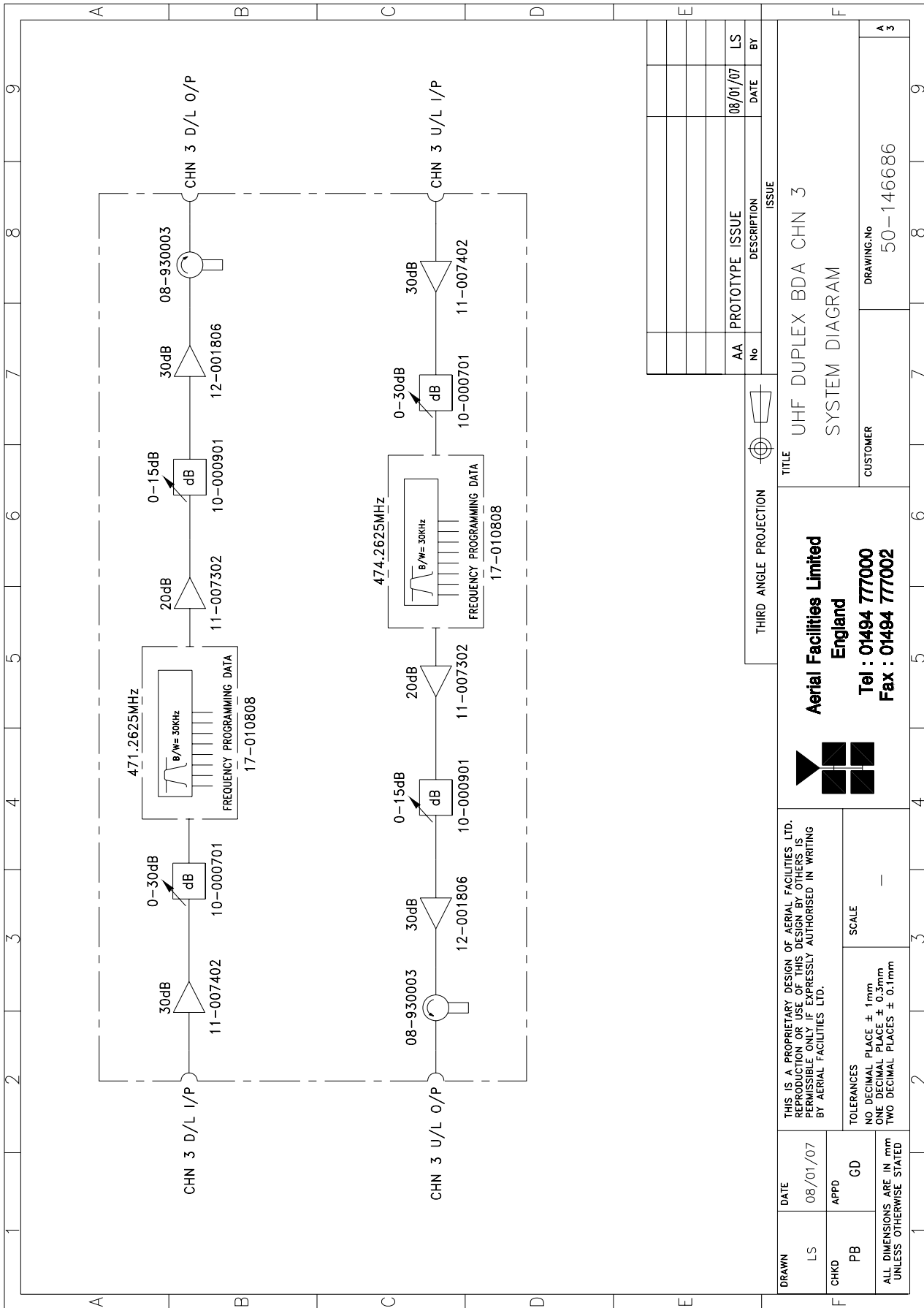

4.2.10 UHF Duplex Channel 4 BDA (50-146607)

See section 4.2.7

4.2.10.1 UHF Duplex BDA Channel 4 System Diagram, Drg. # 50-146687

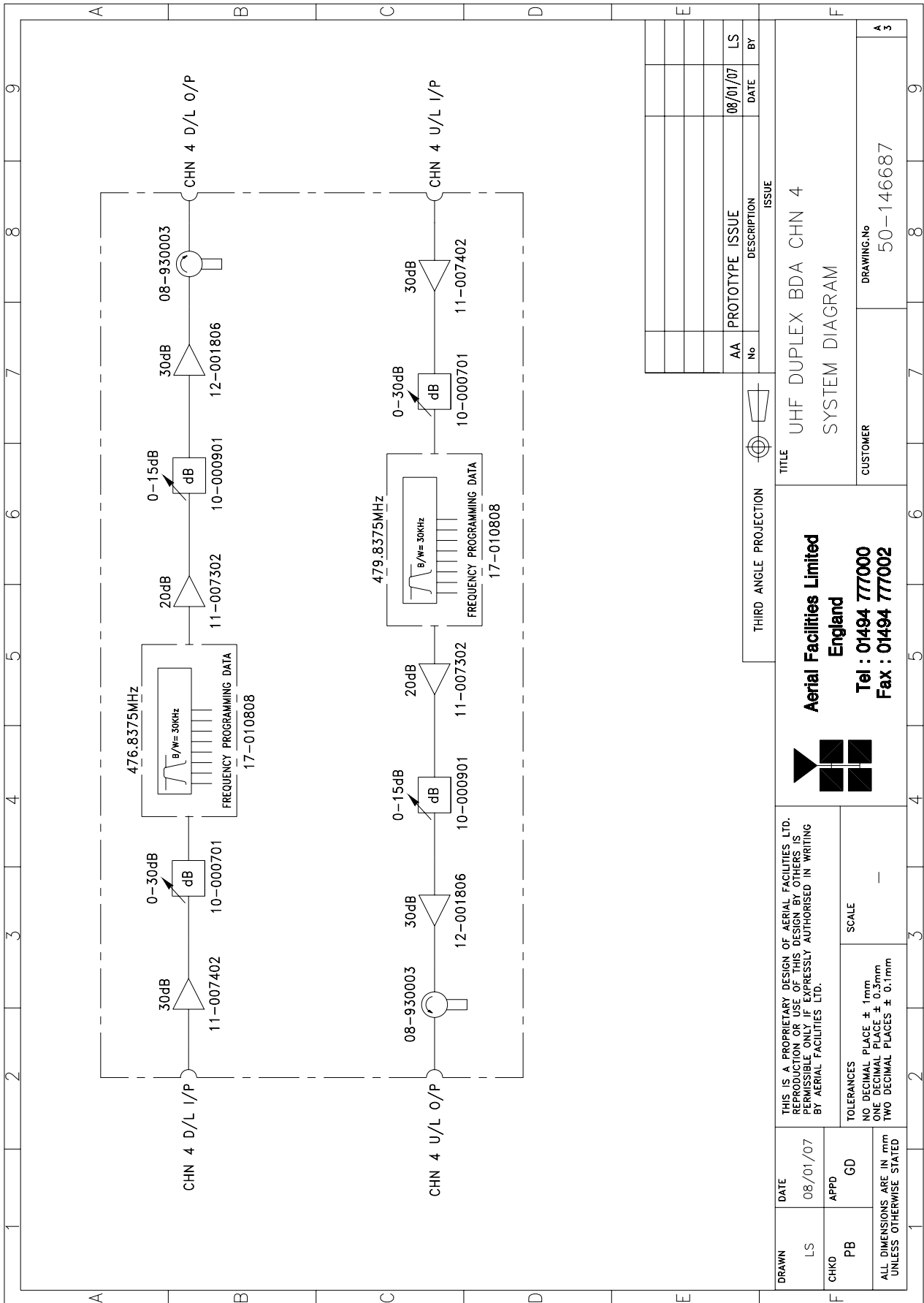

4.2.11 UHF Duplex Channel 5 BDA (50-146608)

See section 4.2.7

4.2.11.1 UHF Duplex Channel 5 System Diagram, Drg. # 50-146688

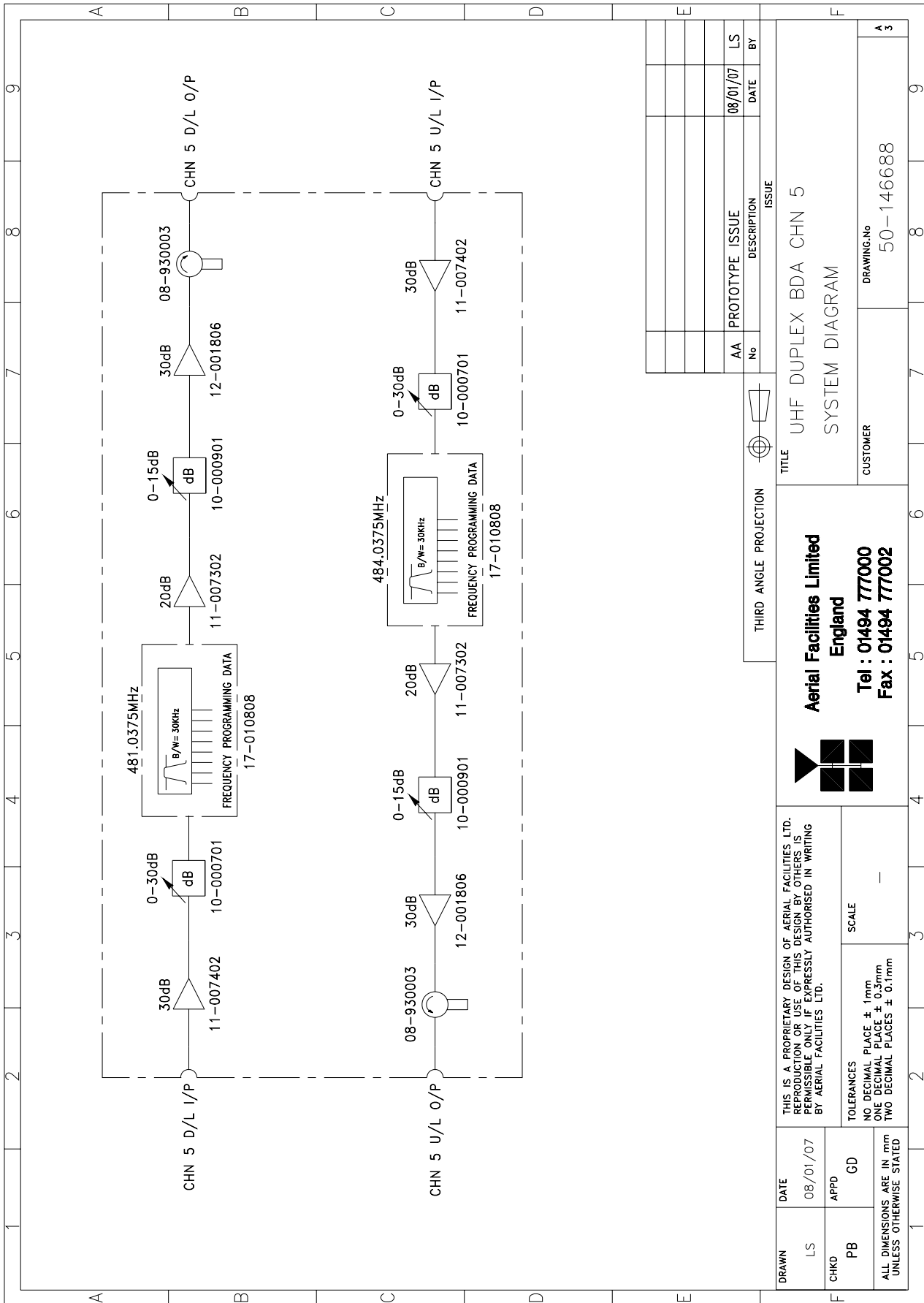

4.2.12 UHF Duplex Channel 6 BDA (50-146612)

See section 4.2.7

4.2.12.1 UHF Duplex Channel 6 BDA System Diagram, Drg. # 50-146692

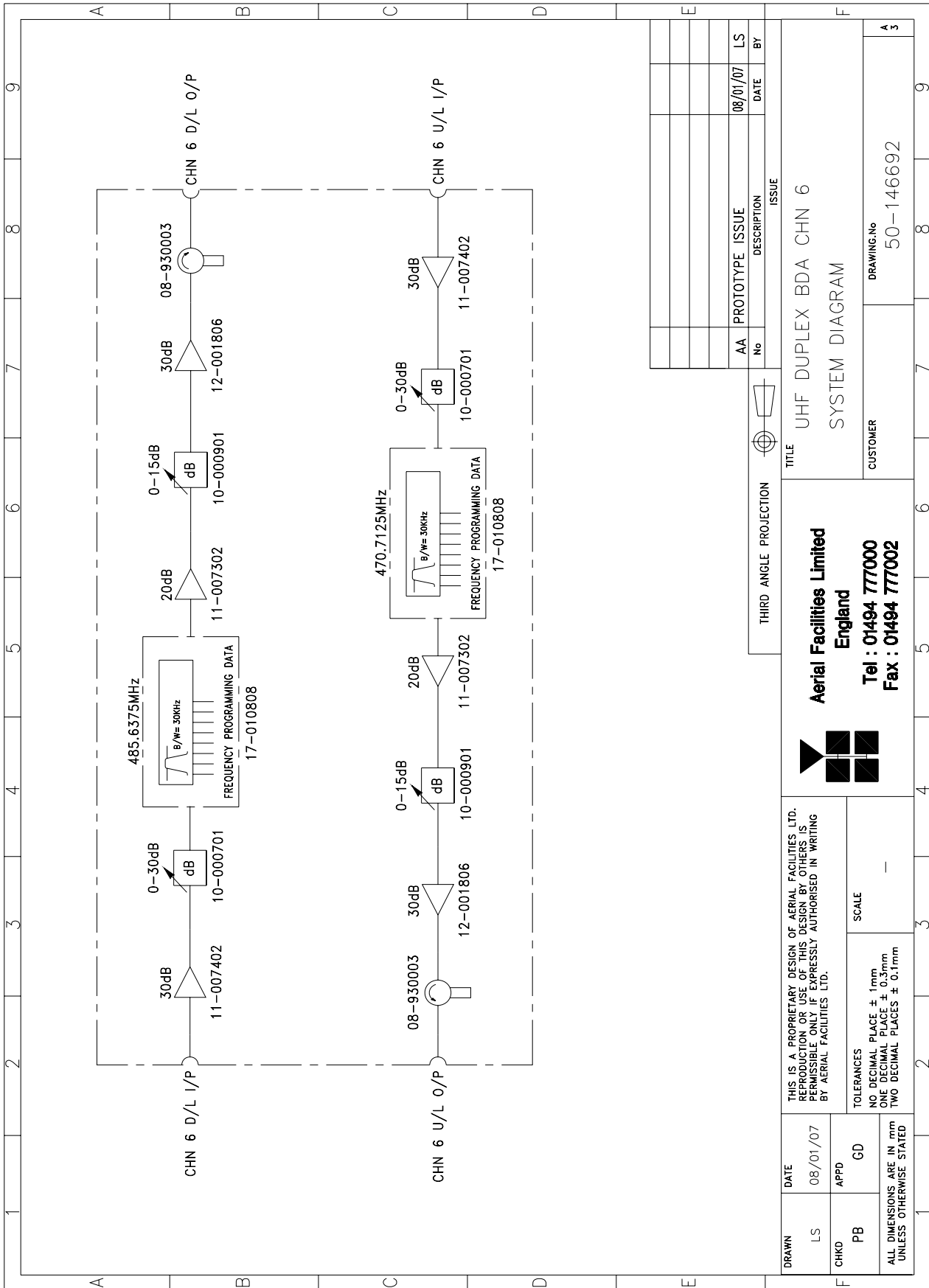

4.2.13 UHF Uplink Combiner Shelf (50-146609)

4.2.13.P UHF Uplink Combiner Shelf Photographs

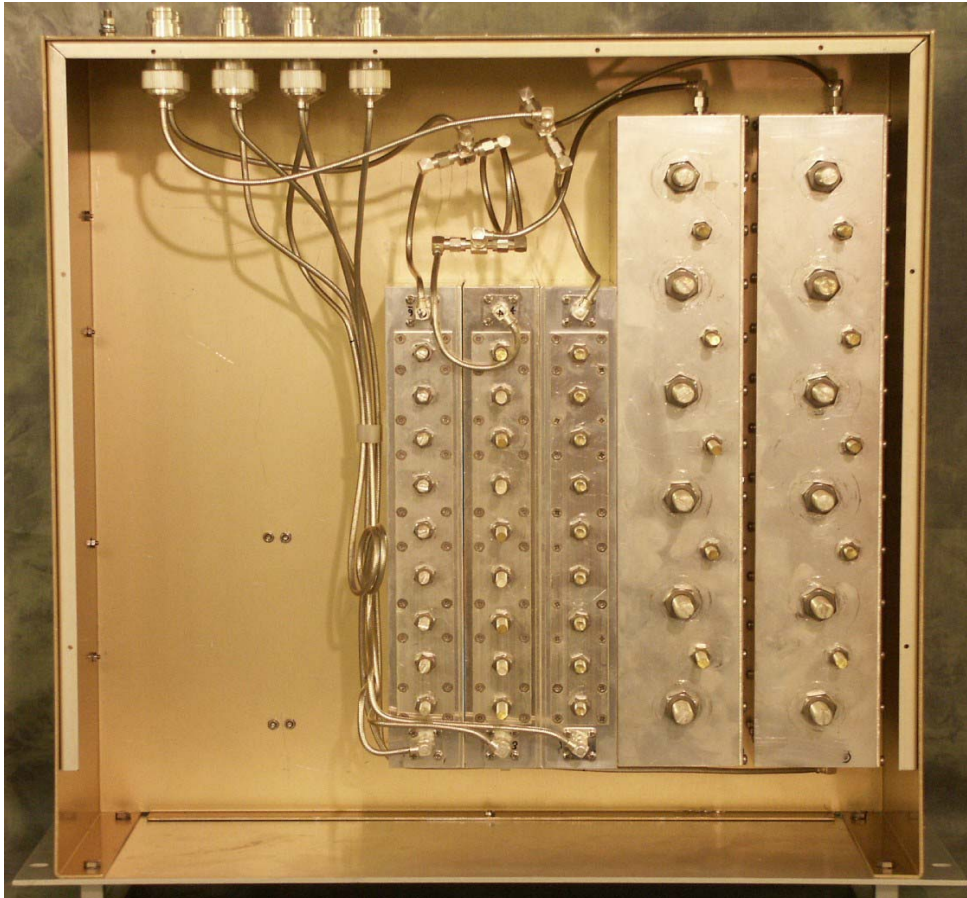

4.2.13.1 Description

This uplink combiner receives all the UHF signals from the different duplex cell enhancer shelves and couples them together using a combination of bandpass filters and hybrids to the single Tx antenna. This is a passive only shelf and has no need of a power supply or alarms.

4.2.13.2 Technical Specification

PARAMETER		SPECIFICATION
Shelf dimensions:	Height:	4U
	Width:	19" (482.6mm)
	Depth:	<450mm (excluding connectors & handles)
Temperature range:	operational:	-20°C to +60°C
	storage:	-40°C to +70°C
	Weight:	<10kg
	Impedance:	50Ω
	Humidity:	5 – 95% non-condensing
	RF Connectors:	N type female
	Environmental protection:	IP44
Finish:	Case:	Iridite NCP coating
	Heatsinks:	None
	Handles:	Silver anodised aluminium alloy
	Fascia	Painted to RAL7035

4.2.13.3 Parts List

AFL Part Nō.	Part Description	Qty.
02-007302	SDF C/L5P VAR.BW TOP SMA 40 mm POST	1
02-007309	SDF C/L5P VAR.BW TOP SMA 50mm POST	1
02-013401	6P CL FLTR(0.5 min BW) LARGE SMA ASSY	2
02-020001	UHF 2 LN NOTCH FILTER SMA	1
05-000104	TRANS.HYBRD.COUPL.3 PORT 50W INT.L	2
19-001022K	4U CHASSIS KIT (450mm deep)	1
91-030002	N ADAPTOR PANEL FEMALE:FEMALE	7
91-130001	SMA ADAPT 'T' ALL FEMALE 3 GHz	3

4.2.13.4 UHF Uplink Combiner Shelf System Diagram, Drg. # 50-146689

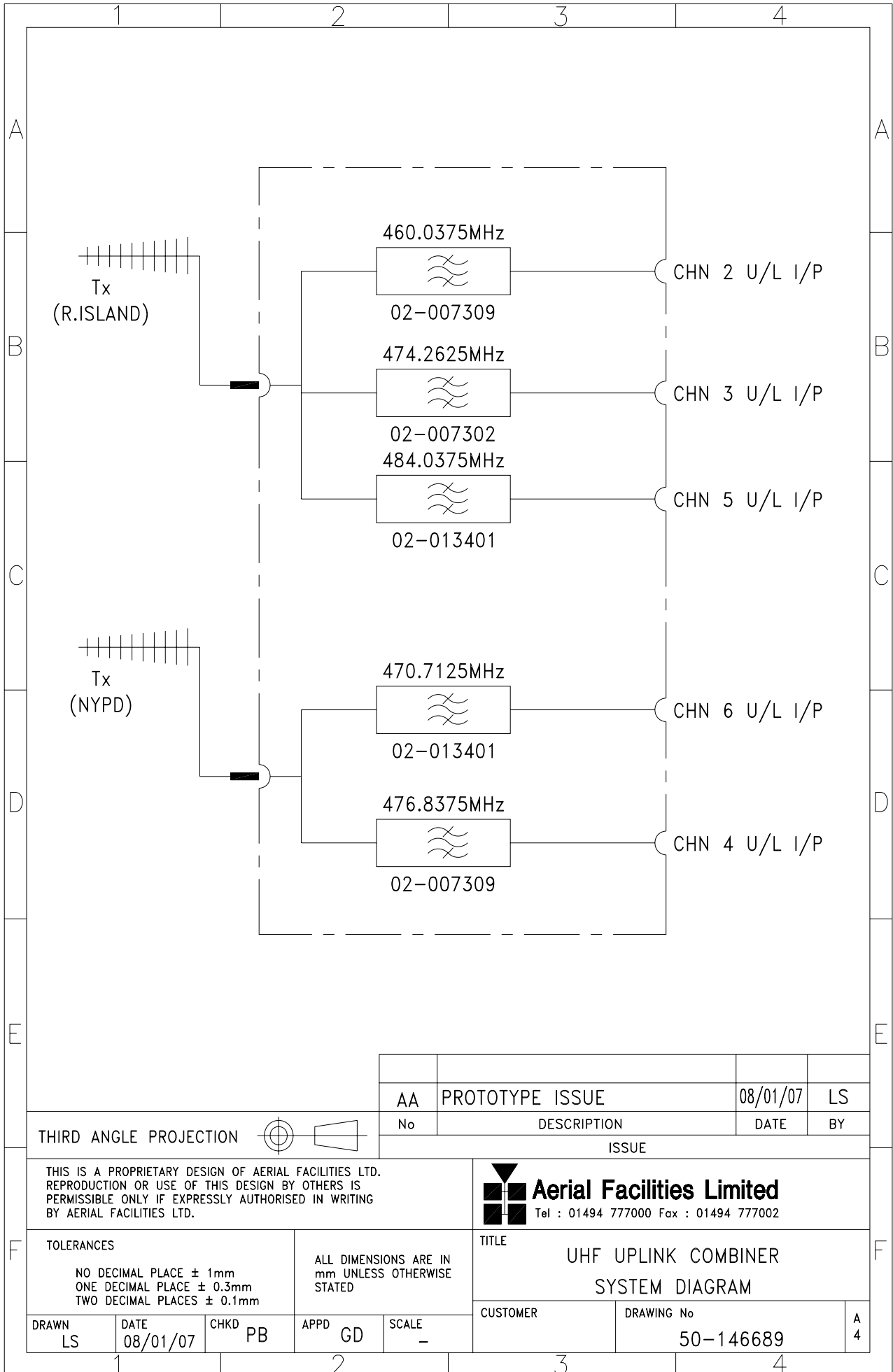

AA	PROTOTYPE ISSUE	08/01/07	LS
No	DESCRIPTION	DATE	BY
ISSUE			

THIRD ANGLE PROJECTION

THIS IS A PROPRIETARY DESIGN OF AERIAL FACILITIES LTD.
REPRODUCTION OR USE OF THIS DESIGN BY OTHERS IS
PERMISSIBLE ONLY IF EXPRESSLY AUTHORISED IN WRITING
BY AERIAL FACILITIES LTD.

Aerial Facilities Limited
Tel : 01494 777000 Fax : 01494 777002

TOLERANCES
NO DECIMAL PLACE ± 1mm
ONE DECIMAL PLACE ± 0.3mm
TWO DECIMAL PLACES ± 0.1mm

ALL DIMENSIONS ARE IN
mm UNLESS OTHERWISE
STATED

TITLE
UHF UPLINK COMBINER
SYSTEM DIAGRAM

DRAWN LS	DATE 08/01/07	CHKD PB	APPD GD	SCALE -	CUSTOMER	DRAWING No 50-146689	A 4
-------------	------------------	------------	------------	------------	----------	-------------------------	--------

4.2.14 UHF Downlink Splitter Shelf (50-146610)

4.2.14.P UHF Downlink Splitter Shelf Photographs

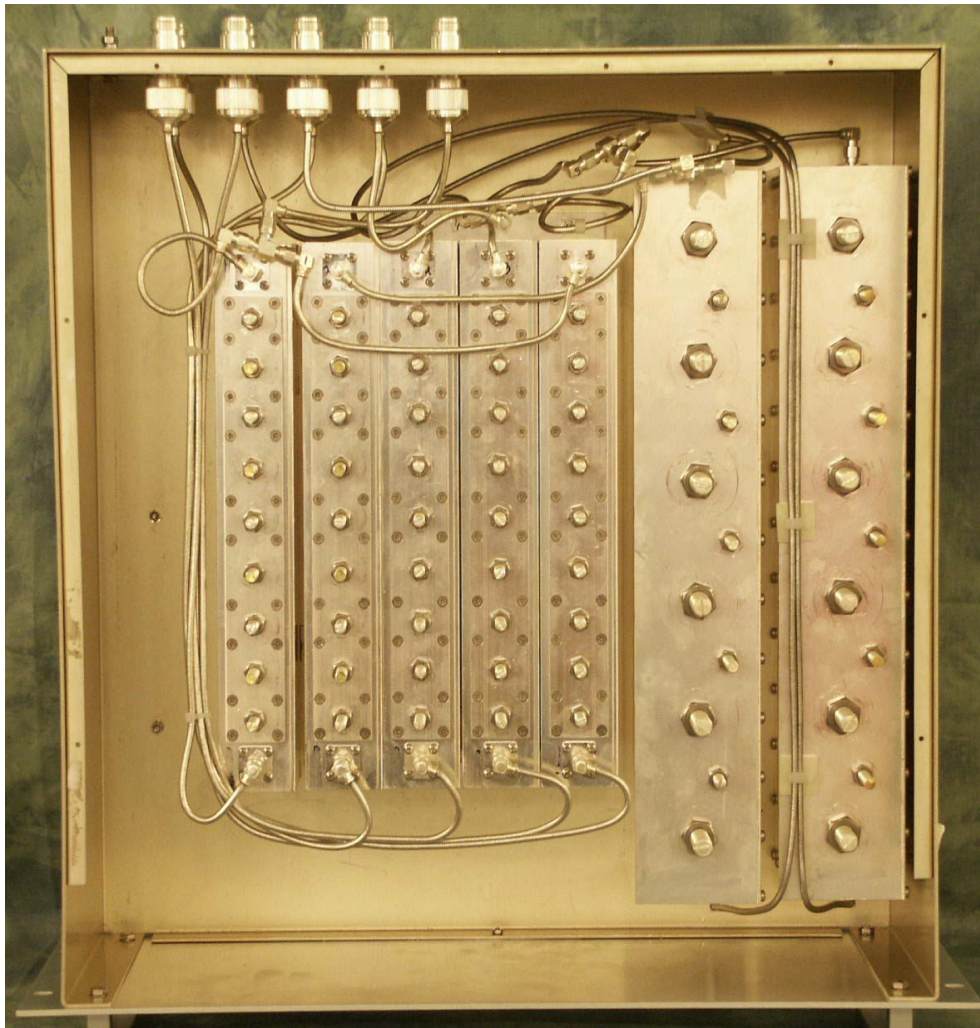

4.2.14.1 Description

This UHF downlink splitter shelf couples the received UHF signals to the cell enhancers via bandpass filters and hybrids. This passive shelf has no connection to any power supply and no alarms.

4.2.14.2 Technical Specification

PARAMETER		SPECIFICATION
Shelf dimensions:	Height:	4U
	Width:	19" (482.6mm)
	Depth:	<450mm (excluding connectors & handles)
Temperature range:	operational:	-20°C to +60°C
	storage:	-40°C to +70°C
	Weight:	<10kg
	Impedance:	50Ω
	Humidity:	5 – 95% non-condensing
	RF Connectors:	N type female
	Environmental protection:	IP44
Finish:	Case:	Alocrom 1200/Iridite NCP coating
	Heatsinks:	None
	Handles:	Anodised aluminium alloy
	Fascia	Painted to RAL7035

4.2.14.3 Parts List

AFL Part Nō.	Part Description	Qty.
02-007309	SDF C/L5P VAR.BW TOP SMA 50mm POST	3
02-013401	6P CL FLTR (0.5 min BW)LARGE SMA ASSY	2
02-020001	UHF 2 LN NOTCH FILTER SMA	2
05-002603	UHF 3dB SPLITTER SMA	1
19-001022K	4U CHASSIS KIT (450mm deep)	1
91-030002	N ADAPTOR PANEL FEMALE:FEMALE	7
91-130001	SMA ADAPT 'T' ALL FEMALE 3 GHz	4

4.2.14.4 UHF Downlink Splitter Shelf System Diagram, Drg. # 50-146690

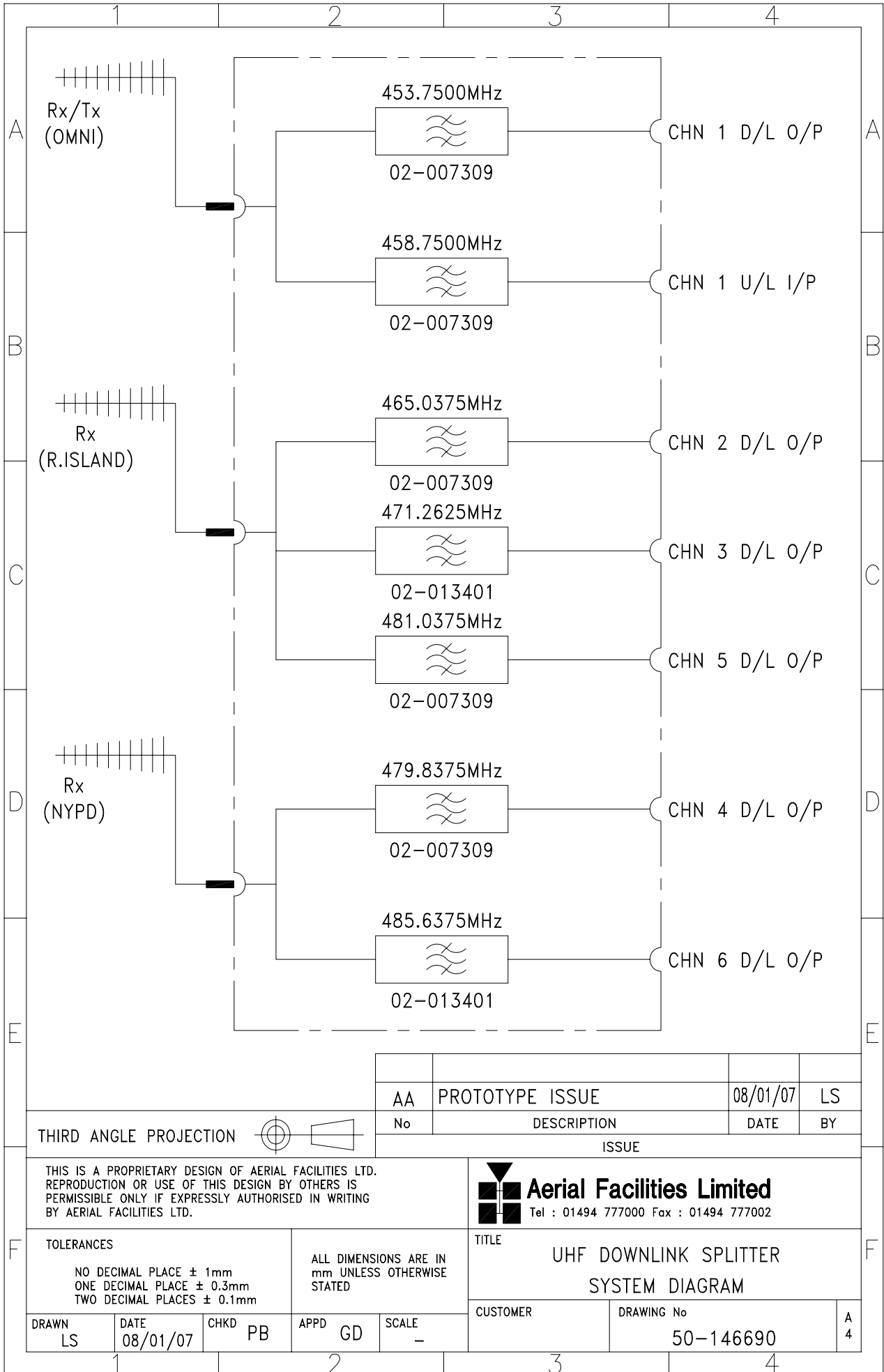

AA	PROTOTYPE ISSUE	08/01/07	LS
No	DESCRIPTION	DATE	BY
ISSUE			

THIRD ANGLE PROJECTION

THIS IS A PROPRIETARY DESIGN OF AERIAL FACILITIES LTD. REPRODUCTION OR USE OF THIS DESIGN BY OTHERS IS PERMISSIBLE ONLY IF EXPRESSLY AUTHORISED IN WRITING BY AERIAL FACILITIES LTD.

Aerial Facilities Limited
 Tel : 01494 777000 Fax : 01494 777002

TOLERANCES		ALL DIMENSIONS ARE IN mm UNLESS OTHERWISE STATED	
NO DECIMAL PLACE ± 1mm ONE DECIMAL PLACE ± 0.3mm TWO DECIMAL PLACES ± 0.1mm			
DRAWN LS	DATE 08/01/07	CHKD PB	APPD GD
SCALE -			

TITLE UHF DOWNLINK SPLITTER SYSTEM DIAGRAM		
CUSTOMER	DRAWING No 50-146690	A 4

4.3 800MHz Channel Selective Cell Enhancer Rack (50-146701)

4.3.1 Description

The 800MHz cell enhancer consists of four dedicated shelves and features two, separate, IF channels tuned by independent channel selective modules (one 5.0MHz B/W, one 3.0MHz). The power supply shelf provides all the DC needed by the whole 800MHz system, driven from the local mains supplies. Alarms are provided from each active device and all are 'looped' to form a normally closed fail-safe alarm (locally for each shelf and globally for the whole enhancer/rack). This loop alarm is easily configured to join any other similarly wired system. Operators should be aware that the 8U BDA shelf and the 100W amplifier shelf are at the weight limit for a one-person lift. ***If in doubt do not attempt to lift these shelves alone!***

No battery backup is provided for this system, should the mains supply fail, the 800MHz system will not function.

4.3.2 Technical Specification

PARAMETER		SPECIFICATION
Rack	Height:	43U Standard Eldon Vented Rack
	Width:	19" (482.6mm)
	Depth:	600mm
Shelves:	Height:	See parts lists
	Width:	19" (482.6mm)
	Depth:	<450mm (excluding heatsinks, connectors, handles and feet)
Temperature range:	operational:	-20°C to +60°C
	storage:	-40°C to +70°C
	Weight:	>100kg
	Humidity:	5 – 95% non-condensing
	RF Connectors:	N type female
	Environmental protection:	IP44
	Supply cable:	All shelves supplied from dedicated PSU shelf
* Note: Individual shelf weights not specified.		

4.3.3 Parts List

AFL Part Nō.	Part Description	Qty.
50-146702	800MHz CHN SELECT UL AND DL TRAY	1
50-146703	800MHz CHN SELECT POWER AMPLIFIER	1
50-146704	800MHz CHANNEL SELECTIVE PSU	1
80-054020	600mm DEEP SUPPORT BRACKET	8
80-063654	1U BLANKING PANEL (BS) RAL 7035	1
80-063655	2U BLANKING PANEL (BS) RAL 7035	3
90-100011	IEC MAINS LEAD '6 AMP' for USA	1
91-000002	N PLUG RG223:U	14
91-030002	N ADAPTOR PANEL FEMALE:FEMALE	7
97-500175	ELDON 43U 600 x 600 RACK (VENTED LID)	1
99-000082	PALLET 900 x 900 x 7ply FOR RACKS	1

4.3.4 800MHz Channel Selective C.E. System Diagram, Drg. # 50-146782

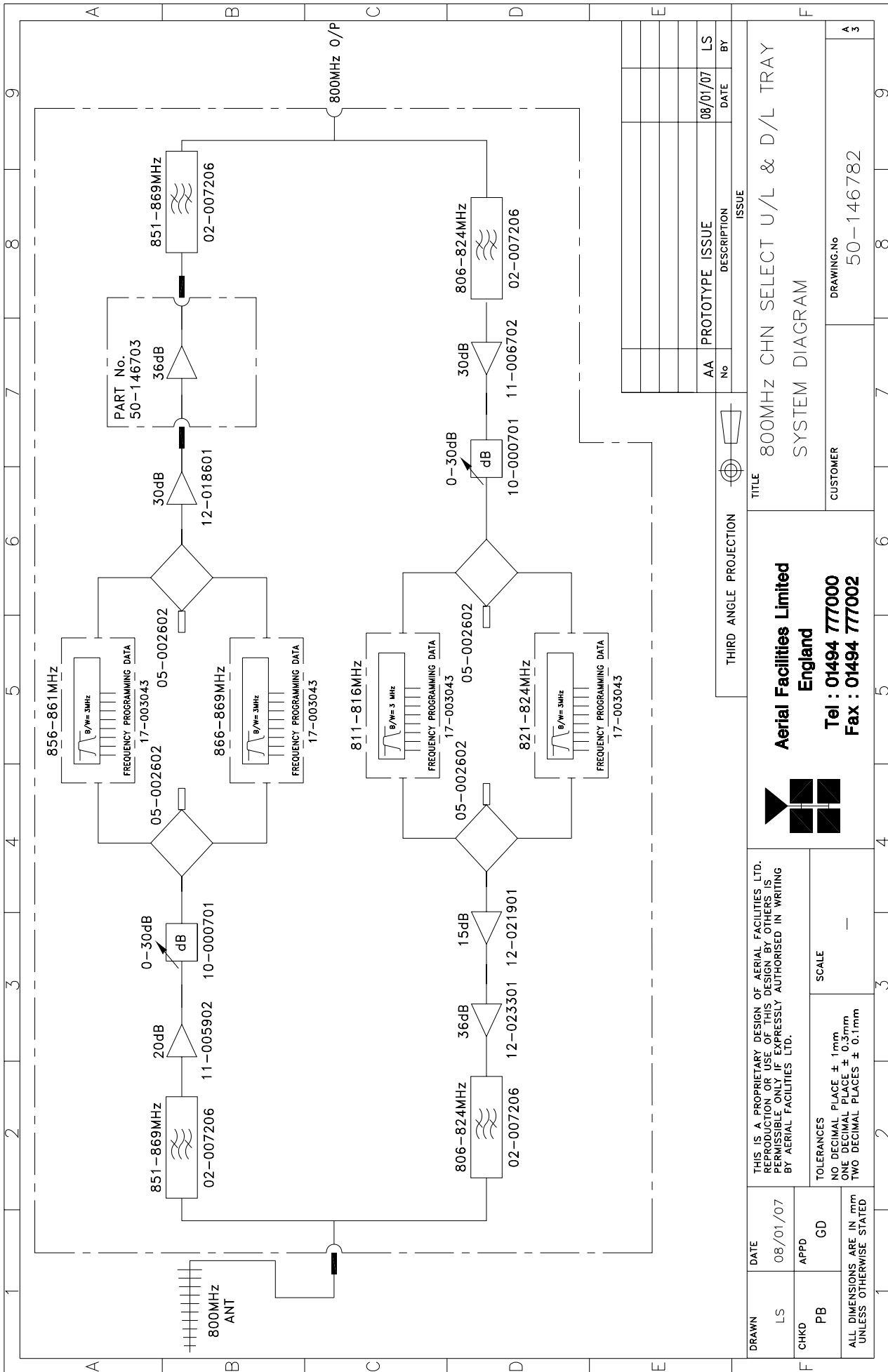

4.4 Channel Selective Uplink & Downlink Shelf (50-146702)

4.4.P Uplink & Downlink Shelf Photographs

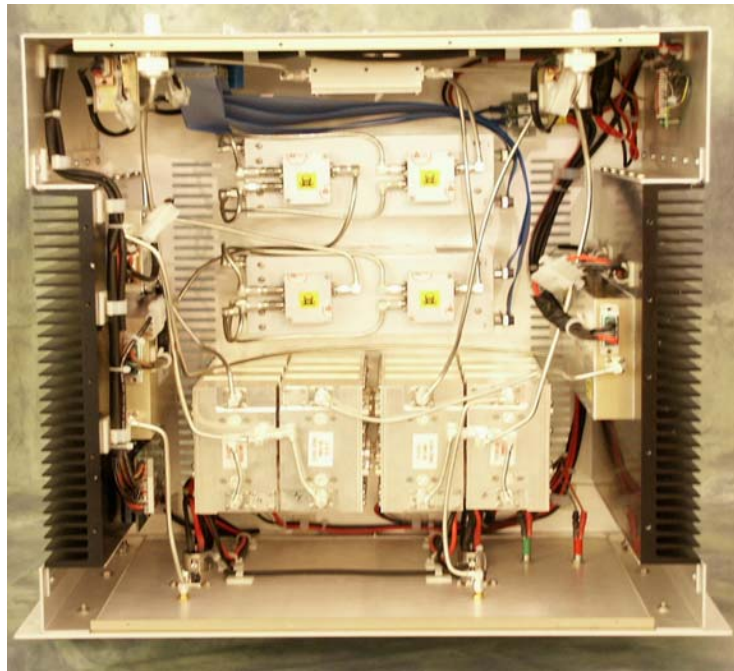

4.4.1 Uplink & Downlink Shelf Description

This 8U shelf holds all the electronics modules for the 800MHz BDA except for the downlink power amplifier shelf and the PSU shelf. The alarms are a volt-free, relay contact pair, 'D' connector pins 1 & 2.

4.4.2 Uplink & Downlink Shelf Electrical Specifications

PARAMETER	SPECIFICATION
800MHz tuned frequency ranges:	851-869 MHz (downlink) 806-824 MHz (uplink)
IF Band select downlink channels:	856-861MHz 866-869MHz
IF Band select uplink channels:	811-816MHz 821-824MHz
IF Bandwidths:	3MHz or 5MHz
Gain Adjustment:	0 - 30dB (in 2dB steps)
Uplink Power:	>10Watts
Downlink Power:	>80-100Watts
AGC:	Fitted in all channel selective modules
Noise Figure:	<6dB (@ maximum gain)
VSWR:	better than 1.5:1
Impedance:	50Ω
RF Connectors:	N type, female
Alarms Fitted: (‘D’ connector, pins 1 & 2)	1 Amplifiers

4.4.3 Uplink & Downlink Shelf Mechanical Specifications

PARAMETER	SPECIFICATION
Shelf:	Height: 8U
	Width: 19" (482.6mm)
	Depth: <450mm(excluding heatsinks, connectors, handles and feet)
Temperature range:	operational: -20°C to +60°C
	storage: -40°C to +70°C
Weight:	<20kg
Humidity:	5 – 95% non-condensing
RF Connectors:	N type female
Environmental protection:	IP44

4.4.4 Uplink & Downlink Shelf System Diagram See section 4.3.4

4.4.5 Uplink & Downlink Shelf Parts List

AFL Part Nō.	Part Description	Qty.
02-007206	900MHz 8POLE 15-25MHz B/W "SMA"	4
05-002603	UHF 3dB SPLITTER SMA	4
10-000701	1/4W0-30dB SWITCHED ATTENUATOR	2
11-005902	900MHz LOW NOISE AMP WITH RELAY ASS	1
11-006702	GA 800-1000MHz LNA 29dB (WITH RELAY)	1
12-018601	POWER AMPLIFIER 900MHz 5W	1
12-021901	POWER AMPLIFIER 900MHz 1W +12V	1
12-023301	PA 851-866MHz 20W LINEARIZED +24V	1
13-003011	DC/DC CONVERTER 24-12V 8A PCB SUB-ASS	1
14-000225	CASE RAIL LONG R.S.A./R.F.A.	2
17-002101	CHANNEL CONTROL MODULE	1
17-002103	26WAY RIBBON CABLE LEAD	4
17-003043	CHAN MOD 820-870MHz 3.0MHz B/W	4
17-004730	ATTENUATOR MOUNTING	2
17-004733	SIMP.C.E ATTENUATOR COVER(RAL7032)	2
50-012820	CCE RACK MOUNTED 8U CHASSIS	1
50-012822	CCE RACK MOUNTED LID	1
50-012825	CCE RACK MOUNTED HEATSINK BRACKET	4
50-027720	RACK MTD CHAN C.E. MODIFIED HEATSIN	2
80-008901	12V RELAY PCB ASSEMBLY **NO LED**	1
80-090822	C/E 8U FRONT PANEL, AFL (RAL7035)	1
91-030002	N ADAPTOR PANEL FEMALE:FEMALE	2
91-130001	SMA ADAPT 'T' ALL FEMALE 3 GHz	2
91-130005	SMA BULKHEAD ADAPTOR F/F	2
91-500001	POWER PLG 3 PIN PNL.MOUNT NC-X	1
91-510002	3 PIN STRAIGHT FREE SOC.NC-X.	1
91-510032	20A SOCKET CONTACT PIN	2
91-600005	'D' 9 WAY SOCKET S/B TERM	2
91-600014	'D' 9 WAY SOCKET S/B (NON FILTERED)	6
91-600015	'D' 9 WAY PLUG S/B (NON FILTERED)	3
91-660001	2W5 MIXED D TYPE SOCKET (7 WAY)	1
91-700017	ICD 15 WAY 0.1' CONNECTOR	1
96-600003	INSULATING BOOT D.C.	1
96-700034	LED RED 5mm IP67 INTEGRAL RES. 24V	1
96-700035	LED GREEN 5mm IP67 INTEGRAL RES 24V	1
97-400005	HANDLE TYPE H6802 3U [ALLOY]	2

4.5 800MHz Downlink Power Amplifier Shelf (50-146703)

4.5.P Downlink Power Amplifier Shelf Photographs

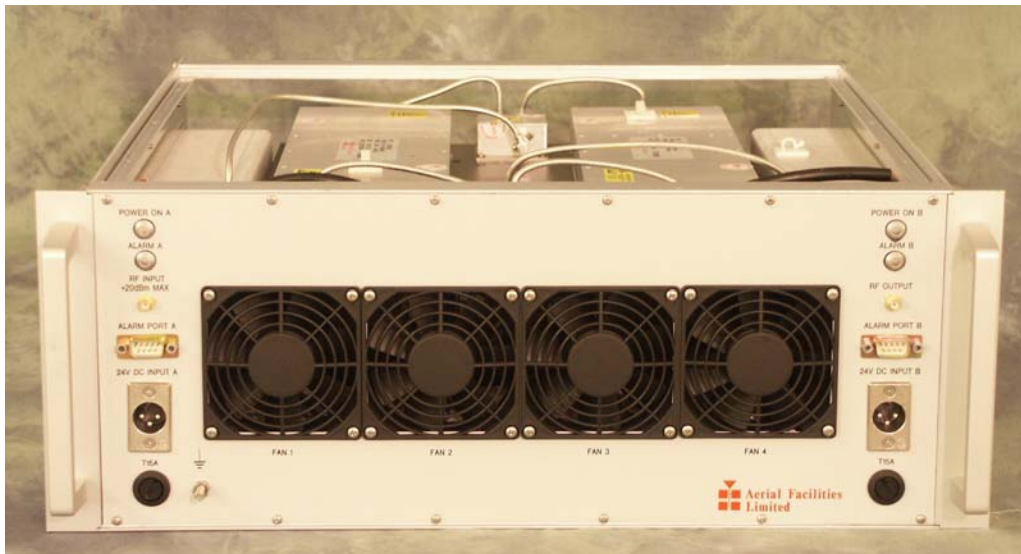
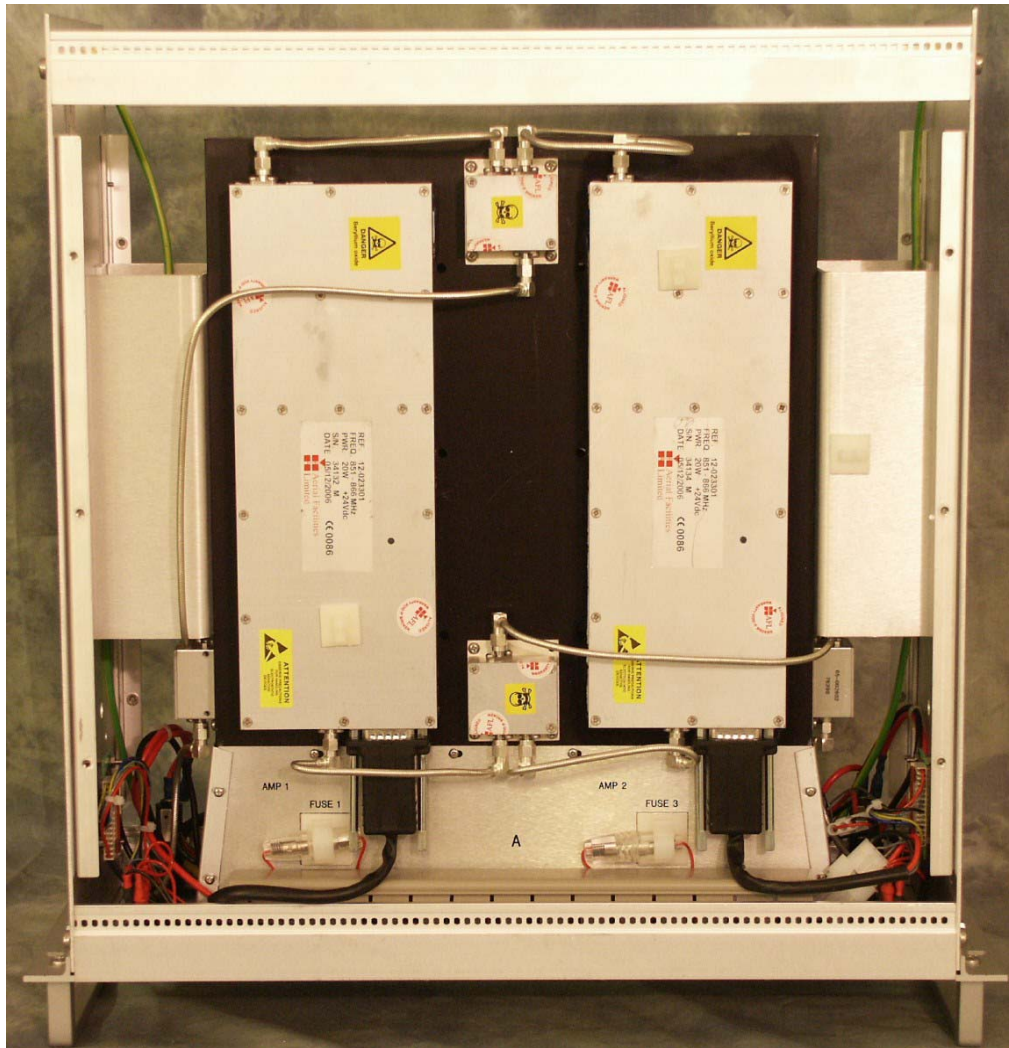

4.5.1 Downlink Power Amplifier Shelf Description

The 100W amplifier shelf is a linearised Class A amplifier where 4 linearised power amplifiers are combined together in a series/parallel configuration which yields approximately double the output power per path. Its housing is a 4U 19" Rack with SMA connectors for the RF input/output, 2 D-Type connectors for the alarm function and 2 DC connectors with fuse for the 24 DC supply. Its cooling is realized by fans mounted on the front panel.

It has a built in Current Fault Alarm Function with the four amplifiers in two summary alarm paths. The summary alarm on D connector 'A' will show an alarm for the two amplifiers mounted on the top of the shelf. The summary alarm on D connector 'B' will show an alarm for the two amplifiers mounted at the bottom of the shelf.

4.5.2 Downlink Power Amplifier Shelf Electrical Specifications

PARAMETER	SPECIFICATION
Frequency range:	851-866MHz
Bandwidth:	<30MHz
Gain:	36dB (typical)
Gain Flatness:	<0.5dB
1dB Compression Point:	+43.5dBm (typical)
3rd order intercept:	+61.5dBm (typical)
Input/Output return loss:	>15dB
Connectors:	SMA female
Supply:	24V DC @ 16-18Amps
Alarms:	'D' conn. Pins 1 & 2 (x2)

4.5.3 Downlink Power Amplifier Shelf Mechanical Specification

PARAMETER	SPECIFICATION	
Shelf:	Height:	4U
	Width:	19" (482.6mm)
	Depth:	<450mm(excluding heatsinks, connectors, handles and feet)
Temperature range:	operational:	-20°C to +60°C
	storage:	-40°C to +70°C
	Weight:	<25kg
	Humidity:	5 – 95% non-condensing
	RF Connectors:	N type female
	Environmental protection:	IP44

4.5.4 Downlink Power Amplifier Shelf System Diagram

See section 4.3.4

4.5.5 Downlink Power Amplifier Shelf Parts List

AFL Part Nö.	Part Description	Qty.
05-002602	900MHz SPLITTER/COMBINER, 20W	6
05-002622	SPLITTER/COMBINER AUX. MTG PLATE	6
12-023301	PA 851-866MHz 20W LINEARIZED +24V	4
80-008902	24V RELAY PCB ASSEMBLY **NO LED**	2
80-245121	CLASS A LINEARIZED HEATSINK	2
80-245122	100WTETRA LINEARIZED H'SINK MTG BKT	2
80-245123	100WTETRA LINEARIZED SIDE PANEL	2
80-245124	100WTETRA LINEARIZED RACK LID	2
80-245125	100WTETRA LINEARIZED FRONT PANEL	1
80-245126	100WTETRA LINEARIZED DUCT END PLATE	2
80-245128	100WTETRA LINEARIZED DUCT MTG BLOCK	4
80-245129	100WTETRA LINEARIZED LID MTG BKT	4
80-245130	100WTETRA LINEARIZED DUCT TOP COVER	1
80-245131	100WTETRA LINEARIZED DUCT BOT COVER	1
80-245132	CLASS A LINEARIZED AMP CABLE TIDY	2
90-010021	RF CABLE SUPFLEX SMA R/A MALE 100mm	4
90-010024	RF CABLE SUPFLEX SMA R/A MALE 400mm	2
90-010026	RF CABLE SUPFLEX SMA R/A MALE 150mm	6
90-010027	RF CABLE SUPFLEX SMA R/A MALE 250mm	2
91-130005	SMA BULKHEAD ADAPTOR F/F	2
91-500001	POWER PLG 3 PIN PNL.MOUNT NC-X	2
91-600015	'D' 9 WAY PLUG S/B (NON FILTERED)	2
91-600019	'D'15 WAY SHELL (2W7)	4
91-640004	LARGE PIN FOR 91-660001 D SOCKET	8
91-660001	2W5 MIXED D TYPE SOCKET (7 WAY)	4
91-700017	ICD 15 WAY 0.1' CONNECTOR	2
91-700036	MISC 3 WAY PLUG HOUSING	4
91-700037	MISC 4 WAY PLUG HOUSING	2
91-700038	MISC PLG PIN FOR 3WAY HOUSING 14AWG	32
91-700039	MISC 3 WAY SOCKET HOUSING	6
91-700040	MISC 4 WAY SOCKET HOUSING	2
91-700042	MISC SOC.PIN FOR 3WAY HOUSING 14AWG	12
92-110003	CABLE CLIPS LARGE 13mm (WHITE)	0
92-300010	M3 x 12 HEX SPACER BRASS N:P	4
92-340001	M3 x 8mm 'D'CONNECTOR SCREW LOCK	12
92-700008	M3 BLUE RING TERMINAL %	4
92-700010	M5 BLUE RING TERMINAL	2
92-700057	FEM 2.8 x 0.8 PUSH ON BARE TERM RED	8
96-100004	32mm 20A (16A max load) FUSE HOLDER	2
96-110005	315mA FUSE GLASS A/SURGE 20 x 5mm	4
96-110015	T 15A A/SURGE FUSE 1.25'	2
96-110040	BULGIN IN-LINE FUSEHOLDER 20mm	4
96-400002	80 x 80mm 24V DC FAN SUNON	4
96-400003	PLASTIC FINGER GUARD 80 x 80mm	4
96-600003	INSULATING BOOT D.C.	2
96-700034	LED RED 5mm IP67 INTEGRAL RES. 24V	2
96-700035	LED GREEN 5mm IP67 INTEGRAL RES 24V	2
97-400002	HANDLE TYPE H6803 4U.[ALLOY]	2
97-600004	19" SUBRACK REAR RAIL	2
97-600005	19" SUBRACK FRONT RAIL	2
97-600008	19" SUBRACK TAPPED STRIP	2
97-600016	19" 4U SUBRACK MOUNTING FLANGE	2

4.6 Multiband Combiner Shelf (50-146705)

4.6.P Multiband Combiner Shelf Photographs

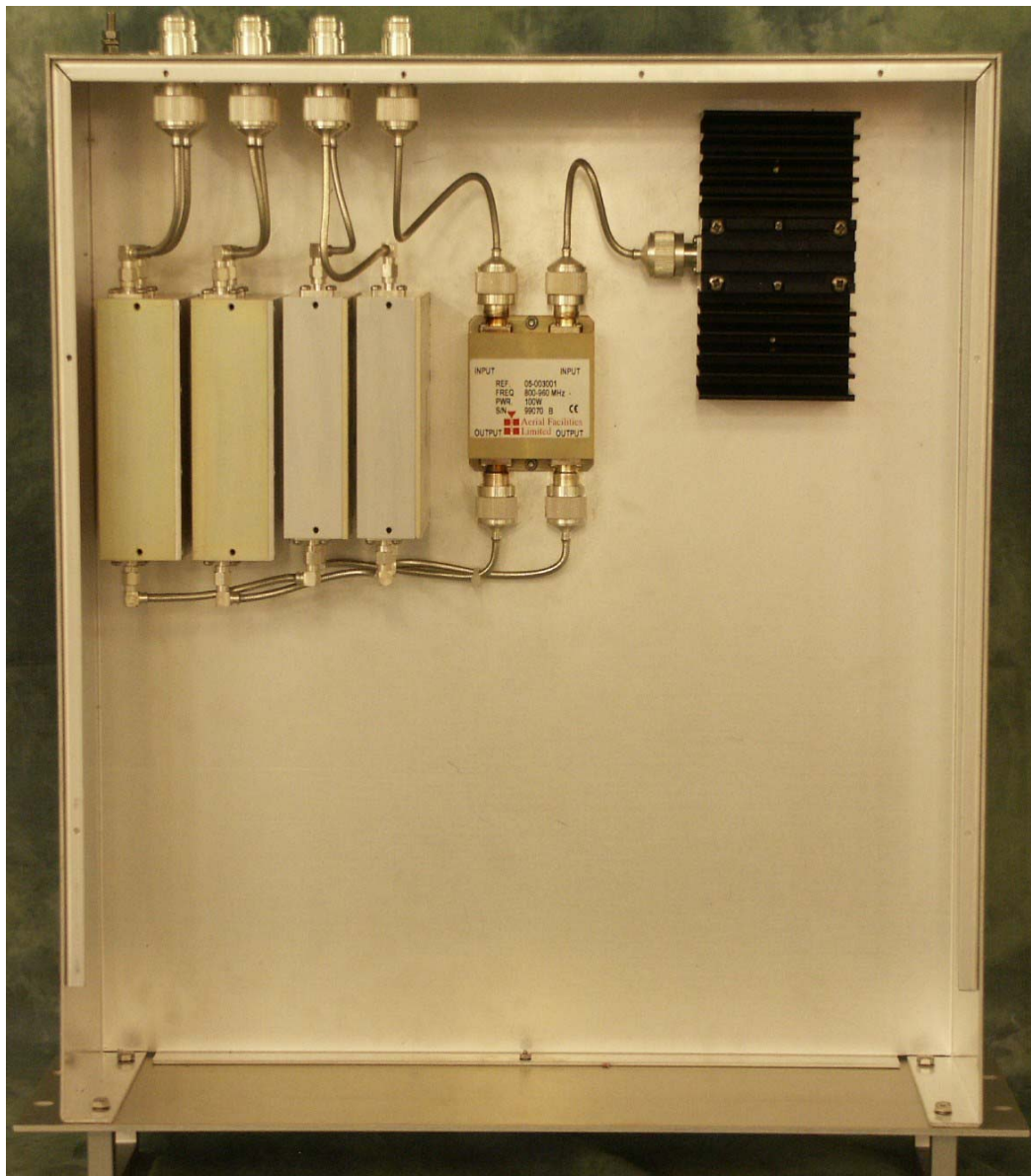

4.6.1 Multiband Combiner Shelf Description

The multiband combiner performs the task of receiving all three frequency bands (VHF, UHF & 800MHz), passing them through a series of crossband couplers and a hybrid combiner to the two exit ports, DAS1 & DAS2. This is an entirely passive unit using no active devices, no power supply and therefore no alarm interface.

4.6.2 Multiband Combiner Shelf Technical Specification

PARAMETER		SPECIFICATION	
VHF Frequencies:		153.965MHz* (Ch 1)	VHF downlink
		154.755MHz	
		154.785MHz	
		154.980MHz	
		158.925MHz* (Ch 2)	VHF uplink
		151.355MHz* (Ch 1)	
		154.6575MHz* (Ch 2)	
		154.755MHz	
		154.785MHz	
		154.980MHz	
UHF Frequencies:		453.7500MHz	UHF downlink
		465.0375 MHz	
		471.2625 MHz	
		479.8375 MHz	
		481.0375 MHz	
		485.6375 MHz	UHF uplink
		458.7500 MHz	
		460.0375 MHz	
		470.7125 MHz	
		474.2625 MHz	
800MHz tuned frequency ranges:		851-869 MHz	(downlink)
		806-824 MHz	(uplink)
VSWR:		better than 1.5:1	
Impedance:		50Ω	
RF Connectors:		N type, female	
Alarms Fitted:		None	
Environmental protection:		IP44	
Weight:		<10kg	
Shelf:	Height:	3U	
	Width:	19" (482.6mm)	
	Depth:	<450mm(excluding heatsinks, connectors, handles and feet)	
Temperature range:	operational:	-20°C to +60°C	
	storage:	-40°C to +70°C	

* = Duplex channel

4.6.3 Multiband Combiner Shelf Parts List

AFL Part Nō.	Part Description	Qty.
05-003001	COUPLER 900MHz 4 PORT(THC-900)	1
07-004804	500/800MHz CROSS BAND COUPLER SMA	2
07-005705	CROSSBAND CPLR XC 250/380 SMA	2
09-002101	50W DUMMY LOAD DC-2.5GHz N FEMALE	1
19-000922K	3U CHASSIS KIT (450mm deep)	1
91-030002	N ADAPTOR PANEL FEMALE:FEMALE	7

4.6.4 Multiband Combiner Shelf System Diagram, Drg. # 50-146785

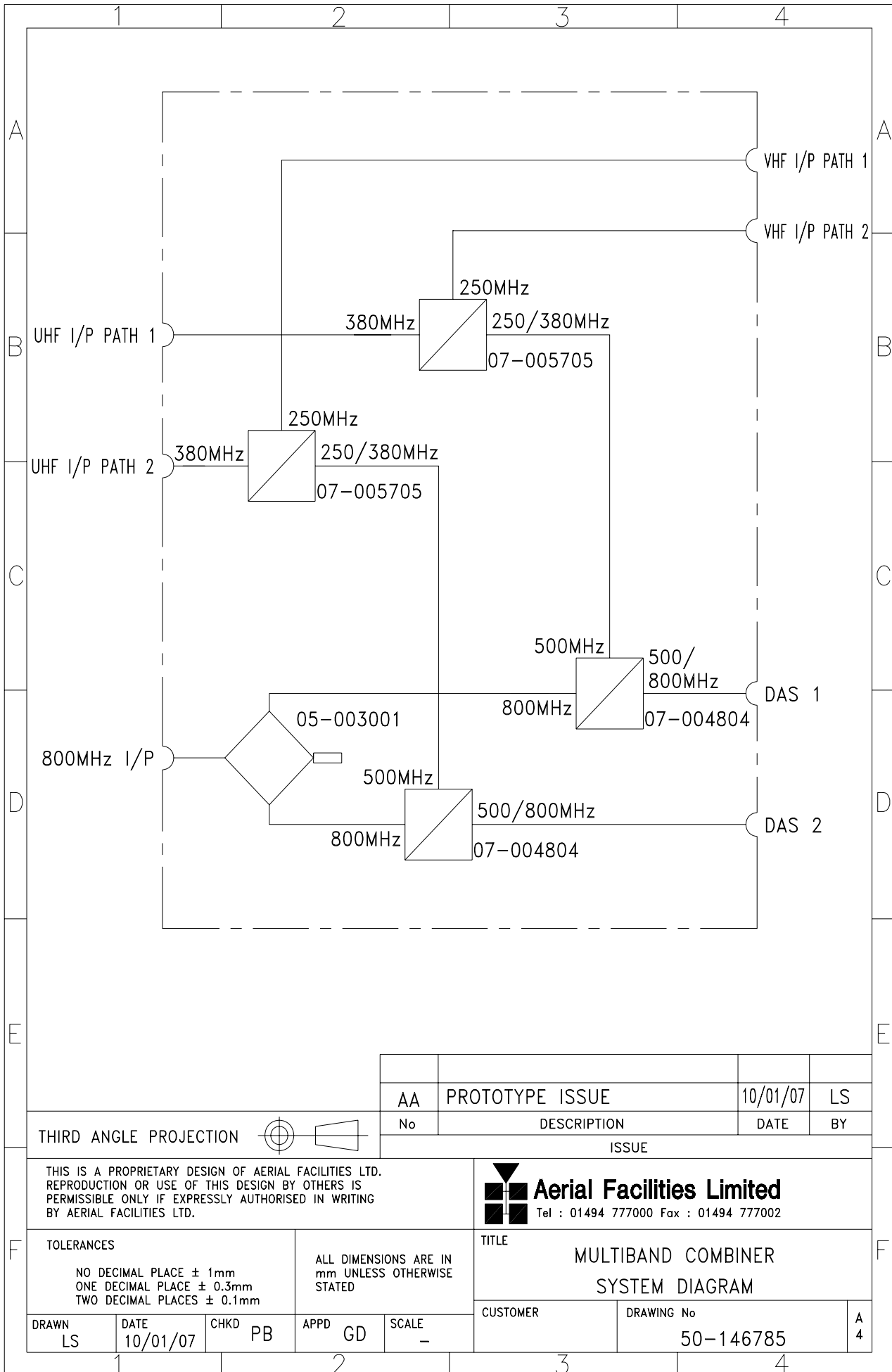

AA	PROTOTYPE ISSUE	10/01/07	LS
No	DESCRIPTION	DATE	BY
ISSUE			

THIRD ANGLE PROJECTION

THIS IS A PROPRIETARY DESIGN OF AERIAL FACILITIES LTD.
 REPRODUCTION OR USE OF THIS DESIGN BY OTHERS IS
 PERMISSIBLE ONLY IF EXPRESSLY AUTHORISED IN WRITING
 BY AERIAL FACILITIES LTD.

Aerial Facilities Limited
 Tel : 01494 777000 Fax : 01494 777002

TOLERANCES
 NO DECIMAL PLACE ± 1mm
 ONE DECIMAL PLACE ± 0.3mm
 TWO DECIMAL PLACES ± 0.1mm

ALL DIMENSIONS ARE IN mm UNLESS OTHERWISE STATED

TITLE
MULTIBAND COMBINER SYSTEM DIAGRAM

DRAWN LS	DATE 10/01/07	CHKD PB	APPD GD	SCALE -	CUSTOMER	DRAWING No 50-146785	A 4
-------------	------------------	------------	------------	------------	----------	-------------------------	--------

5. INSTALLATION

5.1 Initial Installation Record

When this equipment is initially commissioned, please use the equipment set-up record sheet in Appendix B. This will help both the installation personnel and AFL should these figures be needed for future reference or diagnosis.

6. FAULT FINDING & MAINTENANCE

6.1 General Fault Finding Procedures

In the event that the performance of the system is suspect, a methodical and logical approach to the problem will reveal the cause of the difficulty.

Transmissions from the main base stations are passed through the system to the mobile radio equipment; this could be a handheld radio or a transceiver in a vehicle. This path is referred to as the downlink. The return signal path from the mobile radio equipment to the base station is referred to as the uplink.

The first operation is to check the alarms of each of the active units and determine that the power supplies to the equipment are connected and active.

This can be achieved remotely (via CEMS, the RS232 Coverage Enhancement Management System, if fitted), or locally with the front panel LEDs. The green LED on the front panel should be illuminated, while the red alarm indicator should be off.

If an alarm is on, then that individual shelf/module must be isolated and individually tested against the original test specification.

The individual amplifier units have a green LED showing through a hole in their case, which is illuminated if the unit is working correctly.

If an amplifier is suspect, check the DC power supply to the unit. If no other fault is apparent use a spectrum analyser to measure the incoming signal level at the input and then after reconnecting the amplifier input, measure the output level. Consult with the system diagram to determine the expected gain and compare result.

In the event that there are no alarms on and all units appear to be functioning it will be necessary to test the system in a systematic manner to confirm correct operation.

5.2 Downlink

Confirm that there is a signal at the expected frequency and strength from the base station. If this is not present then the fault may lay outside the system. To confirm this, inject a downlink frequency signal from a known source at the master site BTS input and check for output at the remote site feeder output.

If a signal is not received at the output it will be necessary to follow the downlink path through the system to find a point at which the signal is lost. The expected downlink output for the given input can be found in the end-to-end test specification.

5.3 Uplink

Testing the uplink involves a similar procedure to the downlink except that the frequencies used are those transmitted by the mobile equipment.

5.4 Fault repair

Once a faulty component has been identified, a decision must be made on the appropriate course to carry out a repair. A competent engineer can quickly remedy typical faults such as faulty connections or cables. The exceptions to this are cable assemblies connecting bandpass filter assemblies that are manufactured to critical lengths to maintain a 50-ohm system. Care should be taken when replacing cables or connectors to ensure that items are of the correct specification. The repair of component modules such as amplifiers and bandpass filters will not usually be possible in the field, as they frequently require specialist knowledge and test equipment to ensure correct operation. It is recommended that items of this type are replaced with a spare unit and the faulty unit returned to AFL for repair.

5.5 Checking service

Following the repair of any part of the system it is recommended that a full end-to-end test is carried out in accordance with the test specification and that the coverage is checked by survey. It is important to bear in mind that the system includes a radiating cable network and base stations that may be faulty or may have been damaged.

5.6 Service Support

Advice and assistance with maintaining and servicing this system are available by contacting Aerial Facilities Ltd.

5.7 Tools & Test Equipment

The minimum tools and test equipment needed to successfully service this AFL product are as follows:-

Spectrum analyser:	100kHz to 2GHz (Dynamic range = 90dB).
Signal Generator:	30MHz to 2GHz (-120dBm to 0dBm o/p level).
Attenuator:	20dB, 10W, DC-2GHz, (N male – N female).
Test Antenna:	Yagi or dipole for operating frequency.
Digital multi-meter:	Universal Volt-Ohm-Amp meter.
Test cable x 2:	N male – N male, 2M long RG214.
Test cable x 2:	SMA male – N male, 1m long RG223.
Hand tools:	Philips #1&2 tip screwdriver. 3mm flat bladed screwdriver. SMA spanner and torque setter.

5.8 General Maintenance Procedures

Many of the active modules contain semiconductor devices utilising MOS technology, which can be damaged by electrostatic discharge. Correct handling of such modules is mandatory to ensure their long-term reliability.

To prevent damage to a module, it must be withdrawn/inserted with care. The module may have connectors on its underside, which might not be visible to the service operative.

5.9 Module Removal (LNAs, general procedure)

The following general rules should be followed to remove a module:

- 1 Remove power to the unit
- 2 Remove all visible connectors (RF, DC & alarm)
- 3 Release module retaining screws.
- 4 Slowly but firmly, pull the module straight out of its position. Take care not to twist/turn the module during withdrawal. (When the module is loose, care may be needed, as there may be concealed connections underneath).

5.10 Module Replacement (general)

- 1 Carefully align the module into its location then slowly push the module directly straight into its position, taking care not to twist/turn it during insertion.
- 2 Reconnect all connectors, RF, alarm, power etc., (concealed connectors may have to be connected first).
- 3 Replace retaining screws (if any).
- 4 Double-check all connections before applying power.

5.11 Power Amplifiers

- 1) Remove power to the unit. (Switch off at the mains/battery, or remove DC in connector)
- 2) Remove alarm wires from alarm screw terminal block or disconnect multi-way alarm connector.
- 3) Carefully disconnect the RF input and output coaxial connectors (usually SMA)

If alarm board removal is not required, go to step 5.

- 4) There is (usually) a plate attached to the alarm board which fixes it to the amplifier, remove its retaining screws and the alarm board can be withdrawn from the amplifier in its entirety. On certain types of amplifier the alarm board is not mounted on a dedicated mounting plate; in this case it will have to firstly be removed by unscrewing it from the mounting pillars, in most cases, the pillars will not have to be removed before lifting the amplifier.
- 5) If the amplifier to be removed has a heatsink attached, there may be several different ways it can have been assembled. The most commonly used method, is screws through the front of the heatsink to threaded screw holes (or nuts and bolts), into the amplifier within the main case. If the heatsink is mounted on the rear of the main case (e.g., against a wall in the case of wall mounted enclosures), then the fixing method for the heatsink will be from within the case, (otherwise the enclosure would have to be removed from the wall in order to remove the heatsink).

When the heatsink has been removed, the amplifier may be unscrewed from the main casing by its four corner fixings and gently withdrawn.

Fitting a new power amplifier module will be the exact reverse of the above.

Note: Do not forget to apply fresh heatsink compound to the heatsink/main case joint and also between the amplifier and the main case.

5.12 Low Power Amplifier Replacement

Disconnect the mains power supply and disconnect the 24V dc supply connector for the LPA.

Disconnect the RF input and output cables from the LPA.

Disconnect the alarm connector.

Remove the alarm monitoring wires from (D type connector) pins 9 and 10.

Remove the LPA module by removing the four retaining screws, replace with a new LPA module and secure it with the screws.

Connect the RF cables to the LPA input and output connectors. Reconnect the wires to the alarm board connector pins 9 and 10.

Reconnect the DC supply connector and turn the mains switch on.

Note: Tighten SMA connectors using only a dedicated SMA torque spanner. If SMA connectors are over-tightened, irreparable damage will occur. Do not use adjustable pliers to loosen/tighten SMA connectors.

Also take care not to drop or knock the module as this can damage (or misalign in the case of tuned passive modules) sensitive internal components. Always store the modules in an environmentally friendly location

5.13 Module Transportation

To maintain the operation, performance and reliability of any module it must be stored and transported correctly. Any module not installed in a whole system must be kept in an anti-static bag or container. These bags or containers are normally identified by being pink or black, and are often marked with an ESD label. Any module sent back to AFL for investigation/repair must be so protected. Please contact AFL's quality department before returning a module.

APPENDIX A

Amendment List Record Sheet

Issue No.	Date	Incorporated by	Page Nos. Amended	Reason for new issue
A	18/10/2006	CMH		1st Draft
1		CMH		1 st Issue

Document Ref.: 80-283501HBKM

Glossary of Terms

Repeater or Cell Enhancer	A Radio Frequency (RF) amplifier which can simultaneously amplify and re-broadcast Mobile Station (MS) and Base Transceiver Station (BTS) signals.
Band Selective Repeater	A Cell Enhancer designed for operation on a range of channels within a specified frequency band.
Channel Selective Repeater	A Cell Enhancer, designed for operation on specified channel(s) within a specified frequency band. Channel frequencies may be factory set or on-site programmable.
AC	Alternating Current
AGC	Automatic Gain Control
BBU	Battery Backup Unit
BTS	Base Transceiver Station
CEMS	Coverage Enhanced Management System
C/NR	Carrier-to-Noise Ratio
DC	Direct Current
Downlink (D/L)	RF signals TX from the BTS to the Master Site
FO	Fibre Optic
GND	Ground
ID	Identification Number
LED	Light Emitting Diode
LNA	Low Noise Amplifier
LPA	Low Power Amplifier
MOU	Master Optical Unit
M.S.	Mobile Station
MTBF	Mean Time Between Failures
N/A	Not Applicable
N/C	No Connection
OFR	On Frequency Repeater
OIP3	Output Third Order Intercept Point = $RF_{out} + (C/I)/2$
PA	Power Amplifier
RF	Radio Frequency
RSA	Receiver/Splitter Amplifier
RX	Receiver
S/N	Serial Number
TX	Transmitter
Uplink (U/L)	RF signals transmitted from the MS to the BTS
VSWR	Voltage Standing Wave Ratio
WDM	Wave division multiplex

Key to AFL Drawing Symbols

		1	2	3	4	5	6	7	8	9															
A	HUBS	Fibre Main Hub 	Expansion Hub 	Tapper Coupler 	COUPLERS						ANTENNAS														
					10dB Coupler 	6dB Directional Coupler 	10dB Directional Coupler 	6dB Directional Coupler 	Directional Coupler 	Cross Band Coupler 	8/Fibre Optic Cable/Link 	24/Fibre Optic Cable/Link 	Jumper Cable 1/2" 	Radiating Cable 	CAT 5 Cable 	Co-Ax Cable 1/2" DIA 	Co-Ax Cable 7/8" DIA 	Hybrid Splitter 	Splitter 	Omni Antenna 	Yagi Antenna 	Flat Plate Antenna (Mounted at High Level) 	Directional Antenna 	Antenna 	Remote Antenna Unit
B	MISC	Base Transceiver Station 	Channel Module 	Fibre Optic Modulator 	Fibre Optic Demodulator 	Plug & Socket 	Socket 	Plug 	Fibre Optic Connector FC/APC 	MISC						MISC									
					Band Pass Filter 	Cavity Resonator 	Notch Filter 	Isolator 	Hybrid Combiner 	Earth Stud 	Leaky Feeder 	R.S.A 	Amplifier 	Attenuator (Variable) 	Attenuator (Fixed) 	A.G.C 	Monitoring Controller 	Modem 	Bi-Directional Amplifier (Cell Enhancer) 	Dummy Load 	Local Oscillator 	AC to DC PSU 	DC to DC Converter 	Fuse 	N.O. (Clear Contact)
C	MISC	MISC						MISC						MISC		MISC									
		MISC						MISC						MISC		MISC									
D	MISC	MISC						MISC						MISC		MISC									
		MISC						MISC						MISC		MISC									
E	MISC	MISC						MISC						MISC		MISC									
		MISC						MISC						MISC		MISC									
DRAWN		PL	DATE	TITLE		THIRD ANGLE PROJECTION		ISSUE		DESCRIPTION		DATE		BY											
10/05/00		PL	10/05/00	AFL - STANDARD SYMBOLS		THIRD ANGLE PROJECTION		ISSUE		DESCRIPTION		DATE		BY											
CHKD		MB	APPD	Aerial Facilities Limited England		THIRD ANGLE PROJECTION		ISSUE		DESCRIPTION		DATE		BY											
ALL DIMENSIONS ARE IN mm UNLESS OTHERWISE STATED		GD		Tel : 01494 777000 Fax : 01494 777002		THIRD ANGLE PROJECTION		ISSUE		DESCRIPTION		DATE		BY											
TOLERANCES		SCALE		Aerial Facilities Limited England		THIRD ANGLE PROJECTION		ISSUE		DESCRIPTION		DATE		BY											
NO DECIMAL PLACE ± 1mm ONE DECIMAL PLACE ± 0.3mm TWO DECIMAL PLACES ± 0.1mm		NTS		Tel : 01494 777000 Fax : 01494 777002		THIRD ANGLE PROJECTION		ISSUE		DESCRIPTION		DATE		BY											
DRAWING No		CUSTOMER		AFL - STANDARD SYMBOLS		THIRD ANGLE PROJECTION		ISSUE		DESCRIPTION		DATE		BY											
90-000001		DRAWING No		AFL - STANDARD SYMBOLS		THIRD ANGLE PROJECTION		ISSUE		DESCRIPTION		DATE		BY											
A		3		90-000001		THIRD ANGLE PROJECTION		ISSUE		DESCRIPTION		DATE		BY											
1		2		9		THIRD ANGLE PROJECTION		ISSUE		DESCRIPTION		DATE		BY											

EC Declaration of Conformity

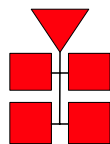

Aerial Facilities Limited

In accordance with BS EN ISO/IEC 17050-1&-2:2004

Aerial Facilities Limited
Aerial House
Asheridge Road
Chesham
Buckinghamshire HP5 2QD
United Kingdom

CE0086

DECLARES, UNDER OUR SOLE RESPONSIBILITY THAT THE FOLLOWING PRODUCT:
PRODUCT PART NO[S]: 50-146501, 50-146601, 50-146701
PRODUCT DESCRIPTION: Radio Repeater Equipment

IN ACCORDANCE WITH THE FOLLOWING DIRECTIVES:

1999/5/EC The Radio & Telecommunications Terminal Equipment Directive Annex V
and its amending directives

HAS BEEN DESIGNED AND MANUFACTURED TO THE FOLLOWING STANDARD[S] OR
OTHER NORMATIVE DOCUMENT[S]:

BS EN 60950 Information technology equipment.
Safety. General requirements

ETS EN 301 489-1 EMC standard for radio equipment and services.
Part 1. Common technical requirements

I hereby declare that the equipment named above has been designed to comply with the relevant sections of the above referenced specifications. The unit complies with all essential requirements of the Directives.

SIGNED

B S BARTON
TECHNICAL DIRECTOR

DATE: 12/01/2007

APPENDIX B

Initial Equipment Set-Up Calculations

General Information

Site Name:

Client Name:

Date:

AFL Equip. Model No.

Antenna Systems

	Model	Gain	Azimuth	Comments
A - Service Antenna				
B - Donor Antenna				
	Type	Loss	Length	Comments
C - Service Feeder				
D - Donor Feeder				

Initial Parameters

E - CE Output Power					dBm
F - Antenna Isolation					dB
G - Input signal level from donor BTS					dBm
Operating Voltage					V

Downlink Calculations

Parameter	Comments	Value	
Input signal level (G)			dBm
CE max. o/p power (E)			dBm
Gain setting	E - G		dB
Isolation required	(Gain + 10dB)		dB
Service antenna gain (A)			dB
Service antenna feeder loss (C)			dB
Effective radiated power (ERP)	E+A-C		dBm
Attenuator setting	CE gain-gain setting		dB

If the input signal level in the uplink path is known and steady, use the following calculation table to determine the gain setting. If the CE features Automatic Gain Control the attenuator should be set to zero and if not, then the attenuation setting for both uplink and downlink should be similar.

Uplink Calculations

Parameter	Comments	Value	
Input signal level			dBm
CE max. o/p power (E)			dBm
Gain setting			dB
Required isolation			dB
Donor antenna gain (B)			dB
Donor antenna feeder loss (D)			dB
Effective radiated power (ERP)	E+B-D		dBm
Attenuator setting	(CE gain-gain setting)		dB