



**5 Ch. VHF Radio Repeater Equipment
(Bi-directional Amplifier)
For
Day Wireless Systems**

**AFL Works Order Q116073
AFL Product Part No. 50-189201 (5 Ch. VHF System 80dB)**

Table of Contents

1.	INTRODUCTION.....	4
1.1.	Scope and Purpose of Document.....	4
1.2.	Limitation of Liability Notice	4
2.	SAFETY CONSIDERATIONS	5
2.1.	Earthing of Equipment	5
2.2.	Electric Shock Hazard.....	5
2.3.	RF Radiation Hazard	5
2.4.	Lifting and other Health and Safety Recommendations.....	5
2.5.	Chemical Hazard	6
2.6.	Laser Safety.....	6
2.7.	Emergency Contact Numbers.....	6
3.	EQUIPMENT OVERVIEW.....	7
3.1.	Overall System Diagram.....	8
4.	BDA VHF SYSTEM RACK 1 (50-189212)	9
4.1.	BDA VHF System Rack 1 (50-189212) System diagram.....	10
4.2.	BDA VHF System Rack 1 (50-189212) Photographs	11
4.3.	BDA VHF Downlink Output Combiner (50-189208).....	13
4.3.1.	BDA VHF Downlink Output Combiner (50-189208) Major Components.....	13
4.3.2.	BDA VHF Downlink Output Combiner (50-189208) System diagram	14
4.4.	BDA VHF Uplink Input Splitter (50-189210).....	15
4.4.1.	BDA VHF Uplink Input Splitter (50-189210) Major Components.....	15
4.4.2.	BDA VHF Uplink Input Splitter (50-189210) System diagram	16
4.5.	BDA VHF Channel Shelves (50-189202 to 50-189206)	17
4.5.1.	BDA VHF Channel Shelves Major Components	17
4.5.2.	BDA VHF Channel 1 Shelf (50-189202) System diagram.....	20
4.5.3.	BDA VHF Channel 2 Shelf (50-189203) System diagram.....	21
4.5.4.	BDA VHF Channel 3 Shelf (50-189204) System diagram.....	22
4.5.5.	BDA VHF Channel 4 Shelf (50-189205) System diagram.....	23
4.5.6.	BDA VHF Channel 5 Shelf (50-189206) System diagram.....	24
4.6.	BDA VHF UPLINK OUTPUT COMBINER (50-189209).....	25
4.6.1.	BDA VHF Uplink Output Combiner (50-189209) Major Components.....	25
4.6.2.	BDA VHF Uplink Output Combiner (50-189209) System Diagram	26
4.7.	BDA VHF DOWNLINK INPUT SPLITTER (50-189207).....	27
4.7.1.	BDA VHF Downlink Input Splitter (50-189207) Major Components	27
4.7.2.	BDA VHF Downlink Input Splitter (50-189207) System Diagram.....	28
4.8.	24V PSU Shelf (50-146512)	29
4.8.1.	24V PSU Shelf (50-146512) Specification	29
4.8.2.	24V PSU Shelf (50-146512) Major Components	29
4.8.2.	24V PSU Shelf (50-146512) System Diagram	31
5.	BDA VHF SYSTEM RACK 2 (50-189213)	32
5.1.	BDA VHF System Rack 2 (50-189213) System Diagram	34
5.2.	Hybrid Splitter/Combiner Tray (50-189211).....	35
5.2.1.	Hybrid Splitter/Combiner Tray (50-189211) Major Components	35
5.2.2.	Hybrid Splitter/Combiner Tray (50-189211) System Diagram	36
6.	BDA VHF SYSTEM RACK 3 (50-189214)	37
6.1.	BDA VHF System Rack 3 (50-189214) System Diagram	39
7.	INSTALLATION.....	40
7.1	Initial Installation Record.....	40
8.	FAULT FINDING & MAINTENANCE.....	40
8.1	General Fault Finding Procedures.....	40
8.2	Downlink	40
8.3	Uplink.....	41
8.4	Fault repair.....	41
8.5	Checking service.....	41
8.6	Service Support	41
8.7	Tools & Test Equipment.....	41

8.8	General Maintenance Procedures	42
8.9	Module Removal (LNAs, general procedure).....	42
8.10	Module Replacement (general)	42
8.11	Power Amplifiers.....	42
8.12	Low Power Amplifier Replacement.....	43
8.13	Module Transportation.....	43
APPENDIX A		44
A.1.	Glossary of Terms used in this document	44
A.2.	Key to Drawing Symbols used in this document.....	45
A.3.	EC Declaration of Conformity	46
A.4.	Amendment List Record Sheet.....	47

1. INTRODUCTION

1.1. Scope and Purpose of Document

This handbook is for use solely with the equipment identified by the Aerial Facilities Limited (AFL) Part Number shown on the front cover. It is not to be used with any other equipment unless specifically authorised by AFL. This is a controlled release document and, as such, becomes a part of Aerial Facilities' Total Quality Management System. Alterations and modification may therefore only be performed by AFL.

AFL recommends that the installer of this equipment familiarise themselves with the safety and installation procedures contained within this document before installation commences.

The purpose of this handbook is to provide the user/maintainer with sufficient information to service and repair the equipment to the level agreed. Maintenance and adjustments to any deeper level must be performed by AFL, normally at the company's repair facility in Chesham, England.

This handbook has been prepared in accordance with BS 4884, and AFL's Quality procedures, which maintain the company's registration to BS EN ISO 9001:2000 and to the R&TTE Directive of the European Parliament. Copies of the relevant certificates and the company Quality Manual can be supplied on application to the Quality Manager.

This document fulfils the relevant requirements of Article 6 of the R&TTE Directive.

1.2. Limitation of Liability Notice

This manual is written for the use of technically competent operators/service persons. No liability is accepted by AFL for use or misuse of this manual, the information contained therein, or the consequences of any actions resulting from the use of the said information, including, but not limited to, descriptive, procedural, typographical, arithmetical, or listing errors.

Furthermore, AFL does not warrant the absolute accuracy of the information contained within this manual, or its completeness, fitness for purpose, or scope.

AFL has a policy of continuous product development and enhancement, and as such, reserves the right to amend, alter, update and generally change the contents, appearance and pertinence of this document without notice.

All AFL products carry a twelve month warranty from date of shipment. The warranty is expressly on a return to base repair or exchange basis and the warranty cover does not extend to on-site repair or complete unit exchange.

2. SAFETY CONSIDERATIONS

2.1. Earthing of Equipment



Equipment supplied from the mains must be connected to grounded outlets and earthed in conformity with appropriate local, national and international electricity supply and safety regulations.

2.2. Electric Shock Hazard

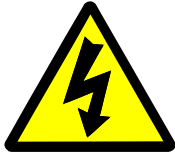

The risk of electrical shocks due to faulty mains driven power supplies whilst potentially ever present in any electrical equipment, would be minimised by adherence to good installation practice and thorough testing at the following stages:

- a) Original assembly.
- b) Commissioning.
- c) Regular intervals, thereafter.

All test equipment must be in good working order prior to its use. High current power supplies can be dangerous because of the possibility of substantial arcing. Always switch off during disconnection and reconnection.

2.3. RF Radiation Hazard



RF radiation, (especially at UHF frequencies) arising from transmitter outputs connected to AFL's equipment, must be considered a safety hazard.

This condition might only occur in the event of cable disconnection, or because a 'spare' output has been left un-terminated. Either of these conditions would impair the system's efficiency. No investigation should be carried out until all RF power sources have been removed. This would always be a wise precaution, despite the severe mismatch between the impedance of an N type connector at 50Ω , and that of free space at 377Ω , which would severely mitigate against the efficient radiation of RF power. Radio frequency burns could also be a hazard, if any RF power carrying components were to be carelessly touched!

Antenna positions should be chosen to comply with requirements (both local & statutory) regarding exposure of personnel to RF radiation. When connected to an antenna, the unit is capable of producing RF field strengths, which may exceed guideline safe values especially if used with antennas having appreciable gain. In this regard the use of directional antennas with backscreens and a strict site rule that personnel must remain behind the screen while the RF power is on, is strongly recommended.

Where the equipment is used near power lines or in association with temporary masts not having lightning protection, the use of a safety earth connected to the case-earthing bolt is strongly advised.

2.4. Lifting and other Health and Safety Recommendations



Certain items of AFL equipment are heavy and care should be taken when lifting them by hand. Ensure that a suitable number of personnel, appropriate lifting apparatus and appropriate personal protective equipment is used especially when installing Cell Enhancers above ground e.g. on a mast or pole.

2.5. Chemical Hazard



Beryllium Oxide, also known as Beryllium Monoxide, or Thermalox™, is sometimes used in devices within equipment produced by Aerial Facilities Ltd. Beryllium oxide dust can be toxic if inhaled, leading to chronic respiratory problems. It is harmless if ingested or by contact.

Products that contain beryllium are load terminations (dummy loads) and some power amplifiers. These products can be identified by a yellow and black “skull and crossbones” danger symbol (shown above). They are marked as hazardous in line with international regulations, but pose no threat under normal circumstances. Only if a component containing beryllium oxide has suffered catastrophic failure, or exploded, will there be any danger of the formation of dust. Any dust that has been created will be contained within the equipment module as long as the module remains sealed. For this reason, any module carrying the yellow and black danger sign should not be opened. If the equipment is suspected of failure, or is at the end of its life-cycle, it must be returned to Aerial Facilities Ltd for disposal.

To return such equipment, please contact the Quality Department, who will give you a Returned Materials Authorisation (RMA) number. Please quote this number on the packing documents, and on all correspondence relating to the shipment.

PolyTetraFluoroEthylene, (P.T.F.E.) and P.T.F.E. Composite Materials

Many modules/components in AFL equipment contain P.T.F.E. as part of the RF insulation barrier. This material should never be heated to the point where smoke or fumes are evolved. Any person feeling drowsy after coming into contact with P.T.F.E. especially dust or fumes should seek medical attention.

2.6. Laser Safety



General good working practices adapted from
EN60825-2: 2004/ EC 60825-2:2004

Do not stare with unprotected eyes or with any unapproved optical device at the fibre ends or connector faces or point them at other people, Use only approved filtered or attenuating viewing aids.

Any single or multiple fibre end or ends found not to be terminated (for example, matched, spliced) shall be individually or collectively covered when not being worked on. They shall not be readily visible and sharp ends shall not be exposed.

When using test cords, the optical power source shall be the last connected and the first disconnected; use only approved methods for cleaning and preparing optical fibres and optical connectors.

Always keep optical connectors covered to avoid physical damage and do not allow any dirt/foreign material ingress on the optical connector bulkheads.

The optical fibre jumper cable maximum bend radius is 3cm; any smaller radii may result in optical cable breakage or excessive transmission losses.

Caution: The FO units are NOT weather proof.

2.7. Emergency Contact Numbers



The AFL Quality Department can be contacted on:

Telephone +44 (0)1494 777000

Fax. +44 (0)1494 777002

e-mail qa@aerialfacilities.com

3. EQUIPMENT OVERVIEW

5 channel radio repeater 50-189201 is supplied in three 43U equipment mounting racks.

Rack 1 (50-189212) houses the main amplification modules along with the various splitters and combiners.

Rack 2 (50-189213) houses the Cavity Filters for the TX (Downlink) path

Rack 3 (50-189214) houses the Cavity Filters for the RX (Uplink) path

Downlink.

Channel 1 – 154.190MHz

Channel 2 – 154.070MHz

Channel 3 – 158.910MHz

Channel 4 – 155.700MHz

Channel 5 – 158.850 MHz

The input splitter shelf (50-189207) receives Downlink VHF signals from the off-air RX antenna and the signal is split and passed through a series of bandpass and crystal filters. The resultant five signal paths then leave the shelf, each path going to the downlink section of a dedicated amplifier shelf (BDA VHF Channel Shelves 1 to 5, 50-189202/06); these amplifier shelves also contain channel selective modules to achieve the narrow bandwidth required.

Upon leaving the Amplifier shelves the five signal paths enter BDA VHF Downlink Output Combiner (50-189208) where the five separate signal paths are combined into three. The three signal paths are then fed into the cavity combiner in Rack 2 where they are combined into a single signal path before being fed into BDA VHF DAS Hybrid Splitter/Combiner (50-189211) where the signal path is split into two feeds, one for each LCX feed

Uplink

Channel 1 – 156.195MHz

Channel 2 – 155.325MHz

Channel 3 – 154.785MHz

Channel 4 – 154.830MHz

Channel 5 – 156.150 MHz

Uplink signals from the LCX are fed into BDA VHF DAS Hybrid Splitter/Combiner (50-189211) where they are combined into a single signal path and passed into the first stage of the cavity filter in Rack 3. In the first stage cavity filter the signal path is split into three and each path passes through a cavity filtering section and the three signal paths then are fed into the BDA VHF Uplink Input Splitter (50-189210) in Rack 1, here the three paths are split into five and each path passes through a crystal filter which passes the channel required.

Upon leaving the BDA VHF Uplink Input Splitter, each of the five signal paths is fed into the uplink section of a dedicated amplifier shelf (BDA VHF Channel Shelves 1 to 5, 50-189202/06); these amplifier shelves also contain channel selective modules to achieve the narrow bandwidth required.

From the amplifier shelves the five signal paths are fed into the Uplink Output Combiner (50-189209) where the five signal paths are combined into three path before being fed into the second stage of the cavity filter in Rack 3. After passing through the cavity filters the separate signal paths are combined into a single path which passes through a bandpass filter before being fed to the TX antenna

3.1. Overall System Diagram

Drawing number 50-189281

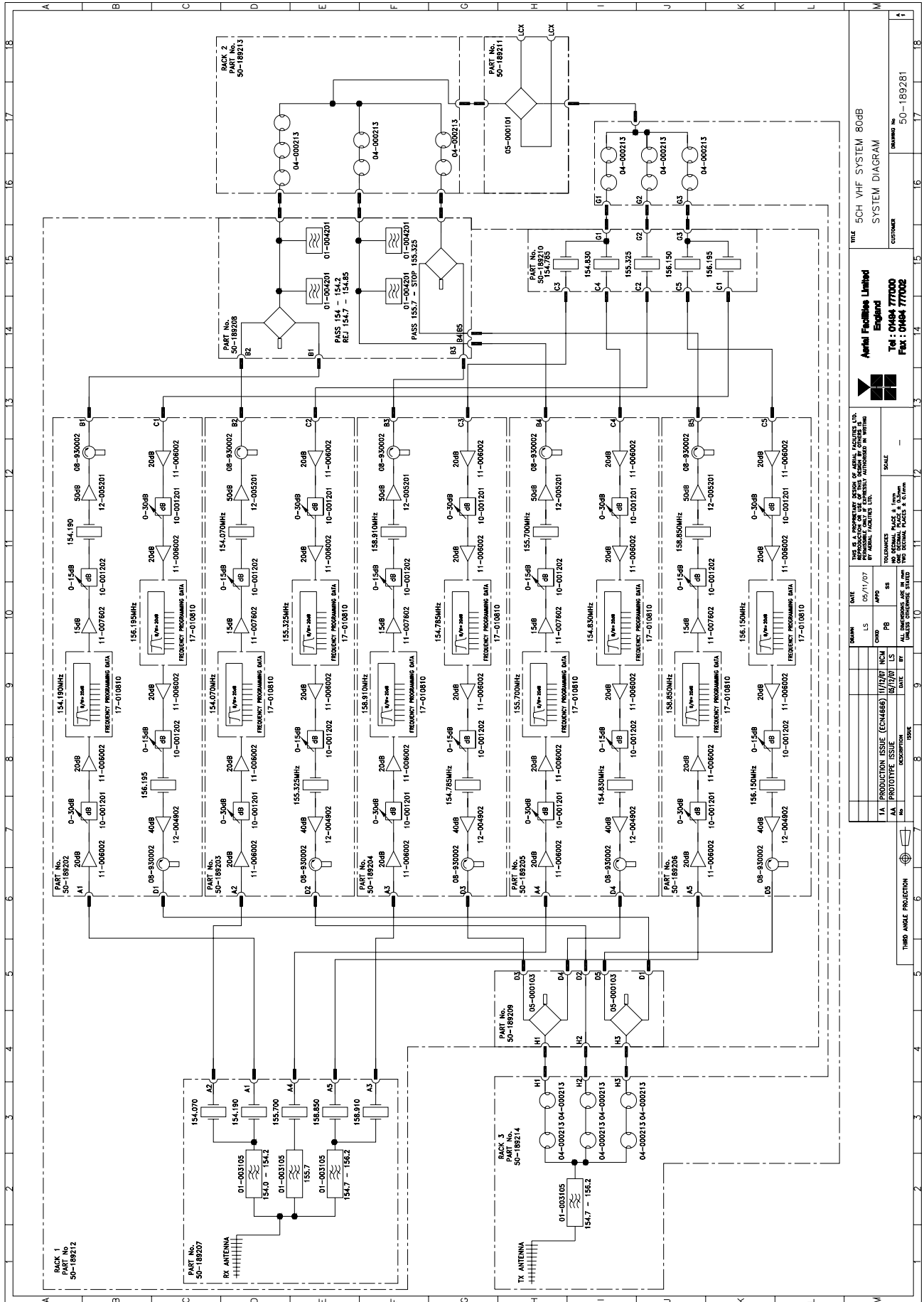

REV	DATE	BY	CHKD	APPD	DESCRIPTION	ISSUE
1A	05/11/07	LS	CMG	PG	PRODUCTION ISSUE (CEN468)	11/12/07 NCM
1A	05/12/07	LS	LS	LS	PROTOTYPE ISSUE	05/12/07 LS

<p>Amel Facilities Limited England Tel : 01464 77000 Fax : 01464 77002</p>	<p>TITLE: 5CH VHF SYSTEM 80dB SYSTEM DIAGRAM CUSTOMER:</p>
---	--

4. BDA VHF SYSTEM RACK 1 (50-189212)

Rack 1 (50-189212) houses the main amplification modules for uplink and downlink along with the various splitters, combiners and the inputs from the RX antenna and the outputs to the TX antenna

Rack 1 is a 43U equipment mounting rack (600mm x 600mm) and comprised of the following modules, listed from the top of the rack

Component Part	Component Part Description	Qty Per Assembly
50-189208	BDA VHF Downlink Output Combiner	1
50-189210	BDA VHF Uplink Input Splitter	1
50-189202	BDA VHF Channel 1 Shelf	1
50-189203	BDA VHF Channel 2 Shelf	1
50-189204	BDA VHF Channel 3 Shelf	1
50-189205	BDA VHF Channel 4 Shelf	1
50-189206	BDA VHF Channel 5 Shelf	1
50-189209	BDA VHF Uplink Output Combiner	1
50-189207	BDA VHF Downlink Input Splitter	1
50-146512	24V PSU Shelf	1

4.1. BDA VHF System Rack 1 (50-189212) System diagram

Drawing number 50-189292

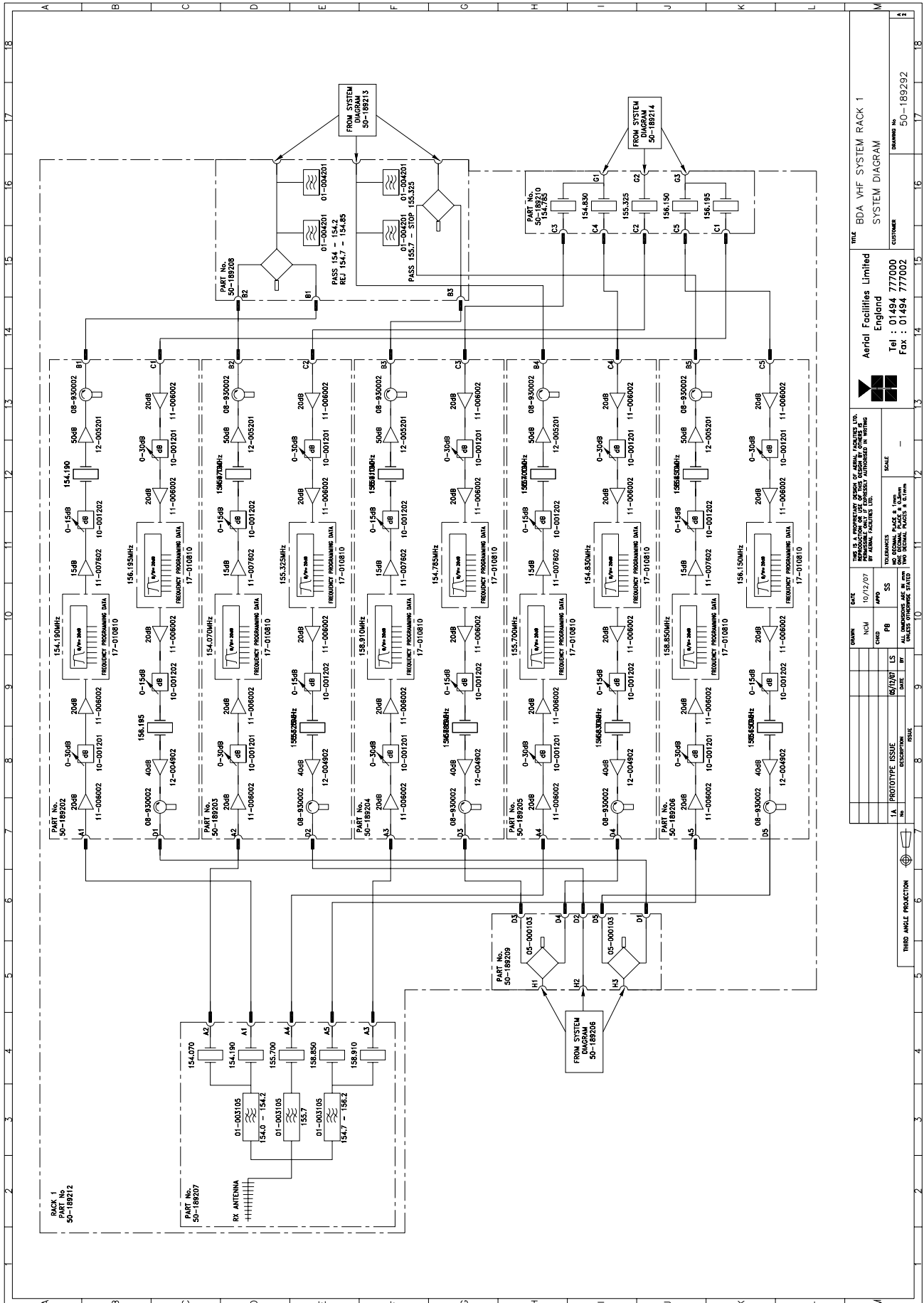

DATE: BDA VHF SYSTEM RACK 1
SYSTEM DIAGRAM
DRAWING No. 50-189292

Aerial Facilities Limited
England
Tel : 01494 777000
Fax : 01494 777002



THIS IS A PROTOTYPE ISSUE OF A SYSTEM DIAGRAM. IT IS NOT TO BE USED FOR CONSTRUCTION OF A SYSTEM WITHOUT THE EXPRESS PERMISSION OF AERIAL FACILITIES LIMITED.

4.2. BDA VHF System Rack 1 (50-189212) Photographs

Top of rack



Rack Interconnections
(see below)

A	BDA VHF Downlink Output Combiner 50-189208
B	BDA VHF Uplink Input Splitter 50-189210
C	BDA VHF Channelised Amplifier Channel 1 Shelf 50-189202
D	BDA VHF Channelised Amplifier Channel 2 Shelf 50-189203
E	BDA VHF Channelised Amplifier Channel 3 Shelf 50-189204
F	BDA VHF Channelised Amplifier Channel 4 Shelf 50-189205
G	BDA VHF Channelised Amplifier Channel 5 Shelf 50-189206
H	2U Blanking Panel
I	1U Blanking Panel

Bottom of rack



I	1U Blanking Panel
J	BDA VHF Uplink Output Combiner 50-189209
K	BDA VHF Downlink Input Splitter 50-189207
L	VHF/UHF System PSU 24v 50-146512
M	2U Blanking Panel
N	3U Blanking Panel

Rack interconnections are on the top of the rack rack

Ant	Connection to RX Antenna
E1	D/L Channel 4 to Cavity Combiner Rack 2
E2	Combined D/L Channel 1 & 2 to Cavity Combiner Rack 2
E3	Combined D/L Channel 3 & 5 to Cavity Combiner Rack 2
G1	Combined U/L Channel 3 & 4 from first stage Cavity Combiner Rack 3
G2	U/L Channel 2 from first stage Cavity Combiner Rack 3
G3	Combined U/L Channel 1 & 5 from first stage Cavity Combiner Rack 3
H1	Combined U/L Channel 3 & 4 to second stage Cavity Combiner Rack 3
H2	U/L Channel 2 to second stage Cavity Combiner Rack 3
H3	Combined U/L Channel 1 & 5 to second stage Cavity Combiner Rack 3

4.3. BDA VHF Downlink Output Combiner (50-189208)

The BDA VHF Downlink Output Combiner takes amplified signals from the Channelised Amplifier shelves in Rack 1 and combines them before passing the signals to the Cavity Combiner in rack 2

Channels 1 and 2 are combined by hybrid combiner (01-004201) and the resultant signal is passed through two notch filters (01-004201) before leaving the shelf to go to the cavity combiner in rack 2

Channels 3 and 5 are combined by hybrid combiner (01-004201) and the resultant signal is passed to the cavity combiner in rack 2

Channel 4 is passed through two notch filters (01-004201) before leaving the shelf to go to the cavity combiner in rack 2

This is a passive shelf and has no connection to the PSU and no alarms.

4.3.1. BDA VHF Downlink Output Combiner (50-189208) Major Components

Component Part	Component Part Description	Qty Per Assembly
01-004201	Notch Filter	4
05-000103	Hybrid combiner	2
97-100010K	5U Rack Mount Chassis	



A	Port E2 Combined D/L Channel 1 & 2 output
B	Port B5 D/L Channel 5 input
C	Port B3 D/L Channel 3 input
D	Port B1 D/L Channel 1 input
E	Port E3 Combined D/L Channel 3 & 5 output
F	Port E1 D/L Channel 4 output
G	Port B4 D/L Channel 4 input
H	Port B2 D/L Channel 2 input

4.3.2. BDA VHF Downlink Output Combiner (50-189208) System diagram

Drawing number 50-189288

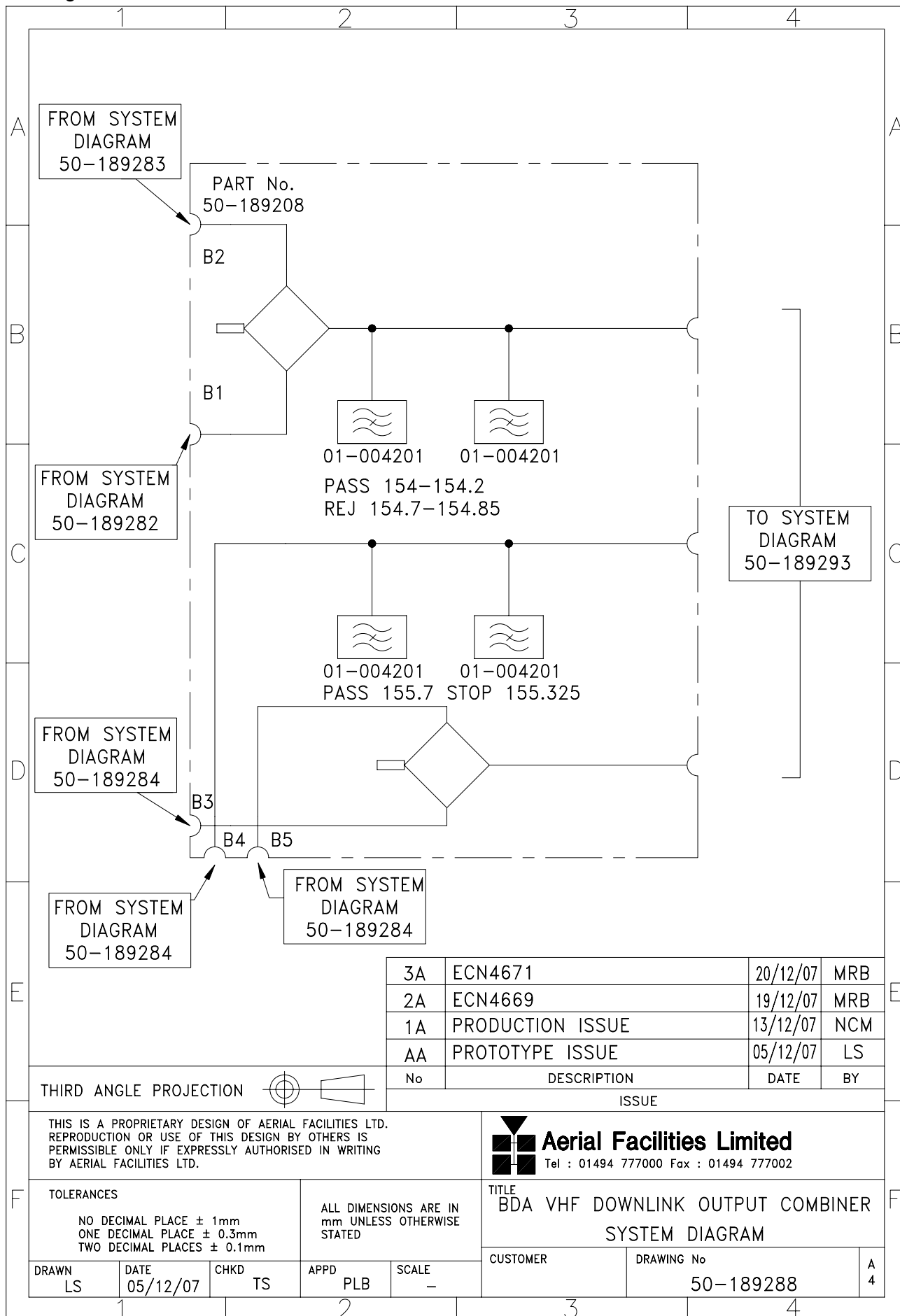

4.4. BDA VHF Uplink Input Splitter (50-189210)

BDA VHF Uplink Input Splitter (50-189210) takes the three signal path inputs from the first stage uplink cavity filter in rack 2 and splits two of the signals to produce five signal paths which are then fed to the crystal filters.

The outputs from the five crystal filters then leave the Uplink Input Splitter shelf to go to the uplink sections of the Channelised Amplifier shelves.

This is a passive shelf and has no connection to the PSU and no alarms,

4.4.1. BDA VHF Uplink Input Splitter (50-189210) Major Components

Component Part	Component Part Description	Qty Per Assembly
19-000822K	2U Rack Mount Chassis	1
93-980196	Crystal Filter 154.785MHz	1
93-980225	Crystal Filter 154.830MHz	1
93-980227	Crystal Filter 155.325MHz	1
93-980228	Crystal Filter 156.150MHz	1
93-980229	Crystal Filter 156.195MHz	1

Top View – lid removed



Close-up of connectors

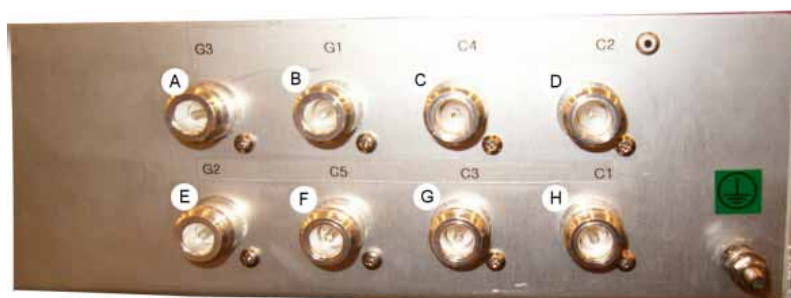

A	Port G3 Input from cavity combiner
B	Port G1 Input from cavity combiner
C	Port C4 U/L Channel 4 output
D	Port C2 U/L Channel 2 output
E	Port G1 Input from cavity combiner
F	Port C5 U/L Channel 5 output
G	Port C3 U/L Channel 3 output
H	Port C1 U/L Channel 1 output

4.4.2. BDA VHF Uplink Input Splitter (50-189210) System diagram

Drawing number 50-189290

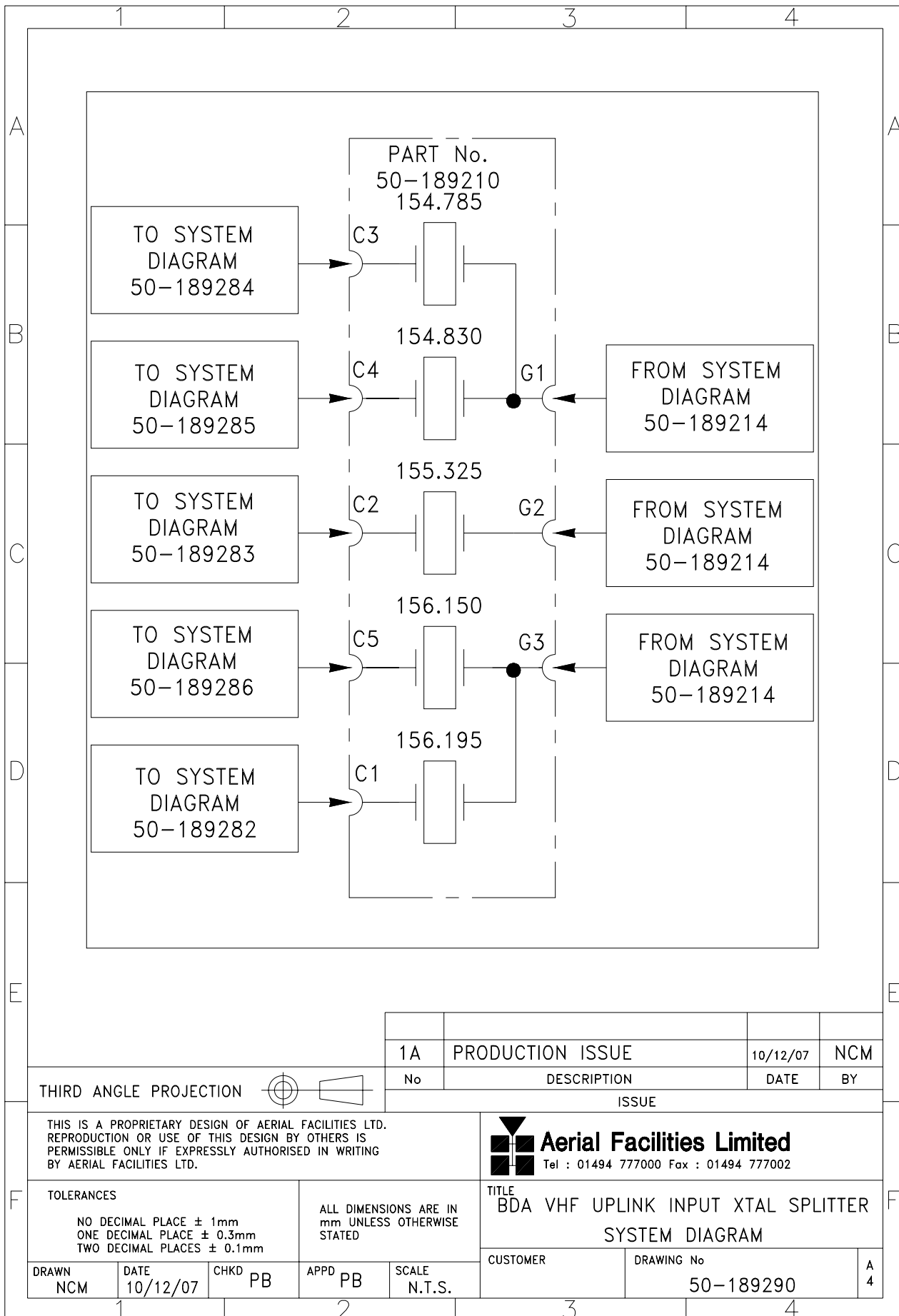

1A	PRODUCTION ISSUE	10/12/07	NCM
No	DESCRIPTION	DATE	BY
ISSUE			

THIRD ANGLE PROJECTION

THIS IS A PROPRIETARY DESIGN OF AERIAL FACILITIES LTD. REPRODUCTION OR USE OF THIS DESIGN BY OTHERS IS PERMISSIBLE ONLY IF EXPRESSLY AUTHORISED IN WRITING BY AERIAL FACILITIES LTD.

Aerial Facilities Limited
Tel : 01494 777000 Fax : 01494 777002

TOLERANCES
NO DECIMAL PLACE ± 1mm
ONE DECIMAL PLACE ± 0.3mm
TWO DECIMAL PLACES ± 0.1mm

ALL DIMENSIONS ARE IN mm UNLESS OTHERWISE STATED

TITLE
BDA VHF UPLINK INPUT XTAL SPLITTER SYSTEM DIAGRAM

DRAWN NCM	DATE 10/12/07	CHKD PB	APPD PB	SCALE N.T.S.	CUSTOMER	DRAWING No 50-189290	A 4
--------------	------------------	------------	------------	-----------------	----------	-------------------------	--------

4.5. BDA VHF Channel Shelves (50-189202 to 50-189206)

Rack 1 contains five Channelised Amplifier shelves, one shelf for each channel. Each shelf is composed of identical sub-modules, the only differences being the frequency that the modules are configured to pass and the part numbers of the crystal filters employed. Each shelf is powered by a 24V DC feed from the PSU (50-146512) and has alarm outputs.

Shelf 1, 50-189202, passes channel 1
Shelf 2, 50-189203, passes channel 2
Shelf 3, 50-189204, passes channel 3
Shelf 4, 50-189205, passes channel 4
Shelf 5, 50-189206, passes channel 5

In the downlink direction, signals are received from the Downlink Input Splitter (50-189207) and pass through a low noise amplifier, one of the two switched attenuators and a second LNA. After the second LNA the signal passes into the channel selectivity module and then into a third LNA. After the third LNA the signal passes through the second switched attenuator and then into a crystal filter which further defines the operating frequency. After the crystal filter the signal passes through a 10W power amplifier and then a ferrite isolator which provides isolation from reflected uplink signals. After passing through the ferrite isolator the signal leaves the Channelised Amplifier shelf and enters the Downlink Output Combiner (50-189208)

In the uplink direction, signals are received from the Uplink Input Splitter (50-189210) and pass through a low noise amplifier, one of the two switched attenuators and a second LNA. After the second LNA the signal passes into the channel selectivity module and then into a third LNA. After the third LNA the signal passes through the second switched attenuator and then into a crystal filter which further defines the operating frequency. After the crystal filter the signal passes through a 5W power amplifier and then a ferrite isolator which provides isolation from reflected downlink signals. After passing through the ferrite isolator the signal leaves the Channelised Amplifier shelf and enters the Uplink Output Combiner (50-189209)

4.5.1. BDA VHF Channel Shelves Major Components

Parts common to all 5 shelves

Component Part	Component Part Description	Qty Per Assembly
08-930002	2 Port Isolator	2
10-000701	Switched Attenuator 0-30dB 0.25W	2
10-000901	Switched Attenuator 0-15dB 0.25W	2
11-006002	LNA VHF 70-500MHz with Relay	5
11-007602	LNA 50-200MHz (HIGH IP3)	1
12-002201	3 Stage Amplifier Alarm Board	2
12-004902	Power Amplifier VHF 5W	1
12-005201	Power Amplifier VHF 10W	1
13-001803	Dual D/DC Convertor 24V-12V 1A	2
17-010810	VHF Channel Selectivity Module	2
19-000922KL	3U Rack Mount Chassis	1
20-001601	12V Relay PCB Assembly	1
80-008902	24V Relay PCB Assembly	1
80-008909	12V Relay PCB Assembly with LED	1

Parts specific to Shelf 1, 50-189202

Component Part	Component Part Description	Qty Per Assembly
93-980196	Crystal Filter 154.785MHz	1
93-980222	Crystal Filter 154.070MHz	1

Parts specific to Shelf 2, 50-189203

Component Part	Component Part Description	Qty Per Assembly
93-980223	Crystal Filter 154.190MHz	1
93-980225	Crystal Filter 154.830MHz	1

Parts specific to Shelf 3, 50-189204

Component Part	Component Part Description	Qty Per Assembly
93-980226	Crystal Filter 155.700MHz	1
93-980227	Crystal Filter 155.325MHz	1

Parts specific to Shelf 4, 50-189205

Component Part	Component Part Description	Qty Per Assembly
93-980228	Crystal Filter 156.150MHz	1
93-980230	Crystal Filter 158.850MHz	1

Parts specific to Shelf 5, 50-189205

Component Part	Component Part Description	Qty Per Assembly
93-980229	Crystal Filter 156.195MHz	1
93-980231	Crystal Filter 158.910MHz	1

Top View – lid removed



A	Downlink Input
B	Downlink Output
C	Uplink Input
D	Uplink Output
E	Alarm Output
F	DC Input (24V)

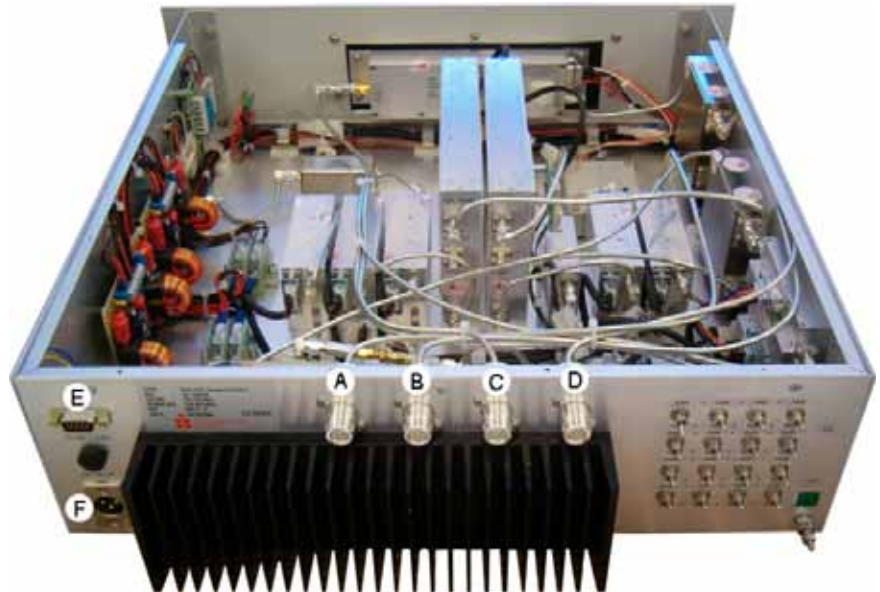

Close-up of attenuator switches

4.5.2. BDA VHF Channel 1 Shelf (50-189202) System diagram

Drawing number 50-189282

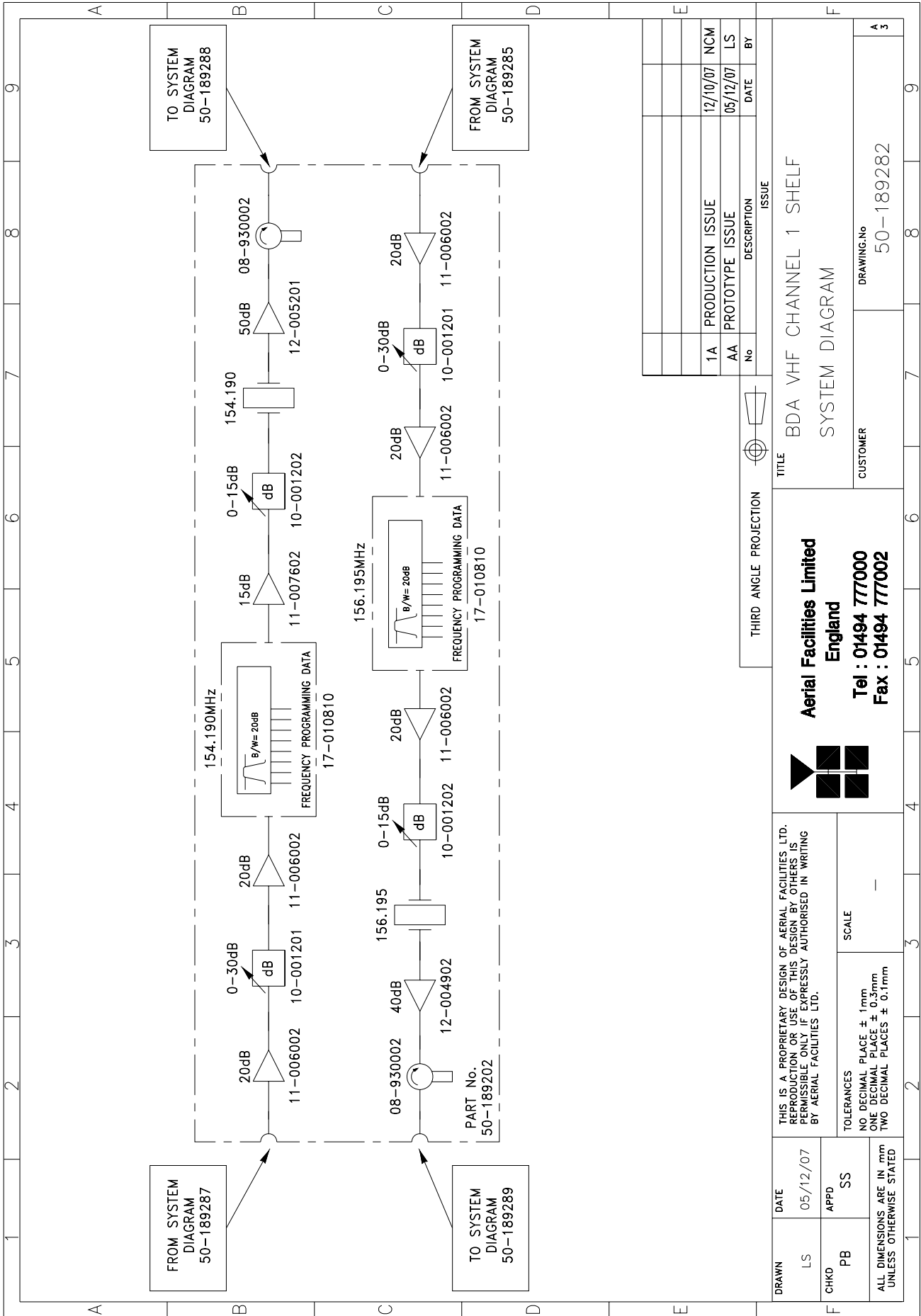

4.5.3. BDA VHF Channel 2 Shelf (50-189203) System diagram

Drawing number 50-189283

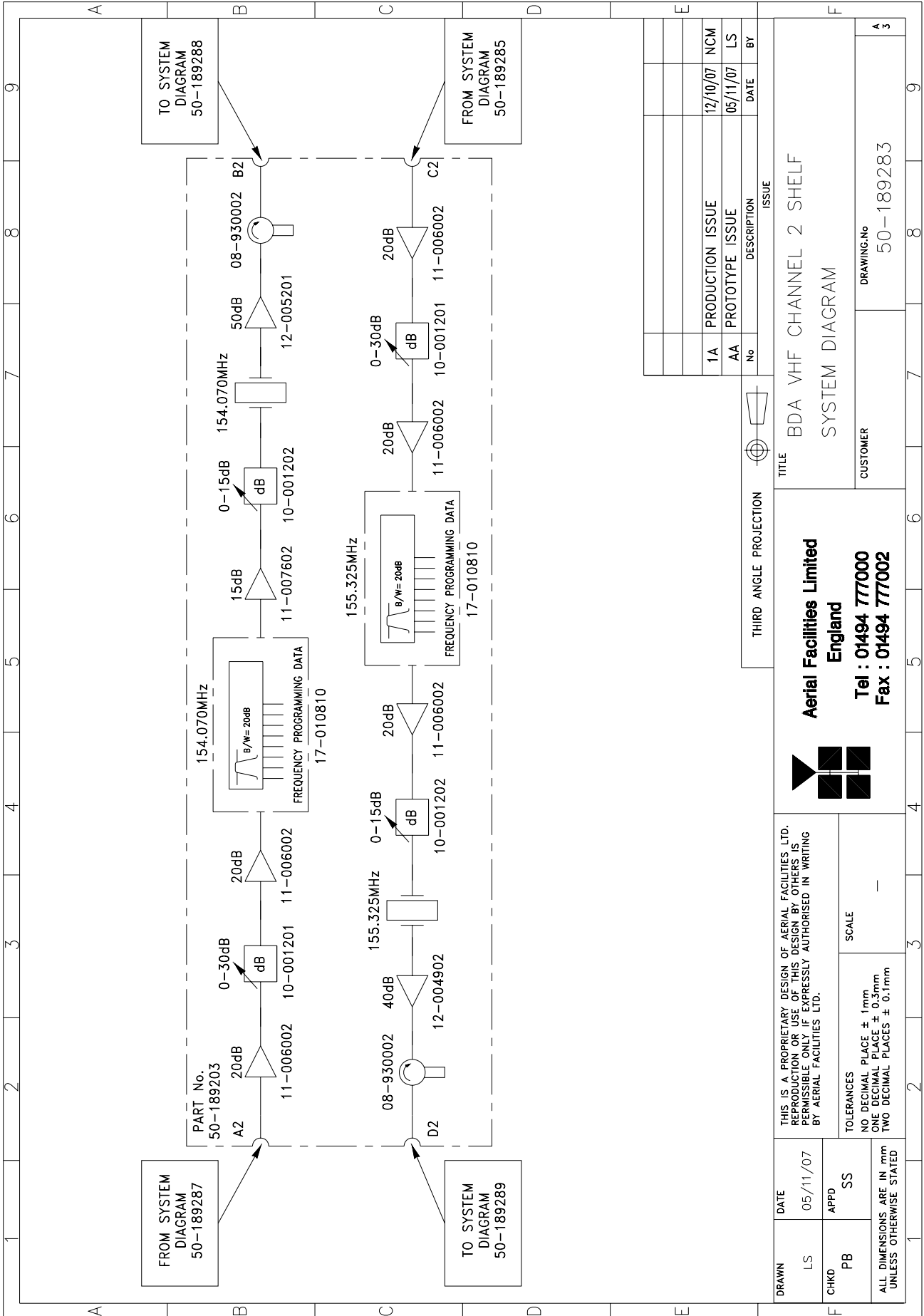

4.5.4. BDA VHF Channel 3 Shelf (50-189204) System diagram

Drawing number 50-189284

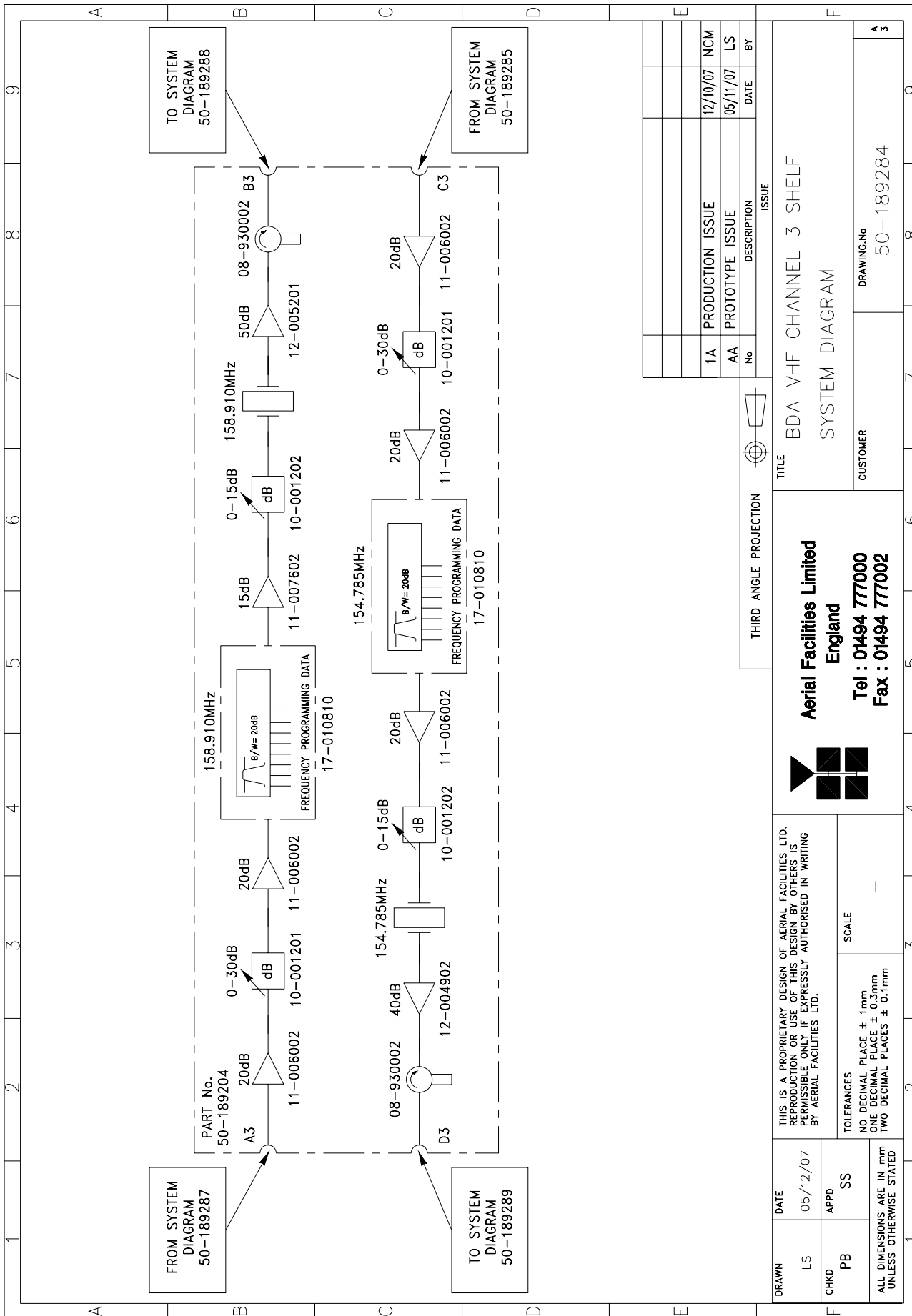

1A	PRODUCTION ISSUE	12/10/07	NCM
AA	PROTOTYPE ISSUE	05/11/07	LS
No	DESCRIPTION	DATE	BY

THIRD ANGLE PROJECTION		
ISSUE		
TITLE BDA VHF CHANNEL 3 SHELF SYSTEM DIAGRAM		
CUSTOMER		DRAWING.No
		50-189284

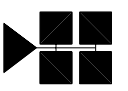
Aerial Facilities Limited
England
Tel : 01494 777000
Fax : 01494 777002

DRAWN	DATE	THIS IS A PROPRIETARY DESIGN OF AERIAL FACILITIES LTD. REPRODUCTION OR USE OF THIS DESIGN BY OTHERS IS PERMISSIBLE ONLY IF EXPRESSLY AUTHORISED IN WRITING BY AERIAL FACILITIES LTD.	
LS	05/12/07	TOLERANCES	SCALE
CHKD	APPD	NO DECIMAL PLACE ± 1mm	—
PB	SS	ONE DECIMAL PLACE ± 0.3mm	
ALL DIMENSIONS ARE IN mm UNLESS OTHERWISE STATED		TWO DECIMAL PLACES ± 0.1mm	

4.5.6. BDA VHF Channel 5 Shelf (50-189206) System diagram

Drawing number 50-189286

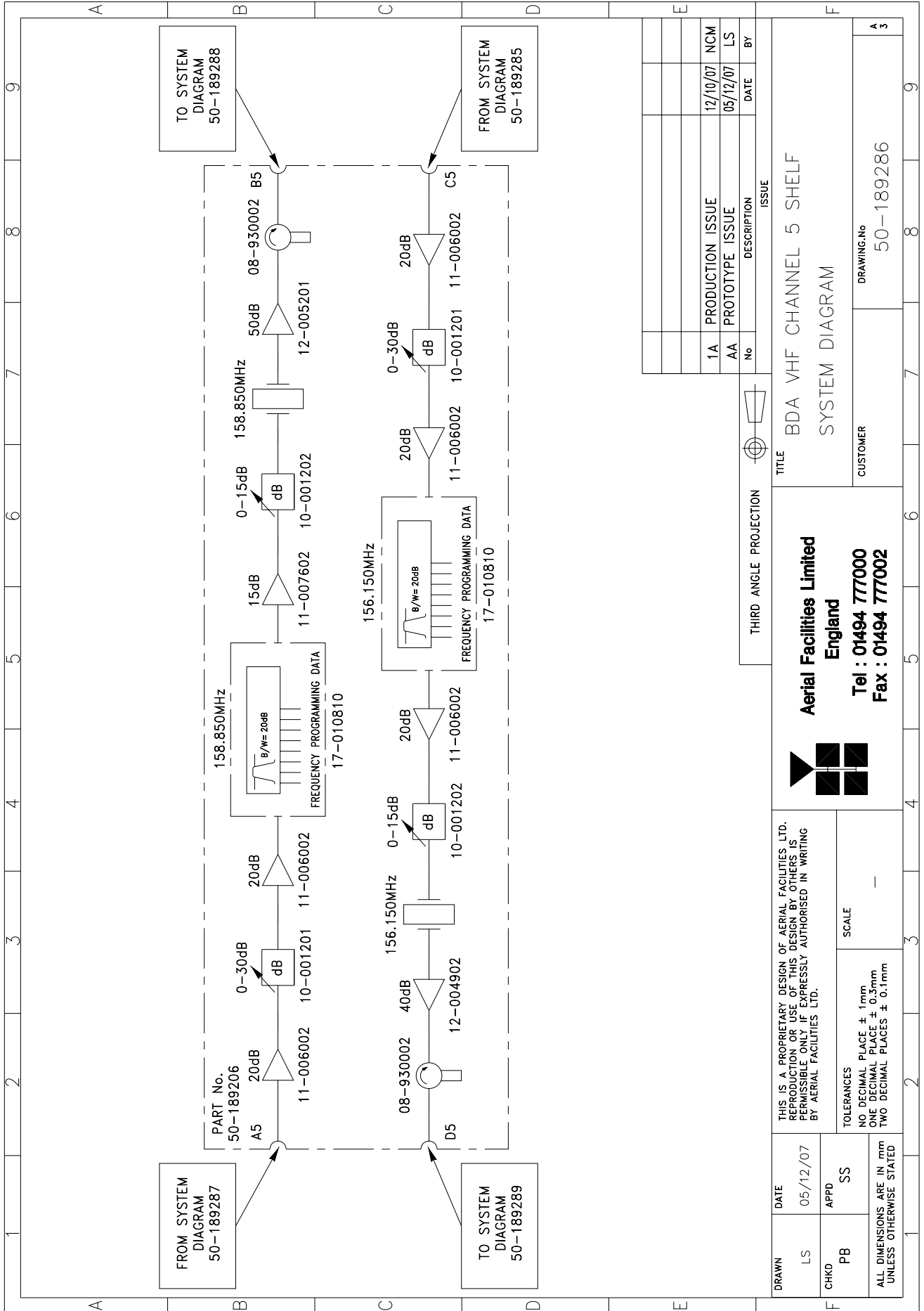

No	DESCRIPTION	DATE	BY
1A	PRODUCTION ISSUE	12/10/07	NCM
AA	PROTOTYPE ISSUE	05/12/07	LS

THIRD ANGLE PROJECTION

<p>Aerial Facilities Limited England Tel : 01494 777000 Fax : 01494 777002</p>	<p>TITLE BDA VHF CHANNEL 5 SHELF SYSTEM DIAGRAM</p>
<p>THIS IS A PROPRIETARY DESIGN OF AERIAL FACILITIES LTD. PERMISSION IS GRANTED FOR REPRODUCTION OF THIS DRAWING FOR THE PURPOSES OF EXPRESSLY AUTHORISED IN WRITING BY AERIAL FACILITIES LTD.</p>	<p>CUSTOMER DRAWING No 50-189286</p>
<p>TOLERANCES NO DECIMAL PLACE ± 1mm ONE DECIMAL PLACE ± 0.3mm TWO DECIMAL PLACES ± 0.1mm UNLESS OTHERWISE STATED</p>	<p>ISSUE</p>
<p>SCALE</p>	<p>DATE</p>
<p>APPD</p>	<p>BY</p>
<p>SS</p>	<p>DATE</p>
<p>PB</p>	<p>BY</p>
<p>LS</p>	<p>DATE</p>
<p>DATE</p>	<p>BY</p>

4.6. BDA VHF UPLINK OUTPUT COMBINER (50-189209)

The Uplink Output Combiner (50-189209) takes the five separate uplink outputs from the Channelised Amplifier shelves and combines them into three signal paths. Channels 3 and 4 are combined by a Hybrid Combiner, Channels 5 and 1 are combined by a second Hybrid Combiner. Channel 2 passes straight through. The three resultant outputs are then fed to the second stage of the cavity filter in rack 3.

4.6.1. BDA VHF Uplink Output Combiner (50-189209) Major Components

Component Part	Component Part Description	Qty Per Assembly
05-000103	Hybrid Combiner	2
19-000822K	2U Rack Mount chassis	1

Top View – lid removed



Close-up of connectors

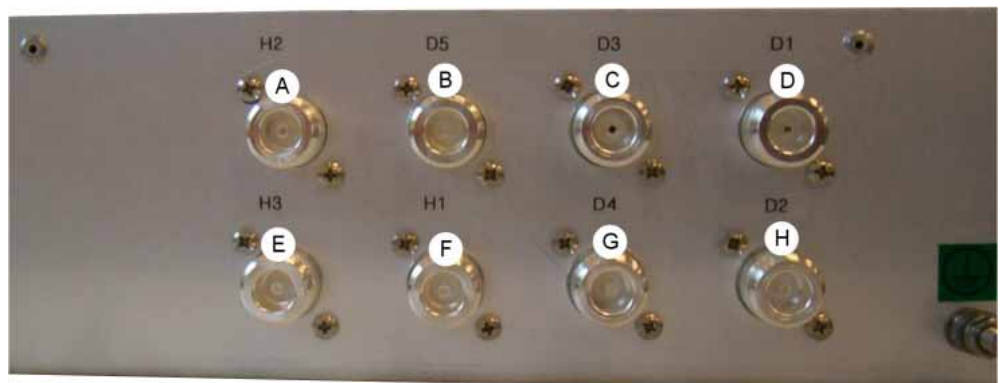

A	Port H2 U/L Channel 2 output
B	Port D5 U/L Channel 5 input
C	Port D3 U/L Channel 3 input
D	Port D1 U/L Channel 1 input
E	Port H3 U/L Channel 1/5 output
F	Port H1 U/L Channel 3/4 output
G	Port D4 U/L Channel 4 input
H	Port D2 U/L Channel 2 input

4.6.2. BDA VHF Uplink Output Combiner (50-189209) System Diagram

Drawing number 50-189289

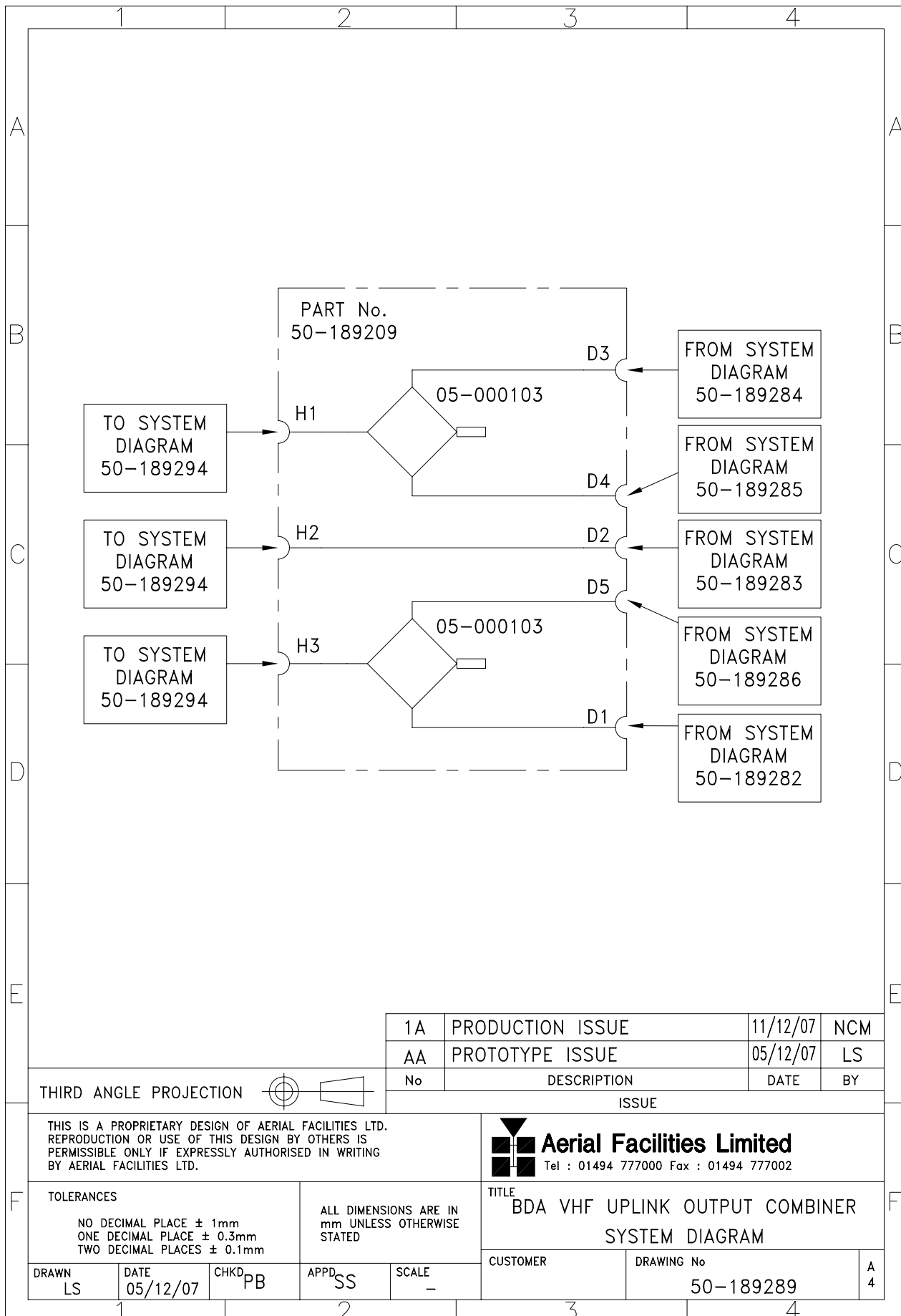

1A	PRODUCTION ISSUE	11/12/07	NCM
AA	PROTOTYPE ISSUE	05/12/07	LS
No	DESCRIPTION	DATE	BY
ISSUE			

THIRD ANGLE PROJECTION

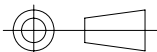

THIS IS A PROPRIETARY DESIGN OF AERIAL FACILITIES LTD.
REPRODUCTION OR USE OF THIS DESIGN BY OTHERS IS
PERMISSIBLE ONLY IF EXPRESSLY AUTHORISED IN WRITING
BY AERIAL FACILITIES LTD.



Aerial Facilities Limited

Tel : 01494 777000 Fax : 01494 777002

TOLERANCES

NO DECIMAL PLACE ± 1mm
ONE DECIMAL PLACE ± 0.3mm
TWO DECIMAL PLACES ± 0.1mm

ALL DIMENSIONS ARE IN
mm UNLESS OTHERWISE
STATED

TITLE

BDA VHF UPLINK OUTPUT COMBINER
SYSTEM DIAGRAM

DRAWN LS	DATE 05/12/07	CHKD PB	APPD SS	SCALE -	CUSTOMER	DRAWING No 50-189289	A 4
-------------	------------------	------------	------------	------------	----------	-------------------------	--------

4.7. BDA VHF DOWNLINK INPUT SPLITTER (50-189207)

Downlink Input Splitter (50-189207) shelf receives Downlink VHF signals from the off-air RX antenna, the signal is split into three paths and each path is then passed through a Bandpass Notch Filter. The outputs of two of the filters are then further divided to produce the five required channels. Each channel then passes through a Crystal Filter before leaving the Input Splitter shelf and going to a dedicated Channelised Amplifier.

4.7.1. BDA VHF Downlink Input Splitter (50-189207) Major Components

Component Part	Component Part Description	Qty Per Assembly
01-003105	Bandpass Notch Filter	3
19-000922K	3U Rack Mount Chassis	1
93-980222	Crystal Filter 154.070MHz	1
93-980223	Crystal Filter 154.190MHz	1
93-980226	Crystal Filter 155.700MHz	1
93-980230	Crystal Filter 158.850MHz	1
93-980231	Crystal Filter 158.910MHz	1

Top View – lid removed



Close-up of connectors

A	Input from RX Antenna
B	Port A4 U/L Channel 4 output
C	Port A2 U/L Channel 2 output
D	Port A5 U/L Channel 5 output
E	Port A3 U/L Channel 3 output
F	Port A1 U/L Channel 1 output

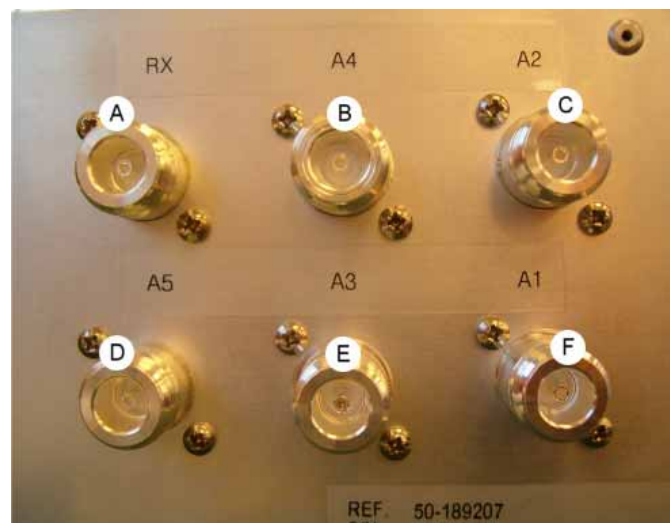

4.7.2. BDA VHF Downlink Input Splitter (50-189207) System Diagram

Drawing number 50-189287

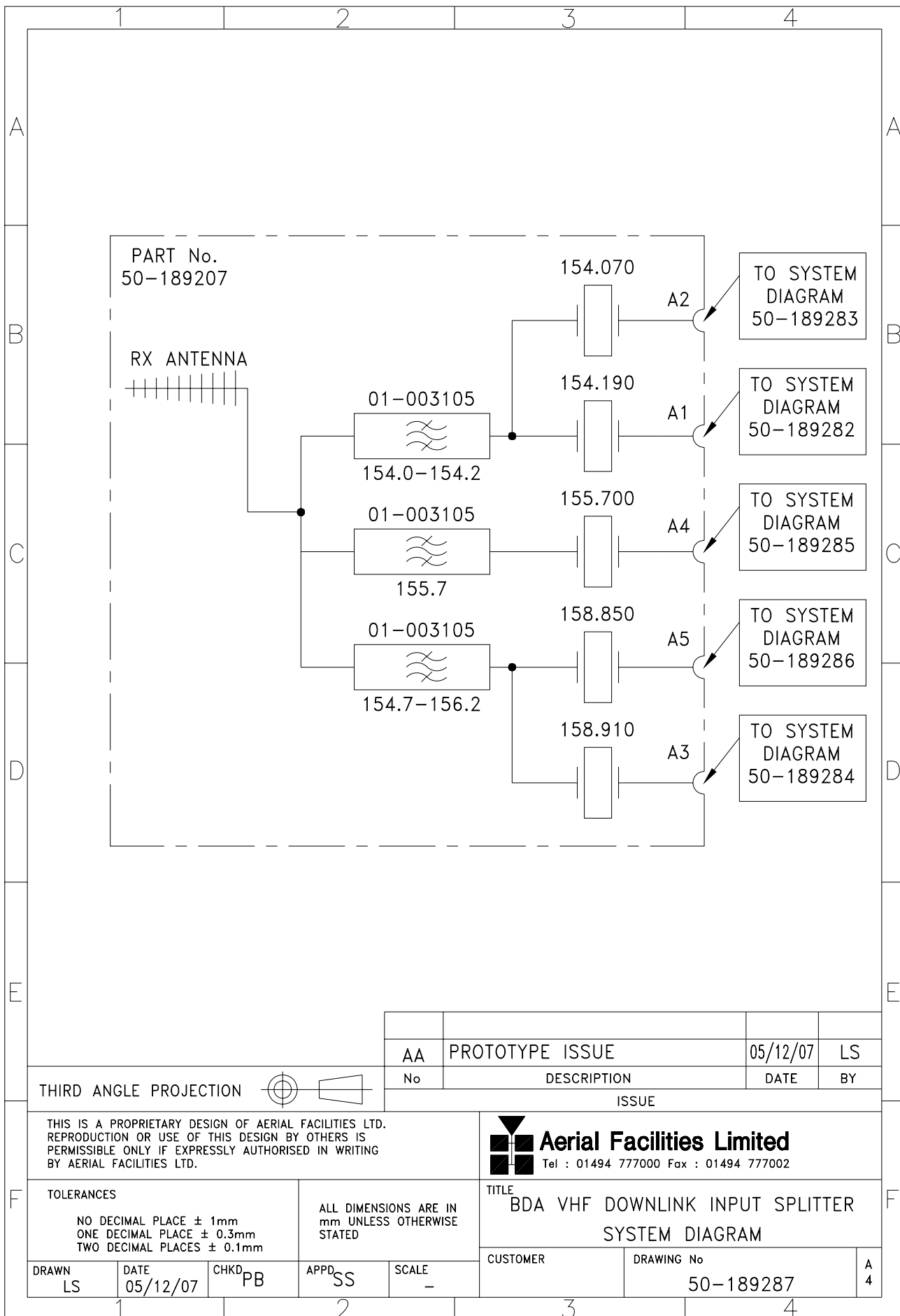

4.8. 24V PSU Shelf (50-146512)

The power supply shelf (50-146512) consists of two, 400Watt 24V DC, O.E.M modules which are commonly supplied from the mains but separately switched. The DC outputs are separately monitored and this data becomes half of the alarm data for the shelf (the two monitor loops are summed to form a single alarm relay contact pair). A pair of low-loss power diodes combine the outputs from the PSU modules in a redundant configuration such that if either module fails, the other supply would still be active but the faulty supply DC LED on the front panel would be extinguished and the alarm loop would be broken.

4.8.1. 24V PSU Shelf (50-146512) Specification

PARAMETER		SPECIFICATION
Shelf dimensions:	Height:	5U
	Width:	19" (482.6mm)
	Depth:	<450mm (excluding connectors & handles)
Temperature range:	operational:	-20°C to +60°C
	storage:	-40°C to +70°C
	Weight:	<10kg
	Humidity:	95% RHNC
	DC Output connectors:	6 x XLR female
	DC Output Voltage:	24V DC (x 6)
	24V DC O/P fuse rating:	10A (x 6)
	Environmental protection:	IP44
	Alarms:	PSU1 & 2 ('D' connector pins 1 & 2)
Finish	Case:	Iridite NCP coat
	Heatsinks:	Black anodised aluminium
	Handles:	Silver anodised aluminium alloy
	Fascia	Painted to RAL7035

4.8.2. 24V PSU Shelf (50-146512) Major Components

Component Part	Component Part Description	Qty Per Assembly
13-003301	Mains Filter Assembly 8 AMP	1
20-001601	12V Relay Board	1
80-008921	PSU 4U Rack mount chassis	1
93-510077	Aluminium Clad Resistor 0R02 50W	2
94-100004	60A DUAL DIODE	1
96-300054	24V 17A PSU 400W	2
96-700034	LED RED 5mm IP67	1
96-700035	LED GREEN 5mm IP67	2
96-920023	5A Circuit Breaker	2

Top View – lid removed

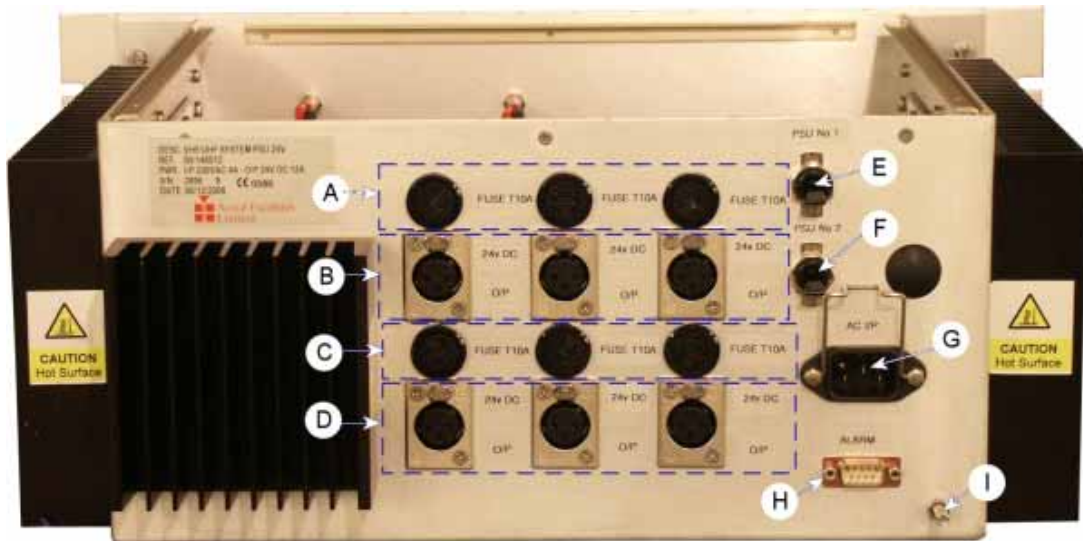
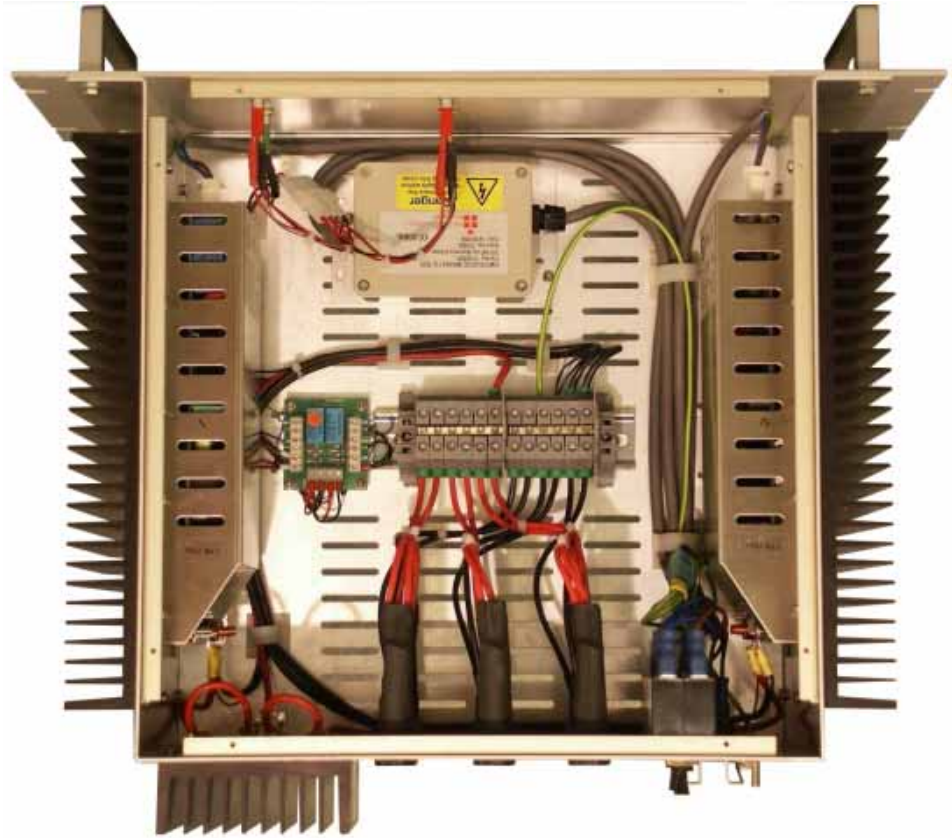

A	Fuses (PSU 1)
B	24V DC Outputs (PSU 1)
C	Fuses (PSU 2)
D	24V DC Outputs (PSU 2)
E	On/Off switch (PSU 1)
F	On/Off switch (PSU 2)
G	AC Input
H	Alarm Output
I	Ground Connection

4.8.2. 24V PSU Shelf (50-146512) System Diagram

Drawing number 60-163486

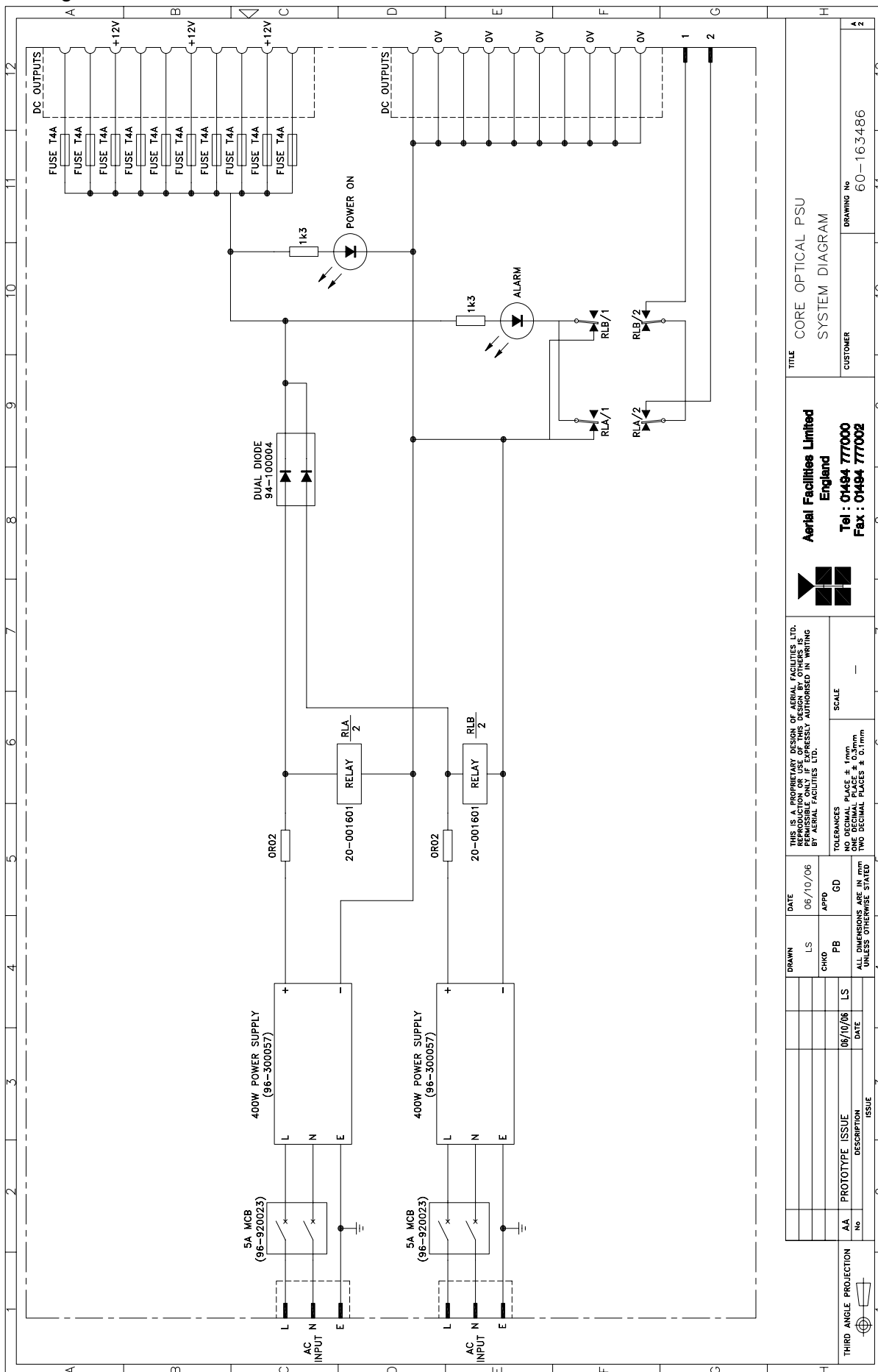

DRAWN		LS	DATE	06/10/06	TITLE		CORE OPTICAL PSU SYSTEM DIAGRAM	
CHKD	PB	APPD	GD		CUSTOMER		DRAWING No 60-163486	
PROTOTYPE ISSUE		06/10/06	SCALE		Aerial Facilities Limited		England	
DESCRIPTION			TOLERANCES		Tel : 01494 777000		Fax : 01494 777002	
ISSUE			NO DECIMAL PLACE ± 1mm		CUSTOMER		DRAWING No 60-163486	
			ONE DECIMAL PLACE ± 0.5mm					
			TWO DECIMAL PLACES ± 0.1mm					
			UNLESS OTHERWISE STATED					

5. BDA VHF SYSTEM RACK 2 (50-189213)

Rack 2, the Downlink cavity combiner takes the three signals from Downlink Output Combiner (50-189208) and passes each of them through a cavity filter stage, the combined D/L channels 1 & 2 are passed through a chain of three cavity filters, D/L channel 4 and the combined D/L channels 3 & 5 are each passed through a chain of two cavity filters. The three signal paths are then combined by means of a critical length harness into a single signal path which is fed into the Hybrid Splitter/Combiner Tray (50-189211) where a Hybrid Splitter splits the signal into two paths, one each for the two LCX feeds.

Rack 2 is a 43U equipment mounting rack (600mm x 600mm) and comprised of the following modules, listed from the top of the rack

Component Part	Component Part Description	Qty Per Assembly
50-189211	Hybrid Splitter/Combiner Tray	1
04-000213	VHF Cavity Resonator	7

Rack Interconnections (see below)

A	Three cavity filter section for combined D/L channels 1 & 2
B	Two cavity filter section for D/L channel 4
C	Two cavity filter section for combined D/L channels 3 & 5
D	Hybrid Splitter/Combiner Tray (50-189211)



Rack interconnections are on the top of the rack rack

E1	D/L Channel 4 from Rack 1
E2	Combined D/L Channel 1 & 2 from Rack 1
E3	Combined D/L Channel 3 & 5 from Rack 1
K1	Combined U/L feed to Rack 3
LCX	Connection to LCX
LCX	Connection to LCX

5.1. BDA VHF System Rack 2 (50-189213) System Diagram

Drawing number 50-189293

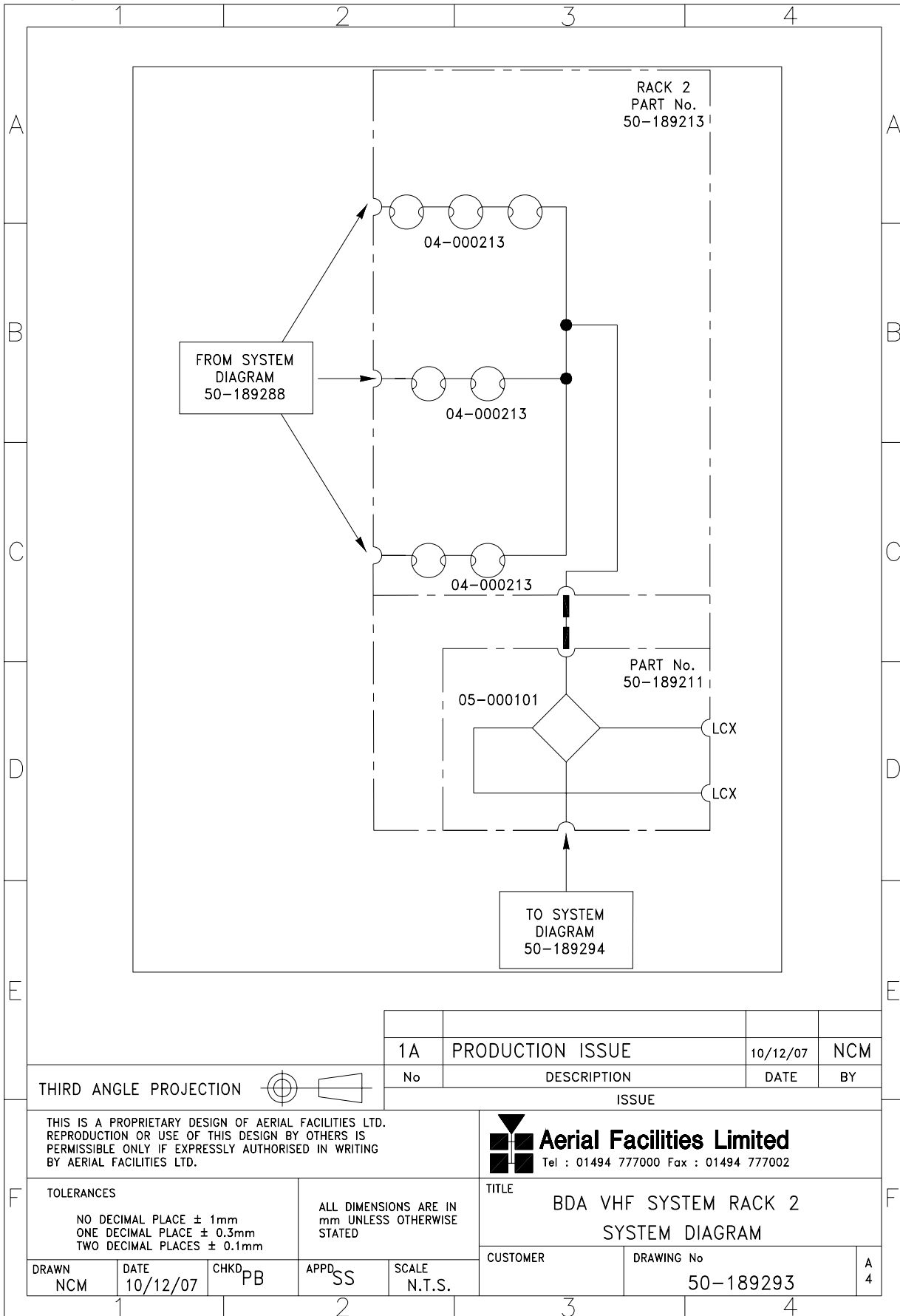

1A	PRODUCTION ISSUE	10/12/07	NCM
No	DESCRIPTION	DATE	BY
ISSUE			

THIRD ANGLE PROJECTION

THIS IS A PROPRIETARY DESIGN OF AERIAL FACILITIES LTD. REPRODUCTION OR USE OF THIS DESIGN BY OTHERS IS PERMISSIBLE ONLY IF EXPRESSLY AUTHORISED IN WRITING BY AERIAL FACILITIES LTD.

Aerial Facilities Limited
Tel : 01494 777000 Fax : 01494 777002

TOLERANCES
NO DECIMAL PLACE ± 1mm
ONE DECIMAL PLACE ± 0.3mm
TWO DECIMAL PLACES ± 0.1mm

ALL DIMENSIONS ARE IN mm UNLESS OTHERWISE STATED

TITLE
BDA VHF SYSTEM RACK 2
SYSTEM DIAGRAM

DRAWN NCM	DATE 10/12/07	CHKD PB	APPD SS	SCALE N.T.S.	CUSTOMER	DRAWING No 50-189293	A 4
--------------	------------------	------------	------------	-----------------	----------	-------------------------	--------

5.2. Hybrid Splitter/Combiner Tray (50-189211)

In the Downlink direction the Hybrid Splitter/Combiner Tray (50-189211) receives the downlink signal from the Downlink Cavity Combiner and splits it into two separate signal paths to provide the two LCX feeds

In the Uplink direction the Hybrid Splitter/Combiner Tray (50-189211) takes the two separate LCX feeds and combines them before passing the signal on to Uplink Input Splitter (50-189210) In rack 1

5.2.1. Hybrid Splitter/Combiner Tray (50-189211) Major Components

Component Part	Component Part Description	Qty Per Assembly
05-000101	Hybrid Splitter/Combiner	1
19-000822K	2U Rack Mount Chassis	1

Top view – lid removed

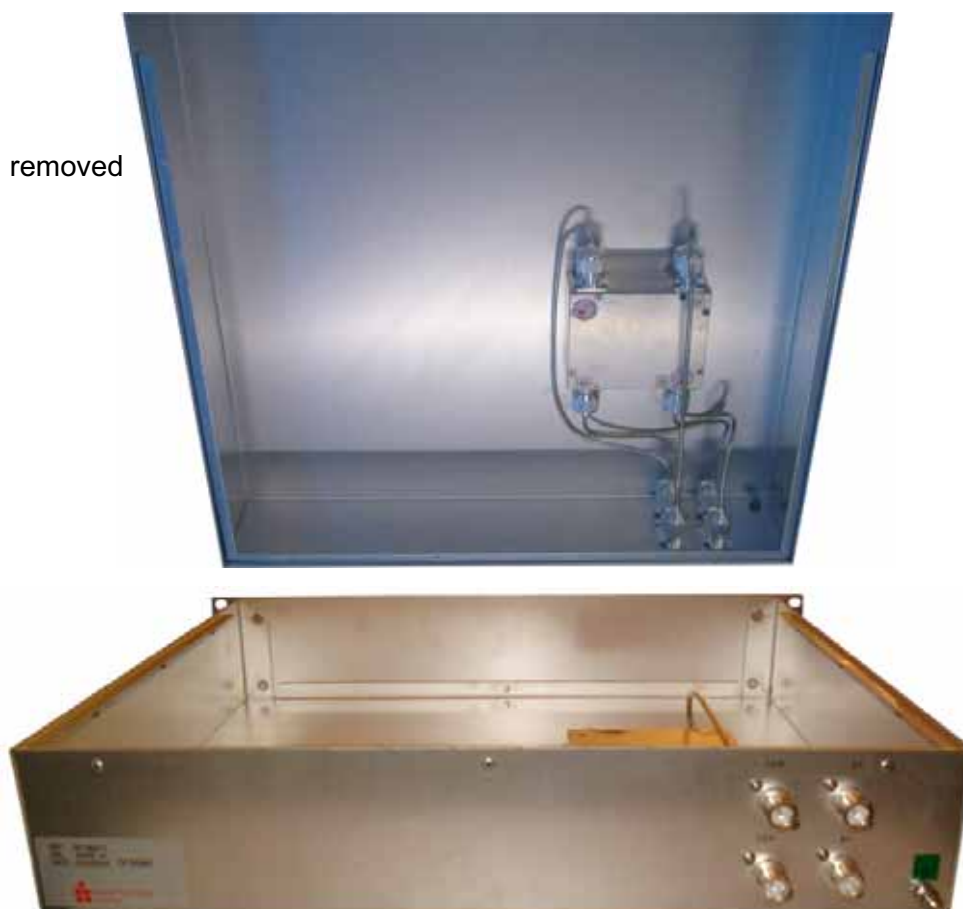

Close-up of connectors

A	LCX 1 Connection
B	Port F1 Combined D/L Input from Cavity Combiner Rack 2
C	LCX 2 Connection
D	Port K1 Combined U/L Output to First stage Cavity Combiner Rack 3

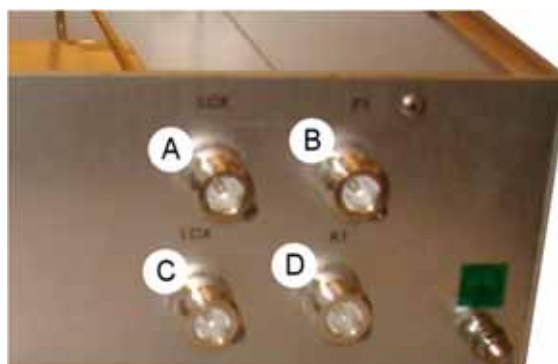

5.2.2. Hybrid Splitter/Combiner Tray (50-189211) System Diagram

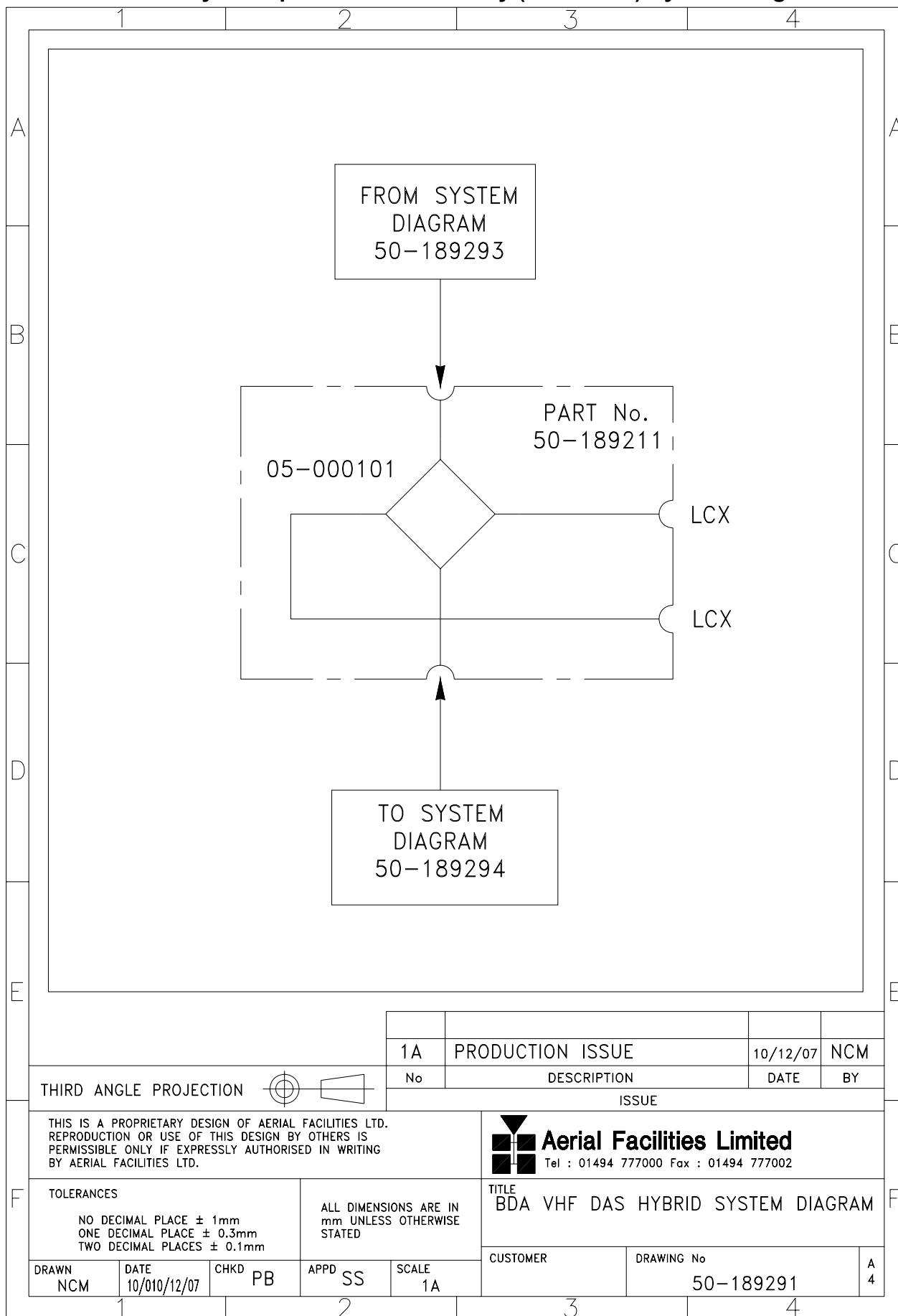

6. BDA VHF SYSTEM RACK 3 (50-189214)

Rack 3, the Uplink Cavity Combiner comprises two stages.

Stage 1 takes the uplink feed from Hybrid Splitter/Combiner Tray (50-189211) in Rack 2 and by means of critical length harnesses splits the signal into three paths, each path is then fed through a chain of two cavity filters before being fed to the Uplink Input Splitter (50-189210) In rack 1

Stage 2 receives the three uplink signals from Uplink Output Combiner (50-189209) and by means of critical length harnesses, combines the signals into a single path which is then routed through a Bandpass Notch Filter before being fed to the TX antenna

Rack 3 is a 43U equipment mounting rack (600mm x 600mm) and comprised of the following modules, listed from the top of the rack

Component Part	Component Part Description	Qty Per Assembly
01-003105	Bandpass Notch Filter	1
04-000213	VHF Cavity Resonator	12

Rack Interconnections (see below)

A	First stage Cavity Combiner
B	Second stage Cavity Combiner
C	Bandpass Notch Filter



Rack interconnections are on the top of the rack rack

Ant	Connection to TX Antenna
K1	Combined U/L feed from rack 2
G1	Combined U/L Channel 3 & 4 to Rack 1
G2	U/L Channel 2 to Rack 1
G3	Combined U/L Channel 1 & 5 to Rack 1
H1	Combined U/L Channel 3 & 4 from Rack 1
H2	U/L Channel 2 from Rack 1
H3	Combined U/L Channel 1 & 5 from Rack 1

6.1. BDA VHF System Rack 3 (50-189214) System Diagram

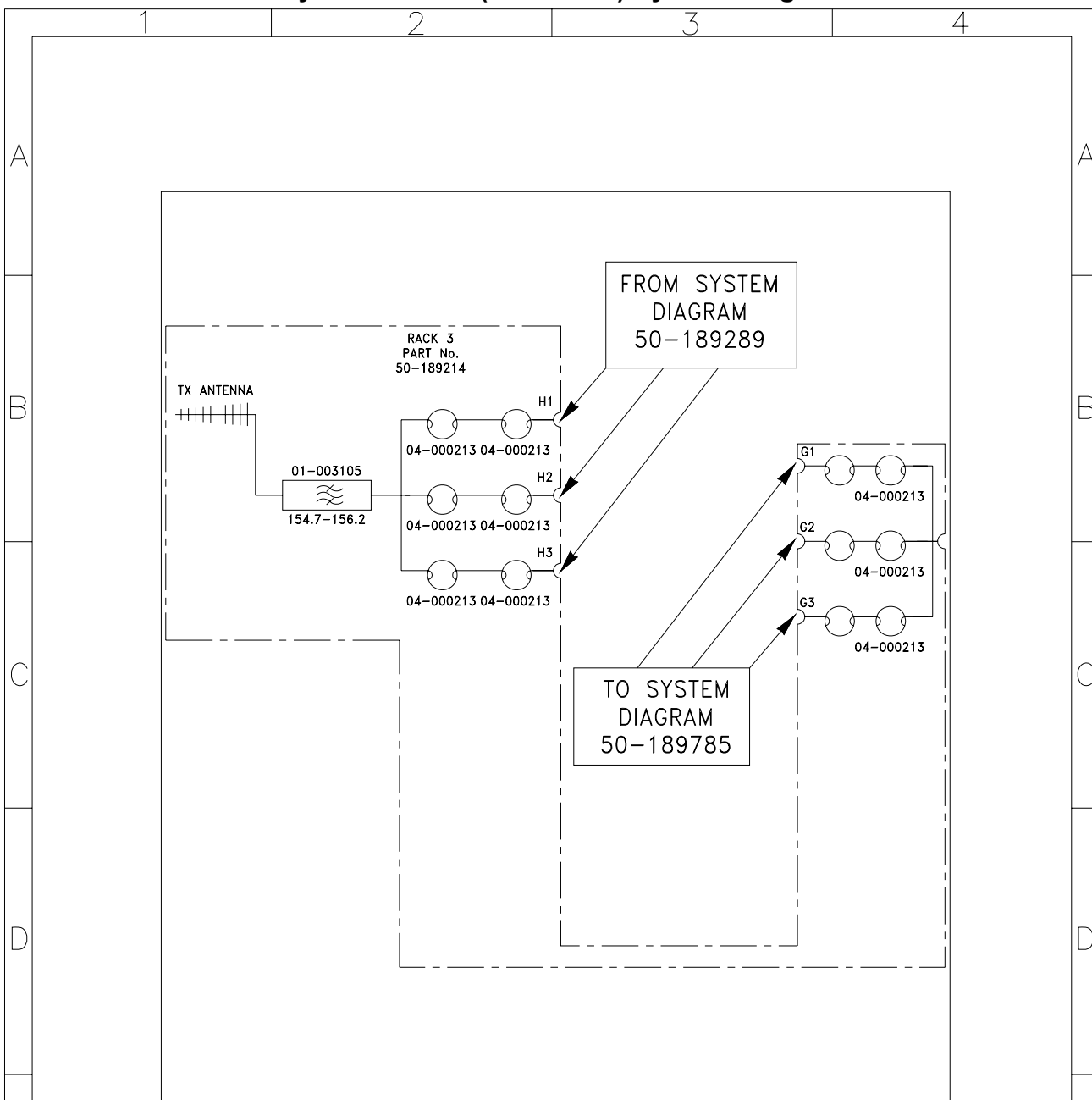

1A		PRODUCTION ISSUE	10/12/07	NCM
No	DESCRIPTION		DATE	BY
ISSUE				

THIRD ANGLE PROJECTION

THIS IS A PROPRIETARY DESIGN OF AERIAL FACILITIES LTD. REPRODUCTION OR USE OF THIS DESIGN BY OTHERS IS PERMISSIBLE ONLY IF EXPRESSLY AUTHORISED IN WRITING BY AERIAL FACILITIES LTD.

Aerial Facilities Limited
Tel : 01494 777000 Fax : 01494 777002

TOLERANCES
NO DECIMAL PLACE ± 1mm
ONE DECIMAL PLACE ± 0.3mm
TWO DECIMAL PLACES ± 0.1mm

ALL DIMENSIONS ARE IN mm UNLESS OTHERWISE STATED

TITLE
**BDA VHF SYSTEM RACK 3
SYSTEM DIAGRAM**

DRAWN NCM	DATE 10/12/07	CHKD PB	APPD SS	SCALE N.T.S.	CUSTOMER	DRAWING No 50-189294	A 4
--------------	------------------	------------	------------	-----------------	----------	-------------------------	--------

7. INSTALLATION

7.1 Initial Installation Record

When this equipment is initially commissioned, please use the equipment set-up record sheet in Appendix B. This will help both the installation personnel and AFL should these figures be needed for future reference or diagnosis.

8. FAULT FINDING & MAINTENANCE

8.1 General Fault Finding Procedures

In the event that the performance of the system is suspect, a methodical and logical approach to the problem will reveal the cause of the difficulty.

Transmissions from the main base stations are passed through the system to the mobile radio equipment; this could be a handheld radio or a transceiver in a vehicle. This path is referred to as the downlink. The return signal path from the mobile radio equipment to the base station is referred to as the uplink.

The first operation is to check the alarms of each of the active units and determine that the power supplies to the equipment are connected and active.

This can be achieved remotely (via CEMS, the RS232 Coverage Enhancement Management System, if fitted), or locally with the front panel LEDs. The green LED on the front panel should be illuminated, while the red alarm indicator should be off.

If an alarm is on, then that individual shelf/module must be isolated and individually tested against the original test specification.

The individual amplifier units have a green LED showing through a hole in their case, which is illuminated if the unit is working correctly.

If an amplifier is suspect, check the DC power supply to the unit. If no other fault is apparent use a spectrum analyser to measure the incoming signal level at the input and then after reconnecting the amplifier input, measure the output level. Consult with the system diagram to determine the expected gain and compare result.

In the event that there are no alarms on and all units appear to be functioning it will be necessary to test the system in a systematic manner to confirm correct operation.

8.2 Downlink

Confirm that there is a signal at the expected frequency and strength from the base station. If this is not present then the fault may lay outside the system. To confirm this, inject a downlink frequency signal from a known source at the master site BTS input and check for output at the remote site feeder output.

If a signal is not received at the output it will be necessary to follow the downlink path through the system to find a point at which the signal is lost. The expected downlink output for the given input can be found in the end-to-end test specification.

8.3 Uplink

Testing the uplink involves a similar procedure to the downlink except that the frequencies used are those transmitted by the mobile equipment.

8.4 Fault repair

Once a faulty component has been identified, a decision must be made on the appropriate course to carry out a repair. A competent engineer can quickly remedy typical faults such as faulty connections or cables. The exceptions to this are cable assemblies connecting bandpass filter assemblies that are manufactured to critical lengths to maintain a 50-ohm system. Care should be taken when replacing cables or connectors to ensure that items are of the correct specification. The repair of component modules such as amplifiers and bandpass filters will not usually be possible in the field, as they frequently require specialist knowledge and test equipment to ensure correct operation. It is recommended that items of this type are replaced with a spare unit and the faulty unit returned to AFL for repair.

8.5 Checking service

Following the repair of any part of the system it is recommended that a full end-to-end test is carried out in accordance with the test specification and that the coverage is checked by survey. It is important to bear in mind that the system includes a radiating cable network and base stations that may be faulty or may have been damaged.

8.6 Service Support

Advice and assistance with maintaining and servicing this system are available by contacting Aerial Facilities Ltd.

8.7 Tools & Test Equipment

The minimum tools and test equipment needed to successfully service this AFL product are as follows:-

Spectrum analyser:	100kHz to 2GHz (Dynamic range = 90dB).
Signal Generator:	30MHz to 2GHz (-120dBm to 0dBm o/p level).
Attenuator:	20dB, 10W, DC-2GHz, (N male – N female).
Test Antenna:	Yagi or dipole for operating frequency.
Digital multi-meter:	Universal Volt-Ohm-Amp meter.
Test cable x 2:	N male – N male, 2M long RG214.
Test cable x 2:	SMA male – N male, 1m long RG223.
Hand tools:	Philips #1&2 tip screwdriver. 3mm flat bladed screwdriver. SMA spanner and torque setter.

8.8 General Maintenance Procedures

Many of the active modules contain semiconductor devices utilising MOS technology, which can be damaged by electrostatic discharge. Correct handling of such modules is mandatory to ensure their long-term reliability.

To prevent damage to a module, it must be withdrawn/inserted with care. The module may have connectors on its underside, which might not be visible to the service operative.

8.9 Module Removal (LNAs, general procedure)

The following general rules should be followed to remove a module:

- 1 Remove power to the unit
- 2 Remove all visible connectors (RF, DC & alarm)
- 3 Release module retaining screws.
- 4 Slowly but firmly, pull the module straight out of its position. Take care not to twist/turn the module during withdrawal. (When the module is loose, care may be needed, as there may be concealed connections underneath).

8.10 Module Replacement (general)

- 1 Carefully align the module into its location then slowly push the module directly straight into its position, taking care not to twist/turn it during insertion.
- 2 Reconnect all connectors, RF, alarm, power etc., (concealed connectors may have to be connected first).
- 3 Replace retaining screws (if any).
- 4 Double-check all connections before applying power.

8.11 Power Amplifiers

- 1) Remove power to the unit. (Switch off at the mains/battery, or remove DC in connector)
- 2) Remove alarm wires from alarm screw terminal block or disconnect multi-way alarm connector.
- 3) Carefully disconnect the RF input and output coaxial connectors (usually SMA)
- 4) If the amplifier to be removed has a heatsink attached, there may be several different ways it can have been assembled. The most commonly used method, is screws through the front of the heatsink to threaded screw holes (or nuts and bolts), into the amplifier within the main case. If the heatsink is mounted on the rear of the main case (e.g., against a wall in the case of wall mounted enclosures), then the fixing method for the heatsink will be from within the case, (otherwise the enclosure would have to be removed from the wall in order to remove the heatsink).

When the heatsink has been removed, the amplifier may be unscrewed from the main casing by its four corner fixings and gently withdrawn.

Fitting a new power amplifier module will be the exact reverse of the above.

Note: Do not forget to apply fresh heatsink compound to the heatsink/main case joint and also between the amplifier and the main case.

8.12 Low Power Amplifier Replacement

Disconnect the mains power supply and disconnect the 24V dc supply connector for the LPA.

Disconnect the RF input and output cables from the LPA.

Disconnect the alarm connector.

Remove the alarm monitoring wires from (D type connector) pins 9 and 10.

Remove the LPA module by removing the four retaining screws, replace with a new LPA module and secure it with the screws.

Connect the RF cables to the LPA input and output connectors. Reconnect the wires to the alarm board connector pins 9 and 10.

Reconnect the DC supply connector and turn the mains switch on.

Note: Tighten SMA connectors using only a dedicated SMA torque spanner. If SMA connectors are over-tightened, irreparable damage will occur. . Do not use adjustable pliers to loosen/tighten SMA connectors.

Also take care not to drop or knock the module as this can damage (or misalign in the case of tuned passive modules) sensitive internal components. Always store the modules in an environmentally friendly location

8.13 Module Transportation

To maintain the operation, performance and reliability of any module it must be stored and transported correctly. Any module not installed in a whole system must be kept in an anti-static bag or container. These bags or containers are normally identified by being pink or black, and are often marked with an ESD label. Any module sent back to AFL for investigation/repair must be so protected. Please contact AFL's quality department before returning a module.

APPENDIX A

A.1. Glossary of Terms used in this document

Repeater or Cell Enhancer	A Radio Frequency (RF) amplifier which can simultaneously amplify and re-broadcast Mobile Station (MS) and Base Transceiver Station (BTS) signals.
Band Selective Repeater	A Cell Enhancer designed for operation on a range of channels within a specified frequency band.
Channel Selective Repeater	A Cell Enhancer, designed for operation on specified channel(s) within a specified frequency band. Channel frequencies may be factory set or on-site programmable.
AC	Alternating Current
AGC	Automatic Gain Control
BBU	Battery Backup Unit
BTS	Base Transceiver Station
CEMS	Coverage Enhanced Management System
C/NR	Carrier-to-Noise Ratio
DC	Direct Current
Downlink (D/L)	RF signals TX from the BTS to the Master Site
FO	Fibre Optic
GND	Ground
ID	Identification Number
LED	Light Emitting Diode
LNA	Low Noise Amplifier
LPA	Low Power Amplifier
MOU	Master Optical Unit
M.S.	Mobile Station
MTBF	Mean Time Between Failures
N/A	Not Applicable
N/C	No Connection
OFR	On Frequency Repeater
OIP3	Output Third Order Intercept Point
P1dB	1dB Compression Point
PA	Power Amplifier
RF	Radio Frequency
RSA	Receiver/Splitter Amplifier
RX	Receiver
S/N	Serial Number
TX	Transmitter
Uplink (U/L)	RF signals transmitted from the MS to the BTS
VSWR	Voltage Standing Wave Ratio
WDM	Wave division multiplex

A.2. Key to Drawing Symbols used in this document

1		2		3		4		5		6		7		8		9																																					
HUBS FIBRE MAIN HUB EXPANSION HUB TAPPER/COUPLER		COUPLERS 10MB COUPLER 6dB DIRECTIONAL COUPLER 10dB DIRECTIONAL COUPLER 6dB DIRECTIONAL COUPLER DIRECTIONAL COUPLER CROSS BAND COUPLER		CABLES 8 FIBRE OPTIC CABLE/LINK 24 FIBRE OPTIC CABLE/LINK JUMPER CABLE 1/2" RADIATING CABLE CAT 5 CABLE CO-AX CABLE 1/2" DIA CO-AX CABLE 7/8" DIA		SPLITTERS HYBRID SPLITTER SPLITTER		ANTENNAS OMNI ANTENNA YAGI ANTENNA FLAT PLATE ANTENNA (MOUNTED AT HIGH LEVEL) DIRECTIONAL ANTENNA ANTENNA REMOTE ANTENNA UNIT PANEL ANTENNA BLADE ANTENNA		MISC BASE TRANSCEIVER STATION CHANNEL MODULE FIBRE-OPTIC MODULATOR FIBRE-OPTIC DEMODULATOR PLUG & SOCKET SOCKET PLUG FIBRE OPTIC CONNECTOR FC/APC		MISC BAND PASS FILTER CAVITY RESONATOR NOTCH FILTER ISOLATOR HYBRID COMBINER EARTH STUD LEEKY FEEDER R.S.A. <small>Outputs to receivers</small>		MISC AMPLIFIER ATTENUATOR (VARIABLE) ATTENUATOR (FIXED) A.G.C. MONITORING CONTROLLER MODEM BIDIRECTIONAL AMPLIFIER (CELL ENHANCER) DUMMY LOAD LOCAL OSCILLATOR		MISC AC TO DC PSU DC TO DC CONVERTER FUSE RELAY N.O. (CLEAR CONTACT) N.C. (FILLED CONTACT)		SIGNAL KEY • = READING POSITION 602 = BCCH (BROADCAST CONTROL CHANNEL) 22 = BSIC (BASIC SITE IDENTITY CODE) -82 = ACCEPTABLE SIGNAL LEVEL (dbm) -83 = BELOW ACCEPTABLE SIGNAL LEVEL (dbm) -72 = ACCEPTABLE SIGNAL LEVEL (dbm) -73 = BELOW ACCEPTABLE SIGNAL LEVEL (dbm)		STANDARD EXCEPT FOR AIRPORTS (SEE BELOW) STANDARD FOR ALL AIRPORTS		<table border="1"> <tr> <th>No</th> <th>DESCRIPTION</th> <th>DATE</th> <th>BY</th> </tr> <tr> <td>2B</td> <td>TEXT CORRECTION</td> <td>28/07/04</td> <td>PL</td> </tr> <tr> <td>2A</td> <td>ECN3165</td> <td>26/01/04</td> <td>PL</td> </tr> <tr> <td>1A</td> <td>BLADE ANTENNA ADDED</td> <td>21/06/00</td> <td>PL</td> </tr> <tr> <td>AA</td> <td>ORIGINAL</td> <td>23/05/00</td> <td>PL</td> </tr> </table>		No	DESCRIPTION	DATE	BY	2B	TEXT CORRECTION	28/07/04	PL	2A	ECN3165	26/01/04	PL	1A	BLADE ANTENNA ADDED	21/06/00	PL	AA	ORIGINAL	23/05/00	PL	THIRD ANGLE PROJECTION 		<table border="1"> <tr> <th colspan="2">ISSUE</th> </tr> <tr> <td>No</td> <td>DESCRIPTION</td> </tr> <tr> <td>DATE</td> <td>BY</td> </tr> </table>		ISSUE		No	DESCRIPTION	DATE	BY
No	DESCRIPTION	DATE	BY																																																		
2B	TEXT CORRECTION	28/07/04	PL																																																		
2A	ECN3165	26/01/04	PL																																																		
1A	BLADE ANTENNA ADDED	21/06/00	PL																																																		
AA	ORIGINAL	23/05/00	PL																																																		
ISSUE																																																					
No	DESCRIPTION																																																				
DATE	BY																																																				
DRAWN PL CHKD MB		DATE 10/05/00 APPD GD		TITLE AFL - STANDARD SYMBOLS		CUSTOMER Aerial Facilities Limited England Tel : 01494 777000 Fax : 01494 777002		SCALE NTS		DRAWING No 90-000001		ISSUE DATE BY																																									
1		2		3		4		5		6		7		8		9																																					

A.3. EC Declaration of Conformity



In accordance with BS EN ISO/IEC 17050-1&-2:2004

Aerial Facilities Limited
Aerial House
Asheridge Road
Chesham
Buckinghamshire HP5 2QD
United Kingdom

C E0086

DECLARES, UNDER OUR SOLE RESPONSIBILITY THAT THE FOLLOWING PRODUCT:

PRODUCT PART NO[S] 50-189201
PRODUCT DESCRIPTION 5 Channel VHF System 80dB

IN ACCORDANCE WITH THE FOLLOWING DIRECTIVES:

1999/5/EC The Radio & Telecommunications Terminal Equipment Directive Annex V
and its amending directives

HAS BEEN DESIGNED AND MANUFACTURED TO THE FOLLOWING STANDARD[S]
OR OTHER NORMATIVE DOCUMENT[S]:

BS EN 60950 Information technology equipment.
Safety. General requirements

ETS EN 301 489-1 EMC standard for radio equipment and services.
Part 1. Common technical requirements

I hereby declare that the equipment named above has been designed to comply with the relevant sections of the above referenced specifications. The unit complies with all essential requirements of the Directives.

SIGNED

A handwritten signature in black ink, appearing to read "B S Barton".

B S BARTON
TECHNICAL DIRECTOR

DATE: 22/11/2007

A.4. Amendment List Record Sheet

Issue No.	Date	Incorporated by	Page Nos. Amended	Reason for new issue
A	05/12/2007	AJS		Draft
1	21/12/2007	AJS		First Issue

Document Ref. 50-189201HBK

APPENDIX B

Initial Equipment Set-Up Calculations

General Information			
Site Name:		Client Name:	
Date:		AFL Equip. Model No.	

Antenna Systems				
	Model	Gain	Azimuth	Comments
A - Service Antenna				
B – Donor Antenna				
	Type	Loss	Length	Comments
C – Service Feeder				
D – Donor Feeder				

Initial Parameters	
E – CE Output Power	dBm
F – Antenna Isolation	dB
G – Input signal level from donor BTS	dBm
Operating Voltage	V

Downlink Calculations		
Parameter	Comments	Value
Input signal level (G)		dBm
CE max. o/p power (E)		dBm
Gain setting	E - G	dB
Isolation required	(Gain + 10dB)	dB
Service antenna gain (A)		dB
Service antenna feeder loss (C)		dB
Effective radiated power (ERP)	E+A-C	dBm
Attenuator setting	CE gain-gain setting	dB

If the input signal level in the uplink path is known and steady, use the following calculation table to determine the gain setting. If the CE features Automatic Gain Control the attenuator should be set to zero and if not, then the attenuation setting for both uplink and downlink should be similar.

Uplink Calculations		
Parameter	Comments	Value
Input signal level		dBm
CE max. o/p power (E)		dBm
Gain setting		dB
Required isolation		dB
Donor antenna gain (B)		dB
Donor antenna feeder loss (D)		dB
Effective radiated power (ERP)	E+B-D	dBm
Attenuator setting	(CE gain-gain setting)	dB