

4.3. In-Line BDA Rack Mount 80-301406 Illustrations

4.3.1. Rack 1 Front View

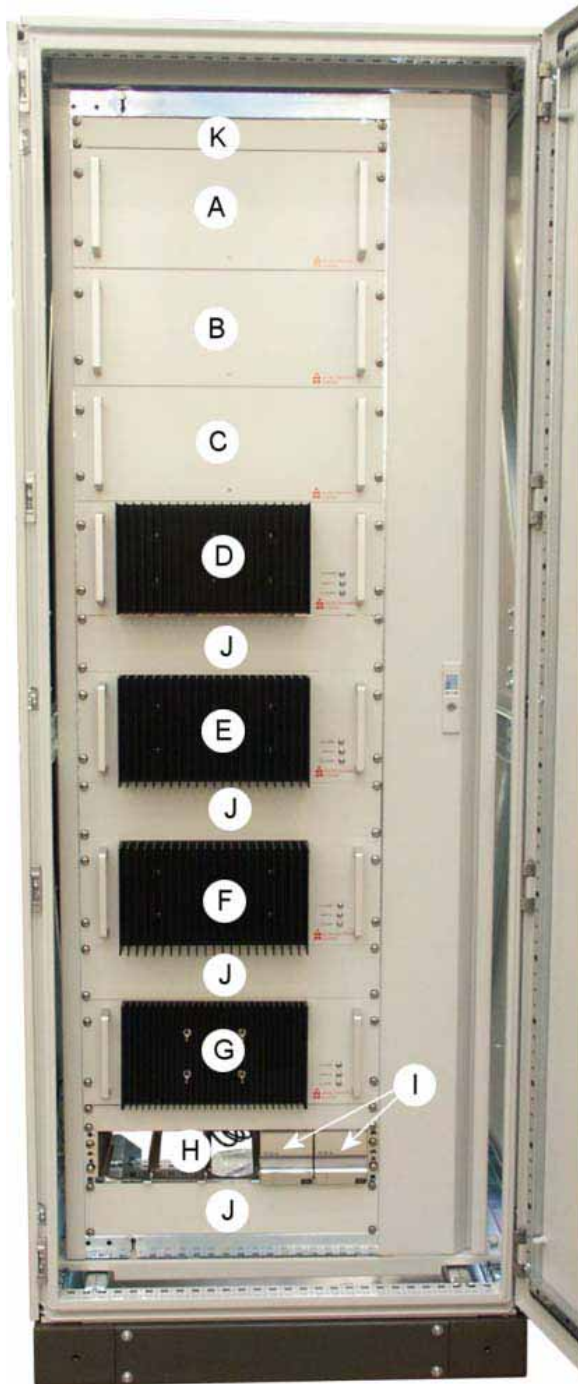

A	Downlink Input Shelf 80-301407
B	Uplink Input Shelf 80-301407
C	Uplink Output Shelf 80-301407
D	UHF Highband Amplifier Shelf 80-301410
E	UHF Midband Amplifier Shelf 80-301410
F	UHF Lowband Amplifier Shelf 80-301410
G	VHF Amplifier Shelf 80-301409
H	PSU Shelf
I	PSU Modules
J	2U Blanking Panel
K	1U Blanking panel

4.3.2. Rack 1 Rear View

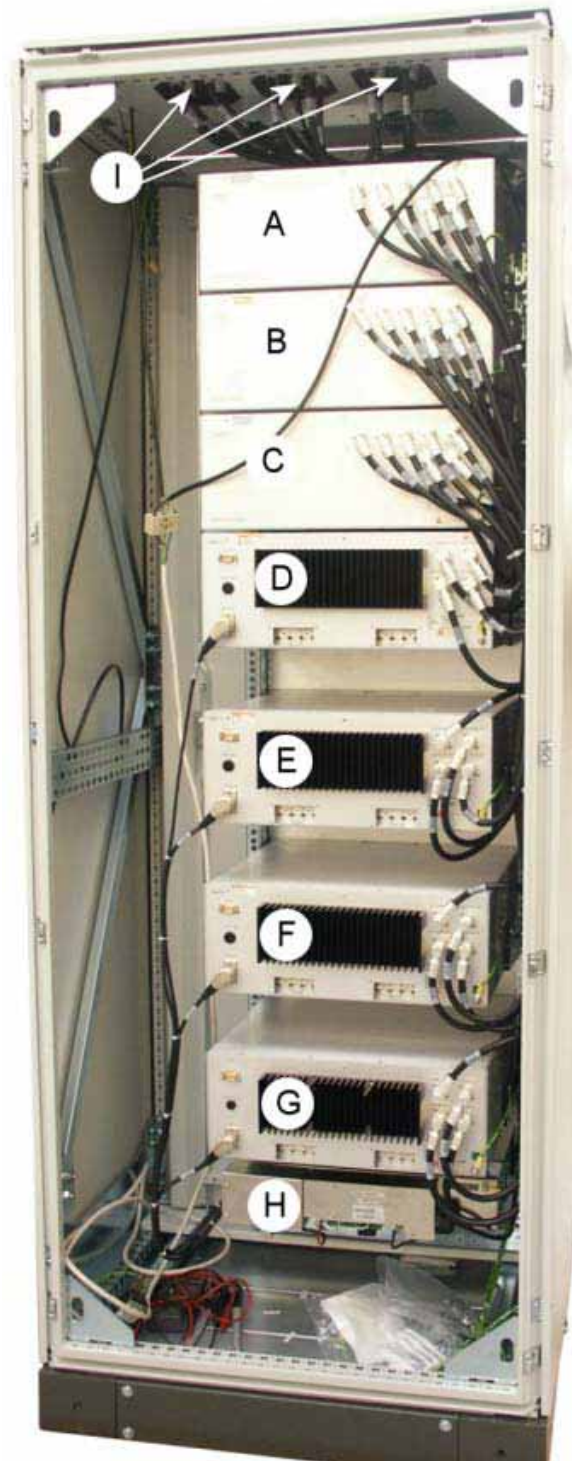

A	Downlink Input Shelf 80-301407
B	Uplink Input Shelf 80-301407
C	Uplink Output Shelf 80-301407
D	UHF Highband Amplifier Shelf 80-301410
E	UHF Midband Amplifier Shelf 80-301410
F	UHF Lowband Amplifier Shelf 80-301410
G	VHF Amplifier Shelf 80-301409
H	PSU Shelf
I	Rack Interconnections

4.3.3. Rack 2 Front View



A	Downlink Output Shelf 80-301408
B	800MHz Amplifier Shelf 80-301411
C	4U Blanking panel
D	1U Blanking panel

4.3.4. Rack 2 Rear View

Top part of rack only

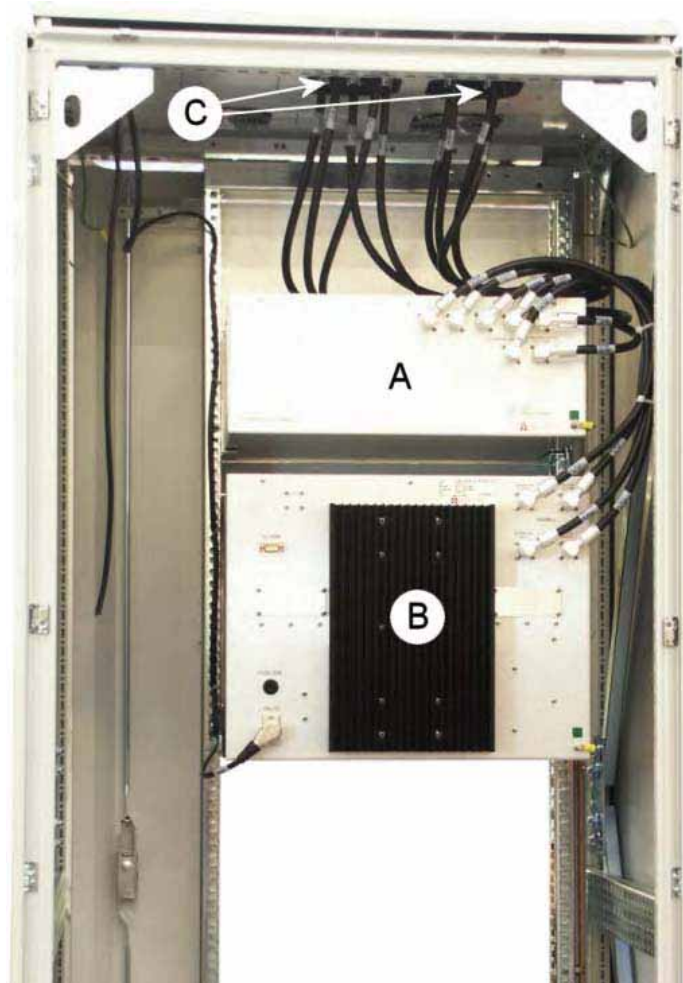

A	Downlink Output Shelf 80-301408
B	800MHz Amplifier Shelf 80-301411
C	Rack Interconnections

4.3.5. Rack 1 Top View

Rack 1
Front of Rack

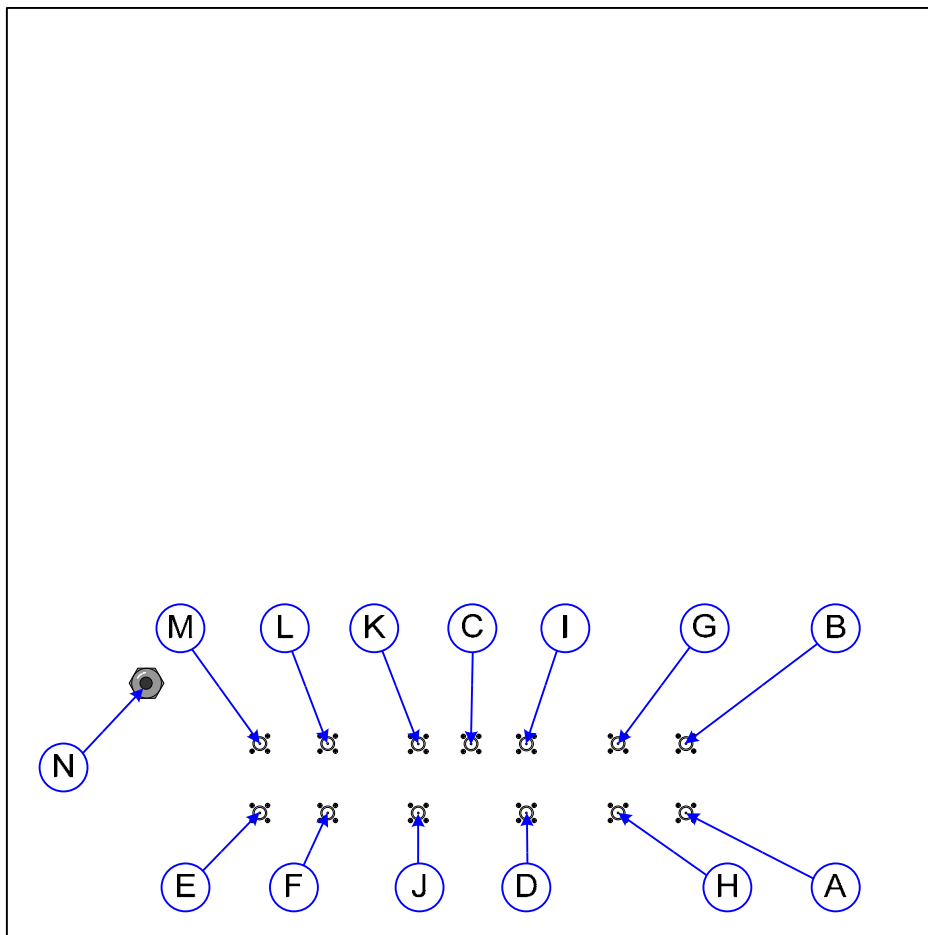

Rear of Rack

A	U/L I/P "J"
B	U/L I/P
C	D/L I/P
D	U/L O/P
E	UHF HIGH D/P O/P
F	UHF MID D/L O/P
G	D/L I/P TEST PORT
H	U/L I/P TEST PORT
I	D/L I/P "A"
J	U/L O/P TEST PORT
K	U/L O/P "C"
L	UHF LOW D/L O/P
M	VHF D/L O/P
N	CABLE GLAND FOR ELECTRICAL WIRING

4.3.6. Rack 2 Top View

Rack 2
Front of Rack

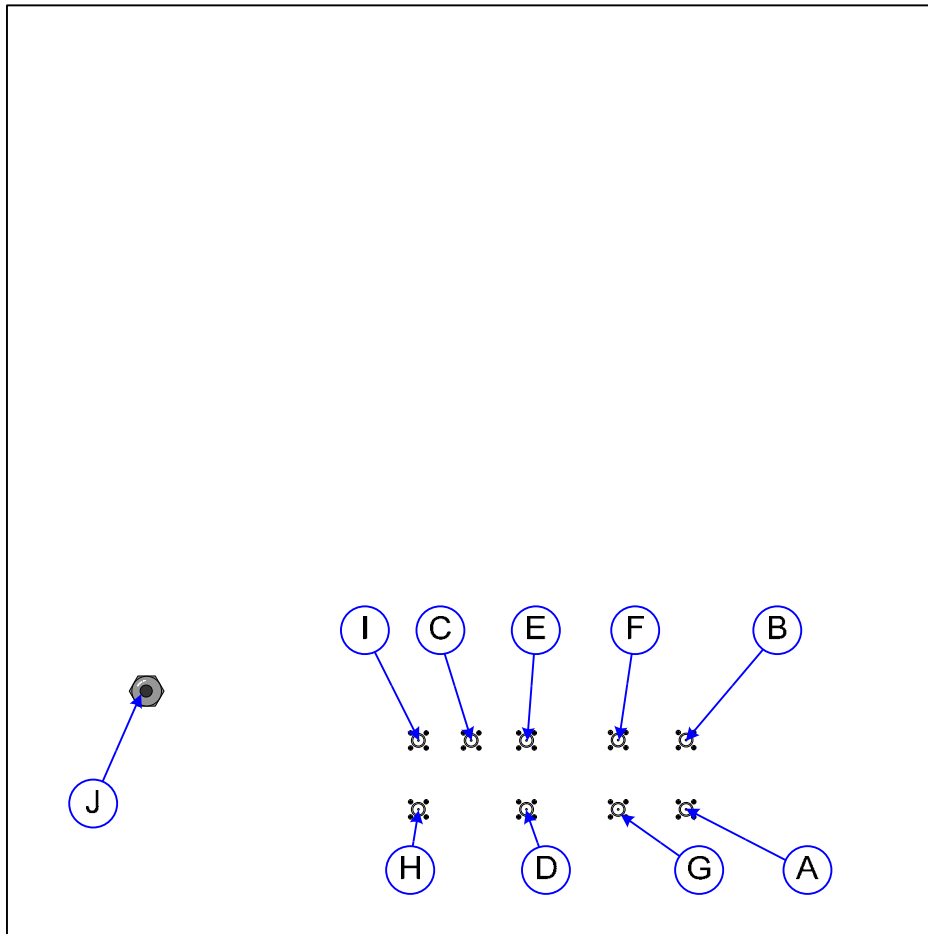

Rear of Rack

A	D/L O/P "D"
B	D/L O/P "B"
C	D/L I/P
D	D/L O/P
E	U/L I/P
F	D/L O/P "C"
G	U/L O/P
H	D/L O/P TEST PORT
I	D/L O/P "A"
J	CABLE GLAND FOR ELECTRICAL WIRING

4.4. In-Line BDA Rack Mount 80-301401 List of Major Components

Section	Component Part	Component Part Description	Qty Per Assembly
4.5.	80-301407	Downlink Input Shelf	1
4.6.	80-301408	Downlink Output Shelf	1
4.7.	80-301407	Uplink Input Shelf	1
4.8.	80-301407	Uplink Output Shelf	1
4.9.	80-301409	VHF Amplifier Shelf	1
4.10.	80-301410	UHF Lowband Amplifier Shelf	1
4.11.	80-301410	UHF Midband Amplifier Shelf	1
4.12.	80-301410	UHF Highband Amplifier Shelf	1
4.13.	80-301411	800MHz Amplifier Shelf	1
4.14	96-300064	PSU	2

4.5. Downlink Input Shelf 80-301407

Downlink Input Shelf 80-301407 is part of the main Splitter/Combiner assembly. Signals are received from the radiating cable and are then split into their various separate paths before being amplified by external band specific amplifiers. The unit is housed in a 4U, 19" rack mount case which is mounted in Rack 1.

Downlink signals are received at the port labelled "DOWNLINK INPUT" (Annotated A in the picture in section 4.5.4.1.) and there is a 30dB test port labelled "DOWNLINK INPUT TEST PORT" (B in section 4.5.4.1.).

Ports labelled 1 to 5 (C to G in section 4.5.4.1.) are the Downlink outputs to the amplification stages.

Downlink Input Shelf 80-301407 also incorporates bandpass filtering for the three UHF bands, the filters are placed in the RF path before the outputs to the external amplification stages.

4.5.1. Downlink Input Shelf 80-301407 System Schematic

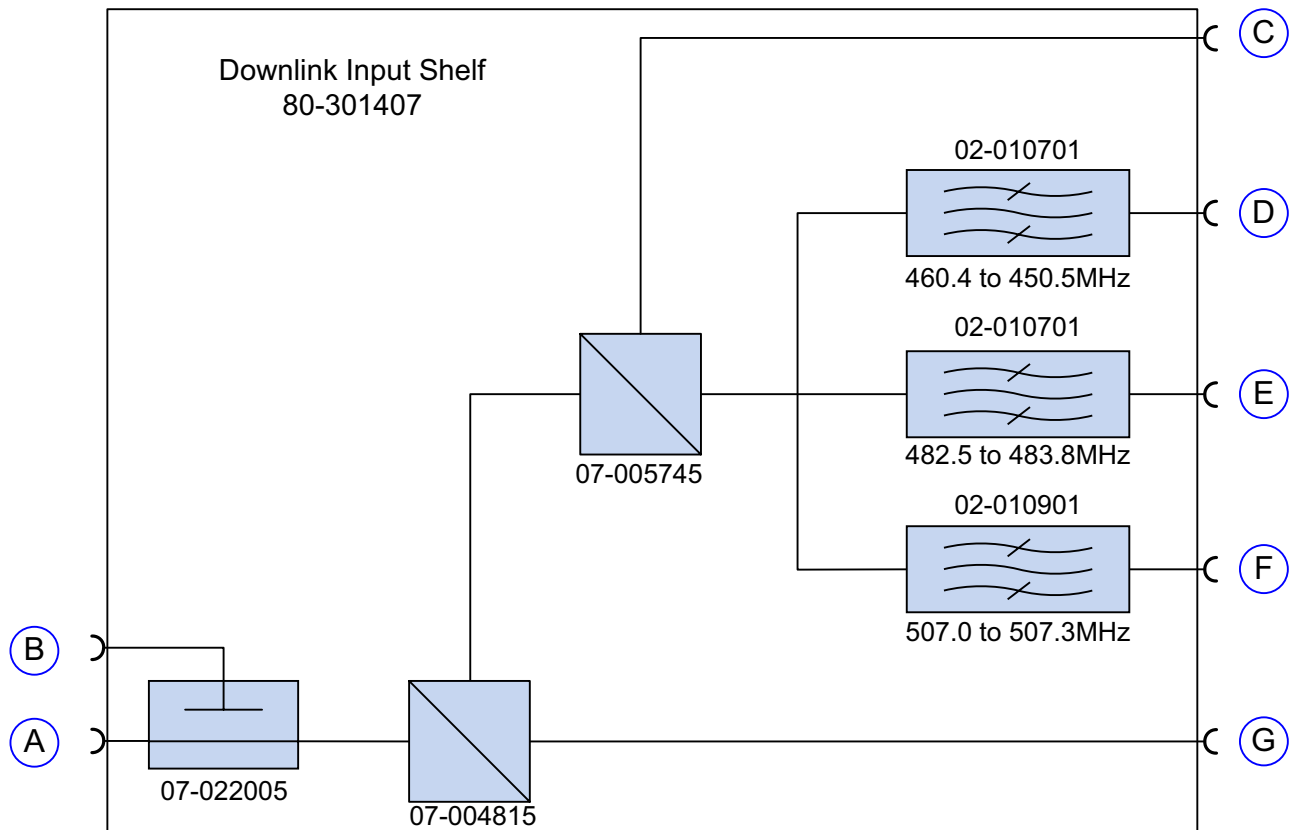

A	Downlink Input from leaky Feeder
B	Downlink Input Test Port (30dB Tap)
C	Port 1. Downlink VHF Output to VHF Amplifier Shelf 80-301409
D	Port 2. Downlink UHF Lowband Output to UHF Lowband Amplifier Shelf 80-301410
E	Port 3. Downlink UHF Midband Output to UHF Midband Amplifier Shelf 80-301410
F	Port 4. Downlink UHF Highband Output to UHF Highband Amplifier Shelf 80-301410
G	Port 5. Downlink 800MHz Output to 800MHz Amplifier Shelf 80-301411

4.5.2. Downlink Input Shelf 80-301407 Outline Drawing

Drawing Number 80-301497

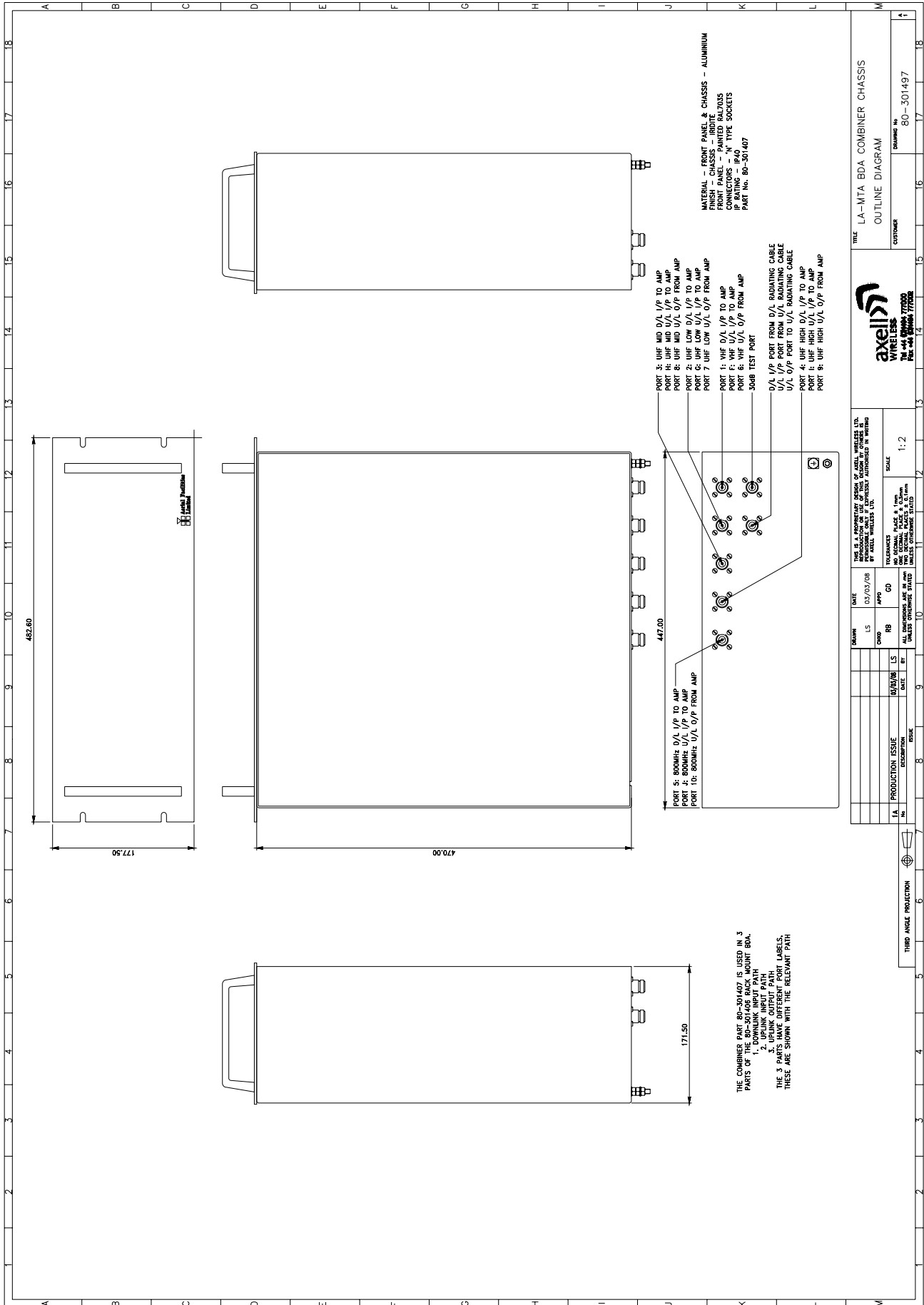

Drawing also applies to Uplink Input Shelf 80-301407 and Uplink Output Shelf 80-301407

4.5.3. Downlink Input Shelf 80-301407 Specification

PARAMETER	SPECIFICATION
Insertion Loss from Downlink Input port to port indicated	
VHF Band to port 1	< 1.0dB at 154.0 – 161.3MHz
UHF Low Band to port 2	< 3.5dB at 460.4 – 460.5MHz
UHF Mid Band to port 3	< 3.5dB at 482.5 -483.8MHz
UHF High Band to port 4	< 4.0dB at 507.0 – 507.3MHz
800MHz Band to port 5	< 1.0dB at 856.0 – 861.0MHz
Insertion Loss from port indicated to Downlink Input test port	
VHF Band	30dB at 154.0 – 161.3MHz
UHF Low Band	30dB at 460.4 – 460.5MHz
UHF Mid Band	30dB at 482.5 – 483.8MHz
UHF High Band	30dB at 507.0 – 507.3MHz
800MHz Band	30dB at 856.0 – 861.0MHz

4.5.4. Downlink Input Shelf 80-301407 Illustrations

4.5.4.1. Rear View

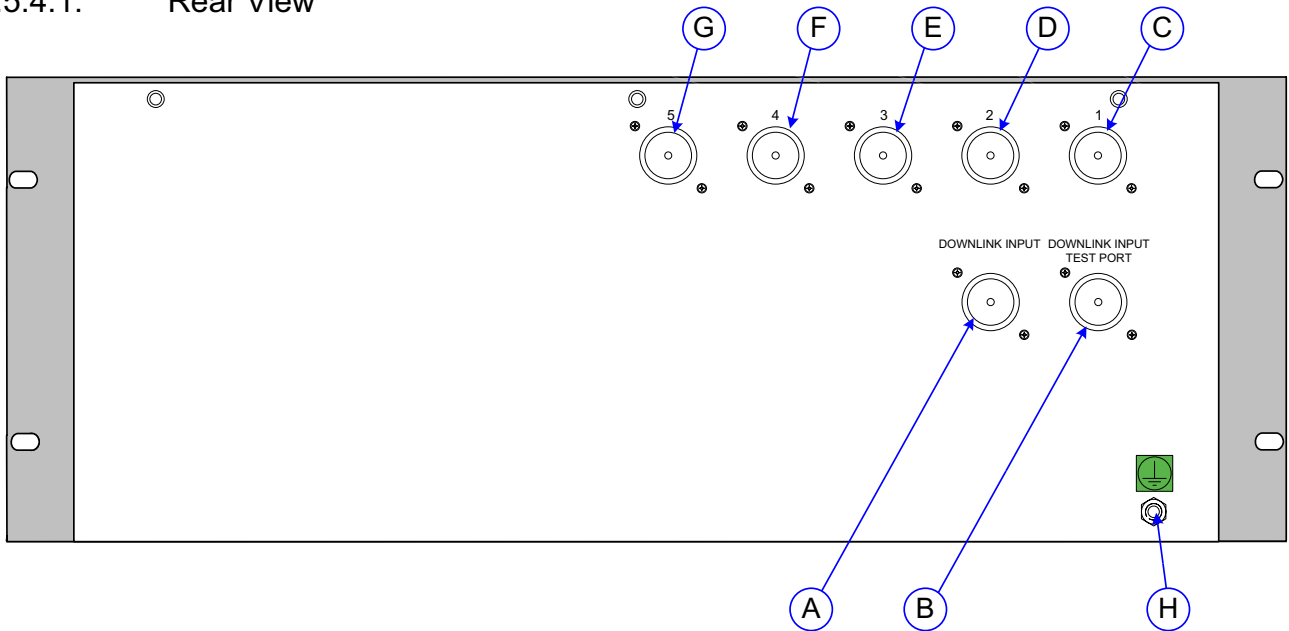

A	Downlink Input from Radiating Cable
B	Downlink Input Test Port (30dB Tap)
C	Port 1. Downlink VHF Output to VHF Amplifier Shelf 80-301409
D	Port 2. Downlink UHF Lowband Output to UHF Lowband Amplifier Shelf 80-301410
E	Port 3. Downlink UHF Midband Output to UHF Midband Amplifier Shelf 80-301410
F	Port 4. Downlink UHF Highband Output to UHF Highband Amplifier Shelf 80-301410
G	Port 5. Downlink 800MHz Output to 800MHz Amplifier Shelf 80-301411
H	Earth Connection

4.5.5. Downlink Input Shelf 80-301407 Major Sub Components

section	Component Part	Component Part Description	Qty Per Assembly
4.5.5.1.	02-010701	Bandpass Filter	2
4.5.5.2.	02-010901	Bandpass Filter	1
4.5.5.3.	07-004815	Crossband Splitter/Coupler 550/800MHz	1
4.5.5.4.	07-005754	Crossband Splitter/Coupler VHF/UHF	1
4.5.5.5.	07-022005	30dB Bi-Directional Coupler	1

4.5.5.1. Bandpass Filter (02-010701)

The bandpass filters are multi-section designs with a bandwidth dependent upon the passband frequencies, (both tuned to customer requirements). The response shape is basically Chebyshev with a passband design ripple of 0.1dB. The filters are of combline design, and are carefully aligned during manufacture in order to optimise the insertion loss, VSWR and intermodulation characteristics of the unit. The tuned elements are silver-plated to reduce surface ohmic losses and maintain a good VSWR figure and 50Ω load at the input and output ports.

Being passive devices, the bandpass filters should have an extremely long operational life and require no maintenance. Should a filter be suspect, it is usually most time efficient to replace the module rather than attempt repair or re-tuning.

02-010701 Specification

PARAMETER			SPECIFICATION
Passband Frequency	UHF Low	Downlink	460.4 to 460.5 MHz
	UHF Mid	Downlink	482.5 to 483.8 MHz
Bandwidth	UHF Low		0.1 MHz
	UHF Mid		1.3 MHz
Number of sections			5
Insertion loss			2.5 dB (typical)
VSWR			better than 1.2:1
Connectors			SMA
Power Handling			100W max
Temperature range	operation		-20°C to +60°C
	storage		-40°C to +70°C
Weight			3 kg (typical)

4.5.5.2. Bandpass Filter 02-010901

Bandpass Filter 02-010901 is a multi-section design with a bandwidth dependent upon the passband frequencies, (both tuned to customer requirements). The response shape is basically Chebyshev with a passband design ripple of 0.1dB. The filters are of helical & combline design respectively, and are carefully aligned during manufacture in order to optimise the insertion loss, VSWR and intermodulation characteristics of the unit. The body and tuned elements are silver-plated to reduce surface ohmic losses and maintain a good VSWR figure and 50Ω load at the input and output ports. Being passive devices, the bandpass filters should have an extremely long operational life and require no maintenance.

SPECIFICATION		PARAMETER
Passband Frequency	Downlink	507.0 to 507.3MHz
Bandwidth	Downlink	0.3 MHz
Insertion Loss		2.9 dB (typical)
Power Rating		50W
Impedance		50Ω
VSWR		Better than 1.2:1
Connectors		SMA
Weight		3Kg (approximately)

4.5.5.3. Crossband Splitter/Coupler 550/800MHz (07-004815)

The purpose of Crossband Splitter/Coupler (07-004815) is to split or combine RF signals from different parts of the frequency spectrum.

It is a 3 port device comprising two filters, one a low pass, the other a high pass, connected to a common input/output. The couplers are housed in a machined aluminium casing having a centre screening wall between the filter sections and lid secured by screws at frequent intervals over its perimeter to obtain a tight seal and to ensure linearity and stability of response.

07-004815 Specification

Parameter		Low Pass Port	High Pass Port
Passband Frequencies		380 to 550MHz	800 to 960MHz
Insertion loss		<0.5dB	<0.5dB
Isolation between Bands		>50dB	>50dB
VSWR		1.3:1	
Impedance		50 ohm	
Power rating		50W	
Temperature range	operation	-20°C to +60°C	
	storage	-40°C to +70°C	
RF Connectors		SMA (female)	
Weight		<1kg	

4.5.5.4. Crossband Splitter/Coupler VHF/UHF (07-005754)

The purpose of Crossband Splitter/Coupler (07-005754) is to split or combine RF signals from different parts of the frequency spectrum.

It is a 3 port device comprising two filters, one a low pass, the other a high pass, connected to a common input/output. The couplers are housed in a machined aluminium casing having a centre screening wall between the filter sections and lid secured by screws at frequent intervals over its perimeter to obtain a tight seal and to ensure linearity and stability of response.

Parameter	Low Pass Port	High Pass Port
Passband Frequencies	70 to 175 MHz	380 to 500 MHz
Insertion loss	<0.5dB	<0.5dB
Return loss	>14dB typical	>14dB typical
Isolation between Bands	>60dB	>60dB
Impedance	50 ohm	
Power rating	50W	
Temperature range	operation	-20°C to +60°C
	storage	-40°C to +70°C
RF Connectors	SMA (female)	
Weight	<1kg	

4.5.5.5. 30dB Bi-Directional Coupler (07-022005)

The purpose of these couplers is to tap off known portions (in this case 30dB) of RF signal from transmission lines and to combine them, for example through splitter units for different purposes (alarms/monitoring etc.), whilst maintaining an accurate 50Ω load to all ports/interfaces throughout the specified frequency range. 07-022005 is a Bi-Directional device and as such will couple 30dB of signal whichever direction the signal is traveling.

07-022005 Specification

PARAMETER	SPECIFICATION
Frequency Range	100kHz – 2.7GHz
Mainline Insertion Loss	< 1.0 dB
Coupling Loss	30 dB
Coupling Loss Tolerance	+/-2.0 dB
VSWR Mainline	Better than 1.4:1
Impedance	50 Ω
Power Handling (CW)	5W
Outline (W x D x H)	44.5mm x 41mm x 27mm (ex. connectors)
Connectors	SMA (female) on all ports
Case Material	Aluminium
Finish	Iridite NCP
Operating Temperature	-20 to +55°C
Weather Protection	IP54

4.6. Downlink Output Shelf 80-301408

Downlink Output Shelf 80-301408 is part of the main Splitter/Combiner assembly. Signals are received from the various amplification stages and then combined into a single signal which is output to the radiating cable. The unit is housed in a 4U, 19" rack mount case which is mounted in Rack 2

Ports labelled A to D (Annotated A to D in section 4.6.4.1.) are the Downlink inputs from the amplification stages.

The Downlink signal leaves the Downlink Output Shelf 80-301408 for the radiating cable via the port labelled "DOWNLINK OUTPUT" (F in section 4.6.4.1.) and there is a 30dB test port labelled "DOWNLINK OUTPUT TEST PORT" (G in section 4.6.4.1.).

Downlink Output Shelf 80-301408 also incorporates bandpass filtering for the three UHF bands, the filters are placed in the RF path before the outputs to the radiating cable.

4.6.1. Downlink Output Shelf 80-301408 System Schematic

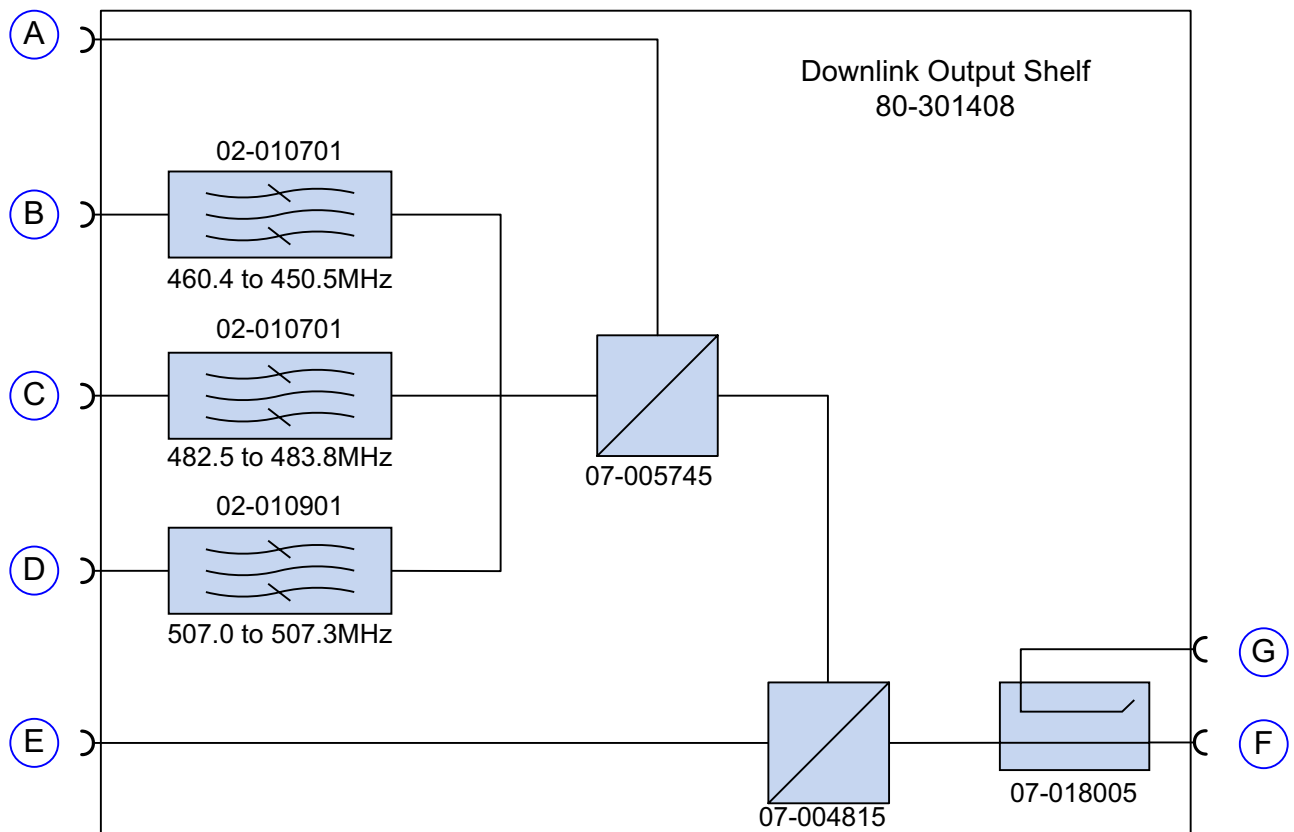

A	Port A. Downlink VHF Input from VHF Amplifier Shelf 80-301409
B	Port B. Downlink UHF Lowband Input from UHF Lowband Amplifier Shelf 80-301410
C	Port C. Downlink UHF Midband Input from UHF Midband Amplifier Shelf 80-301410
D	Port D. Downlink UHF Highband Input from UHF Highband Amplifier Shelf 80-301410
E	Port E. Downlink 800MHz Input from 800MHz Amplifier Shelf 80-301411
F	Downlink Output to Radiating Cable
G	Downlink Output Test Port (30dB Tap)

4.6.2. Downlink Output Shelf 80-301408 Outline Drawing

Drawing Number 80-301498

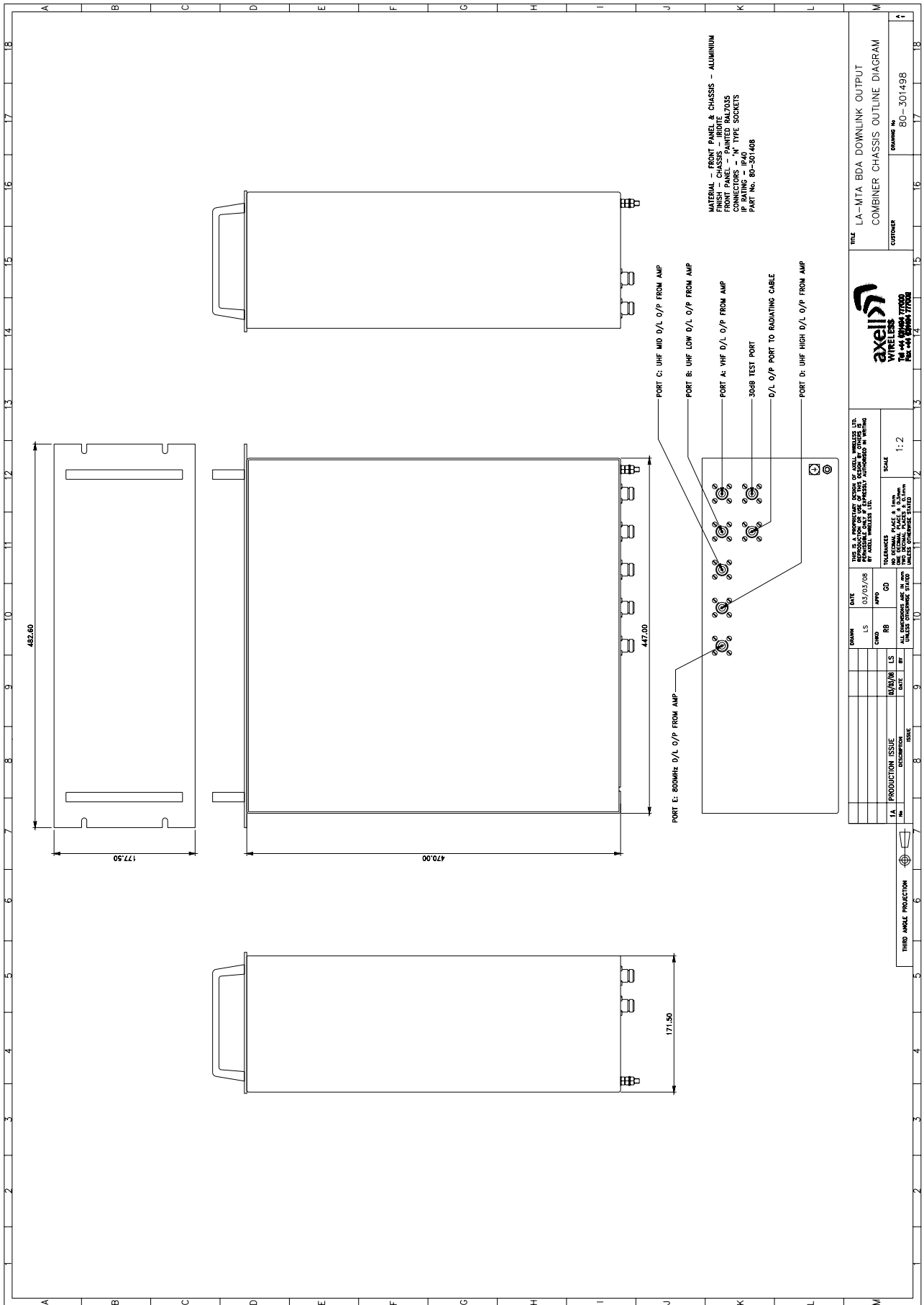

4.6.3. Downlink Output Shelf 80-301408 Specification

PARAMETER	SPECIFICATION
Insertion Loss from port indicated to Downlink Output	
VHF Band from port A	< 1.0dB at 154.0 – 161.3MHz
UHF Low Band from port B	< 3.5dB at 460.4 – 460.5MHz
UHF Mid Band from port C	< 3.5dB at 482.5 -483.8MHz
UHF High Band from port D	< 4.0dB at 507.0 – 507.3MHz
800MHz Band from port E	< 1.0dB at 856.0 – 861.0MHz
Insertion Loss from port indicated to Downlink Output Test port	
VHF Band from port A	31.0dB at 154.0 – 161.3MHz
UHF Low Band from port B	33dB at 460.4 – 460.5MHz
UHF Mid Band from port C	33dB at 482.5 – 483.8MHz
UHF High Band from port D	33dB at 507.0 – 507.3MHz
800MHz Band from port E	31dB at 856.0 – 861.0MHz

4.6.4. Downlink Output Shelf 80-301408 Illustrations

4.6.4.1. Rear View

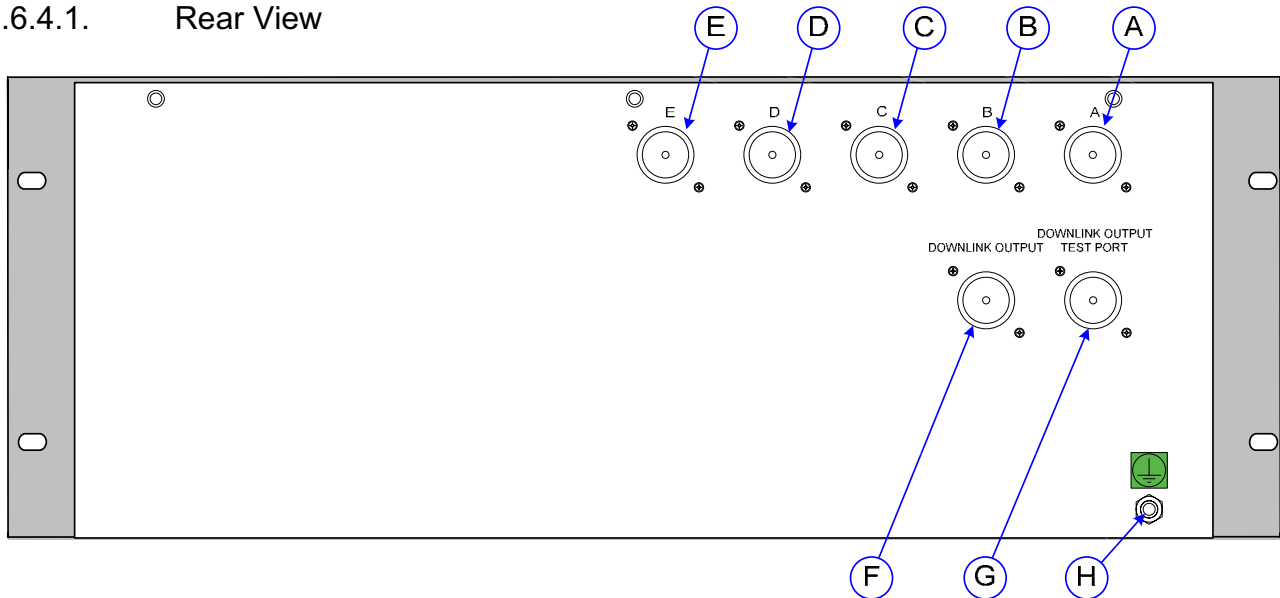

A	Port A. Downlink VHF Input from VHF Amplifier Shelf 80-301409
B	Port B. Downlink UHF Lowband Input from UHF Lowband Amplifier Shelf 80-301410
C	Port C. Downlink UHF Midband Input from UHF Midband Amplifier Shelf 80-301410
D	Port D. Downlink UHF Highband Input from UHF Highband Amplifier Shelf 80-301410
E	Port E. Downlink 800MHz Input from 800MHz Amplifier Shelf 80-301411
F	Downlink Output to Radiating Cable
G	Downlink Output Test Port (30dB Tap)
H	Earth Connection

4.6.5. Downlink Output Shelf 80-301408 Major Sub Components

Section	Component Part	Component Part Description	Qty Per Assembly
4.5.5.1.	02-010701	Bandpass Filter	2
4.5.5.2.	02-010901	Bandpass Filter	1
4.5.5.3.	07-004815	Crossband Splitter/Coupler 550/800MHz	1
4.5.5.4.	07-005754	Crossband Splitter/Coupler VHF/UHF	1
4.5.5.1.	07-018005	30dB Directional Coupler	1

These components are identical to those in Downlink Input Shelf 80-301407 in section 4.5.5 with the exception of the 30dB Directional Coupler 07-018005 below

4.6.5.1. 30dB Directional Coupler (07-018005)

The purpose of these couplers is to tap off known portions (in this case 30dB) of RF signal from transmission lines and to combine them, for example through splitter units for different purposes (alarms/monitoring etc.), whilst maintaining an accurate 50Ω load to all ports/interfaces throughout the specified frequency range. 07-018005 is a Uni-Directional device and as such will only couple 30dB of signal in one direction.

07-018005 Specification

PARAMETER		SPECIFICATION
Frequency Range		70 MHz - 1000MHz
Mainline Insertion Loss		<0.5
Coupling Loss		30 dB
VSWR Mainline		Better than 1.3:1
Impedance		50 Ω
Power Handling (CW)		100W
Outline (W x D x H)		176mm x 104mm x 24mm (ex. connectors)
Connectors		N (female) on all ports
Case Material		Aluminium
Finish		Iridite NCP
Temperature range	operation	-20°C to +60°C
	storage	-40°C to +70°C
Weather Protection		IP54

4.7. Uplink Input Shelf 80-301407

Uplink Input Shelf 80-301407 is part of the main Splitter/Combiner assembly. Signals are received from the leaky feeder and are then split into their various separate paths before being amplified by external band specific amplifiers. The unit is housed in a 4U, 19" rack mount case which is mounted in Rack 1.

Uplink signals are received at the port labelled "UPLINK INPUT" (Annotated A in the picture in section 4.7.4.1.) and there is a 30dB test port labelled "UPLINK INPUT TEST PORT" (B in section 4.7.4.1.).

Ports labelled F to J (Annotated C to G in section 4.7.4.1.) are the Uplink Outputs to the amplification stages.

Uplink Input Shelf 80-301407 also incorporates bandpass filtering for the three UHF bands, the filters are placed in the RF path before the outputs to the external amplification stages.

4.7.1. Uplink Input Shelf 80-301407 System Schematic

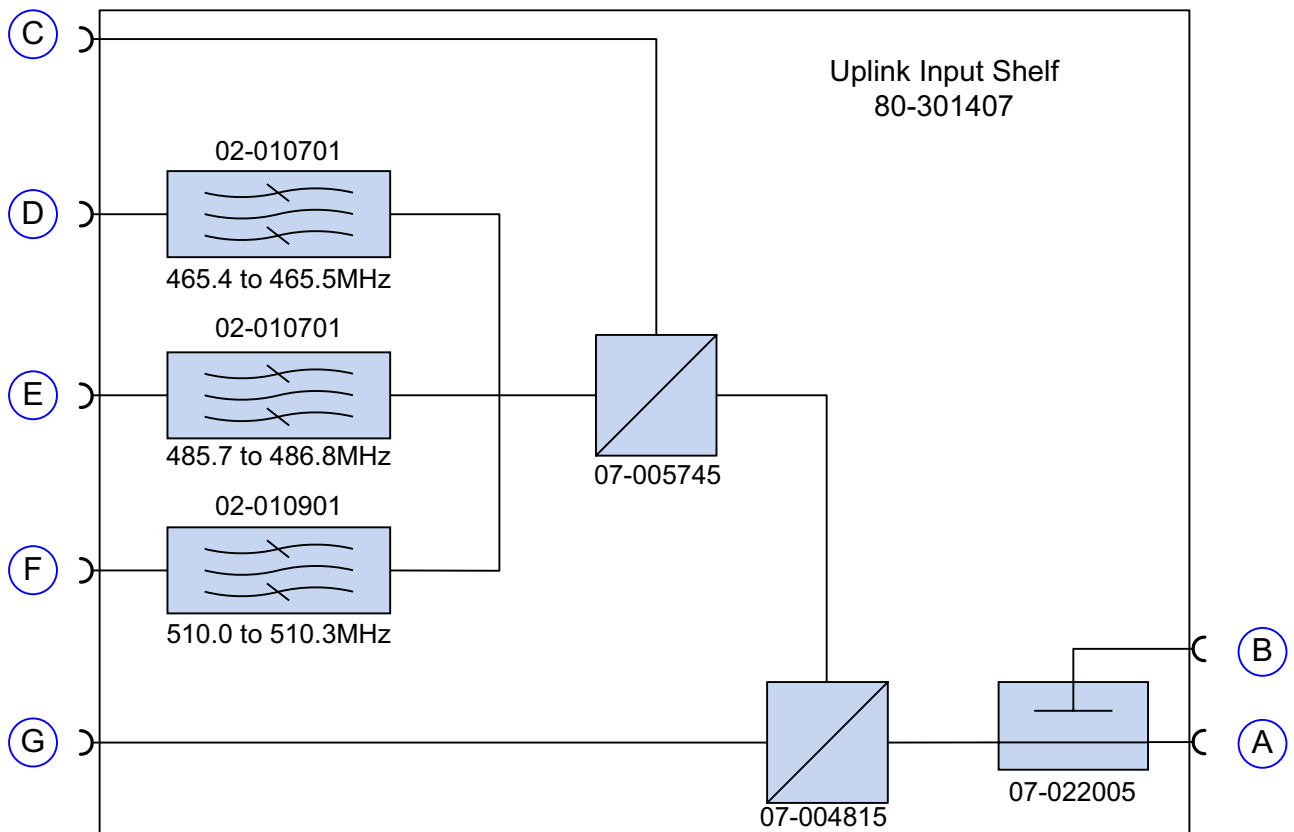

A	Uplink Input from Radiating Cable
B	Uplink Input Test Port (30dB Tap)
C	Port F. Uplink VHF Output to VHF Amplifier Shelf 80-301409
D	Port G. Uplink UHF Lowband Output to UHF Lowband Amplifier Shelf 80-301410
E	Port H. Uplink UHF Midband Output to UHF Midband Amplifier Shelf 80-301410
F	Port I. Uplink UHF Highband Output to UHF Highband Amplifier Shelf 80-301410
G	Port J. Uplink 800MHz Output to 800MHz Amplifier Shelf 80-301411

4.7.2. Uplink Input Shelf 80-301407 Outline Drawing

Drawing Number 80-301497 – see section 4.5.2.

4.7.3. Uplink Input Shelf 80-301407 Specification

PARAMETER	SPECIFICATION
Insertion Loss from from Uplink Input port to port indicated	
VHF Band to port F	< 1.0dB at 155.7 – 160.8MHz
UHF Low Band to port G	< 3.5dB at 465.4 – 465.5MHz
UHF Mid Band to port H	< 3.5dB at 485.7 -486.8MHz
UHF High Band to port I	< 4.0dB at 510.0 – 510.3MHz
800MHz Band to port J	< 1.0dB at 811.0 – 816.0MHz
Insertion Loss from port indicated to Uplink Input test port	
VHF Band	31dB at 155.7 – 160.8MHz
UHF Low Band	33dB at 465.4 – 465.5MHz
UHF Mid Band	33dB at 485.7 – 486.8MHz
UHF High Band	33dB at 510.0 – 510.3MHz
800MHz Band	31dB at 811.0 – 816.0MHz

4.7.4. Uplink Input Shelf 80-301407 Illustrations

4.7.4.1. Rear View

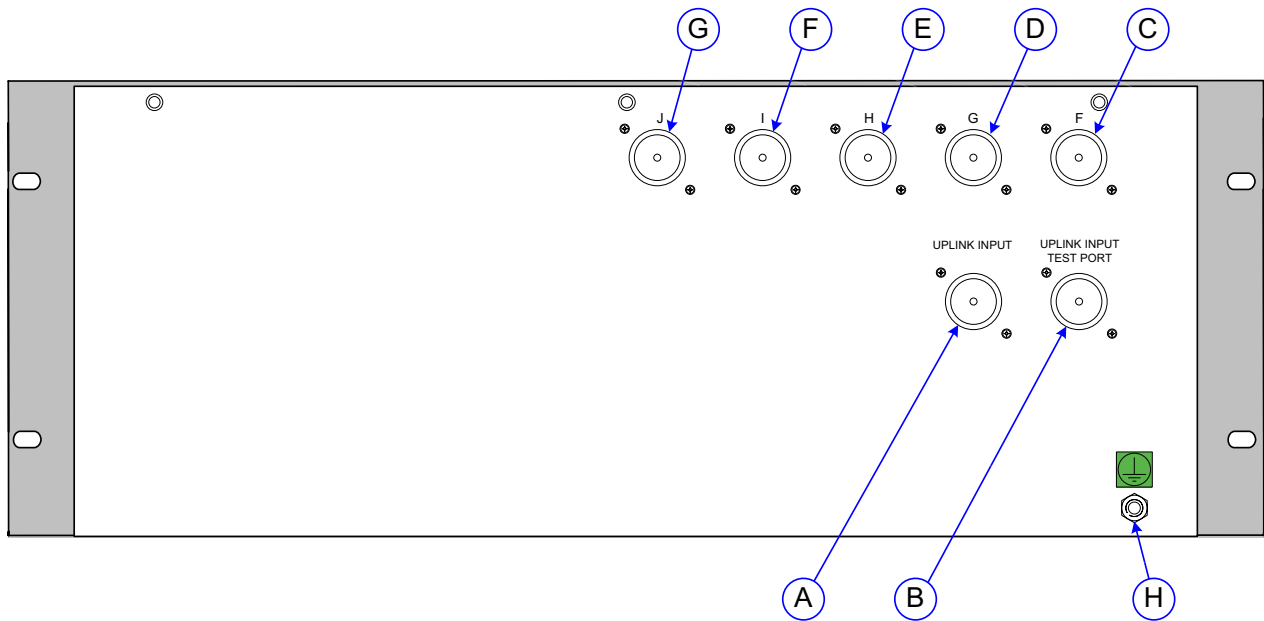

A	Uplink Input from Radiating Cable
B	Uplink Input Test Port (30dB Tap)
C	Port F. Uplink VHF Output to VHF Amplifier Shelf 80-301409
D	Port G. Uplink UHF Lowband Output to UHF Lowband Amplifier Shelf 80-301410
E	Port H. Uplink UHF Midband Output to UHF Midband Amplifier Shelf 80-301410
F	Port I. Uplink UHF Highband Output to UHF Highband Amplifier Shelf 80-301410
G	Port J. Uplink 800MHz Output to 800MHz Amplifier Shelf 80-301411
H	Earth Connection

4.7.5. Uplink Input Shelf 80-301407 Major Sub Components

section	Component Part	Component Part Description	Qty Per Assembly
4.5.5.1.	02-010701	Bandpass Filter	2
4.5.5.2.	02-010901	Bandpass Filter	1
4.5.5.3.	07-004815	Crossband Splitter/Coupler 550/800MHz	1
4.5.5.4.	07-005754	Crossband Splitter/Coupler VHF/UHF	1
4.5.5.5.	07-022005	30dB Bi-Directional Coupler	1

These components are identical to those in Downlink Input Shelf 80-301407 in section 4.5.5.

4.8. Uplink Output Shelf 80-301407

Uplink Output Shelf 80-301407 is part of the main Splitter/Combiner assembly. Signals are received from the various amplification stages and then combined into a single signal which is output to the leaky feeder. The unit is housed in a 4U, 19" rack mount case which is mounted in Rack 1.

Ports labelled 6 to 10 (Annotated A to E in section 4.8.4.1.) are the Uplink inputs from the amplification stages.

The Uplink signal leaves the Uplink Output Shelf 80-301407 for the leaky feeder via the port labelled "UPLINK OUTPUT" (F in section 4.8.4.1.) and there is a 30dB test port labelled "UPLINK OUTPUT TEST PORT" (G in section 4.8.4.1.).

4.8.1. Uplink Output Shelf 80-301407 System Schematic

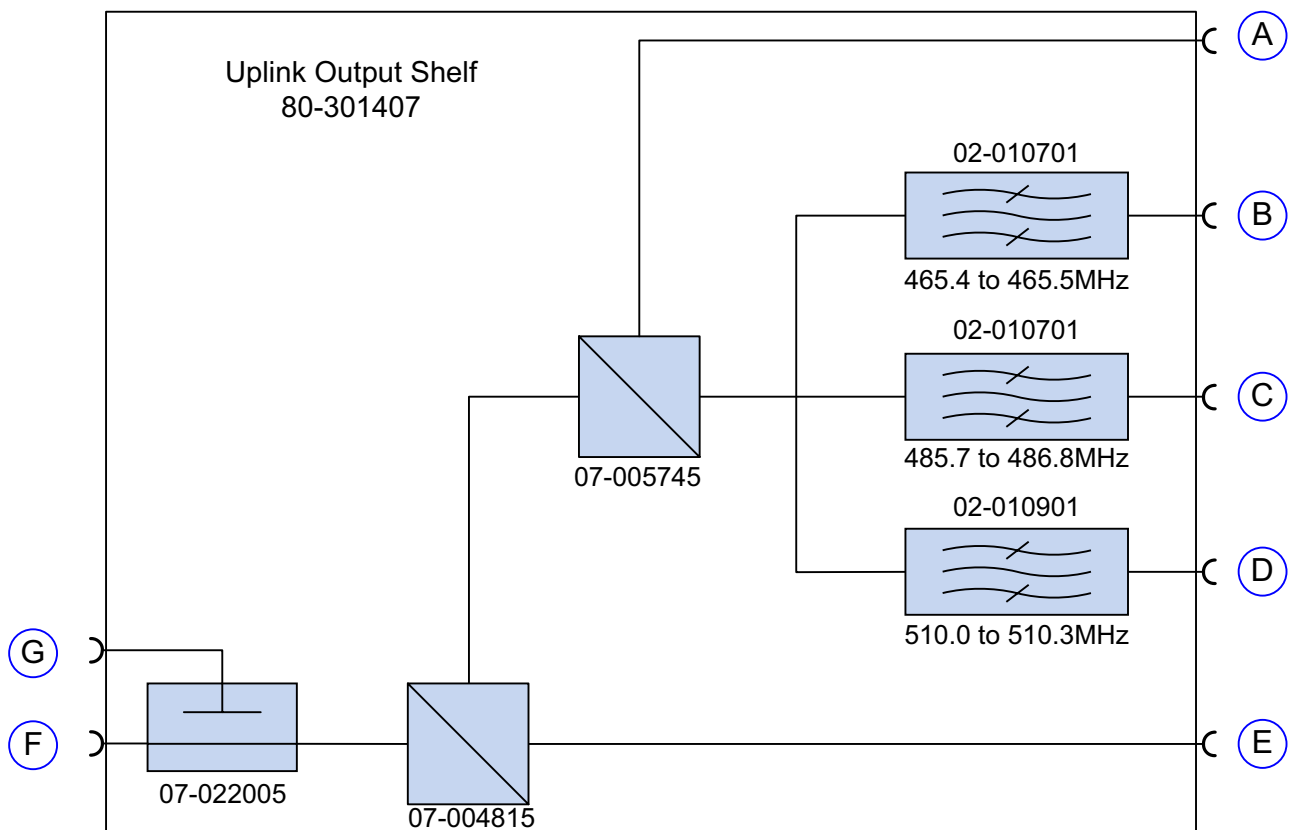

A	Port 6. Uplink VHF Input from VHF Amplifier Shelf 80-301409
B	Port 7. Uplink UHF Lowband Input from UHF Lowband Amplifier Shelf 80-301410
C	Port 8. Uplink UHF Midband Input from UHF Midband Amplifier Shelf 80-301410
D	Port 9. Uplink UHF Highband Input from UHF Highband Amplifier Shelf 80-301410
E	Port 10. Uplink 800MHz Input from 800MHz Amplifier Shelf 80-301411
F	Uplink Output to Radiating Cable
G	Uplink Output Test Port (30dB Tap)

4.8.2. Uplink Output Shelf 80-301407 Outline Drawing

Drawing Number 80-301497 – see section 4.5.2.

4.8.3. Uplink Output Shelf 80-301407 Specification

PARAMETER	SPECIFICATION
Insertion Loss from port indicated to Uplink Output	
VHF Band from port 6	< 1.0dB at 155.7 – 160.8MHz
UHF Low Band from port 7	< 3.5dB at 465.4 – 465.5MHz
UHF Mid Band from port 8	< 3.5dB at 485.7 -486.8MHz
UHF High Band from port 9	< 4.0dB at 510.0 – 510.3MHz
800MHz Band from port 10	< 1.0dB at 811.0 – 816.0MHz
Insertion Loss from port indicated to Uplink Output Test port	
VHF Band from port 6	31dB at 155.7 – 160.8MHz
UHF Low Band from port 7	33dB at 465.4 – 465.5MHz
UHF Mid Band from port 8	33dB at 485.7 – 486.8MHz
UHF High Band from port 9	33dB at 510.0 – 510.3MHz
800MHz Band from port 10	31dB at 811.0 – 816.0MHz

4.8.4. Uplink Output Shelf 80-301407 Illustrations

4.8.4.1. Rear View

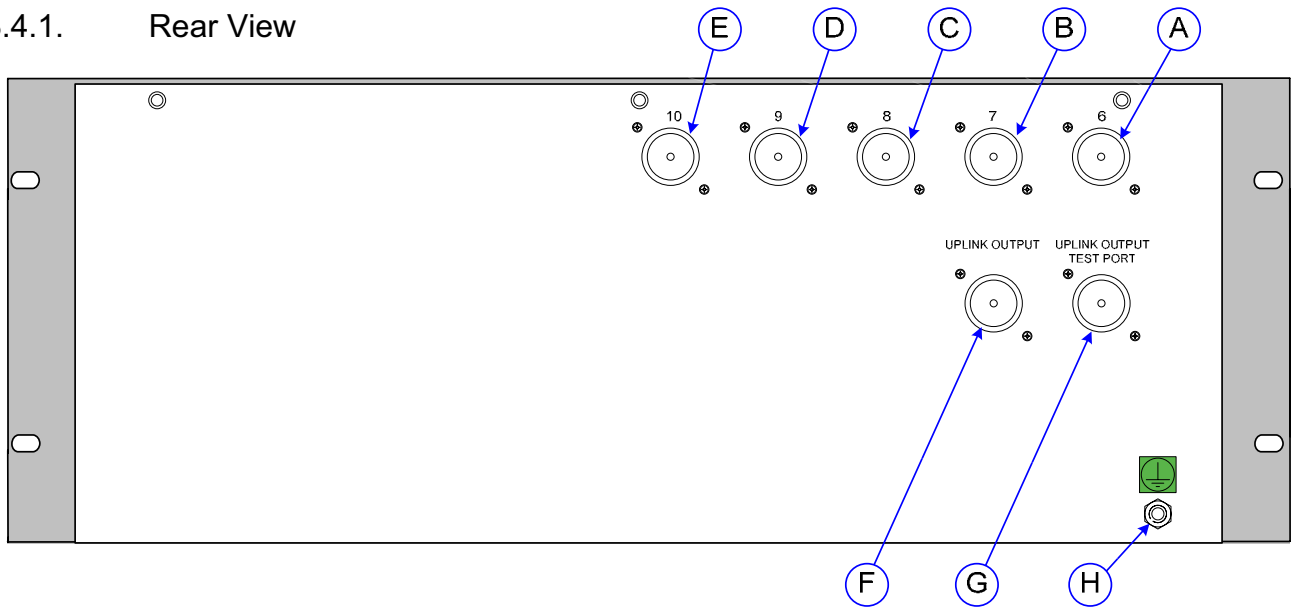

A	Port 6. Uplink VHF Input from VHF Amplifier Shelf 80-301409
B	Port 7. Uplink UHF Lowband Input from UHF Lowband Amplifier Shelf 80-301410
C	Port 8. Uplink UHF Midband Input from UHF Midband Amplifier Shelf 80-301410
D	Port 9. Uplink UHF Highband Input from UHF Highband Amplifier Shelf 80-301410
E	Port 10. Uplink 800MHz Input from 800MHz Amplifier Shelf 80-301411
F	Uplink Output to Radiating Cable
G	Uplink Output Test Port (30dB Tap)
H	Earth Connection

4.8.5. Uplink Output Shelf 80-301407 Major Sub Components

section	Component Part	Component Part Description	Qty Per Assembly
4.5.5.1.	02-010701	Bandpass Filter	2
4.5.5.2.	02-010901	Bandpass Filter	1
4.5.5.3.	07-004815	Crossband Splitter/Coupler 550/800MHz	1
4.5.5.4.	07-005754	Crossband Splitter/Coupler VHF/UHF	1
4.5.5.5.	07-022005	30dB Bi-Directional Coupler	1

These components are identical to those in Downlink Input Shelf 80-301407 in section 4.5.5.

4.9. VHF Amplifier Shelf 80-301409

VHF Amplifier Shelf 80-301409 provides the amplification stages for the VHF paths, The unit is housed in a 4U, 19" rack mount shelf which is mounted in Rack 1

The Downlink VHF signal is received at the port labelled "DOWNLINK I/P" (Annotated A in the picture in section 4.9.4.2.). The Downlink VHF path passes through a bandpass filter to remove out of band noise and then a switched attenuator providing 0 to 30 dB of RF signal attenuation.

After leaving the attenuator the VHF Downlink signal passes through a 5W amplification stage, this amplification stage is straddled by an Automatic Gain Control assembly providing limiting to the output signals in the case of high input signals.

After leaving the Amplification/AGC stage the VHF Downlink signal passes through a second bandpass filter and exits the Shelf via the port labelled "DOWNLINK O/P" (B in section 4.9.4.2.).

The Uplink VHF Signal is received at the port labelled "UPLINK I/P" (C in section 4.9.4.2.). The VHF Uplink path passes through a bandpass filter to remove out of band noise and then a switched attenuator providing 0 to 30 dB of RF signal attenuation.

After leaving the attenuator the VHF Uplink signal passes through a 5W amplification stage, this amplification stage is straddled by an Automatic Gain Control assembly providing limiting to the output signals in the case of high input signals.

After leaving the Amplification/AGC stage the VHF Uplink signal passes through a second bandpass filter and exits the Shelf via the port labelled "UPLINK O/P" (D in section 4.9.4.2.).

VHF Amplifier Shelf 80-301409 is provided with a 24V DC input to power the amplifier modules within and those amplifier modules are configured to provide alarm status reports.

4.9.1. VHF Amplifier Shelf 80-301409 System Diagram

Drawing Number 80-301489

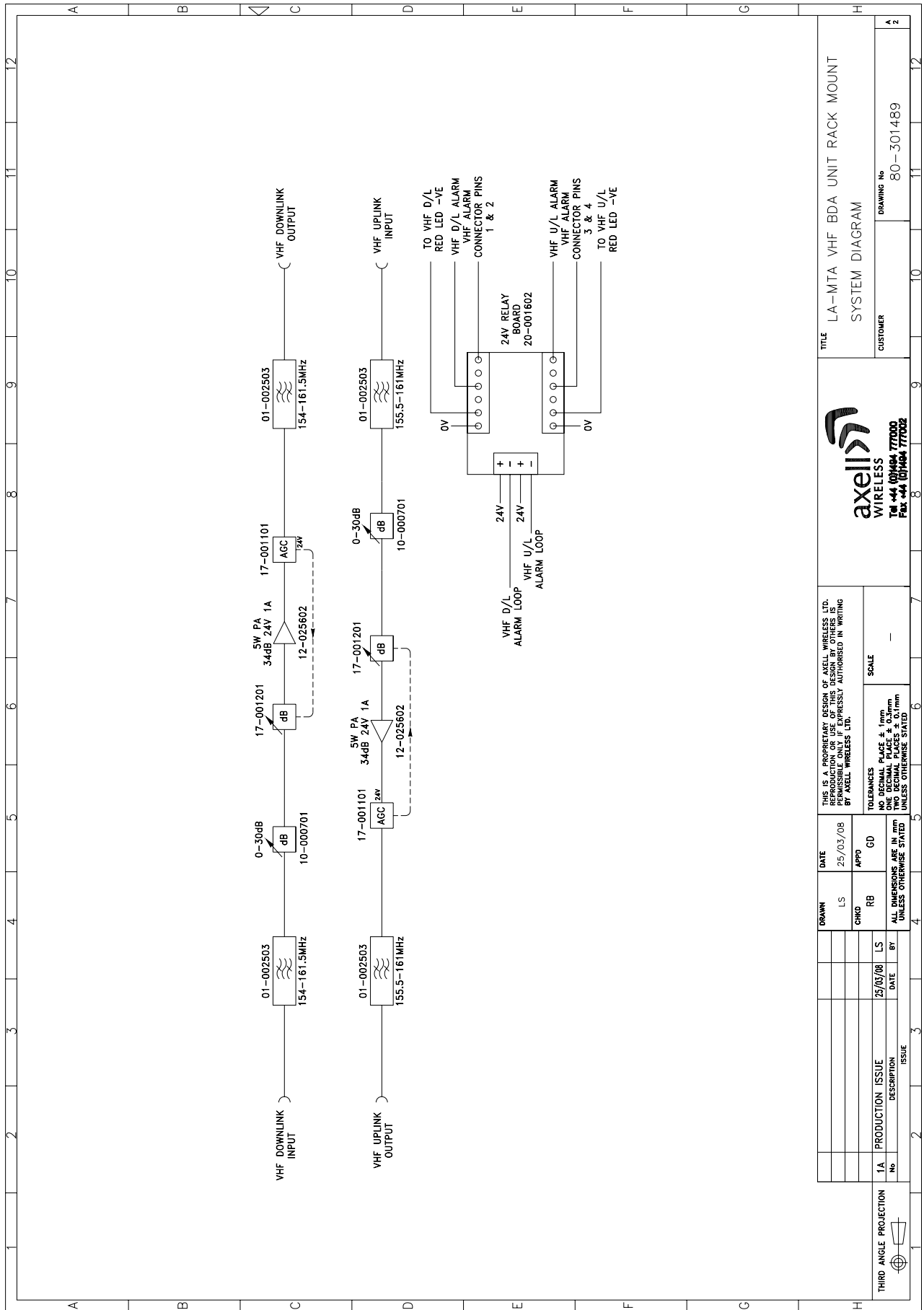

<p>axell WIRELESS Tel: +44 (0)1464 77000 Fax: +44 (0)1464 77002</p>		<p>TITLE: LA-MTA VHF BDA UNIT RACK MOUNT SYSTEM DIAGRAM</p> <p>CUSTOMER: 80-301489 DRAWING No: 80-301489</p>
<p>THIS IS A PROPRIETARY DESIGN OF AXELL WIRELESS LTD. NO PARTS OF THIS DESIGN ARE TO BE REPRODUCED OR PERMITTED IN ANY MANNER WITHOUT THE EXPRESSLY AUTHORIZED WRITING BY AXELL WIRELESS LTD.</p>		<p>SCALE: —</p>
<p>DATE: 25/03/08</p>	<p>APPROVED: LS RB GD</p>	<p>NO. DECIMAL PLACES ± 1mm TWO DECIMAL PLACES ± 0.1mm UNLESS OTHERWISE STATED</p>
<p>PRODUCTION ISSUE</p>	<p>DATE: 25/05/08</p>	<p>ISSUE</p>

4.9.2. VHF Amplifier Shelf 80-301409 Outline Drawing

Drawing Number 80-301499

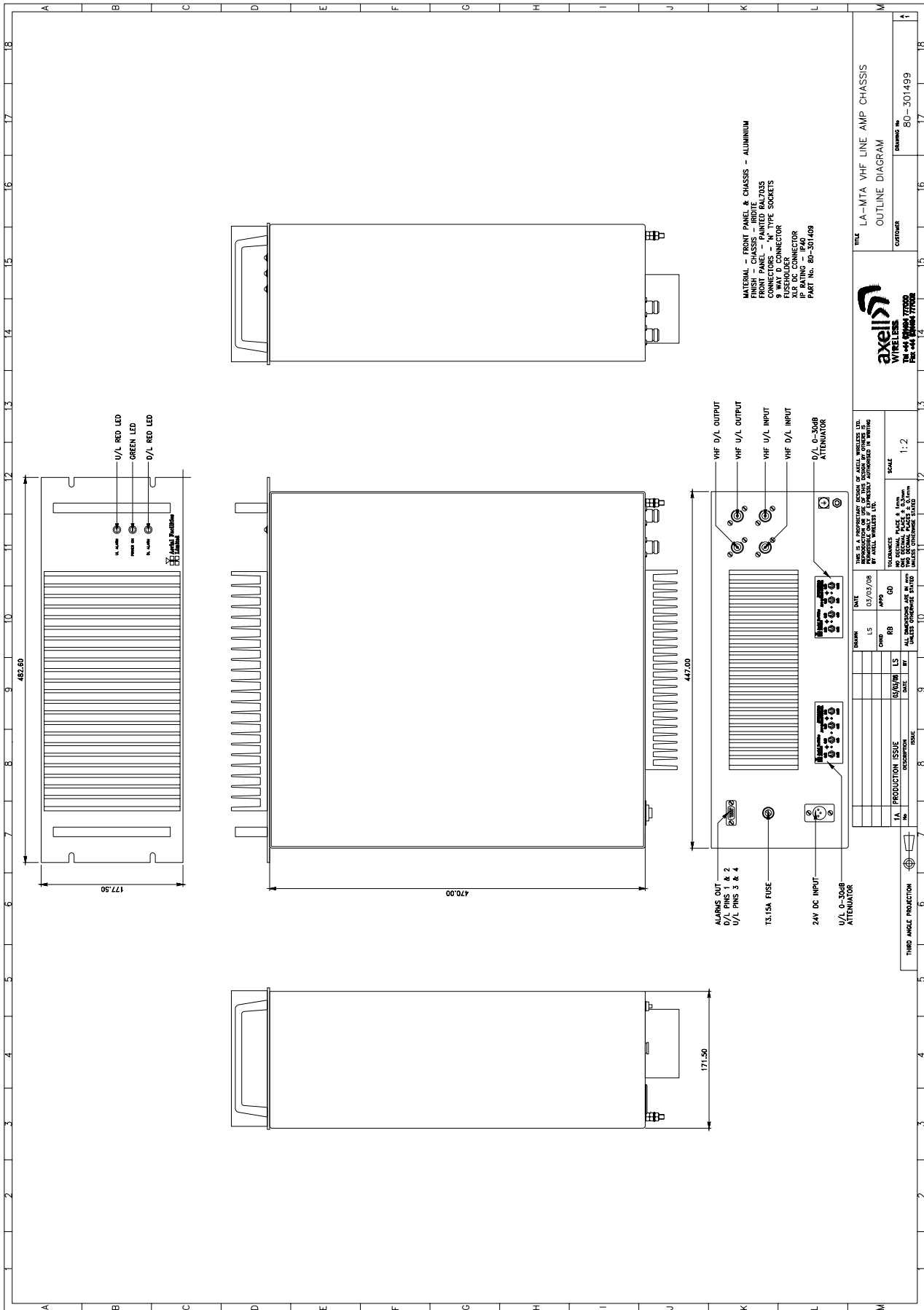

4.9.3. VHF Amplifier Shelf 80-301409 Specification

Parameter	Specification
Downlink	
Downlink Passband	154.0 to 161.5MHz
Maximun gain	30dB
Gain Adjustment	0 to 30dB in 2dB steps
1dB Compression Point (P1dB)	+34.0dBm
ALC setting	1dB below P1dB
3 rd Order Intercept point	+45.0dBm
Uplink	
Uplink Passband	155.5 – 161.0MHz
Maximun gain	30dB
Gain Adjustment	0 to 30dB in 2dB steps
1dB Compression Point (P1dB)	+34.0dBm
ALC setting	+27dBm
3 rd Order Intercept point	+45.0dBm
Noise Figure	< 10dB
Mechanical Specification	
Mechanical	4U, 19" Rack Mount
RF Connectors	N-Type Female
Alarm Interfaces	Local Alarms to SCADA Dry Contact with LED Indication per path
Power Supply	24V DC

4.9.4. VHF Amplifier Shelf 80-301409 Illustrations

4.9.4.1. Front View

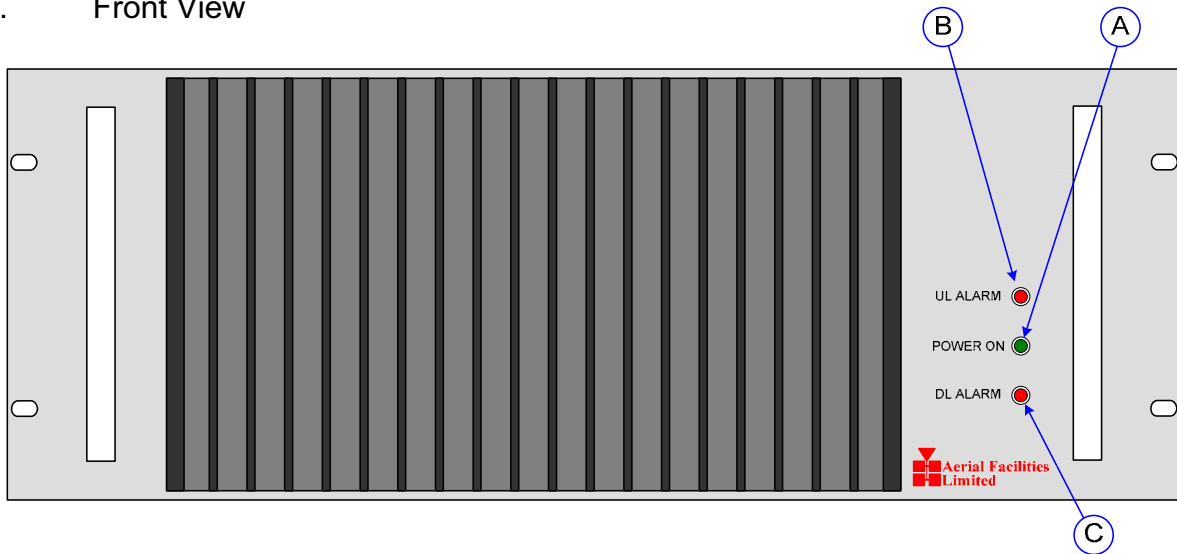

A	Green LED "Power On"
B	Red LED "Alarm" VHF Uplink path
C	Red LED "Alarm" VHF Downlink path

4.9.4.2. Rear View

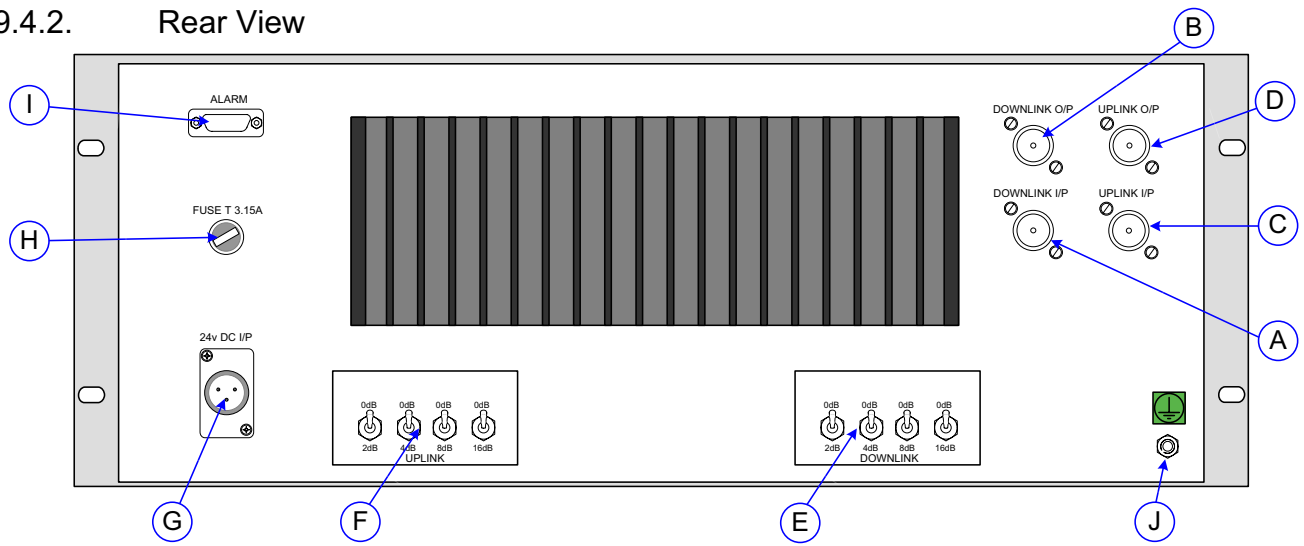

A	VHF Downlink Input from Downlink Input Shelf 80-301407 Port 1
B	VHF Downlink Output to Downlink Output Shelf 80-301408 Port A
C	VHF Uplink Input from Uplink Input Shelf 80-301407 Port F
D	VHF Uplink Output to Uplink Output Shelf 80-301407 Port 6
E	VHF Downlink Switched Attenuator 0 to 30 dB
F	VHF Uplink Switched Attenuator 0 to 30 dB
G	24V DC Input
H	3.15A Fuse for 24V DC Input
I	Alarm Output
J	Earth Connection

4.9.5. VHF Amplifier Shelf 80-301409 Major Sub Components

Section	Component Part	Component Part Description	Qty Per Assembly
4.9.5.1.	01-002503	Bandpass Filter	4
4.9.5.2.	10-000701	Switched Attenuator 0.25Watt, 0 - 30dB	2
4.9.5.3.	12-025602	VHF Power Amplifier 5W	2
4.9.5.4.	17-001101	AGC Detector Assembly	2
	17-001201	AGC Attenuator Assembly	2
4.9.5.5.	20-001602	24V Dual Relay Assembly	1
4.9.5.6.	94-100004	Dual Diode Assembly	1

4.9.5.1. Bandpass Filter (01-002503)

The bandpass filters are multi-section designs with a bandwidth dependent upon the passband frequencies, (both tuned to customer requirements). The response shape is basically Chebyshev with a passband design ripple of 0.1dB. The filters are of helical design, and are carefully aligned during manufacture in order to optimise the insertion loss, VSWR and intermodulation characteristics of the unit. The tuned elements are silver-plated to reduce surface ohmic losses and maintain a good VSWR figure and 50Ω load at the input and output ports.

Being passive devices, the bandpass filters have an extremely long operational life and require no maintenance. Should a filter be suspect, it is usually most time efficient to replace the module rather than attempt repair or re-tuning. No adjustments should be attempted without full network sweep analysis facilities to monitor both insertion loss and VSWR simultaneously.

01-002503 Specification

SPECIFICATION		PARAMETER
Bandpass Frequency	Downlink	154.0 MHz to 161.5 MHz
	Uplink	155.5 MHz to 161.0 MHz
Bandwidth	Downlink	7.5MHz
	Uplink	5.5MHz
No. of sections		6
Insertion loss		1.2dB
VSWR		Better than 1.2:1
Connectors		SMA
Power handling		100W maximum
Temperature range	operational	-20°C to +60°C
	store	-40°C to +70°C
Weight		3 kg
Size		384 x 82.5 x 56.4mm

4.9.5.2. Switched Attenuator 0.25Watt, 0 - 30dB (10-000701)

10-000701 provides attenuation from 0 to 30dB in 2 dB steps. The attenuation is simply set using the four miniature toggle switches on the top of each unit. Each switch is clearly marked with the attenuation it provides, and the total attenuation in line is the sum of the values switched in. They are designed to maintain an accurate 50Ω impedance over their operating frequency at both input and output.

10-000701 Specification

PARAMETER		SPECIFICATION
Attenuation Values		0-30dB
Attenuation Steps		2, 4, 8 and 16dB
Power Handling		0.25 Watt
Attenuation Accuracy		± 1.0 dB
Frequency Range		DC to 1GHz
Impedance		50Ω
Connectors		SMA
VSWR		1.3:1
Weight		0.2kg
Temperature range	operation	-20°C to +60°C
	storage	-40°C to +70°C

4.9.5.3. VHF Power Amplifier 5W (12-025602)

Power amplifier 12-025602 is a multi-stage, solid state power amplifier. Class A circuitry is employed throughout the device to ensure excellent linearity over a wide dynamic frequency range. All the semiconductor devices are very conservatively rated to ensure low device junction temperatures and a long, trouble free working lifetime. There is a Current Fault Alarm Function, which indicates failure of each RF transistor with an open collector of a NPN transistor. A relay is fitted to indicate the failure by voltage free change over the relay contacts.

The power amplifier should require no maintenance over its operating life. Under no circumstances should the cover be removed or the side adjustments disturbed unless it is certain that the amplifier has failed; since it is critically aligned during manufacture and any re-alignment will require extensive test equipment.

The unit housing is an aluminium case (Iridite NCP finish) with SMA connectors for the RF input/output and a D-Type connector for the power supply and the Current Fault Alarm Function.

12-025602 Specification

PARAMETER		SPECIFICATION
Frequency range		108 to 174 MHz (as required)
Maximum RF output		> 5Watts
Gain		≥ 34 dB
1dB compression point		≥ +37 dBm
3rd order intercept point		≥ +48 dBm
In / RL		16 dB
Out / RL		15 dB
Noise Figure		≤ 9.5 dB Max
Connectors		SMA female
Supply		24 +/- 0.5 Vdc @ 1040 mA Max
Temperature range	operational	-10°C to +60°C
	storage	-20°C to +70°C

7-Way Connector Pin-out details	
Connector Pin	Signal
A1 (large pin)	+24V DC
A2 (large pin)	GND
1	Alarm relay common
2	TTL alarm/0V good
3	Alarm relay contact (bad)
4	Alarm relay contact (good)
5	O/C good/0V bad (TTL)

7-Way Connector Graphical Representation

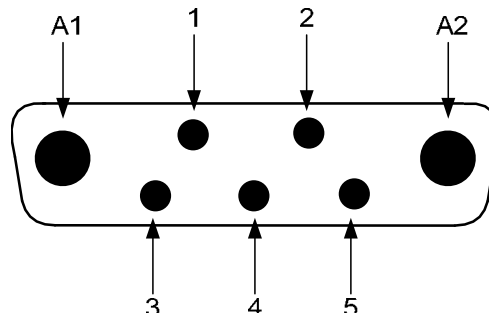

4.9.5.4. Automatic Gain Control

17-001101 AGC Detector Assembly
17-001201 AGC Attenuator Assembly

VHF Amplifier Shelf 80-301409 is fitted with two Automatic Gain Control (AGC) systems, one for the Downlink and one for the Uplink

The Automatic Gain Control system consists of two units, a detector/amplifier and an attenuator. The detector/amplifier unit is inserted in the RF path on the output of the power amplifier, and the attenuator is situated in the RF path before the amplification stage(s)

The attenuator comprises a 50Ω P.I.N diode, voltage-variable attenuator with a range of 3 to 30dB. The attenuation is controlled by a DC voltage which is derived from the associated detector controller board.

Normally the attenuator is at minimum attenuation. The detector/amplifier unit monitors the RF level being delivered by the power amplifier, and when a certain threshold is reached it begins to increase the value of the attenuator to limit the RF output to the (factory set) threshold. Therefore overloading of the power amplifier is avoided.

The factory set threshold is 1dB below the Enhancer 1dB compression point. Some adjustment of this AGC threshold level is possible, a 10dB range is mostly achieved. It is not recommended under any circumstances to adjust the AGC threshold to a level greater than the 1dB compression point as system degradation will occur.

The detector comprises of a 50Ω transmission line with a resistive tap which samples a small portion of the mainline power. The sampled signal is amplified and fed to a conventional half wave diode rectifier, the output of which is a DC voltage proportional to the RF input signal.

This DC voltage is passed via an inverting DC amplifier with integrating characteristics, to the output, which drives the attenuation control line of the corresponding AGC attenuator. This unit is fitted at some earlier point in the RF circuit.

For small signals, below AGC onset, the output control line will be close to 12V and the AGC attenuator will have minimum attenuation. As the signal level increases the control line voltage will fall, increasing the attenuator value and keeping the system output level at a constant value.

4.9.5.5. 24V Relay Dual Assembly (20-001602)

The General Purpose 24V Dual Relay Board (20-001602) allows the inversion of signals and the isolation of circuits. It is equipped with two dual pole change-over relays RL1 and RL2, with completely isolated wiring, accessed via screw terminals. Both relays are provided with polarity protection diodes and diodes for suppressing the transients caused by "flywheel effect" which can destroy switching transistors or induce spikes on neighbouring circuits. Its common use is to amalgamate all the alarm signals into one, volts-free relay contact pair for the main alarm system.

20-001602 Specification

PARAMETER		SPECIFICATION
Operating voltage		8 to 30V (floating earth)
Alarm Threshold		Vcc - 1.20 volt +15%
Alarm output relay contacts:		
Max. switch current		1.0Amp
Max. switch volts		120Vdc/60VA
Max. switch power		24W/60VA
Min. switch load		10.0 μ A/10.0mV
Relay isolation		1.5kV
Mechanical life		>2x10 ⁷ operations
Relay approval		BT type 56
Connector details		Screw terminals
Temperature range	operational	-10°C to +60°C
	storage	-20°C to +70°C

4.9.5.6. Dual Diode Assembly (94-100004)

The purpose of these dual diode assemblies is to allow two DC voltage sources to be combined, so that the main DC rail within the equipment can be sourced from either a mains driven PSU, or externally through an XLR connector or from dual mains driven PSUs . They are very heavy-duty diodes and they prevent any reverse current from flowing back to their source or the alternative supply rail. Combining diodes such as these will also be used if the equipment is to be powered from external back-up batteries.

4.10. UHF Lowband Amplifier Shelf 80-301410

UHF Lowband Amplifier Shelf 80-301410 provides the amplification stages for the UHF Lowband paths, The unit is housed in a 4U, 19" rack mount shelf which is mounted in Rack 1

The Downlink UHF Lowband signal is received at the port labelled "UHF DOWNLINK I/P" (Annotated A in section 4.10.4.2.). The signal passes through a switched attenuator providing 0 to 30 dB of RF signal attenuation and then into the amplification stage. The Downlink UHF Lowband amplification stage is provided by two amplifier modules, the first is a 15dB gain Low Power Amplifier and the second is a 20W, 23dB gain power amplifier. Both amplification stages are straddled by an Automatic Gain Control assembly providing limiting to the output signals in the case of high input signals.

The input to the AGC detector is provided by the output of a 30dB tap. After leaving the Amplification/AGC stage the Downlink UHF Lowband signal exits the Shelf via the port labelled "UHF DOWNLINK O/P" (B in section 4.10.4.2.).

The Uplink UHF Lowband signal is received at the port labelled "UHF UPLINK I/P" (Annotated C in section 4.10.4.2.). The signal passes into a Low Noise Amplifier providing 15dB of gain and then into a switched attenuator providing 0 to 30 dB of RF signal attenuation. After the attenuator the Uplink UHF Lowband signal passes into a second stage of amplification provided by a 5W, 30dB gain Power Amplifier, this amplification stage is straddled by an Automatic Gain Control assembly providing limiting to the output signals in the case of high input signals.

The Uplink UHF Lowband signal exits the Shelf via the port labelled "UHF UPLINK O/P" (D in section 4.10.4.2.).

UHF Lowband Amplifier Shelf 80-301410 is provided with a 24V DC input to power the amplifier modules within and those amplifier modules are configured to provide alarm status reports.

4.10.1. UHF Lowband Amplifier Shelf 80-301410 System Diagram

Drawing Number 80-301490

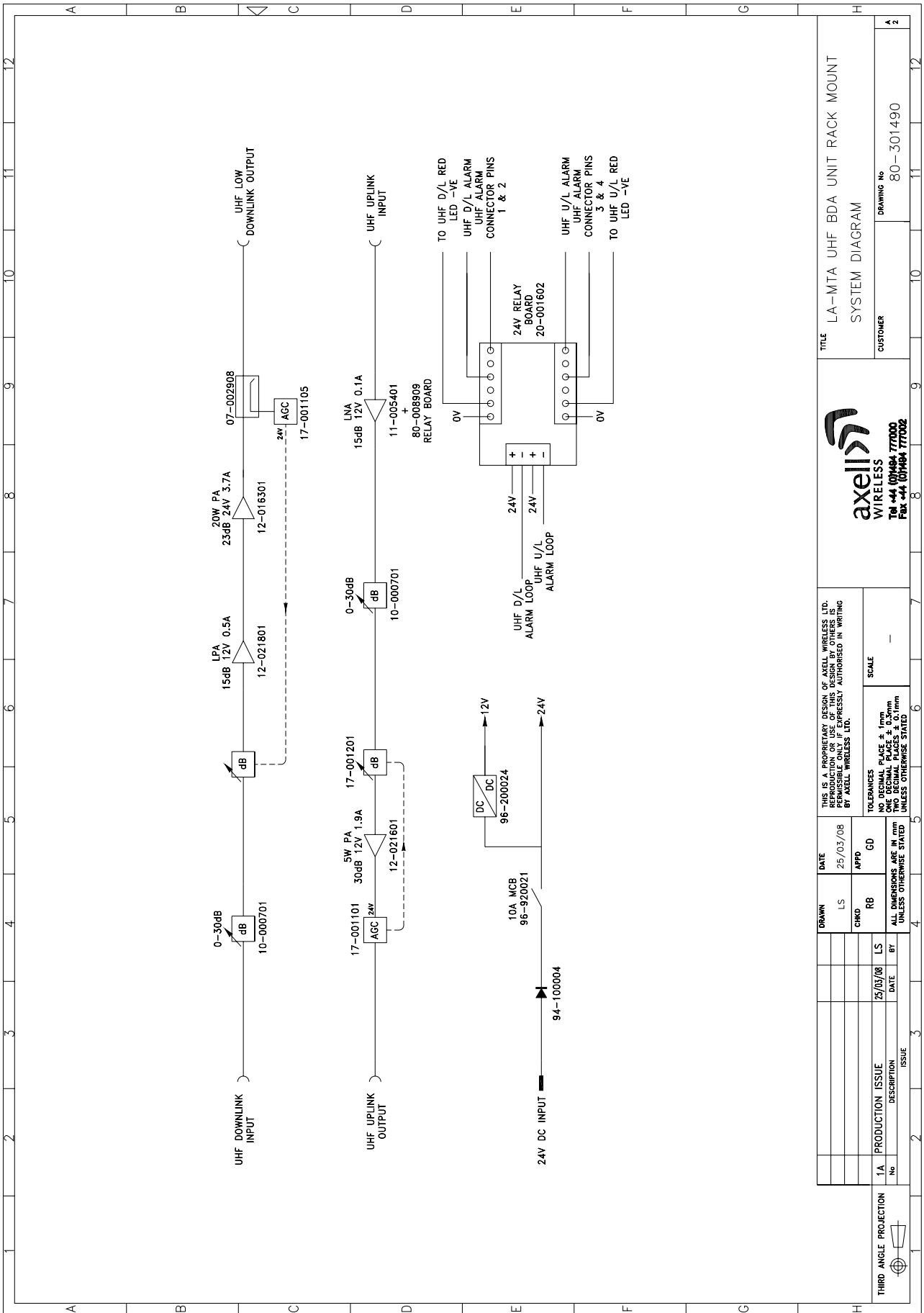

<p>Tel: +44 (0)1484 770000 Fax: +44 (0)1484 770002</p>		<p>TITLE: LA-MTA UHF BDA UNIT RACK MOUNT SYSTEM DIAGRAM</p>	
<p>THIS IS A PROPRIETARY DESIGN OF AXELL WIRELESS LTD. NO PARTS OF THIS DESIGN ARE TO BE REPRODUCED OR TRANSMITTED IN ANY FORM OR BY ANY MEANS, ELECTRONIC OR MECHANICAL, INCLUDING PHOTOCOPYING, RECORDING, OR BY ANY INFORMATION STORAGE AND RETRIEVAL SYSTEM, WITHOUT THE EXPRESS WRITTEN PERMISSION OF AXELL WIRELESS LTD.</p>		<p>CUSTOMER: 80-301490</p>	
<p>1A No</p>	<p>PRODUCTION ISSUE</p>	<p>DATE: 25/03/08</p>	<p>SCALE: -</p>
<p>DESCRIPTION</p>	<p>ISSUE</p>	<p>APPD: RB</p>	<p>GD</p>
<p>DATE</p>	<p>DATE</p>	<p>ALL DIMENSIONS ARE IN mm UNLESS OTHERWISE STATED</p>	<p>NO DECIMAL PLACE # 1mm UNLESS OTHERWISE STATED</p>
<p>DATE</p>	<p>DATE</p>	<p>LS</p>	<p>LS</p>

4.10.2. UHF Lowband Amplifier Shelf 80-301410 Outline Drawing

Drawing Number 80-3014100

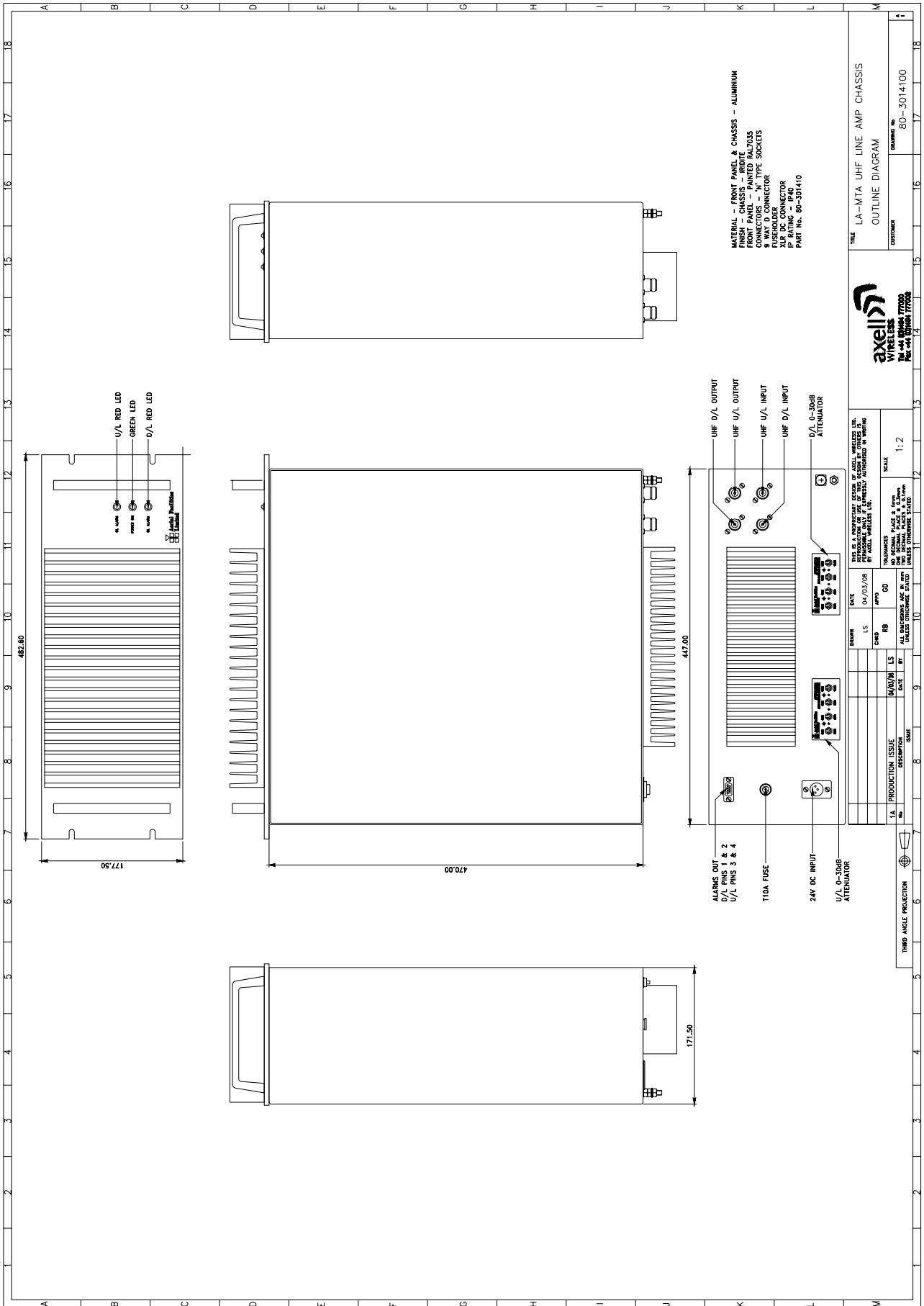

4.10.3. UHF Lowband Amplifier Shelf 80-301410 Specification

Parameter	Specification
Downlink	
Downlink Passband	460.4 to 460.5MHz
Maximun gain	30dB
Gain Adjustment	0 to 30dB in 2dB steps
1dB Compression Point (P1dB)	+42.5dBm
ALC setting	1dB below P1dB
3 rd Order Intercept point	+53.5dBm
Uplink	
Uplink Passband	465.4 – 465.5MHz
Maximun gain	30dB
Gain Adjustment	0 to 30dB in 2dB steps
1dB Compression Point (P1dB)	+36.5dBm
ALC setting	+27dBm
3 rd Order Intercept point	> +48.0dBm
Noise Figure	< 3.0dB
Mechanical Specification	
Mechanical	4U 19" Rack Mount
RF Connectors	N-Type Female
Alarm Interfaces	Local Alarms to SCADA Dry Contact with LED Indication per path
Power Supply	24V DC

4.10.4. UHF Lowband Amplifier Shelf 80-301410 Illustrations

4.10.4.1. Front View

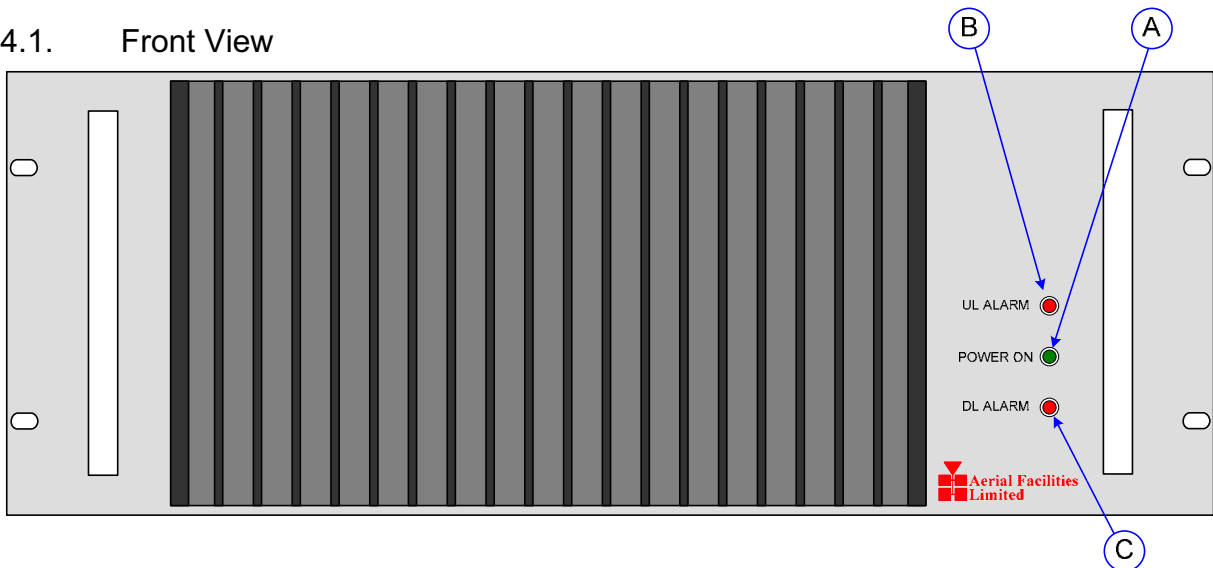

A	Green LED "Power On"
B	Red LED "Alarm" UHF Lowband Uplink path
C	Red LED "Alarm" UHF Lowband Downlink path

4.10.4.2. Rear View

N.B. UPLINK 465.4 - 465.5 MHz
 DOWNLINK 460.4 - 460.5 MHz

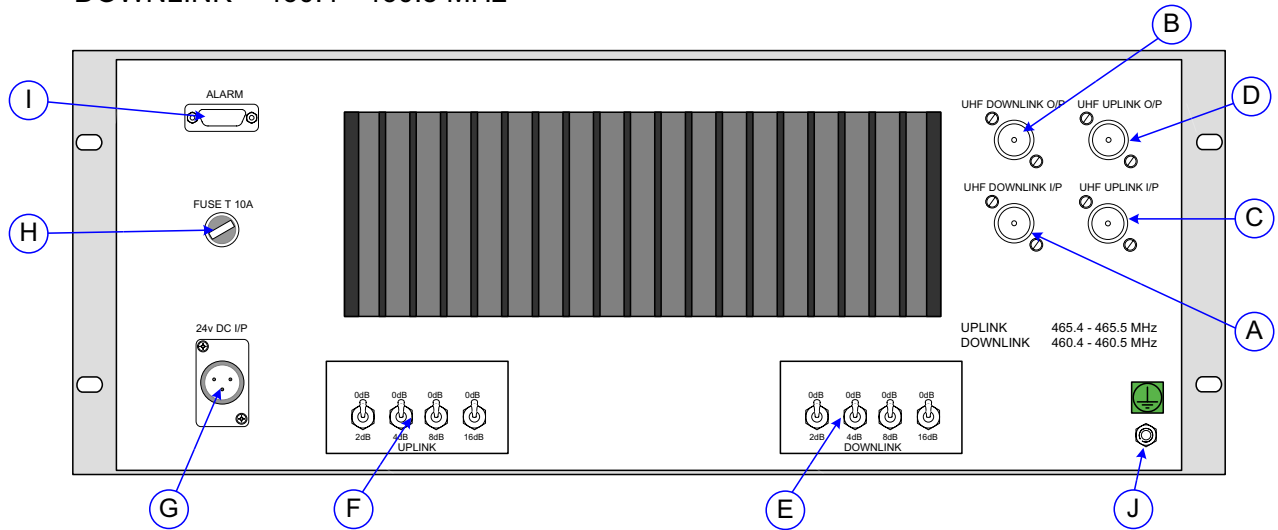

A	UHF Lowband Downlink Input from Downlink Input Shelf 80-301407 Port 2
B	UHF Lowband Downlink Output to Downlink Output Shelf 80-301408 Port B
C	UHF Lowband Uplink Input from Uplink Input Shelf 80-301407 Port G
D	UHF Lowband Uplink Output to Uplink Output Shelf 80-301407 Port 7
E	UHF Lowband Downlink Switched Attenuator 0 to 30 dB
F	UHF Lowband Uplink Switched Attenuator 0 to 30 dB
G	24V DC Input
H	10A Fuse for 24V DC Input
I	Alarm Output
J	Earth Connection

4.10.5. UHF Lowband Amplifier Shelf 80-301410 Major Sub Components

Section	Component Part	Component Part Description	Qty Per Assembly
4.10.5.1.	07-002908	30dB Directional Coupler	1
4.10.5.2.	10-000701	Switched Attenuator 0.25Watt, 0 - 30dB	2
4.10.5.3.	11-005401	Low Noise Amplifier	1
4.10.5.4.	12-016301	20W Power Amplifier	1
4.10.5.5.	12-021601	TETRA Power Amplifier 5W	1
4.10.5.6.	12-021801	TETRA Power Amplifier 1W	1
4.10.5.7.	17-001101	AGC Detector Assembly	1
	17-001105	AGC Detector Assembly (Logarithmic)	1
	17-001201	AGC Attenuator Assembly	2
4.10.5.8.	20-001602	24V Dual Relay Assembly	1
4.10.5.9.	80-008909	12V Relay Assembly	1
4.10.5.10.	94-100004	Dual Diode Assembly	1
4.10.5.11.	96-200024	DC/DC Converter	1

4.10.5.1. 30dB Directional Coupler (07-002908)

The purpose of these couplers is to tap off known portions of RF signal from transmission lines and to combine them, for example through splitter units for different purposes (alarms/monitoring etc.), whilst maintaining an accurate 50Ω load to all ports/interfaces throughout the specified frequency range. They are known as directional couplers as they couple power from the RF mainline in one direction only.

Directional Coupler 07-002908 is configured to tap off 30dB.

07-002908 Specification

PARAMETER		SPECIFICATION
Frequency range		50 - 1000MHz
Insertion loss		<0.3dB
Coupling level		-30dB
Rejection		N/A
Weight		<200gms
Connectors		N type, female
Temperature range	operation	-20°C to +60°C
	storage	-40°C to +70°C

4.10.5.2. Switched Attenuator 0.25Watt, 0 - 30dB (10-000701)

10-000701 provides attenuation from 0 to 30dB in 2 dB steps. The attenuation is simply set using the four miniature toggle switches on the top of each unit. Each switch is clearly marked with the attenuation it provides, and the total attenuation in line is the sum of the values switched in. They are designed to maintain an accurate 50Ω impedance over their operating frequency at both input and output.

10-000701 Specification

PARAMETER		SPECIFICATION
Attenuation Values		0-30dB
Attenuation Steps		2, 4, 8 and 16dB
Power Handling		0.25 Watt
Attenuation Accuracy		± 1.0 dB
Frequency Range		DC to 1GHz
Impedance		50Ω
Connectors		SMA
VSWR		1.3:1
Weight		0.2kg
Temperature range	operation	-20°C to +60°C
	storage	-40°C to +70°C

4.10.5.3. Low Noise Amplifier (11-005401)

The 15dB gain low noise amplifier used in the unit is a double stage solid-state low noise amplifier. Class A circuitry is used throughout the units to ensure excellent linearity over a very wide dynamic range. The active devices are very moderately rated to provide a long trouble-free working life. There are no adjustments on these amplifiers, and in the unlikely event of a failure, the complete amplifier should be replaced. The amplifier is housed in an aluminium case (Iridite NCP finish) with SMA connectors for the RF input/output and a 9way D-type for DC and alarm outputs.

11-005401 Specification

PARAMETER		SPECIFICATION
Frequency range		380 - 500MHz
Bandwidth		<100MHz (as required, tuneable)
1dB compression point		>+20dBm
3rd order intercept		>+33dBm
Gain		>15.5dB (typical)
VSWR		better than 1.5:1
Input return loss		>14dB
Noise figure		<2.0dB (typical)
Connectors		SMA female
Supply		115mA at 12V DC
Temperature range	operational	-10°C to +60°C
	storage	-40°C to +70°C
Size		88 x 50 x 34mm (ex. connectors)
Weight		0.26kg

LNA 'D' Connector Pin-out details	
Connector pin	Signal
1	+ve input (10-24V)
2	GND
3	Alarm relay O/P bad
4	Alarm relay common
5	Alarm relay good
6	No connection
7	TTL voltage set
8	TTL alarm/0V (good)
9	O/C good/0V bad

9-Way Pin-Out Graphical Representation

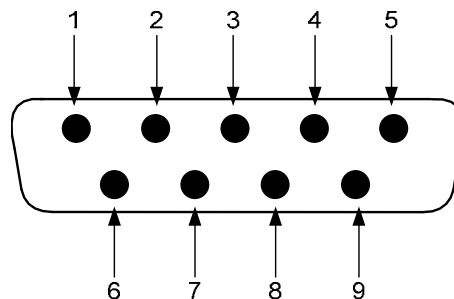

4.10.5.4. TETRA Power Amplifier 20W (12-016301)

This amplifier is a Class A 20W power amplifier from 380MHz to 470MHz in a 1 stage balanced configuration. It demonstrates a very high linearity and a very good input/output return loss (RL). It has built in a Current Fault Alarm Function.

It is housed in an aluminium case (Iridite NCP finish) with SMA connectors for the RF input/output and a D-Type connector for the power supply and the Current Fault Alarm Function. Note the large diameter DC power input pins (1 & 2) fitted to reduce volt-drop/arcing.

12-016301 Specification

PARAMETER		SPECIFICATION
Frequency range		380-470MHz
Small signal gain		23dB
Gain flatness		±1.7dB
I/O Return loss		>18dB
1dB compression point		43dBm
OIP3		55dBm
Supply voltage		24V DC
Supply current		3.8Amps (Typical)
Temperature range	operational	-10°C to +60°C
	storage	-20°C to +70°C
Weight		<2kg (no heatsink)

7-Way Connector Pin-out details	
Connector Pin	Signal
A1 (large pin)	+10-24V DC
A2 (large pin)	GND
1	Alarm relay common
2	TTL alarm/0V good
3	Alarm relay contact (bad)
4	Alarm relay contact (good)
5	O/C good/0V bad (TTL)

7-Way Connector Graphical Representation

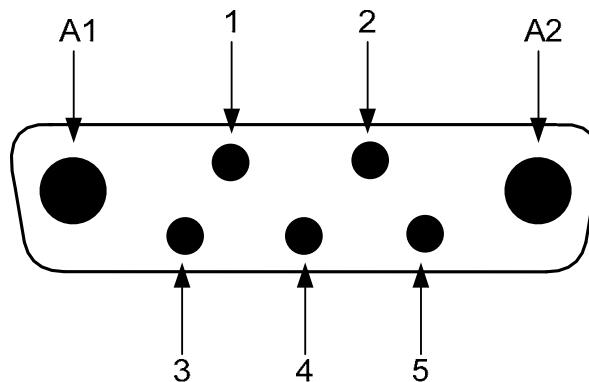

4.10.5.5. TETRA Power Amplifier 5W (12-021601)

Power amplifier 12-021601 is a multi-stage, solid state power amplifier. Class A circuitry is employed throughout the device to ensure excellent linearity over a wide dynamic frequency range. All the semiconductor devices are very conservatively rated to ensure low device junction temperatures and a long, trouble free working lifetime.

The power amplifier should require no maintenance over its operating life. Under no circumstances should the cover be removed or the side adjustments disturbed unless it is certain that the amplifier has failed; since it is critically aligned during manufacture and any re-alignment will require extensive test equipment.

The unit housing is an aluminium case (Iridite NCP finish) with SMA connectors for the RF input/output and a D-Type connector for the power supply and the Current Fault Alarm Function.

12-021601 Specification

PARAMETER		SPECIFICATION
Frequency range:		380-470MHz (as required)
Bandwidth:		10-40MHz (typical, tuned to spec.)
Maximum RF output:		5Watts
Gain:		30dB
1dB compression point:		+37.5dBm
3 rd order intercept point:		+50dBm
VSWR:		better than 1.5:1
Connectors:		SMA female
Supply:		1.9Amps @ 12V DC
Weight:		1kg (excluding heatsink)
Temperature range:	operational:	-10°C to +60°C
	storage:	-20°C to +70°C

7-Way Connector Pin-out details	
Connector Pin	Signal
A1 (large pin)	+10-24V DC
A2 (large pin)	GND
1	Alarm relay common
2	TTL alarm/0V good
3	Alarm relay contact (bad)
4	Alarm relay contact (good)
5	O/C good/0V bad (TTL)

7-Way Pin-Out Graphical Representation

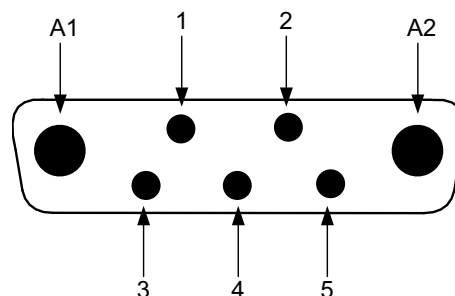

3.10.5.6. Low Power Amplifier (1Watt) (12-021801)

The low power amplifier used is a 1 stage balanced configuration, solid-state amplifier. Class A circuitry is used in the unit to ensure excellent linearity over a very wide dynamic range. The three active devices are very moderately rated to provide a long trouble-free working life.

Its housing is an aluminium case (Iridite NCP finish) with SMA connectors for the RF input/output and a D-Type connector for the power supply and the Current Fault Alarm Function.

There are no adjustments on this amplifier, and in the unlikely event of failure then the entire amplifier should be replaced.

12-021801 Specification

PARAMETER		SPECIFICATION
Temperature		-20 to +70 °C
Frequency Range		380 - 500 MHz
Small Signal Gain		15.5 +/- 0.5 dB
Gain Flatness		0.7 dB p-p Max
ΔGain vs. Temperature		0.7 dB Max
In RL		20 dB Min
Out RL		20 dB Min
Output Power @ 1dB Compression Point		30.5 dBm Min
Output 3 rd Order IP		41.5 dBm Min
Noise Figure		6 dB Max
DC Supply Voltage		10-15 Vdc
DC Supply Current		540 mA Max
Temperature range	operational:	-10°C to +60°C
	storage:	-40°C to +100°C
Weight:		<0.5 kg
Size:		110.5 x 66mm x 24.6mm

9-Way Connector Pin-outs	
Connector pin	Signal
1	+ve input (10-15V)
2	GND
3	Alarm relay O/P bad
4	Alarm relay common
5	Alarm relay good
6	No connection
7	TTL voltage set
8	TTL alarm/0V (good)
9	O/C good/0V bad

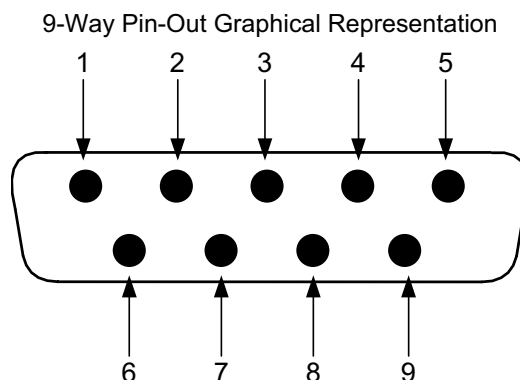

4.10.5.7. Automatic Gain Control

17-001101	AGC Detector Assembly
17-001105	AGC Detector Assembly (Logarithmic)
17-001201	AGC Attenuator Assembly

The three UHF Amplifier Shelves 80-301410 (Lowband, Midband and Highband) are each fitted with two differing types of Automatic Gain Control (AGC) system, one linear, and one logarithmic. The Downlink UHF paths are fitted with logarithmic detector (17-001105), and attenuator (17-001201) the Uplink UHF paths are fitted with linear detector (17-001101) and attenuator (17-001201)

The Automatic Gain Control system consists of two units, a detector/amplifier and an attenuator. The detector/amplifier unit is inserted in the RF path on the output of the power amplifier, and the attenuator is situated in the RF path before the amplification stage(s)

The attenuator comprises a 50Ω P.I.N diode, voltage-variable attenuator with a range of 3 to 30dB. The attenuation is controlled by a DC voltage which is derived from the associated detector controller board.

Normally the attenuator is at minimum attenuation. The detector/amplifier unit monitors the RF level being delivered by the power amplifier, and when a certain threshold is reached it begins to increase the value of the attenuator to limit the RF output to the (factory set) threshold. Therefore overloading of the power amplifier is avoided.

The factory set threshold is 1dB below the Enhancer 1dB compression point. Some adjustment of this AGC threshold level is possible, a 10dB range is mostly achieved. It is not recommended under any circumstances to adjust the AGC threshold to a level greater than the 1dB compression point as system degradation will occur.

The detector comprises of a 50Ω transmission line with a resistive tap which samples a small portion of the mainline power. The sampled signal is amplified and fed to a conventional half wave diode rectifier, the output of which is a DC voltage proportional to the RF input signal.

This DC voltage is passed via an inverting DC amplifier with integrating characteristics, to the output, which drives the attenuation control line of the corresponding AGC attenuator. This unit is fitted at some earlier point in the RF circuit.

For small signals, below AGC onset, the output control line will be close to 12V and the AGC attenuator will have minimum attenuation. As the signal level increases the control line voltage will fall, increasing the attenuator value and keeping the system output level at a constant value.

4.10.5.8. 24V Relay Dual Assembly (20-001602)

The General Purpose 24V Dual Relay Board (20-001602) allows the inversion of signals and the isolation of circuits. It is equipped with two dual pole change-over relays RL1 and RL2, with completely isolated wiring, accessed via screw terminals. Both relays are provided with polarity protection diodes and diodes for suppressing the transients caused by "flywheel effect" which can destroy switching transistors or induce spikes on neighbouring circuits. Its common use is to amalgamate all the alarm signals into one, volts-free relay contact pair for the main alarm system.

20-001602 Specification

PARAMETER		SPECIFICATION
Operating voltage		8 to 30V (floating earth)
Alarm Threshold		Vcc - 1.20 volt +15%
Alarm output relay contacts:		
Max. switch current		1.0Amp
Max. switch volts		120Vdc/60VA
Max. switch power		24W/60VA
Min. switch load		10.0µA/10.0mV
Relay isolation		1.5kV
Mechanical life		>2x10 ⁷ operations
Relay approval		BT type 56
Connector details		Screw terminals
Temperature range	operational	-10°C to +60°C
	storage	-20°C to +70°C

4.10.5.9. 12V Relay Assembly 80-008909

Relay Board (80-008909) allows the inversion of signals and the isolation of circuits. It is equipped with a single dual pole change-over relay RL1, with completely isolated wiring, accessed via a 15 way in-line connector.

The relay is provided with polarity protection diodes and diodes for suppressing the transients caused by "flywheel effect" which can destroy switching transistors or induce spikes on neighbouring circuits. It's common use is to amalgamate all the alarm signals into one, volts-free relay contact pair for the main alarm system. This relay board also carries an LED to serve as a "Status OK" indicator which is illuminated during normal operation.

80-008909 Specification

PARAMETER		SPECIFICATION
Operating voltage		8 to 30V (floating earth)
Alarm threshold		Vcc - 1.20 volt +15%
Alarm output relay contacts		
Max. switch current		1.0Amp
Max. switch volts		120Vdc/60VA
Max. switch power		24W/60VA
Min. switch load		10.0µA/10.0mV
Relay isolation		1.5kV
Mechanical life		>2x10 ⁷ operations
Relay approval		BT type 56
Connector details		Screw terminals
Temperature range	operational	-10°C to +60°C
	storage	-20°C to +70°C

4.10.5.10. Dual Diode Assembly (94-100004)

The purpose of these dual diode assemblies is to allow two DC voltage sources to be combined, so that the main DC rail within the equipment can be sourced from either a mains driven PSU, or externally through an XLR connector or from dual mains driven PSUs . They are very heavy-duty diodes and they prevent any reverse current from flowing back to their source or the alternative supply rail. Combining diodes such as these will also be used if the equipment is to be powered from external back-up batteries.

4.10.5.11. DC/DC Converter, 24V in, 12V 5A out (96-200024)

This unit it is an O.E.M high power device with a 5 amp @ 12V (60Watts) output capability used to derive a 12V fixed voltage power supply rail from a 24V supply. In the event of failure this unit should not be repaired, only replaced.

96-200024 Specification

PARAMETER		SPECIFICATION
Input Voltage range		18-28V DC
Output voltage		12V±0.5V
Max. current load		5.0 Amps
Temperature range	operation	-10°C to +60°C
	storage	-20°C to +70°C

4.11. UHF Midband Amplifier Shelf 80-301410

UHF Midband Amplifier Shelf 80-301410 provides the amplification stages for the UHF Midband paths, The unit is housed in a 4U, 19" rack mount shelf which is mounted in Rack 1

The Downlink UHF Midband signal is received at the port labelled "UHF DOWNLINK I/P" (Annotated A in section 4.11.4.2.). The signal passes through a switched attenuator providing 0 to 30 dB of RF signal attenuation and then into the amplification stage. The Downlink UHF Midband amplification stage is provided by two amplifier modules, the first is a 15dB gain Low Power Amplifier and the second is a 20W, 23dB gain power amplifier. Both amplification stages are straddled by an Automatic Gain Control assembly providing limiting to the output signals in the case of high input signals.

The input to the AGC detector is provided by the output of a 30dB tap. After leaving the Amplification/AGC stage the Downlink UHF Midband signal exits the Shelf via the port labelled "UHF DOWNLINK O/P" (B in section 4.11.4.2.).

The Uplink UHF Midband signal is received at the port labelled "UHF UPLINK I/P" (Annotated C in section 4.11.4.2.). The signal passes into a Low Noise Amplifier providing 15dB of gain and then into a switched attenuator providing 0 to 30 dB of RF signal attenuation. After the attenuator the Uplink UHF Midband signal passes into a second stage of amplification provided by a 5W, 30dB gain Power Amplifier, this amplification stage is straddled by an Automatic Gain Control assembly providing limiting to the output signals in the case of high input signals.

The Uplink UHF Midband signal exits the Shelf via the port labelled "UHF UPLINK O/P" (D in section 4.11.4.2.).

UHF Midband Amplifier Shelf 80-301410 is provided with a 24V DC input to power the amplifier modules within and those amplifier modules are configured to provide alarm status reports.

4.11.1. UHF Lowband Amplifier Shelf 80-301410 System Diagram

Drawing Number 80-301490 see section 4.10.1.

4.11.2. UHF Midband Amplifier Shelf 80-301410 Outline Drawing

Drawing Number 80-3014100 see section 4.10.2.

4.11.3. UHF Midband Amplifier Shelf 80-301410 Specification

Parameter	Specification
Downlink	
Downlink Passband	482.5 to 483.8MHz
Maximun gain	30dB
Gain Adjustment	0 to 30dB in 2dB steps
1dB Compression Point (P1dB)	+42.5dBm
ALC setting	1dB below P1dB
3 rd Order Intercept point	+53.5dBm
Uplink	
Uplink Passband	485.7 to 486.8MHz
Maximun gain	30dB
Gain Adjustment	0 to 30dB in 2dB steps
1dB Compression Point (P1dB)	+36.5dBm
ALC setting	+27dBm
3 rd Order Intercept point	+48.0dBm
Noise Figure	< 3.0dB
Mechanical Specification	
Mechanical	4U 19" Rack Mount
RF Connectors	N-Type Female
Alarm Interfaces	Local Alarms to SCADA Dry Contact with LED Indication per path
Power Supply	24V DC

4.11.4. UHF Lowband Amplifier Shelf 80-301410 Illustrations

4.11.4.1. Front View

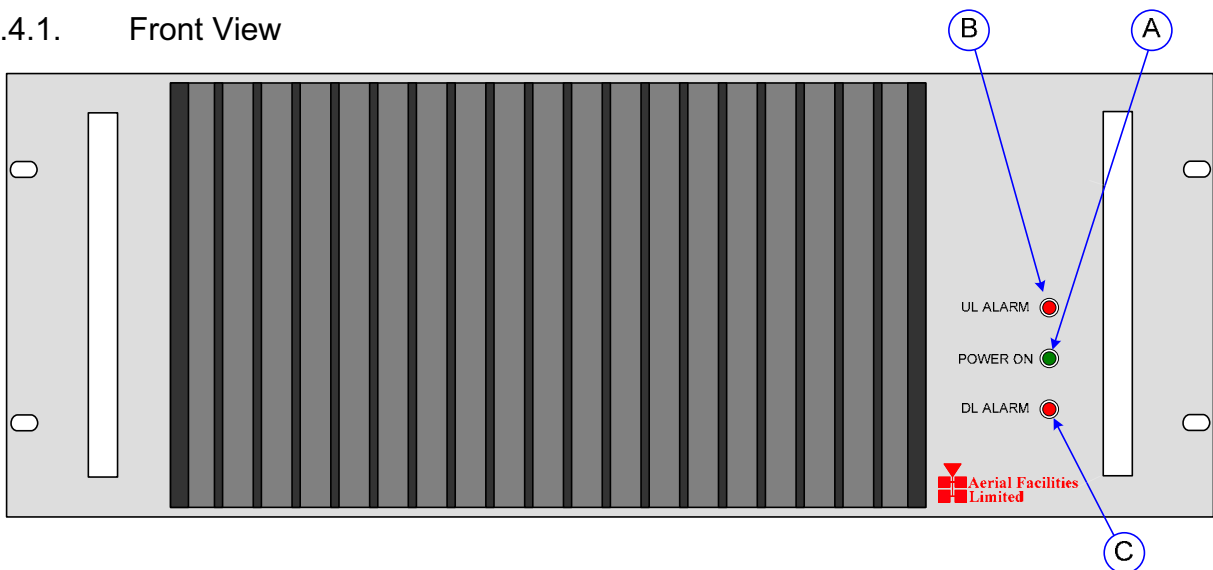

A	Green LED "Power On"
B	Red LED "Alarm" UHF Midband Uplink path
C	Red LED "Alarm" UHF Midband Downlink path

4.11.4.2. Rear View

N.B. UPLINK 485.7 - 486.8 MHz
DOWNLINK 482.5 - 483.8 MHz

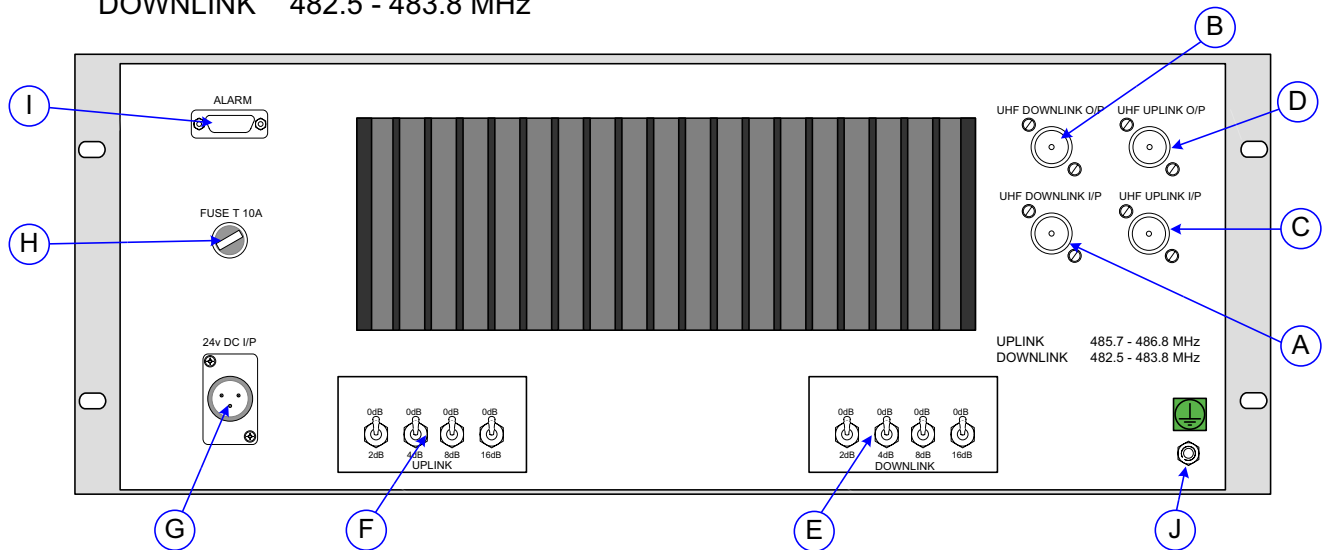

A	UHF Midband Downlink Input from Downlink Input Shelf 80-301407 Port 3
B	UHF Midband Downlink Output to Downlink Output Shelf 80-301408 Port C
C	UHF Midband Uplink Input from Uplink Input Shelf 80-301407 Port H
D	UHF Midband Uplink Output to Uplink Output Shelf 80-301407 Port 8
E	UHF Midband Downlink Switched Attenuator 0 to 30 dB
F	UHF Midband Uplink Switched Attenuator 0 to 30 dB
G	24V DC Input
H	10A Fuse for 24V DC Input
I	Alarm Output
J	Earth Connection

4.11.5. UHF Midband Amplifier Shelf 80-301410 Major Sub Components

The components for the UHF Midband Amplifier Shelf 80-301410 are exactly the same as those for UHF Lowband Amplifier Shelf 80-301410 in section 4.10.5

Section	Component Part	Component Part Description	Qty Per Assembly
4.10.5.1.	07-002908	30dB Directional Coupler	1
4.10.5.2.	10-000701	Switched Attenuator 0.25Watt, 0 - 30dB	2
4.10.5.3.	11-005401	Low Noise Amplifier	1
4.10.5.4.	12-016301	20W Power Amplifier	1
4.10.5.5.	12-021601	TETRA Power Amplifier 5W	1
4.10.5.6.	12-021801	TETRA Power Amplifier 1W	1
4.10.5.7.	17-001101	AGC Detector Assembly	1
	17-001105	AGC Detector Assembly (Logarithmic)	1
	17-001201	AGC Attenuator Assembly	2
4.10.5.8.	20-001602	24V Dual Relay Assembly	1
4.10.5.9.	80-008909	12V Relay Assembly	1
4.10.5.10.	94-100004	Dual Diode Assembly	1
4.10.5.11.	96-200024	DC/DC Converter	1

4.12. UHF Highband Amplifier Shelf 80-301410

UHF Highband Amplifier Shelf 80-301410 provides the amplification stages for the UHF Highband paths, The unit is housed in a 4U, 19" rack mount shelf which is mounted in Rack 1

The Downlink UHF Highband signal is received at the port labelled "UHF DOWNLINK I/P" (Annotated A in section 4.12.4.2.). The signal passes through a switched attenuator providing 0 to 30 dB of RF signal attenuation and then into the amplification stage. The Downlink UHF Highband amplification stage is provided by two amplifier modules, the first is a 15dB gain Low Power Amplifier and the second is a 20W, 23dB gain power amplifier. Both amplification stages are straddled by an Automatic Gain Control assembly providing limiting to the output signals in the case of high input signals.

The input to the AGC detector is provided by the output of a 30dB tap. After leaving the Amplification/AGC stage the Downlink UHF Highband signal exits the Shelf via the port labelled "UHF DOWNLINK O/P" (B in section 4.12.4.2.).

The Uplink UHF Highband signal is received at the port labelled "UHF UPLINK I/P" (Annotated C in section 4.12.4.2.). The signal passes into a Low Noise Amplifier providing 15dB of gain and then into a switched attenuator providing 0 to 30 dB of RF signal attenuation. After the attenuator the Uplink UHF Highband signal passes into a second stage of amplification provided by a 5W, 30dB gain Power Amplifier, this amplification stage is straddled by an Automatic Gain Control assembly providing limiting to the output signals in the case of high input signals.

The Uplink UHF Highband signal exits the Shelf via the port labelled "UHF UPLINK O/P" (D in section 4.12.4.2.).

UHF Highband Amplifier Shelf 80-301410 is provided with a 24V DC input to power the amplifier modules within and those amplifier modules are configured to provide alarm status reports.

4.12.1. UHF Highband Amplifier Shelf 80-301410 System Diagram

Drawing Number 80-301490 see section 4.10.1.

4.12.2. UHF Highband Amplifier Shelf 80-301410 Outline Drawing

Drawing Number 80-3014100 see section 4.10.2.

4.12.3. UHF Highband Amplifier Shelf 80-301410 Specification

Parameter	Specification
Downlink	
Downlink Passband	507.0 to 507.3MHz
Maximun gain	30dB
Gain Adjustment	0 to 30dB in 2dB steps
1dB Compression Point (P1dB)	+42.5dBm
ALC setting	1dB below P1dB
3 rd Order Intercept point	+53.5dBm
Uplink	
Uplink Passband	510.0 to 510.3MHz
Maximun gain	30dB
Gain Adjustment	0 to 30dB in 2dB steps
1dB Compression Point (P1dB)	+36.5dBm
ALC setting	+27dBm
3 rd Order Intercept point	+48.0dBm
Noise Figure	< 3.0dB
Mechanical Specification	
Mechanical	4U 19" Rack Mount
RF Connectors	N-Type Female
Alarm Interfaces	Local Alarms to SCADA Dry Contact with LED Indication per path
Power Supply	24V DC

4.12.4. UHF Highband Amplifier Shelf 80-301410 Illustrations

4.12.4.1. Front View

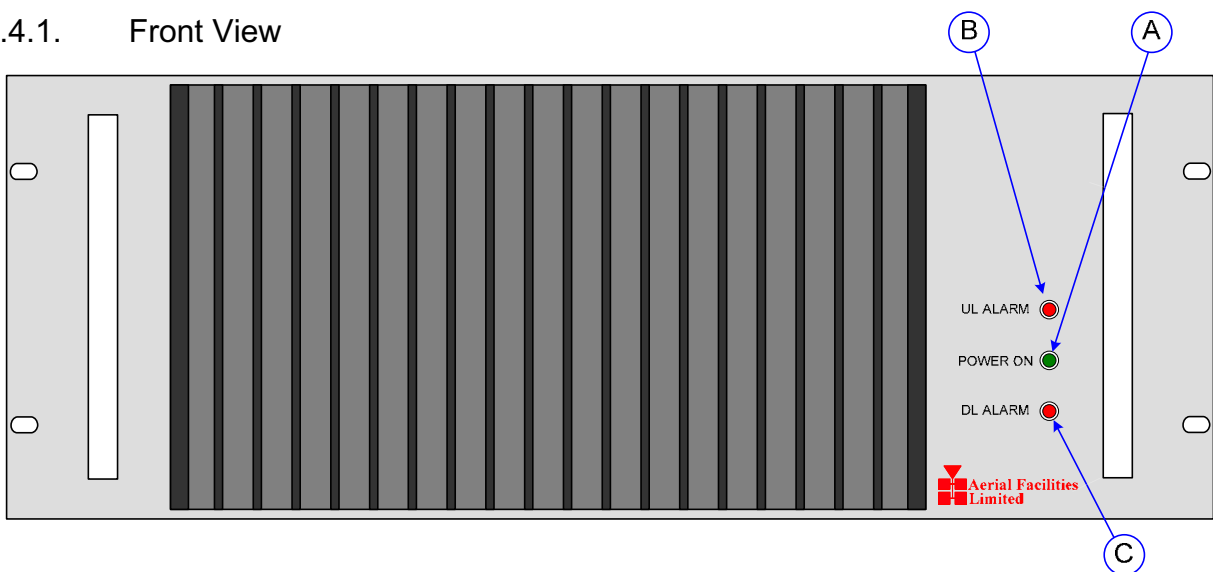

A	Green LED "Power On"
B	Red LED "Alarm" UHF Highband Uplink path
C	Red LED "Alarm" UHF Highband Downlink path

4.12.4.2. Rear View

N.B. UPLINK 510.0 - 510.3 MHz
DOWNLINK 507.0 - 507.3 MHz

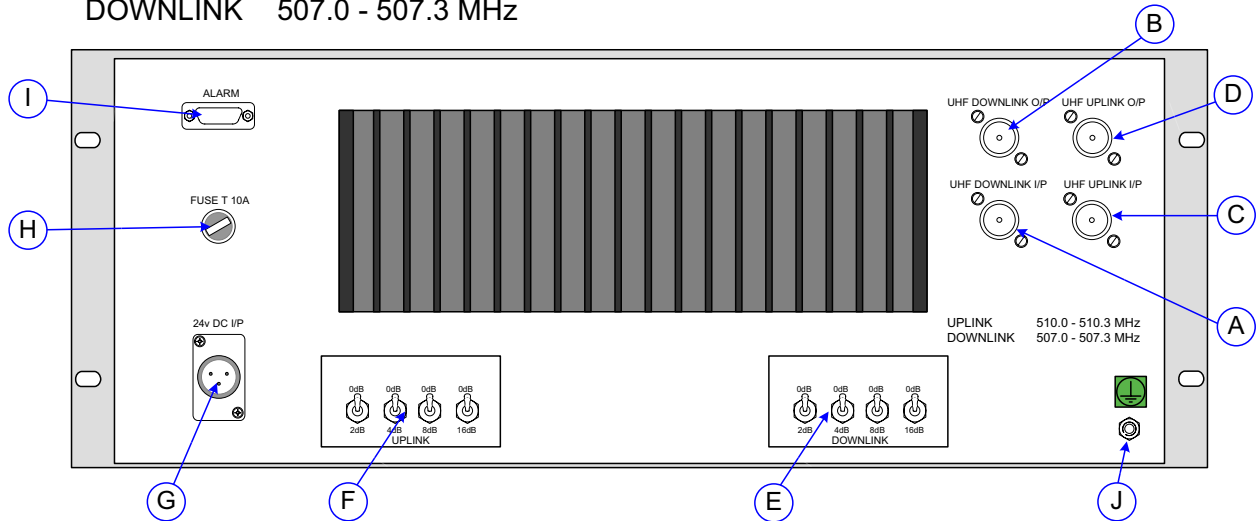

A	UHF Highband Downlink Input from Downlink Input Shelf 80-301407 Port 4
B	UHF Highband Downlink Output to Downlink Output Shelf 80-301408 Port D
C	UHF Highband Uplink Input from Uplink Input Shelf 80-301407 Port I
D	UHF Highband Uplink Output to Uplink Output Shelf 80-301407 Port 9
E	UHF Highband Downlink Switched Attenuator 0 to 30 dB
F	UHF Highband Uplink Switched Attenuator 0 to 30 dB
G	24V DC Input
H	10A Fuse for 24V DC Input
I	Alarm Output
J	Earth Connection

4.12.5. UHF Highband Amplifier Shelf 80-301410 Major Sub Components

The components for the UHF Highband Amplifier Shelf 80-301410 are exactly the same as those for UHF Lowband Amplifier Shelf 80-301410 in section 4.10.5

Section	Component Part	Component Part Description	Qty Per Assembly
4.10.5.1.	07-002908	30dB Directional Coupler	1
4.10.5.2.	10-000701	Switched Attenuator 0.25Watt, 0 - 30dB	2
4.10.5.3.	11-005401	Low Noise Amplifier	1
4.10.5.4.	12-016301	20W Power Amplifier	1
4.10.5.5.	12-021601	TETRA Power Amplifier 5W	1
4.10.5.6.	12-021801	TETRA Power Amplifier 1W	1
4.10.5.7.	17-001101	AGC Detector Assembly	1
	17-001105	AGC Detector Assembly (Logarithmic)	1
	17-001201	AGC Attenuator Assembly	2
4.10.5.8.	20-001602	24V Dual Relay Assembly	1
4.10.5.9.	80-008909	12V Relay Assembly	1
4.10.5.10.	94-100004	Dual Diode Assembly	1
4.10.5.11.	96-200024	DC/DC Converter	1

4.13. 800MHz Amplifier Shelf 80-301411

800MHz Amplifier Shelf 80-301411 provides the amplification stages for the 800 MHz paths, The unit is housed in an 8U, 19" rack mount shelf which is mounted in Rack 2

The Downlink 800MHz signal is received at the port labelled "DOWNLINK INPUT" (Annotated A in the picture in section 4.13.4.2.). The Downlink 800MHz path passes through a bandpass filter to remove out of band noise and then a switched attenuator providing 0 to 30 dB of RF signal attenuation, after the Attenuator the signal passes through the first of two amplification stages. This first stage is provided by a low noise amplifier which gives approximately 19dB of gain.

After the Low Noise Amplifier the Downlink 800MHz signal passes through the second amplification stage; the signal is first split into two equal paths and then each path is passed through a 20W power amplifier and then the two signal paths are re-combined. The second stage amplifiers are straddled by an Automatic Gain Control assembly providing limiting to the output signals in the case of high input signals.

After leaving the second stage amplifiers the Downlink 800MHz signal path passes through a second bandpass filter and exits the Shelf via the port labelled "DOWNLINK OUTPUT" (B in section 4.13.4.2.).

The Uplink 800MHz Signal is received at the port labelled "UPLINK INPUT" (C in section 4.13.4.2.). The Uplink 800MHz path passes through a bandpass filter to remove out of band noise and then into the first of two amplification stages, the first stage is provided by a low noise amplifier which gives approximately 19dB of gain; after leaving the Low Noise Amplifier the signal passes through a switched attenuator providing 0 to 30 dB of RF signal attenuation,

After leaving the switched attenuator the Uplink 800MHz path passes through the second stage of amplification which is provided by a 5W power amplifier giving approx. 30dB of gain; this second amplification stage is straddled by an Automatic Gain Control assembly providing limiting to the output signals in the case of high input signals.

After leaving the second amplification stage the Uplink 800MHz path passes through a second bandpass filter and exits the Shelf via the port labelled "UPLINK OUTPUT" (D in section 4.13.4.2.).

800MHz Amplifier Shelf 80-301411 is provided with a 24V DC input to power the amplifier modules within and those amplifier modules are configured to provide alarm status reports.

4.13.1. 800MHz Amplifier Shelf 80-301411 System Diagram

Drawing Number 80-301491

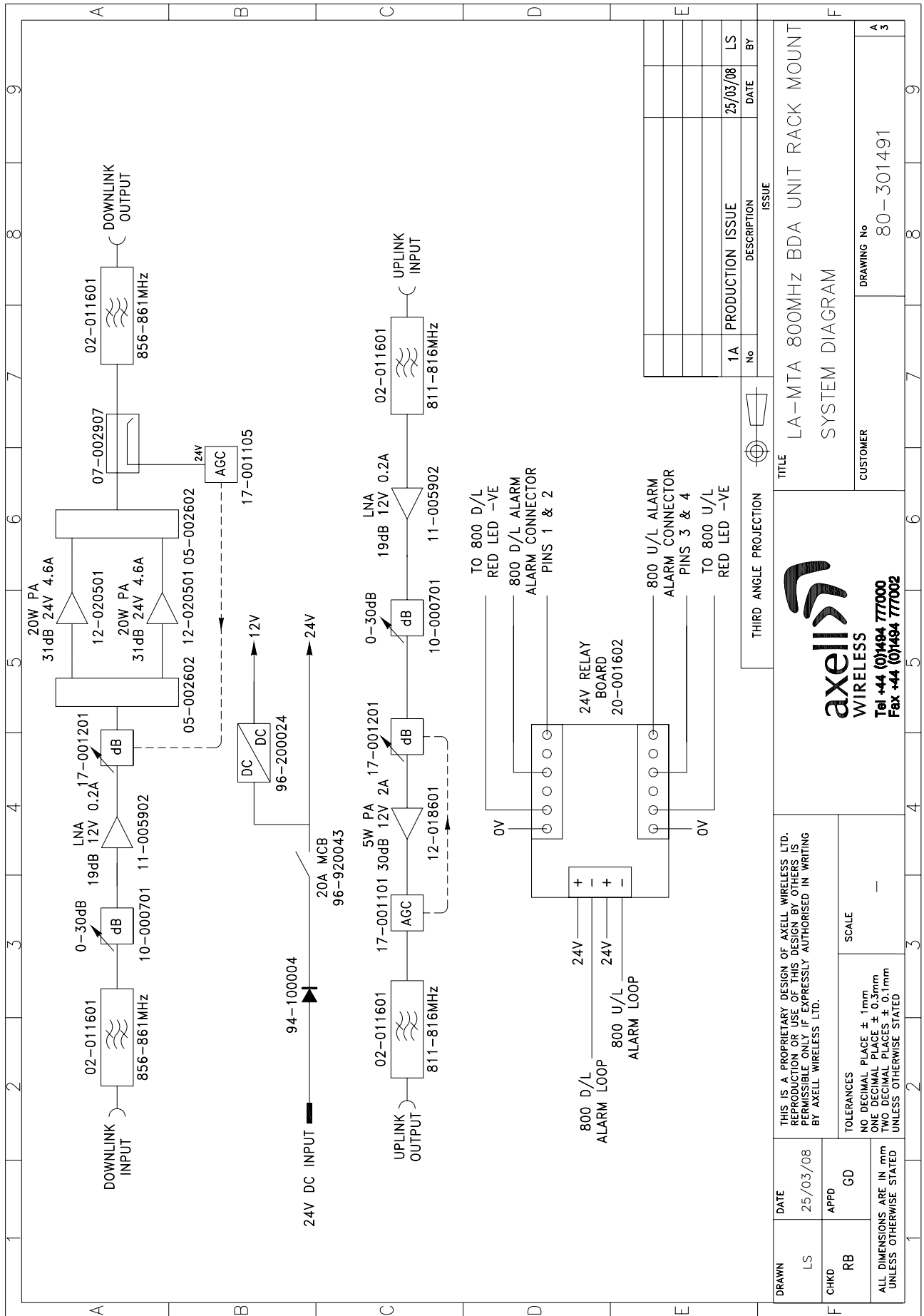

THIS IS A PROPRIETARY DESIGN OF AXELL WIRELESS LTD. REPRODUCTION OR USE OF THIS DESIGN BY OTHERS IS PERMISSIBLE ONLY IF EXPRESSLY AUTHORISED IN WRITING BY AXELL WIRELESS LTD.

TOLERANCES
NO DECIMAL PLACE ± 1mm
ONE DECIMAL PLACE ± 0.3mm
TWO DECIMAL PLACES ± 0.1mm
UNLESS OTHERWISE STATED

SCALE
—

DRWN	DATE	TITLE
LS	25/03/08	LA-MTA 800MHz BDA UNIT RACK MOUNT SYSTEM DIAGRAM
CHKD	APPD	CUSTOMER
RB	GD	DRAWING No
ALL DIMENSIONS ARE IN mm UNLESS OTHERWISE STATED		80-301491

4.13.2. 800MHz Amplifier Shelf 80-301411 Outline Drawing

Drawing Number 80-3014101

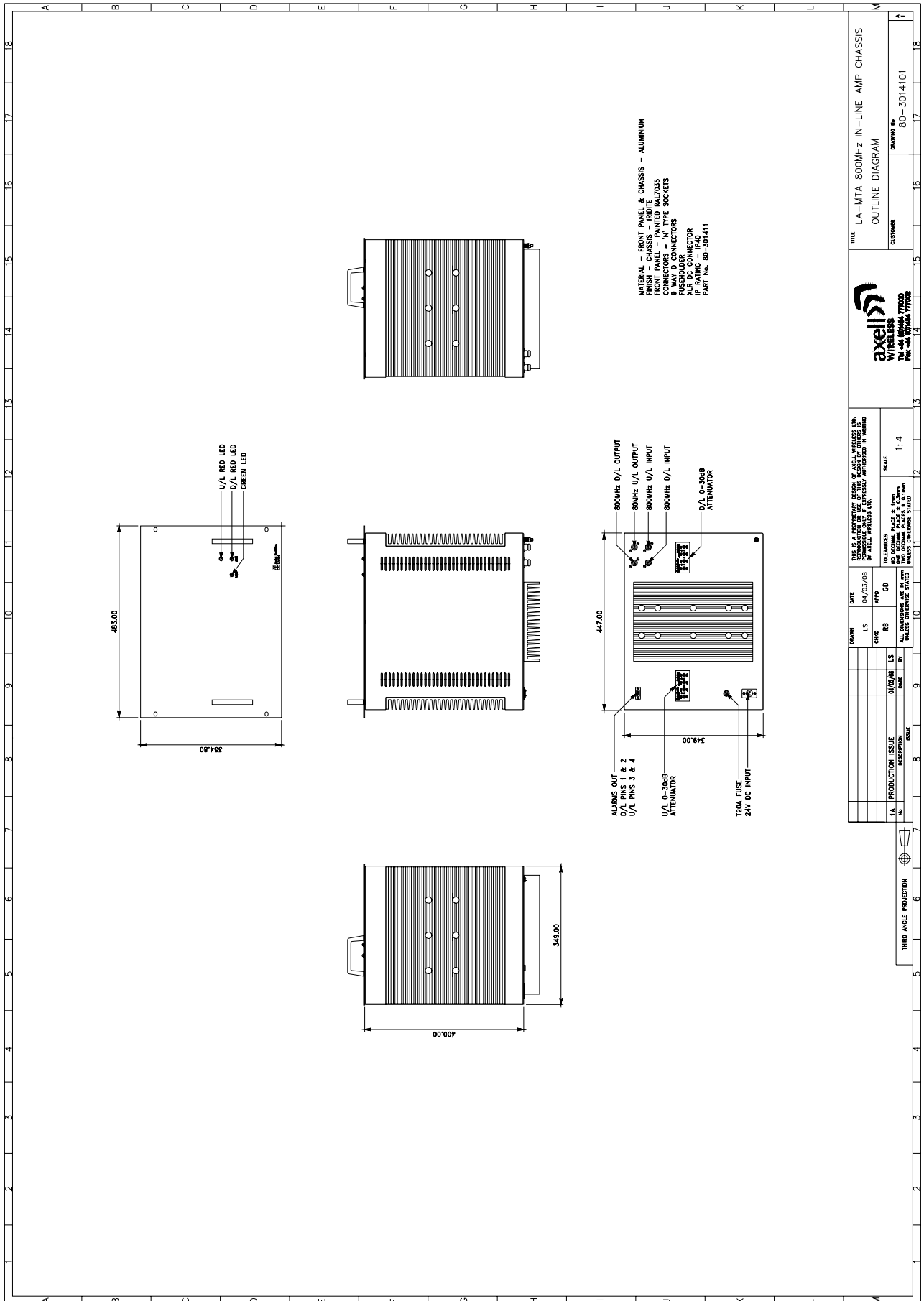

4.13.3. 800MHz Amplifier Shelf 80-301411 Specification

Parameter	Specification
Downlink	
Downlink Passband	856.0 to 861.0MHz
Maximun gain	30dB
Gain Adjustment	0 – 30dB in 2dB steps
1dB Compression Point (P1dB)	+44.0dBm
ALC setting	1dB below P1dB
3 rd Order Intercept point	+54.0dBm
Uplink	
Uplink Passband	811.0 to 816.0MHz
Maximun gain	30dB
Gain Adjustment	0 to 30dB in 2dB steps
1dB Compression Point (P1dB)	+36.0dBm
ALC setting	+27dBm
3 rd Order Intercept point	+46.0 dBm
Noise Figure	< 5.0 dB
Mechanical Specification	
Mechanical	8U 19" Rack Mount
RF Connectors	N-Type Female
Alarm Interfaces	Local Alarms to SCADA Dry Contact with LED Indication per path
Power Supply	24V DC

4.13.4. 800MHz Amplifier Shelf 80-301411 Illustrations

4.13.4.1. Front View

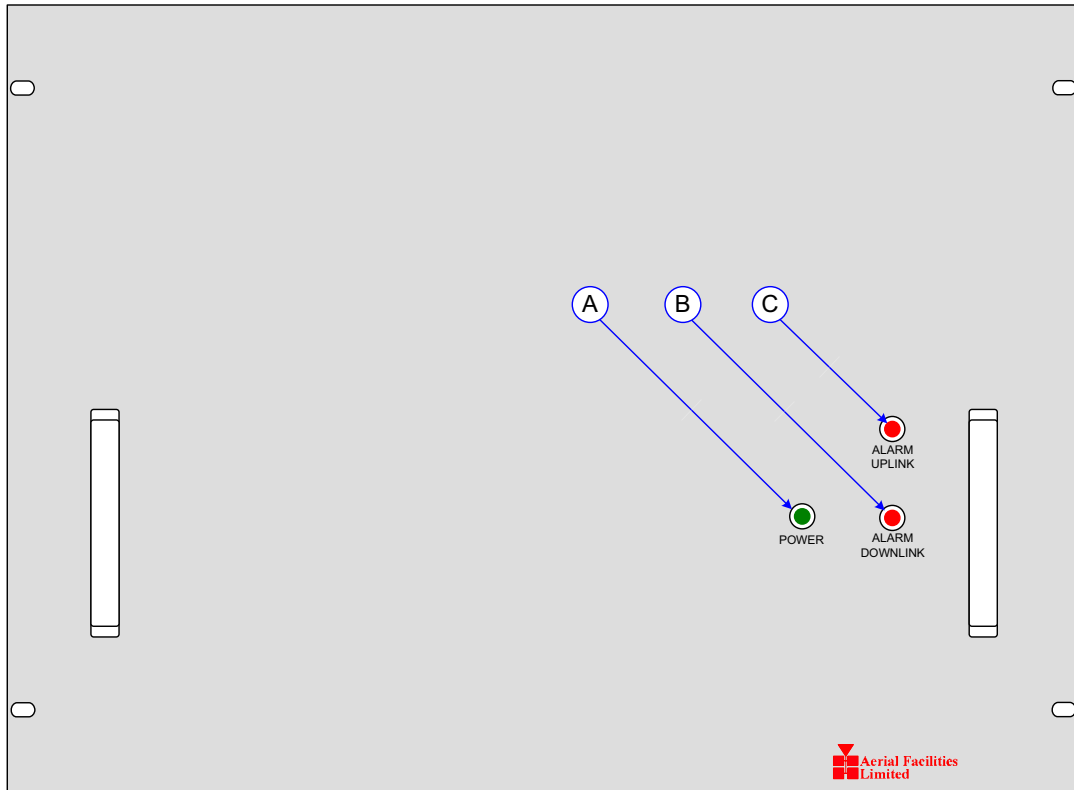

A	Green LED "Power On"
B	Red LED "Alarm" 800MHz Downlink path
C	Red LED "Alarm" 800MHz Uplink path

4.13.4.2. Rear View

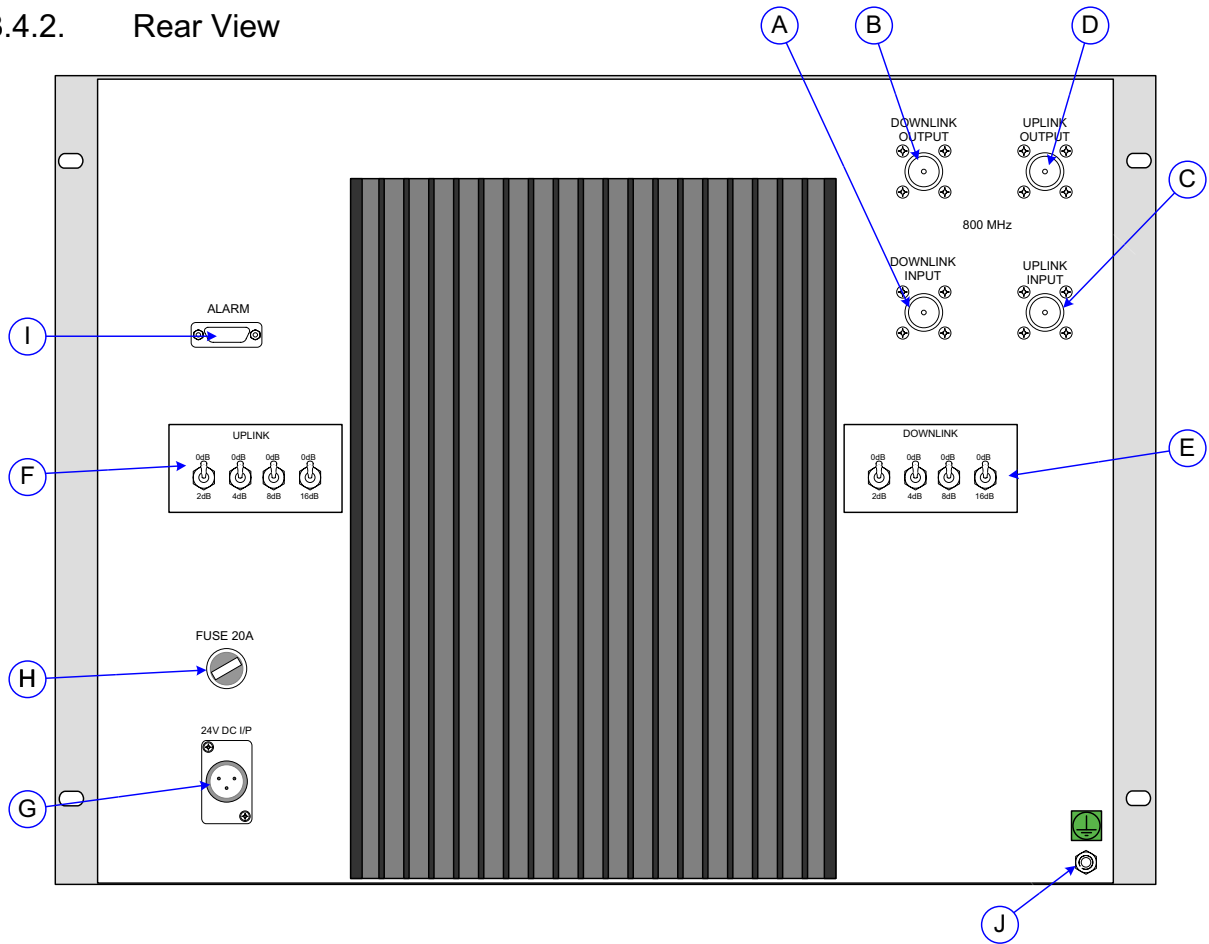

A	800MHz Downlink Input from Downlink Input Shelf 80-301407 Port 5
B	800MHz Downlink Output to Downlink Output Shelf 80-301408 Port E
C	800MHz Uplink Input from Uplink Input Shelf 80-301407 Port J
D	800MHz Uplink Output to Uplink Output Shelf 80-301407 Port 10
E	Downlink Switched Attenuator 0 to 30 dB
F	Uplink Switched Attenuator 0 to 30 dB
G	24V DC Input
H	20A Fuse for 24V DC Input
I	Alarm Output
J	Earth Connection

4.13.5. 800MHz Amplifier Shelf 80-301411 Major Sub Components

Section	Component Part	Component Part Description	Qty Per Assembly
4.13.5.1.	02-011601	Bandpass Filter	4
4.13.5.2.	05-002602	Splitter/Combiner, 20W	2
4.13.5.3.	07-002907	30dB Directional Coupler	1
4.13.5.4.	10-000701	Switched Attenuator 0.25Watt, 0 - 30dB	2
4.13.5.5.	11-005902	Low Noise Amplifier	1
4.13.5.6.	12-018601	5W Power Amplifier	1
4.13.5.7.	12-020501	20W Power Amplifier	2
4.13.5.8.	17-001101	AGC Detector Assembly	1
	17-001105	AGC Detector Assembly (Logarithmic)	1
	17-001201	AGC Attenuator Assembly	2
4.13.5.9.	20-001602	24V Relay Dual Assembly	1
4.13.5.10.	94-100004	Dual Diode Assembly	1
4.13.5.11.	96-200024	DC/DC Converter, 24V in, 12V 5A out	1

4.13.5.1. Bandpass Filter (02-011601)

The bandpass filters are multi-section designs with a bandwidth dependent upon the passband frequencies, (both tuned to customer requirements). The response shape is basically Chebyshev with a passband design ripple of 0.1dB. The filters are of combline design, and are carefully aligned during manufacture in order to optimise the insertion loss, VSWR and intermodulation characteristics of the unit. The tuned elements are silver-plated to reduce surface ohmic losses and maintain a good VSWR figure and 50Ω load at the input and output ports.

Being passive devices, the bandpass filters should have an extremely long operational life and require no maintenance. Should a filter be suspect, it is usually most time efficient to replace the module rather than attempt repair or re-tuning.

02-011601 Specification

PARAMETER		SPECIFICATION
Frequency Range	Downlink	856 to 861MHz
	Uplink	811 to 816MHz
Bandwidth	Downlink	5 MHz
	Uplink	5 MHz
Number of Sections		8
Insertion Loss		1.2 dB
VSWR		better than 1.2:1
Connectors		SMA
Power Handling		100W max
Temperature range	operation	-10°C to +55°C
	storage	-40°C to +70°C
Weight		3 kg (typical)

4.13.5.2. Splitter/Combiner (05-002602)

The Splitter/Combiner used is a device for accurately matching two or more RF signals to single or multiple ports, whilst maintaining an accurate 50Ω load to all inputs/outputs and ensuring that the VSWR and insertion losses are kept to a minimum. Any unused ports should be terminated with an appropriate 50Ω load.

Being passive devices, the splitters should have an extremely long operational life and require no maintenance. Should a unit be suspect, it is usually most time efficient to replace the whole module rather than attempt repair or re-tuning.

05-002602 Specification

PARAMETER		SPECIFICATION
Frequency Range		856 – 861MHz
Bandwidth		5MHz
Ports		3
Insertion loss		3.3dB
Return loss input & output		1.3:1
Impedance		50Ω
Isolation		>20dB
MTFB		>180,000 hours
Power rating	Splitting	20Watts
	Combining	0.5Watt
Connectors		SMA female
Weight		200g (approximately)
Size		54 x 44 x 21mm

4.13.5.3. 30dB Directional Coupler (07-002907)

The purpose of these couplers is to tap off known portions (in this case 30dB) of RF signal from transmission lines nband to combine them, for example through splitter units for different purposes (alarms/monitoring etc.), whilst maintaining an accurate 50Ω load to all ports/interfaces throughout the specified frequency range. They are known as directional couplers as they couple power from the RF mainline in one direction only.

07-002907 Specification

PARAMETER		SPECIFICATION
Frequency range		800 - 1000MHz
Insertion loss		<0.3dB
Coupling level		-30dB ±0.5dB
Rejection		N/A
Weight		<200g
Connectors		SMA, female
Temperature range	operation	-20°C to +60°C
	storage	-40°C to +70°C

4.13.5.4. Switched Attenuator 0.25Watt, 0 - 30dB (10-000701)

10-000701 provides attenuation from 0 to 30dB in 2 dB steps The attenuation is simply set using the four miniature toggle switches on the top of each unit. Each switch is clearly marked with the attenuation it provides, and the total attenuation in line is the sum of the values switched in. They are designed to maintain an accurate 50Ω impedance over their operating frequency at both input and output.

10-000701 Specification

PARAMETER		SPECIFICATION
Attenuation Values		0-30dB
Attenuation Steps		2, 4, 8 and 16dB
Power Handling		0.25 Watt
Attenuation Accuracy		± 1.0 dB
Frequency Range		DC to 1GHz
Impedance		50Ω
Connectors		SMA
VSWR		1.3:1
Weight		0.2kg
Temperature range	operation	-20°C to +60°C
	storage	-40°C to +70°C

4.13.5.5. Low Noise Amplifier (11-005902)

The Gallium-Arsenide low noise amplifier used in the unit is a double stage, solid-state low noise amplifier. Class A circuitry is used throughout the units to ensure excellent linearity and extremely low noise over a very wide dynamic range. The active devices are very moderately rated to provide a long trouble-free working life. There are no adjustments on these amplifiers, and in the unlikely event of a failure, then the complete amplifier should be replaced.

This amplifier features its own in-built alarm system which gives a volt-free relay contact type alarm that is easily integrated into any alarm system. There is a Current Fault Alarm Function, which indicates failure of each one or both RF transistors by a various alarm output options. The amplifier is housed in an aluminium case (Iridite NCP finish) with SMA connectors for the RF input/output and a 9way D-type for DC and alarm outputs.

11-005902 Specification

PARAMETER		SPECIFICATION
Frequency range		800 – 960MHz
Bandwidth		<170MHz
Gain		19.5dB (typical)
1dB compression point		+21dBm
OIP3		+33dBm
Input/output return loss		>20dB
Noise figure		1dB (typical)
Power consumption		190mA @ 24V DC
Supply voltage		10-24V DC
Connectors		SMA female
Temperature range	operational	-10°C to +60°C
	storage	-40°C to +70°C
Size		90 x 55 x 30.2mm
Weight		0.28kg

LNA 'D' Connector Pin-out details

Connector pin	Signal
1	+Ve input (10-24V)
2	GND
3	Alarm relay O/P bad
4	Alarm relay common
5	Alarm relay good
6	No connection
7	TTL voltage set
8	TTL alarm/0V (good)
9	O/C good/0V bad

9-Way Pin-Out Graphical Representation

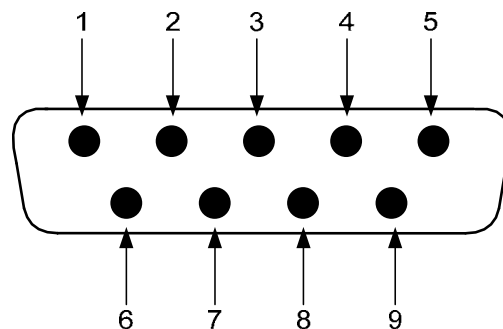

4.13.5.6. 5W Power Amplifier (12-018601)

This amplifier is a Class A 5W power amplifier from 800MHz to 960MHz in a 1 stage balanced configuration. It demonstrates a very high linearity and a very good input/output return loss (RL). It has built in a Current Fault Alarm Function.

Its housing is an aluminium case (Iridite NCP finish) with SMA connectors for the RF input/output and a D-Type connector for the power supply and the Current Fault Alarm Function.

12-018601 Specification

PARAMETER		SPECIFICATION
Frequency range		800-960MHz
Small signal gain		30dB
Gain flatness		±0.5dB
I/O Return loss		>20dB
1dB compression point		+37dBm
OIP3		+52dBm
Supply voltage		12V DC
Supply current		2.0Amps (typical)
Temperature range	operational	-10°C to +60°C
	storage	-20°C to +70°C
Weight		<2kg (no heatsink)

PA 7-Way Connector Pin-outs

Connector Pin	Signal
A1 (large pin)	+12V DC
A2 (large pin)	GND
1	Alarm relay common
2	TTL alarm/0V good
3	Alarm relay contact (bad)
4	Alarm relay contact (good)
5	O/C good/0V bad (TTL)

7-Way Connector Graphical Representation

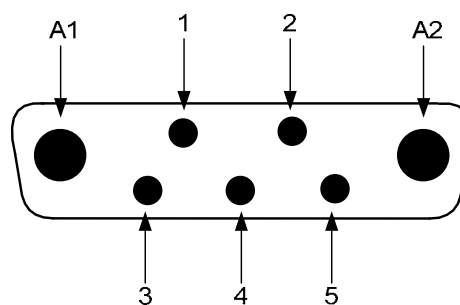

4.13.5.7. 20W Power Amplifier (12-020501)

This amplifier is a Class A 20W power amplifier from 800-960MHz in a 1 stage balanced configuration. It demonstrates a very high linearity and a very good input/output return loss (RL). It has built in a Current Fault Alarm Function.

Its housing is an aluminium case (Iridite NCP finish) with SMA connectors for the RF input/output and a D-Type connector for the power supply and the Current Fault Alarm Function.

12-020501 Specification

PARAMETER		SPECIFICATION
Frequency range		800-960MHz
Small signal gain		31.5dB
Gain flatness		±0.6dB
I/O Return loss		>18dB
1dB compression point		+43.5dBm
OIP3		+54dBm
Supply voltage		24V DC
Supply current		4.6Amps @12V(typical)
Temperature range	operational	-10°C to +60°C
	storage	-20°C to +70°C
Weight		<2kg (no heatsink)

PA 7-Way Connector Pin-outs

Connector Pin	Signal
A1 (large pin)	+24V DC
A2 (large pin)	GND
1	Alarm relay common
2	TTL alarm/0V good
3	Alarm relay contact (bad)
4	Alarm relay contact (good)
5	O/C good/0V bad (TTL)

7-Way Connector Graphical Representation

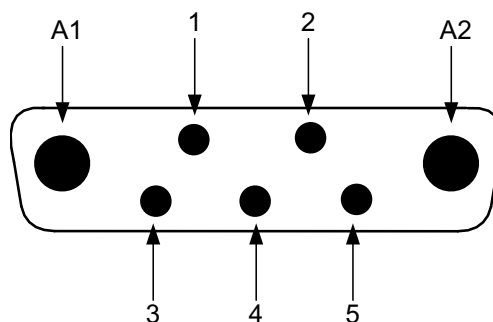

4.13.5.8. Automatic Gain Control

17-001101	AGC Detector Assembly
17-001105	AGC Detector Assembly (Logarithmic)
17-001201	AGC Attenuator Assembly

800MHz Amplifier Shelf 80-301411 is fitted with two differing types of Automatic Gain Control (AGC) system, one linear, and one logarithmic. The Downlink 800MHz path is fitted with logarithmic detector (17-001105), and attenuator (17-001201) the Uplink 800MHz path is fitted with linear detector (17-001101) and attenuator (17-001201)

The Automatic Gain Control system consists of two units, a detector/amplifier and an attenuator. The detector/amplifier unit is inserted in the RF path on the output of the power amplifier, and the attenuator is situated in the RF path before the amplification stage(s)

The attenuator comprises a 50Ω P.I.N diode, voltage-variable attenuator with a range of 3 to 30dB. The attenuation is controlled by a DC voltage which is derived from the associated detector controller board.

Normally the attenuator is at minimum attenuation. The detector/amplifier unit monitors the RF level being delivered by the power amplifier, and when a certain threshold is reached it begins to increase the value of the attenuator to limit the RF output to the (factory set) threshold. Therefore overloading of the power amplifier is avoided.

The factory set threshold is 1dB below the Enhancer 1dB compression point. Some adjustment of this AGC threshold level is possible, a 10dB range is mostly achieved. It is not recommended under any circumstances to adjust the AGC threshold to a level greater than the 1dB compression point as system degradation will occur.

The detector comprises of a 50Ω transmission line with a resistive tap which samples a small portion of the mainline power. The sampled signal is amplified and fed to a conventional half wave diode rectifier, the output of which is a DC voltage proportional to the RF input signal.

This DC voltage is passed via an inverting DC amplifier with integrating characteristics, to the output, which drives the attenuation control line of the corresponding AGC attenuator. This unit is fitted at some earlier point in the RF circuit.

For small signals, below AGC onset, the output control line will be close to 12V and the AGC attenuator will have minimum attenuation. As the signal level increases the control line voltage will fall, increasing the attenuator value and keeping the system output level at a constant value.

4.13.5.9. 24V Relay Dual Assembly (20-001602)

The General Purpose 24V Dual Relay Board (20-001602) allows the inversion of signals and the isolation of circuits. It is equipped with two dual pole change-over relays RL1 and RL2, with completely isolated wiring, accessed via screw terminals. Both relays are provided with polarity protection diodes and diodes for suppressing the transients caused by "flywheel effect" which can destroy switching transistors or induce spikes on neighbouring circuits. Its common use is to amalgamate all the alarm signals into one, volts-free relay contact pair for the main alarm system.

20-001602 Specification

PARAMETER		SPECIFICATION
Operating voltage		8 to 30V (floating earth)
Alarm Threshold		Vcc - 1.20 volt +15%
Alarm output relay contacts:		
Max. switch current		1.0Amp
Max. switch volts		120Vdc/60VA
Max. switch power		24W/60VA
Min. switch load		10.0µA/10.0mV
Relay isolation		1.5kV
Mechanical life		>2x10 ⁷ operations
Relay approval		BT type 56
Connector details		Screw terminals
Temperature range	operational	-10°C to +60°C
	storage	-20°C to +70°C

4.13.5.10. Dual Diode Assembly (94-100004)

The purpose of these dual diode assemblies is to allow two DC voltage sources to be combined, so that the main DC rail within the equipment can be sourced from either a mains driven PSU, or externally through an XLR connector or from dual mains driven PSUs . They are very heavy-duty diodes and they prevent any reverse current from flowing back to their source or the alternative supply rail. Combining diodes such as these will also be used if the equipment is to be powered from external back-up batteries.

4.13.5.11. DC/DC Converter, 24V in, 12V 5A out (96-200024)

This unit it is an O.E.M high power device with a 5 amp @ 12V (60Watts) output capability used to derive a 12V fixed voltage power supply rail from a 24V supply. In the event of failure this unit should not be repaired, only replaced.

96-200024 Specification

PARAMETER		SPECIFICATION
Input Voltage range		18-28V DC
Output voltage		12V±0.5V
Max. current load		5.0 Amps
Temperature range	operation	-10°C to +60°C
	storage	-20°C to +70°C

4.14

PSU 96-300064

96-300064 is an O.E.M. PSU – there are two housed in a 2U rack mount assembly at the bottom of Rack 1. We does not recommend any invasive procedures for these O.E.M. power supplies. In case of failure, they are not to be repaired, only replaced.

96-300064 Specification

AC Input Supply	
Voltages	110 or 220V nominal
	90 to 132 or 180 to 264V (absolute limits)
Frequency	47 to 63Hz
DC Output Supply:	
Voltage	24V DC (nominal)
	22 to 26V (absolute limits)
Maximum current	40A

5. INSTALLATION

5.1 Installation Record

When this equipment is initially commissioned, please use the equipment set-up record sheet in Appendix B. This will help both the installation personnel and Axell Wireless Ltd. should these figures be needed for future reference or diagnosis.

5.2 General Remarks

The size and weight of the equipment racks mean that they represent a significant topple hazard unless they are bolted to the floor through the mounting holes in the base of the unit. In the interests of safety this should be done before any electrical, RF, or optical connections are made.

The equipment must be located on a flat, level surface that is made from a material suitable for bearing the weight of the rack assembly. If the installer is in any doubt about the suitability of a site it is recommended that he consult with an appropriately qualified Structural Engineer.

It is important in determining the location of the rack within the room that space is allowed for access to the front and rear of the equipment. To enable maintenance to be carried out, the doors must be able to fully open.

The location must be served with a duct to allow the entry of cables into the rack.

5.3 Electrical Connections

The mains power supply is connected to the terminal strip located on the bulkhead at the rear of the equipment at floor level. It is recommended that the connection is made by a qualified electrician, who must satisfy himself that the supply will be the correct voltage and of sufficient capacity.

All electrical and RF connection should be completed and checked prior to power being applied for the first time.

Ensure that connections are kept clean and are fully tightened.

5.4 RF Connections

All RF connections are made to the cable termination, located on the bulkhead at the rear of the equipment at floor level. Care must be taken to ensure that the correct connections are made with particular attention made to the base station TX/RX ports. In the event that the base transmitter is connected to the RX output of the rack, damage to the equipment will be done if the base station transmitter is then keyed.

Ensure that connections are kept clean and are fully tightened.

5.5 Optical Connections

The optical input and output ports will be located on the appropriate E/O shelf as shown in the rack layout drawing and the system layout drawing. The ports are supplied with a green plastic cover, which must be removed prior to the connection of the fibre cable. Ensure that transmitter and receiver fibre cable are identified to prevent misconnection. At the master site, the fibre transmitters are in the downlink path with the receivers in the uplink. At the remote sites the fibre transmitters are in the uplink with the receivers in the downlink.

Ensure that connections are kept clean and are fully tightened.

5.6 Commissioning

Once all connections are made the equipment is ready for commissioning.

To commission the system the test equipment detailed in Section 6.2 will be required. Using the system diagrams and the end-to-end test specification, the equipment should be tested to ensure correct operation. Typical RF levels that are not listed in the end-to-end specification, such as input levels to the fibre transmitters are detailed in the maintenance section of this manual.

On initial power up the system alarm indicators on the front panels of the equipment should be checked. A red LED illuminated indicates a fault in that particular tray that must be investigated before proceeding with the commissioning. A green LED on each shelf illuminates, to indicate that the power supply is connected to the shelf

In the event that any part of the system does not function correctly as expected, check all connections to ensure that they are to the correct port, that the interconnecting cables are not faulty and that they are tightened. The majority of commissioning difficulties arise from problems with the interconnecting cables and connectors.

6. MAINTENANCE

6.1 Fault Finding

6.1.1 Quick Fault Checklist

All tunnel equipment is individually tested to specification prior to despatch. Failure of this type of equipment is not common. Experience has shown that a large number of fault conditions relating to tunnel installations result from simple causes often occurring as result of transportation, unpacking and installation. Below are listed some common problems which have resulted in poor performance or an indicated non-functioning of the equipment.

- Mains power not connected or not switched on.
- External connectors not fitted or incorrectly fitted.
- Internal connectors becoming loose due to transport vibration.
- Wiring becoming detached as a result of heavy handling.
- Input signals not present due to faults in the antenna and feeder system.
- Base transmissions not present due to fault at the base station.
- Modems fitted with incorrect software configuration.
- Changes to channel frequencies and inhibiting channels.
- Hand held radio equipment not set to repeater channels.
- Hand held radio equipment not set to correct base station.

6.1.2 Fault Isolation

In the event that the performance of the system is suspect, a methodical and logical approach to the problem will reveal the cause of the difficulty. The System consists of modules fitted in enclosed shelves within a rack mounted, environmentally protected enclosure.

Transmissions from the main base stations are passed through the system to the mobile radio equipment; this could be a handheld radio or a transceiver in a vehicle. This path is referred to as the downlink. The return signal path from the mobile radio equipment to the base station is referred to as the uplink.

The first operation is to check the alarms of each of the active units and determine that the power supplies to the equipment are connected and active.

This can be achieved remotely (via the volt free dry contact outputs to SCADA), or locally with the front panel LEDs. The green LED on the front panel should be illuminated, while any red alarm indicators should be off. If an Alarm is on, then that individual shelf must be isolated and individually tested against the original test specification.

The individual amplifier units within the shelf have a green LED showing through a hole in their piggy-back alarm board, which is illuminated if the unit is working correctly. If an amplifier is suspect, check the DC power supply to the unit. If no other fault is apparent use a spectrum analyser to measure the incoming signal level at the input and then after reconnecting the amplifier input, measure the output level. Consult with the system diagram to determine the expected gain and compare result.

In the event that there are no alarms on and all units appear to be functioning it will be necessary to test the system in a systematic manner to confirm correct operation.

6.1.3 Downlink

Confirm that there is a signal at the expected frequency and strength from the base station. If this is not present then the fault may lay outside the system. To confirm this, inject a downlink frequency signal from a known source at the Downlink input and check for the expected RF output.

If a signal is not received at the output it will be necessary to follow the downlink path through the system to find a point at which the signal is lost. The expected downlink output for the given input can be found in the end-to-end test specification.

6.1.4 Uplink

Testing the uplink involves a similar procedure to the downlink except that the frequencies used are those transmitted by the mobile equipment.

6.1.5 Checking service

Following the repair of any part of the system it is recommended that a full end-to-end test is carried out in accordance with the test specification and that the coverage is checked by survey.

It is important to bear in mind that the system includes a radiating cable network and base stations that may be faulty or may have been damaged.

6.1.6 Fault repair

Once a faulty component has been identified, a decision must be made on the appropriate course to carry out a repair. A competent engineer can quickly remedy typical faults such as faulty connections or cables. The exceptions to this are cable assemblies connecting bandpass filter assemblies that are manufactured to critical lengths to maintain a 50-ohm system. Care should be taken when replacing cables or connectors to ensure that items are of the correct specification. The repair of component modules such as amplifiers and bandpass filters will not usually be possible in the field, as they frequently require specialist knowledge and test equipment to ensure correct operation. It is recommended that items of this type are replaced with a spare unit and the faulty unit returned to Axell Wireless Ltd for repair.

6.1.7 Service Support

Advice and assistance with maintaining and servicing this system are available by contacting Axell Wireless Ltd

NOTE

Individual modules are not intended to be repaired on site and attempts at repair will invalidate active warranties. Company policy is that individual modules should be repaired by replacement. Axell Wireless Ltd. maintains a level of stock of most modules which can usually be despatched at short notice to support this policy.

6.2 Tools & Test Equipment

The minimum tools and test equipment needed to successfully service this Axell product are as follows-

Spectrum analyser	100kHz to 2GHz (Dynamic range = 90dB).
Signal Generator	30MHz to 2GHz (-120dBm to 0dBm o/p level).
Attenuator	20dB, 10W, DC-2GHz, (N male – N female).
Test Antenna	Yagi or dipole for operating frequency.
Digital multi-meter	Universal Volt-Ohm-Amp meter.
Test cable x 2	N male – N male, 2M long RG214.
Test cable x 2	SMA male – N male, 1m long RG223.
Hand tools	Philips #1&2 tip screwdriver. 3mm flat bladed screwdriver. SMA spanner and torque setter.

6.3 Care of Modules

6.3.1 General Comments

Many of the active modules contain semiconductor devices utilising MOS technology, which can be damaged by electrostatic discharge. Correct handling of such modules is mandatory to ensure their long-term reliability.

To prevent damage to a module, it must be withdrawn/inserted with care. The module may have connectors on its underside, which might not be visible to the service operative.

6.3.2 Module Removal (LNAs, general procedure)

The following *general* instructions should be followed to remove a module

- 1 Remove power to the unit
- 2 Remove all visible connectors (RF, DC & alarm)
- 3 Release module retaining screws.
- 4 Slowly but firmly, pull the module straight out of its position. Take care not to twist/turn the module during withdrawal. (When the module is loose, care may be needed, as there may be concealed connections underneath).

6.3.3 Module Replacement (general)

- 1 Carefully align the module into its location then slowly push the module directly straight into its position, taking care not to twist/turn it during insertion.
- 2 Reconnect all connectors, RF, alarm, power etc., (concealed connectors may have to be connected first).
- 3 Replace retaining screws (if any).
- 4 Double-check all connections before applying power.

6.3.4 Power Amplifiers

- 1) Remove power to the unit. (Switch off at mains/battery, or remove DC in connector)
- 2) Remove alarm wires from alarm screw terminal block or disconnect multi-way alarm connector.

- 3) Carefully disconnect the RF input and output coaxial connectors (usually SMA)
If alarm board removal is not required, go to step 5.
- 4) There is (usually) a plate attached to the alarm board which fixes it to the amplifier, remove its retaining screws and the alarm board can be withdrawn from the amplifier in its entirety. On certain types of amplifier the alarm board is not mounted on a dedicated mounting plate; in this case it will have to firstly be removed by unscrewing it from the mounting pillars, in most cases, the pillars will not have to be removed before lifting the amplifier.
- 5) If the amplifier to be removed has a heatsink attached, there may be several different ways it can have been assembled. The most commonly used method, is screws through the front of the heatsink to threaded screw holes (or nuts and bolts), into the amplifier within the main case. If the heatsink is mounted on the rear of the main case (e.g., against a wall in the case of wall mounted enclosures), then the fixing method for the heatsink will be from within the case, (otherwise the enclosure would have to be removed from the wall in order to remove the heatsink).

When the heatsink has been removed, the amplifier may be unscrewed from the main casing by its four corner fixings and gently withdrawn.

Fitting a new power amplifier module will be the exact reverse of the above.

Note Do not forget to apply fresh heatsink compound to the heatsink/main case joint and also between the amplifier and the main case.

6.3.5 Low Power Amplifier Replacement

- 1 Disconnect the mains power supply and disconnect the 24V dc supply connector for the LPA.
- 2 Disconnect the RF input and output cables from the LPA.
- 3 Disconnect the alarm connector.
- 4 Remove the alarm monitoring wires from (D type connector) pins 9 and 10.
- 5 Remove the LPA module by removing the four retaining screws, replace with a new LPA module and secure it with the screws.
- 6 Connect the RF cables to the LPA input and output connectors. Reconnect the wires to the alarm board connector pins 9 and 10.
- 7 Reconnect the DC supply connector and turn the mains switch on.

Note Tighten SMA connectors using only a dedicated SMA torque spanner. If SMA connectors are over-tightened, irreparable damage will occur. . Do not use adjustable pliers to loosen/tighten SMA connectors.

Also take care not to drop or knock the module as this can damage (or misalign in the case of tuned passive modules) sensitive internal components. Always store the modules in an environmentally friendly location

6.3.6 Module Transportation

To maintain the operation, performance and reliability of any module it must be stored and transported correctly. Any module not installed in a whole system must be kept in an anti-static bag or container. These bags or containers are normally identified by being pink or black, and are often marked with an ESD label. Any module sent back to Axell for investigation/repair must be so protected. Please contact Axell's quality department before returning a module.

Appendix A

A.1. Glossary of Terms used in this document

Cell Enhancer or Repeater	A Radio Frequency (RF) amplifier which can simultaneously amplify and re-broadcast Mobile Station (MS) and Base Transceiver Station (BTS) signals.
Band Selective Repeater	A Cell Enhancer designed for operation on a range of channels within a specified frequency band.
Channel Selective Repeater	A Cell Enhancer, designed for operation on specified channel(s) within a specified frequency band. Channel frequencies may be factory set or on-site programmable.
AC	Alternating Current
AGC	Automatic Gain Control
BBU	Battery Backup Unit
BTS	Base Transceiver Station
CEMS	Coverage Enhanced Management System
C/NR	Carrier-to-Noise Ratio
DC	Direct Current
Downlink (D/L)	RF signals TX from the BTS to the Master Site
FO	Fibre Optic
GND	Ground
ID	Identification Number
LED	Light Emitting Diode
LNA	Low Noise Amplifier
LPA	Low Power Amplifier
MOU	Master Optical Unit
M.S.	Mobile Station
MTBF	Mean Time Between Failures
N/A	Not Applicable
N/C	No Connection
OFR	On Frequency Repeater
OIP3	Output Third Order Intercept Point
P1dB	1dB Compression Point
PA	Power Amplifier
RF	Radio Frequency
RSA	Receiver/Splitter Amplifier
RX	Receiver
S/N	Serial Number
TX	Transmitter
Uplink (U/L)	RF signals transmitted from the MS to the BTS
VSWR	Voltage Standing Wave Ratio
WDM	Wave division multiplex

A.2. Key to Drawing Symbols used in this document

1		2		3		4		5		6		7		8		9					
HUBS FIBRE MAIN HUB EXPANSION HUB TAPPER/COUPLER		COUPLERS 100dB COUPLER 6 dB DIRECTIONAL COUPLER 100dB DIRECTIONAL COUPLER 6dB DIRECTIONAL COUPLER DIRECTIONAL COUPLER CROSS BAND COUPLER		CABLES 8/FIBRE OPTIC CABLE/LINK 24/FIBRE OPTIC CABLE/LINK JUMPER CABLE 1/2" RADIATING CABLE CAT 5 CABLE CO-AX CABLE 1/2" DIA CO-AX CABLE 7/8" DIA		SPLITTERS HYBRID SPLITTER SPLITTER		ANTENNAS OMNI ANTENNA YAGI ANTENNA FLAT PLATE ANTENNA (MOUNTED AT HIGH LEVEL) DIRECTIONAL ANTENNA ANTENNA REMOTE ANTENNA UNIT PANEL ANTENNA BLADE ANTENNA		SIGNAL KEY • = READING POSITION 602 = BCCH (BROADCAST CONTROL CHANNEL) 22 = BSIC (BASIC SITE IDENTITY CODE) -82 = ACCEPTABLE SIGNAL LEVEL (dbm) -83 = BELOW ACCEPTABLE SIGNAL LEVEL (dbm) -72 = ACCEPTABLE SIGNAL LEVEL (dbm) -73 = BELOW ACCEPTABLE SIGNAL LEVEL (dbm)		MISC AC TO DC PSU DC TO DC CONVERTER FUSE N.O. (CLEAR CONTACT) RELAY COM N.C. (FILLED CONTACT)		MISC AMPLIFIER ATTENUATOR (VARIABLE) ATTENUATOR (FIXED) A.G.C. MONITORING CONTROLLER MODEM BI-DIRECTIONAL AMPLIFIER (CELL ENHANCER) DUMMY LOAD LOCAL OSCILLATOR		MISC BAND PASS FILTER CAVITY RESONATOR NOTCH FILTER ISOLATOR HYBRID COMBINER EARTH STUD LEEKY FEEDER R.S.A. Outputs to receivers		MISC BASE TRANSMITTER STATION CHANNEL MODULE FIBRE-OPTIC MODULATOR FIBRE-OPTIC DEMODULATOR PLUG & SOCKET SOCKET PLUG FIBRE OPTIC CONNECTOR FC/APC		ISSUE No. DESCRIPTION DATE BY 2B TEXT CORRECTION 28/07/04 PL 2A ECN3165 26/01/04 PL 1A BLADE ANTENNA ADDED 21/06/00 PL AA ORIGINAL 23/05/00 PL	
THIRD ANGLE PROJECTION																					
TITLE AFL - STANDARD SYMBOLS																					
CUSTOMER Aerial Facilities Limited England Tel : 01494 777000 Fax : 01494 777002																					
SCALE NTS																					
TOLERANCES NO DECIMAL PLACE ± 1mm ONE DECIMAL PLACE ± 0.3mm TWO DECIMAL PLACES ± 0.1mm UNLESS OTHERWISE STATED																					
DRAWN PL 10/05/00		DATE 10/05/00		THIS IS A PROPRIETARY DESIGN OF AERIAL FACILITIES LTD. REPRODUCTION OR USE OF THIS DESIGN BY OTHERS IS PERMISSIBLE ONLY IF EXPRESSLY AUTHORISED IN WRITING BY AERIAL FACILITIES LTD.		SCALE NTS		SCALE NTS		CUSTOMER Aerial Facilities Limited England Tel : 01494 777000 Fax : 01494 777002		ISSUE No. DESCRIPTION DATE BY 2B TEXT CORRECTION 28/07/04 PL 2A ECN3165 26/01/04 PL 1A BLADE ANTENNA ADDED 21/06/00 PL AA ORIGINAL 23/05/00 PL		STANDARD EXCEPT FOR AIRPORTS (SEE BELOW)		STANDARD FOR ALL AIRPORTS					
DRAWN MB		DATE 10/05/00		THIS IS A PROPRIETARY DESIGN OF AERIAL FACILITIES LTD. REPRODUCTION OR USE OF THIS DESIGN BY OTHERS IS PERMISSIBLE ONLY IF EXPRESSLY AUTHORISED IN WRITING BY AERIAL FACILITIES LTD.		SCALE NTS		SCALE NTS		CUSTOMER Aerial Facilities Limited England Tel : 01494 777000 Fax : 01494 777002		ISSUE No. DESCRIPTION DATE BY 2B TEXT CORRECTION 28/07/04 PL 2A ECN3165 26/01/04 PL 1A BLADE ANTENNA ADDED 21/06/00 PL AA ORIGINAL 23/05/00 PL		STANDARD EXCEPT FOR AIRPORTS (SEE BELOW)		STANDARD FOR ALL AIRPORTS					
DRAWN MB		DATE 10/05/00		THIS IS A PROPRIETARY DESIGN OF AERIAL FACILITIES LTD. REPRODUCTION OR USE OF THIS DESIGN BY OTHERS IS PERMISSIBLE ONLY IF EXPRESSLY AUTHORISED IN WRITING BY AERIAL FACILITIES LTD.		SCALE NTS		SCALE NTS		CUSTOMER Aerial Facilities Limited England Tel : 01494 777000 Fax : 01494 777002		ISSUE No. DESCRIPTION DATE BY 2B TEXT CORRECTION 28/07/04 PL 2A ECN3165 26/01/04 PL 1A BLADE ANTENNA ADDED 21/06/00 PL AA ORIGINAL 23/05/00 PL		STANDARD EXCEPT FOR AIRPORTS (SEE BELOW)		STANDARD FOR ALL AIRPORTS					

A.3. EC Declaration of Conformity



In accordance with BS EN ISO/IEC 17050-1&-2:2004

Aerial Facilities Limited
Aerial House
Asheridge Road
Chesham
Buckinghamshire HP5 2QD
United Kingdom

CE0086

DECLARES, UNDER OUR SOLE RESPONSIBILITY THAT THE FOLLOWING PRODUCT:
PRODUCT DESCRIPTION AND PART NO[S]
In-Line Bi-Directional Amplifier (Wall Mount) 80-301401
In-Line Bi-Directional Amplifier (Rack Mount) 80-301406

IN ACCORDANCE WITH THE FOLLOWING DIRECTIVES:

1999/5/EC The Radio & Telecommunications Terminal Equipment Directive Annex V
and its amending directives

HAS BEEN DESIGNED AND MANUFACTURED TO THE FOLLOWING STANDARD[S] OR
OTHER NORMATIVE DOCUMENT[S]:

BS EN 60950 Information technology equipment.
Safety. General requirements

ETS EN 301 489-1 EMC standard for radio equipment and services.
Part 1. Common technical requirements

I hereby declare that the equipment named above has been designed to comply with the relevant sections of the above referenced specifications. The unit complies with all essential requirements of the Directives.

SIGNED

A handwritten signature in black ink, appearing to read "B.S. Barton".

B. S. BARTON
OPERATIONS DIRECTOR

DATE: 21/01/2008

Registered Office: Aerial House, Asheridge Road, Chesham, Buckinghamshire, HP5 2QD England Registered No. 4042808 (England)
www.axellwireless.com

A.4. Amendment List Record Sheet

Issue No.	Date	Incorporated by	Page Nos. Amended	Reason for new issue
A	21/01/2008	AJS		Draft
1	13/06/2008	AJS		Issue

Document Ref. 80-301401HBKM

APPENDIX B

B.1. INITIAL EQUIPMENT SET-UP CALCULATIONS

GENERAL INFORMATION			
Site Name		Client Name	
Date		AWL Equip. Model No.	

ANTENNA SYSTEMS				
	Model	Gain	Azimuth	Comments
A - Service Antenna				
B - Donor Antenna				
	Type	Loss	Length	Comments
C - Service Feeder				
D - Donor Feeder				

INITIAL PARAMETERS	
E - CE Output Power	dBm
F - Antenna Isolation	dB
G - Input signal level from donor BTS	dBm
Operating Voltage	V

DOWNLINK CALCULATIONS		
Parameter	Comments	Value
Input signal level (G)		dBm
CE max. o/p power (E)		dBm
Gain setting	E - G	dB
Isolation required	(Gain + 10dB)	dB
Service antenna gain (A)		dB
Service antenna feeder loss (C)		dB
Effective radiated power (ERP)	E+A-C	dBm
Attenuator setting	CE gain-gain setting	dB

If the input signal level in the uplink path is known and steady, use the following calculation table to determine the gain setting. If the CE features Automatic Gain Control the attenuator should be set to zero and if not, then the attenuation setting for both uplink and downlink should be similar.

UPLINK CALCULATIONS		
Parameter	Comments	Value
Input signal level		dBm
CE max. o/p power (E)		dBm
Gain setting		dB
Required isolation		dB
Donor antenna gain (B)		dB
Donor antenna feeder loss (D)		dB
Effective radiated power (ERP)	E+B-D	dBm
Attenuator setting	(CE gain-gain setting)	dB