

SMR 700 800 High Power

PS NFPA Signal Booster Class A

COBHAM

User Manual – 00068CDUM Rev. 2.3

The most important thing we build is trust

This manual is relevant for the following Class A booster models:

D-MBR 3707/3708 PS NFPA, D-SBR 3707 PS NFPA, D-SBR 3708 PS NFPA, D-SBR 4008 PS NFPA



Copyright © 2016 Axell Wireless Limited trading as Cobham Wireless

All rights reserved.

No part of this document may be copied, distributed, transmitted, transcribed, stored in a retrieval system, or translated into any human or computer language without the prior written permission of Axell Wireless Limited trading as Cobham Wireless.

The manufacturer has made every effort to ensure that the instructions contained in this document are adequate and free of errors and omissions. The manufacturer will, if necessary, explain issues which may not be covered by this document. The manufacturer's liability for any errors in the document is limited to the correction of errors and the aforementioned advisory services.

This document has been prepared to be used by professional and properly trained personnel, and the customer assumes full responsibility when using them. The manufacturer welcomes customer comments as part of the process of continual development and improvement of the documentation in the best way possible from the user's viewpoint. Please submit your comments to the nearest Cobham Wireless sales representative.

Contact Information

| | |
|--|--|
| Headquarters | Axell Wireless trading as Cobham Wireless Aerial House, Asheridge Road Chesham, Buckinghamshire HP5 2QD, United Kingdom Tel: +44 1494 777000 Fax: +44 1494 777002 |
| Commercial inquiries | cw.coverage@cobham.com |
| Website | www.cobham.com/wireless |
| Support issues | cw.support@cobham.com |
| Technical Support Line, English speaking | +44 1494 777 747 |

About This Manual

This Product Manual provides the following information:

- Description of the Repeater unit
- Procedures for setup, configuration and checking the proper operation of the unit
- Maintenance and troubleshooting procedures

For whom it is intended

This Product Manual is intended for experienced technicians and engineers. It is assumed that the customers installing, operating, and maintaining Cobham Wireless Repeaters are familiar with the basic functionality of Repeaters.

Notice

Confidential - Authorized Customer Use

This document may be used in its complete form only and is solely for the use of Cobham Wireless employees and authorized Cobham Wireless channels or customers. The material herein is proprietary to Cobham Wireless. Any unauthorized reproduction, use or disclosure of any part thereof is strictly prohibited.

All trademarks and registered trademarks are the property of their respective owners.

Disclaimer of Liability

Contents herein are current as of the date of publication. Cobham Wireless reserves the right to change the contents without prior notice. The information furnished by Cobham Wireless in this document is believed to be accurate and reliable. However, Cobham Wireless assumes no responsibility for its use. In no event shall Cobham Wireless be liable for any damage resulting from loss of data, loss of use, or loss of profits and Cobham Wireless further disclaims any and all liability for indirect, incidental, special, consequential or other similes damages. This disclaimer of liability applies to all products, publications and services during and after the warranty period.

Safety Instructions and Warnings

Throughout this manual, important safety warnings and admonishments are included to warn of possible hazards to persons or equipment. A safety warning identifies a possible hazard and then describes what may happen if the hazard is not avoided. The safety warnings – in the form of Dangers, Warnings and Cautions must be followed at all times. These warnings are flagged by the use of a warning icon, usually the triangular alert icon seen below. The exclamation point within the triangular alert icon is intended to warn the operator or service personnel of operation and maintenance from factors relating to the product and its operating environment, which could pose a safety hazard.

Guarantees

All antennas must be installed with lightning protection. Damage to power modules, as a result of lightning are not covered by the warranty.

Switching on AC or DC power prior to the connection of antenna cables is regarded as faulty installation procedure and therefore not covered by the Cobham Wireless warranty.

Repeater enclosures should be closed using the two screws. The screws must be fully tightened. Failure to do so may affect the IP65 compliancy and therefore any warranty.

Unauthorized Changes to Equipment

Changes or Modifications not expressly approved by the manufacturer responsible for compliance could void the user's authority to operate the equipment

Exclusive Remedies

The remedies provided herein are the Buyer's sole and exclusive remedies. Cobham Wireless shall not be viable for any direct, incidental, or consequential damages, whether based on contract, tort, or any legal theory.

General Safety Warnings Concerning Use of System

Always observe standard safety precautions during installation, operation and maintenance of this product.



Caution labels!

Throughout this manual, there are "Caution" warnings. "Caution" calls attention to a procedure or practice, which, if ignored, may result in injury or damage to the system, system component or even the user. Do not perform any procedure preceded by a "Caution" until the described conditions are fully understood and met.



Danger: Electrical Shock

This equipment can either be installed indoors or outdoors. When installed outdoors - wet conditions increase the potential for receiving an electric shock when installing or using electrically powered equipment. To prevent electrical shock when installing or modifying the system power wiring, disconnect the wiring at the power source before working with un insulated wires or terminals.



Caution: Safety to personnel

Before installing or replacing any of the equipment, the entire manual should be read and understood.

The user needs to supply the appropriate AC or DC power to the booster. Incorrect power settings can damage the Booster and may cause injury to the user.

Please be aware that the equipment may, during certain conditions become very warm and can cause minor injuries if handled without any protection, such as gloves.



Caution: Safety to equipment

When installing, replacing or using this product, observe all safety precautions during handling and operation. Failure to comply with the following general safety precautions and with specific precautions described elsewhere in this manual violates the safety standards of the design, manufacture, and intended use of this product.

Cobham Wireless assumes no liability for the customer's failure to comply with these precautions. This entire manual should be read and understood before operating or maintaining the booster.



Warning: Restricted Access Location

Access to the unit installation location is restricted to SERVICE PERSONNEL who have been instructed on the restrictions and the required precautions to be taken.

Compliance with FCC

FCC Part 90

| |
|---|
| Part 90 Signal boosters THIS IS A 90.219 CLASS A DEVICE |
|---|

 **WARNING!!!** This is NOT a CONSUMER device. This device is designed for installation by FCC LICENCEES and QUALIFIED INSTALLERS. You must have an FCC LICENCE or express consent of an FCC Licensee to operate this device. (You MUST register Class B signal boosters (as defined in 47 CFR 90.219) online at www.fcc.gov/signal-boosters/registration.)

Unauthorized use may result in significant forfeiture penalties, including penalties in excess of \$100,000 for each continuing violation.

This repeater must be operated as a Part 90 Class A repeater. The installation procedure must result in the signal booster complying with FCC requirements 90.219(d). In order to meet FCC requirements **90.219(d)**, it may be necessary for the installer to reduce the UL and/or DL output power for certain installations.

FCC Part 90 for 700/800MHz

FCC Part 90 is valid ONLY for SMR 700/800 high power Class A booster models supporting up to 10MHz bandwidth as follows:

- FCC Part 90 is valid ONLY for SMR 700 high power Class A booster models supporting the following (maximum) bandwidths: 758 - 775MHz, 788 – 805MHz
- FCC Part 90 is valid ONLY to SMR 800 high power Class A repeater models supporting the following (maximum) bandwidths: 806 - 817MHz, 851 – 862MHz

FCC Part 15

This device complies with part 15 of the FCC Rules. Operation is subject to the following two conditions:

1. This device may not cause harmful interference, and
2. This device must accept any interference received, including interference that may cause undesired operation.

This equipment has been tested and found to comply with the limits for a **Class A** digital device, pursuant to part 15 of the FCC Rules. These limits are designed to provide reasonable protection against harmful interference when the equipment is operated in a commercial environment. This equipment generates, uses, and can radiate radio frequency energy and, if not installed and used in accordance with the instruction manual, may cause harmful interference to radio communications. Operation of this equipment in a residential area is likely to cause harmful interference in which case the user will be required to correct the interference at their own expense.

FCC Part 20 for CMRS applications

FCC Part 20 is applied for 800MHz high power Class A Booster models running CMRS services under the following bands: 817 – 824MHz, 862 – 869MHz.

FCC RF Exposure Limits

This unit complies with FCC RF exposure limits for an uncontrolled environment. This equipment must be installed and operated with a minimum distance of 28cm between the radiator and any person's body.

Antenna Installation

Installation of an antenna must comply with the FCC RF exposure requirements. The antenna used for this transmitter must be mounted on outdoor or indoor permanent structures. The maximum antenna gain for indoor operation is 2.2 dBi and for the external antenna is 7dBi. Cable loss of at least 2dB is taken into account for all cases.

Antennas having a gain greater than these are strictly prohibited for use with this device. In indoor applications the antenna must be installed at a minimum separation distance of 28cm from all nearby persons.

Note the following:

In a DAS system, the loss due to cable insertion, splitter, etc., is assumed to be approximately 9 dB.

Gmax antenna gain (dBi) = EIRP – Pout + Insertion Loss = 38 – 40 + 9 = 7 dBi

EIRP = Pout – insertion Loss + Gmax antenna gain (dBi) = 40 – 9 + 7 = 38 dBm

ERP = 38 -2.15 = 35.85 dBm = 3.85 W < 5 W ERP

Compliance with IC

Under Industry Canada regulations, this radio transmitter may only operate using an antenna of a type and maximum (or lesser) gain approved for the transmitter by Industry Canada. To reduce potential radio interference to other users, the antenna type and its gain should be so chosen that the equivalent isotropically radiated power (e.i.r.p.) is not more than that necessary for successful communication.

The Manufacturer's rated output power of this equipment is for single carrier operation. For situations when multiple carrier signals are present, the rating would have to be reduced by 3.5 dB, especially where the output signal is re-radiated and can cause interference to adjacent band users. This power reduction is to be by means of input power or gain reduction and not by an attenuator at the output of the device.

This equipment complies with IC RSS-102 radiation exposure limits set forth for an uncontrolled environment. This equipment should be installed and operated with minimum distance 42 cm between the antenna and your body,

Conformément à la réglementation d'Industrie Canada, le présent émetteur radio peut fonctionner avec une antenne d'un type et d'un gain maximal (ou inférieur) approuvé pour l'émetteur par Industrie Canada. Dans le but de réduire les risques de brouillage radioélectrique à l'intention des autres utilisateurs, il faut choisir le type d'antenne et son gain de sorte que la puissance isotrope rayonnée équivalente (p.i.r.e.) ne dépasse pas l'intensité nécessaire à l'établissement d'une communication satisfaisante.

La puissance de sortie nominale indiquée par le fabricant pour cet appareil concerne son fonctionnement avec porteuse unique. Pour des appareils avec porteuses multiples, on doit réduire la valeur nominale de 3.5 dB, surtout si le signal de sortie est retransmis et qu'il peut causer du brouillage aux utilisateurs de bandes adjacentes. Une telle réduction doit porter sur la puissance d'entrée ou sur le gain, et ne doit pas se faire au moyen d'un atténuateur raccordé à la sortie du dispositif.

Cet appareil est conforme aux limitations de la norme IC RSS-102 concernant l'exposition aux radiations dans un environnement non contrôlé. Cet appareil doit être installé et utilisé avec une distance minimale de 42 cm entre l'antenne et le corps de l'utilisateur.

Table of Contents

| | | |
|----------|---|-----------|
| 1 | INTRODUCTION | 1 |
| 1.1 | Main Features | 1 |
| 1.2 | Booster Interfaces | 2 |
| 1.3 | Architecture | 3 |
| 1.4 | Smart-ALC Function | 4 |
| 1.5 | Power Feeder and Battery Charger | 4 |
| 2 | BOOSTER PRE-INSTALLATION REQUIREMENTS AND GUIDELINES | 5 |
| 2.1 | Donor Antenna Considerations | 5 |
| 2.1.1 | Required Antenna Information | 5 |
| 2.1.2 | Donor Antenna specifications | 5 |
| 2.1.3 | Installation Criteria | 5 |
| 2.2 | Service Antenna Considerations | 6 |
| 2.2.1 | Required Information | 6 |
| 2.2.2 | Enabling Monitoring of Service Antennas | 7 |
| 2.2.3 | Indoor Installations | 7 |
| 2.2.4 | Outdoor Installations | 8 |
| 2.3 | Required BTS Information | 10 |
| 2.4 | Selecting the Booster Location | 10 |
| 2.4.1 | Installation Location Criteria and Environment | 10 |
| 2.4.2 | Verifying the Link between the BTS and the Signal Booster | 11 |
| 2.5 | RF Cable Installation Guidelines | 11 |
| 3 | BOOSTER MOUNTING AND INSTALLATION | 12 |
| 3.1 | Booster Installation Overview | 12 |
| 3.2 | Unpacking and Package Contents | 13 |
| 3.3 | Mounting the System | 14 |
| 3.3.1 | Rack Mount Installation | 14 |
| 3.3.2 | Wallmount Installation | 15 |
| 3.4 | Connections | 21 |
| 3.4.1 | Booster Grounding | 21 |
| 3.4.2 | Antenna Connections | 22 |
| 3.4.3 | Booster Dry-Contact Alarm Connections | 23 |
| 3.4.4 | Connecting Power and Power-Up | 25 |
| 3.4.5 | Power Connection to UPS | 25 |
| 3.4.6 | Power Connection to Battery Charger | 26 |
| 3.4.7 | Power-on | 26 |
| 3.4.8 | Operation with and without Battery Charger | 26 |
| 4 | SETUP AND COMMISSIONING | 27 |
| 4.1 | Overview of the Commissioning Procedure | 27 |
| 4.2 | Opening a Session to the Booster and Navigating the GUI | 28 |
| 4.2.1 | Open a First Time Local Web Session to the Booster | 28 |
| 4.2.2 | Navigating the Web GUI Application | 29 |
| 4.3 | RF Parameters and Filter Configuration | 32 |
| 4.4 | Date and Time Settings | 36 |
| 4.5 | External Alarms Configuration | 37 |
| 4.6 | IP Address and SNMP Notifications | 38 |
| 4.6.1 | Configuring the IP Address | 39 |

4.6.2 SNMP Trap Configuration40

4.7 Changing Password.....41

5 ADMINISTRATIVE OPERATIONS42

5.1 User Management42

5.1.1 User Levels42

5.1.2 Viewing the List of Defined Users.....42

5.1.3 Adding Users.....43

5.1.4 Editing a User.....43

5.1.5 Deleting a User.....43

5.2 General Parameters44

5.2.1 Booster Level General Parameters44

5.2.2 Band Level General Parameters45

5.3 Band-Level Configuration Backup/Restore46

5.3.1 The Backup/Restore Tab.....46

5.3.2 Backup Band Configuration47

5.3.3 Restoring Band Configuration47

5.3.4 Uploading Band Configuration File48

5.3.5 Saving Configuration File to Computer48

5.4 Software Upgrade48

5.4.1 CMU Software Upgrade49

5.4.2 Embedded Software Upgrade50

6 MONITORING AND TROUBLESHOOTING53

6.1 Booster Panel LEDs53

6.2 Booster Panel Alarms Connector54

6.3 WEB GUI Alarms Screens.....55

6.3.1 700-800 Alarms Screen.....55

6.3.2 CMU Alarms Screen - Activated Alarms57

6.3.3 Alarms Log.....57

6.4 Faults and Summary of Activated Alarms58

6.5 Modifying Alarm Severities.....59

APPENDIX A – BOOSTER SPECIFICATIONS.....60

APPENDIX B - ORDERING INFORMATION61

1 INTRODUCTION

This manual describes the installation and setup procedures for Cobham Wireless SMR 700 800 high power, Class A digital, public safety signal boosters.

All booster models relevant to this manual operate in the same manner will be referred to as the 'booster', where any differences in the software configuration procedure or parameters will be addressed in the relevant section.

It features up to 24 DSP based, software-controlled, variable bandwidth filters that are user-programmable across the 700 and 800 MHz bands. All public safety technologies are supported.

For each filter, the user can specify the start and stop frequencies to reduce the installation time of the signal booster and enable a very wide range of filters selection. Every configuration parameter, including filter tuning and selection, can be controlled via web based management. The patented Cobham Wireless' digital RF filter enables simple initial setup for any channel plan and if necessary, allows some basic reconfiguration due to re-banding.

The SALC - Smart ALC algorithm will reduce the gain to protect the signal booster from oscillation. When the gain cannot be reduced anymore a shut-down mechanism will be triggered.

The signal booster protects against degradation of the system's sensitivity and coverage. This is implemented by the inbuilt AGC per-channel (filter) feature, which permits equalization of the channel levels for uniform coverage.

This product meets the rigid requirements as defined by the NFPA and International Fire Code developmental organizations. The amplifier is painted a Fire Life Safety Red, meets NEMA4 compliance for hose down, and provides all Alarming outputs as defined by NFPA 2010, Chapter 24 including system and antenna failures. The signal booster is a DC fed unit.

NOTE: Optionally, an external battery charger unit is available as well. The charger is connected to the AC and includes a circuit to charge external batteries with all the dry contact alarms as defined in the NFPA standard: AC failure, Charger failure and Low battery.

1.1 Main Features

- Class A signal booster for SMR and public safety networks
- Supports APCO 25 phase 1 and 2 for public safety networks
- NFPA 72-2010, Chapter 24 and IFC 510.1 Compliant
- Support of 700MHz D block for LTE network
- Patented DSP filtering™ technology:
 - Supports a total of 24 independent filters per system
 - User programmable filters
- NEMA4 enclosure
- SALC-Smart ALC mechanism to protect the digital signal booster from oscillation and shutdown the signal booster when required
- Web based management, SNMP traps

1.2 Booster Interfaces

All booster interfaces are located on the underside as shown below.



WARNING! The signal booster must always be installed vertically and top-down – with the connectors on the underside for protection (see 3.3.2.2). Horizontal installation on a bench for long time may cause damage to the signal booster due to over-heating.

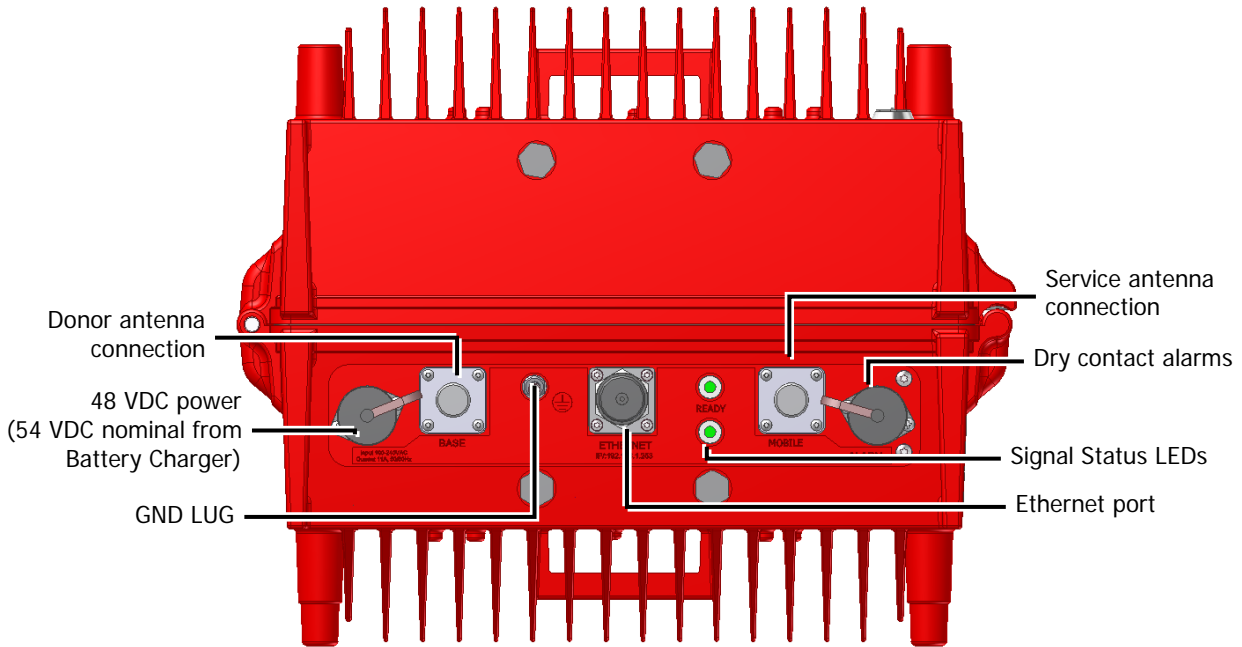

Figure 1-1. SMR 700 800 PS NFPA Front Panel

| Interface | Description |
|-----------|--|
| BASE | Donor antenna connections. See section 2.1. |
| MOBILE | Service antenna connections. See section 2.2. |
| 48 VDC | 48VDC input voltage. NOTE: If connected to Cobham Wireless Battery Charger, the input voltage will be 54 VDC nominal, as supplied by the Battery Charger, is accepted. |
| ALARMS | Two output relay alarms. See section 3.4.3. |
| GND LUG | Ground connection. See section 3.4.1 |
| LED'S | Status LEDs: <ul style="list-style-type: none"> • Upper LED - UL status for one or two bands. • Lower LED - DL status for one or two bands. Status: Green (OK), Orange (Warning), Red (Fail). See section 6.1 for detailed information. |

1.3 Architecture

To meet the National Fire Protection Association (NFPA) requirements, power to the Signal booster is provided via an uninterrupted power source. This can either be a UPS or (if a UPS is not available), an AC Feeder and Battery Charger (purchased separately).

The booster and its power source (UPS or Battery Charger), each provide dry-contact alarms towards the Fire Department Control Box. (The Battery Charger alarms are described in the dedicated manual. In case of UPS, refer to the manufacturer's instructions).

The booster supports the following alarms:

- Two dry-contact alarms
- One external alarm from the Battery Charger or UPS

Alarm connections to the Fire Department Control Box are used to monitor the status of the uninterrupted power source, Signal Booster and DAS system (antennas). The Alarm conditions are described in section 6.4 and section 3.4.3.3.

NOTE: As an alternative to the Fire Department Control Box connections, the booster and UPS or Charger dry contact alarms can be connected to an Automatic Dialer. The AD-2000 Automatic Voice/Pager Dialer System is recommended.

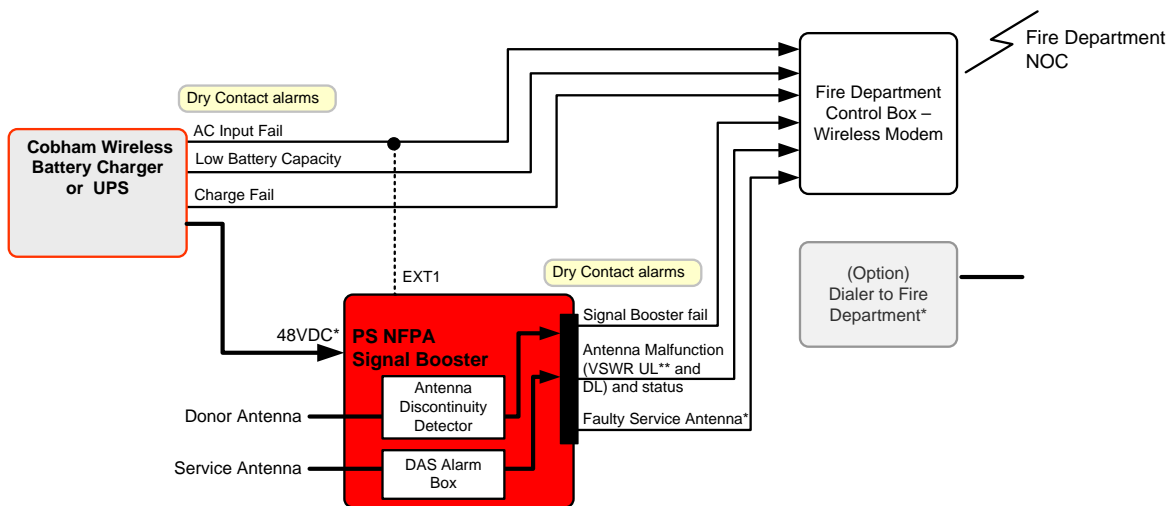

*Booster input voltage from Cobham Wireless Battery Charger = as supplied by Battery Charger (54 VDC nominal)
Booster input voltage from UPS = 48VDC

**Faulty Service Antenna or DAS Alarm Box will be indicated as VSWR UL ALARM and will be sent as Antenna Discontinuity OUT (dry-contact) alarm

Figure 1-2. SMR 700 800 PS NFPA Architecture

1.4 Smart-ALC Function

The Signal Booster's power amplifier includes power-monitoring circuits with Automatic Level Control (ALC) that prevents excessive output power while maintaining the power amplifier linearity

The Smart Automatic Level Control (Smart-ALC) is an innovative algorithm for automatic Signal Booster gain adjustment. Combined with advanced control algorithms, SALC is capable of learning the traffic load characteristics and adjusting the Signal Booster RF Gain to the desired value.

Note: To reset the Signal Booster to its highest set gain value, disconnect the Signal Booster power cable for several seconds and re-connect.

1.5 Power Feeder and Battery Charger

NOTE: The Power Feeder Battery Charger installation instructions are provided in a dedicated manual.

For installations where UPS is not available, the AC Feeder and Battery Charger unit can be purchased (see **Appendix B** for ordering information).

The charger is connected directly to the AC inlet and includes a circuit to charge external batteries. The charger also includes the following dry contact alarms (as defined in the NFPA standard): AC failure, Charger failure and Low battery.

NOTE: BATTERY LOW indication is when battery reaches 70% at current consumption of ~ C/25

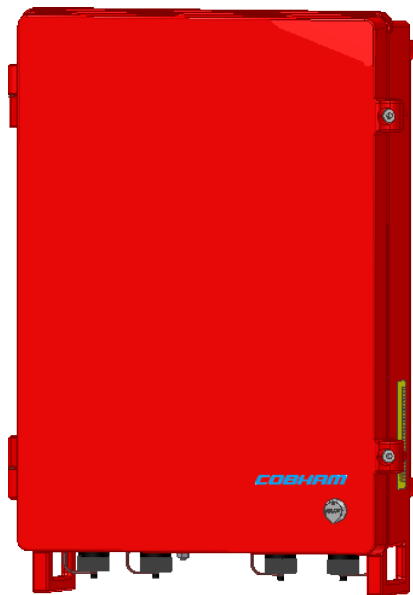

Figure 1-3. Battery Charger

2 BOOSTER PRE-INSTALLATION REQUIREMENTS AND GUIDELINES



WARNINGS!!

- The installer is held accountable for implementing the rules required for deployment.
- Good engineering practice must be used to avoid interference.
- Output power should be reduced to solve any IMD interference issues.

2.1 Donor Antenna Considerations

The Base (Donor) antenna is usually installed outdoors and is either a directional antenna such as a Yagi or a Panel antenna.

2.1.1 Required Antenna Information

You will require the following antenna information:

- Antenna type and characteristics
- Height
- Length and type of coaxial cable required for connecting the Donor antenna to the Signal Booster and the attenuation.

2.1.2 Donor Antenna specifications

- Yagi type or similar – 10 to 15 dBi gain, very sharp beam pointed to the BTS.
- Cable and jumper loss is at least 2dB.
- The required Base signals should be the dominant signals; at least 6 dB higher power than other signals.
- Example of antenna's typical specifications:

Gain: 8 dBd (=10.1 dBi)

VSWR: < 1:5:1

Impedance: 50 ohm

2.1.3 Installation Criteria

NOTE: Verify that the antennas meet requirements described in the previous sections..

Installation requirements:

- Select a location for the Donor antenna and verify that there is the signal strength is strong enough at that location.
- Install the Donor Antenna at the designated height.
- The antenna should point to the direction of the base station for maximum input power.
- Verify that the antenna is in the base stations line of sight (raise the antenna if necessary).
- Install the donor antenna at a higher level (i.e. floor) than the mobile antenna.
- Must be installed at a minimum distance of 1 meter from any personnel within the area.

- The Booster supports monitoring of DC Donor antennas. This requires a DC path through the transmission line (and lightning protector) to the donor antenna. If the donor antenna doesn't provide a DC return path, install a 1dB attenuator at the Donor antenna as illustrated in Figure 2-1.

NOTE: A 1dB attenuator is provided in the packing list. Use the same type of attenuator for the Donor antenna (if it does not provide a DC return path). If used on an antenna installed outdoors, be sure provide suitable weatherproofing over attenuator and connectors or fit inside building.

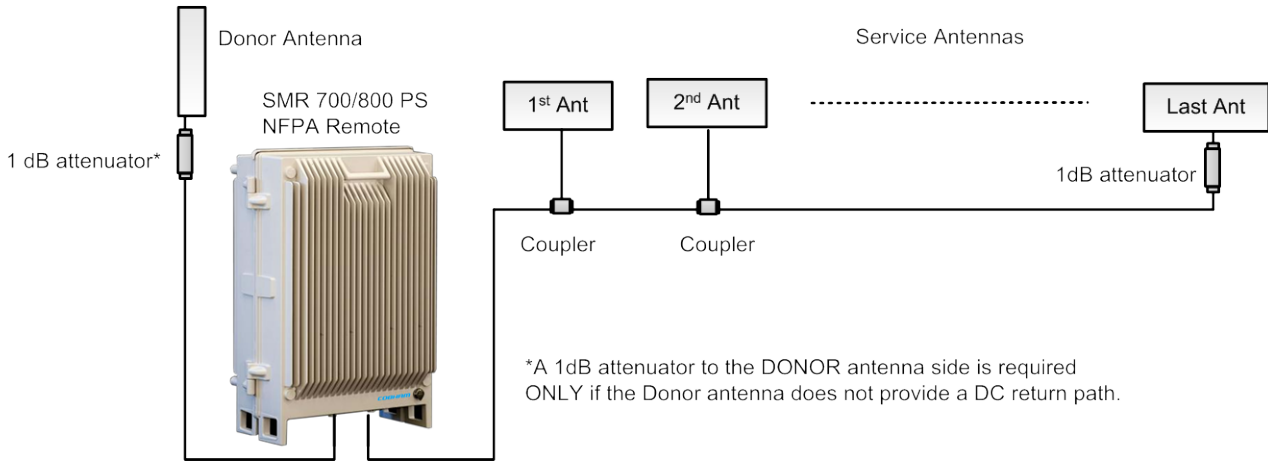

Figure 2-1. Antenna Connections

2.2 Service Antenna Considerations

The Service antenna type depends on whether the Signal Booster is installed indoors or outdoors.

2.2.1 Required Information

The following antenna requirements, specifications and site considerations should be met.

- Type of installation – indoor or outdoor
- Service area size
- Height at which antenna(s) is/are installed
- Antenna type and characteristics
- Length and type of coaxial cable required for connecting the Service antenna to the Signal Booster and the attenuation.

2.2.2 Enabling Monitoring of Service Antennas

For both indoor and outdoor service antennas:

The Booster supports monitoring of DC Service antennas. This requires a DC path through the transmission line (and lightning protector) to the Service antennas. If the LAST Service antenna doesn't provide a DC return path, install a 1dB attenuator as illustrated in Figure 2-1.

NOTE: It is required to install a *single* 1dB attenuator on the last service antenna (or on *one* of the last service antennas if a splitter is used). If used on an antenna installed outdoors, be sure provide suitable weatherproofing over attenuator and connectors or fit inside building.

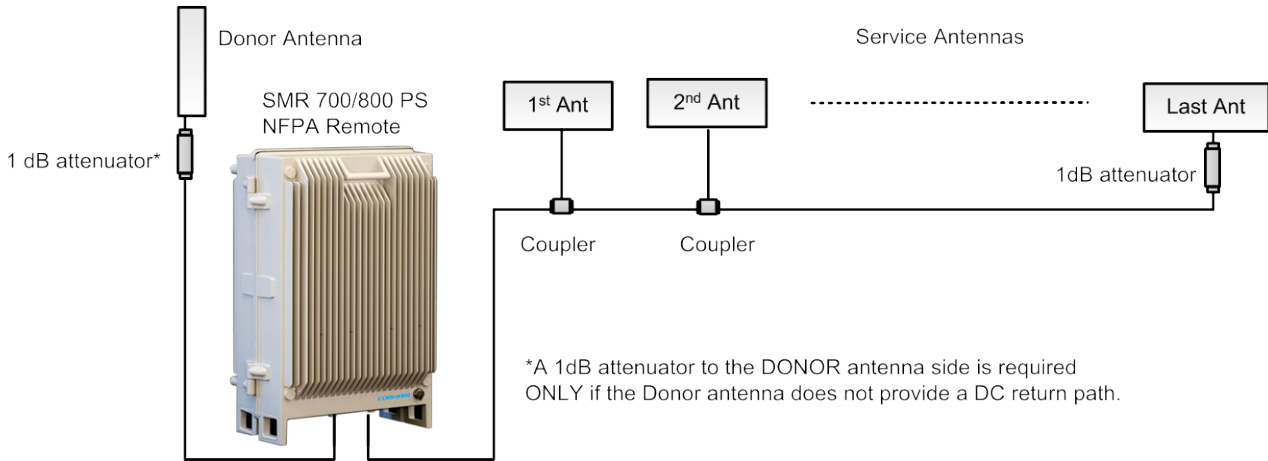

Figure 2-2. Antenna Connections

2.2.3 Indoor Installations

2.2.3.1 Recommended Antennas

The following describes the requirements for an omni-directional mobile used for indoor applications.

Specifications:

- One or a combination of the following antennas can be used: Ceiling Mount Patch antenna, Wall Mount Patch antenna, Corner Reflector.
- Omni directional antenna with a 0 to 2 dBi typical gain, or wide beam with up to 10 dBi gain.
- Example of omni-directional antenna specifications:
 - Gain: 0 to 2 dBi
 - VSWR: < 2:1
 - Impedance: 50 ohm
- Choose an antenna with high side lobe attenuation that allows maximum isolation from the service/mobile antenna.
- A minimum of 5 such antennas must be connected to the Signal Booster with cables and splitters.
- The maximum EIRP from each antenna shall not exceed 3W.

2.2.3.2 Installation Criteria

Installation requirements:

- An indoor antenna should be installed at a convenient location. It should be free of metallic obstruction.
- Install the Service Antenna at the designated height and tune it roughly toward the Service coverage area.
- Installation of this antenna must provide a minimum separation distance of 28cm for FCC and 42cm for IC, from any personnel within the area.

Note: If the power is divided into more than 5 antennas that have a large coverage area than the separation distance can be less than the given distance.

- Cable and jumper loss is at least 2dB.

2.2.4 Outdoor Installations

For applications in which the Mobile antenna is installed outdoors, the antenna type is chosen according to the available infrastructure (single-pole or horizontal installation). In addition, isolation between the donor and service antennas must be taken into account when selecting the location of the antennas.

2.2.4.1 Recommended Antennas

The antenna type depends on the installation:

- For vertical *Single Pole* installations a **high side lobe suppression antenna** is required.
- For horizontal installations either on two separate poles or on two sides of one building a **high front to back ratio antenna** is required.

Specifications:

- Maximum antenna gain for outdoor operation 9dBi.
- Cable and jumper loss is at least 2dB.
- [Gain Antenna – Cable loss] should not exceed 7dB

Installation requirements:

- Installation of this antenna must provide a minimum separation distance of 62cm for FCC and 91cm for IC, from any personnel within the area.

NOTE: The Single Pole and Horizontal Installations are described in section 2.2.4.2 and 2.2.4.3.

2.2.4.2 Vertical Separation Configuration

The Vertical Separation configuration is recommended in cases where the BTS is relatively far and the service coverage area is relatively small.

In Vertical Separation configuration, the Donor antenna can be installed either above or below the Service antenna on a COMMON tower. It is required to set the distance between them to achieve maximum isolation.

The figures below illustrate the installations.



Figure 2-3. Service above Donor Antenna



Figure 2-4. Donor above Service Antenna

2.2.4.3 Horizontal Separation Configuration

In the Horizontal Separation configuration, the Donor and Service antennas are installed on two separate towers at approximately the same height. The towers can be either on the same side of the building or on different sides of the building as shown below.

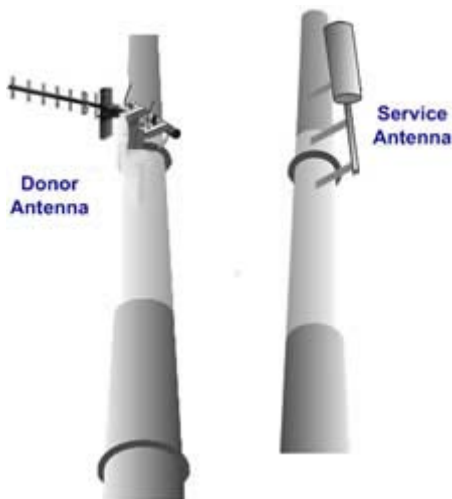

Figure 2-5. Donor and Service Antennas Installed on Separate Towers



Figure 2-6. Service and Donor Antennas Installed on Opposite Sides of the Building

2.2.4.4 Verifying Isolation between Donor and Service Antennas

Note the following:

- The isolation between the Donor and Service antennas is critical especially for high gain, outdoor applications.
- For proper operation of the Signal Booster, it is recommended that the isolation between the Donor and Service antennas be at least 15dB higher than the Signal Boosters set gain. (Lower isolation can lead to high in-band ripple, oscillations and low signal quality.)
- Ensure proper vertical or horizontal distance separation between Donor and Service antennas

To measure the isolation, proceed as follows:

1. Inject a known signal from a signal generator into one antenna (preferably the Donor antenna).
2. Measure the coupled output from the Service antenna, using the Spectrum analyzer and LNA if applicable.
3. Perform this procedure across the frequency range of both the Uplink and Downlink bands.
4. Register the lower result for system operation.

2.3 Required BTS Information

Required BTS Information

- BTS channels
- BTS output power per channel
- BTS antenna gain
- BTS antenna height and distance from antenna site

2.4 Selecting the Booster Location

When selecting a location, verify the requirements described in this section are met.

2.4.1 Installation Location Criteria and Environment

Location criteria

- **Application type** – indoor or outdoor
- **Distance from antenna site and BTS antenna height.**
It is recommended that the installation location be as close as possible to the antenna site in order to maintain the cable loss to a minimum.
- **General surroundings and accessibility of location**
- **Mounting surface** - Use a suitable mounting surface, such as a flat back rigid wall.
- **Plan mount** – according to overall dimensions of the unit enclosure.
- **Plan connection cable clearances** - the connections located on the underside of the unit will need at least 300mm vertical clearance below the unit to enable the connections to be made. The minimum bend radius for RF cables must not be less than the recommendations made by the cable manufacturer. Plan the cable runs and ensure adequate space is available.
- **Allow for door opening** - ensure that there is sufficient space at the front of the unit to allow the door to be fully opened and for maintenance engineers to get access to the unit with test equipment such as a spectrum analyzer. Allow an additional 500mm of space in front of the unit when the door is fully open.

- **Allow for heat dispersion** - Mount the repeater so that heat can be dispersed from it.

The repeater wall mounting kit ensures an optimum airflow between the wall and the repeater.) Do not block this air channel as it will cause the MTBF of the repeater to drop dramatically, or even in the worst case cause the repeater to fail completely.

If possible, use a wall in the shade to minimize the overall sun loading. If sufficient shielding cannot be obtained, an additional sun shield should be mounted.



Figure 2-7: Example of a sun shield

2.4.2 Verifying the Link between the BTS and the Signal Booster

This test checks the signal strength from the BTS antenna to the Signal Booster.

Proceed as follows:

1. Using a Spectrum analyzer, measure the received signal from BTS at the Donor antenna port near the Signal Booster.
2. Adjust the Donor antenna direction to receive the maximum signal strength.
3. Compare the received signal strength with the calculated signal strength from the design phase.

In case of discrepancy, check for one of the following:

- Antenna out of direction
 - Antenna tuned to side lobe instead of main lobe
 - Antenna connector or antenna cable faulty
 - Line-of-sight problem (obstruction), etc.
4. Register the signal strength of the downlink channel for the system operation phase.

2.5 RF Cable Installation Guidelines

- For all coaxial connections to/from the Signal Booster - high performance, flexible, low loss 50 ohm coaxial communications cable.
- All cables shall be weather-resistant type.
- If the coaxial cables are NOT weather-resistant type: wrap the exterior coaxial cables with insulation and holding tape (Type 3M Rubber splicing tape) for environmental protection and to ensure longer lifetime.
- Cable length - determined by the Signal Booster installation plan. When calculating the cable length, take into account excess cable slack so as not to limit the insertion paths.

3 BOOSTER MOUNTING AND INSTALLATION

This chapter describes the booster installation.

Note the following:

- It is assumed the location of the booster has been selected according to the criteria listed in section 2.4.
- If included in the installation, the Battery Charger is installed adjacent to the Booster. Refer to the Battery Charger manual for instructions on installing the Battery Charger.



WARNINGS!!!

- Follow all local safety regulations when installing the Signal Booster.
- Only qualified personnel are authorized to install and maintain the Signal Booster.
- Follow Electro-Static Discharge (ESD) precautions.

3.1 Booster Installation Overview

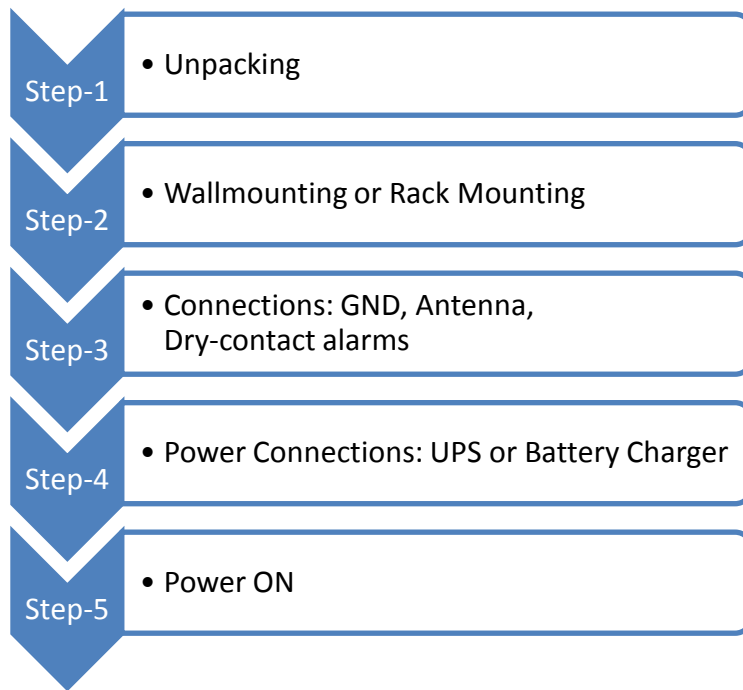







Figure 3-1 Physical Installation Workflow

3.2 Unpacking and Package Contents

Upon receiving the booster package, perform the following:

1. Examine the shipping container for damage before unpacking the unit.
2. Perform a visual inspection to reveal any physical damage to the equipment.
3. Verify that all of the items listed in the packing list are included. Otherwise contact your Cobham Wireless service representative.

Booster Package Contents

| Item | Description | |
|--|---|---|
| X1 CD containing User's Manual | Includes User Manual for the product. |  |
| Fixed N-type attenuator (M-F) 1dB 1W DC-6GHz | To be connected to the last service antenna. | |
| X2 Mounting Brackets | Used for wall-mount and rack-mount (different positions of brackets) |  |
| X1 Ethernet cross-cable | 3M RJ45-RJ45 Used for initial setup |  |
| 1 x Alarms cable | Circular 8 Pin (P/N 30WEC70500) |  |
| X1 DC Power Cable | Cable to DC power supply 40WVC70900 |  |
| Bolts and accessories for bracket assembly | X4 BOLTS M8 X4 FLAT WASHERs M8 X4 SPRING WASHERS M8 | |
| Bolts and accessories for wallmount | X4 BOLT ANCHOR JUMBO 3/8 ZINC PLATED X4 FLAT WASHERs # 3/8 X4 SPRING WASHERS # 3/8 NUTGND HEX #3/8 | |

3.3 Mounting the System



WARNING!! The signal booster must always be installed vertically with the connectors on the underside for protection (see 3.3.2.2). Horizontal installation on a bench for long time may cause damage to the signal booster due to over-heating.

Note the following:

- The mounting procedure is identical for both indoor and outdoor installations.
- The weight of the *Booster* requires that *two people* mount the unit on the wall.
- Washers are *not* supplied with the unit to be mounted.
- In addition to the bracket assembly, it is recommended to use *additional fixings* – an example is given in section 3.3.2.5.

3.3.1 Rack Mount Installation

The supplied brackets are used to mount the repeater either on a wall or in a 19" rack. The same brackets are used for both medium and high-power repeaters.



IMPORTANT!!

- The weight of the unit requires that two people mount the unit.
- The signal booster must always be installed vertically with the connectors on the underside for protection. *Horizontal installation on a bench for long time may cause damage to the signal booster due to over-heating.*

To mount the unit in a rack

1. Use the x4 (provided) **M8 Fixing Bolts** and **X4 M8 Spring Washers** and **x4 M8 Flat Washers** to assemble the brackets as illustrated in the adjacent figure.

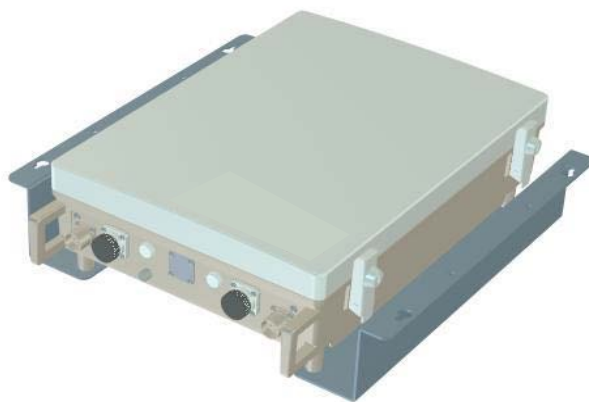

Figure 3-2: Rack-mount bracket position

2. Mount the unit *vertically* in the rack, while adhering to standard rack mounting procedures, and secure.

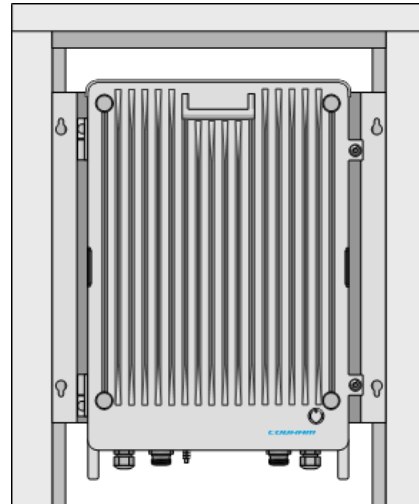



Figure 3-3: Rack-mount unit position

3.3.2 Wallmount Installation



IMPORTANT!!

- The unit mounting procedure is for concrete or brick walls only. *Verify the suitability of the wall on which the unit is to be fitted.*
- The weight of the unit requires that two people mount the unit on the wall.
- The signal booster must always be installed vertically with the connectors on the underside for protection. *Horizontal installation on a bench for long time may cause damage to the signal booster due to over-heating.*

3.3.2.1 Wallmount Bracket Assembly

NOTE: In addition to the mounting brackets, it is recommended to use additional fixings as described in section 3.3.2.5.

Assemble the brackets to the unit using the supplied **M8 Fixing Bolts** and **X4 M8 Spring Washers** and **x4 M8 Flat Washers** to assemble the brackets as shown in the following figure.

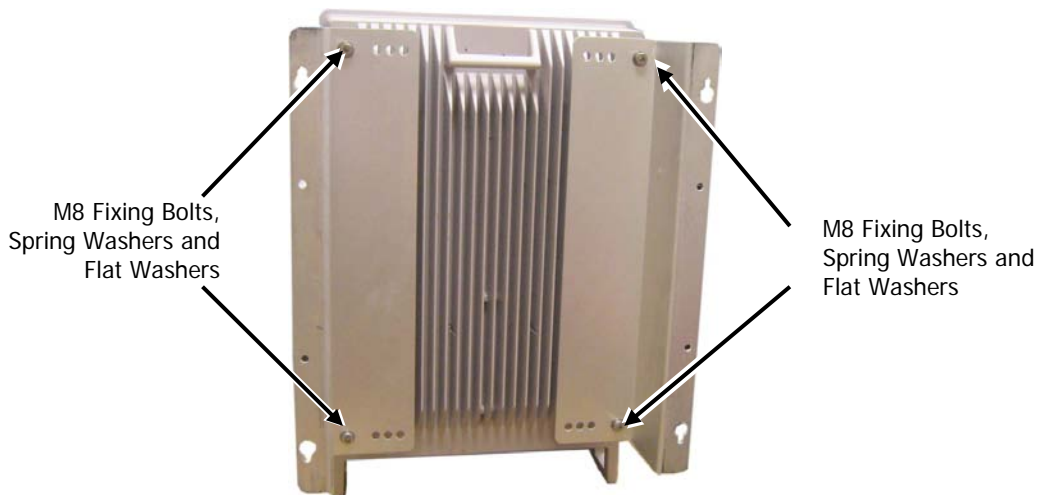



Figure 3-4. Bracket Assembly for Wall-mount

3.3.2.2 Wall Marking and Drilling – General Instructions

| | |
|---|---|
|  | <p>WARNINGS!!</p> <ul style="list-style-type: none"> • Due to the weight of the unit, it is NOT recommended to fix to a hollow wall. • Always check that there are no pipes or cables hidden in the wall beneath the area to be drilled. Various pipe and cable detectors are available for this type of inspection. |
|---|---|

Note the following:

- The Repeater wall mount brackets assembly should be fixed to a solid wall (these include brickwork, block work, and concrete).
- To provide secure fixing to a solid wall, the most common method is drilling and plugging. The size of fixing is dependent on the item to be fixed and the nature of the wall, The Repeater should be fixed with mild steel, M6 (50mm to 75mm) rawlbolts or similar.

The following items are provided in the kit:

- X4 BOLT ANCHOR JUMBO 3/8 ZINC PLATED
- X4 FLAT WASHERs # 3/8
- X4 SPRING WASHERS # 3/8
- NUTGND HEX #3/8

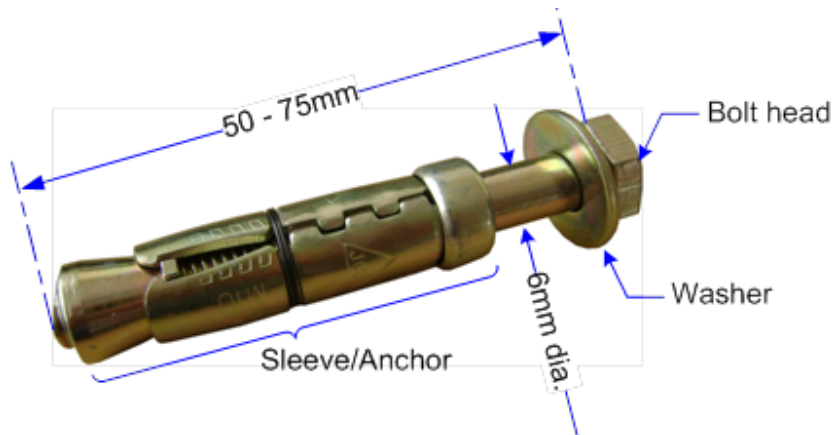

Figure 3-5: M6 Rawlbolt – recommended for wallmount.

- Care must be taken to ensure the alignment of the four fixings. A spirit level or plumb line should be used to ensure horizontal/vertical alignment.

3.3.2.3 Wall Marking and Drilling – Procedure

To mark and drill the wall

1. Mark out the fixing centers of the unit on the chosen wall. Refer to the dimensions are shown below.

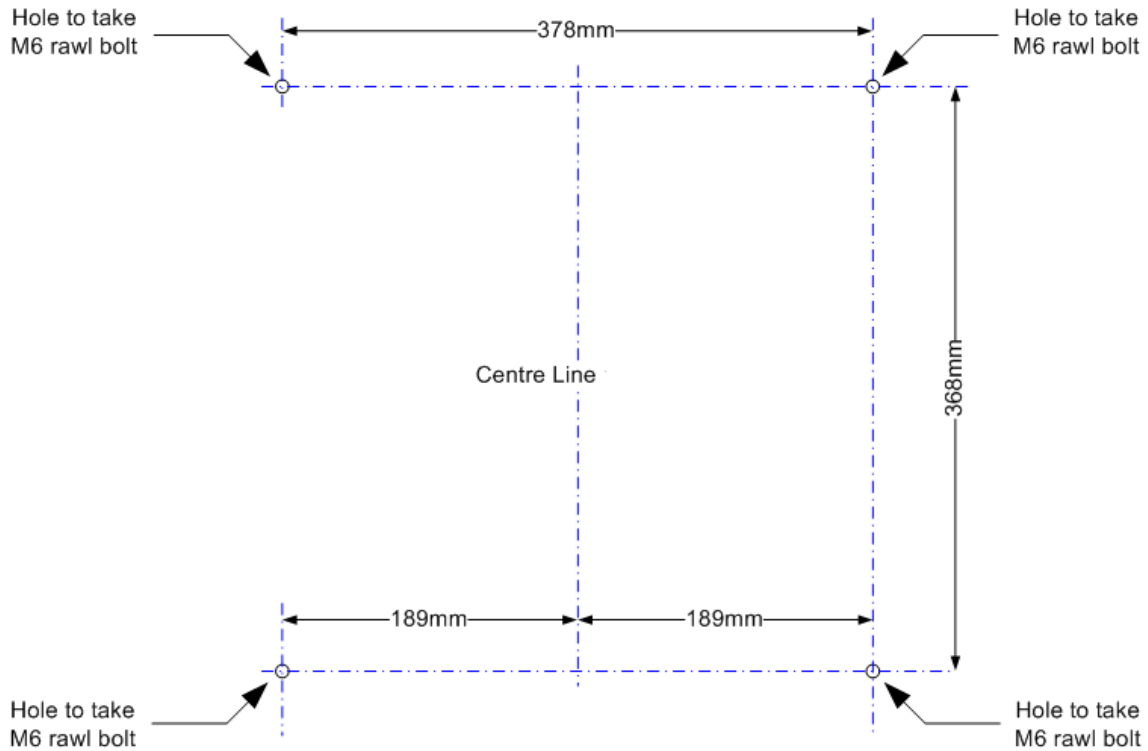

Figure 3-6: Fixing Centers

2. Mark and drill the wall with the correct size masonry bit as specified by the fixing manufacturer.

NOTE: It is good practice to wear goggles to protect your eyes from flying debris when using power tools.

3. Hold the drill bit against the mark and begin drilling slowly so that the bit does not wander from the position. The wall should be drilled to a depth which is sufficient to accommodate the full length of the fixing.
4. Insert the fixings so that the top of the sleeve/anchor section is level with the wall surface.
5. Gently tighten the bolt by hand so that the anchor section of the fixing expands and grips the inside of the hole.

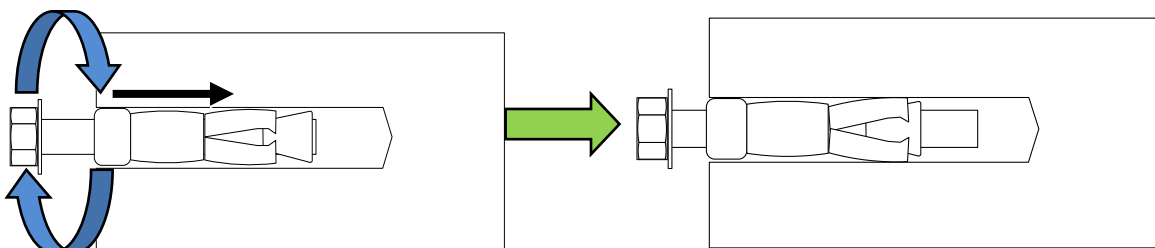

Figure 3-7: Inserting Fixing and Tightening.

- As the bolt pulls its way in, the sides of the anchor section are forced outwards, gripping the surrounding surface.

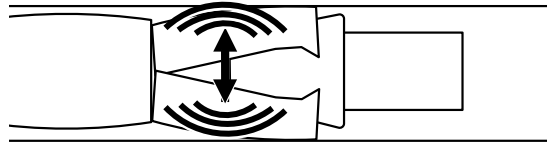

Figure 3-8: Anchor Sides Pushed Outwards.

- Once all four fixings are in place, carefully withdraw the four bolts.

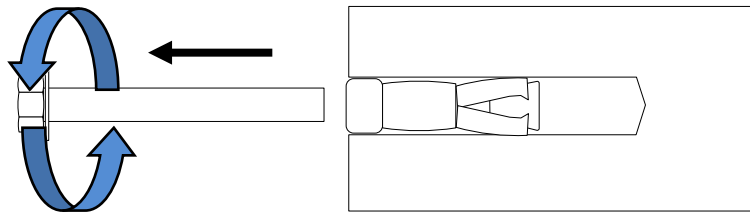



Figure 3-9: Withdraw Bolts.

3.3.2.4 Mounting the Unit

 **CAUTION!!** It is recommended that two people lift the unit.

To mount the Unit

- Align the unit with the four fixings.

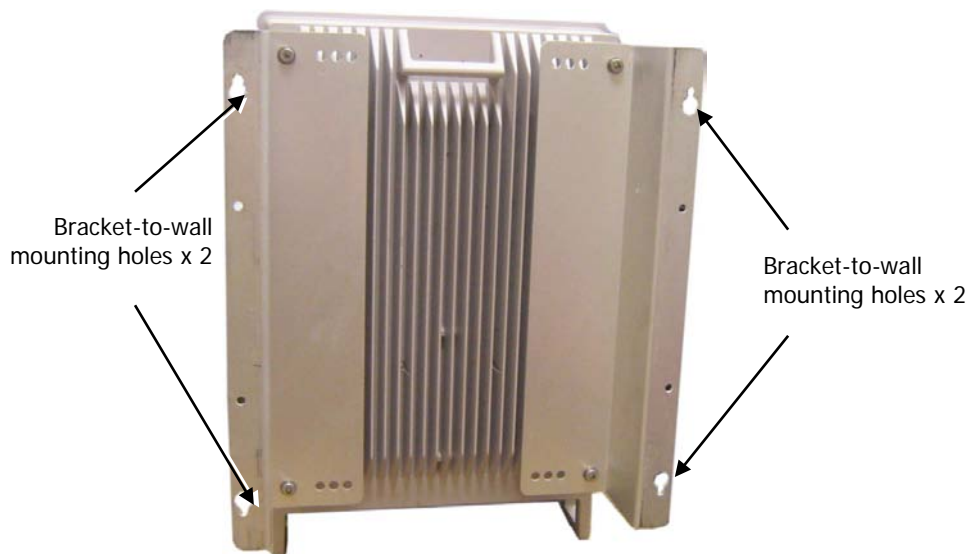

Figure 3-10. Mounting on wall

- Once unit is held in the chosen position, carefully insert the fixing bolts through the mounting lugs of the unit and into the sleeve/anchor sections of the fixing in the wall and tighten the bolts.

 **WARNING!** *The unit needs to be mounted tightly to eliminate vibration.*

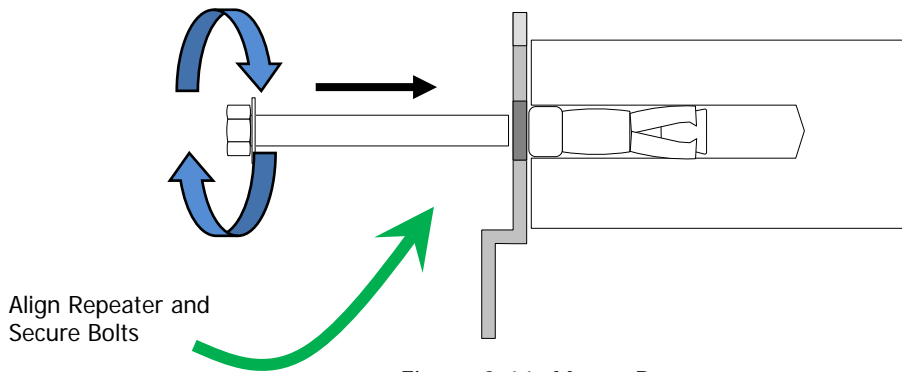



Figure 3-11: Mount Repeater

3.3.2.5 Recommended Additional Fixing

 **SUGGESTED PRECAUTIONARY MEASURE!!**

- Brackets are provided to securely mount the unit on the wall; however, as an *additional* precautionary measure, it is recommended to further secure the unit to the wall (in addition to the bracket).
- This can be done using any appropriate method.
- It is the installer's responsibility to ensure the unit is installed in a secure manner.

The following figures provide *examples* of additional fixings. In the examples, support is provided in the form of a CABLE HARNESS LOOP that is looped around the unit handle and secured to the wall or part of the building support structure.

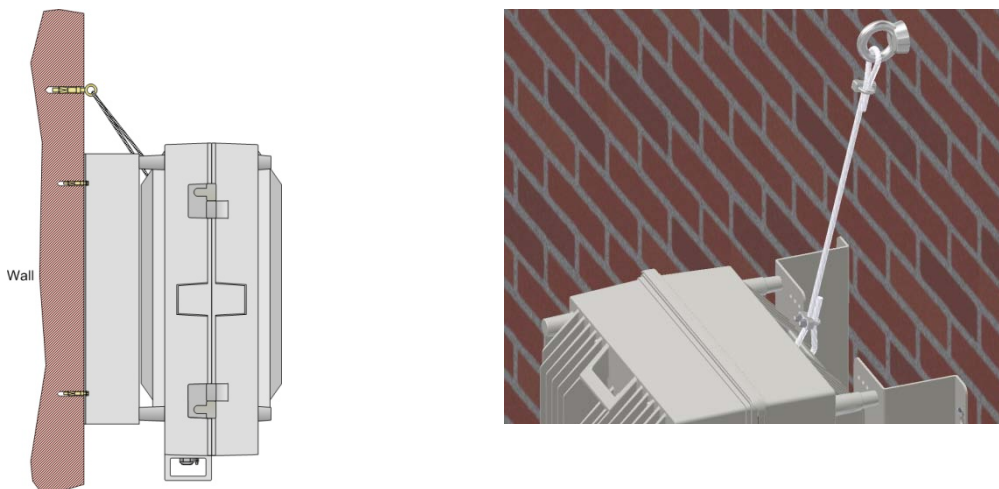



Figure 3-12: Example 1 of Additional Fixing to Wall

Another example is of a unit installed on a stadium gantry. Again, the support can be in the form of a cable harness loop, using the handle of the unit and part of the gantry structure.

 **ATTENTION!!** Any other *secure* method can be used.

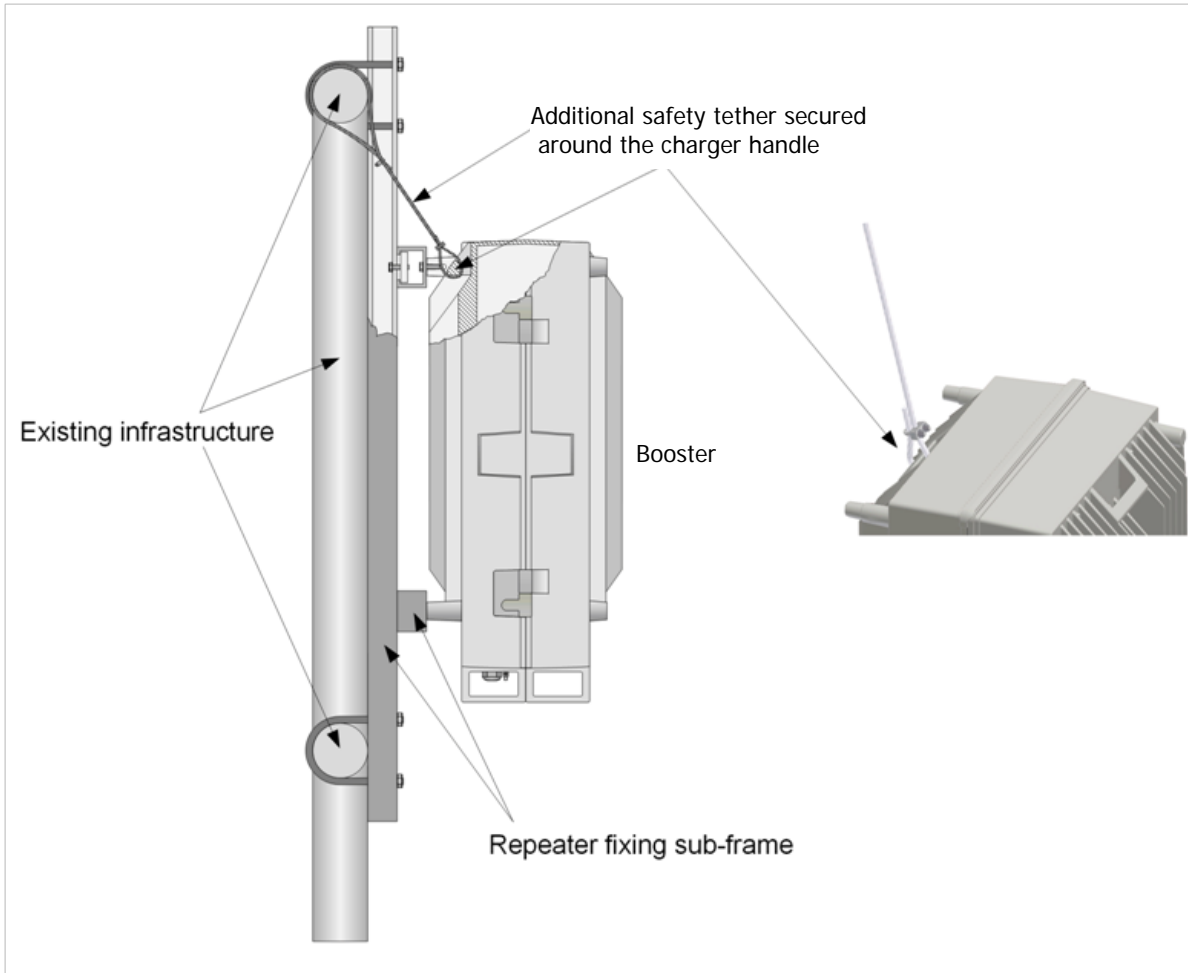



Figure 3-13: Example 2 of Additional Fixing to Gantry

3.4 Connections

This section describes the Booster connections:

- Grounding
- Antenna connections
- Dry-contact connections

3.4.1 Booster Grounding



CAUTION!! Ground must be connected **FIRST** and disconnected **LAST**.

Requirements for grounding wires

- Protective grounding conductor - should be aluminum with cross-section 10AWG.
- Lug of the protective grounding conductor - should be aluminum
- Washers and screw - should be high Cr stainless steel, or 12% Cr stainless steel, or Cr on, Ni on steel, tin on steel

 **WARNING!!** Ground the Signal Booster with the booster's grounding bolt. Do not use the grounding bolt to connect external devices.

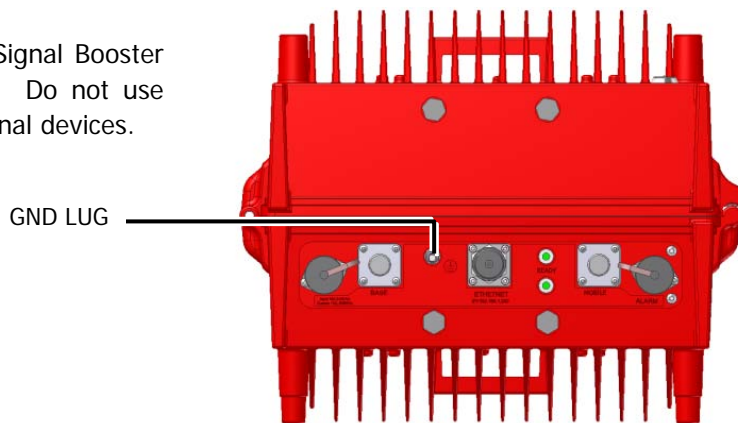

Figure 3-14 GND Lug

3.4.2 Antenna Connections



CAUTION!!

- Do not connect the antenna cables to the Signal Booster before verifying the installation parameters - specifically the isolation between the antennas.
- DO NOT POWER-ON the Signal Booster without either the antennas being connected or the antenna connections terminated with dummy loads.

To connect the antennas

- Connect the Donor and Service antennas.
- Verify all RF connectors are tightened and the cables and antennas are secured.

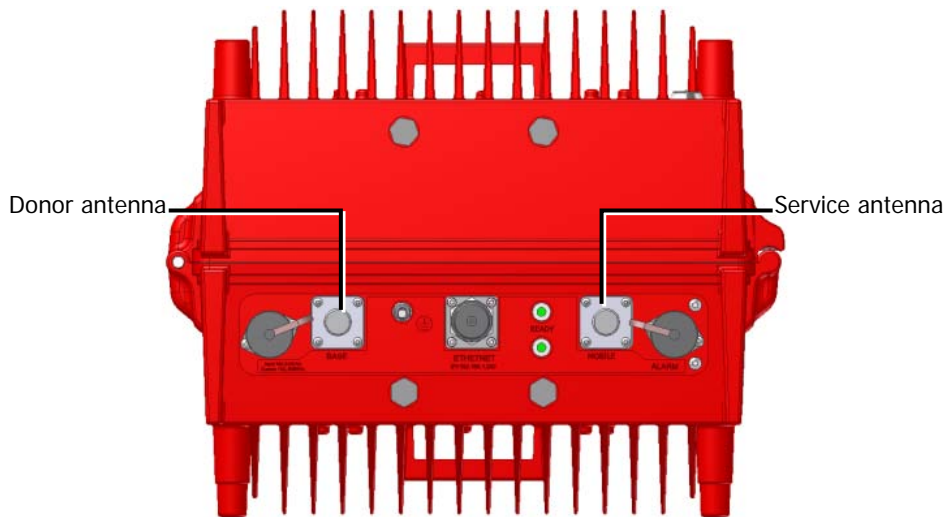

Figure 3-15 Booster GND Lug

3.4.3 Booster Dry-Contact Alarm Connections

This section describes the dry-contact alarm connections for the *booster*.

The booster and its power source (UPS or Battery Charger), each provide dry-contact alarms towards the Fire Department Control Box. (In installations with UPS, refer to your UPS manual for instructions on dry-contact alarm connections to the Fire Department Control box).

The booster supports the following alarms:

- Two dry-contact alarms
- One external alarm from the Battery Charger or UPS

NOTE: These can be connected any time, before or after the system is powered-on.

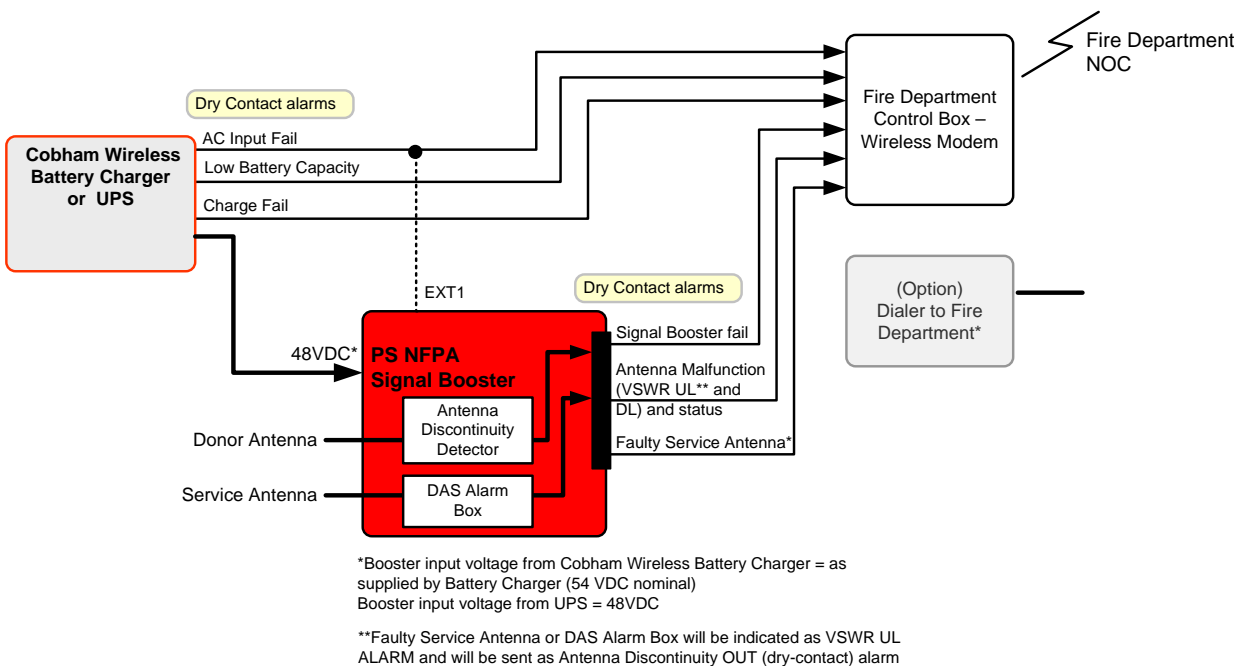

Figure 3-16. Booster with Charger Architecture

3.4.3.1 Alarm Dry Contact Output Restrictions

- Maximum switching voltage: 220 VDC, 125 VAC
- Maximum switching current: 2A

3.4.3.2 External Alarm Input Restrictions

- Maximum repetitive reverse voltage: 28 V
- Impedance load: 470 Ohm

"0" - 0V

"1" - 3.8V - 28V

3.4.3.3 Booster Alarm Connector Pinout

The Booster supports x2 dry-contact alarms connected to the Fire Department Control Box and one optional external alarm in that can be connected to the dry-contact alarms of the UPS or Battery Charger in order to provide SNMP notifications for that specific UPS or Battery Charger alarm.

Each alarm status is recognized by a separate wire-pair, where the colored wires are internally connected with a 4.7 K ohm resistor (serves as a pull up resistor to +5V. The following figure shows the Alarm connector pinout.

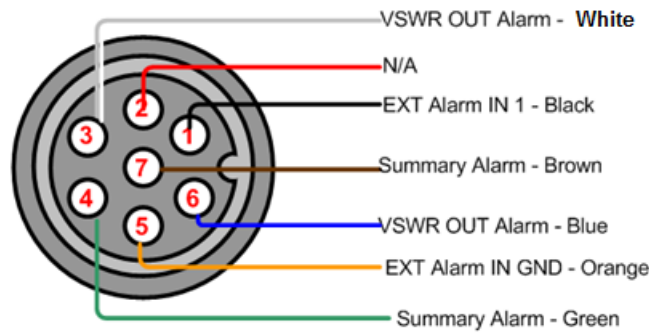

Figure 3-17. Booster Alarm Connector Pinout

| Pin No. | Signal Name | Wire Colour |
|---------|--|-------------|
| 1 | External Alarm #1 – optional. | Black |
| 2 | N/A | |
| 3 | Dry Contact VSWR OUT Alarm (Normally Closed)* | White |
| 4 | Dry Contact Summary Alarm (Normally Closed) | Green |
| 5 | GND for External Alarm | Orange |
| 6 | Dry Contact VSWR Alarm (Normally Closed)* | Blue |
| 7 | Dry Contact Summary Alarm (Normally Closed) | Brown |

Connect as follows:

- Connect the following to the **Fire Department Control Box**:
 - **VSWR Out Alarm** (pins 3 and 6);
 - **Summary Alarm** (pins 7 and 4)
- **Optional:** connect **EXT Alarm IN** (pins 1 and 5) to the relevant dry-contact alarm on the UPS or Booster. In addition, it is required to configure **EXT Alarm IN 1** as **Normal = High** in the management GUI according to section 4.5.

3.4.4 Connecting Power and Power-Up



CAUTION!!

- DO NOT POWER-ON the Signal Booster without either the antennas being connected or the antenna connections terminated with dummy loads.
- This equipment can either be installed indoors or outdoors. When installing OUTDOORS, wet conditions increase the potential for electric shock when installing or using electrically powered equipment. To prevent electrical shock when installing or modifying the system power wiring, disconnect the power source before working with uninsulated wires or terminals.

The Signal Booster operates from a 48VDC power source – either UPS or Cobham Wireless Battery Charger (ordered separately). The power connection differs according to the power source:

3.4.5 Power Connection to UPS

To connect the power to UPS

- Use supplied DC cable (P/N 40WVC70900)
- Verify the UPS is set up.
- Connect 48VDC from the UPS or AC to DC converter (depending on the installation) to the Booster Power Connector

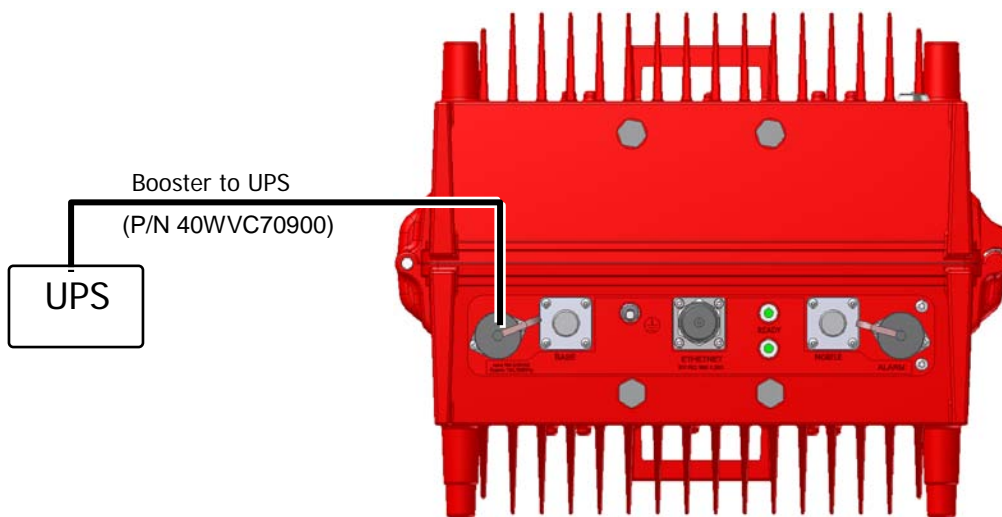

Figure 3-18 Battery Charger to Booster Power Connections

The cable pinout is as follows:

| Pinout | Color | Label |
|--------|-------|----------|
| 1 | N.C. | |
| 2 | RED | -48V RTN |
| 3 | N.C. | |
| 4 | BLACK | -48V |

3.4.6 Power Connection to Battery Charger

Note the following

- The instructions for Battery Charger to Booster power connections are provided in the Battery Charger User Manual.
- The cable used for interconnecting the units is provided with the Battery Charger accessories.
- Connect the Charger **DC Out** to the Booster **DC PWR**.

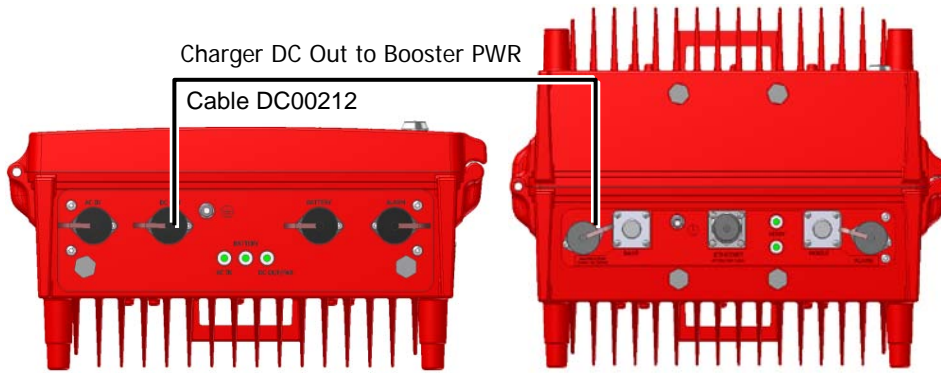

Figure 3-19 Battery Charger to Booster Power Connections

3.4.7 Power-on

To power-on

Simply switch the power ON at the power source.

3.4.8 Operation with and without Battery Charger

When the Booster is powered by the Battery Charger

| Charger AC Power | Charger BAT Power | Alarm Scenario | Dry contact alarm |
|------------------|-------------------|-----------------------------|---|
| OFF | ON | Charger NO AC Power | OPEN at Charger alarm connector pins 1,6 when Charger AC Power is OFF. Booster indication. |
| OFF | OFF | No booster or charger power | If the Booster is fed from a Charger and the Charger has NO AC and NO Battery power, the BDA can indicate NO PWR (NO AC /NO DC) alarm via it's dry contact pins 4,7. |

When Booster is not powered by the Battery Charger

| Booster AC Power | Charger BAT Power | Alarm Scenario | Dry contact alarm |
|------------------|-------------------|------------------|---|
| OFF | N/A | Booster NO Power | OPEN at Booster alarm connector at pins 4,7 when Booster has no Power |

4 SETUP AND COMMISSIONING

This section describes the setup procedures for the Booster.

NOTE: D-MBR 700/800 screens are used to illustrate the procedures in this chapter. Where relevant, differences in screen displays or parameter values for various models covered in this manual will be addressed.

4.1 Overview of the Commissioning Procedure

The Booster is designed for simple plug-and-play operation, only requiring the setup of a number of parameters via a local Web connection and verifying that the system is operating properly.

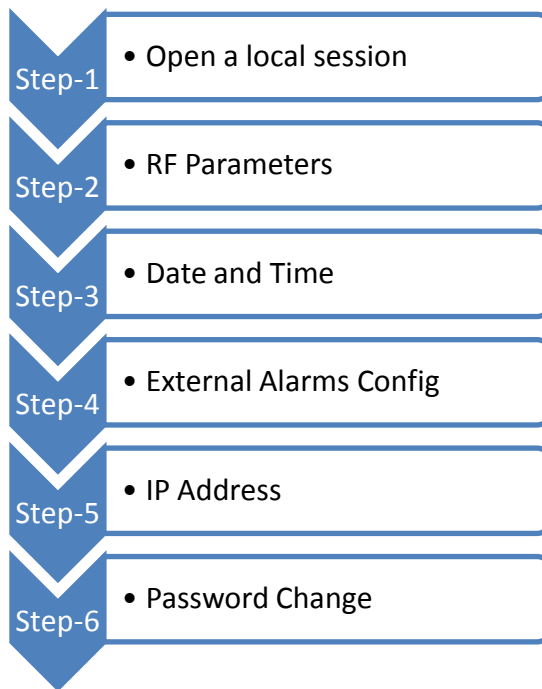

Figure 4-1 Commissioning Overview

4.2 Opening a Session to the Booster and Navigating the GUI

This section describes how to open a first time local session to the Booster and how to navigate the management Web GUI.

4.2.1 Open a First Time Local Web Session to the Booster

NOTE: To open a local session to the booster, the setup computer IP Address must be in the same subnet as that of the Booster. The booster factory set IP Address is **192.168.1.253**.

To open a local session to the booster:

1. Connect to the Boosters' front panel **Ethernet** port using the supplied Ethernet cable.

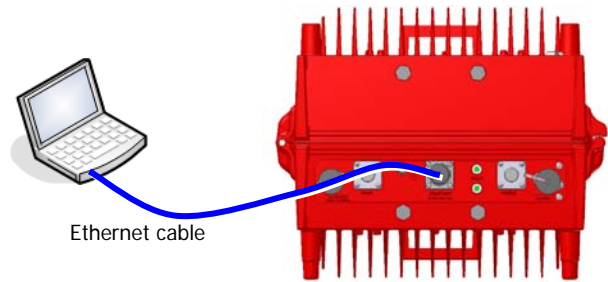

Figure 4-2. Local Setup Connection

2. Verify the setup computer's NETWORK PARAMETERS are in the same subnet as the Booster's factory assigned IP Address.

NOTE: Booster's factory assigned IP Address: **192.168.1.253**.

- On the computer, access the Internet Protocol Version 4 (TCP/IPv4) Properties dialog.
- Configure an IP address 192.168.1.x (e.g. 192.168.1.9)
- Set subnet mask to 255.255.255.0
- Click **OK** to save the definitions.

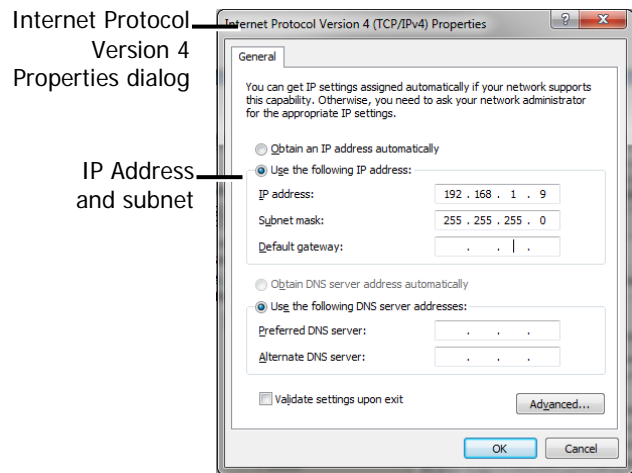

Figure 4-3. Computer's IP Address

3. Login to the Booster as follows:
 - Open a standard browser (e.g. Chrome, IE or Firefox).
 - In the address line, enter the IP address of the Booster. **192.168.1.253**



Figure 4-4. Factory Assigned IP Address

The Booster login dialog appears.

- Enter the authentication information:
Default User Name : **admin**
Default Password : **admin.**

NOTE: Both are case sensitive and must be entered with *lower* case letters.

- Click **Login**. The application main window appears.

NOTE: Quickly review the following section describing the application window and then proceed to configure the signal levels according to section 4.3.

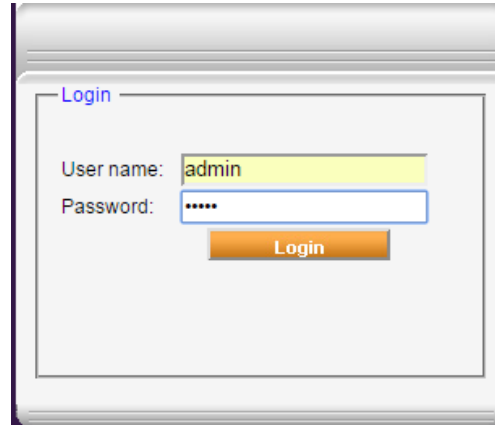

Figure 4-5. Login

4.2.2 Navigating the Web GUI Application

This section describes how to navigate the Web Management application. The GUI interface provides the following items:

- Operation options – always available in the header
- Menu selection left pane – provides three types of menu options
- Menu Tabs – sets of tabs corresponding to the selected left pane menu options
- Work area – corresponds to selected tab

Operation Buttons

700-800 Send Refresh CMU Reset Date&Time admin: Admin Help

Alarms Alarms Configuration **Control&Params** Band Info Backup/Restore SW Upgrade

System

RF Transmission Enable Temperature

Shut Down Mechanism

Max Composite DL Output Power [dBm] DL Output Threshold Delta [dB]

Max Composite UL Output Power [dBm] Meas. Composite DL Output Power [dBm]

| Filter | On | BW | Downlink | | | | | | Uplink | | | | | |
|--------|-------------------------------------|--------------|-------------------|-------------------|------------------|------------------|---------------------|-----------------------|-------------------|-------------------|------------------|------------------|---------------------|--|
| | | | Centre Freq [MHz] | Set Ch. Max Power | Set Ch. Max Gain | Meas. RSSI [dBm] | Meas. Ch. Gain [dB] | Meas. Ch. Power [dBm] | Centre Freq [MHz] | Set Ch. Max Power | Set Ch. Max Gain | Meas. RSSI [dBm] | Meas. Ch. Gain [dB] | |
| 1 | <input checked="" type="checkbox"/> | 50 KHz (N) | 760 | 30 | 95 | -120 | 95 | -25 | 790 | 17 | 95 | -120 | 95 | |
| 2 | <input checked="" type="checkbox"/> | 25 KHz (N) | 761 | 24 | 95 | -122 | 95 | -27 | 791 | 4 | 95 | -122 | 95 | |
| 3 | <input type="checkbox"/> | 25 KHz (N) | 762 | 24 | 95 | -128 | -128 | -128 | 792 | 4 | 95 | -128 | -128 | |
| 4 | <input checked="" type="checkbox"/> | 75 KHz (N) | 764 | 24 | 95 | -120 | 95 | -25 | 794 | 4 | 95 | -120 | 95 | |
| 5 | <input type="checkbox"/> | Unlisted | 760.8125 | 24 | 95 | -128 | -128 | -128 | 790.8125 | 4 | 95 | -128 | -128 | |
| 6 | <input type="checkbox"/> | Unlisted | 761.4375 | 30 | 95 | -128 | -128 | -128 | 791.4375 | 4 | 95 | -128 | -128 | |
| 7 | <input type="checkbox"/> | 6.25 KHz (N) | 762.0625 | 24 | 95 | -128 | -128 | -128 | 792.0625 | 4 | 95 | -128 | -128 | |
| 8 | <input type="checkbox"/> | 6.25 KHz (N) | 762.6875 | 24 | 95 | -128 | -128 | -128 | 792.6875 | 4 | 95 | -128 | -128 | |

UL 788 798 805

DL 758 768 775

Status: Setting succeeded

Figure 4-6. Main Window

4.2.2.1 Operation Items

The operation options are always displayed in the window header.

Selected menu item

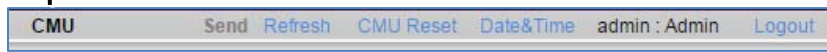

| Item | Description |
|-----------------|---|
| CMU/band/ Users | Shows the currently selected menu item. |
| Send | Uploads configuration changes to the Booster. |
| Refresh | Refreshes the current screen and displayed data |
| CMU Reset | Click to reset the Web Access application, in case of failure or display issues |
| Date and Time | Access Booster Date and Time settings. |
| User | Currently logged in authentication level and user (e.g. admin : Admin). |
| Logout | Click to logout current user. |

4.2.2.2 Left Pane Menu Options

The left pane contains three menu items, where clicking each item invokes dedication tabs and options:

- **CMU** – communication, general information, external alarm configuration and CMU SW upgrade options.
- **700/800** – RF configuration, monitoring, backup and restore and embedded SW upgrade options
- **Users** – user management tools, including *Password Change*.



Figure 4-7. Menu Item

4.2.2.3 700/800 Band Menu Tabs

This section describes the tabs available when **700-800** is selected in the left pane.



| Item | Band Specific Description |
|----------------------|---|
| Alarms | Common alarms pane for both bands. See section 6.3.1. |
| Alarms Configuration | Viewing and modifying default alarm levels (critical, major, minor), major). See section 6.5. |
| Control & Params | Band RF configuration options. See section 4.3. |
| Band Info | Access this tab to do the following (see section 5.2.2): <ul style="list-style-type: none"> • View band specific information, including supported filter width, SW build, and more. • For dual-band units, configure maximum number of filters available for each band (for a total of 24). |
| Backup and Restore | Used to backup and manage the configuration files. See section 5.3. |
| SW Upgrade | Embedded SW upgrade option. Section 5.4.2. |

4.2.2.4 CMU Pane and Tabs

This section describes the tabs available when the *CMU item* is selected in the left pane.



| Item | Description / Values |
|-----------------------------|---|
| CMU Alarms | Shows currently active alarms (see 6.3.2). |
| CMU Info | Access this tab to do the following (see section 5.2.2): <ul style="list-style-type: none"> • View Booster level information such as SW and HW versions and identification number. • Set minimum level of displayed alarms (see 5.2.1). |
| Communication Configuration | Used to set IP Address and SNMP parameters (see 4.6) |
| Alarms Log | Displays booster level log of past and current alarms (see 6.3.3). |
| External Alarms | Provides external alarm configuration options: High/Low, name, etc. (see 4.5) |
| CMU SW Upgrade | Used to perform CMU software upgrade (see 5.4.1) |
| Modem Direct Access | N/A |

4.3 RF Parameters and Filter Configuration

A total of 24 filters can be defined for each unit. For D-MBR 700 800 (a booster supporting two bands):

- The total of 24 filters is distributed between the two bands.
- The number of filters available for each band can be configured in the Band Info tab.

To configure the signal level and channels

1. In the left pane, click the **700/800** item.
2. For dual-band boosters, verify the number of channels allocated to each band:
 - Click the **Band Info** tab. The available filters are displayed in the **Band Information** area.



Figure 4-8. Configuring Number of Filters per Band

- In the **Channels for 700 band**, select the number of filters for the 700 band. The remaining available filters will be allocated to the 800 band.
- Click **Send** in the header.

3. To define the filters:
 - Click the **Control&Params** tab.
 - Click the button corresponding to the required band: **700** or **800**.

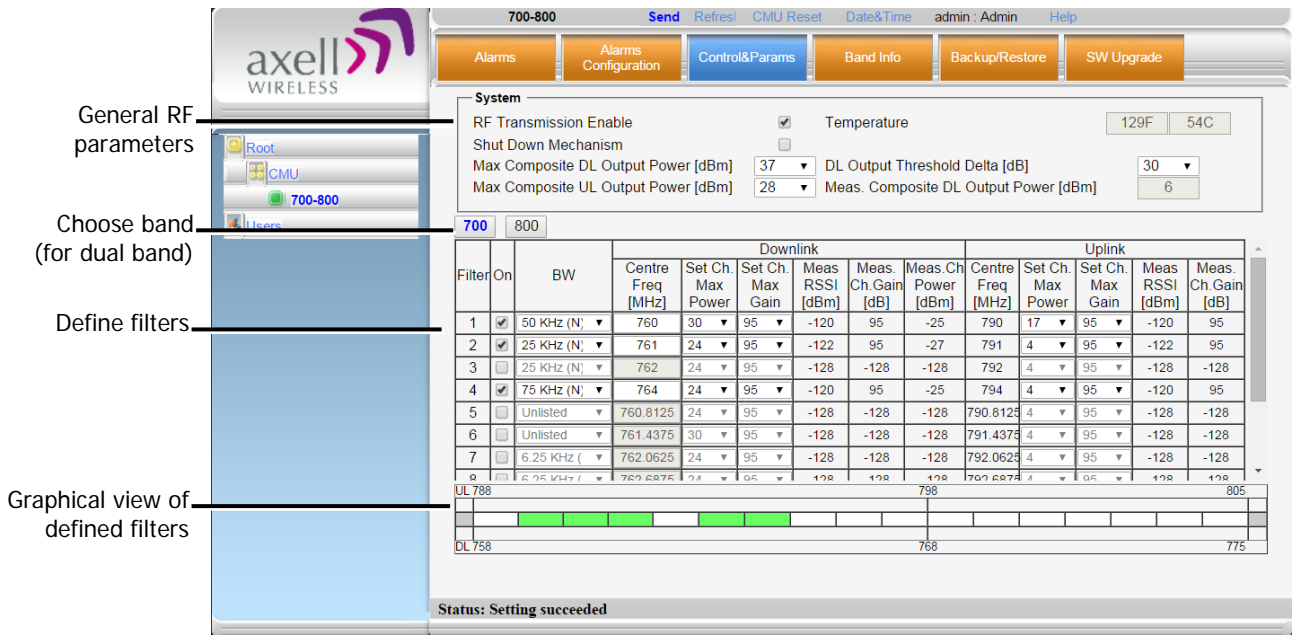

Figure 4-9. Sub-band Allocation Configuration

The displayed pane is relevant to the selected band. It is divided into three areas:

- System – overall parameters for the *selected service*.
- Filter definitions area.
- Graphical view of defined filters

4. Configure the general **System** parameters as follows:

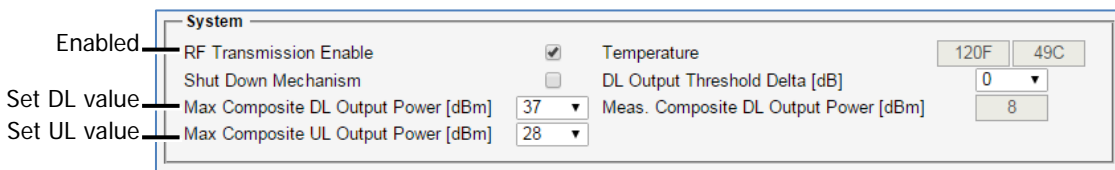

Figure 4-10. Control and Params Tab – Required System Parameters

- Verify **RF Transmission Enable** is checked (RF transmission ON).

NOTE: Under certain conditions related to the Shut Down mechanism, the RF transmission can be disabled (unchecked) by the system. The Shut Down mechanism is described in the next step - Optional System parameters).

- Set **Max Composite DL Output Power** – set according to your site requirements and click **Send**. The **Measured Composite DL Output Power** is displayed in the adjacent field.

NOTE: If the composite output power exceeds the defined value, the Smart-ALC feature begins working (refer to section 1.4 for more information on SALC).

- Set **Max Composite UL Output Power** – set according to your site requirements and click **Send**.

5. You may modify the following **System** parameters – Shut Down Mechanism (disabled by default) and DL Output Threshold Delta (set to '0' be default):

- **Shut Down Mechanism** – if enabled, the system automatically disables RF transmission if an excessively high input power (from the BTS side) is detected for a specific period of time.

In that case, two operations are performed by the system:

- **RF Transmission Parameter** is unchecked (transmission is OFF)
- **System Mute** alarm (Alarms tab) is generated (RED).

NOTE: If the high input power issue is resolved, then it is necessary to enable RF transmission by check-marking the **RF Transmission Enable** parameter. In addition, reset the **System Mute** alarm (click Ack).

- **DL Output Threshold Delta (dB)** - delta from DL Output Power, below which the alarm 'Donor power is too low' is activated.

6. Enable the available filters and set the bandwidth as follows:

- Checkmark to **ON** each filter row. The corresponding options will be available.
- Select the **BW** (bandwidth).

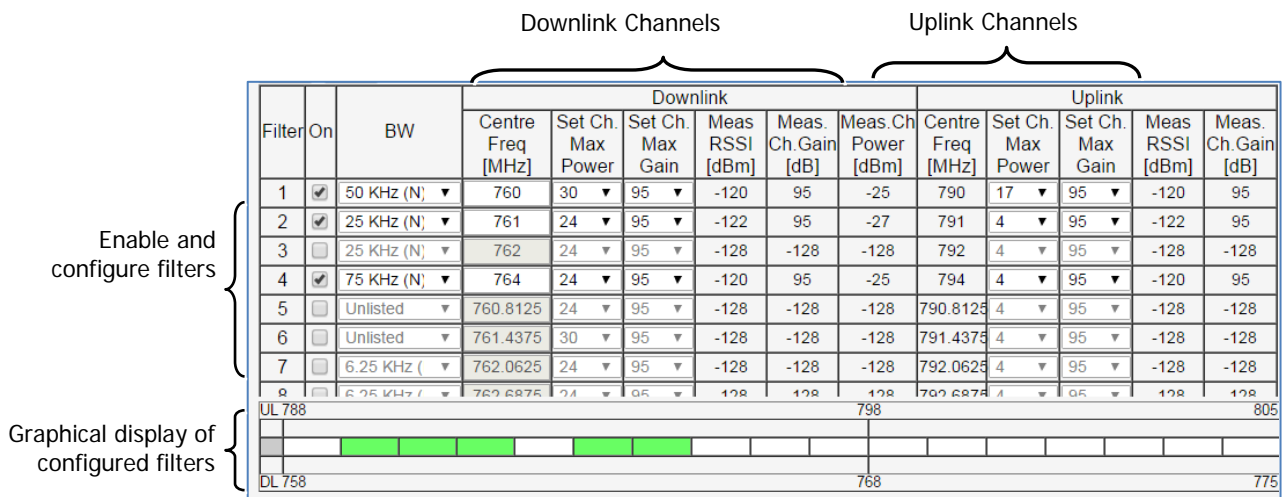

Figure 4-11. Control and Params Tab – Enabling and Configuring Filters

7. Set the **DL** parameters for the selected filter:

- **DL Centre Freq** - the resulting bandwidth will automatically be graphically displayed and the corresponding Uplink Center frequency will automatically be allocated.
- **Max Ch Max Power** – set to maximum level by default. Modify as needed.

You may want to click **Send** after each filter definition and view the measured Channel Power and the Composite Output Power (in the System are at the top of the screen).

- **Max Ch Max Gain** – set to maximum by default. Modify according to the measured/calculated input power and isolation measurements.

Recommended Maximum Gain setting is approximately 16 dB less than the isolation between the service and donor antennas.

More information on **Downlink** sub-band parameters

- DL Measured RSSI - measured DL signal.
- DL Measured Ch. Gain - measured DL Gain (dB) for the selected sub-band.
- DL Measured Ch. Power - measured Power (dBm) for the selected sub-band.

8. Set the **UL** parameters for the selected filter:

(The uplink channels **and their values** are automatically allocated according to the downlink channel definitions.)

- Set **Max Ch Max Power** – by default, the power is set to maximum level. Modify as needed.

You may want to click **Send** after each filter definition and view the measured Channel Power and the Composite Output Power (in the System are at the top of the screen).

- Set **Max Ch Max Gain** - change the default value (maximum) according to the measured/calculated input power and isolation measurements.

Recommended Maximum Gain setting is approximately 16 dB less than the isolation between the service and donor antennas.

9. Click **Send** (top window area option).

10. After the channels have been configured and the required coverage is attained for the location, verify that no Alarms are generated:

- Click the **Alarms** tab
- Verify that all the indicators are GREEN in the Alarms tab

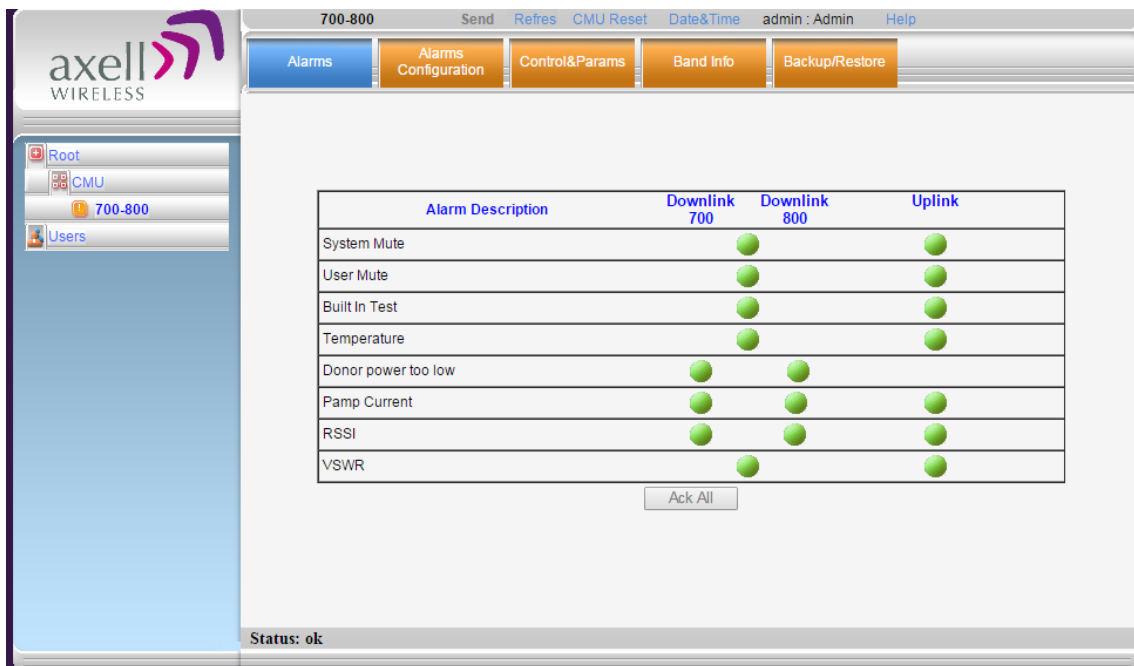

Figure 4-12. Alarms Dialog

4.4 Date and Time Settings

NOTE: It is important to set the correct date and time on the unit since this provides the timestamp for each logged event and alarm. This operation requires resetting the Booster.

To set the Boosters date and time

1. Click on **Date & Time** in the **Operations Items** bar (4.2.2.1). The following dialog appears.

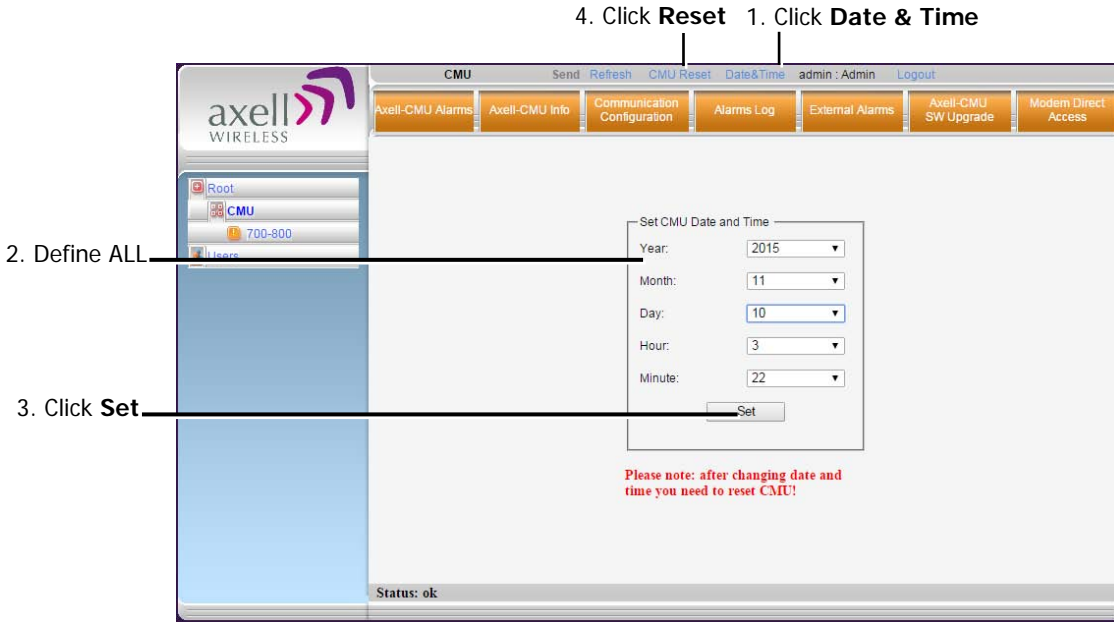

Figure 4-13. Date & Time Settings Dialog

2. Set all the date and time parameters.
3. Click on **Set** in the dialog.
4. Click the **CMU Reset** button in the Operations Bar.

4.5 External Alarms Configuration

The Booster supports one external alarm – from an external source or from the Booster or UPS.

To configure external alarms

1. In the left pane, click on the **CMU** option and select the **External Alarms** tab. The following dialog appears.

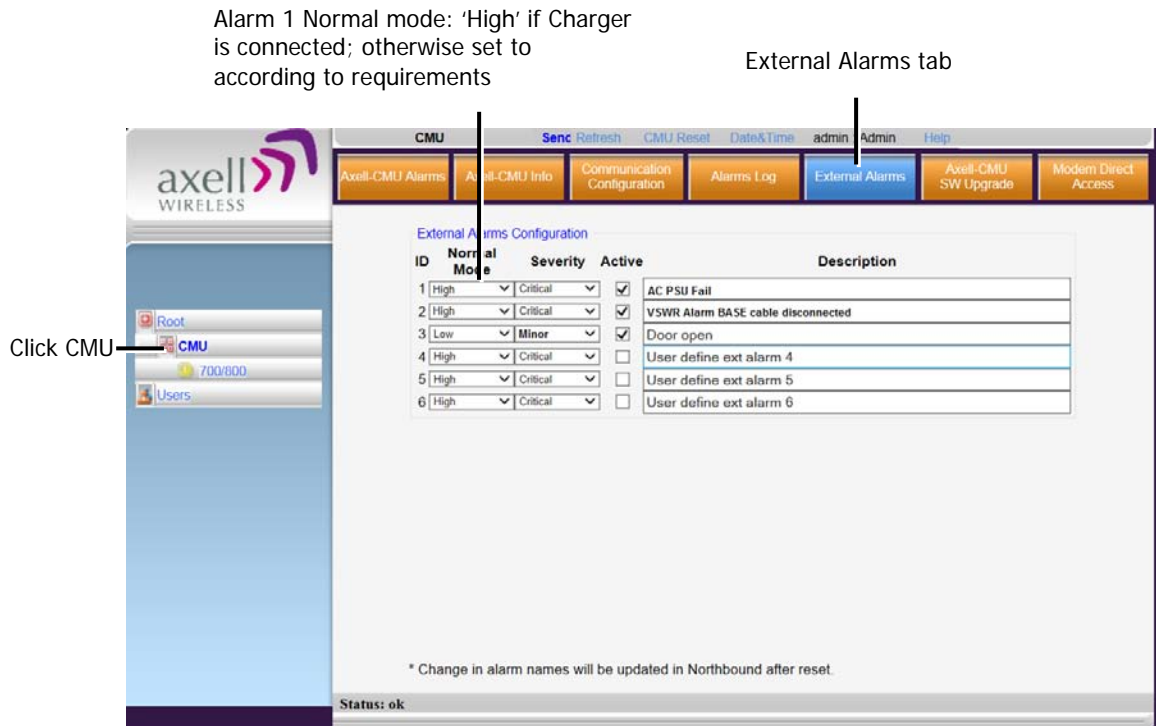

Figure 4-14. External Alarm Configuration Dialog

2. Set **Alarm-1 (EXT 1)** Normal mode as follows:
 - If an external alarm from the Battery Charger is connected to the Booster (section 3.4.3), set **Normal = High**.
 - If any other device (i.e. UPS) is connected, set the alarm according to the device documentation.

NOTE: Triggered external alarms are displayed in the **CMU-Alarms** tab.

4.6 IP Address and SNMP Notifications

This section describes how to set up the booster's IP Address and SNMP notifications management

To configure the IP Address and SNMP Notifications

1. Click on **CMU** in the left pane and select the **Communication Configuration** tab. The following screen appears.

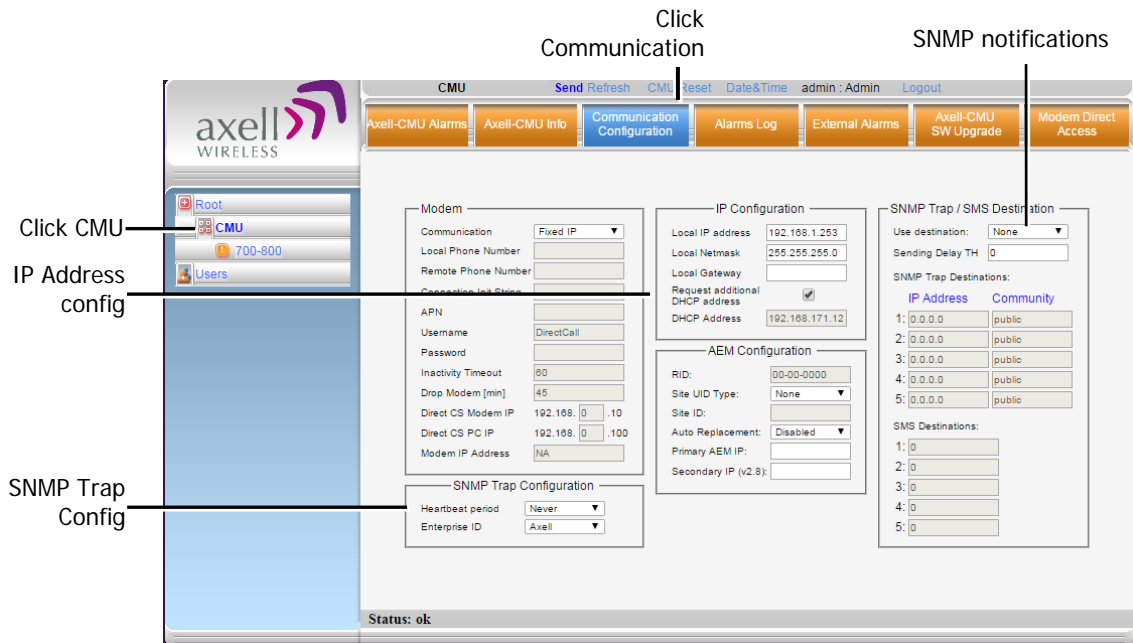



Figure 4-15. Communication Configuration Dialog

The following areas are relevant to this Booster installation.

| Area | Description |
|-------------------|--|
| IP Configuration | Used to define Static IP Address and DHCP Address. |
| SNMP Trap options | This includes enabling SNMP Trap options and defining the relevant parameters. |

4.6.1 Configuring the IP Address

The Booster supports both Static and DHCP addresses. A unique technology enables applying both types to the *same* Ethernet port. Both addresses may enable local and remote management.

 **ATTENTION!!** The Local IP Address is a static address assigned by the user to the system. The default Static IP address is **192.168.1.253**. It is highly recommended to preserve this setup. In case of a change, make sure you record the newly assign IP.

To configure the Booster IP address

1. Click the left pane **CMU** item and select the **Communication** tab.
2. To assign the unit a **Local IP Address**:
In the **IP Configuration** area, assign the unit the Local IP address, Netmask and Gateway parameters provided by your system administrator.

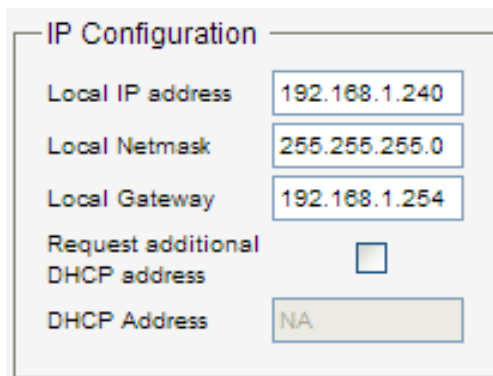

The screenshot shows the 'IP Configuration' form with the following values:

| | |
|---------------------------------|--------------------------|
| Local IP address | 192.168.1.240 |
| Local Netmask | 255.255.255.0 |
| Local Gateway | 192.168.1.254 |
| Request additional DHCP address | <input type="checkbox"/> |
| DHCP Address | NA |

Figure 4-16. Network Settings

3. To configure the booster to operate with a DHCP Server:
 - Checkmark Request Additional DHCP Address.
 - The assigned address can be seen in the DHCP Address field.

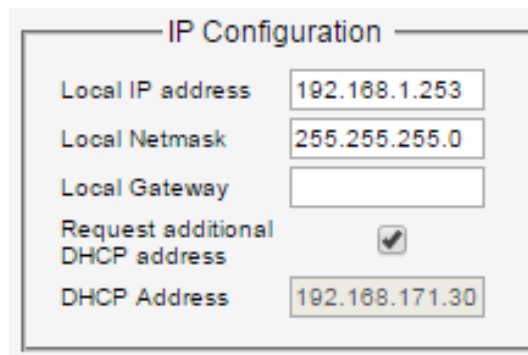

The screenshot shows the 'IP Configuration' form with the following values:

| | |
|---------------------------------|-------------------------------------|
| Local IP address | 192.168.1.253 |
| Local Netmask | 255.255.255.0 |
| Local Gateway | |
| Request additional DHCP address | <input checked="" type="checkbox"/> |
| DHCP Address | 192.168.171.30 |

Figure 4-17. Network Settings

4.6.2 SNMP Trap Configuration

The Booster can be configured provide fault notification by sending traps to up to five defined IP addresses each time a fault is triggered. The traps are sent at the defined heartbeat frequency and can be sent with a Sending Delay.

To set SNMP Trap Destination parameters

1. Click the left pane **CMU** item and select the **Communication** tab.
2. In the **SNMP Trap / SMS Destination** area, set the **Use Destination** field to the **SNMP** option

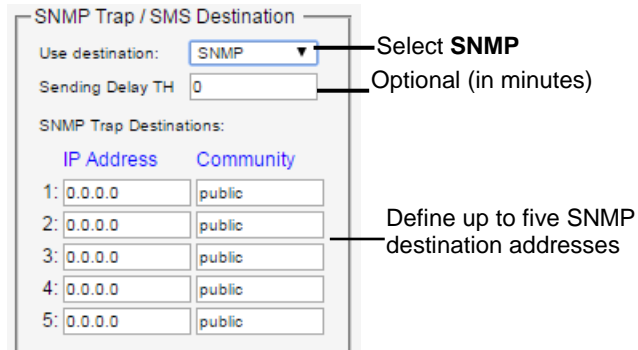

3. In the **Use Destination** field, select the **SNMP** option
4. For each destination:
 - Define the IP Address (where the IP addresses should be in the same subnet as the booster).
 - Define the Community names (default = public) of the computers to which traps will be sent.
5. **Sending Delay TH (Optional)** - by default, there is no sending delay ('0' value) and the alarm is continuously sent as long as the fault exists.
By configuring the Sending delay TH, the same alarm is sent again, only if the fault persists for the configured (minutes) time period.
6. In the **SNMP Trap Configuration** area, in the **Heartbeat Period** field, define the frequency (in minutes) at which traps will be sent. *It is recommended to maintain the Enterprise ID value as Axell.*

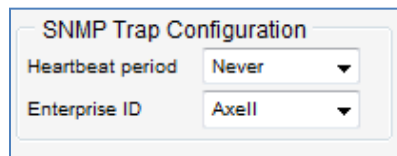

7. In the window Operations Bar, click **Send**.

4.7 Changing Password

For security, it is recommended to change the password of the Administrator.

To change the administrator password

1. From the left pane, select **Users**. The list of users is displayed in the User's Pane.

| Login Name | First Name | Last Name | Role | | |
|------------|------------|-----------|----------|------|-----|
| admin | admin | user | Admin | Edit | |
| operator | operator | user | Operator | Edit | Del |

Add User

2. In the **admin** row, click **Edit** and modify the relevant information – specifically the password.

Add User

Login Name

First Name

Last Name

User Role Admin

Password

Verify Password

Figure 4-18. Add User

3. Enter the **Password** and in **Verify Password** enter the password again for verification.
4. Click **OK**.

5 ADMINISTRATIVE OPERATIONS

The following administrative operations are described in this section:

- User Management – defining and changing users and passwords.
- Viewing the Booster information such as software and hardware versions, serial number.
- Software upgrade

5.1 User Management

This section describes how to perform the user management operations. By default, *two* users belonging to one of three authentication levels are defined on the Booster. You may add new users, modify or delete existing users.

5.1.1 User Levels

Two user levels are available:

- Admin – has access to all administration and configuration options, including user management. (Default Password **admin** and default User Name **admin**.)
- Operator – has access to all configuration options *except* for the Users list or the Loaders screen.

5.1.2 Viewing the List of Defined Users

To display the User Administration pane

From the left pane, select **Users**. The list of users is displayed in the Configuration Pane according to the identifying information and authentication level (Role).

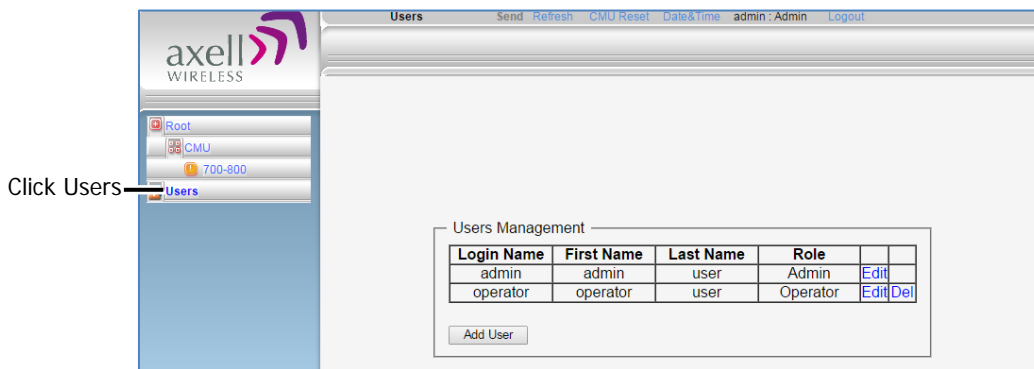

Figure 5-1. User Administration Pane

The following table provides a description of the Users dialog options.

| Option | Description |
|-------------------|---|
| Add User (button) | Adds a new user with to user defined access level and password. |
| Del(ete) | Deletes a selected user from the list. |
| Edit | Enables changing the definitions of an existing user. |

5.1.3 Adding Users

NOTE: User name and password entries are case sensitive.

To add a user

1. From the left pane, select **Users**. The list of users is displayed in the User's Pane.
2. From the User's Pane, click **Add User**. The Add User dialog box is displayed.

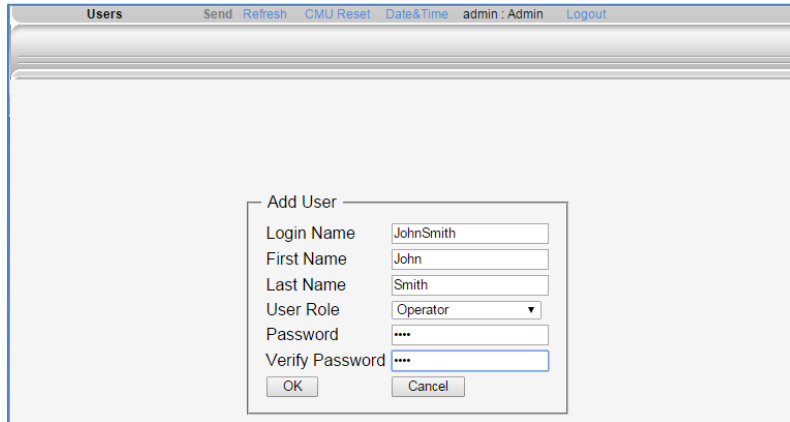

Figure 5-2. Add User

3. Enter the **Login Name** – name used by user to login.
4. Type the user's **First Name** and **Last Name** – used to identify the user.
5. Select the **User Role** – access level. This defines the operations that the user will be able to perform.
6. Enter the **Password** and in **Verify Password** enter the password again for verification.
7. Click **OK**.

5.1.4 Editing a User

To modify user definitions

1. From the left pane, select **Users**. The list of users is displayed in the **User's Pane**.
2. Select the **User** to be edited in the list.
3. Click **Edit**. The user definitions dialog appears.
4. Make the required changes and click **OK**.

5.1.5 Deleting a User

To delete a user

1. From the left pane, select **Users**. The list of users is displayed in the User's Pane.
2. Select the User to be deleted in the list.
3. From the User's Pane, click **Del**. A verification dialog box is displayed.
4. Respond by clicking **Yes** to delete the User from the list.

5.2 General Parameters

Two panes provide general information and configuration options:

- CMU Info tab – booster level parameters
- Band Info tab – band level parameters with a dedicated tab per band

5.2.1 Booster Level General Parameters

Use the **CMU Info** screen to do the following:

- View the hardware and software versions of the booster
- Set log level and alarm thresholds

To access the **CMU Information** window

1. In the left pane, select **CMU** and click the **CMU Info** tab.
2. You may define the following parameters:
 - **Log Level** - sets the minimum fault level that is logged.
 - **CMU name** – identifiable user-defined name.
 - **Auto Ack** – when enabled, alarms are deactivated automatically when the corresponding fault no longer exists

(Other fields provide version and identification information.)

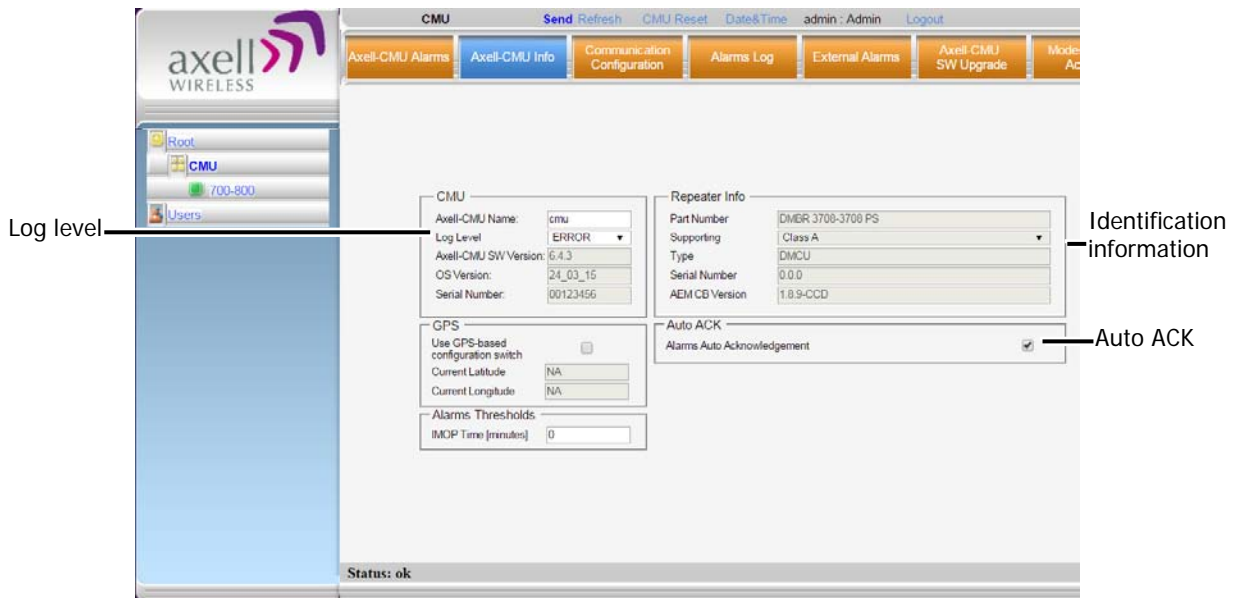

Figure 5-3. CMU Level Info

5.2.2 Band Level General Parameters

Use the Band Info tab to perform the following operations:

- View identification information and build versions
- View valid filter bandwidth
- Allocate the number of filters for each Band

To access the [Booster Information window](#)

1. From the left pane, select the **700-800** item.
2. Select the **Band Info** tab. The relevant parameters are displayed.

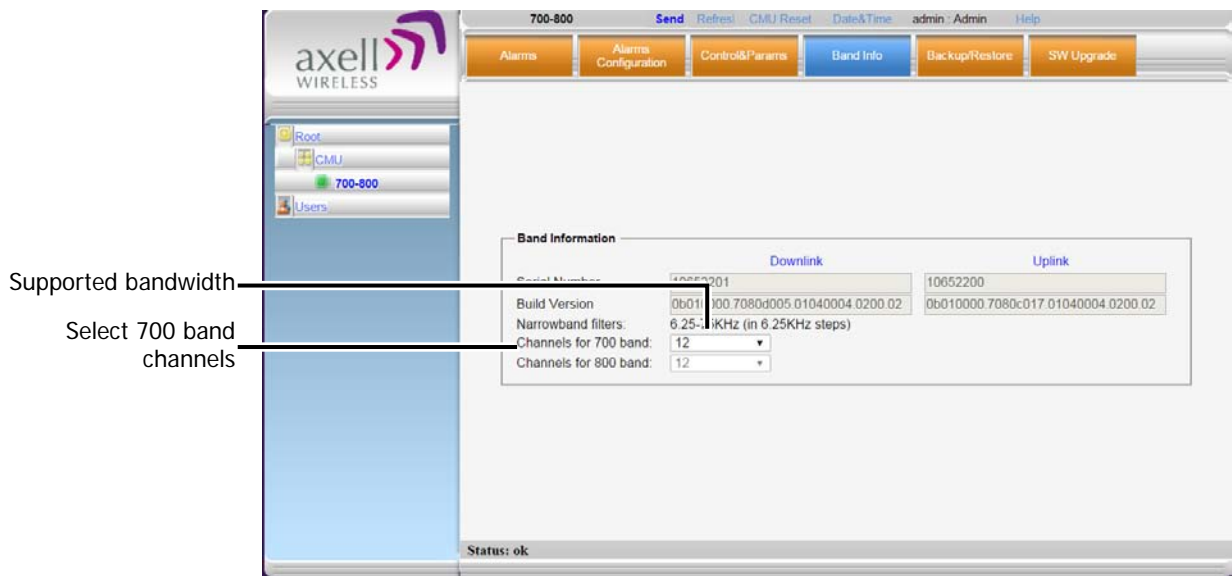

Figure 5-4. Band Level Information

3. To change the number of channels allocated to each band (24 channels for both bands):
 - Select the number of **channels for the 700 band**.
 - The remaining available channels (for a total of 24) is allocated to the **800 band**.

5.3 Band-Level Configuration Backup/Restore

The Web GUI management application enables the backup and restore of the band level configuration options. A number of configuration files can be stored on the Booster for access and restoring at any time. The procedures are performed via the **Backup/Restore** tab.

5.3.1 The Backup/Restore Tab

To access Backup/Restore tab

In the left pane, click the **700-800** item and click the **Backup/Restore** tab. The following screen appears.

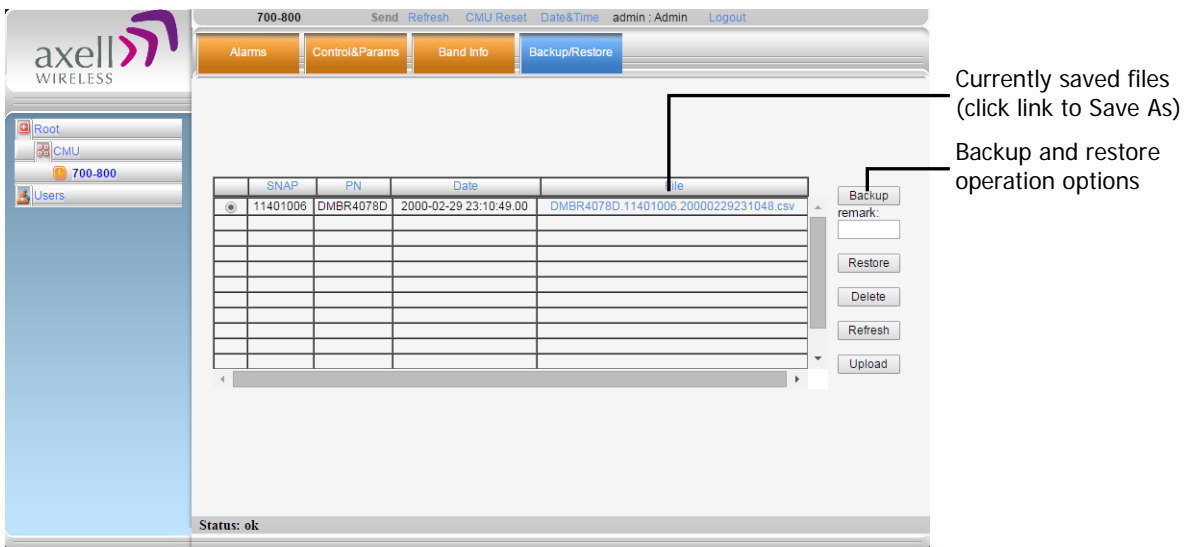

Figure 5-5. Backup and Restore

The file management buttons provide the following options:

| Item | Description |
|----------------|--|
| Backup | Backup the currently running configuration file to a selected location. The file will be added to the list. |
| Remark | User defined name that will be assigned to the file saved using the Backup file. (Instead of the system assigned name). |
| Restore | Select and upload an existing band level configuration file. |
| Delete | Deletes the <i>selected</i> file from the list. |
| Refresh | Refreshes the displayed list of files. |
| Upload | Enables uploading a configuration file from another location to the Booster. |
| File | Click links to download files and save to another location. |

5.3.2 Backup Band Configuration

To backup the current configuration

1. In the left pane, click the **700-800** item and then click the **Backup/Restore** tab.
2. To assign the configuration file a recognizable name, enter a name in the **remark** field. Otherwise, the file will be assigned a name by the system.
3. Click the **Backup** button located on the right-hand side of the tab.
4. The file will be added to the table displayed in the Backup/Restore tab.

Note: The file name (under File) is a link that enables uploading the file to another location.

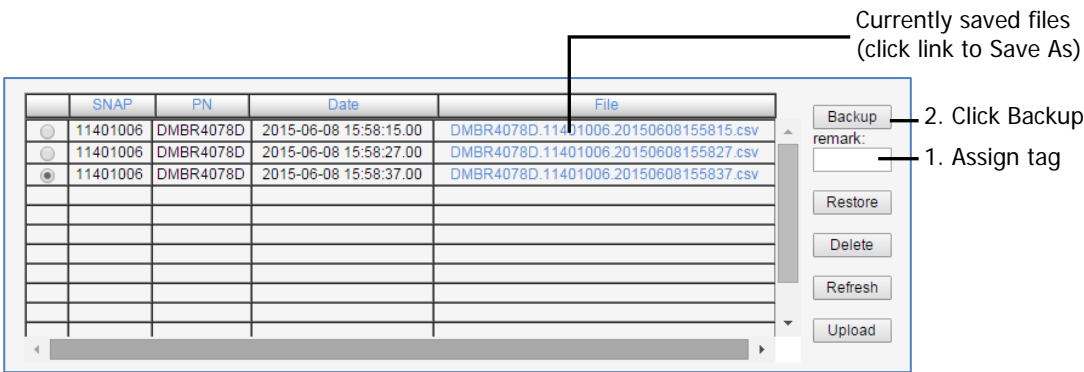

Figure 5-6. Backup Booster Info

5.3.3 Restoring Band Configuration

To restore previous configuration

1. In the left pane, click the **700-800** item and then click the **Backup/Restore** tab.
2. Select the required configuration file (enable corresponding radio button) from the available list in the Backup/Restore tab.
3. Click the **Restore** button.

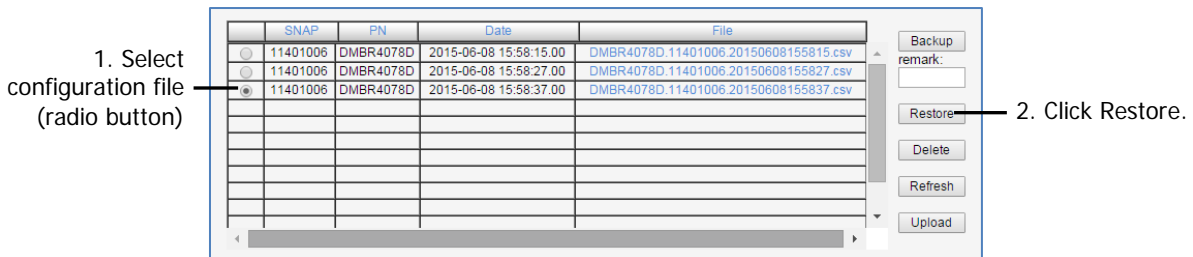

Figure 5-7. Restore Band Configuration

4. Click on the **Control and Params** tab and verify that the required configuration settings have been restored.

5.3.4 Uploading Band Configuration File

To upload configuration file to Booster

1. In the left pane, click the **700-800** item and then click the **Backup/Restore** tab.

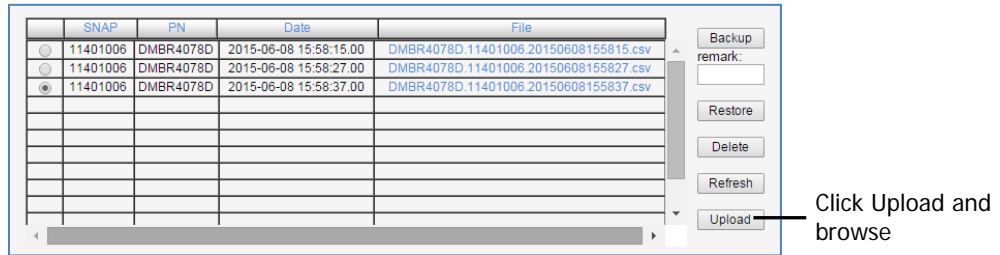

Figure 5-8. Upload Configuration File

2. Click the **Upload** button.
3. Select the file from the Browse dialog and click **Open**.
4. The file will be listed in the Backup/Restore table.

5.3.5 Saving Configuration File to Computer

To save a configuration file from the list to a selected location

1. In the left pane, click the **700-800** item and then click the **Backup/Restore** tab.

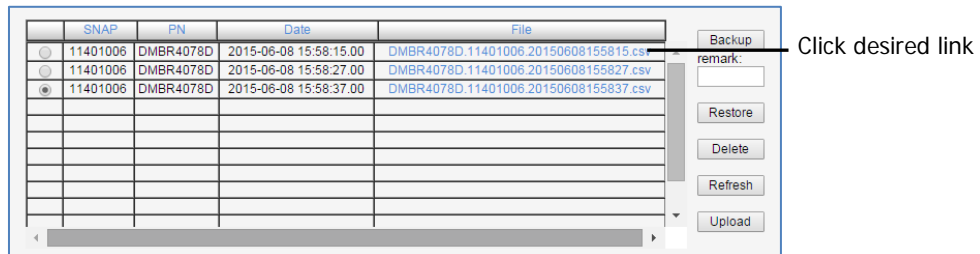

Figure 5-9. Save File in a Different Location

2. Select file from list.
3. Click the link in the **File** column.
4. Select the location in the Browse dialog

5.4 Software Upgrade

There are two separate software upgrade procedures:

- CCD software upgrade procedure
- Embedded software upgrade procedure

5.4.1 CMU Software Upgrade

The procedure described in this section is used to upgrade the repeater CCD.

NOTE: This procedure is performed for every new management version.

The CMU SW upgrade procedure consists of loading the new software version and installing it in the CMU. The CMU can store two versions on two separate data banks enabling restore to a previous version.

To Upgrade the CMU SW

1. If necessary, note the *currently* loaded **CMU SW Version** and **OS Version** by clicking the **CMU** option in the left pane and selecting the **Axell CMU Info** tab.

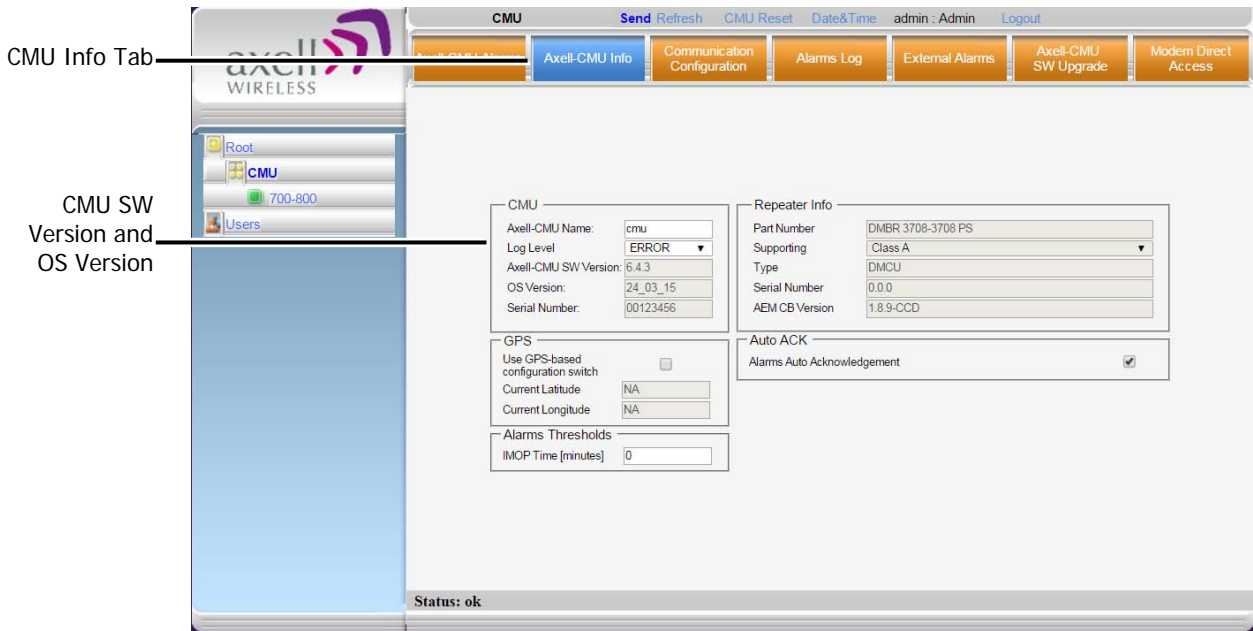

Figure 5-10. CMU-Info Tab Showing Currently Installed Versions

2. Click the **CMU SW Upgrade** tab. The Software Upgrade screen appears.

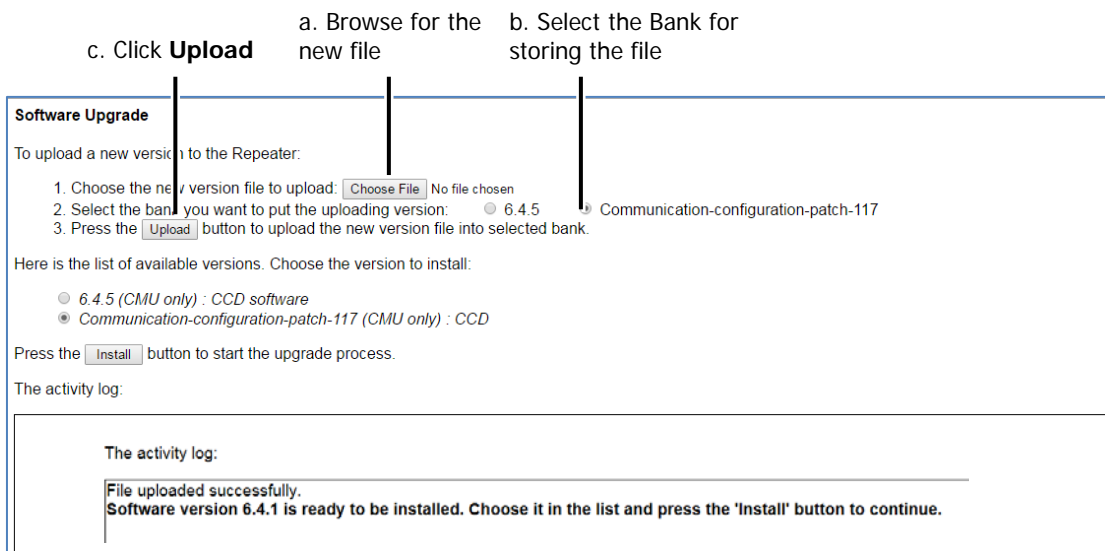

Figure 5-11. Select File for Uploading

3. Choose and save the new version file onto the Repeater:
 - Click **Choose File**, browse for the new software file and click **Open** (or **OK**) to upload the file. It will be displayed adjacent to the **Choose File** button.
 - **Select the bank where the file will be stored.**
(Before it is populated the bank will be named 'slot'. After it is populated, it will take on the name of the stored software version). Any existing software file will be replaced.
 - Click **Upload** to save the file to the selected bank (slot).
The available software files to choose from will be listed.
4. Choose the required software file and click **Install**.
5. The Activity Log will indicate status and upgrade completion.
6. Verify the newly updated **CMU SW Version** and **OS Version** by clicking the **CCD** option in the Tree Pane and selecting the **Axell CMU Info** tab.

5.4.2 Embedded Software Upgrade

The procedure described in this section is used to upgrade the embedded software version.

To upgrade the embedded software version

1. Note the current software version build currently installed on the repeater, by clicking the **Band** item in the left pane, and selecting the **Band Info** tab.



Figure 5-12. Band Info Tab Showing Currently Installed Build

2. Upload the file:
 - From the left pane, click the **Band** and choose the **SW Upgrade** tab.

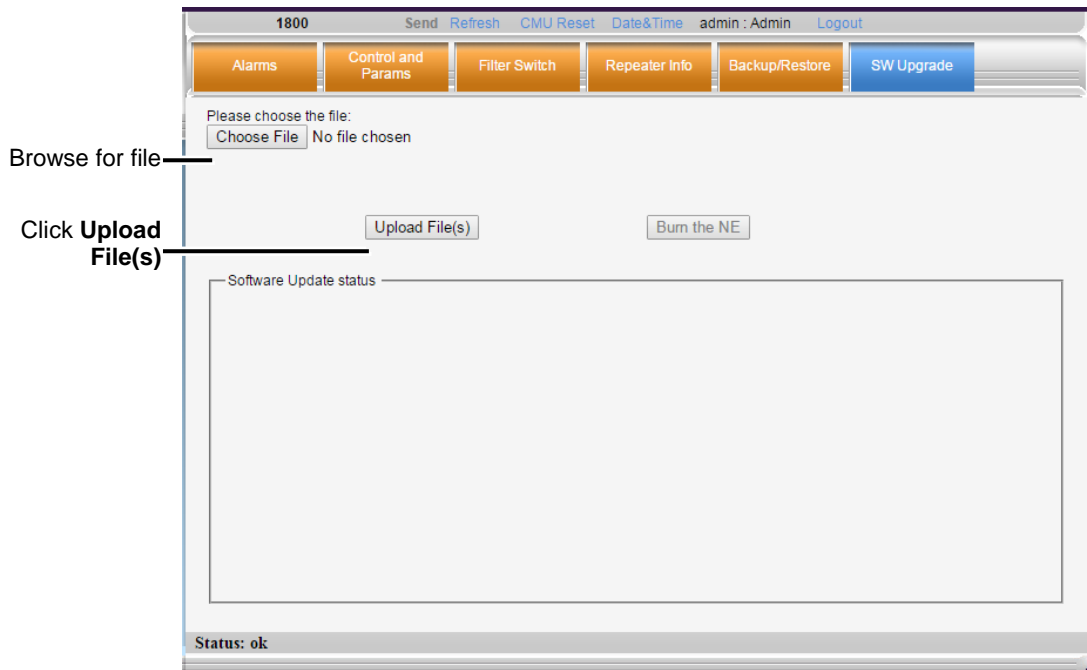

Figure 5-13. Upload Build File

- Click **Choose File** and browse for the new file. The new file name will be displayed.
 - Click **Upload File(s)**, and wait to the file to be loaded.
3. Burn the file into the NE:
- Click **Burn the NE** button.
 - Wait for several minutes for the burning process to complete. Upon successful completion, the following type of text will be displayed:

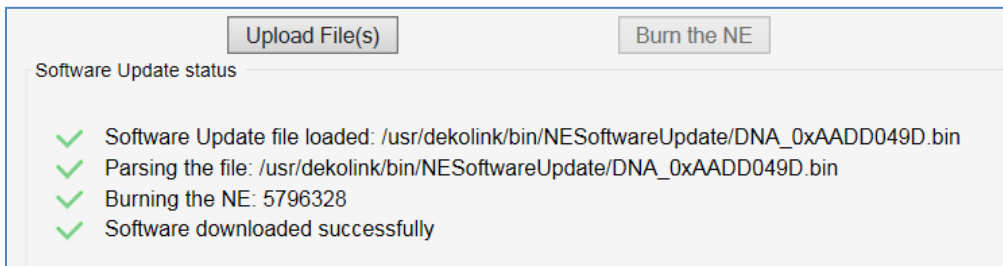

Figure 5-14. Example of Software Update Completed Messages

NOTE: If, during the Burning process, communication with the unit was lost, the upgrade process will continue all the same. Until the upgrade process is complete, any attempts to login to the unit will invoke the message "Can't perform set. The system is in Software Upgrade mode."

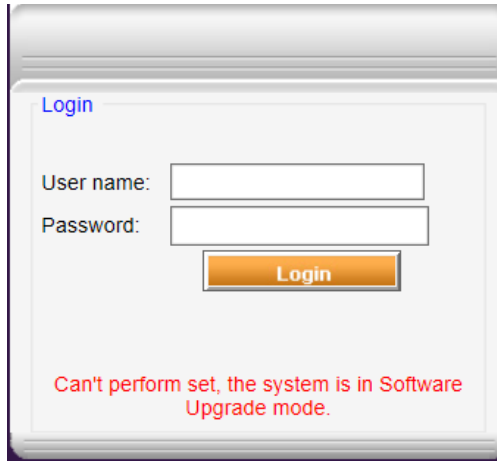

Figure 5-15. Response to Login Attempt During Upgrade

4. Verify the software version has been updated, by clicking the *Band* item in the left pane and selecting the **Band Info** tab.
5. In the left pane, click the *700-800* item and define the RF parameters for each band according to section 4.3.

System

RF Transmission Enable Temperature 129F 54C

Shut Down Mechanism

Max Composite DL Output Power [dBm] 37 DL Output Threshold Delta [dB] 30

Max Composite UL Output Power [dBm] 28 Meas. Composite DL Output Power [dBm] 6

| Filter | On | BW | Downlink | | | | | Uplink | | | | | |
|--------|-------------------------------------|------------|-------------------|-------------------|------------------|------------------|---------------------|-----------------------|-------------------|-------------------|------------------|------------------|---------------------|
| | | | Centre Freq [MHz] | Set Ch. Max Power | Set Ch. Max Gain | Meas. RSSI [dBm] | Meas. Ch. Gain [dB] | Meas. Ch. Power [dBm] | Centre Freq [MHz] | Set Ch. Max Power | Set Ch. Max Gain | Meas. RSSI [dBm] | Meas. Ch. Gain [dB] |
| 1 | <input checked="" type="checkbox"/> | 50 KHz (N) | 760 | 30 | 95 | -120 | 95 | -25 | 790 | 17 | 95 | -120 | 95 |
| 2 | <input checked="" type="checkbox"/> | 25 KHz (N) | 761 | 24 | 95 | -122 | 95 | -27 | 791 | 4 | 95 | -122 | 95 |
| 3 | <input type="checkbox"/> | 25 KHz (N) | 762 | 24 | 95 | -128 | -128 | -128 | 792 | 4 | 95 | -128 | -128 |
| 4 | <input checked="" type="checkbox"/> | 75 KHz (N) | 764 | 24 | 95 | -120 | 95 | -25 | 794 | 4 | 95 | -120 | 95 |
| 5 | <input type="checkbox"/> | Unlisted | 760.8125 | 24 | 95 | -128 | -128 | -128 | 790.8125 | 4 | 95 | -128 | -128 |
| 6 | <input type="checkbox"/> | Unlisted | 761.4375 | 30 | 95 | -128 | -128 | -128 | 791.4375 | 4 | 95 | -128 | -128 |
| 7 | <input type="checkbox"/> | 6.25 KHz (| 762.0625 | 24 | 95 | -128 | -128 | -128 | 792.0625 | 4 | 95 | -128 | -128 |
| 8 | <input type="checkbox"/> | 6.25 KHz (| 762.6875 | 24 | 95 | -128 | -128 | -128 | 792.6875 | 4 | 95 | -128 | -128 |

UL 788 798 805

DL 758 768 775

Status: Setting succeeded

Figure 5-16. Filter Configuration

6 MONITORING AND TROUBLESHOOTING

The Booster provides panel LEDs, external alarms connectors and two types of (WEB GUI) alarm screens used for viewing status and for alerting and troubleshooting the causes of Booster faults or failure.

The following sections provide a description of the various alarms, a description of possible faults and corrective actions. In addition, the relevant screens for viewing the alarms are described.

6.1 Booster Panel LEDs

Two status LEDs are located on the Booster panel:

- Upper LED - UL status for one or two bands
- Lower LED - DL status for one or two bands

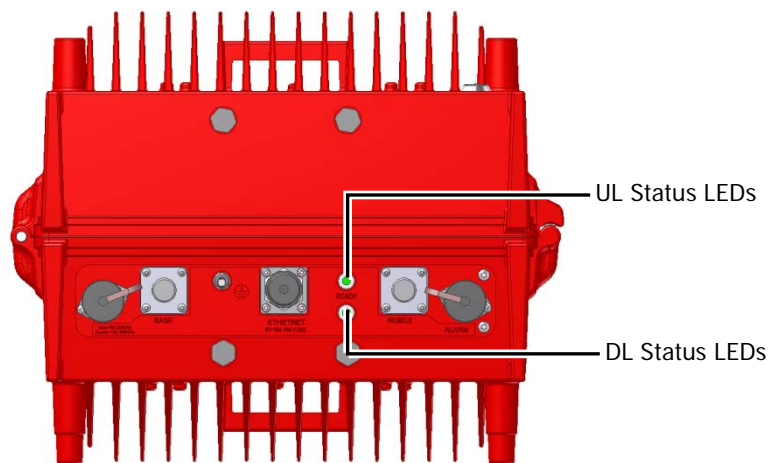

Figure 6-1. UL and DL Status LEDs located on Underside Panel

The LEDs provide the following information on status and possible faults:

| Color | Description | Corrective Action |
|---------------------|---|---|
| Green | Normal (UL or DL) operation | - |
| Red | Power failure (in UL or DL) | Corrective action: Turn off the Booster (this action causes a reset of the function), and turn it on anew. If the fault resumes, replace the unit. |
| Blinking Orange/red | Mute - either user- or system-initiated. (System initiated mute may be due to isolation problem or temperature). | Check gain of the booster, if gain is minimum, then it is an isolation problem. Improve isolation. Turn OFF the Booster (resets the function), and turn it ON again. If the fault resumes, replace the unit. |

6.2 Booster Panel Alarms Connector

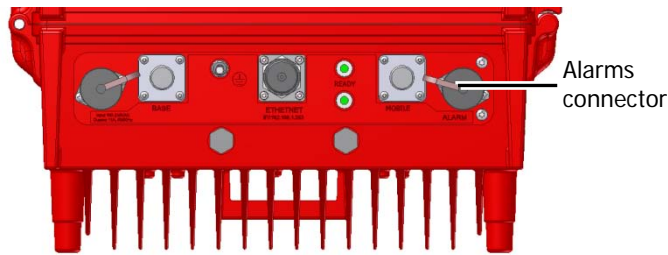

Figure 6-2. UL and DL Status LEDs located on Underside Panel

The booster front panel Alarms connector supports the following alarms:

- Two dry-contact alarms connected to the **Fire Department Control Box**:
 - **VSWR Out Alarm** (pins 3 and 6)
 - **Summary Alarm** (pins 7 and 4)
- **Optional**: one external alarm that may be connected to one of the dry-contact alarms on the **UPS or Battery Charger**: **EXT Alarm IN** (pins 1 and 5)

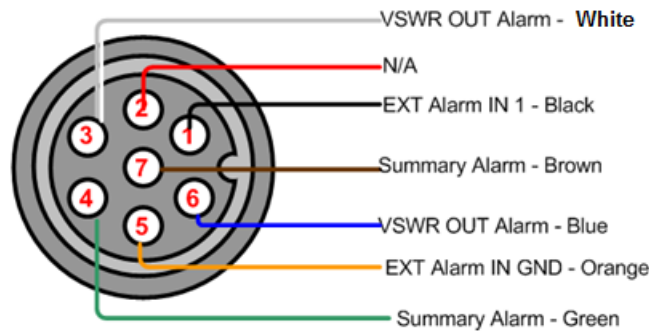

Figure 6-3. Booster Alarm Connector Pinout

| Pins No. | Signal Name |
|----------|---|
| 1 and 5 | External Alarm #1 – optional. Can be used to provide SNMP alarm notification for one of the dry-contact alarms of the UPS or Battery Charger. The alarm setting and description is user configured according to section 4.5 |
| 3 and 6 | Dry Contact VSWR Alarm . Triggered under one of the following conditions: <ul style="list-style-type: none"> • Donor antenna cable is disconnected (no load on Donor antenna port); • Incompatible VSWR is detected on the UL signal transmitted via the Donor antenna. • Service antenna cable is disconnected (no load on Service antenna port), but a DL signal (from the BTS) does exist. |
| 4 and 7 | Dry Contact Summary Alarm . Triggered under one of the following conditions: <ul style="list-style-type: none"> • PA current from FF; • Temperature High or Built-In-Test; • Power failure; • No DC power input. |

6.3 WEB GUI Alarms Screens

Three WEB GUI alarms screens are provided:

- Band level (700/800) Alarms screen
- CMU level Alarms screen
- Alarms log

6.3.1 700-800 Alarms Screen

The Alarms tab displays any alarms generated by the band(s).

To view the alarms

From the left pane, select the **700-800** item and choose the **Alarms** tab. The relevant alarms are displayed.

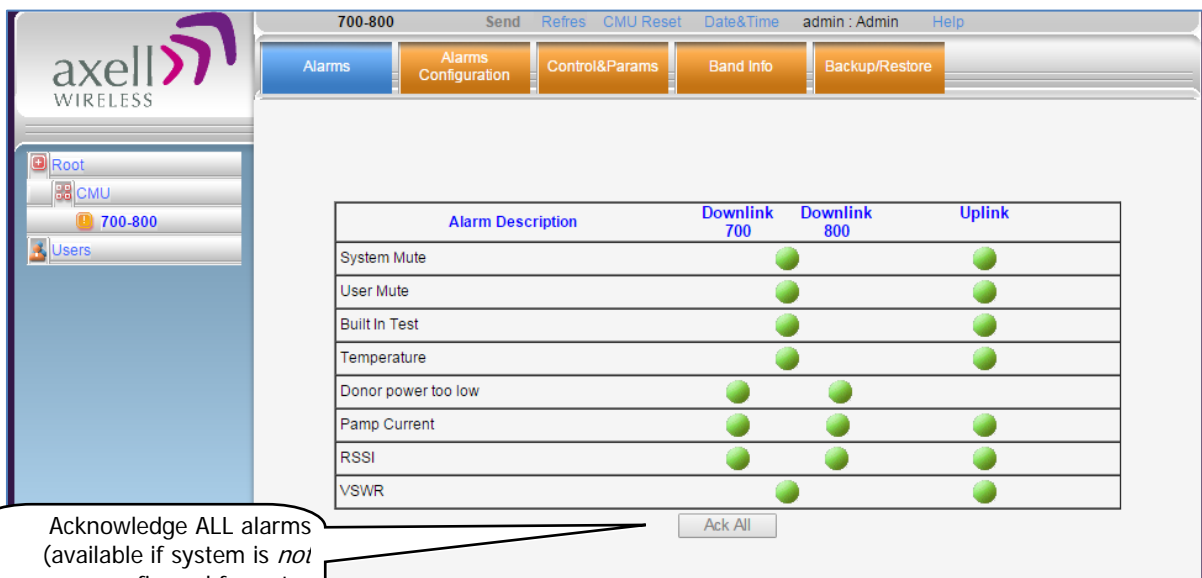

Figure 6-4. Band Level Alarms Status Tab

Note the following:

- When at fault, each generated alarm is displayed according to the factory set severity value for that alarm, as Minor (yellow), Major (orange) or Critical (red). The alarm settings can be modified via the **Alarms Configuration** tab. Section 6.5.
- The **Ack All** button is available only if the alarms are not configured to be automatically cleared by the system when the corresponding fault exists. The automatic acknowledgment can be modified via the **CMU Info** tab (see section 5.2.1).
- If **Ack All** is available, click it to reset ALL displayed alarms.

The alarms are described on the following page...

| Alarm | Fault and most probable cause and Recommendation |
|----------------------------|--|
| System Mute | <p>Description. Generates an alarm when Booster amplification is <i>automatically</i> muted.</p> <p>Possible causes: Temperature failure, Synthesizer failure, Hardware failure, High RSSI power DL/UL when the shutdown mechanism is on.</p> <p>Recommended action: Check the LED and other alarm from the Booster. Contact Cobham Wireless Support</p> |
| User Mute | <p>Description: Manual shutdown performed by operator from the Web GUI.</p> <p>Recommended action: Review unit's log</p> |
| Built In Test | <p>Possible causes: Hardware failure, Circuitry failure, Software failure</p> <p>Recommended action: Contact Cobham Wireless Support</p> |
| Temperature | <p>Description: Booster temperature is exceedingly high due to excessive external heat.</p> <p>Recommended action: Check the Booster case for external causes (sun, hot environment, air flow is blocked). Eliminate the reason for excessive heat.</p> |
| Donor Power Too Low | <p>Description: Signal from the Donor antenna (DL) is too low - relatively to the desired output signal configured by the user.</p> <p>Recommended action: Check the Donor/Base connections and antenna position. Check the signal level of the Donor/Base antenna. If the alarm is still raised, then you can raise, the value of the DL Output Threshold Delta[dBm] as needed.</p> |
| (PAmp) Current | <p>Description: Power Amplifier current is not within limits (too high or too low). If the Mute option is enabled, then this is not a fault since it indicates low Power Amplifier current caused by the mute.</p> <p>Recommended action: Check the LEDs status in the Booster and Contact Cobham Wireless service support.</p> |
| RSSI | <p>Description: Generates an alarm when a high <i>donor</i> input signal causes system gain reduction</p> |
| VSWR | <p>Description: This alarm is triggered when the return loss of the Downlink or Uplink antenna or cable connection exceed the allowed limit.</p> <p>This alarm provides an indication of the status of the cable/antenna connected to the antenna. If a cable/antenna is defective, the VSWR is decreased and the alarm is triggered.</p> <p>Recommended action: Check the cable.</p> |

6.3.2 CMU Alarms Screen - Activated Alarms

The CMU Alarms screen shows any activated Alarms, including any activated dry-contact alarms.

To view activated alarms

Click on **CMU** in the left pane and select the **CMU Alarms** tab. The following screen appears.

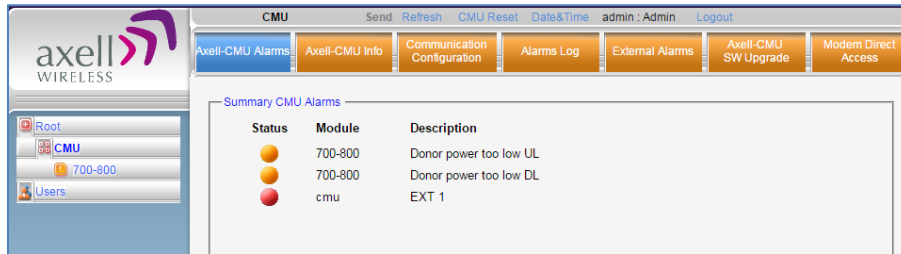

Figure 6-5. CMU Info Tab Showing Activated Alarms

6.3.3 Alarms Log

The CMU maintains log files listing every alarm triggered in the Booster. These are displayed in the Alarms Log screen. This screen provides an analysis tool to get information of any event that has occurred, its originator, when, if they return, and their type.

NOTE: Time of occurrence of the events is set according to the Booster clock (4.4).

To view the CMU log screen:

Click on **CMU** in the left pane and select the **Alarms Log** tab. The following screen appears.

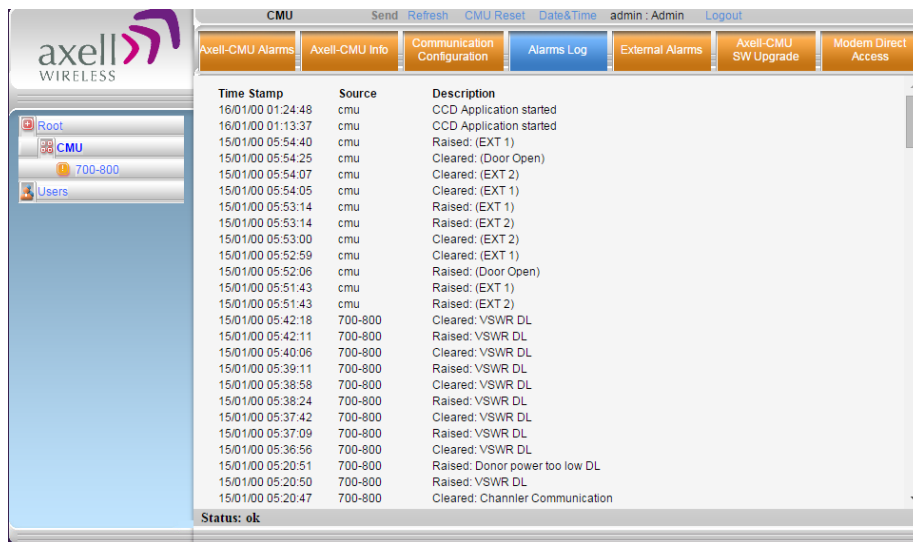

Figure 6-6. CMU Log Screen

| Item | Description |
|-------------|--|
| Time Stamp | The date and time the alarm was created |
| Source | ID of Network Element |
| Description | Description of event that caused the alarm |

6.4 Faults and Summary of Activated Alarms

The table in this section summarizes the fault descriptions and the various alarms generated under the given fault conditions.

Depending on the fault, alarms are activated on any of the following interfaces:

- External alarms connector – connector pinout is described in section 6.2
- Axell CMU Alarms screen – described in section 6.3.2.
- Band dedicated (700-800) Alarms screen – described in section 6.3.1

NOTE: Alarm connector pin 4&7 and 3&6 are normally **closed** (no active alarms) and open when an alarm is activated.

| Fault Description | Activated Alarms |
|--|--|
| No DC input to the repeater. | External Alarms connector pins 4 and 7 are activated. |
| Donor antenna cable is disconnected (no load on Donor antenna port) | Two alarms are activated: <ul style="list-style-type: none"> • On the External Alarms connector - pins 3 and 6 are activated. • In the Axell CMU Alarm screen, the VSWR Alarm Base cable disconnected alarm is activated. |
| Incompatible VSWR is detected on the UL signal transmitted via the Donor antenna. | Four alarms are activated: <ul style="list-style-type: none"> • On the External Alarms connector - pins 3 and 6 are activated. • In the Axell CMU Alarm screen, two alarms are activated: <ul style="list-style-type: none"> • VSWR Alarm Base cable disconnected • VSWR Alarm Uplink • In the 700/800 Alarms screen, the VSWR alarm in the Uplink column is activated. |
| Service antenna cable is disconnected (no load on Service antenna port), but a DL signal (from the BTS) <i>is detected</i> by the Booster. | The two alarms below are immediately activated: <ul style="list-style-type: none"> • In Axell CMU Alarm screen, VSWR Alarm DL. • In the 700/800 Alarms screen, the alarm VSWR in the Downlink column is activated. Followed by the activation of this alarm: <ul style="list-style-type: none"> • On the External Alarms connector - pins 3 and 6. |

6.5 Modifying Alarm Severities

The Alarms Configuration tab is used to modify the factory set level (minor, major or critical) of specific alarms when they are activated.

To modify the Alarm Severities

- From the left pane, select **700/800** item and choose the **Alarms Configuration** tab.
- When activated due to a fault, the alarm is displayed in the selected color. The color corresponds to the alarm level.
- Each alarm can be set to one of the following levels: Minor (yellow), Major (orange) or Critical (red).

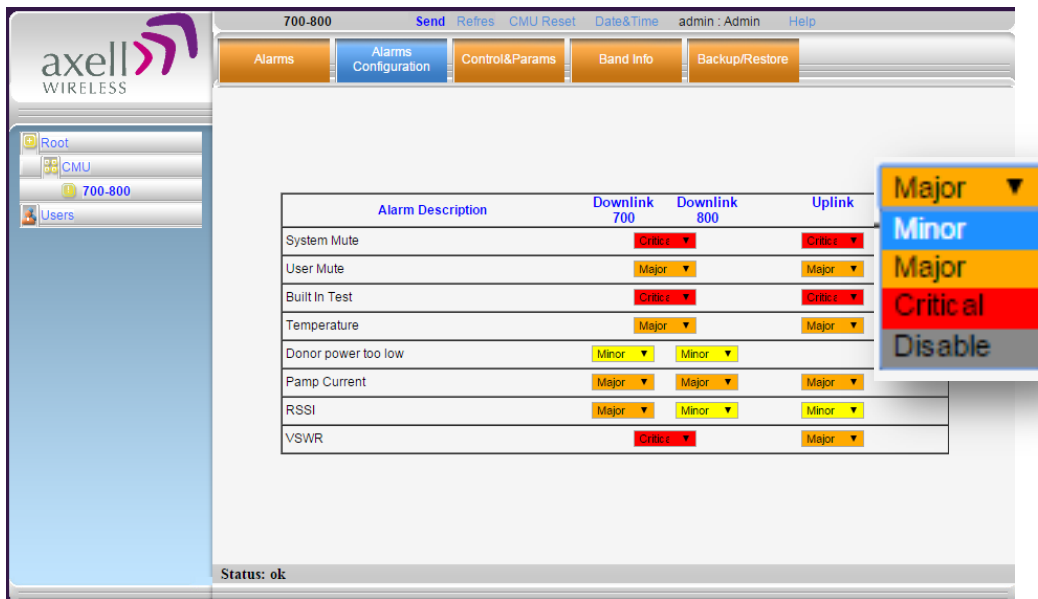

Figure 6-7. Modifying Alarm Severities

APPENDIX A – BOOSTER SPECIFICATIONS

| Electrical | Downlink | Uplink |
|--|---|--|
| Frequency Range: SMR 700MHz ⁽²⁾ SMR 800MHz ⁽²⁾⁽³⁾ | 763 - 775 MHz 851 - 869 MHz | 793 - 805 MHz 806 - 824MHz |
| Passband Gain | 55 to 95 dB Adjustable in 1 dB steps | |
| Passband Ripple | ± 2.5 dB | ± 2.5 dB |
| Gain attenuation range | 30 dB | |
| Filter BW (SMR 700MHz) ⁽¹⁾ Filter BW (SMR 800MHz) ⁽¹⁾ | Programmable 12.5KHz to 75KHz in 12.5KHz steps. | |
| Number of supported filters | Up to 24 per system | |
| Composite Output PWR SMR 700MHz | + 37dBm | + 27dBm |
| Composite Output PWR SMR 800MHz | 3708 models: + 37dBm 4008 models: +40dBm | 3708 model: + 27dBm 4008 models: +28dBm |
| Total RF Input PWR (no damage) | +10dBm | |
| Impedance Level | 50 Ohm | |
| VSWR | 1.5:1 maximum | |
| Noise Figure @ Maximum Gain | 5.0 dB | |
| Physical | | |
| Dimensions W x D x H | 21.3 x 15 x 12.3 inches (540 x 382 x 313 mm) | |
| Weight | 73 lbs. (33kg) | |
| Enclosure | Aluminum (NEMA4/IP-66) | |
| RF Connector | N-type, Female | |
| Power | | |
| Power Supply | 36 – 72 VDC | |
| Power Consumption | D-MBR 3707 3708 PS NFPA: | 350W |
| | D-SBR 3707/3708/4008 PS NFPA: | 270W |
| General | | |
| Compliance | IC/FCC | |
| Environmental | | |
| Operating Temperature | -5 to 122° F (-10° C to +50° C) | |
| Humidity | 10% to 90% Condensed | |

⁽¹⁾ Every filter above 10MHz utilize 2 FPGA resources

⁽²⁾ FCC Part 90 is valid ONLY for SMR 700/800 high power Class A booster models supporting up to 10MHz bandwidth as follows: 758 - 775MHz, 788 – 805MHz, 806 - 817MHz, 851 – 862MHz;

⁽³⁾ FCC Part 20 is applied for 800MHz high power Class A Booster models running CMRS services under the following bands: 817 – 824MHz, 862 – 869MHz.

APPENDIX B - ORDERING INFORMATION

| IDENTIFICATION | DESCRIPTION PART | NUMBER |
|---|--|------------------------------------|
| D-MBR 3707-3708 PS with NFPA and Red painted case | Digital Dual Band, Multi Channel Selective Signal Booster Class A. 700/800 MHz 24 filters, 37dBm composite per band, 95dB gain, DC powering with NFPA and IFC compliant Alarm Outputs and red painted case. | D-MBR 3707-3708-PS-NFPA-DC-CLASS-A |
| D-SBR 3707 PS with NFPA and Red painted case | Digital Single Band, Multi Channel Selective Signal Booster Class A. 700 MHz 24 filters, 37dBm composite per band, 95dB gain, DC powering with NFPA and IFC compliant Alarm Outputs and red painted case. | D-SBR 3707-PS-NFPA-DC-CLASS-A |
| D-SBR 3708 PS with NFPA and Red painted case | Digital Single Band Multi Channel Selective Signal Booster Class A. 800 MHz 24 filters, 37dBm composite per band, 95dB gain, DC powering with NFPA and IFC compliant Alarm Outputs and red painted case. | D-SBR 3708-PS-NFPA-DC-CLASS-A |
| D-SBR 4008 PS with NFPA and Red painted case | Digital Single Band Multi Channel Selective Signal Booster Class A. 800 MHz 24 filters, 40dBm composite per band, 95dB gain, DC powering with NFPA and IFC compliant Alarm Outputs and red painted case. | D-SBR 4008-PS-NFPA-DC-CLASS-A |
| AC feeder and battery charger | AC feeder and battery charger for 200AH batteries with NFPA and IFC compliant Alarm Outputs and red painted case. | AC-CHARGER-48V-200AH |