

Peerless® Pinnacle™

Stainless Steel Gas Boilers

WARNING

If the information in this manual is not followed exactly, a fire or explosion may result causing property damage, personal injury or loss of life.

- Do not store or use gasoline or other flammable vapors and liquids in the vicinity of this or any other appliance.
- **WHAT TO DO IF YOU SMELL GAS**
 - Do not try to light any appliance.
 - Do not touch any electrical switch; do not use any phone in your building.
 - Immediately call your gas supplier from a neighbor's phone. Follow the gas supplier's instructions.
 - If you cannot reach your gas supplier, call the fire department.
- Installation and service must be performed by a qualified installer, service agency or the gas supplier.

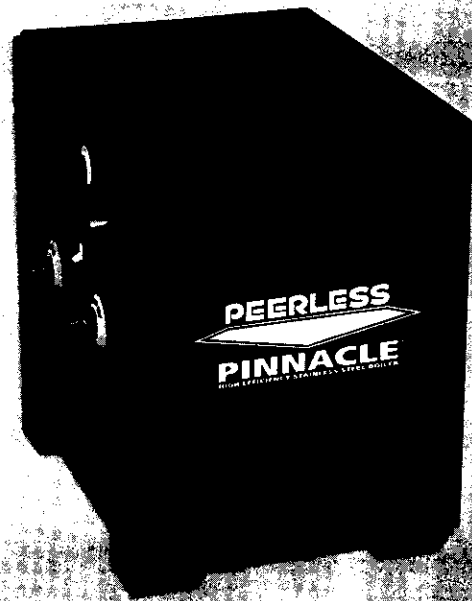

As an ENERGY STAR® Partner, Peerless Heater Company has determined that this product meets the ENERGY STAR® guidelines for energy efficiency.

Installation, Operation & Maintenance Manual



Peerless Heater Company

PEERLESS®

PINNACLE

New
Product!

3 Sizes 27 to 199 MBH Input 92% AFUE

Features:

Three Sizes Available

- PI-80 - 27 to 80 MBH Input Modulation
- PI-140 - 46 to 140 MBH Input Modulation
- PI-199 - 66 to 199 MBH Input Modulation

Fully Modulating Burner for Maximum Efficiency

- 92% AFUE - Energy Star® Efficient

Natural or LP Gas

Direct Vent

- Sealed Combustion
- No Chimney Required - Horizontal or Vertical Venting
- Uses Standard Schedule 40 PVC Plastic Pipe for Venting
- Concentric PVC or V1000 Aluminum Vent Kits Available

Compact, Light-Weight Design

- Installation Flexibility
- Zero Clearance to Combustibles
- Lightweight Design (75 to 111 lbs.) & Small Footprint

Stainless Steel Construction

- High Grade Stainless Steel Burner and Heat Exchanger

Safe Operation

- Honeywell Gas Valve and Venturi System
- State-of-the-Art Control Board with LED Light Indicator
- Spark Ignition

Quiet Operation

- As Quiet as Most Home Appliances

Comprehensive Warranty

- One-Year Parts & Labor Warranty
- Limited, 12-Year Warranty on the Heat Exchanger
- See Below for Warranty Description

Environmentally Friendly

- Low Emissions

A Complete
Warranty Program
Like No Other!

92%
AFUE!



As an ENERGY STAR® Partner, Peerless Heater Company has determined that this product meets the ENERGY STAR® guidelines for energy efficiency.

Standard Equipment:

- Honeywell Gas Valve
- Burner Fan
- High Limit Temperature Control
- 30 PSI Safety Relief Valve
- Combination Temperature-Pressure Gauge
- 3" PVC Screened Air Intake Terminal and Exhaust Terminal

Optional Equipment:

- 3" V1000 Aluminum Outside Vent Termination Kit
- 3" Concentric PVC Vent Termination Kit
- Adjustable Steel Boiler Stand

Peerless Heater Company is pleased to offer one of the most comprehensive warranty programs in the industry. The Peerless Pinnacle, stainless steel boiler carries a full one-year warranty on the entire boiler. Peerless will purchase an additional warranty that covers labor for replacing warranted parts from the 31st day through the first year after installation, provided the warranty registration card is returned. In addition, Peerless offers a limited, pro-rated, 12 year warranty on the heat exchanger of the Pinnacle boiler. Five and ten-year extended warranties on parts and labor may also be purchased. This summary is not a specific warranty. Please consult Peerless Heater Company for complete warranty information.

Peerless Heater Company • 231 North Walnut Street • Boyertown, PA 19512-1021 • 610-367-2153 • www.peerless-heater.com

FAB-PI R1 (11 03 7 5M)
Printed in U.S.A

TABLE OF CONTENTS

| | | | |
|---|-----------|---|-----------|
| USING THIS MANUAL | 1 | E. EXTENDED VENT LENGTHS WITH 4" PIPE | 14 |
| A. INSTALLATION SEQUENCE | 1 | F. CONDENSATE | 14 |
| B. SPECIAL ATTENTION BOXES | 1 | G. BOILER REMOVAL FROM COMMON VENTING SYSTEM | 14 |
| 1. PREINSTALLATION | 2 | 6. ELECTRICAL | 15 |
| A. ACCESSIBILITY CLEARANCES | 2 | A. WIRING | 15 |
| B. CLEARANCE FROM COMBUSTIBLE CONSTRUCTION | 2 | B. ZONED SYSTEM WIRING | 15 |
| C. LIQUEFIED PETROLEUM (LP) GAS | 2 | C. SEQUENCE OF OPERATION | 17 |
| D. INSTALLATION SURVEY | 2 | 7. START-UP PROCEDURES | 18 |
| E. PLANNING THE LAYOUT | 2 | A. COMPLETING THE INSTALLATION | 18 |
| 2. BOILER SET-UP | 3 | B. LIGHTING/OPERATING INSTRUCTIONS | 19 |
| 3. WATER PIPING AND CONTROLS | 4 | C. CONTROL DESCRIPTIONS | 20 |
| A. BOILER SUPPLY, RETURN AND CONTROLS | 4 | D. CHECK-OUT PROCEDURE | 20 |
| B. CIRCULATOR SIZING | 5 | 8. TROUBLESHOOTING | 21 |
| C. SAFETY RELIEF VALVE | 5 | A. SHUT-DOWN | 21 |
| D. PIPING FOR ZONED SYSTEMS | 6 | B. BOILER FAULT CODES | 22 |
| E. EXPANSION TANK | 7 | C. BOILER FAULT CONDITIONS | 22 |
| F. INDIRECT-FIRED WATER HEATER | 7 | 9. MAINTENANCE | 24 |
| G. FREEZE PROTECTION | 7 | A. GENERAL (WITH BOILER IN USE) | 24 |
| 4. GAS PIPING | 8 | B. WEEKLY (WITH BOILER IN USE) | 24 |
| 5. VENTING | 10 | C. ANNUALLY (BEFORE START OF HEATING SEASON) | 24 |
| A. GENERAL | 10 | 10. BOILER DIMENSIONS & RATINGS | 25 |
| B. EXHAUST VENT/AIR INLET VENT LOCATION | 10 | 11. REPAIR PARTS | 27 |
| C. EXHAUST VENT INSTALLATION | 10 | | |
| D. AIR INLET VENT INSTALLATION | 11 | | |

USING THIS MANUAL

A. INSTALLATION SEQUENCE

Follow the installation instructions provided in this manual in the order shown. The order of these instructions has been set in order to provide the installer with a logical sequence of steps that will minimize potential interferences and maximize safety during boiler installation.

B. SPECIAL ATTENTION BOXES

Throughout this manual you will see special attention boxes intended to supplement the instructions and make special notice of potential hazards. These categories mean, in the judgment of Peerless Heater Company:

DANGER

Indicates a condition or hazard which will cause severe personal injury, death or major property damage.

WARNING

Indicates a condition or hazard which may cause severe personal injury, death or major property damage.

CAUTION

Indicates a condition or hazard which will or can cause minor personal injury or property damage.

NOTICE

Indicates special attention is needed, but not directly related to potential personal injury or property damage.

1. PREINSTALLATION

Read carefully, study these instructions before beginning work.

This boiler must be installed by a qualified contractor.

The boiler warranty can be voided if the boiler is not installed, maintained and serviced correctly.

Boiler can be installed at high altitude with no burner adjustments. LP equipped boilers must not be installed at elevations above 7,000 feet.

NOTICE

The equipment must be installed in accordance with those installation requirements of the authority having jurisdiction or, in the absence of such requirements, to the current edition of the *National Fuel Gas Code, ANSI Z223.1/NFPA 54 and/or CAN/CGA B149 Installation Codes*.

Where required by the authority having jurisdiction, the installation must conform to *American Society of Mechanical Engineers Safety Code for Controls and Safety Devices for Automatically Fired Boilers, ANSI/ASME CSD-1*.

A. ACCESSIBILITY CLEARANCES

The following are the recommended minimum accessibility clearances between boiler and adjacent wall or other appliances.

1. 16" from right side or left side of boiler.
2. 15" from top of boiler.
3. 4" from front of boiler.
4. Provide clearance for annual inspection of vent pipe and condensate connections.

B. CLEARANCE FROM COMBUSTIBLE CONSTRUCTION

The design of this boiler is certified for closet installation with the following clearances:

1. 0" from left side, right side, rear, top, bottom, front and combustible construction.
2. 0" from vent pipe and combustible construction.
3. This boiler is design certified for use on combustible floors.

DANGER

Do not install this boiler on carpeting. Boiler installation on carpeting is a fire hazard.

WARNING

Liquefied Petroleum (LP) is heavier than air and may collect or "pool" in a low area in the event of a leak from defective equipment. This gas may then ignite, resulting in a fire or explosion.

C. LIQUEFIED PETROLEUM (LP) GAS

The following LP requirements from the *Uniform Mechanical Code*, section 304.6, may be in effect in your geographic area:

"Liquefied petroleum gas-burning appliances shall not be installed in a pit, basement or similar location where heavier-than-air gas might collect. Appliances so fueled shall not be installed in an above-grade under-floor space or basement unless such location is provided with an approved means for removal of unburned gas."

D. INSTALLATION SURVEY

For new and existing installations, a Water Installation Survey is available from Peerless Heater Company. The survey will provide information on how a hot water boiler works with your specific system and will provide an overview of hot water system operation in general.

You can also use this survey to locate system problems which will have to be corrected. To obtain copies of the Water Installation Survey, contact your Peerless representative.

E. PLANNING THE LAYOUT

Prepare sketches and notes of the layout to minimize the possibility of interferences with new or existing equipment, piping, venting and wiring. Review limitations on vent pipe, vent terminal, and air inlet pipe locations in Section 5, Venting.

WARNING

Boiler is certified as an indoor appliance. Do not install boiler outdoors or locate where it will be exposed to freezing temperatures.

2. BOILER SET-UP

1. Place boiler on a level surface. (Note: An optional boiler stand is available. Contact your Peerless Distributor.)
2. Locate boiler to allow for ease of vent pipe installation and heating system piping.

WARNING

Boiler must be set on a level surface so condensate does not back up inside the boiler.

3. Install boiler in an area with a floor drain or install in a suitable drain pan.

3. WATER PIPING AND CONTROLS

A. BOILER SUPPLY, RETURN AND CONTROLS

1. Size the supply and return to suit the system. Refer to Figure 1. Refer also to the I=B=R Installation Guide No. 2000 and the Peerless Water Survey for additional guidance during water piping installation.
2. The boiler incorporates a pressure switch in the Outlet Manifold. This switch will not let the boiler operate without a minimum of 10 PSI on system.
3. Refer to Figure 1 for suggested controls and components location in the near boiler piping.
4. In older hydronic systems where sediment may exist, install a basket strainer to prevent particles from returning to boiler.
5. Install this boiler so that the gas ignition system components are protected from water (dripping, spraying, etc.) during appliance operation and service (circulator replacement, condensate trap, control replacements, etc.)
6. If this boiler and distribution system is used in conjunction with a refrigeration system, pipe the chilled medium in parallel with the boiler and install the proper valve to prevent the chilled medium from entering the boiler.
7. When the boiler is connected to heating coils located in air handling units where they may be exposed to refrigerated air circulation, install flow control valves or other automatic means to prevent gravity circulation of the boiler water during the cooling cycle.
8. If the boiler is installed above radiation level, provide a low water cutoff device at the time of boiler installation.

⚠ NOTICE

All piping must be properly supported. See Figure 1.

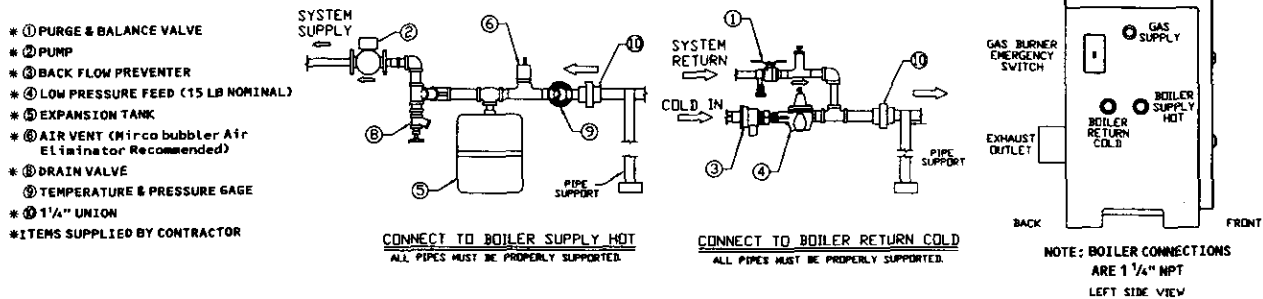

Figure 1: Supply and Return Near Boiler Piping

B. CIRCULATOR SIZING

The boiler heat exchanger does have a pressure drop which must be allowed for in determining circulator sizing. Using the chart in Figure 2, the pressure drop for each boiler model is as follows:

- PI-80 = 8 feet of head at 8 GPM flow rate
- PI-140 = 11 feet of head at 14 GPM flow rate
- PI-199 = 18 feet of head at 19.9 GPM flow rate

Refer to Figure 2 for recommended circulator sizing.

C. SAFETY RELIEF VALVE

The safety relief valve is factory installed into the right side boiler manifold.

⚠ CAUTION

Pipe the discharge of safety relief valve to prevent injury in the event of pressure relief. Pipe the discharge to a drain. Provide piping that is the same size as the safety relief valve outlet.

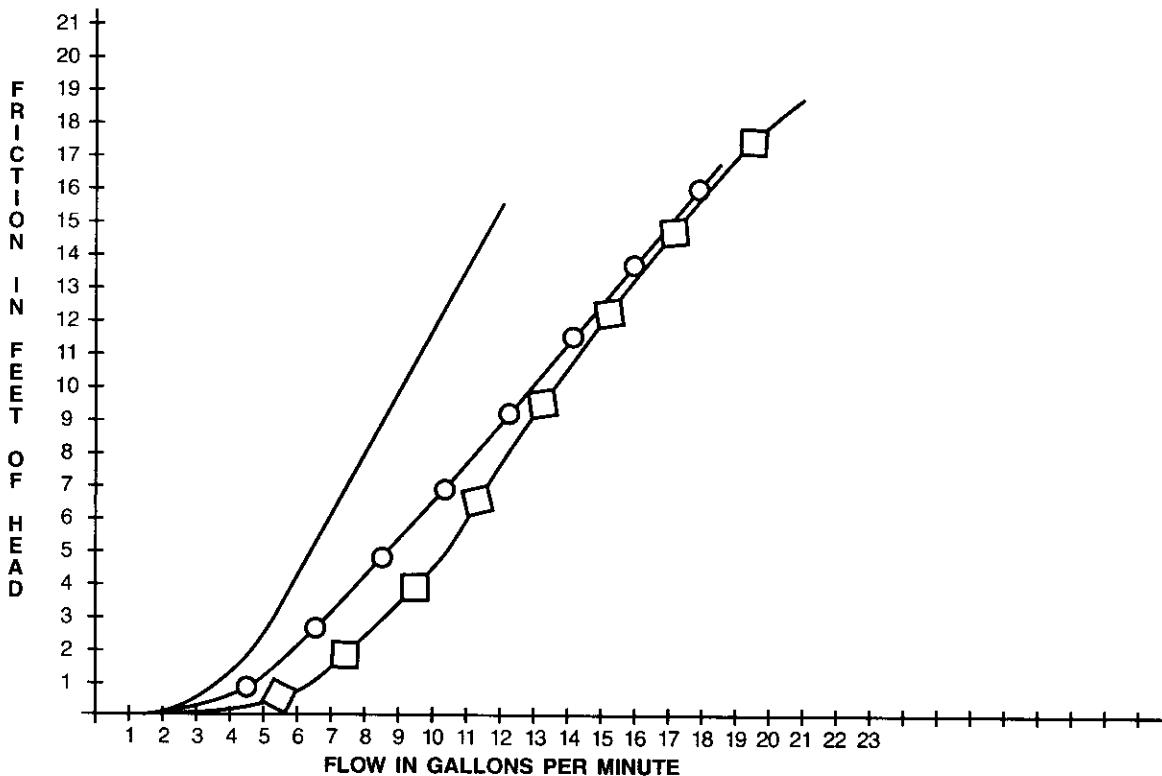

| | TACO P/N | GRUNDFOS P/N |
|--------|----------|---------------|
| PI-80 | 007 (1) | 15-42 F SPD-2 |
| PI-140 | 0010 (1) | 26-64 F |
| PI-199 | 0011 (1) | 26-96 F |

1) THE RECOMMENDED CIRCULATORS ARE BASED ON 1 GPM PER 10,000 BTU/HR W/20° Δt

Figure 2: Circulator Sizing

D. PIPING FOR ZONED SYSTEMS

1. See Figures 3 and 4 for basic zoned system layouts.
2. If required, provide means to isolate and drain each zone separately.

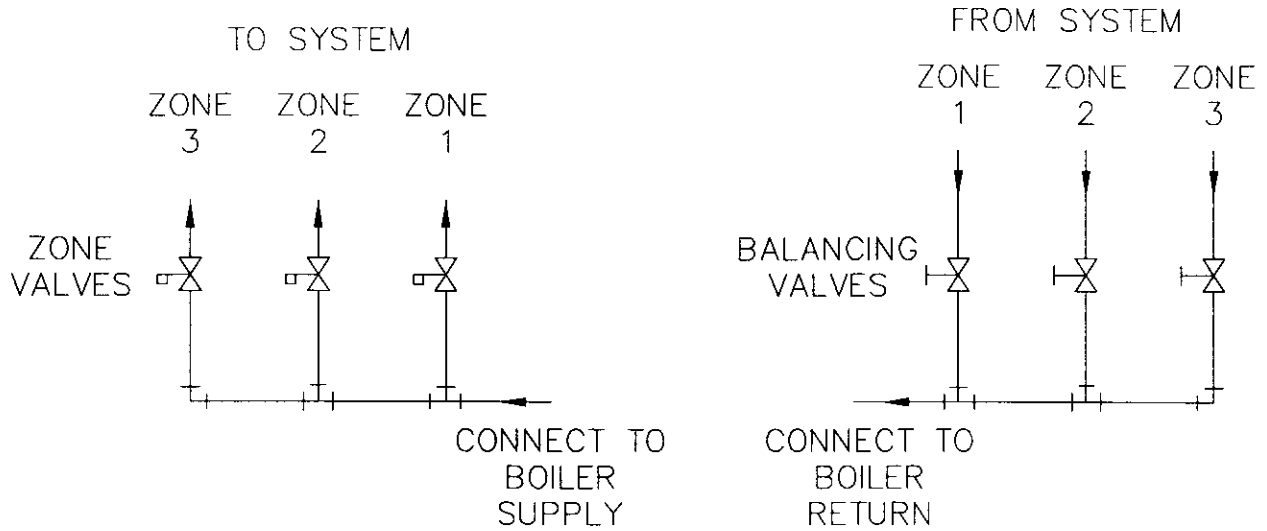

Figure 3: Zone Piping with Zone Valves

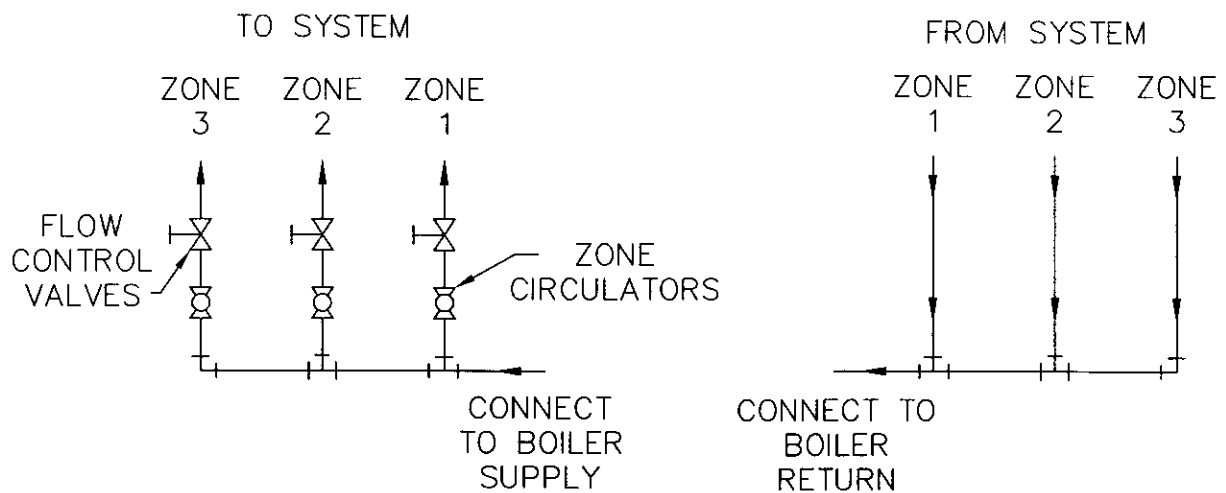

Figure 4: Zone Piping with Circulators

E. EXPANSION TANK

1. Consult the tank manufacturer's instructions for specific information relating to tank installation. Size the expansion tank for the required system volume and capacity.
2. Expansion tanks are available with built-in fill valves and check valves for reducing supply water pressure and maintaining minimum system pressure. Check the design features of the tank and provide valves as necessary. Boiler system requires 12 PSI minimum.

Refer back to Figure 1 for typical expansion tank piping.

F. INDIRECT-FIRED WATER HEATER

If the boiler is to be used in conjunction with an indirect-fired water heater, refer to Figure 4 for typical piping. Follow the instructions provided by the water heater manufacturer. Pipe the water heater as a separate zone.

G. FREEZE PROTECTION

For new or existing systems that must be freeze-protected:

⚠ WARNING

Use only inhibited propylene glycol solutions of up to 50% by volume with water. Ethylene glycol is toxic and can attack gaskets and seals used in hydronic systems.

1. Glycol in hydronic applications is specially formulated for this purpose. It includes inhibitors which prevent the glycol from attacking metallic system components. Make certain that the system fluid is checked for the correct glycol concentration and inhibitor level.
2. The antifreeze solution should be tested at least once a year and as recommended by the antifreeze manufacturer.
3. Antifreeze solutions expand more than water. For example, a 50% by volume solution expands 4.8% in volume for a temperature increase from 32° F to 180° F, while water expands 3% with the same temperature rise. Allowance must be made for this expansion in system design.
4. For more information, consult the Peerless Water Installation Survey and the antifreeze manufacturer.

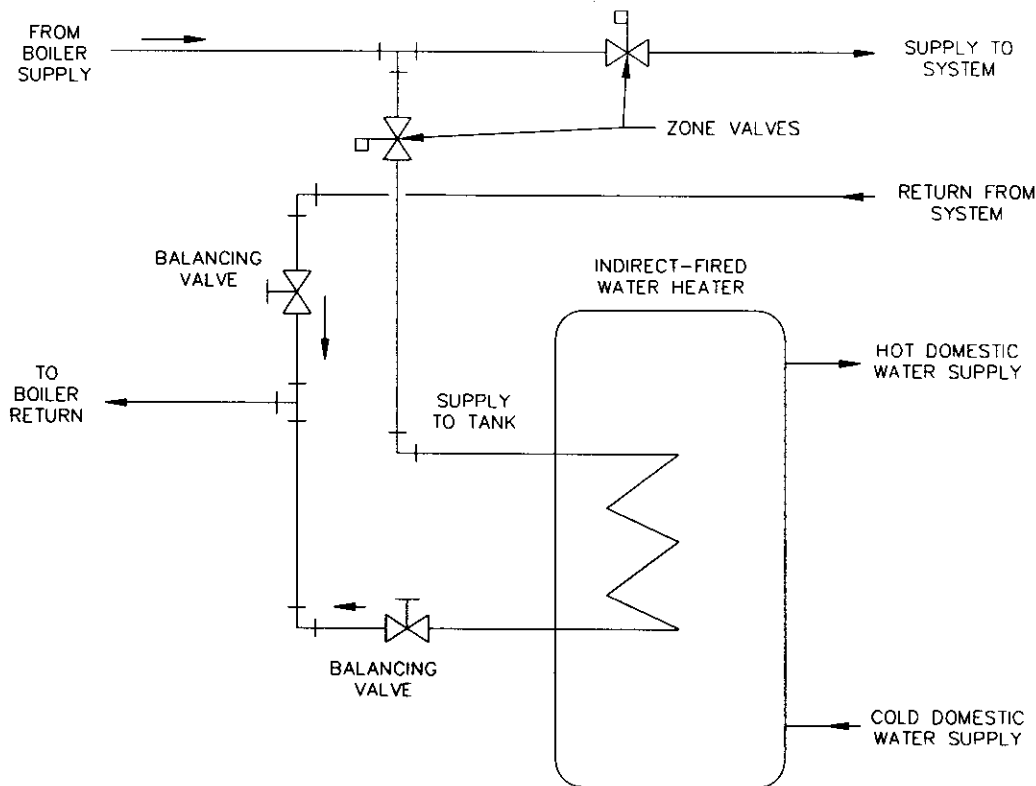

Figure 5: Typical Piping with Indirect-Fired Water Heater

4. GAS PIPING

1. Size and install the gas supply piping properly in order to provide a supply of gas sufficient to meet the maximum demand without exceeding a pressure drop greater than .5" W.C. between the meter and the boiler.
2. Determine the volume of gas to be provided to the boiler in cubic feet per hour. To obtain this value, divide the Btu per hour rating (on the boiler rating label) by the heating value of the gas in Btu per cubic feet. Obtain the heating value of the gas from the gas supplier. As an alternative, use Table 1 or 2 on the next page to obtain the volume of gas to be provided to the boiler.
3. Use the value obtained above as the basis for piping sizing. Size the gas piping in accordance with Table 3 for natural gas. Consult the *National Fuel Gas Code ANSI Z223.5/NFPA 54 and/or CAN/CGA B149* for other sizing options and LP gas pipe sizes.
4. Locate the drop pipe adjacent to, but not in front of the boiler.
5. Install a sediment trap. See Figure 6. Locate a tee in the drop pipe at same elevation as the gas inlet connection to the boiler. Extend the drop pipe to a pipe cap.
6. Install a ground joint union ahead of the gas control assembly to permit servicing of the control. Install a service valve as shown in Figure 6.

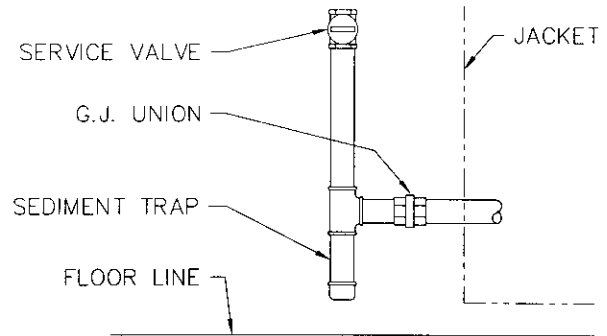

Figure 6: Gas Connection to Boiler

9. Disconnect the boiler and its individual shut-off valve from the gas supply piping system during any pressure testing of that system at test pressure in excess of 1/2 psig (3.5 kPa). Remove the mounting screws of the flanged gas connection on the gas valve, and disconnect flange from valve.

⚠ WARNING

Use a pipe joint sealing compound that is resistant to the action of liquefied petroleum gas. A non-resistant compound may lose sealing ability in the presence of this gas, resulting in a gas leak and fire or explosion potential.

7. Check piping for leaks prior to placing the boiler in operation.
Use an approved gas detector, a non-corrosive leak detection fluid or other leak detection method. If leaks are found, turn off all gas flow and repair as necessary.

⚠ WARNING

When checking for leaks, do not use matches, candles, open flames or other methods that provide a source of ignition. This can ignite a gas leak, resulting in fire or explosion.

8. The gas piping connection to the boiler must be a minimum of 3/4 pipe size. Boiler is provided with a 3/4 x 1/2 pipe reducer. Do not remove the reducer.

⚠ CAUTION

Do not subject the gas valve to more than 1/2 psi pressure. Doing so may damage the valve.

Isolate the boiler from the gas supply piping system by closing its individual service valve during any pressure testing of the gas supply piping system at test pressure equal to or less than 1/2 psig (3.5 kPa).

10. Check for proper supply pressures to boiler at sediment trap location. Remove pipe cap and provide fittings as required. Minimum permissible supply pressure (Inches Water Column):

| | |
|-------------|------|
| Natural Gas | 3.7" |
| LP Gas | 3.7" |

Maximum permissible supply pressure to the boiler (Inches Water Column):

| | |
|-------------|-------|
| Natural Gas | 13.5" |
| LP Gas | 13.5" |
11. Maintain a minimum distance of 10 feet between a gas pressure regulator and boiler.
12. Gas line must be properly purged of air to allow for normal main burner ignition.

Table 1: Natural Gas

| Model | Input (Cubic Ft/Hr) |
|--------|------------------------|
| PI-80 | 80 |
| PI-140 | 140 |
| PI-199 | 199 |

Based on 1000 Btu/Cubic Ft.

Table 2: LP Gas

| Model | Input (Cubic Ft/Hr) |
|--------|------------------------|
| PI-80 | 32 |
| PI-140 | 56 |
| PI-199 | 79 |

Based on 2500 Btu/Cubic Ft.

Table 3: Pipe Capacity

Capacity of pipe of different diameters and lengths in cu. ft. per hour with pressure drop of 0.3 in. and specific gravity of 0.60. No allowance for an ordinary number of fittings is required.

| Pipe Length Feet | ¾" Pipe | 1" Pipe | 1¼" Pipe | 1½" Pipe |
|------------------|---------|---------|----------|----------|
| 10 | 278 | 520 | 1,050 | 1,600 |
| 20 | 190 | 350 | 730 | 1,100 |
| 30 | 152 | 285 | 590 | 890 |
| 40 | 130 | 245 | 500 | 760 |
| 50 | 115 | 215 | 440 | 670 |
| 60 | 105 | 195 | 400 | 610 |

Multipliers to be used with the above table when the specific gravity of the gas is other than 0.60:

| | | | | | |
|------------------|------------|------|------|-------|-------|
| Specific Gravity | ... 0.5 | 0.55 | 0.60 | 0.65 | 0.70 |
| Multiplier | 1.10 | 1.04 | 1.00 | 0.962 | 0.926 |

5. VENTING

A. GENERAL

1. Install vent system in accordance with these instructions and with Part 7, Venting of Equipment, *National Fuel Gas Code, ANSI Z223.1/NFPA 54, CAN/CGA B149*, or applicable provisions of the local building codes.
2. Boiler is a direct vent appliance. The boiler vent is listed as Category IV.

WARNING

This vent system will operate with a positive pressure in the vent pipe. Do not connect vent connectors serving appliances vented by natural draft into any portion of mechanical draft systems operating under positive pressure.

B. EXHAUST VENT/AIR INLET VENT LOCATION

NOTICE

Flue gases will condense as they exit the vent termination. This condensate can freeze on exterior building surfaces which may cause discoloration of these surfaces.

1. Determine exhaust vent location.
 - a. Vent is approved for 0" clearance to combustible construction.
 - b. Provide 3 feet clearance above any forced air inlet within 10 feet.
 - c. Provide 1 foot clearance below, 1 foot beside, or 1 foot above any door, window, or gravity air inlet into any building.
 - d. Provide 1 foot clearance between bottom of vent terminal and ground level and normal snow lines.
 - e. Provide 4 feet horizontal clearance from, and in no case above or below, unless a 4 foot horizontal distance is maintained, from electric meters, gas meters, regulators and relief equipment.
 - f. Do not locate vent terminal over public walkways where condensate could create a nuisance or hazard.
 - g. When adjacent to a public walkway, locate vent terminal at least 7 feet above grade.
 - h. Do not locate directly under roof overhangs to prevent icicles from forming.
 - i. Provide 3 foot clearance from inside corner of adjacent walls.
2. Determine air inlet vent location.
 - a. Provide 1 foot clearance between bottom of vent and ground level and normal snow lines.
3. Refer to venting diagrams (Figures 7 through 12) for typical sidewall and vertical vent/air inlet piping.
 - a. Maintain distances between air inlet, vent, and exhaust vent as indicated in Figures 7, 8, and 11. Do not space the air inlet vent and exhaust vent greater than 6 feet apart.
 - b. When sidewall venting multiple 3" concentric vent kits, the vent kits must remain in a horizontal plane and placed no closer than 8" center to center. Also refer to instructions provided with vent kit.
 - c. When sidewall venting multiple V1000 vent kits refer to instructions provided with vent kit.

C. EXHAUST VENT INSTALLATION

1. For minimum and maximum vent pipe lengths refer to Table 4.
2. Use only 3" PVC, CPVC, or ABS solid schedule 40 or 80 material for exhaust vent. 4" PVC, CPVC, or ABS solid schedule 40 or 80 pipe is also approved under special conditions; see Section E, Extended Vent Lengths with 4" Pipe, in this section for details. FOAM CORE PIPING IS NOT APPROVED.
3. Vent connection is located on rear of boiler and is marked "exhaust outlet".
4. All joints must be properly cleaned, primed, and cemented. Use only approved cement and primer for PVC, CPVC and ABS materials. Cement must conform to ASTM D-2564 (PVC) or D2235 (ABS).
5. Remove all burrs and debris from joints and fittings.
6. Horizontal lengths must slope back to boiler connection not less than 1/4" per foot to allow condensate to flow back to boiler.
7. A screened 3" straight coupling is provided with boiler for use as a vent termination. Optional vent terminations approved for use with the Pinnacle boiler are 3" concentric KGAVT0601CVT Vent Kit and V1000 Vent Kit. Both are available from a Peerless Distributor.
8. Vent piping must be supported at 4 ft. intervals to prevent sagging. The boiler is not intended as a support means for vent.

D . AIR INLET VENT INSTALLATION

1. For minimum and maximum pipe length refer to Table 4.
2. Use same material as noted in Section C for exhaust vent.
3. Air inlet pipe connections is located in the rear of boiler and is marked "air inlet". Connection is a slip fit. No sealant is required.
4. All joints and fittings are to be assembled as per instructions for vent pipe in Section C.
5. A screened inlet air tee is provided with boiler, to be used as an outside termination.
6. Provide same suport means as noted for exhaust vent in Section C.

Table 4: Minimum/Maximum Vent Length

| Boiler Model | Total Combined **Equivalent Length of 3" Exhaust Vent Plus 3" Air Inlet Vent | |
|--------------|---|------------------------|
| | *Minimum Length | *Maximum Length |
| All | 16 feet | 85 feet |

*Lengths are the combined added lengths of the exhaust vent and air inlet vent.

**Include equivalent length of fittings as follows:

- 3" 90 degree elbow = 5 equivalent feet
- 3" 45 degree elbow = 3 equivalent feet
- 3" concentric vent kit = 3 equivalent feet
- 3" air inlet tee = 0 feet
- 3" V1000 vent kit = 0 feet

Refer to Venting Diagram Figures 7 through 12 for Sidewall and Vertical Venting arangements.

DIAGRAMS FOR SIDEWALL VENTING

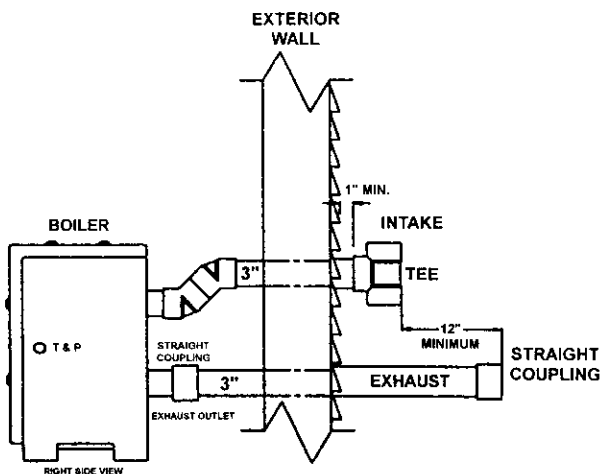

****IMPORTANT NOTE:** All vent pipes must be glued, properly supported, and the exhaust must be pitched minimum of a 1/4" per foot back to the boiler (to allow drainage of condensate).

Figure 7: 3" Sidewall Vent with Tee (Intake) & Coupling (Exhaust)

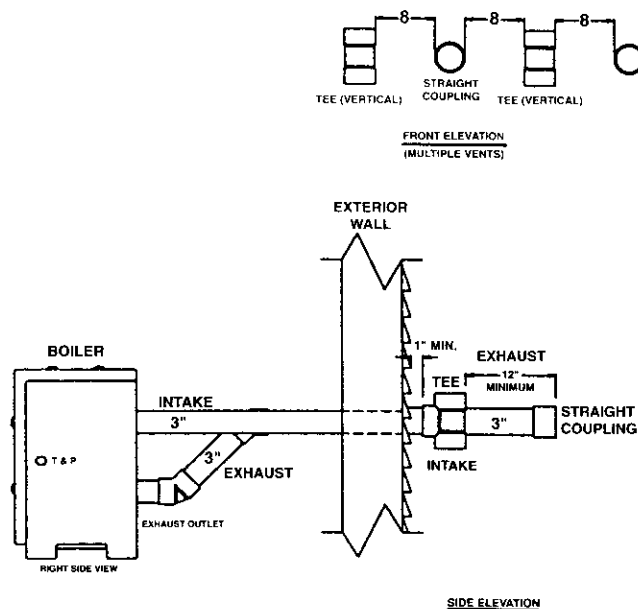

****IMPORTANT NOTE:** All vent pipes must be glued, properly supported, and the exhaust must be pitched minimum of a 1/4" per foot back to the boiler (to allow drainage of condensate).

Figure 8: 3" Sidewall Vent with Tee (Intake) & Coupling (Exhaust)

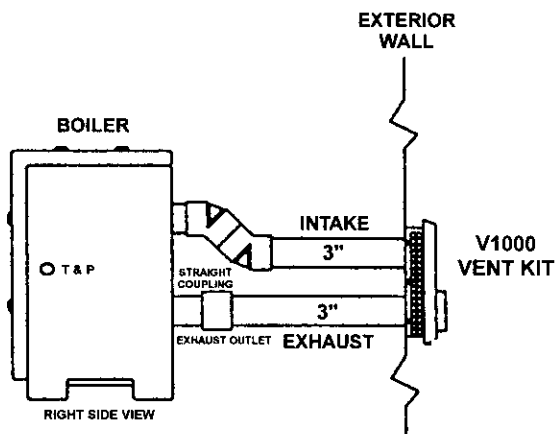

****IMPORTANT NOTE:** All vent pipes must be glued, properly supported, and the exhaust must be pitched minimum of a 1/4" per foot back to the boiler (to allow drainage of condensate).

Figure 9: 3" Sidewall Vent with V1000 Kit

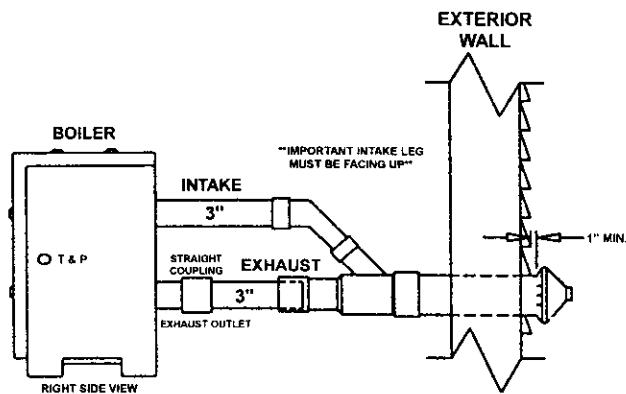

****IMPORTANT NOTE:** All vent pipes must be glued, properly supported, and the exhaust must be pitched minimum of a 1/4" per foot back to the boiler (to allow drainage of condensate).

Figure 10: 3" Sidewall Vent with 3" Concentric Vent Kit (KGAVT0601CVT)

DIAGRAMS FOR VERTICAL VENTING

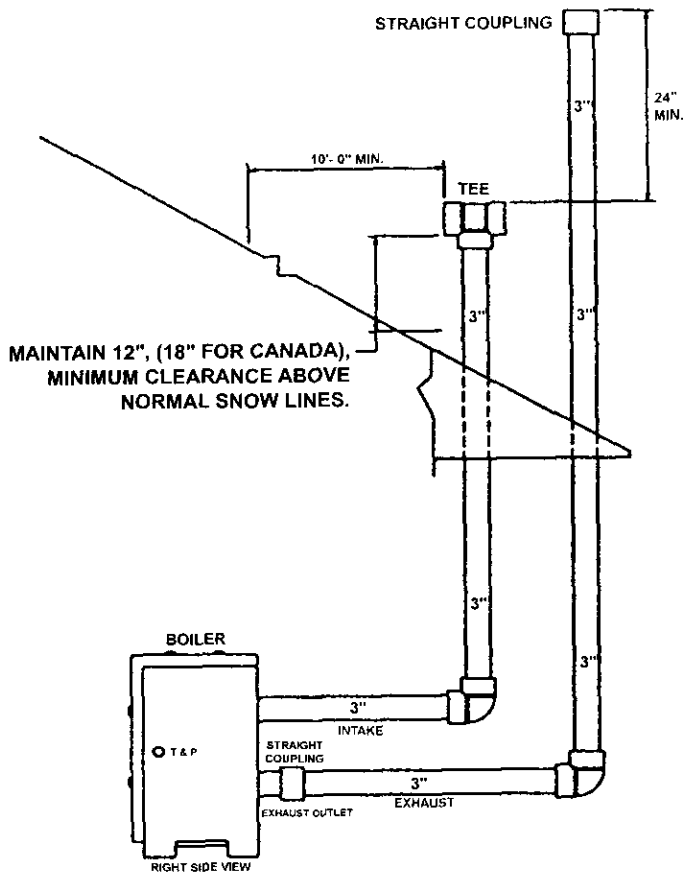

****IMPORTANT NOTE:** All vent pipes must be glued, properly supported, and the exhaust must be pitched minimum of a 1/4" per foot back to the boiler (to allow drainage of condensate).

Figure 11: 3" Roof Vent with Tee (Intake) & Coupling (Exhaust)

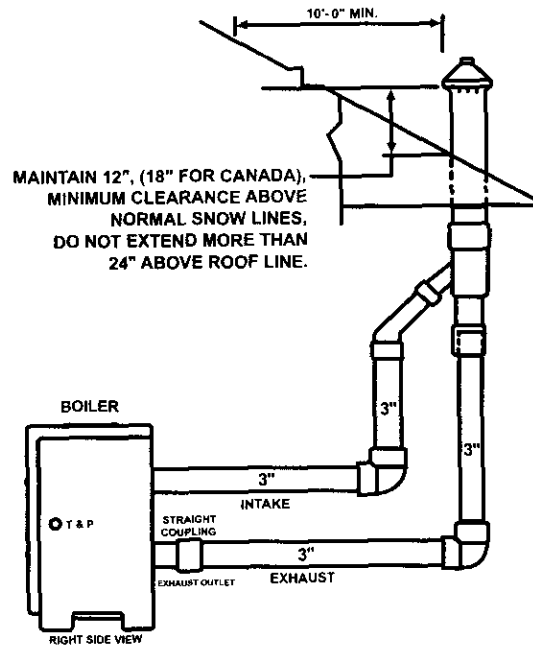

****IMPORTANT NOTE:** All vent pipes must be glued, properly supported, and the exhaust must be pitched minimum of a 1/4" per foot back to the boiler (to allow drainage of condensate).

Figure 12: 3" Roof Vent with 3" Concentric Vent Kit (KGAVT0601CVT)

E. EXTENDED VENT LENGTHS WITH 4" PIPE

1. The connection of air inlet vent and exhaust vent at boiler must remain 3" and each vent must extend from boiler a minimum of 15 equivalent feet before transitioning to 4" vent.
2. The maximum length shown in Table 4 can be increased by using 4" PVC, CPVC, or ABS solid schedule 40 or 80 pipe.
3. Use a 4" x 3" reducing coupling to transition to 4" vent.
4. The maximum combined *equivalent length of 4" air inlet vent plus 4" exhaust vent must not exceed 125 feet.
 - * Equivalent Length of 4" Piping:
 - 4" 90 degree elbow = 3 feet
 - 4" 45 degree elbow = 1 foot
 - 4" air inlet tee = 0 feet
5. Use the same pipe sizes for air inlet vent and exhaust vent.
6. To use the V1000 Vent Kit or 3" Concentric Vent Kit transition 4" pipe to 3" pipe at exit point of building.

F. CONDENSATE

1. This boiler is a high efficiency unit that produces condensate.
2. The rear of the boiler has a plastic hose for connection of a 5/8" size plastic tubing.
3. Slope condensate tubing down and away from boiler into a drain pan or condensate neutralizing filter. Condensate has a low PH level; check with local codes or ordinances before connecting to drain.
4. Do not expose condensate line to freezing temperature.
5. Use only plastic tubing as a condensate drain line.
6. To allow for proper drainage on large horizontal runs, a second line vent may be required and tubing size may need to increase to 1".
7. A condensate removal pump is required if boiler is below drain.

G. BOILER REMOVAL FROM COMMON VENTING SYSTEM

At the time of removal of an existing boiler, follow these steps with each appliance remaining connected to the common venting system placed in operation. While the other appliances remaining connected to the common venting system are not in operation:

- a. Seal any unused openings in the common venting system.
- b. Visually inspect the venting system for proper size and horizontal pitch and determine there is no blockage or restriction, leakage, corrosion and other deficiencies which could cause an unsafe condition.
- c. Insofar as is practical, close all building doors and windows and all doors between the space in which the appliances remaining connected to the common venting system are located and other spaces of the building. Turn on any clothes dryers and any appliance not connected to common venting system. Turn on any exhaust fans, such as range hoods and bathroom exhausts, so they will operate at maximum speed. Do not operate a summer exhaust fan. Close fireplace dampers.
- d. Place in operation the appliance being inspected. Follow the lighting instructions. Adjust thermostat so appliance will operate continuously.
- e. Test for spillage at the draft hood relief opening after 5 minutes of main burner operation. Use the flame of a match or candle, or smoke from a cigarette, cigar, or pipe.
- f. After it has been determined that each appliance remaining connected to the common venting system properly vents when tested as outlined above, return doors, windows, exhaust fans, fireplace dampers and any other gas-burning appliance to their previous conditions of use.
- g. Any improper operation of the common venting system should be corrected so that the installation conforms with the *National Fuel Gas Code, ANSI Z223.1/NFPA 54 and/or CAN/CGA B149*. When resizing any portion of the common venting system, the common venting system should be resized to approach minimum size as determined using the appropriate tables located in the Chapter "Sizing of Category I Venting Systems" of the *National Fuel Gas Code, ANSI Z223.1/NFPA 54*.

6. ELECTRICAL

Install all electrical wiring in accordance with the *National Electrical Code* and local requirements.

⚠ NOTICE

This unit when installed must be electrically grounded in accordance with the requirements of the authority having jurisdiction or, in the absence of such requirements, with the current edition of the *National Electrical Code, ANSI/NFPA 70*.

A. WIRING

1. Refer to Figures 13 and 14 for power supply connection to boiler. Use #14 AWG size wire.
2. Connect boiler to a separate, permanently live electrical supply line with a fused switch. 120 volts, 60 HZ, 15 amp service.
3. The boiler electrical connection is located on the left side of unit.
4. The boiler is supplied with a burner service switch. When referring to Figures 13 and 14, wire the burner service switch in the (HOT) line to boiler.
5. Wires in the electrical J Box have been labeled at the factory. Do not remove labels.
6. Connect the supply line (HOT) wire to the black wire and supply line (GROUND) to the white wire. Boiler control board is polarity sensitive. If polarity is reversed, boiler control will not sense main burner flame.
7. Connect building service ground (green wire), and boiler ground (green wire) to green ground screw located in boiler J Box.

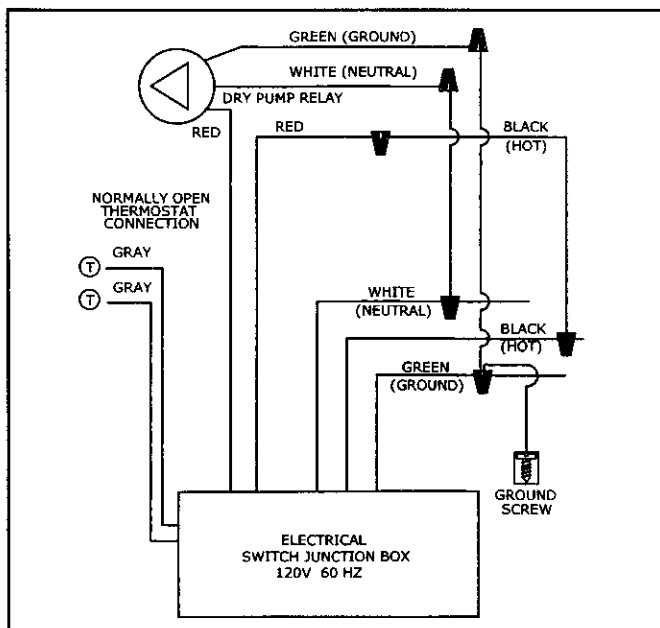

Figure 13: Connection Wiring with Circulator Relay

⚠ NOTICE

The Building System Ground must be inspected by a qualified Electrician.

8. For connection to system circulator and room thermostat refer to Figures 13 and 14. Thermostat anticipator setting is 0.56 amp.
9. The boiler control board and factory wiring are shown in Figure 17.

B. ZONED SYSTEM WIRING

See Figure 15 for typical wiring with zone valves. See Figure 16 for typical wiring with zone circulators. When wiring a zoned heating system, follow all applicable codes, ordinances and regulations.

⚠ NOTICE

Do not power zone valves directly from the boiler transformer. Doing so will greatly reduce the life of the transformer. Use a separate transformer sized to handle the total of all zone valve electrical loads.

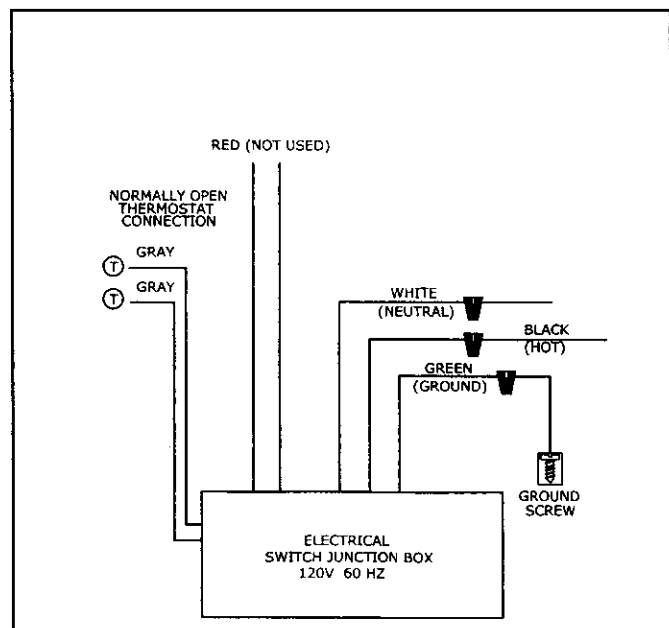

Figure 14: Connection Wiring without Circulator Relay

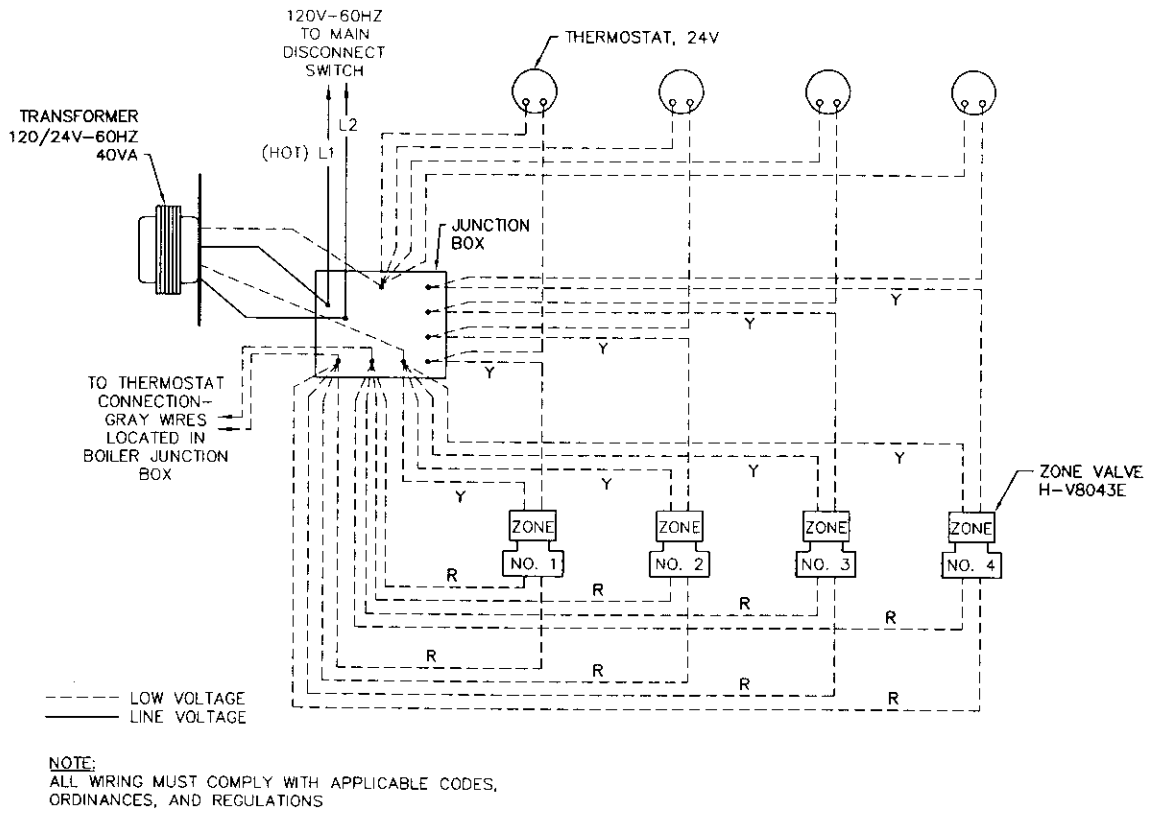

Figure 15: Zone Wiring with Zone Valves

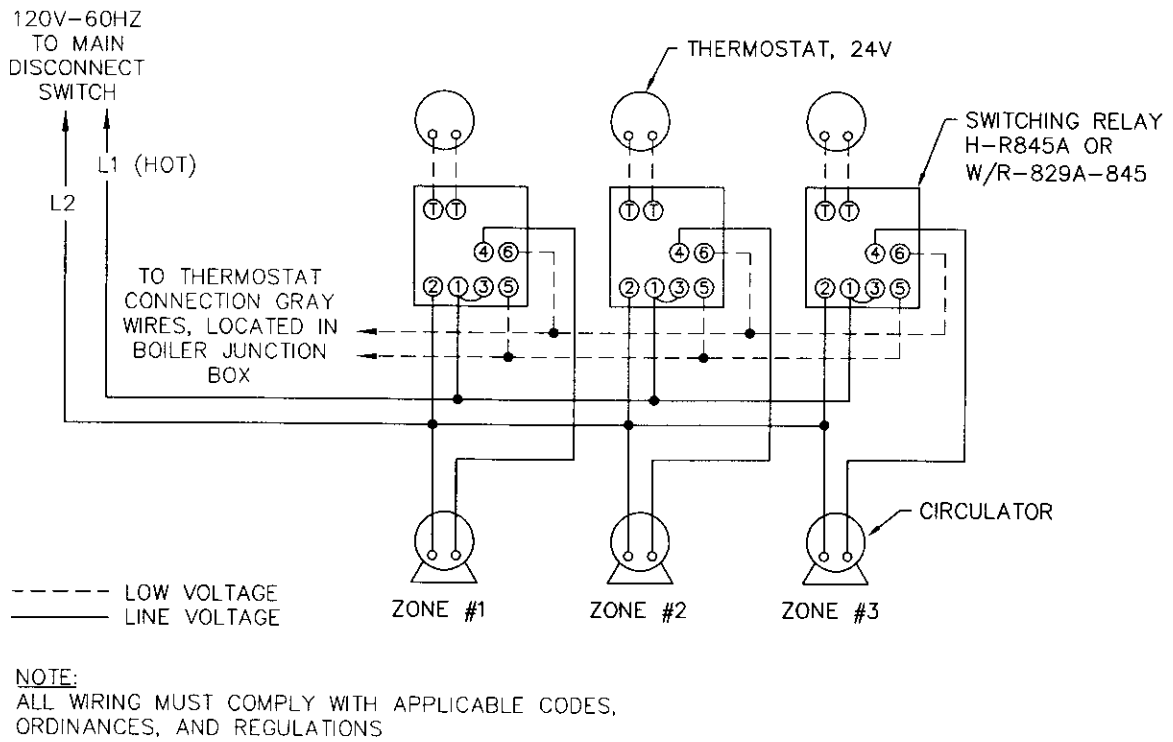

Figure 16: Zone Wiring with Circulators

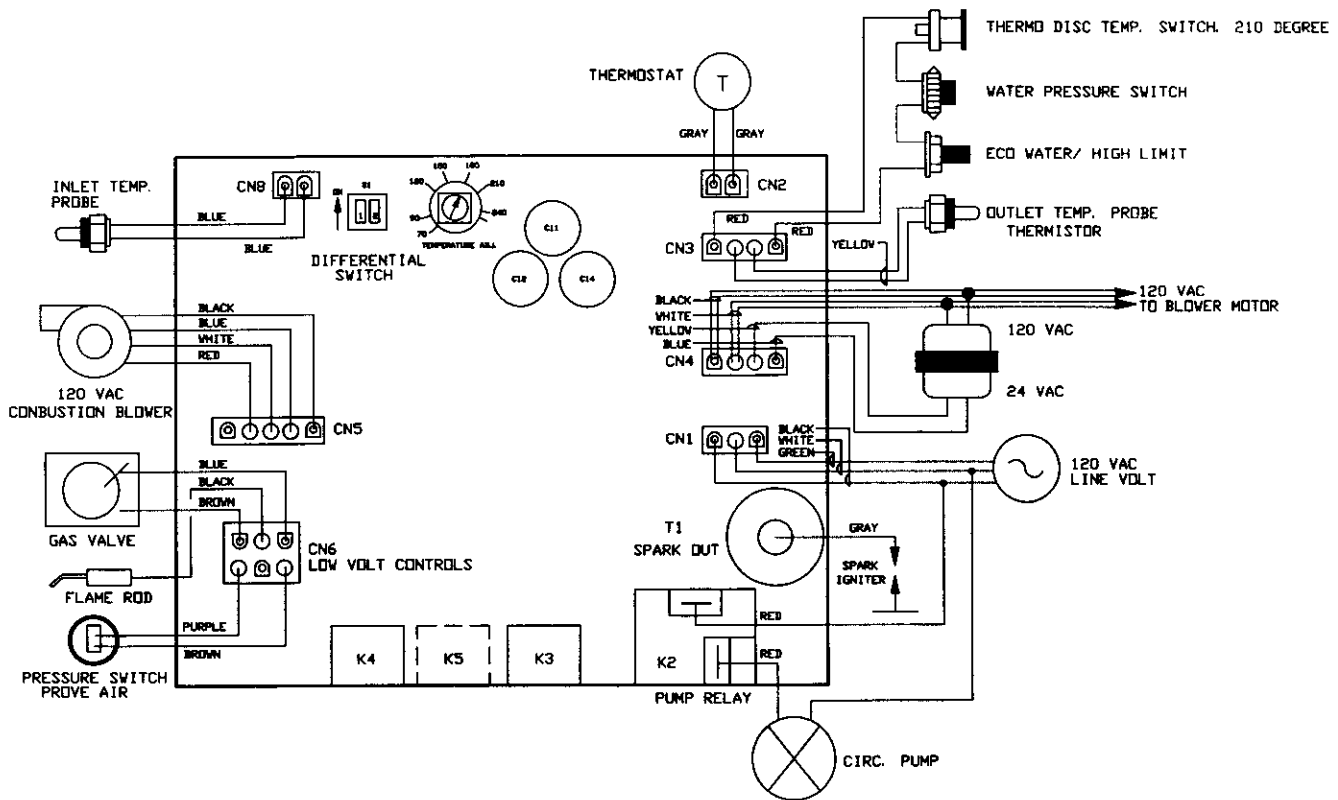

Figure 17: Boiler Control Board Factory Wiring

C. SEQUENCE OF OPERATION

- When power is first applied to the control, the control will initially run through a self-diagnostic routine, and then go into its operating mode. The green LED light will pulse in a dim to bright sequence indicating a normal operating mode. If there is no call for heat, the control will go into the idle state.
 - If the thermostat is calling for heat, the control will apply power to the circulator pump. If the control determines the appliance water temperature is below the temperature dial set point value less the switching differential, the control will initiate a heating cycle.
 - The control then performs selected system diagnostic checks. If all checks are successfully passed, a 5 second pre-purge cycle is initiated (blower on max speed).
 - When the pre-purge period is complete, power is applied to the spark ignitor for a 6 second trial for ignition. If a flame is not verified during the trial-for-ignition, the gas valve is immediately closed, and the control will return to step 2. If after three trials a flame is not verified, the control will go into lockout mode. If a flame is confirmed, the control enters the heating mode.
 - When water temperature reaches the temperature dial set point plus 10° F (or if the thermostat call-for-heat is satisfied), the gas valve is closed and the control enters a 4 second post-purge (blower on max speed). **NOTE: IF THE THERMOSTAT IS STILL CALLING FOR HEAT, THE CIRCULATOR PUMP WILL CONTINUE TO RUN UNTIL THE THERMOSTAT CALL FOR HEAT IS SATISFIED.**
 - When post-purge is complete, the control enters the idle state while continuing to monitor temperature and the state of other system devices. If a call-for-heat is received, the control will automatically return to step 2 and repeat the entire operating cycle.
- During the idle state and heat state, if the control detects an improper operating condition for external devices such as the high-limit switch, the green LED on the control will flash an error code sequence.
- During the call for heat the boiler control board will continually monitor the return and supply water temps in relation to the temperature dial set point and the differential switch setting. The control board will use this input to modulate the blower speed. The blower coupled with the gas valve venturi system will modulate the premix air/gas input to the burner. The gas valve and venturi system provide the optimum gas/air ratio through the full burner modulation.

7. START-UP PROCEDURES

A. COMPLETING THE INSTALLATION

1. Confirm that all water, gas and electricity are turned off.
2. Verify that water piping, venting, gas piping and electrical wiring and components are installed properly. Refer back to previous sections of these instructions as well as equipment manufacturer's instructions as necessary.
3. Fill the boiler and system with water, making certain to vent all air from all points in the system. To check water level in the system, open and close each vent in the system. Water should exit from each vent when it is opened.
4. The pressure reducing valve on the fill line will typically allow the system to be filled and pressurized to 12 PSI. Consult the valve and expansion tank manufacturer for more specific information.
5. Check joints and fittings throughout the system for leaks. If leaks are found, drain the system and repair as required.
6. Connect a manometer at the sediment trap location. Refer to Figure 6. Remove pipe cap and provide fittings as required.
7. Confirm that the gas supply pressure to the boiler is above the minimum and below the maximum values for the gas being used. See the end of Section 4 for these values. If a supply pressure check is required, isolate the boiler and gas valve before performing the pressure check. If the supply pressure is too high or too low, contact the gas supplier.
8. Adjust set point temperature and differential settings as follows:
 - a. Temperature Adjustment: A potentiometer located on the control board is used to adjust the set point temperature on the boiler appliance. This can be set between 70 and 210 degrees.
 - b. Temperature Differential Adjustment: A "DIP" switch is located on the control board. Depending upon the configuration of the "DIP" switch, the differential selection is 6, 12, 20, or 30. See the figure below for further detail.

NOTE: the differential adjustment is the value below the set point, when the burner will fire. (Example: 190 degrees set point, 30 degrees differential, burner will not fire until return water drops below 160 degrees and will modulate the flame until 200 degrees is reached, then post purge and idle state will be achieved. If at any point TT is satisfied, the cycle will be interrupted by post purge and idle state.

9. Turn on electricity and gas to boiler. Check to see if LED light is illuminated on control board.
10. Light the boiler by following the Lighting/Operating Instructions in this section. The initial ignition may require several tries as the piping is purged of air.
11. Use the sequence of operation description and Figure 17 in Section 6 (Electrical) to follow light-off and shutdown sequences and to assist in diagnosing problems. If the boiler does not function properly, consult Section 8, Troubleshooting.

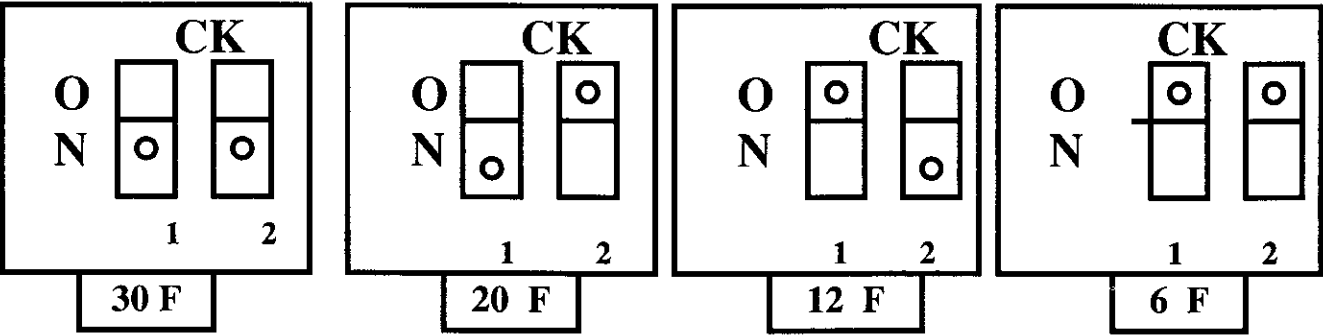

Differential DIP Switch Adjustments

B. LIGHTING/OPERATING INSTRUCTIONS

FOR YOUR SAFETY READ BEFORE OPERATING

WARNING: If you do not follow these instructions exactly, a fire or explosion may result, causing property damage, personal injury or loss of life.

- A. This appliance does not have a pilot. It is equipped with an ignition device which automatically lights the burner. Do not try to light the burner by hand.
 - If you cannot reach your gas supplier, call the fire department.
 - B. BEFORE OPERATING smell all around the appliance area for gas. Be sure to smell next to the floor because some gas is heavier than air and will settle on the floor.
 - C. Use only your hand to turn the gas control knob. Never use tools. If the handle will not turn by hand, don't try to repair it, call a qualified service technician. Force or attempted repair may result in a fire or explosion.
 - D. Do not use this appliance if any part has been under water. Immediately call a qualified service technician to inspect the appliance and to replace any part of the control system and any gas control which has been under water.
- WHAT TO DO IF YOU SMELL GAS**
- Do not try to light any appliance.
 - Do not touch any electric switch; do not use any phone in your building.
 - Immediately call your gas supplier from a neighbor's phone. Follow the gas suppliers' instructions.

OPERATING INSTRUCTIONS

1. STOP! Read the safety information above.
2. Set the thermostat to lowest setting.
3. Turn off all electric power to the appliance.
4. This appliance is equipped with an ignition device which automatically lights the burner. Do not try to light the burner by hand.
5. Remove front cover.
6. Turn gas shutoff valve clockwise to "off". Handle will be vertical, do not force.
7. Wait five (5) minutes to clear out any gas. If you then smell gas, STOP! Follow "B" in the safety information above on this label. If you don't smell gas, go to next step.
8. Turn gas shutoff valve counterclockwise to "on". Handle will be horizontal
9. Install Front Cover.
10. Turn on all electric power to appliance.
11. Set thermostat to desired setting.
12. If the appliance will not operate, follow the instructions "To Turn Off Gas To Appliance" and call your service technician or gas supplier.

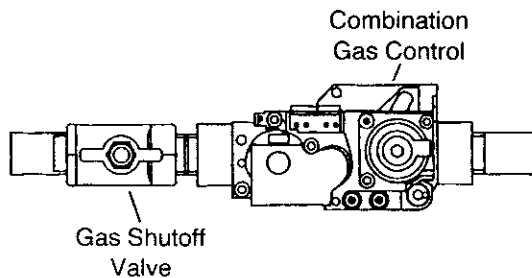

TO TURN OFF GAS TO APPLIANCE

1. Set the thermostat to lowest setting.
2. Turn off all electric power to the appliance if service is to be performed.
3. Remove front cover.
4. Turn gas shutoff valve clockwise to "off". Handle will be vertical. Do not force.
5. Install front cover.

C. CONTROL DESCRIPTIONS

See Figure 19 for location of these devices.

1. **SUPPLY WATER TEMPERATURE THERMISTOR** – Senses supply water temperature from boiler. Shuts down main burner gas upon reaching 10 degrees over control board set point. As supply temperature falls, boiler ignition will restart.
 2. **RETURN WATER TEMPERATURE THERMISTOR** – Senses return water temperature from system. As thermistor senses a drop in return water temperature below the control board set point minus the differential set point, boiler ignition sequence begins.
 3. **WATER HIGH LIMIT SWITCH** – Senses supply water temperature and shuts down main burner gas upon reaching limit set point. Boiler control will go into lockout mode upon activation of high limit.
 4. **WATER PRESSURE SWITCH** – Senses boiler water system pressure and shuts down main burner gas when pressure falls to 8 PSI. Boiler control will go into lockout mode upon activation of water pressure switch.
 5. **AIR PRESSURE SWITCH** – Senses burner manifold pressure and prevents ignition sequence activation if blower is not operating.
 6. **THERMODISC TEMPERATURE SWITCH** – Senses combustion chamber outside surface temperature and shuts down main burner gas upon reaching set point of 210° F. Boiler control will go into lockout mode upon reaching set point. This is a manually resettable switch.
- b. Set thermostat or controller above room temperature to call for heat.
 - c. Ignition sequence should try 3 times before going into lockout mode.
 - d. Turn gas supply on.
 - e. Reset by turning 120V power supply off then on.
 - f. Observe boiler operation through one complete cycle.
3. **Low Water Cut-Off (if used)** – Consult the manufacturer's instructions for the low water cut-off operational check procedure.
 4. Check the system to make sure there are no leaks or overfilling problems which might cause excessive make-up water to be added. Make-up water causes liming in the boiler.
 5. Check the expansion tank and automatic fill valve (if used) to confirm that they are operating correctly. If either of these components causes high pressure in the system, the boiler relief valve will weep or open, allowing fresh water to enter the system.
 6. Check the general condition of the system including piping support, joints, etc. Check cleanliness of the radiators, baseboard units and/or convectors. Clean them to the extent possible. If radiators do not heat evenly, vent any remaining air from them.
 7. Review operation with end-user.
 8. Complete the Warranty Card and submit it to Peerless Heater Company.
 9. Hang the Installation, Operation and Maintenance Manual in an accessible position near the boiler.

D. CHECK-OUT PROCEDURE

1. After starting the boiler, be certain all controls are working properly. Check to be sure that boiler will shut down on action of water temperature reaching control board temperature set point.
2. To check operation of the ignition system safety shut-off features:
 - a. Turn gas supply off.

8. TROUBLESHOOTING

A. SHUT-DOWN

In the event of a shut-down caused by thermdisc temperature switch, water pressure switch or high limit switch effecting a shut-down of the main burner and ignition control lockout:

- a. Refer to section "C. Boiler Fault Conditions," item 1., "Limit String Open," in this section and follow the procedure to restart the boiler.
- b. If control goes into ignition lockout mode again refer to the Lighting/Operating Instructions, Section 7, to properly turn off the gas to the boiler.
- c. Turn off electric power to the boiler.
- d. Call a qualified heating service organization or local gas company and have the cause of the shut-down investigated and corrected.
- e. Refer to Lighting/Operating Instructions, Section 7, to re-start boiler.

DANGER

When servicing or replacing items that communicate with the boiler water, be certain that:

- There is no pressure on the boiler.
- The boiler is not hot.
- The power is off.

When servicing all other boiler controls, be certain that:

- The gas is off.
- The electricity is off.

WARNING

Do not use this appliance if any part has been under water. Improper or dangerous operation may result. Immediately call a qualified service technician to inspect the boiler and to replace any part of the control system and any gas control which has been under water.

CAUTION

Label all wires prior to disconnection when servicing controls. Wiring errors can cause improper and dangerous operation. Verify proper operation after servicing.

CAUTION

Should overheating occur or the gas supply fail to shut off, do not turn off or disconnect the electrical supply to the pump. This may aggravate the problem and increase the likelihood of boiler damage. Instead, shut off the gas supply at a location external to the appliance.

B. BOILER FAULT CODES

When a fault condition occurs, the control board goes to a LOCKOUT mode. When in the LOCKOUT mode, the green LED located on the Control board will flash a fault code. The number of times of LED flashes ON/OFF will determine the nature of the fault (see the table below). To reset the Control from the LOCKOUT state, remove and re-apply 120VAC line power to the Control board.

| Description of Fault | # of LED Pulses |
|---|-----------------|
| Limit String Open | 2 |
| Flame Stuck ON | 3 |
| Ignition Fault (No Flame) | 4 |
| Return Water Temperature Thermistor Fault | 5 |
| Supply Water Temperature Thermistor Fault | 6 |
| Air Pressure Switch Fault, Stuck Closed | 7 |
| Air Pressure Switch Fault, Stuck Open | 8 |
| Redundant Gas Valve Relay Stuck ON | 9 |
| Gas Valve Relay Stuck ON | 9 |
| Redundant Gas Valve Relay Stuck OFF | 10 |
| Gas Valve Relay Stuck OFF | 10 |
| Gas Valve wire disconnected | 11 |
| ROM Checksum Failure | 12 |
| RAM Test Failure | 13 |
| 60 Hz Failure | 14 |

C. BOILER FAULT CONDITIONS

1. LIMIT STRING OPEN – 2 PULSES

(Thermodisc Temp Switch, Water Pressure Switch, High Limit Switch)

If the limit string opens, the control will immediately remove power to the gas valve, complete a post purge cycle, and enter lockout mode. To restart the control, make sure that there is a least 10 PSI in the water system. Allow boiler water temperature to cool below control setpoint less the differential, press reset button of thermodisc temperature switch, then remove and re-apply 120 VAC line power.

2. Flame Stuck ON – 3 PULSES

The current state of the flame may be determined by looking through the view port on the combustion chamber. If the flame is stuck ON/OFF then the flame rod insulator or the connector CN6 may not be clean, or unplugged.

3. Ignition Failure (No Flame) – 4 PULSES

If an ignition failure occurs during the trial-for-ignition, the control will return to the pre-purge state and attempt another ignition trial. If after three trials an ignition failure is still occurring, the control will go into the lockout mode.

- Check that the gas valve is operating correctly and the electrical plug is fully connected into the valve.
- Verify that the gas supply is turned on.
- Check for proper connection to the 120VAC line source.

- Check that the flame rod is connected, and also that the flame rod is clean.
- If items "a" through "d" are correct replace the Low-Voltage Cable assembly.

4. Open Return Water Temperature Thermistor – 5 PULSES

The control will sense an open temperature thermistor. If an open thermistor is sensed, the control will go into the lockout state.

- Verify that the return thermistor wiring is properly connected to the control.
- If the temperature thermistor is in any environment of less than 0° F then wait for ambient temperature to rise, or apply heat to the unit.
- If the temperature thermistor is in an environment of more than 230° F then wait for the temperature to drop below 200° F.

5. Open Supply Water Temperature Thermistor – 6 PULSES

The control will sense an open temperature thermistor. If an open thermistor is sensed, the control will go into the lockout state.

- Verify that the return thermistor wiring is properly connected to the control board.
- If the temperature thermistor is in an environment of less than 0° F then wait for ambient temperature to rise, or apply heat to the unit.
- If the temperature thermistor is in an environment of more than 230° F then wait for the temperature to drop below 200° F.

6. Air Pressure Switch Fault Stuck Closed – 7 PULSES

If the control senses the blower pressure switch is closed when it is expected to be open, the control will wait approximately 90 seconds for the fault condition to clear. If after approximately 90 seconds the control still senses the blower pressure switch is closed, the control will go into the lockout state.

- Verify that the blower motor is operational and that the 120 VAC power cable is connected to the blower.
- Check that the wires are connected to the blower air pressure switch and that the air pressure switch is functional. This may require turning the screw in the center of the air pressure switch 1 turn clockwise to correct (initial set-up only).
- After any air pressure switch adjustment, you must cycle the appliance several times to insure proper operation.

7. Air Pressure Switch Fault Stuck Open – 8 PULSES

If the control senses the blower pressure switch is not closed during the pre-purge cycle, the control will attempt two additional pre-purge trials. If after three pre-purge trials the control is still sensing the blower pressure switch is not closing, the control will enter the lockout state.

- a. Check that the blower motor is off and verify that the blower air pressure switch is functional. This may require turning the screw in the center of the air pressure switch in 1/4 turn counter-clockwise to correct (initial set-up only).
- b. After any air pressure switch adjustment, you must cycle the appliance several times to insure proper operation.

8. Redundant Gas Valve/Gas Valve Relay Stuck ON – 9 PULSES

If the controller senses the redundant gas valve or the gas valve relay is stuck ON it will go into the lockout state.

- a. Check for short-circuit(s) from the 24VAC and no continuity between CN4 pins 3 and 4.
- b. If the problem persists, replace the control board.

9. Redundant Gas Valve/Gas Valve Relay Stuck OFF – 10 PULSES

If the controller senses the redundant gas valve or the gas valve relay is stuck OFF, it will go into a lockout state.

Replace the control board.

10. Gas Valve NOT Connected – 11 PULSES

If the controller detects that the gas valve is not connected it will go into the lockout state.

Check the connection to the gas valve.

11. ROM Checksum Failure – 12 PULSES

If the controller detects that the ROM check has failed then it will go into a lockout state.

- a. Turn the 120V power OFF then ON.
- b. If the problem persists, replace the control board.

12. RAM Test Failure – 13 PULSES

If the controller detects that the RAM test failed it will go into a lockout state.

- a. Turn the 120V power OFF then ON.
- b. If the problem persists, replace the control board.

13. 60 Hz Failure – 14 PULSES

If the generator, inverter, or other power source does not provide 60Hz, then the power source must be replaced.

- a. If the power source used supplies 60Hz, turn the 120V power OFF then ON.
- b. If the problem persists, replace the control board.

9. MAINTENANCE

A. GENERAL (WITH BOILER IN USE)

General boiler observation can be performed by the owner. If any potential problems are found, a qualified installer or service technician/agency must be notified.

1. Remove any combustible materials, gasoline and other flammable liquids and substances that generate flammable vapors from the area where the boiler is contained.
2. Observe general boiler conditions (unusual noises, vibrations, etc.)
3. Observe operating temperature and pressure on the combination gauge located in the supply piping on the left side of the boiler. Boiler pressure should never be higher than 5 psi below the rating shown on the safety relief valve (25 psig maximum for a 30 psig rating). Boiler temperature should never be higher than 240° F.
4. Check for water leaks in boiler and system piping.
5. Smell around the appliance area for gas. If you smell gas, follow the procedure listed in the Lighting Operating Instructions to shut down appliance in Section 7, Start-Up Procedure Part B.

B. WEEKLY (WITH BOILER IN USE)

1. Flush float-type low-water cut-off (if used) to remove sediment from the float bowl as stated in the manufacturer's instructions.

C. ANNUALLY (BEFORE START OF HEATING SEASON)

CAUTION

The following annual inspection must be performed by a qualified service technician.

1. Check boiler room floor drains for proper functioning.
2. Check function of the safety relief valve by performing the following test:
 - a. Check valve piping to determine that it is properly installed and supported.
 - b. Check boiler operating temperature and pressure.
 - c. Lift the try lever on the safety relief valve to the full open position and hold it for at least five seconds or until clean water is discharged.

- d. Release the try lever and allow the valve to close. If the valve leaks, operate the lever two or three times to clear the valve seat of foreign matter. It may take some time to determine if the valve has shut completely.
 - e. If the valve continues to leak, it must be replaced before the boiler is returned to operation.
 - f. Check that operating pressure and temperature have returned to normal.
 - g. Check again to confirm that valve has closed completely and is not leaking.
3. Test low-water cut-off (if used) as described by the manufacturer.
 4. Test limit as described in Section 7, Part D, "Check-Out Procedure".
 5. Test function of ignition system safety shut-off features as described in Section 7, Part D, "Check-Out Procedure".

DANGER

When servicing or replacing components, be absolutely certain that the following conditions are met:

- Water, gas and electricity are off.
- The boiler is at room temperature.
- There is no pressure in the boiler.

6. Remove the top/front jacket panel and inspect for any foreign debris that may have entered through air inlet vent.
7. Inspect burner for deterioration. Replace if necessary.
8. With boiler in operation check that condensate is dripping from drain hose. Check for any restriction in condensate drain line.
9. Inspect exhaust vent and air inlet vents for proper support and joint integrity. Repair as necessary. Refer to Section 5, VENTING.
10. Inspect exhaust vent and air inlet vent terminations for obstructions.

WARNING

Leaks in the vent system will cause products of combustion to enter structure (vent system operates under positive pressure).

10. BOILER DIMENSIONS & RATINGS

PI-80

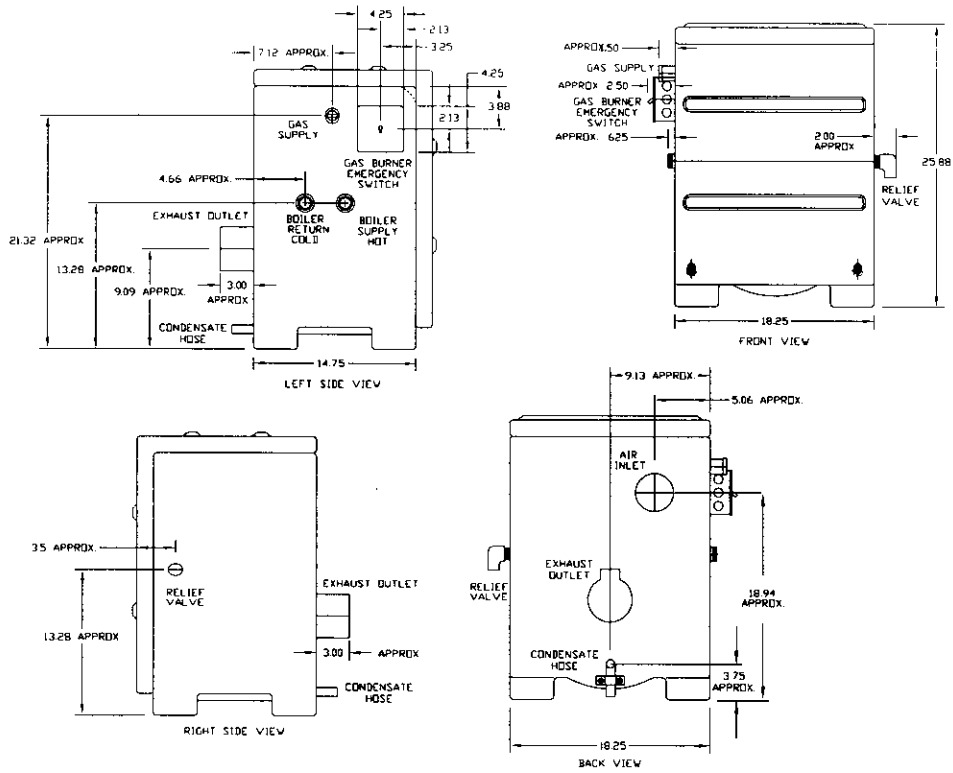

PI-140/PI-199

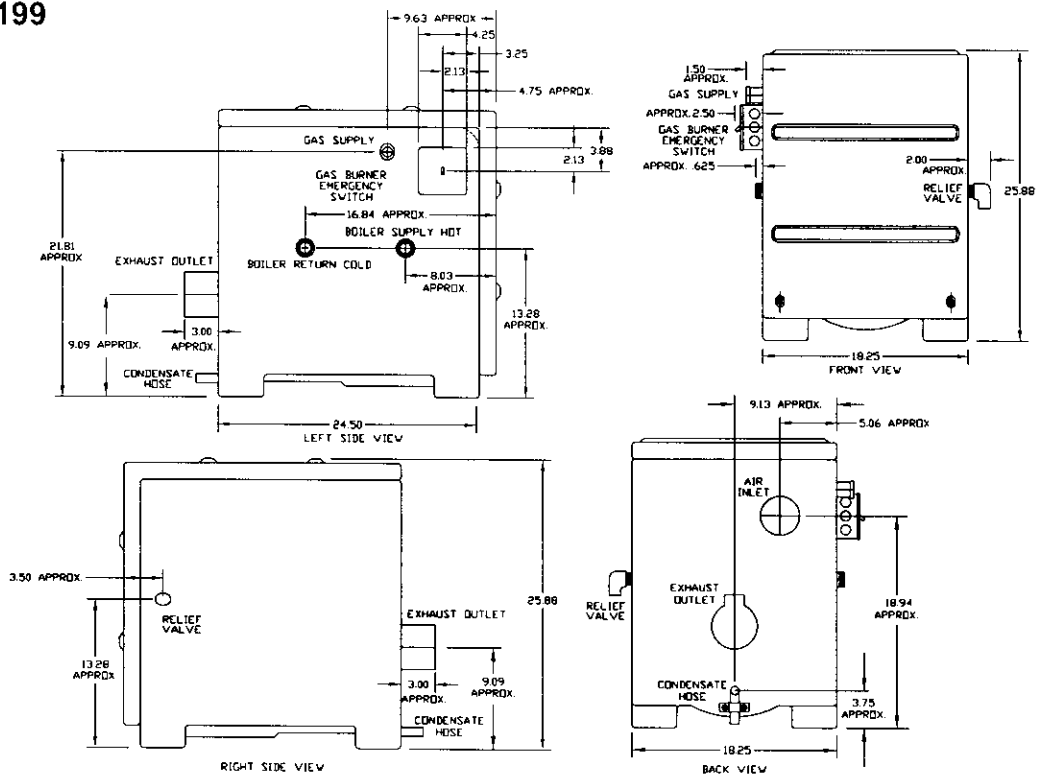

Figure 18: Boiler Dimensions

BOILER DIMENSIONS & RATINGS

| Boiler Model | Supply/Return Connection | Gas Connection | Air Inlet Vent/Exhaust Size |
|--------------|--------------------------|----------------|-----------------------------|
| All | 1-1/4" NPT | 3/4" NPT | 3" |

Table 5: Pinnacle™ Boiler Ratings

| PINNACLE™ BOILER RATINGS | | | | |
|--------------------------|-----------|---------------------------------------|--|----------------------------|
| Boiler Model Number | Input MBH | DOE Heating Capacity MBH ³ | Net I=B=R Ratings Water MBH ^{1,2} | Seasonal Efficiency AFUE % |
| PI-80 | 80 | 74 | 64 | 92 |
| PI-140 | 140 | 129 | 112 | 92 |
| PI-199 | 199 | 183 | 159 | 92 |

1 Net I=B=R water ratings based on an allowance of 1.15.

2 Consult factory before selecting a boiler for installations having unusual piping and pickup requirements, such as intermittent system operation, extensive piping systems, etc.

3 Heating Capacity and Annual Fuel Utilization Efficiency (AFUE) ratings are based on U.S. Government test.



11. REPAIR PARTS

REPAIR PARTS PINNACLE™ GAS BOILER

Repair parts are available from your installer or by contacting Peerless Heater Company, Boyertown, PA 19512-1021. Refer to Table 6 and Figure 19 to assist in ordering parts.

Note: Remember to include boiler model number and serial number when ordering parts.

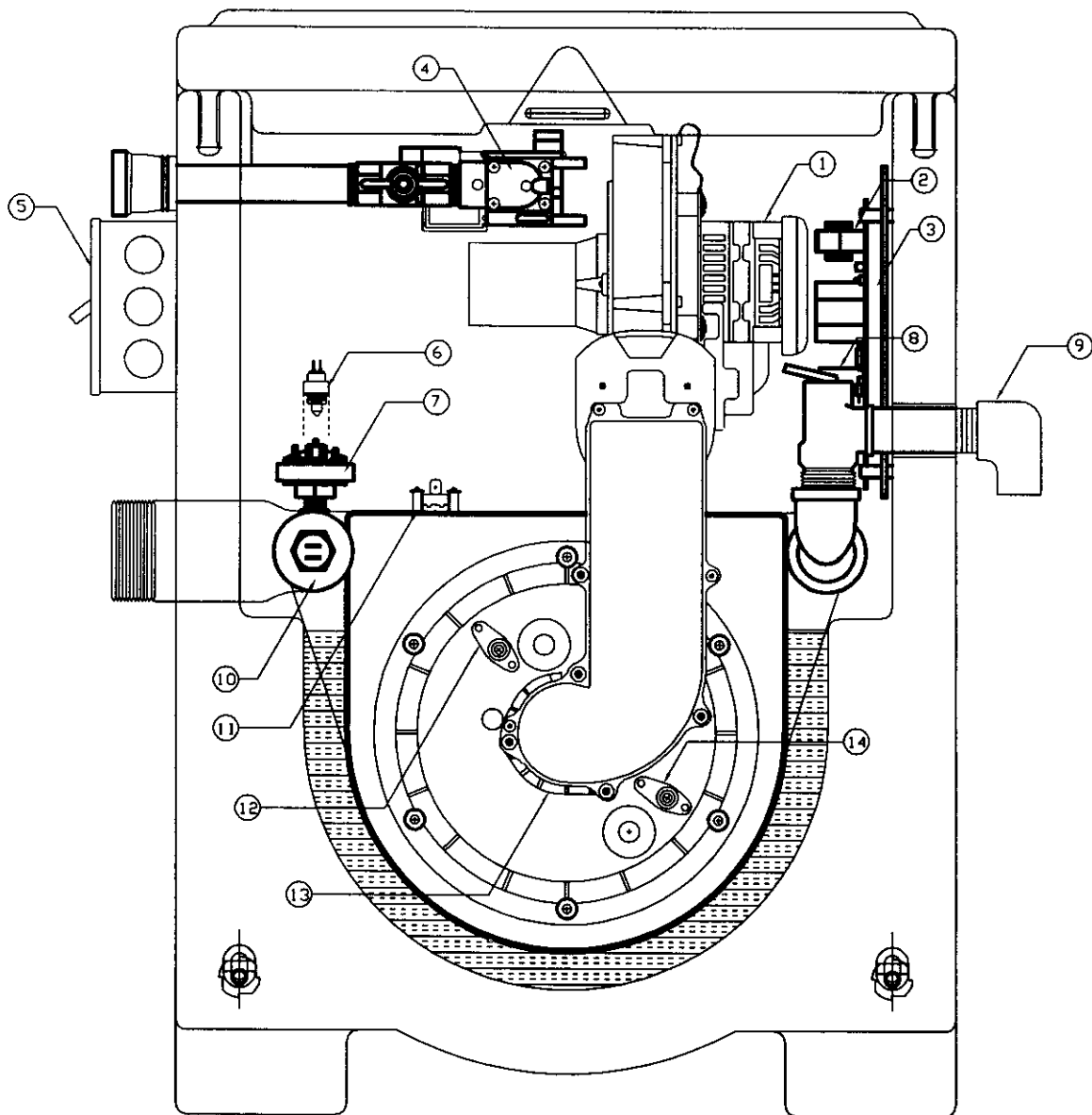

Figure 19: Repair Parts Location Diagram (See Next Page for Ordering Information)

Table 6: Repair Parts

| Item No. | Description | Stock Code | | |
|----------|--|------------|--------|--------|
| | | PI-80 | PI-140 | PI-199 |
| 1 | Blower | 91423 | 91424 | 91425 |
| 2 | Transformer | 91413 | 91413 | 91413 |
| 3 | Control Board | 91404 | 91405 | 91406 |
| 4 | Gas Valve | 91426 | 91426 | 91426 |
| 5 | J/Box | — | — | — |
| 6 | Supply/Return Water Temperature Thermistor | 91422 | 91422 | 91422 |
| 7 | Water Pressure Switch | 91427 | 91427 | 91427 |
| 8 | Air Pressure Switch | 91428 | 91428 | 91428 |
| 9 | Relief Valve | 91430 | 91430 | 91430 |
| 10 | High Limit Water Temperature Switch | 91410 | 91410 | 91410 |
| 11 | Thermodisc Temperature Switch | 91429 | 91429 | 91429 |
| 12 | Spark Electrode | 91411 | 91411 | 91411 |
| 13 | Main Burner (burner not visible in view) | 91407 | 91408 | 91409 |
| 14 | Flame Sensor | 91412 | 91412 | 91412 |

Peerless® Pinnacle™

Stainless Steel Gas Boilers

Installation, Operation & Maintenance Manual

TO THE INSTALLER:

This manual is the property of the owner and must be affixed near the boiler for future reference.

TO THE OWNER:

This boiler should be inspected annually by a Qualified Service Agency.



HI Division
of gama



ASME

CONTROLS



PEERLESS HEATER COMPANY

231 NORTH WALNUT STREET • BOYERTOWN, PA 19512-1021 • PHONE 610-367-2153
www.peerless-heater.com

THE PREFERRED HEATING CHOICE