

Register your product and get support at
www.philips.com/welcome

SE360
SE365



EN User manual

PHILIPS

Contents

1 Important	5
Safety instructions	5
2 Your SE360/SE365	9
What is in the box	9
Overview of the base station	11
Display icons	12
3 Get started	13
Connect the base station	13
Connect the charger	14
Wallmount the base station	14
Install the handset	15
Checking the battery level	15
Set the date and time	15
Set the date and time format	16
What is standby mode?	16
Check the signal strength	16
Switch the handset On/Off	16
4 Calls	17
Make a call	17
End a call	18
Answer a call	18
Adjust the earpiece volume	18
Mute the microphone	18
Turn the speaker on or off	18
Make a second call	18
Answer a second call	18
Toggle between two calls	19
Make a conference call	19
5 Intercom and conference calls	20
Make a call to another handset	20
Transfer a call	20
Make a conference call	20
6 Text and numbers	22
Enter text and numbers	22
Switch between uppercase and lowercase	22
7 Phonebook	23
View the phonebook	23
Search a record	23
Call from the phonebook	23
Access the phonebook during a call	23
Add a record	23
Edit a record	24
Delete a record	24
Delete all records	24
8 Call log	25
View the call records	25
Save a call record to the phonebook	25
Delete a call record	25
Delete all call records	25
Return a call	25
9 Redial list	26
View the redial records	26
Redial a call	26
Save a redial record to the phonebook	26
Delete a redial record	26
Delete all redial records	26
10 Self-defined settings	27
Personalize the phone display	27
Personalize the sounds	27
11 Call features	29
Auto hang up	29
Auto conference	29
Dial mode	29
Select the recall duration	29
Manage the area code	30
Auto prefix	30
First ring	30
12 Extra features	31
Alarm clock	31
Auto clock	31
Keypad lock	31
Locate the handset	32

13 Advanced settings	33
Register the handsets	33
Unregister the handsets	33
Restore default settings	33

14 Telephone answering machine	34
Turn on the answering machine	34
Turn off the answering machine	34
Set the answering machine language	34
Set the answer mode	34
Outgoing messages (OGM)	35
Incoming messages (ICM)	35

15 Default settings	38
----------------------------	----

16 Technical data	39
--------------------------	----

17 Frequently asked questions	40
--------------------------------------	----

1 Important

Safety instructions

Power requirements

- This product requires an electrical supply of 100-240 volts AC. In case of power failure, the communication can be lost.
- The voltage on the network is classified as TNV-3 (Telecommunication Network Voltages), as defined in the standard UL 60950.



Warning

- The Electrical network is classified as hazardous. The only way to power down the charger is to unplug the power supply from the electrical outlet. Ensure that the electrical outlet is always easily accessible.

To avoid damage or malfunction



Caution

- Use only the supplied batteries and adaptor
- Do not allow the charging contacts or the battery to come into contact with metal objects.
- Do not open the handset, base station or charger as you could be exposed to high voltages.
- Do not allow the charger to come into contact with liquids.
- Risk of explosion if battery is replaced by an incorrect type.
- Dispose of used batteries according to the instructions.
- Always use the cables provided with the product.
- For pluggable equipment, the socket-outlet shall be installed near the equipment and shall be easily accessible.
- Handsfree activation could suddenly increase the volume in the earpiece to a very high level: make sure the handset is not too close to your ear.
- This equipment is not designed to make emergency calls when the power fails. An alternative has to be made available to allow emergency calls.
- Do not expose the phone to excessive heat caused by heating equipment or direct sunlight.

- Do not drop your phone or allow objects to fall on your phone.
- Do not use any cleaning agents containing alcohol, ammonia, benzene, or abrasives as these may harm the set.
- Do not use the product in places where there are explosive hazards.
- Do not let small metal objects come into contact with the product. This can deteriorate audio quality and damage the product.
- Active mobile phones in the vicinity may cause interference.
- Metallic objects may be retained if placed near or on the handset receiver.

About operating and storage temperatures

- Operate in a place where temperature is always between 0°C to +35°C (32°F to 95°F).
- Store in a place where temperature is always between -20°C and 70°C (-4°F to 158°F).
- Battery life may be shortened in low temperature conditions.

Equipment approval Information

Your telephone equipment is approved for connection to the public switched telephone network and is in compliance with parts 15 and 68, FCC Rules and Regulations and the Technical Requirements for Telephone Terminal Equipment published by ACTA.

Notification to the local phone company

On the bottom of this equipment is a label indicating, among other information, the US number and Ringer Equivalence Number (REN) for the equipment. You must, upon request, provide this information to your telephone company.

The REN is useful in determining the number of devices you may connect to your telephone line and still have all of these devices ring when your telephone number is called. In most (but not all) areas, the sum of the RENs of all devices connected to one line should not exceed 5. To be certain of the number of devices you may connect to your line as determined by the REN, you should contact your local telephone company.

A plug and jack used to connect this equipment to the premises wiring and telephone network must comply with the applicable FCC Part 68 rules and requirements adopted by the ACTA.

A compliant telephone cord and modular plug is provided with this product. It is designed to be connected to a compatible modular jack that is also compliant. See installation instructions for details.



Note

- This equipment may not be used on coin service provided by the telephone company.
- Party lines are subject to state tariffs, and therefore, you may not be able to use your own telephone equipment if you are on a party line. Check with your local telephone company.
- Notice must be given to the telephone company upon permanent disconnection of your telephone from your line.
- If your home has specially wired alarm equipment connected to the telephone line, ensure the installation of this product does not disable your alarm equipment. If you have questions about what will disable alarm equipment, consult your telephone company or a qualified installer.

Rights of the phone company

Should your equipment cause trouble on your line which may harm the telephone network, the telephone company shall, where practicable, notify you that temporary discontinuance of service may be required. Where prior notice is not practicable and the circumstances warrant such action, the telephone company may temporarily discontinue service immediately. In case of such temporary discontinuance, the telephone company must :

- 1** Promptly notify you of such temporary discontinuance;
- 2** Afford you the opportunity to correct the situation;
- 3** Inform you of your right to bring a complaint to the Commission pursuant to procedures set forth in Subpart E of Part 68, FCC Rules and Regulations.

The telephone company may make changes in its communications facilities, equipment, operations or procedures where such action is required in the operation of its business and not inconsistent with FCC rules and Regulations. If these changes are expected to affect the use or performance of your telephone equipment, the telephone company must give you adequate notice, in writing, to allow you to maintain uninterrupted service.

Interference information

This device complies with Part 15 of the FCC Rules. Operation is subject to the following two conditions :

- 1** This device may not cause harmful interference; and
- 2** This device must accept any interference received, including interference that may cause undesired operation.

This device has been tested and found to comply with the limits for a Class B digital device, pursuant to part 15 of the FCC Rules. These limits are designed to provide reasonable protection against harmful interference in a residential installation. This equipment generates, uses and can radiate radio frequency energy and, if not installed and used in accordance with the instruction manual, may cause harmful interference to radio communications.

However, there is no guarantee that interference will not occur in a particular installation. If this equipment does cause harmful interference to radio or television reception, which can be determined by turning the equipment off and on, the user is encouraged to try to correct the interference by one or more of the following measures:

- Relocate the receiving antenna.
- Increase the separation between equipment and receiver.
- Connect the equipment into an outlet on a circuit different from that to which the receiver is connected.
- Consult the dealer or an experienced radio/TV technician for help.

Also, the Federal Communications Commission has prepared a helpful booklet, "How To Identify and Resolve Radio/TV Interference Problems". This booklet is available from the U.S. Government Printing Office, Washington, D.C. 20402. Please specify stock number 004-000-00345-4 when ordering copies.

Note

- The changes or modifications not expressly approved by the party responsible for compliance could void the user's authority to operate the equipment.

FCC RF radiation exposure statement

This equipment complies with FCC RF radiation exposure limits set forth for an uncontrolled environment. This equipment should be installed and operated with a minimum distance of 20 centimeters between the radiator and your body. This transmitter must not be co-located or operating in conjunction with any other antenna or transmitter.

For hand held operation, this phone has been tested and meets the FCC RF exposure guidelines. Use of other accessories may not ensure compliance with FCC RF exposure guidelines.

Industry Canada technical specifications

This equipment meets the applicable Industry Canada Terminal Equipment Technical Specifications. This is confirmed by the registration number. The abbreviation, IC, before the registration number signifies that registration was performed based on a Declaration of Conformity indicating that Industry Canada technical specifications were met. It does not imply that Industry Canada approved the equipment.

Operation is subject to the following two conditions:

- 1 This device may not cause interference; and
- 2 This device must accept any interference, including interference that may cause undesired operation of the device.

This Class B digital apparatus complies with Canadian ICES-003.

Privacy

Privacy of communications may not be ensured when using this telephone.

Hearing Aid Compatibility (HAC)

This telephone system meets FCC and Industry Canada standards for Hearing Aid Compatibility.

Do not attempt to repair or modify this equipment

Repairs to certified equipment should be made by an authorized maintenance facility designated by the supplier.

Service Centers

USA and CANADA

Phone: 1-800-233-8413

Support: www.support.philips.com

Compliance with EMF

Koninklijke Philips Electronics N.V. manufactures and sells many products targeted at consumers, which, like any electronic apparatus, in general have the ability to emit and receive electromagnetic signals.

One of Philips' leading Business Principles is to take all necessary health and safety measures for our products, to comply with all applicable legal requirements and to stay well within the EMF standards applicable at the time of producing the products.

Philips is committed to develop, produce and market products that cause no adverse health effects. Philips confirms that if its products are handled properly for their intended use, they are safe to use according to scientific evidence available today.

Philips plays an active role in the development of international EMF and safety standards, enabling Philips to anticipate further developments in standardisation for early integration in its products.

Use GAP standard compliance

The GAP standard guarantees that all DECT™ GAP handsets and base stations comply with a minimum operating standard irrespective of their make. The handset and base station are GAP compliant, which means they guarantee the minimum functions: register a handset, take the line, make a call and receive a call. The advanced features may not be available if you use them with other makes. To register and use this handset with a GAP compliant base station of different make, first follow the procedure described in the manufacturer's instructions, then follow the procedure described in this manual for registering a handset. To register a handset from different make to the base station, put the base station in registration mode, then follow the procedure described in the handset manufacturer's instructions.

Recycling

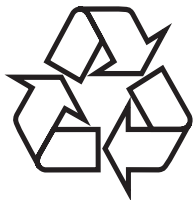

Your product is designed and manufactured with high quality materials and components, which can be recycled and reused.

Never dispose of your product with other household waste. Please inform yourself about the local rules on the separate collection of electrical and electronic products. The correct

disposal of your old product helps prevent potentially negative consequences on the environment and human health.

The packaging of this product is intended to be recycled. Contact your local authorities for information about how to recycle the packaging.



When this logo is attached to a product, it means a financial contribution has been paid to the associated national recovery and recycling system.

The RBRC® seal

The RBRC® Seal on the nickel metal hydride battery indicates that Philips Royal Electronics is voluntarily participating in an industry program to collect and recycle these batteries at the end of their useful lives, when taken out of service within the United States and Canada.

The RBRC® program provides a convenient alternative to placing used nickel metal hydride batteries into the trash or municipal waste, which may be illegal in your area.

Philips's participation in RBRC® makes it easy for you to drop off the spent battery at local retailers participating in RBRC® program or at authorized Philips product service centers. Please call 1-800-8-BATTERY for information on Ni-MH battery recycling and disposal bans/restrictions in your area. Philips's involvement in this program is part of its commitment to protecting our environment and conserving natural resources.



RBRC® is a registered trademark of Rechargeable Battery Recycling Corporation.

2 Your SE360/ SE365

Congratulations on your purchase and welcome to Philips!

To fully benefit from the support that Philips offers, register your product at www.philips.com/welcome.

What is in the box

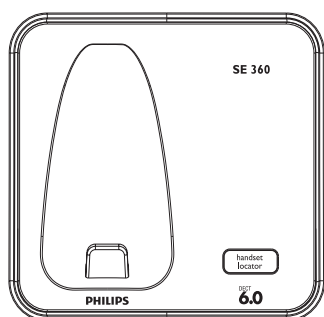

Base station with bracket (SE360)

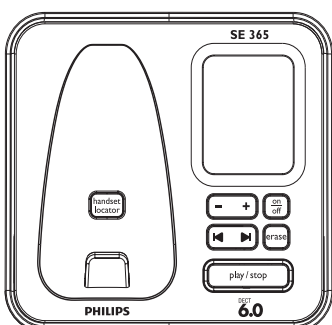

Base station with bracket (SE365)



Handset

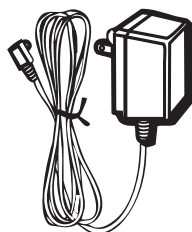

Power supply

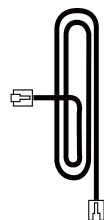

Line cord

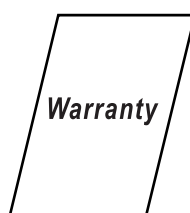

Guarantee

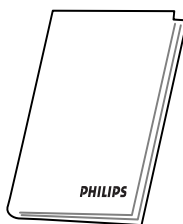

User Manual



Quick start guide



Note

- In some countries, you have to connect the line adaptor to the line cord, then plug the line cord to the line socket.



Note

- In multi-handset packs, there are additional handsets and chargers with power supply units.

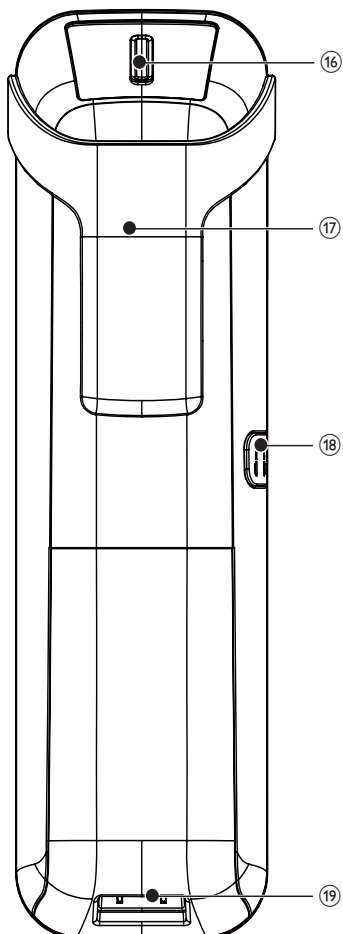
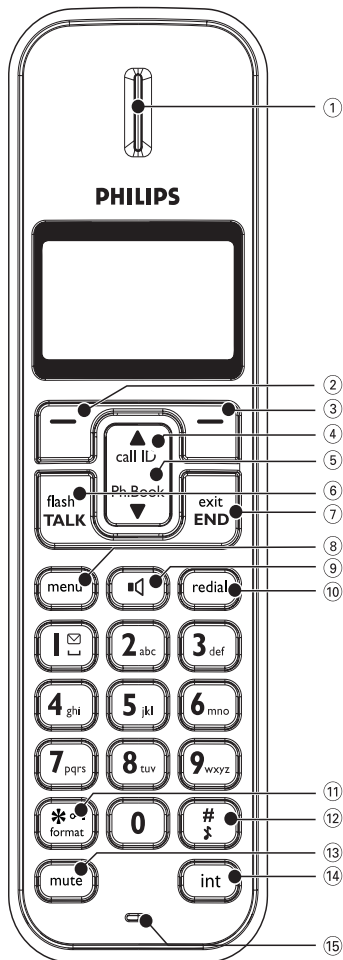

Key	Name	Descriptions
1	Earpiece	
2	OK key	<ul style="list-style-type: none"> • Confirm the selection • Enter the options menu
3	Back/Clear key	<ul style="list-style-type: none"> • Delete the text or digits • Cancel the operation • View more information
4	Call Log/Up key	<ul style="list-style-type: none"> • Scroll up on the menu • Increase the earpiece/speaker volume • Enter the call log
5	Phonebook/Down key	<ul style="list-style-type: none"> • Scroll down on the menu • Decrease the earpiece/speaker volume • Enter the phonebook
6	Talk/Recall key	<ul style="list-style-type: none"> • Make and receive calls • Send the flash signal
7	End /On/Off key	<ul style="list-style-type: none"> • End the call • Exit the menu/operation • Turn the handset on/off
8	Menu key	<ul style="list-style-type: none"> • Access the main menu
9	Speaker key	<ul style="list-style-type: none"> • Turn the speaker on/off
10	Redial key	<ul style="list-style-type: none"> • Enter redial list and dial the recent number

Key	Name	Descriptions
11	Star/Keylock/ Format key	<ul style="list-style-type: none"> • Press and hold to lock/unlock keypad • Edit the caller's number in the call log review
12	Ringer Off/ Pause key	<ul style="list-style-type: none"> • Press to enter a pause • Press and hold to turn the ringer on/off • Switch between the lower and upper case during text editing
13	Mute key	<ul style="list-style-type: none"> • Mute/unmute the microphone
14	Intercom/ Conference key	<ul style="list-style-type: none"> • Make the intercom call • Make the conference call
15	Microphone	
16	Loudspeaker	
17	Belt clip	
18	Headset jack	
19	Battery door	

Overview of the base station

SE360

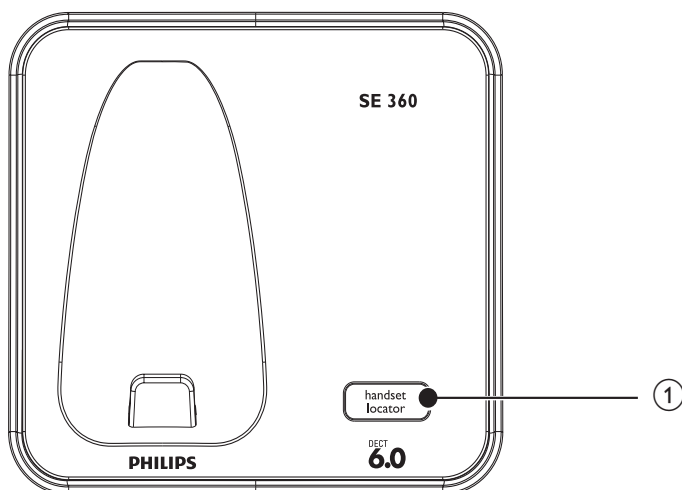

Key	Name	Descriptions
1	handset locator	<ul style="list-style-type: none"> • Find handsets • Enter registration mode

SE365

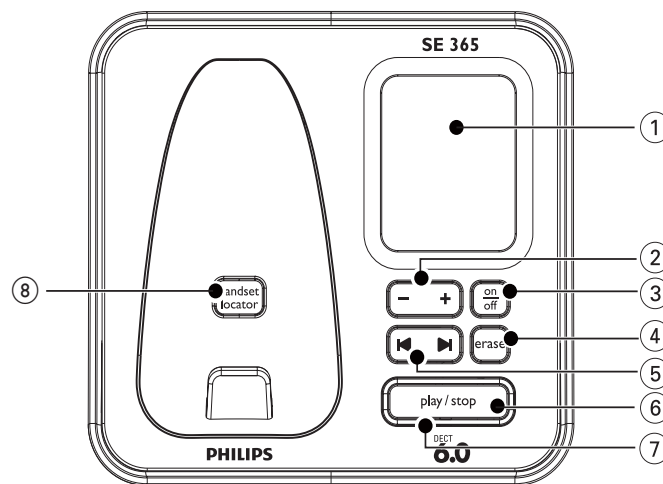













Key	Name	Descriptions
1	Loudspeaker	
2	Volume up/ down key	<ul style="list-style-type: none"> • Increase/decrease the speaker volume
3	On/Off key	<ul style="list-style-type: none"> • Turn the answering machine on/off
4	Delete key	<ul style="list-style-type: none"> • Delete messages
5	Forward/ backward key	<ul style="list-style-type: none"> • Skip forward/backward during playback
6	Play/Stop key	<ul style="list-style-type: none"> • Play messages • Stop message playback

7	LED indicator	<p>Slow flashing at 1 second interval:</p> <ul style="list-style-type: none"> • Unread messages <p>Fast flashing at 0.5 second interval:</p> <ul style="list-style-type: none"> • The answering machine memory is full <p>Steady On:</p> <ul style="list-style-type: none"> • The answering machine is on. • Ongoing answering machine operation. • Ongoing remote operation via the handset
8	Paging key	<ul style="list-style-type: none"> • Find handsets • Enter registration mode

Display icons

In standby mode, the icons shown on the main screen tell you what features are available on your handset.

Icon	Descriptions
	The battery is fully charged.
	The battery is empty.
	It indicates if your phone is linked to a base.
	The call is in progress.
	The alarm is activated.
	The speaker is on.
	The ringer is off.
	Call log
	Answering machine
	There is unheard voice message.
	Scroll up for more options
	Scroll down for more options
	More digits or characters on the right.

3 Get started

! Caution

- Ensure you have read the safety instructions in the "Important" section before you connect and install your handset.

Connect the base station

! Warning

- Risk of product damage! Ensure that the power supply voltage corresponds to the voltage printed on the back or the underside of the phone.
- Use only the supplied power socket to charge the battery.

☰ Note

- The type plate is located on the bottom of the base station.

- 1 Connect the output plug of the power socket to the bottom of the base station.

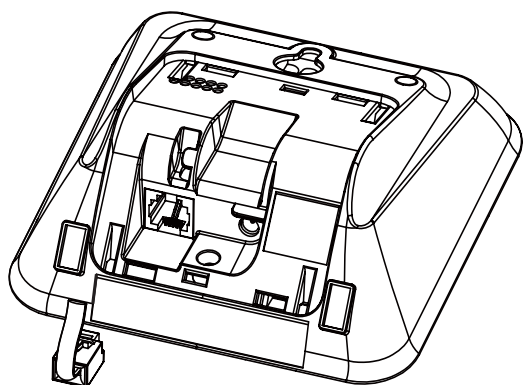

- 2 Connect the power socket to a standard wall outlet.
- 3 Connect the telephone line cord to the phone socket at the bottom of the base station and the wall phone socket.

SE360

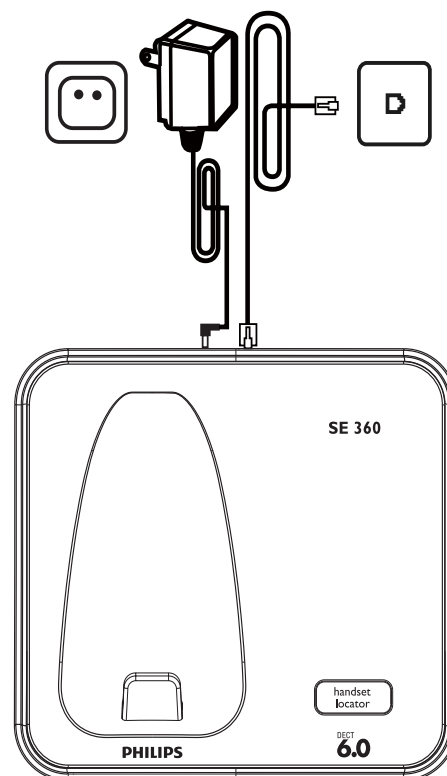

SE365

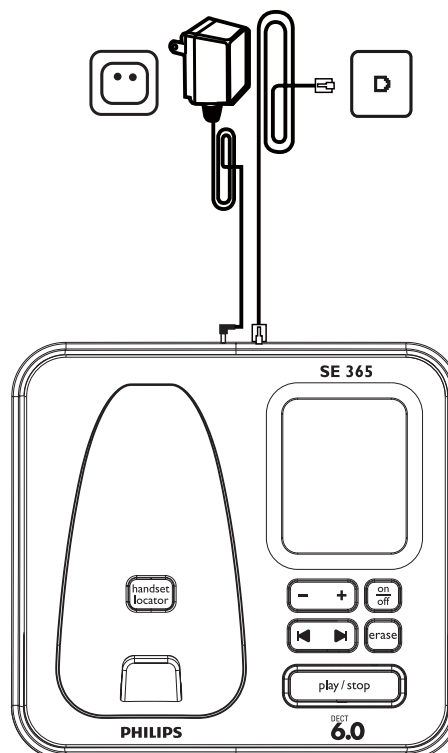

Connect the charger

Note

- The instructions for charger connection below is only available for multi-pack models.

- 1 Connect the output plug of the power socket to the bottom of the charger.

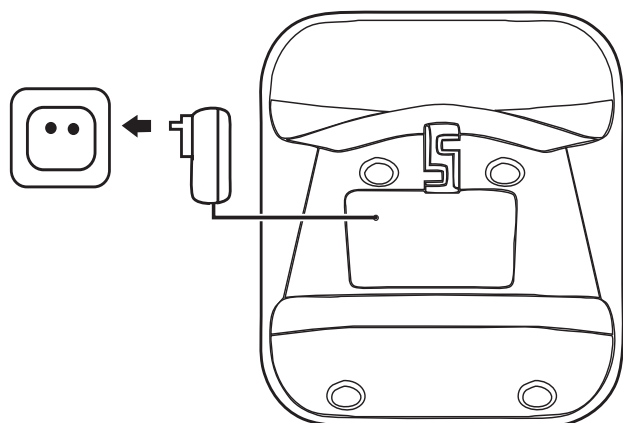

- 2 Connect the power socket to a standard wall outlet.

Wallmount the base station

Warning

- You must follow the instructions below to wallmount the base station.

- 1 Press the two latches on the top of the bracket.
 - » The bracket from the back of the base station is removed.

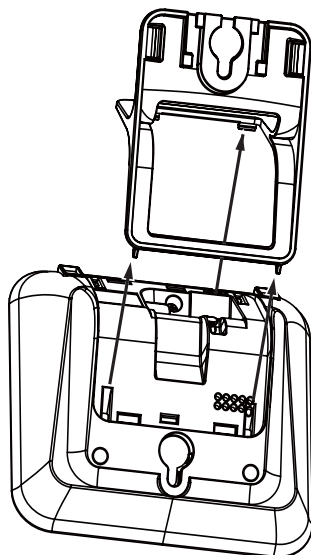

- 2 Turn the bracket around.

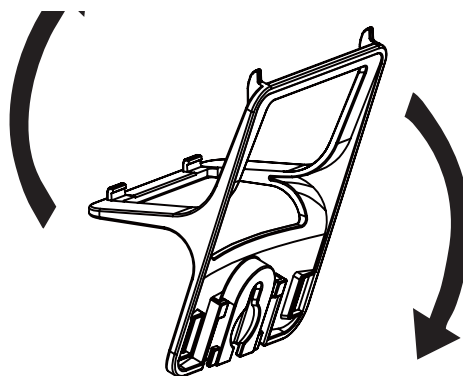

- 3 Re-insert the bracket into the back of the base station.

- 4 Insert screws (not included) into the wall.

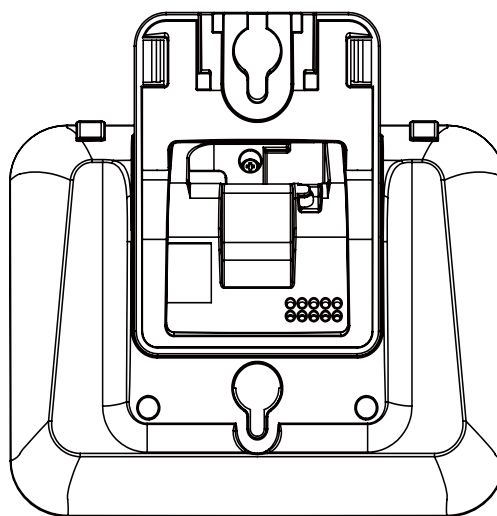

- 5 Align the mounting holes on the back of the base station with the screws on the wall.

- 6 Slide the base station down into place.

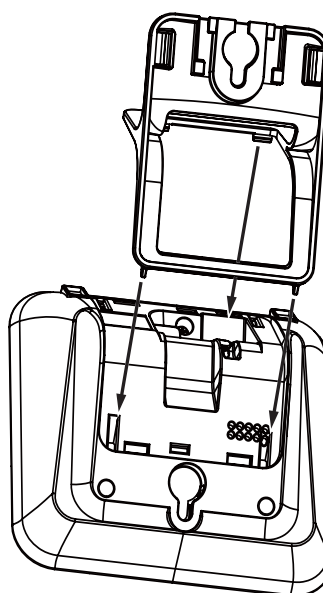

Install the handset



Caution

- Risk of explosion! Keep batteries away from heat, sunshine or fire. Never discard batteries in fire.
- Use only the supplied batteries.
- Risk of decreased battery life! Never mix different brands or types of batteries.



Note

- Charge the batteries for 24 hours before first use.



Warning

- Check the battery polarity when inserting in the battery compartment. Incorrect polarity may damage the product.

- a The batteries are pre-installed in the handset. Pull the battery tape off from the battery door before charging.

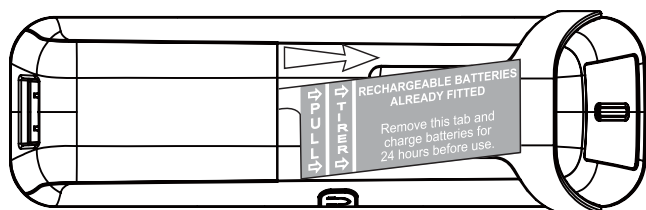

- b Place the handset on the base station to power up.

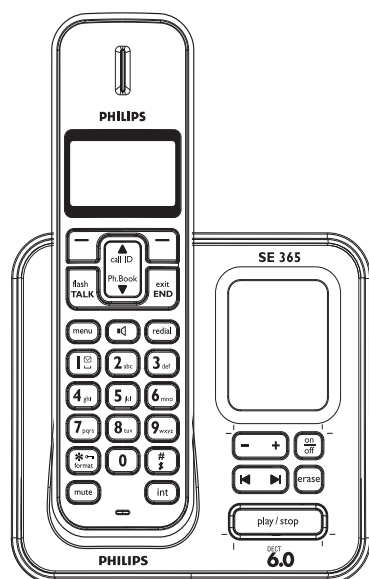

Note

- If the handset becomes warm when the batteries are being charged, it is normal.

Checking the battery level

The battery icon displays the current battery level.



The battery is full.



The battery is empty.
Charge it.

The handsets turn off if the battery is empty. If you are on the phone, you hear warning tones when the battery is almost empty. The call gets disconnected after the warning.

Set the date and time

- 1 Press **menu**.
- 2 Select **[CLOCK & ALARM] > [SET DATE/TIME]**, then press **[OK]** to confirm.
- 3 Press the numeric buttons to enter the date, then press **[OK]** to confirm.
 - » On the handset, the time set menu is displayed.
- 4 Press the numeric buttons to enter the time.
 - If the time is in 12-hour format, press **▲** / **Ph.Book** to select **[AM]** or **[PM]**.
- 5 Press **[OK]** to confirm.

Set the date and time format

- 1 Press **menu**.
- 2 Select **[CLOCK & ALARM] > [SET FORMAT]**, then press **[OK]** to confirm.
- 3 Select **[DATE FORMAT]** or **[TIME FORMAT]**.
- 4 Select the setting. Select **[DD/MM][MM/DD]** as the date display and **[12 HOURS]** or **[24 HOURS]** as the time display. Then press **[OK]** to confirm.
 - » The setting is saved.

What is standby mode?

Your phone is in standby mode when it is idle. The standby screen displays the handset name, handset number, date and time, signal icon, and battery icon.

Check the signal strength

- The signal icon displays the link status between the handset and base station. A steady icon means your handset and the base station are linked. A flashing icon means your handset and the base station are not linked.
- Ensure the handset is linked to the base station before you make or receive calls and carry out the phone functions and features.
- If you hear warning tones when you are on the phone, the handset is almost out of battery or the handset is out of range. Charge the battery or move the handset nearer to the base station.

Switch the handset On/Off

- Press and hold **^{exit}END** to switch off the handset. The handset's screen turns off.

 **Note**

- When the handset is switched off, no call can be received.
- Press **^{exit}END** to switch on the handset. It takes a few seconds for the handset to power up.

4 Calls

Note

- When the power fails, the phone cannot access emergency services.

Tip

- Check the signal strength before you make a call or when you are in a call. For more information, see "Check the signal strength" in the Get started section.

Make a call

You can make a call in these ways:

- Quick call
- Dial before you call
- Redial the most recent number
- Call from the redial list.
- Call from the phonebook list
- Call from the call log

Quick call

- 1 Press ^{flash}**TALK**.
- 2 Dial the phone number.
 - » The number is dialed out.
 - » The duration of your current call is displayed.

Dial before you call

- 1 Dial the phone number
 - To erase a digit, press **[BACK]**.
 - To enter a pause, press and hold **#**.
- 2 Press ^{flash}**TALK** to dial out the call.

Redial the most recent number

- 1 Press ^{flash}**TALK**.
- 2 Press **redial**.
- 3 Press **[OK]**.
 - » The most recent number is then dialed out.

Call from the redial list

You can make a call from the redial list.

Tip

- For more information, see "Redial a call" in the Redial list section.

Call from the phonebook

You can make a call from the phonebook list.

Tip

- For more information, see "Call from the phonebook" in the Phonebook section.

Call from the call log

You can return a call from the outgoing, received or missed call log.

Tip

- For more information, see "Return a call" in the Call log section.

Note

- The call timer displays the talk time of your current call.

Note

- If you hear warning tones, the handset is almost out of battery or the handset is out of range. Charge the battery or move the handset nearer to the base station.

End a call

You can end a call in these ways:

- Press ^{exit}**END**; or
- Place the handset to the base station or charging cradle if the auto hang up is activated.

Answer a call

When the phone rings. Press ^{flash}**TALK** or  to answer the call.



Warning

- When the handset rings or when the handsfree is activated, keep the handset away from your ear to avoid ear damage.



Note

- The caller ID service is network dependent.



Note



- When there is a missed call, the handset displays a notification message.

Turn off the ringer for all incoming calls

There are two ways to turn off the ringer:

- 1 Press and hold **#** in standby mode.
 - »  displays on the screen.
- 2 When the phone rings, press **[BACK]**.

Adjust the earpiece volume

Press ^{call ID} or ^{Ph.Book} to adjust the volume during a call.

The earpiece volume is adjusted and the phone is back to the call screen.

Mute the microphone

- 1 Press **mute** during a call.
 - » The handset displays **[MUTE ON]**.
 - » The caller cannot hear you, but you can still hear his voice.
- 2 Press **mute** again to unmute the microphone.
 - » You can now communicate with the caller.

Turn the speaker on or off

Press .

Make a second call



Note

- This service is network dependent.

- 1 Press ^{flash}**TALK** during a call, then press **[OK]**.
 - » The first call is put on hold.
- 2 Dial the second number.
 - » The number displayed on the screen is dialed out.

Answer a second call



Note

- This service is network dependent.

When there is a periodical beep to notify you of an incoming call, you can answer the call in these ways:

- 1 Press **flash TALK** and **2**_{abc} to answer the call.
 - » The first call is put on hold, and you are now connected to the second call.
- 2 Press **flash TALK** and **I**☒ to end the current call and answer the second call.

Toggle between two calls

Note

- This is a country dependent setting.

You can toggle your calls in these ways:

- 1 Press **flash TALK** ; or
- 2 Press **[OK]** and select **[SWITCH CALLS]**, then press **[OK]** again to confirm.
 - » The current call is put on hold, and you are now connected to the other call.

Make a conference call

Note

- This service is network dependent. Check with the service provider for additional charges.

When you are connected to two calls, press **[OK]**, select **[CONFERENCE]** and then press **[OK]** again to confirm.

- » The two calls are combined and a conference call is established.

5 Intercom and conference calls

An intercom call is a call to another handset that shares the same base station. A conference call involves a conversation among you, another handset user and the outside callers.

Make a call to another handset

Note

- If the base station only has 2 registered handsets, press **int** to make a call to another handset.

- 1 Press **int**. The handsets available for intercom are displayed.
- 2 Select or enter a handset number, then press **[OK]** to confirm.
 - » The selected handset rings.
- 3 Press **flash TALK** on the selected handset.
 - » The intercom is established.
- 4 Press **exit END** to cancel or end the intercom call.

Note

- If the selected handset is occupied in a call, you hear a busy tone.

While you are on the phone

You can go from one handset to another during a call:

- 1 Press **int**.
- 2 The current caller is put on hold.
- 3 Select or enter a handset number, then press **[OK]** to confirm.
 - » Wait for the other side to answer your call.

Toggle between calls

Press **int** to switch between the outside call and the intercom call.

Transfer a call

- 1 Press **int** during a call.
- 2 Select or enter the handset number, then press **[OK]** to confirm.
- 3 Press **exit END** when the other side answers your call.
 - » The call is now transferred to the selected handset.

Make a conference call

A 3-way conference call is a call between you, another handset user and the outside callers. It requires two handsets to share the same base station.

During an external call

- 1 Press **int** to initiate an internal call.
 - » The handsets available for intercom are displayed.
 - » The external caller is put on hold.
- 2 Select or enter a handset number, then press **[OK]** to confirm.
 - » The selected handset rings.
- 3 Press **flash TALK** on the selected handset.
 - » The intercom is established.
- 4 Press and hold **int** on your handset.
 - » You are now on a 3-way conference call with the external call and the selected handset.
- 5 Press **exit END** to end the conference call.



Note

- Press ^{flash}**TALK** to join an ongoing conference with another handset.

During the conference call

- 1 Press **int** to put the external call on hold and go back to the internal call.
 - » The external call is put on hold.
- 2 Press **int** to toggle between the external and internal call.
- 3 Press and hold **int** to establish the conference call again.





Note

- If a handset hangs up during the conference call, the other handset remains connected to the external call.

6 Text and numbers

You can enter text and numbers for handset name, phonebook records, and other menu items.

Enter text and numbers

- 1 Press once or several times on the alphanumeric key to enter the selected character.
- 2 Press **[BACK]** to delete the character. Press  or  move the cursor left and right.

Key	Characters (Upper case)
0	. 0 , / : ; " ' ! ? ; * + - % \ ^ ~
1	[Sp] 1 @ _ # = < > () & € £ \$ ¥ [] { } ¨ § ...
2	A B C 2 À Â Æ Á Ã Ä Å Ā Ą Ç Ć Ć
3	D E F 3 Ď ě É Ě È É Ê Ë Ě Δ Φ
4	G H I 4 Ğ Ĩ Î Ï Ĩ Ĩ Γ
5	J K L 5 Ľ Ł Ł Ľ
6	M N O 6 Ñ Ñ Ñ Ó Ô Õ Ö Ö
7	P Q R S 7 Ŕ Ŗ Š Š Š β Π Θ Σ
8	T U V 8 Ţ Ť Ù Ú Û Ü Û Ů Ů
9	W X Y Z 9 Ý Ž Ž Ž ŕ Ø Ω Ξ Ψ

Key	Characters (Lower case)
0	. 0 , / : ; " ' ! ? ; * + - % \ ^ ~
1	[Sp] 1 @ _ # = < > () & € £ \$ ¥ [] { } ¨ § ...
2	a b c 2 à â æ á ã ä å ā ą ç ć ċ
3	d e f 3 đ ě é ě è é ê ë ě Δ Φ
4	g h i 4 ğ ĩ î ï ĩ ĩ Γ
5	j k l 5 ĵ ł ł ĵ
6	m n o 6 ñ ñ ñ ó ô õ ö ö
7	p q r s 7 ŕ ť š š š β π θ σ
8	t u v 8 ŧ ŧ ù ú û ü ù ů ů
9	w x y z 9 ý ž ž ž ŕ ø Ω Ξ Ψ

Example to write "PAUL"

Press 7 once: P

Press 2 once: A

Press 8 two times: U

Press 5 three times: L

Switch between uppercase and lowercase

By default, the first letter of each word in a sentence is uppercase and the rest is lowercase. Press **#** to switch between the uppercase and lowercase letters.

7 Phonebook

This phone has a phonebook that stores up to 100 records. You can access the phonebook from the handset. Each record can have a name up to 14 characters long and a number up to 24 digits long.

View the phonebook

Note

- You can view the phonebook on one handset only each time.



- 1 Press .
- 2 Select a contact and view the available information.

Search a record

You can search the phonebook records in these ways:

- Scroll the contacts list.
- Enter the first character of the contact.



Scroll the contact list

Access the phonebook menu, then press  and  to scroll through the phonebook entries.

Enter the first character of a contact

- 1 Access the phonebook menu.
- 2 Select [LIST].
- 3 Press the alphanumeric key that corresponds to the character.
 - » The first record that starts with this character is displayed.

Call from the phonebook

- 1 Press  to access the phonebook.
- 2 Select a contact in the phonebook list.
- 3 Press  to make the call.

Access the phonebook during a call

- 1 Press [OK], select [PHONEBOOK] then press [OK] again to confirm.
- 2 Select the contact, then press [OK] to confirm.
 - » The number can be viewed.

Add a record

Note

- If your phonebook memory is full, the handset displays a notification message. Delete some records to add new ones.

- 1 Press **menu**.
- 2 Select [PHONEBOOK] > [NEW ENTRY], then press [OK] to confirm.
- 3 Enter the name then press [OK] to confirm.
- 4 Enter the number, then press [OK] to confirm.

Tip

- For more information on how to edit the name and number, see the section on Text and numbers.

Note

- The phonebook only saves new number.



Tip

- Press and hold **#** to insert a pause.

» Your new record is saved.

Edit a record

- 1 Press **menu**.
- 2 Select **[PHONEBOOK] > [EDIT ENTRY]**, then press **[OK]** to confirm.
- 3 Select the contact, then press **[OK]** to confirm.
- 4 Edit the name, then press **[OK]** to confirm.
- 5 Edit the number, then press **[OK]** to confirm.
 - » The record is saved.

Delete a record

- 1 Press **menu**.
- 2 Select **[PHONEBOOK] > [DELETE]**, then press **[OK]** to confirm.
- 3 Select a contact, then press **[OK]** to confirm.
 - » The handset displays a confirmation request.
- 4 Press **[OK]** to confirm.
 - » The record is deleted.

Delete all records

- 1 Press **menu**.
- 2 Select **[PHONEBOOK] > [DELETE ALL]**, press **[OK]** to confirm.
 - » The handset displays a confirmation request.
- 3 Press **[OK]** to confirm.
 - » All records are deleted.