

Register your product and get support at
www.philips.com/welcome

SE659



master US EN Telephone Answering Machine



Warning

Use only rechargeable batteries.

Charge the handset for 24 hours before use.

PHILIPS

Table of contents

1	Important Safety Instructions	5
2	Environment and safety	7
2.1	Safety information	7
2.2	Power requirements	7
2.3	Battery requirements	7
2.4	Telephone connection	7
2.5	Environmental care	8
2.6	Precautions	8
2.7	Equipment Approval Information	9
2.7.1	Notification to the Local Telephone Company	9
2.7.2	Rights of the Phone Company	9
2.8	Interference Information	10
2.9	Hearing Aid Compatibility (HAC)	11
2.10	FCC RF Radiation Exposure Statement	11
3	Important	11
3.1	Power requirements	12
3.2	Electric, Magnetic and Electromagnetic Fields ("EMF")	13
3.3	Recycle your batteries	13
4	The RBRC® seal	13
4.1	Service Centers	14
5	Your phone	16
5.1	What's in the box	16
5.2	Overview of your handset	17
5.3	Display icons and Messages	20
5.4	Overview of the base station	22
5.5	Base station display	24
6	Conventions Used in this Manual	24
7	Getting started	25
7.1	Connect the base station	25
7.2	Wall mounting the base	26
7.3	Install your phone	27
7.3.1	Install battery	27
7.3.2	Charge battery	27
7.4	Remove/Attach belt clip	28
7.5	Install optional headset	28
7.6	Power up	28
7.7	Using multipacks	29
7.8	Handset menu structure	30
8	Using your phone	36
8.1	Make a call	36
8.1.1	Predialling	36
8.1.2	Direct dialling	36
8.1.3	Call from redial list	36
8.1.4	Call from the call log	37
8.1.5	Call from the phonebook	37
8.1.6	Call from the phonebook while already on the phone	37
8.1.7	Call using Direct Access Memory	38
8.1.8	Enter a Dialing Pause	38
8.2	Answer a call	38
8.2.1	Handsfree answering with handset	38

8.3	Answer a call on the other line	39	9.9.3	Set Alarm (Handset only)	46
8.4	End a call	39	9.9.4	Set Alarm Tone (Handset only)	46
8.5	Using the Redial list	39	10	Using your Phonebook	46
8.5.1	Access Redial list	39	10.1	Store a contact in the phonebook	46
8.5.2	View redial number details	39	10.2	Access phonebook	47
8.5.3	Save a redial number into the phonebook	39	10.3	Modify a phonebook entry	47
8.5.4	Delete a redial number	40	10.4	Select phonebook melody (Handset only)	47
8.5.5	Delete all redial numbers	40	10.5	Delete a phonebook entry	48
9	Use more of your phone	41	10.6	Delete all phonebook entries	48
9.1	Switch the handset off/on	41	10.7	Direct Access Memory	48
9.2	Handset keypad lock/unlock	41	10.7.1	Add/Edit Direct Access Memory	48
9.3	Text or number entry	41	10.7.2	Delete Direct Access Memory	49
9.4	Call waiting	41	11	Using the Call log	49
9.5	Call in progress	41	11.1	Access the Call log	49
9.5.1	Adjust earpiece or speaker volume	42	11.1.1	To choose the format for call log display	50
9.5.2	Mute/Unmute microphone	42	11.2	Save call list entry into the phonebook	50
9.5.3	Activate/Deactivate handset loudspeaker mode	42	11.3	Delete a call list entry	51
9.6	Chain dialing	42	11.4	Delete all call list entries	51
9.7	Using the Intercom	42	12	Personal settings	51
9.7.1	Intercom another unit	42	12.1	Change the Handset Name (Handset only)	51
9.7.2	Transfer an external call to another unit	43	12.2	Ring Settings	51
9.7.3	Answer an external call during intercom	43	12.2.1	Set the Ring Volume	51
9.7.4	Switch between an internal and external call	43	12.2.2	Set the Ring Tones	52
9.7.5	Establish a three-party conference call	43	12.2.3	Activate/Deactivate Key Beep	53
9.8	Locate Handset	44	12.3	Change the Display Language	53
9.9	Clock and Alarm settings	45			
9.9.1	Set Date and Time	45			
9.9.2	Set Time and Date Format	45			

12.4	Select the Display Wallpaper (Handset only)	53	14.1.1	Change Call Forward Activation Codes	63
12.5	Select the Color Theme (Handset only)	53	14.1.2	Change Call Forward Deactivation Code	64
12.6	Set the Display Contrast	54	14.2	Call Forward when Busy	64
12.7	Set the Backlight Time (Handset only)	54	14.2.1	Change Call Forward when Busy Activation Codes	64
12.8	Deactivate/Activate Auto Hang-Up (Handset only)	54	14.2.2	Change Call Forward when Busy Deactivation Code	65
12.9	Changing the Line Setting (Base Station only)	54	14.3	Call Forward when Unanswered	65
13	Advanced settings	55	14.3.1	Change Call Forward when Unanswered Activation Codes	66
13.1	Easy Call	55	14.3.2	Change Call Forward when Unanswered Deactivation Code	66
13.1.1	Set Easy Call to On or Off	55	14.4	Voice Mail	66
13.1.2	Set Easy Call number	56	14.4.1	Access Voice Mail	66
13.2	Auto Conference	56	14.4.2	Set Voice Mail Number	67
13.3	Call Barring	56	14.5	Voice Mail 2	67
13.3.1	Set Call Barring Mode	56	14.6	Information Service	67
13.3.2	Set a Call Barring number	57	14.6.1	Access Info Service	67
13.4	XHD Sound	57	14.6.2	Set Info Service Number	67
13.5	Change PIN	57	14.7	Information Service 2	67
13.6	Registration	58	14.8	Call Return	68
13.6.1	Easy registration	58	14.8.1	Access the Call Return Service	68
13.6.2	Manual registration	58	14.8.2	Set Call Return Service Number	68
13.7	Unregister	59	14.9	Cancel Call Back	68
13.8	Reset Unit	59	14.9.1	Call the Cancel Call Back Number	68
13.9	Set Area Code	59	14.9.2	Set the Cancel Call Back Number	68
13.10	Set Auto Prefix	60	14.10	Withhold ID	69
13.11	Change Flash time	60	14.10.1	Activating Withhold ID	69
13.12	Change the Dial Mode	60	14.10.2	Set the Withhold ID Code	69
13.13	Set First Ring Detection	61			
13.14	Changing the Line Setting (Handset only)	61			
13.15	Default Settings	62			
14	Network Service	63			
14.1	Call Forward	63			

15	Telephone answering machine (TAM)	69
15.1	Playing Messages	70
15.1.1	Playback of messages via handset (Handset only)	70
15.1.2	Functions available during playback	70
15.2	Delete all messages (Handset only)	70
15.3	Turn the Answering Machine On/Off from the Handset (Handset only)	71
15.4	Play, Record, or Delete an Outgoing Message	71
15.5	Set the Answer mode	71
15.6	Answering Machine Settings	72
15.6.1	Ring Delay	72
15.6.2	Remote Access	72
15.6.3	Handset Screening	73
15.6.4	Setting the Outgoing Message Language	74
16	Technical data	74
17	Frequently asked questions	75
17.1	Connection	75
17.2	Set-up	75
17.3	Sound	75
17.4	Product behaviour	76
18	INDEX	78

1 Important Safety Instructions

Some of the following information may not apply to your particular product; however, when using telephone equipment, basic safety precautions should always be followed to reduce the risk of fire, electric shock and injury to persons, including the following:

- 1 Read and understand all instructions.
- 2 Follow all warnings and instructions marked on the product.
- 3 Unplug this product from the wall outlet before cleaning. Do not use liquid cleaners or aerosol cleaners. Use a damp cloth for cleaning.
- 4 Telephones should not be used while you are in a bathtub, shower or pool. Immersion of the telephone or handset in water could cause an electrical shock.
- 5 Slots and openings in the cabinet back or bottom are provided for ventilation, to protect it from overheating. These openings must not be blocked or covered. The openings should never be blocked by placing the product on the bed, sofa, rug, or other similar surface. This product should not be placed in a built-in installation unless proper ventilation is provided.
- 6 This product should be operated only from the type of power source indicated on the marking label. If you are not sure of the type of power supply to your home, consult your dealer or local power company.
- 7 Do not allow anything to rest on the power cord. Do not locate this product where the cord will be abused by persons walking on it.
- 8 Do not overload wall outlets and extension cords as this can result in the risk of fire or electric shock.
- 9 Never push objects of any kind into this product through cabinet slots as they may touch dangerous voltage points or short out parts that could result in a risk of fire or electric shock.
Never spill liquid of any kind on the product.
- 10 To reduce the risk of electric shock, do not disassemble this product, but take it to a qualified service personnel when service or repair work is required. Opening or removing covers may expose you to dangerous voltages or other risks. Incorrect reassembly can cause electric shock when the appliance is subsequently used.
- 11 Do not expose the product to extreme temperatures such as areas near a hot radiator or stove or in a hot car.
- 12 Do not place lighted candles, cigarettes, cigars, etc., on the telephone.
- 13 Never touch uninsulated telephone wires or terminals unless the

telephone line has been disconnected at the network interface.

- 14** Never install or modify telephone wiring during a lightning storm.
- 15** Never install telephone jacks in wet locations unless the jack is specifically designed for wet locations.
- 16** Use caution when installing or modifying telephone lines to prevent electrical shock and/or fire.
- 17** Unplug this product from the wall outlet and refer servicing to qualified service personnel under the following conditions:
 - A** When the power supply cord or plug is damaged or frayed.
 - B** If the product has been exposed to rain or water.
 - C** If the product does not operate normally by following the operating instructions.
 - D** If the product's cabinet has been damaged.
 - E** If the product exhibits a distinct change in performance.
- 18** Avoid using a telephone (other than a cordless type) during an electrical storm. There may be a remote risk of electric shock from lightning.
- 19** Do not use the telephone to report a gas leak in the vicinity of the leak.
- 20** Do not place this product on an unstable cart, stand or table. The product may fall, causing serious damage to the product.

IF YOUR PRODUCT UTILIZES BATTERIES, THE FOLLOWING

ADDITIONAL PRECAUTIONS SHOULD BE OBSERVED:

- 1** Use only the type and size of battery(ies) specified in the user manual.
- 2** Do not dispose of the battery(ies) in fire. They may explode. Check with local codes for possible special disposal instructions.
- 3** Do not open or mutilate the battery(ies). Released electrolyte is corrosive and may cause damage to the eyes or skin. It may be toxic if swallowed.
- 4** Exercise care in handling battery(ies) in order not to short out the battery(ies) with conducting materials such as rings, bracelets, and keys. The battery(ies) or conductor may overheat and cause burns.
- 5** Do not attempt to recharge the battery(ies) provided with or identified for use with this product that are not intended to be charged. The battery(ies) may leak corrosive electrolyte or explode.
- 6** Do not attempt to rejuvenate the battery(ies) provided with or identified for use with this product by heating them. Sudden release of the battery(ies) electrolyte may occur causing burns or irritation to eyes or skin.
- 7** When replacing battery(ies), all batteries should be replaced at the same time. Mixing fresh and discharged batteries could increase internal cell pressure and rupture

the discharged battery(ies). (Applies to products employing more than one separately replaceable primary battery.)

- 8 When inserting battery(ies) into this product, the proper polarity or direction must be observed. Reverse insertion of battery(ies) can cause charging, and that may result in leakage or explosion.
- 9 Remove battery(ies) from this product if storing over 30 days because the battery(ies) could leak and damage the product.
- 10 Discard “dead” battery(ies) as soon as possible since “dead” batteries are more likely to leak in a product.
- 11 Do not store this product, or the battery(ies) provided with or identified for use with this product, in high temperature areas. Batteries that are stored in a freezer or refrigerator for the purpose of extending shelf life should be protected from condensation during storage and defrosting. Batteries should be stabilized at room temperature prior to use after cold storage.
- 12 If your product uses rechargeable battery(ies), charge the battery(ies) only in accordance with the instructions and limitation specified in the User Manual.

SAVE THESE INSTRUCTIONS

2 Environment and safety

2.1 Safety information

This telephone is not designed for making emergency telephone calls when the power fails. An alternative should be made available for access to emergency calling.

2.2 Power requirements

This product requires an electrical supply of 120 volts, single phase alternating current, excluding IT installations defined in standard UL 60950.

2.3 Battery requirements

The handset requires power source of two rechargeable NiMH batteries, size AAA 1.2V 600mAh (Hr11/45). IF THE INCORRECT TYPE OF BATTERIES ARE USED, A WARNING MESSAGE WILL BE DISPLAYED.

Use only Philips Multi-Life 600mAh rechargeable NiMH batteries.

For servicing or replacement, you can purchase a suitable headset through service centre or retail shop.

2.4 Telephone connection

The voltage on the network is classified as TNV- 3 (Telecommunication Network Voltages, as defined in the standard UL

60950). Following a power cut, the call in progress is lost.

Caution

Users should ensure for their own protection that the electrical ground connections of the power utility, telephone lines and internal metallic water pipe system, if present, are connected together. This precaution may be particularly important in rural areas.

2.5 Environmental care

Please remember to observe the local regulations regarding the disposal of your packaging materials, exhausted batteries and old phone and where possible promote their recycling.

2.6 Precautions

- Do not allow the handset to come into contact with liquids or moisture.
- Do not open the handset, base station or charger. This could expose you to high voltages.
- Do not allow the charging contacts of the charger or the battery to come into contact with extraneous conductive materials.
- There is a slight chance that the telephone could be damaged by an electrical storm. It is recommended that users unplug the phone from the USB socket and the phone line from the phone wall socket during a storm.
- Because the phone works by sending radio signals between the base unit and the handset, wearers of hearing

aids may experience interference in the form of a humming noise.

- We advise that this phone should not be used near intensive care medical equipment, nor by persons with pacemakers.
- Your phone can interfere with electrical equipment such as answering machines, TV and radio sets, clock radios and computers if placed too close. It is recommended that you position the base unit at least one meter from such appliances.

Caution

Use only the mains adapter supplied with this telephone. Incorrect adapter polarity or voltage can seriously damage the unit.

Base adapter:

Input: 100 V - 240 VAC 50/60 Hz

Output: 6 VDC 500 mA

Charger adapter:

Input: 100 V - 240 VAC 50/60 Hz

Output: 6 VDC 210 mA

Caution

RISK OF EXPLOSION IF BATTERY IS REPLACED BY AN INCORRECT TYPE.

Never use non-rechargeable batteries; use recommended type supplied with this telephone. NiMH batteries must be disposed of in accordance with the applicable waste disposal regulations.

FCC CERTIFICATION NUMBER IS LOCATED ON THE CABINET BOTTOM

The term "IC:" before the certification number signifies that Industry Canada technical specifications were met. This certification means that the equipment

meets certain radio communications and operational requirements.

2.7 Equipment Approval Information

Your telephone equipment is approved for connection to the public switched telephone network and is in compliance with parts 15 and 68, FCC Rules and Regulations and the Technical Requirements for Telephone Terminal Equipment published by ACTA.

2.7.1 Notification to the Local Telephone Company

On the bottom of this equipment is a label indicating, among other information, the US number and Ringer Equivalence Number (REN) for the equipment. You must, upon request, provide this information to your telephone company.

The REN is useful in determining the number of devices you may connect to your telephone line and still have all of these devices ring when your telephone number is called. In most (but not all) areas, the sum of the RENs of all devices connected to one line should not exceed 5. To be certain of the number of devices you may connect to your line as determined by the REN, you should contact your local telephone company. A plug and jack used to connect this equipment to the premises wiring and telephone network must comply with the

applicable FCC Part 68 rules and requirements adopted by the ACTA. A compliant telephone cord and modular plug is provided with this product. It is designed to be connected to a compatible modular jack that is also compliant. See installation instructions for details.

Notes

- This equipment may not be used on coin service provided by the telephone company.
- Party lines are subject to state tariffs, and therefore, you may not be able to use your own telephone equipment if you are on a party line. Check with your local telephone company.
- Notice must be given to the telephone company upon permanent disconnection of your telephone from your line.
- If your home has specially wired alarm equipment connected to the telephone line, ensure the installation of this product does not disable your alarm equipment. If you have questions about what will disable alarm equipment, consult your telephone company or a qualified installer.

2.7.2 Rights of the Phone Company

Should your equipment cause trouble on your line which may harm the telephone network, the telephone company shall, where practicable, notify you that

temporary discontinuance of service may be required. Where prior notice is not practicable and the circumstances warrant such action, the telephone company may temporarily discontinue service immediately. In case of such temporary discontinuance, the telephone company must:

(1) promptly notify you of such temporary discontinuance; (2) afford you the opportunity to correct the situation; and (3) inform you of your right to bring a complaint to the Commission pursuant to procedures set forth in Subpart E of Part 68, FCC Rules and Regulations. The telephone company may make changes in its communications facilities, equipment, operations or procedures where such action is required in the operation of its business and not inconsistent with FCC rules and Regulations. If these changes are expected to affect the use or performance of your telephone equipment, the telephone company must give you adequate notice, in writing, to allow you to maintain uninterrupted service.

2.8 Interference Information

This device complies with Part 15 of the FCC Rules. Operation is subject to the following two conditions:

(1) this device may not cause harmful interference; and (2) this device must accept any interference received, including interference that may cause undesired operation.

This equipment has been tested and found to comply with the limits for a Class B digital device, pursuant to Part 15 of the FCC Rules.

These limits are designed to provide reasonable protection against harmful interference in a residential installation. This equipment generates, uses, and can radiate radio frequency energy and, if not installed and used in accordance with the instructions, may cause harmful interference to radio communications. However, there is no guarantee that interference will not occur in a particular installation.

If this equipment does cause harmful interference to radio or television reception, which can be determined by turning the equipment off and on, the user is encouraged to try to correct the interference by one or more of the following measures:

- Reorient or relocate the receiving antenna (that is, the antenna for radio or television that is “receiving” the interference).
- Reorient or relocate and increase the separation between the telecommunications equipment and receiving antenna.
- Connect the telecommunications equipment into an outlet on a circuit different from that to which the receiving antenna is connected.

If these measures do not eliminate the interference, please consult your dealer or an experienced radio / television technician for additional suggestions. Also, the Federal Communications

Commission has prepared a helpful booklet, "How To Identify and Resolve Radio/TV Interference Problems". This booklet is available from the U.S.

Government Printing Office,
Washington, D.C. 20402.

Please specify stock number 004-000-00345-4 when ordering copies.

Notice: The changes or modifications not expressly approved by the party responsible for compliance could void the user's authority to operate the equipment.

2.9 Hearing Aid Compatibility (HAC)

This telephone system meets FCC and Industry Canada standards for Hearing Aid Compatibility.

2.10 FCC RF Radiation Exposure Statement

This equipment complies with FCC RF radiation exposure limits set forth for an uncontrolled environment. This equipment should be installed and operated with a minimum distance of 20 centimeters between the radiator and your body. This transmitter must not be co-located or operating in conjunction with any other antenna or transmitter. For hand held operation, this phone has been tested and meets the FCC RF exposure guidelines. Use of other accessories may not ensure compliance with FCC RF exposure guidelines.

3 Important

Take time to read this user manual before you use your phone. It contains important information and notes regarding your phone.

NOTICE: This product meets the applicable Industry Canada technical specifications.

The equipment must be installed using an acceptable method of connection. The customer should be aware that compliance with the above conditions may not prevent degradation of service in some situations.

Repairs to certified equipment should be made by an authorized Canadian maintenance facility designated by the supplier. Any repairs or alterations made by the user to this equipment, or equipment malfunctions, may give the telecommunications company cause to request the user to disconnect the equipment.

Users should ensure for their own protection that the electrical ground connections of the power utility, telephone lines and internal metallic water pipe systems, if present, are connected together. This precaution may be particularly important in rural areas. **CAUTION:** Users should not attempt to make such connections themselves, but should contact the appropriate electric inspection authority, or electrician, as appropriate.

NOTES: This equipment may not be used on coin service provided by the telephone company.

3.1 Power requirements

- This product requires an electrical supply of 100-240 volts AC. In case of power failure, the communication can be lost.
- The Electrical network is classified as hazardous. The only way to power down the charger is to unplug the power supply from the electrical outlet. Ensure that the electrical outlet is always easily accessible.
- The voltage on the network is classified as TNV-3 (Telecommunication Network Voltages), as defined in the standard UL 60950.

Warning

To avoid damage or malfunction:

- Do not allow the charging contacts or the battery to come into contact with metal objects.
- Do not open it as you could be exposed to high voltages.
- Do not allow the charger to come into contact with liquids.
- Never use any other battery than the one delivered with the product or recommended by Philips: risk of explosion.
- Always use the cables provided with the product.
- Handsfree activation could suddenly increase the volume in the earpiece to

a very high level: make sure the handset is not too close to your ear.

- This equipment is not designed to make emergency calls when the power fails. An alternative has to be made available to allow emergency calls.
- Do not expose the phone to excessive heat caused by heating equipment or direct sunlight.
- Do not drop your phone or allow objects to fall on your phone.
- Do not use any cleaning agents containing alcohol, ammonia, benzene, or abrasives as these may harm the set.
- Do not use the product in places where there are explosive hazards.
- Do not let small metal objects come into contact with the product. This can deteriorate audio quality and damage the product.
- Active mobile phones in the vicinity may cause interference.

About operating and storage temperatures:

- Operate in a place where temperature is always between 0 and 35° C (32 to 95° F).
- Store in a place where temperature is always between -20 and 70° C (-4 to 158° F).
- Battery life may be shortened in low temperature conditions.

3.2 Electric, Magnetic and Electromagnetic Fields (“EMF”)

1. Philips Royal Electronics manufactures and sells many consumer oriented products which usually, as with any electronic apparatus, have the ability to emit and receive electro magnetic signals.
2. One of Philips’ leading Business Principles is to take all necessary health and safety precautions for our products, to comply with all applicable legal requirements and to stay well within the EMF standards applicable at the time of producing the products.
3. Philips is committed to develop, produce and market products that cause no adverse health effects.
4. Philips confirms that if its products are handled properly for their intended use, they are safe to use according to scientific evidence available today.
5. Philips plays an active role in the development of international EMF and safety standards, enabling Philips to anticipate further developments in standardisation for early integration in its products.

3.3 Recycle your batteries

Do not dispose your rechargeable batteries. Call the toll free number 1-800-822-8837 to get instructions on how to recycle your batteries.

4 The RBRC® seal



The RBRC® Seal on the nickel metal hydride battery indicates that Philips Royal Electronics is voluntarily

participating in an industry program to collect and recycle these batteries at the end of their useful lives, when taken out of service within the United States and Canada.

The RBRC® program provides a convenient alternative to placing used nickel metal hydride batteries into the trash or municipal waste, which may be illegal in your area.

Philips’s participation in RBRC® makes it easy for you to drop off the spent battery at local retailers participating in the RBRC® program or at authorized Philips product service centers.

Please call 1-800-8-BATTERY for information on Ni-MH battery recycling and disposal bans/restrictions in your area. Philips’s involvement in this program is part of its commitment to protecting our environment and conserving natural resources.

RBRC® is a registered trademark of Rechargeable Battery Recycling Corporation.

4.1 Service Centers

US service center

Philips Accessories & Computer

Peripherals North America 1881 Route

46 WestLedgeWood, NJ 07852

Phone: (800) 233-8413

E-mail support:

<http://www.support.philips.com/support>

5 Your phone

Congratulations on your purchase and welcome to Philips!

To fully benefit from the support that Philips offers, register your product at www.philips.com/welcome.

5.1 What's in the box



Handset with belt clip

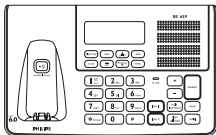

Base Station



Battery door

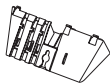

Bracket for wall mounting



2 AAA rechargeable batteries

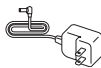

Power supply

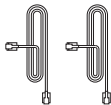

Line cords*



User manual



Guarantee



Do not return leaflet



Quick Start Guide

Note

* The black line cord is a 4-pin telephone line cord, and the gray line cord is a 2-pin telephone line cord. Use these as explained in 7.1 Connect the base station. In multihandset packs, you will find one or more additional handsets, chargers with power supply units and additional rechargeable batteries.

5.2 Overview of your handset

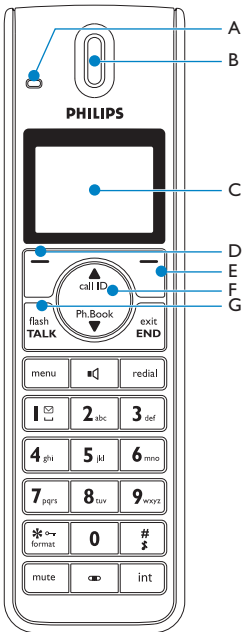

A Event LED

The event LED on your handset blinks when there is a new message recorded on your telephone answering machine. If you have subscribed to Caller Line Identification, the event LED also blinks when there is a new call, or a new voice mail message.

B Earpiece

C Display

See section 5.3 for an overview of the display icons.

D Select key

Press to receive an incoming call on Line 1, or to select Line 1 for making an outgoing call.

In a menu, selects the function displayed on the screen or go to the next lower level. Also used to confirm entries (for example, when setting date and time).

E Back/Clear key

Press to receive an incoming call on Line 2, or to select Line 2 for making an outgoing call.

When making an entry, press to clear (delete) a character or number, or long press to clear all.

When navigating menus, press to move to the previous higher menu level (**Back** is displayed).

F Navigation keys

In idle mode: Scroll up \uparrow call ID to access the Call log and scroll down \downarrow Ph.Book to access the Phonebook.

During a call: Scroll \oplus to increase or decrease earpiece and speaker volume.

Editing and entry: Move to the previous character \uparrow call ID or next character \downarrow Ph.Book.

In other modes: Scroll up \uparrow call ID and down \downarrow Ph.Book a menu list or go to the previous or next record in the Phonebook, Redial list, or Call log.

G Talk key

In idle mode: Make or answer an external call on the default line, or answer an incoming internal call.

During a call: Activate the flash function.

In other modes: Dial the selected number in the Phonebook, Redial list, or Call log on the default line.

H Hang-up/Exit key

In idle mode: Long press (5 seconds) to switch off the handset.

When the handset is switched off: Long press (1 second) to switch it on.

During a call: Hang up a call.

In other modes: Press to return to idle mode.

I Menu key

In idle mode: Go to the main menu.

J Redial key



Access the Redial list in idle mode.

K Loudspeaker key

In idle mode: Turn on the loudspeaker and dial the number. Answer an incoming call on the default line using handsfree mode.

During a call: Toggle the loudspeaker on/off.

L Number keys

Use to dial numbers and write characters. With key , a long press invites you to select a line, then dials your voice mail subscriber access number via the selected line. With keys  to , a long press invites you to select a line, then dials one of your direct memory access numbers via the selected line.

M */Keypad lock & Format key

In idle mode: Long press to lock/ unlock keypad.

Redialling or editing: Press to enter a “*”.*

Off hook: Long press to temporarily switch to tone (DTMF) dialling if using pulse.

During call log display: Toggles area code and long distance display on/off.

N #/Ringer on/off & Pause key

In idle mode: Long press to turn the ringer on/off.

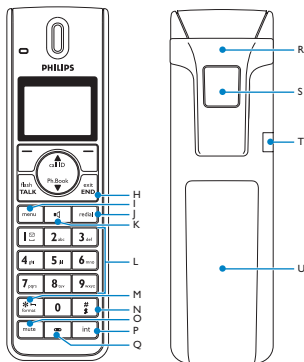

Dialling or editing: Long press to insert a pause (during pre-dialling) and short press to insert a “#”.

Editing: Short press to switch upper/lower case.

O Mute key

When off hook: Deactivate/activate the microphone.

P Call transfer key & Intercom key

In idle mode: Initiate an internal call.

During a call: Short press to hold the line and page another handset. Long press to set up a conference between an external call and two handsets.

Q Microphone

R Belt clip

S Loudspeaker (underneath the belt clip)

Warning

Handsfree activation can suddenly increase the volume of the earpiece to a

very high level. Make sure the handset is not too close to your ear.

T Headset jack

U Battery door

5.3 Display icons and Messages



Indicates that the battery is fully charged. This icon blinks during charge and when the battery is low.



When the icon is empty the battery is practically discharged.

Note

If **Warning Batt** flashes together with a blinking battery icon, batteries of the wrong type are installed in the handset. Replace with batteries of the correct type.



Blinks when there is an incoming call. Steady On during a call.



If you subscribe to voice mail service, blinks when there is new voice mail.



Blinks when there are new and missed calls in the call log records.



Appears when the alarm clock is activated. Blinks when the alarm time comes.



Appears when the loudspeaker is activated.



Appears when the ringer is off.



Steady on when the answering machine is on. Blinks when messages have been received by the answering machine; blinks rapidly when answering machine memory is full.



Indicates that the handset is registered and within range of the base station. Icon blinks when the handset is out of range or is searching for a base. Appears when using Line 1.



Appears when using Line 2.



L1 IN USE

Steady ON when another unit is using Line 1 (appears only in talk mode).

L1 HOLD

Steady on when Line 1 is on hold (appears only in talk mode).

L1 CALL

Steady on when there is a incoming call on Line 1 (appears only in talk mode).

L2 IN USE

Steady ON when another unit is using Line 2 (appears only in talk mode).

L2 HOLD

Steady on when Line 2 is on hold (appears only in talk mode).

L2 CALL

Steady on when there is a incoming call on Line 2 (appears only in talk mode).

Line 1/Select/OK

Line 1 selects Line 1.

Select appears when in menu mode. Press the key directly below to move to the next menu level or to confirm a selection.

OK appears to request confirmation of an operation. Press the key directly below to confirm.



Indicates that more options are available in a scroll list, or that you can adjust the volume.

Line 2/Back/Clear

Line 2 selects Line 2.

Back appears when in menu mode. Press the key directly below to return to the previous menu level.

Clear appears when making an entry. Press the key directly below to clear (delete) a character or number when making an entry. Long press to clear all.

5.4 Overview of the base station

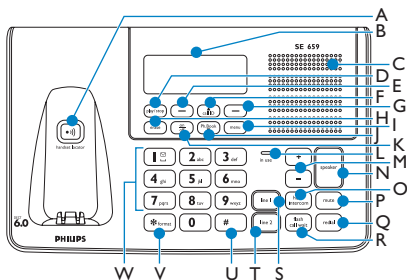

A Handset locator key

Locate handset.

Long press more than 3 seconds to start the registration procedure.

B Display

See 5.5 for an overview of the display.

C Speaker

D Play/Stop key

Play phone messages (the first message recorded will be played first). After pressing this key, select Line 1 or Line 2 using the soft keys. Voice prompts are played between messages and when all messages have been played.

Stop message playback.

E Previous/Select Key

During message playback: Go to the previous message.

In menu mode: Select the function displayed on the screen or go to the next lower level in a menu.

F Call log/Up key

In idle mode: Enter the call log.

In menu mode: Scroll up in the list.

G Back/Clear Key

During message playback: Go to the next message.

In menu mode: Go to the previous level in a menu.

H Erase Key

During message playback: Short press to delete the current message.

In idle mode: Long press to delete all old messages. After long pressing this key, select Line 1 or Line 2 using the soft keys.

I Menu key

Enter/exit the main menu.

J Phonebook/Down key

In idle mode: Enter the phonebook.

In menu mode: Scroll down in the list.

K On/Off Key

Short press to switch the answering machine on/off. After pressing this key, select Line 1 or Line 2 using the soft keys.

L Event LED

The event LED on the base blinks during handset locating. It is steady on when a handset has taken the line.

M Volume Keys

In idle mode: Increase or decrease the ring volume. Ring volume can be set separately for each of Line 1 and Line 2. During a conversation or during message playback: Increase or decrease the speaker volume.

N Speaker key

In idle mode: Pick up the first open line with the speaker on.

During a call: End the call. The speaker key LED blinks when receiving an incoming call. It is steady on when the base is in talk mode.

O Hold/Intercom key

In idle mode: Initiate an internal call. During a call: End the call. The speaker key LED blinks when receiving an incoming call. It is steady on when the base is in talk mode.

P Mute key

When off hook: Mute/Unmute the microphone.

Q Flash/Call waiting

Send a flash on the line. If there is an incoming call waiting, answer the call.

R Redial key

Access the Redial list.

S Line 1 key

In idle mode: Pick up Line 1 with the speaker on.

During a call: Release Line 1. If there is a current call on Line 2, pick up Line 1 and put the call on hold on Line 2.

T Line 2 key

In idle mode: Pick up Line 2 with the speaker on.

During a call: Release Line 2. If there is a current call on Line 1, pick up Line 2 and put the call on hold on Line 1.

U Hash key

Short press to enter a '#'.

Long press to enter a pause.

V Star/format key

Enter a '**'.
When viewing the call log, press to

change the number format. (See section 11.1.1 - "To choose the format for call log display.")

W Number keys

Short press to dial numbers.

Long press keys  to  to dial a direct access memory number.

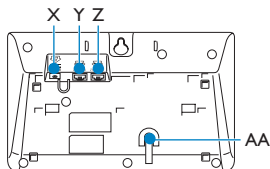

X DC IN 6V jack

Y TEL LINE 2 phone jack

Z TEL LINE 1/2 phone jack

AA Microphone (at the bottom front of the base station)

5.5 Base station display

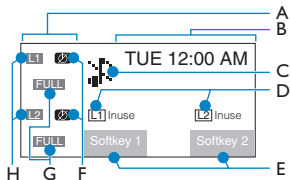

A Sub-screen display area

Shows answering machine status. See below.

B Main display area

In idle mode: Displays the time and date or new events.

In menu mode: Displays the options in the menu.

C Ringer Off Icon

Turns on when the ringer volume is set to zero. The small numerals "1" and "2" show which line(s) have ringer volume set to zero.

D L1 and L2 in Main Display Area

L1 is for Line 1 and L2 is for Line 2.

These icons blink when the line is receiving a call.

They are steady on when:

- The line is off-hook.
- The line is in external talk mode.
- Viewing call log of the line.
- The line is in hold mode or in use by handset.
- The line is set to Call barring on.

E Soft keys

Soft key 1 is activated by the **Select/OK** key. Soft key 2 is activated by the **Back/Clear** key.

F Answering Machine Counters

Displays  steady on when the answering machine of the line is set to off.

Displays blinking "R" when the answering machine of the line is in handset remote control mode.

Displays blinking "A" when the answering machine of the line is in auto answering mode.

G Message Counter

Shows the number of the messages in answering machine for the line. Blinks when there are new messages.

The **FULL** icon comes on when message memory of the line is full, but only when there are no new messages.

H L1 and L2 in the Sub-screen Display Area

L1 is for Line 1 and L2 is for Line 2.

These icons appear at all times.

6 Conventions Used in this Manual

This manual uses the following conventions.

• **Bold text**

Bold text is used for messages and instructions that are shown on the handset or base display screen.

• **Handset and Base Station Keys**

Except where indicated otherwise, basic operation is the same for both the

handset and base station of this product. However, for some functions the keys used on the handset and base station have different shapes or different lettering.

The procedures in this manual use the handset key icons. This table shows the corresponding keys for the base station. Refer to it when needed.

Key on Handset	Key on Base Station
call ID Ph.Book	call ID Ph.Book
	Left key
	Right key
int	hold intercom
*format	*format
#	#

These keys are used to access the main menu and utilize functions such as redial and caller ID.

For details, see 5.2 and 5.4.

• Terminology

When a procedure applies equally to the handset and the base station, the word “unit” is used to indicate both.

• Scrolling

“Scroll ” means to use the call ID and Ph.Book keys on the handset or the call ID and Ph.Book keys on the base station to scroll through a menu or list on the display screen.

Note: See Section 5 for detailed descriptions of the functions and use of the keys of the handset and base station.

7 Getting started

7.1 Connect the base station

- 1 Place the base station in a central location near the telephone line socket and electricity socket.
- 2 Connect the line cord(s) and the power cable to their corresponding connectors at the back of the base station.

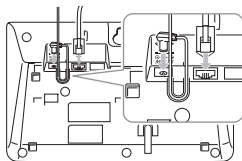

Note

For 2 line subscriptions, connect the 4-pin telephone line cord (the black cord) to the black TEL LINE 1/2 phone jack and to the telephone wall jack for line 1.

Connect the second telephone line cord (the gray cord) to the gray TEL LINE 2 phone jack and to the telephone wall jack for line 2.

If the two phone lines are on one modular wall jack, connect only the 4-pin telephone line cord (the black cord) to the black TEL LINE 1/2 phone jack and to the telephone wall jack. (Do not connect anything to the gray TEL LINE 2 phone jack.)

- 3 Connect the other end of each of the line cords to its socket.

- 4** Connect the power cable to the power outlet.

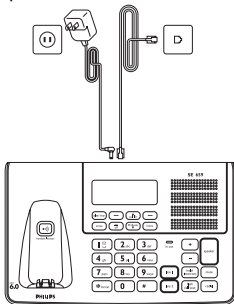

Note

Line adaptors may not be attached to the line cords. In this case, you have to connect line adaptors to the line cords first before plugging the line cords into the line sockets.

Warning

Avoid placing the base station too close to large metal objects such as filing cabinets, radiators or electrical appliances. This can impair the range and sound quality. Buildings with thick internal and external walls may impair transmission of signals to and from the base.

Warning

Power is applied when the power adaptor is plugged into the unit and connected to the electricity socket. The only way to power down the unit is to unplug the power adaptor from the electricity socket. Therefore, ensure that the electricity socket is easily accessible.

The power adaptor and telephone line cord(s) have to be connected correctly, as incorrect connection could damage the unit. Always use the telephone line cord(s) supplied with the unit. Otherwise, you may not get a dial tone.

7.2 Wall mounting the base

The base is designed to support wall mounting. To wall mount the base, follow the instructions below.

- 1** Attach the bracket to the base station as shown below.

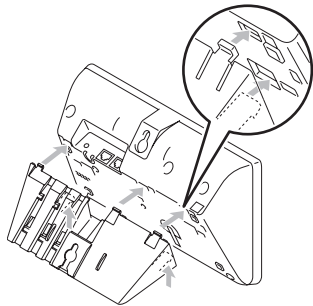

- 2** Use the pedestal wall mounting to plug your base station.

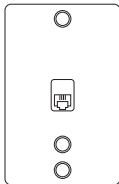

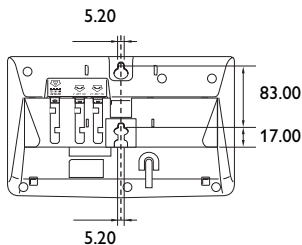

7.3 Install your phone

Before using the handset, the batteries have to be installed and fully charged.

Warning

When the batteries are inserted for the first time, the unit will not be able to start normally due to the low battery. You must charge the batteries on the base station before you can use the handset.

7.3.1 Install battery

Warning

Always use AAA rechargeable batteries supplied with your unit. If alkaline batteries are used instead of rechargeable batteries, “**Warning Batt**” will show on the display and the battery icon will blink quickly.

- 1 Slide out the battery cover.

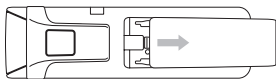

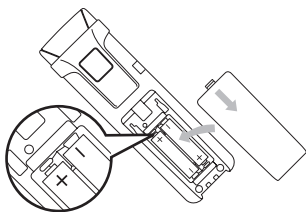

- 2 Place the batteries in the correct polarity as indicated and replace the cover.



7.3.2 Charge battery

Warning

The handset must be charged for at least 24 hours before using it for the first time. When the battery level becomes low, the low battery sensor warns you by blinking the battery icon. If this occurs during a conversation, an alert tone sounds to inform you that the battery is low. If the battery level becomes exceedingly low, the phone automatically switches off shortly after the icon starts blinking and any function in progress will not be saved.

- 1 Place the handset on the charging cradle of the base station. A beep is emitted if the handset is placed correctly.
- 2 The battery icon  on the display blinks during charge.
- 3 The battery icon  becomes steady when the handset is fully charged.

Note

Optimal battery life is reached after 3 cycles of complete charging (over 15

hours) and discharging, allowing approximately 12 hours of talk-time and 150 hours of stand-by time.

The indoor and outdoor range of the phone is up to 50 metres and 300 metres respectively. When the handset moves beyond the operation range, the antenna icon will blink.

*** Tip**

When you reach the range limit the conversation may become crackly. Move closer to the base.

7.4 Remove/Attach belt clip

A belt clip allows you to carry your handset on your belt.

- 1 To remove the belt clip, simply pull the clip away from the handset.
- 2 To attach the belt clip to your handset, fit the tabs on the belt clip into the slots at the back of the handset and push into place.



7.5 Install optional headset

Your phone may be used with an optional headset (not included in the box). To use this feature, insert the headset plug into the headset jack. Your phone is ready for hands-free conversations.

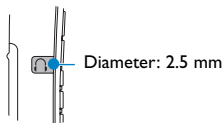

7.6 Power up

On the base, the screen below is shown during power up.

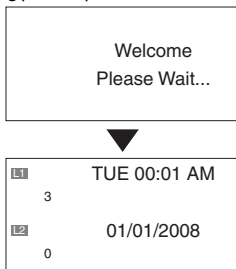

The handset will start searching and the backlight will turn on.

Handset screen

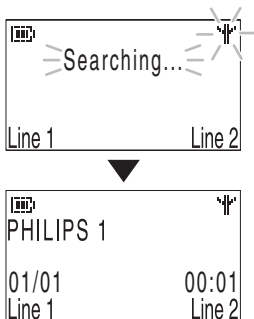

The display will show the word “Searching” and Antenna icon flashing until it locks onto its subscribed base. Then the display shows the standby display.







7.7 Using multipacks



If you have purchased a multipack you will have additional handsets, chargers, power adaptors and AAA rechargeable batteries.



- 1** Plug the chargers into a power socket.
- 2** Install the batteries supplied into the handsets.
- 3** Place the handsets on the chargers to charge the batteries.

7.8 Handset menu structure

The SE659 has six menus as shown in the following table.

	Menu Name	Icon
1	Phonebook	
2	Personal Settings	
3	Clock and Alarm	
4	Advanced Settings	
5	Network Services	
6	Answer Machine	

Press the menu key  to enter menu mode. Use navigation keys  to navigate within the menus and all submenus.

Press  **Select** to enter the next lower menu level. Press  **Back** to go to the previous menu level.

The charts below show the menu trees of your phone.

Phonebook

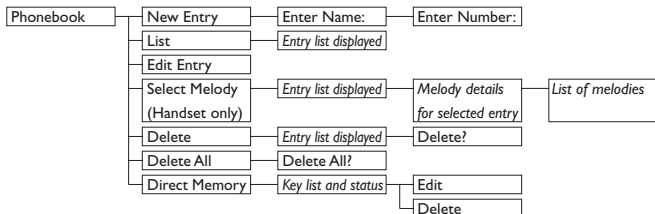

Personal Settings

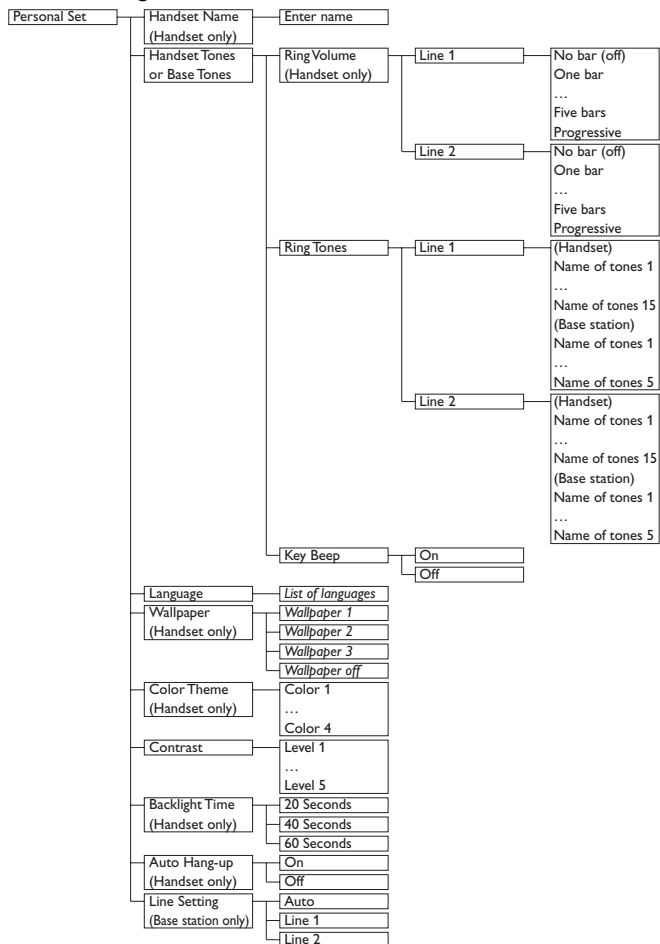

Clock and Alarm

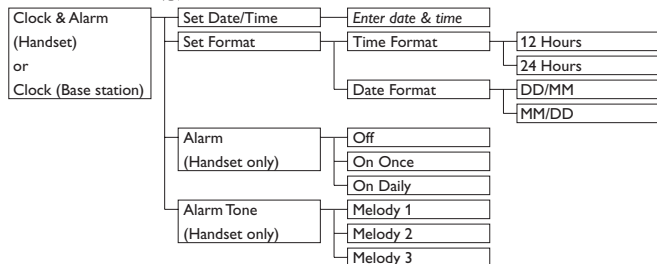

Advanced Settings (Handset only)

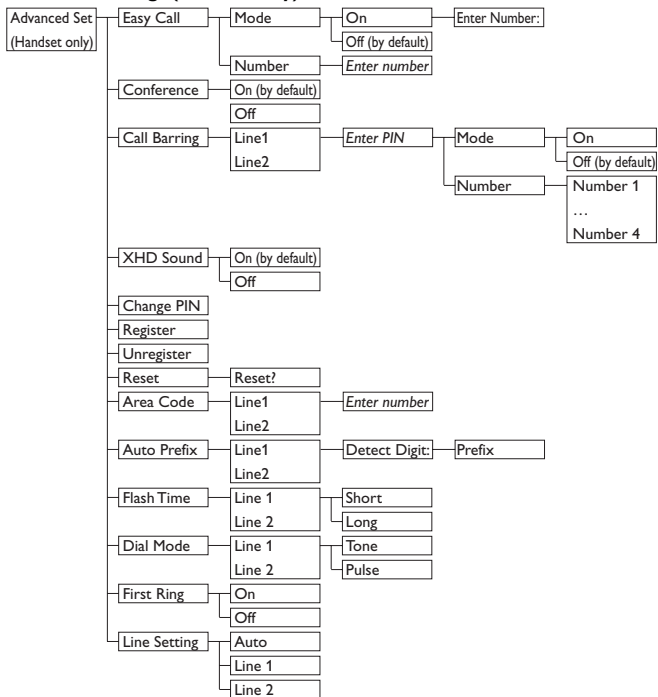

Network Services (Handset only)

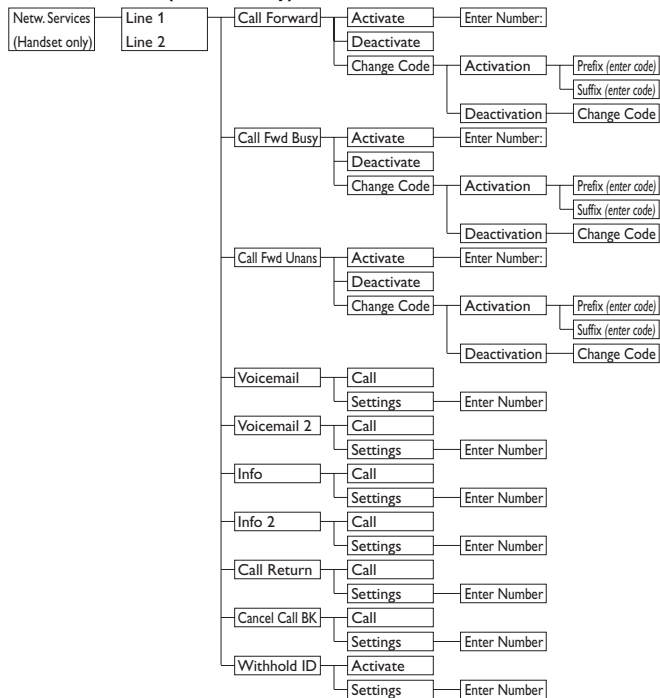

Answer Machine

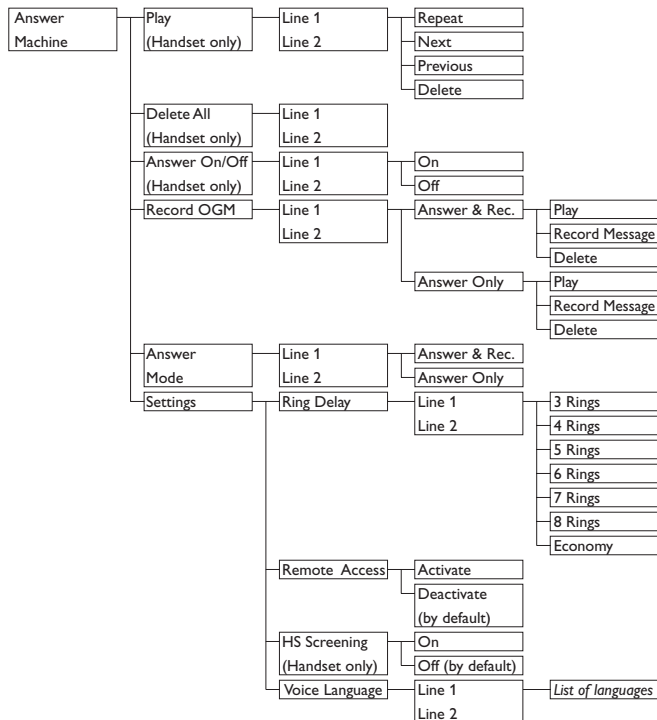





8 Using your phone



8.1 Make a call

8.1.1 Predialling

1 Enter the number. (A maximum of 24 digits including * and # are allowed. Press  **Clear** to delete the last digit. Or long press to delete all.)

2 From the handset: Press . The line selection menu appears and the default line is highlighted. If you want to switch to the other line, scroll . To start the call, press  or  **Select** (or press  to start in speaker mode).

- The call is initiated on the highlighted line.



From the base: Press  to call from the default line. When **Auto** is selected as the line setting, the base will automatically select a free line. To call from a particular line, press  or .

- The call is initiated.

Note



For the line setting on the base station, see section 12.9.

8.1.2 Direct dialling

1 From the handset: Pick up the handset. To call from the default line, press  (or press  to start a call in speaker mode). To call

from a particular line, press 



Line 1 or  **Line 2**.

From the base: Press  to call from the default line. To call from a particular line, press  or .

2 Dial the number.

- The call is initiated.





Note

If **Auto** is selected as the line setting, the phone will automatically select a free line when you press  or  on the handset or  on the base. For the line setting, see section 13.14 for the handset and section 12.9 for the base station.



8.1.3 Call from redial list

1 Press  in idle mode.

2 Scroll  to an entry in the redial list.

3 From the handset: Press . The line selection menu appears and the default line is highlighted. If you want to switch to the other line, scroll . To start the call, press  or  **Select** (or press  to start in speaker mode).

- The call is initiated on the highlighted line.

From the base: Press  to call from the default line. When **Auto** is selected as the line setting, the base will automatically select a free line. To call from a particular line, press  or .

- The call is initiated.

Note

The handset(s) and base station each have their own redial list.

8.1.4 Call from the call log

Note





- The call log is shared between handset(s) and the base station.
- You need to subscribe to Caller Line Identification service to be able to see the caller's number or name in the call log. See section 11.1 - "Access the Call log".

1 Press  in idle mode.



Note

If the list is already empty, then "List Empty" is displayed.

2 Scroll  to an entry in the call list.

3 From the handset: Press . The line selection menu appears and the default line is highlighted. If you want to switch to the other line, scroll . To start the call, press  or  **Select** (or press  to start in speaker mode).

- The call is initiated on the highlighted line.

From the base: Press  to call from the default line. When **Auto** is selected as the line setting, the base will automatically select a free line. To call from a particular line, press  or .

- The call is initiated.





Note

For the line setting on the base station, see section 12.9.



8.1.5 Call from the phonebook

1 Press  in idle mode.

2 Scroll  to a phonebook entry.

3 From the handset: Press . The line selection menu appears and the default line is highlighted. If you want to switch to the other line, scroll . To start the call, press  or  **Select** (or press  to start in speaker mode).

- The call is initiated on the highlighted line.

From the base: Press  to call from the default line. When **Auto** is selected as the line setting, the base will automatically select a free line. To call from a particular line, press  or .

- The call is initiated.





Note



For the line setting on the base station, see section 12.9.

8.1.6 Call from the phonebook while already on the phone



1 While on the phone, press **Option** soft key and then  **Select** to enter the phonebook name list.

2 Scroll  to a phonebook entry.

3 From the handset: To call from the default line, press  (or press  to start a call in speaker mode). To call from a particular line, press  **Line 1** or  **Line 2**.

From the base: Press  to call from the default line. To call from a particular line, press  or .



Note

If **Auto** is selected as the line setting, the phone will automatically select a free line when you press  or  on the

handset or  on the base. For the line setting, see section 13.14 for the handset and section 12.9 for the base station.

8.1.7 Call using Direct Access

Memory

Press a number key  to  for more than 2 seconds. This invites you to select a line, then dials a stored direct access memory number on the desired line.

Note

- The handset(s) and base station each have their own direct access memories.
- See section 10.7 for instructions on how to store, edit, and delete direct access memory numbers.

8.1.8 Enter a Dialing Pause

Long press key  to enter a pause in the dialling sequence. The pause is indicated by a P.

8.2 Answer a call

Danger





When the handset rings during an incoming call, please do not hold the handset too close to your ear as the volume of the ringing tone may damage your hearing.

When the phone rings, the L1 (or L2) indicator and **L1 CALL** (or **L2 CALL**) icon appear to indicate the incoming call line. To answer, press the appropriate soft key on the handset ( **Line 1** or

 **Line 2**), or   on the base station.)

- The call is established.

Note

- When **Auto** is selected as the line setting, you can accept incoming calls on either line by pressing  or  on the handset, or  on the base station. When Line 1 or Line 2 is selected as the line setting, you can use these keys to accept calls on the selected line, but you must use the **Line 1** or **Line 2** soft keys on the handset or   on the base station to accept calls on the other line.
- Incoming call has priority over other events. Whenever there is an incoming call, other status in progress such as phone setting, menu navigation, etc will be aborted.

8.2.1 Handsfree answering with handset

Danger

Handsfree activation can suddenly increase the volume in the earpiece to a very high level. Make sure the handset is not too close to your ear.

When the phone rings, and current default line is the incoming call line, press  on the handset.



- The loudspeaker is activated on the handset.

8.3 Answer a call on the other line

You can put the current call on hold and accept an incoming call on the other line.

- 1 When there is an incoming call from the other line, the earpiece will emit a beep tone to inform you; press the other line key on the handset.
 - The call is established on the second line.
- 2 To switch back to the first caller, either hang up the second line, or place it on hold and press the first line key to resume talking with the first caller.

8.4 End a call

To end a conversation, press  on the handset or  key on the base.

- The call ends.

Tip

When auto hang-up is on, you can simply place the handset back to its base station or charger to end the call. This feature is activated by default.





Note

The call duration (MM:SS) will be displayed on the handset screen for about 5 seconds.







8.5 Using the Redial list

The redial list stores the last 10 numbers dialed. A maximum of 32 digits can be displayed for each entry.





8.5.1 Access Redial list



- 1 Press  to go to the redial list and scroll  to browse the redial list.
 - The last number dialed will appear first in the redial list. If the redial number matches a phonebook entry, the name will be displayed instead.
 - 2 To open the redial list options, press  **Menu**.
-  **Note**
Press  **Back** to return to the previous menu.

8.5.2 View redial number details



- 1 Press  in idle mode, scroll  to select an entry and press  **Menu**.
- 2 **View** is highlighted on the screen; press  **Select** to display information about the number dialed.
- 3 Press  **Next** to display further information. Afterward, you can press  **Prev.** to return to the former screen. After viewing, press  **Back** to return to previous menu levels.

8.5.3 Save a redial number into the phonebook







- 1 Press  in idle mode, scroll  to select an entry and press  **Menu**.
- 2 **View** is highlighted on the screen. Scroll  to **Save Number** and press  **Select**.

- 3** **Enter Name** is displayed. Enter the name of the contact (maximum 14 characters) and press  **OK**.
- 4** **Enter Number** is displayed and the selected number from the redial list appears in the number field. At this time you can edit the number if you wish to.
- 5** Press  **OK**. The screen returns to the redial list.

Note

Press  **Clear** to delete the last digit or character entered. Long press  **Clear** to clear the entire entry.





8.5.4 Delete a redial number

- 1** Press  in idle mode, scroll  to select an entry and press  **Menu**.
- 2** Scroll  to **Delete** and press  **Select**.
- 3** **Delete?** is displayed on the screen.
- 4** Press  **OK** to confirm deletion.
 - A validation tone is emitted.

Note

Press  **Back** to discard the deletion. The screen returns to the redial list.

8.5.5 Delete all redial numbers

- 1** Press  in idle mode, and press  **Menu**
- 2** Scroll  to **Delete All** and press  **Select**.
- 3** **Delete All?** is displayed on the screen.
- 4** Press  **OK** to confirm deletion.
 - A validation tone is emitted.