

3.4 Overview of the base station

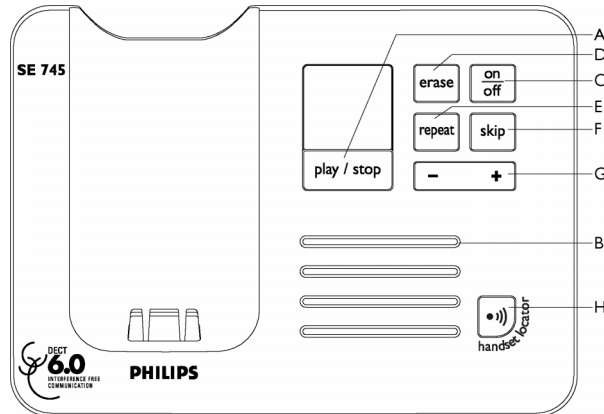

A Play/Stop key

Play phone messages (the first recorded will be played first).

Stop message playback.

B LED indicator

Blinking: Indicates number of new messages.

Steady: Indicates number of old messages.

2 bars flashing: Indicates that there is no more memory left.

Indicates the volume level (L0 - L9) when  is pressed.

Indicates the current message number during playback.

C On/Off key

In idle mode, *short press* to switch on/off the answering machine. During message playback, *long press* to switch off the answering machine.

D Erase key

Delete current message during message playback.

Long press to delete all messages when the answering machine is in idle mode (unread messages will not be deleted).

E Repeat key

Go to previous message if pressed within 1 second of current message playback.

Replay current message if pressed after 1 second of current message playback.

F Skip key

Skip to the next message during message playback.

G Volume keys

Increase/Decrease speaker volume during message playback.

There are 9 volume levels.

H Handset locator key

Locate the handset.

Long press to start registration procedure.

4 Getting started

4.1 Connect the base station

- Place the base station in a central location near the telephone line socket and electricity socket.

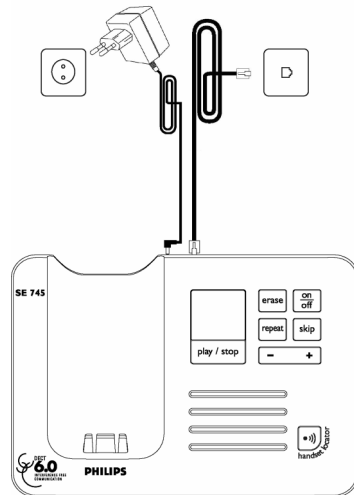

4.1.1 Install the base support

- Place the base station face down so that you can see the bottom of the base station.
- Attach the base support to your base station by fitting the tabs of the base support into the corresponding slots on the base unit.



- Push into place until a click sound is heard.

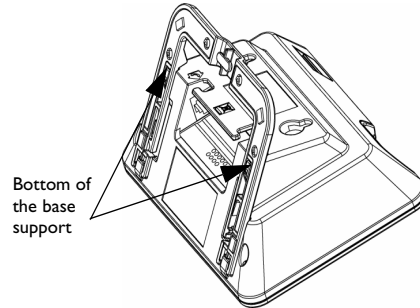

- To remove, simply pull the base support away from the base unit.

4.1.2 Connect the line cord and power cable

- Connect the line cord and the power cable to their corresponding connectors at the bottom of the base station as shown.

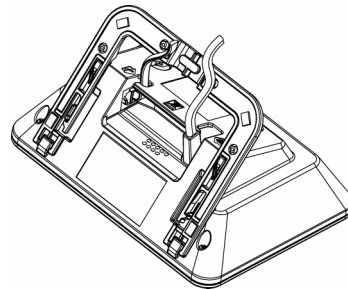

- Connect the other end of the line cord to the telephone line socket and the other end of the power cable to the electricity socket.

Note

The line adaptor may not be attached to the line cord. In this case, you have to connect the line adaptor to the line cord first before plugging the line cord to the line socket.

Warning

Avoid placing the base station too close to large metal objects such as filing cabinets, radiators or electrical appliances. This can impair the range and sound quality. Buildings with thick internal and external walls may impair transmission of signals to and from the base.

Warning

The base station does not have an ON/OFF switch. Power is applied when the power adaptor

Getting started

is plugged into the unit and connected to the electricity socket. The only way to power down the unit is to unplug the power adaptor from the electricity socket. Therefore, ensure that the electricity socket is easily accessible.

The power adaptor and telephone line cord have to be connected correctly, as incorrect connection could damage the unit.

Always use the telephone line cord supplied with the unit. Otherwise, you may not get a dial tone.

4.2 Install your phone

Before using the handset, the batteries have to be installed and fully charged.

4.2.1 Install battery

⚠ Warning

Always use AAA rechargeable batteries supplied with your unit. There could be risk of battery leakage if you use alkaline batteries or other battery types.

- 1 Slide out the battery cover.

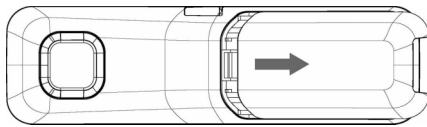

- 2 Place the batteries in the correct polarity as indicated and replace the cover.

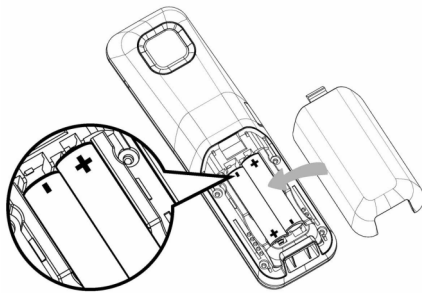

4.2.2 Charge battery



⚠ Warning

The handset must be charged for at least 24 hours before using it for the first time.

Getting started

When the battery level becomes low, an empty battery icon is displayed on the screen.

If the battery level becomes exceedingly low, the phone automatically switches off and any function in progress will not be saved.

- 1 Place the handset on the charging cradle of the base station. A melody is emitted if the handset is placed correctly.
- 2 The battery icon  on the display blinks during charge.
- 3 The battery icon  becomes steady when the handset is fully charged.

ⓘ Note

Optimal battery life is reached after 3 cycles of complete charging (over 15 hours) and discharging, allowing approximately 12 hours of talk-time and 150 hours of stand-by time.

4.3 Welcome mode







ⓘ Note

Depending on your country, the WELCOME screen may not appear. In this case, you are not required to select your country/operator/language settings.

⚠ Warning

You cannot make outgoing calls or receive incoming calls without first defining your country selection.

Before you first use your handset, you need to configure it according to the country of use. After charging it for a few minutes, the word WELCOME appears in various languages. Follow these steps to configure your phone:



- 1 Scroll  to the word WELCOME in your preferred language and press  SELECT to confirm your selection.
- 2 Scroll  to your country.
- 3 Press  SELECT to confirm your selection.
- 4 Press  to your operator (if necessary).
- 5 Press  SELECT again to confirm your selection.

- The default line settings and menu language for the selected country will be automatically configured.

- To set date/time, see "Set Date and Time" on page 26.

Your phone is now ready for use.

4.4 Menu structure

The table below describes the menu tree of your phone. Press left soft key  **MENU** in idle mode to enter each option. Use navigation keys  to navigate within the menus.

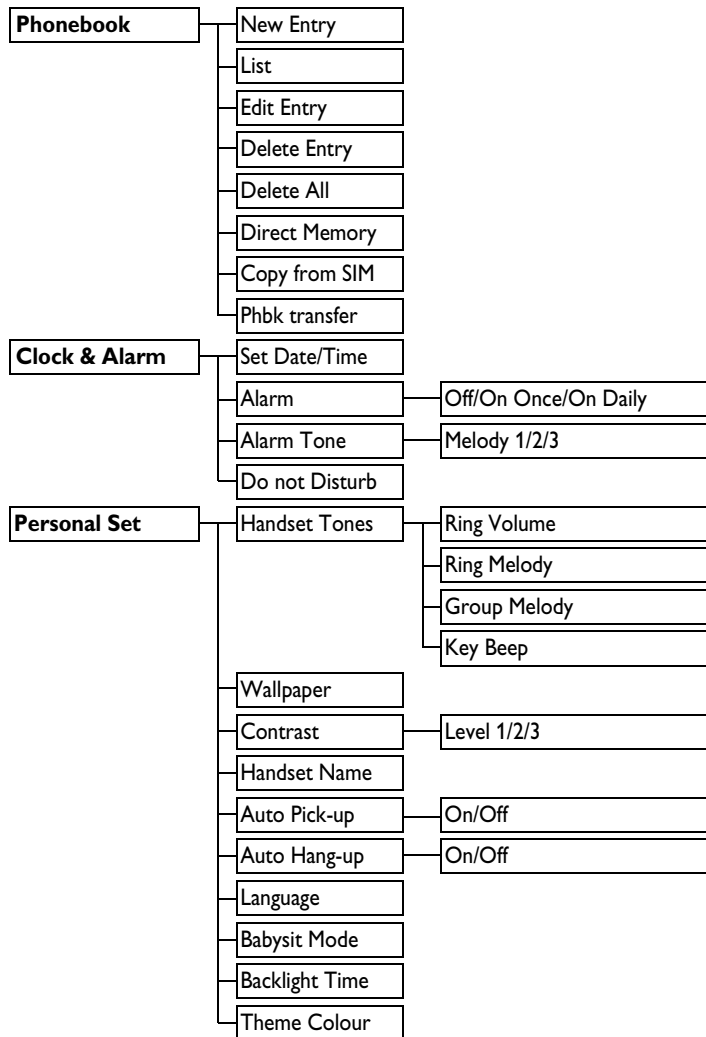

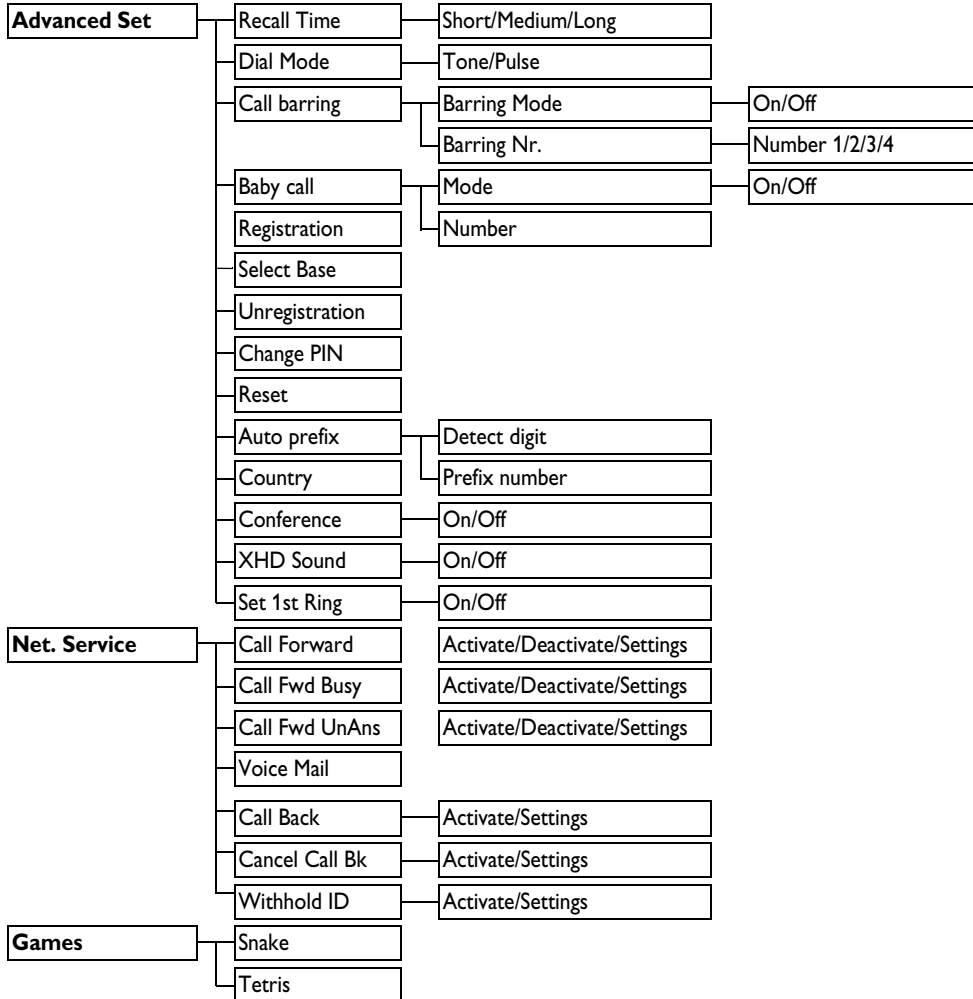

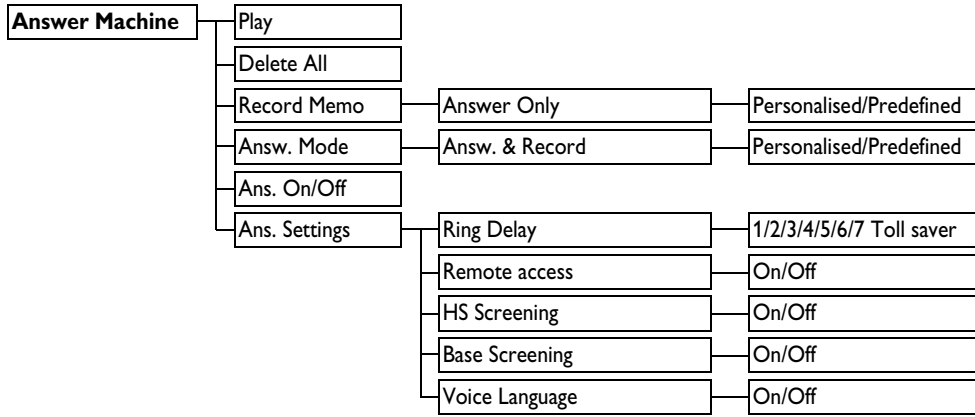

5 Using your phone

5.1 Make a call

5.1.1 Predialling

- 1 Dial the number (maximum 24 digits).
- 2 Press  key.
 - *The call is initiated.*



* Tip

You may insert a prefix number to the beginning of your predial number, see “Set Auto Prefix” on page 33 for more information.

5.1.2 Direct dialling

- 1 Press  key to take the line.
- 2 Dial the number.
 - *The call is initiated.*





5.1.3 Call from redial list

- 1 Press  **REDIAL** key in idle mode.
- 2 Scroll  to an entry in the redial list.
- 3 Press  key.
 - *The call is initiated.*

* Tip

The handset stores the last 20 numbers dialed. The last number dialed will appear first in the redial list. If the redial number matches a phonebook entry, the name will be displayed instead.

5.1.4 Call from the call log



- 1 Press  in idle mode.
- 2 Scroll  to **Call List** or **Answ. Machine** and press  **SELECT** to enter the respective sub-menus.
- 3 Scroll  to an entry.
- 4 Press  key.
 - *The call is initiated.*

ⓘ Note



You need to subscribe to Caller Line Identification service to be able to see the caller's

number or name in the call log (see “Access Call log” on page 24).

5.1.5 Call from the phonebook

- 1 Press  in idle mode.
- 2 Scroll  to a phonebook entry.
- 3 Press  key.
 - *The call is initiated.*

* Tip

Instead of scrolling  to browse the phonebook entries, you can press the numeric key corresponding to the first letter of the entry you wish to locate. For example, pressing  will show the entries starting with A. Pressing  again will show the entries starting with B, etc...

5.2 Answer a call

When the phone rings, press  key.

- *The call is established.*

ⓘ Note

Incoming call has priority over other events. Whenever there is an incoming call, other status in progress such as phone setting, menu navigation, etc will be aborted.

* Tip

If **AUTO ANSWER** mode (see “Activate / Deactivate Auto Pick-up” on page 29) is activated, you can simply lift up the handset from its base station to answer the call. This feature is deactivated by default.

⚠ Danger

When the handset rings during an incoming call, please do not hold the handset too close to your ear, as the volume of the ringing tone may damage your hearing.

5.2.1 Handsfree answering

When the phone rings, press  key.

- *The handset loudspeaker is activated.*

⚠ Danger

Handsfree activation can suddenly increase the volume in the earpiece to a very high level. Make sure the handset is not too close to your ear.

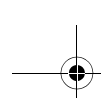

5.3 End a call

To end a conversation, press  key.

- *The call ends.*

Tip

If **Auto Hang-up** mode is activated (see “Activate /Deactivate Auto Hang-up” on page 29) , you can simply place the handset back to its base station to end the call. This feature is activated by default.

Note

The call duration (HH-MM-SS) will be displayed on the handset screen for about 5 seconds. Press  **BACK** to return to idle mode.

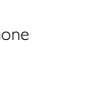
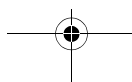
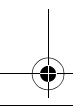
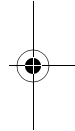
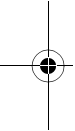

6 Use more of your phone

6.1 Switch the handset on/off

Press and hold  key for 3 seconds to switch off the handset in idle mode.





Short press  key to switch on the handset.

6.2 Keypad lock/unlock







Press and hold  key for 2 seconds to lock/unlock the keypad in idle mode.





6.3 Text or number entry

When you select a field in which you can enter text, you can enter the letters that are printed on the keys by pressing the relevant key once or several times. For example, to enter the name "PETER":

- 1 Press  once: **P**
- 2 Press  twice: **PE**
- 3 Press  once: **PET**
- 4 Press  twice: **PETE**
- 5 Press  three times: **PETER**

The table below gives you the character assignment during text or number entry:

Keys	Assigned characters
	space 1 @ _ # = < > () & € £ \$ ¥ [] { } ¢ §
	a b c 2 à ä ç å æ
	d e f 3 è é Δ Φ
	g h i 4 ï î Γ
	j k l 5 Λ
	m n o 6 ñ ò ö
	p q r s 7 β Π Θ Σ

	t u v 8 ù ü
	w x y z 9 ø Ω Ξ Ψ
	. 0 , / ; " ' ! ; ? ; * + - % \ ^ _
	Long press to switch between upper and lower case.
	*

* Tip

Press  **BACK** to delete the last digit or character entered.

6.4 Call in progress



Some options are available to you during a call. The available options are:

6.4.1 Adjust earpiece volume

During a call, press  to select from **Volume 1** to **Volume 5**.

6.4.2 Mute/Unmute microphone



When the microphone is muted, your correspondent cannot hear you.

- 1 During a call, press  **MUTE** to turn off the microphone.
- 2 Press  **UNMUTE** to turn on the microphone.

6.4.3 Activate/Deactivate loudspeaker mode

⚠ Danger

Handsfree activation can suddenly increase the volume in the earpiece to a very high level. Make sure the handset is not too close to your ear.

- 1 During a call, press  key to activate the loudspeaker mode.
- 2 Press  key again to return to normal mode.

6.4.4 Adjust loudspeaker volume

During a call, press  to select from **Volume 1** to **Volume 5**.

6.4.5 Initiate a second call (subscription dependent)

During a call, press  **OPTION** and select **Init. 2ND Call** to put the current call on hold and initiate a second external call.







6.4.6 Consult phonebook

During a call, press  **OPTION** and select **Phonebook** to access and review phonebook entries.



Press  on the selected phonebook entry, the corresponding number will be dialed.

6.4.7 Activate/deactive XHD Sound mode

XHD Sound mode is an exclusive feature making your phone conversations sounding just like real-life conversations. When activated, the XHD Sound mode transmits with high fidelity all the emotions of the call, as if your correspondent was talking next to you.

- 1 During a call, press  **OPTION**, scroll  to **XHD Sound On** and press  **SELECT** to activate.
- 2 To deactivate, press  **OPTION**, scroll  to **XHD Sound Off** and press  **SELECT**.







6.4.8 Transfer call (subscription dependent)



- 1 During a call, press  **OPTION**, scroll  to **Call Transfer** and press  **SELECT**.
 - The screen shows **R4**.
- 2 Enter the phone number that you want to transfer your incoming calls to.
 - The call is transferred.

6.5 Call waiting

If you have subscribed to Call Waiting service, the earpiece will emit a beep tone to inform you that there is a second incoming call. The number or name of the second caller will also be displayed on your phone if you have subscribed to Caller Line Identification service (CLI). Please contact your network provider for more information on this service.

When you receive a second incoming call while on the phone, you can carry out the following operations:

 + 	Put the current call on hold and answer the second call.
 + 	End the current call and answer the second call.
 + 	Reject the second call and continue with your current call.



Alternatively, when there is a second incoming call, press  **OPTION**, scroll  to **Accept & Hold**, **Accept & End** or **Reject CW** and press  **OK**.

The above operations may be different according to your network.





6.6 Caller Line Identification

Caller Line Identification (CLI) is a special service that you may subscribe from your network operator. If you have subscribed to CLI service, the identity of the caller (caller's number or name) will be displayed on your handset during an incoming call. If you have not subscribed to this service, or if the caller has chosen to withhold the number, the identity of the caller will not be displayed. Please contact your network provider for more information on this service.



6.7 Using your Phonebook

Your phone can store up to 250 phonebook memories, including 10 direct access memories ( to ). Each phonebook entry can have a maximum of 24 digits for the phone number and 14 characters for name.









6.7.1 Access phonebook

- 1 Press **pbk** in idle mode and scroll  to browse the phonebook.
 - The phonebook entries are listed in alphabetical order.
- 2 To view the details of a phonebook entry, scroll  to the phonebook entry and press  **VIEW**.
- 2 To dial a number from the phonebook, scroll  to the phonebook entry and press  **TALK**.

* Tip

Instead of scrolling  to browse the phonebook entries, you can press the numeric key corresponding to the first letter of the entry you wish to locate. For example, pressing  will show the entries starting with A. Pressing  again will show the entries starting with B, etc...

6.7.2 Store a contact in the phonebook

- 1 Press  **MENU** in idle mode, scroll  to **Phonebook** and press  **SELECT**, press  **SELECT** to enter **New Entry**.
- 2 Enter the name of the contact (maximum 14 characters) and press  **OK**.
- 3 Enter the phone number (maximum 24 digits) and press  **OK**.
- 4 Scroll  to choose a group (<No Group>, <Group A>, <Group B>, <Group C>) and press  **SELECT**.
 - A validation tone is emitted.













ⓘ Note

You can assign individual contacts to specific groups of your choice. For example, Group A contains phone numbers of all your co-workers. You can also assign a specific ring melody to that group (see "Set the Group Melody" on page 28). If you have subscribed to Caller Line Identification service from your network provider, every time someone from that group calls you, you will hear the designated ringtone for that group.









* Tip

You cannot store a new phonebook entry when the memory is full. In this case, you have to delete existing entries to make space for new entries.







6.7.3 Modify a phonebook entry

- 1 Press  **MENU** in idle mode, scroll  to **Phonebook** and press  **SELECT**, scroll  to **Edit Entry** and press  **SELECT**.
- 2 Scroll  to select an entry you wish to edit and press  **SELECT**.
- 3 Press  **CLEAR** to erase the letters one by one, enter the name and press  **OK**.
- 4 Press  **CLEAR** to erase the digits one by one, enter the phone number and press  **OK**.
- 5 Scroll  to choose a group (<No Group>, <Group A>, <Group B>, <Group C>) and press  **SELECT**.
 - A validation tone is emitted.



6.7.4 Delete a phonebook entry

- 1 Press  **MENU** in idle mode, scroll  to **Phonebook** and press  **SELECT**, scroll  to **Delete Entry** and press  **SELECT**.
- 2 Scroll  to select an entry you wish to delete and press  **SELECT**.
- 3 Press  **OK** to confirm.
 - A validation tone is emitted.

6.7.5 Delete the phonebook list

- 1 Press  **MENU** in idle mode, scroll  to **Phonebook** and press  **SELECT**, scroll  to **Delete All** and press  **SELECT**.
- 2 Press  **OK** to confirm.
 - A validation tone is emitted.

6.7.6 Direct Access Memory

You can store up to 10 direct access memories (Keys  to ). A long press on the keys in idle mode will automatically dial the stored phone number.

6.7.6.1 Store Direct Access Memory

- 1 Press **MENU** in idle mode, scroll \uparrow/\downarrow to **Phonebook** and press **SELECT**, scroll \uparrow/\downarrow to **Direct Memory** and press **SELECT**.
- 2 Scroll \uparrow/\downarrow to select a key (Keys **0** to **9**) and press **VIEW**.
 - The stored number is displayed (if any).
- 3 Press **SELECT** to display the menu options.
- 4 Press **SELECT** again to select **Add**.
- 5 Scroll \uparrow/\downarrow to the entry you wish to store as direct access memory.
- 6 Press **OK** to confirm.
 - A validation tone is emitted.

6.7.6.2 Delete Direct Access Memory

- 1 Press **MENU** in idle mode, scroll \uparrow/\downarrow to **Phonebook** and press **SELECT**, scroll \uparrow/\downarrow to **Direct Memory** and press **SELECT**.
- 2 Scroll \uparrow/\downarrow to select a key (Keys **0** to **9**) and press **VIEW**.
 - The stored number is displayed (if any).
- 3 Press **SELECT** to display the menu options.
- 4 Scroll \uparrow/\downarrow to **Delete** and press **SELECT**.
- 5 Press **OK** to confirm.
 - A validation tone is emitted.

6.7.7 Copy phonebook from SIM card

This feature allows you to copy the SIM card phonebook of your mobile phone to the phonebook of your handset.

- 1 Open the SIM card tray and remove it from the base station.

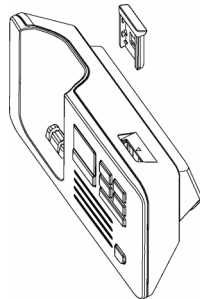

- 2 Slide the SIM card between the retaining clips, microchip facing down, until it stops.

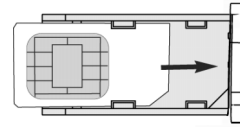

- 3 Put the SIM card tray back in the slot on the base station and push into place until it latches.
- 4 On the handset, press **MENU**, scroll \uparrow/\downarrow to **Phonebook** and press **SELECT**, scroll \uparrow/\downarrow to **Copy from SIM** and press **SELECT**.
- 5 Scroll \uparrow/\downarrow to **Copy All** or **Select Entry** and press **SELECT** to confirm.
 - If you choose **Copy All** then all entries in the SIM card will be copied to your phonebook.
 - If you choose **Select Entry**, you can browse the SIM card entries and select the ones you wish to copy (the entries in your SIM card may not be shown in alphabetical order).
- 6 Enter the PIN code of the SIM card (if required).
 - The copy progress will be displayed on the screen.
 - A message **Completed!** will be displayed upon successful completion

Note

Your handset has the capacity to read the phonebook contents for standard SIM cards, including 3G SIM cards. If the handset is unable to read the SIM card, or no SIM card is detected, the screen will display an error message **No SIM Card!** and return to previous menu.

If the name on the SIM card is exactly the same as an existing name on the phonebook of your handset, you will be prompted whether or not to overwrite the phonebook entry.

Tip

You can select **CANCEL** anytime to abort the process.

- 7 You can now retrieve your SIM card and replace the SIM card cover.

6.7.8 Transfer phonebook

This feature allows you to transfer the phonebook from one handset to another handset when there are at least 2 handsets registered to your base station.

- 1 Press **MENU** in idle mode, scroll \uparrow to **Phonebook** and press **SELECT**, scroll \uparrow to **Phbk transfer** and press **SELECT**.
- 2 Scroll \uparrow to **Copy All** or **Select Entry**.
 - If you choose **Copy All** then all entries in the handset will be copied to the selected handsets. If the target phonebook contains a name that is exactly the same as the existing phonebook, you will be prompted whether or not to overwrite the phonebook entry.
 - If you choose **Select Entry**, you can browse the phonebook entries and select the ones you wish to copy. For each selected entry, you will be prompted on the selected handsets whether or not to overwrite the phonebook entry in the target phonebook. **OVERWRITE?** will be displayed on the selected handsets, press **YES** to confirm or **NO** to cancel.
- 3 Press **SELECT** to confirm.
 - The handset numbers which are available for transfer will be displayed. If there are more than 2 handsets, scroll \uparrow to **All Handsets** or scroll \uparrow to select a specific handset.

Note

The receiving handsets must be in idle mode or screensaver mode before the phonebook entries can be successfully transferred.

- 1 Press **SELECT** to confirm.
 - The copy progress will be displayed on the screen.
 - A message **Completed!** will be displayed upon successful completion.

Tip

You can press **BACK** anytime to abort the process. You can only abort this process from the original handset which you are performing the phonebook transfer.

6.8 Using the Redial list

The redial list stores the last 20 numbers dialled. A maximum of 24 digits can be displayed for each entry.

6.8.1 Access Redial list

- 1 Press **REDIAL** in idle mode and scroll \uparrow to browse the redial list.
 - The last number dialled will appear first in the redial list. If the redial number matches a phonebook entry, the name will be displayed instead.
- 2 To view the details of a redial number, press **MENU** and press **SELECT** to select **View**.

Note

To return to idle mode, press **OFF** key.

6.8.2 Save a redial number into the phonebook

- 1 Press **REDIAL** in idle mode and scroll \uparrow to select an entry.
- 2 Press **MENU**, scroll \uparrow to **Save number** and press **SELECT**.
- 3 Enter the name of the contact (maximum 14 characters) and press **OK**.
- 4 Edit the number if necessary and press **OK**.
- 5 Scroll \uparrow to choose a group (<No Group>, <Group A>, <Group B>, <Group C>) and press **SELECT**.
 - A validation tone is emitted.

Note

Press **BACK** to delete the last digit or character entered.

6.8.3 Delete a redial number

- 1 Press **REDIAL** in idle mode and scroll \uparrow to select an entry.
- 2 Press **MENU**, scroll \uparrow to **Delete** and press **SELECT**.
- 3 Press **OK** to confirm.
 - A validation tone is emitted.

6.8.4 Delete the redial list

- 1 Press **REDIAL** in idle mode.
- 2 Press **MENU**, scroll to **Delete All** and press **SELECT**.
- 3 Press **OK** to confirm.
 - A validation tone is emitted.

6.9 Using the Call log

The call log offers quick access to the **Call List** and **Answ. Machine** sub-menus. If you have subscribed to Caller Line Identification service, the identity of the caller (caller's number or name) will be displayed together with the date and time of the call*. The **Call List** records the last 50 entries of the incoming calls. The calls (missed and received) are displayed in chronological order with the most recent call at the top of the list. When the call list is empty, the screen displays **List Empty**.

Note

* If the identity of the caller is withheld or the network does not provide the date and time information, then the information will not be displayed in the call log.

If you have not subscribed to Caller Line Identification service, there will not be any information displayed in the call log.

6.9.1 Access Call log

- 1 Press in idle mode, scroll to **Call List** or **Answ. Machine** and press **SELECT** to enter the respective sub-menus.

6.9.2 Save a call list entry into the phonebook

- 1 Press in idle mode, press **SELECT** to enter **Call List**, scroll to an entry in the call list and press **MENU**.
- 2 Press **SELECT** to select **Save number**.
- 3 Enter the name of the contact (maximum 14 characters) and press **OK**.

- 4 Edit the number (if necessary) and press **OK**.

- 5 Scroll to choose a group (**<No Group>**, **<Group A>**, **<Group B>**, **<Group C>**) and press **SELECT**.
 - A validation tone is emitted.

6.9.3 Delete a call list entry

- 1 Press in idle mode, press **SELECT** to enter **Call List**, scroll to an entry and press **MENU**.
- 2 Scroll to **Delete entry** and press **SELECT**.
- 3 Press **OK** to confirm deletion.
 - A validation tone is emitted.

6.9.4 Delete the call list

- 1 Press in idle mode, press **SELECT** to enter **Call List** and press **MENU**.
- 2 Scroll to **Delete All** and press **SELECT**.
- 3 Press **OK** to confirm deletion.
 - A validation tone is emitted.

6.10 Using the Intercom

Warning

Intercom and call transfer is only possible with handsets registered to the same base station.





This feature is only available when there are at least 2 registered handsets. It allows you to make free internal calls, transfer external calls from one handset to another and use the conference option.

6.10.1 Intercom another handset







Note

If the handset does not belong to SE740/745 range, this function may not be available.

- 1 Press key in idle mode.
 - Intercom is established immediately if there are only 2 registered handsets.

- 2 If there are more than 2 registered handsets, the handset numbers which are available for intercom will be displayed. Scroll  to **All Handsets** and press  **SELECT** to call all the handsets or scroll  to the specific handset you want to call and press  **SELECT**.

6.10.2 Transfer an external call to another handset

- 1 During the call, press and hold  key to put the external call on hold (the caller can no longer hear you).
- *Intercom is established immediately if there are only 2 registered handsets.*
- 2 If there are more than 2 registered handsets, the handset numbers which are available for intercom will be displayed. Scroll  to **All Handsets** and press  **SELECT** to call all the handsets or scroll  to the specific handset you want to call and press  **SELECT**.
- *The called handset rings.*
- 3 Press  key on the called handset to answer the internal call, where both internal callers can talk.
- *Intercom is established.*
- 4 Press  key on the first handset to transfer the external call to the called handset.
- *The external call is transferred.*

Note

If there is no answer from the called handset, press  key to resume the external call.

6.10.3 Answer an external call during intercom

- 1 When there is an incoming external call during an intercom, a new call tone is emitted.
- 2 To answer the external call and end the intercom, press .
- *Connection with the external call is established.*

Tip







To put the internal call on hold and answer the incoming external call, press  key.

6.10.4 Switch between an internal and external call

To switch between an internal or external call, press  key.

6.10.5 Establish a three-party conference call

The conference call feature allows one external call to be shared with two handsets (in intercom). The three parties can share the conversation and no network subscription is required.

- 1 During the call, long press  key to put the external call on hold (the caller can no longer hear you).
- *Intercom is established immediately if there are only 2 registered handsets.*
- 2 If there are more than 2 registered handsets, the handset numbers which are available for intercom will be displayed. Scroll  to **All Handsets** and press  **SELECT** to call all the handsets or scroll  to the specific handset you want to call and press  **SELECT**.
- *The called handset rings.*
- 3 Press  key on the called handset to answer the internal call, where both internal callers can talk.
- *Intercom is established.*
- 4 Press and hold  key for 2 seconds on the first handset to start the three-party conference.
- **CONFERENCE** will be displayed on the screen once the conference call is established.

Tip

If **CONFERENCE** mode is activated (see "Activate/Deactivate Conference mode" on page 34), a three-party conference call is automatically established if the second handset takes the line when there is already an external call in progress.

6.11 Paging

The paging feature enables you to locate a missing handset if the handset is in range and contains charged batteries.

- 1 Press key on the base station.
 - All the registered handsets start to ring.
- 2 Once retrieved, press any key on the handset to end the paging.

Note

If there are no key presses within 30 seconds, the handset and base station will automatically return to idle mode.

Tip

To stop paging, press key on the base station again.

6.12.2 Set Alarm

- 1 Press **MENU** in idle mode, scroll to **Clock & Alarm** and press **SELECT**, scroll to **Alarm** and press **SELECT**.
- 2 Scroll to **Off**, **On Once** or **On Daily** and press **SELECT**.
- 3 If you select **On Once** or **On Daily**, enter the time (HH:MM) for the alarm and press **OK**.

- A validation tone is emitted.

Note

The alarm tone and alarm icon will only sound/blink for 1 minute when the alarm time is reached. To mute the alarm tone, simply press any key on the handset.

6.12 Clock and Alarm settings

This feature allows you to set the date, time and alarm settings for your phone. The default date and time is 01/01/07 and 00:00 respectively.

6.12.1 Set Date and Time

- 1 Press **MENU** in idle mode, scroll to **Clock & Alarm** and press **SELECT**, press **SELECT** again to enter **Set Date/Time**.
- 2 Enter the current time (HH:MM) and current date (DD/MM/YY) and press **OK**.
 - A validation tone is emitted.

Note

Enter the date in Day/Month/Year format and the time in 24-hour format.

An error tone will be emitted if an invalid digit is entered in the date/time fields.

Hour: 00 to 23; Minute: 00 to 59

Month: 01 to 12; Date: 01 to 31 (except for February)

Warning

If your phone is connected to an ISDN line through an adaptor, the date & time may be updated after each call. The availability of date & time update is dependent on your network provider. Please check the date & time settings in your ISDN system or contact your network provider.

6.12.3 Set Alarm Tone

- 1 Press **MENU** in idle mode, scroll to **Clock & Alarm** and press **SELECT**, scroll to **Alarm Tone** and press **SELECT**.
- 2 Scroll to **Melody 1**, **Melody 2** or **Melody 3** to play the melody.
- 3 Press **SELECT** to set the alarm tone.
 - A validation tone is emitted.

6.12.4 Do not Disturb mode

This feature is available only if you have subscribed to Caller Line Identification (CLI) service from your network provider. When **Do not Disturb** mode is activated, the phone will ring only when there are calls received from authorised groups. For all other callers, the phone will display an incoming call message or the backlight will be turned on, but it will not ring. If the telephone answering machine is activated, it will answer the call to allow the caller to leave a message.

Note

By default, **Do not Disturb** mode is **Off**.

6.12.4.1 Activate/Deactivate Do not Disturb mode

- 1 Press **MENU** in idle mode, scroll to **Clock & Alarm** and press **SELECT**, scroll to **Do not Disturb** and press **SELECT**.
- 2 Press **SELECT** again to enter Activation.
- 3 Scroll to **On** or **Off**.
- 4 Press **SELECT** to confirm.

6.12.4.2 Set Day of Do not Disturb mode

- 1 Press **MENU** in idle mode, scroll to **Clock & Alarm** and press **SELECT**, scroll to **Do not Disturb** and press **SELECT**, scroll to **Set Day** and press **SELECT**.
- 2 Scroll to your desired option (**All Week**, **Weekday**, **Monday**, **Tuesday.....** or **Sunday**) and press **SELECT**.
- 3 If you select **All Week** or **Weekday**, press **SELECT** again to confirm.
- 4 If you select **Monday**, **Tuesday.....** or **Sunday**, a “√” will appear at the beginning of the row to indicate your selection. You can select more than 1 day.
- 5 After you have made your selection, scroll to **OK** and press **SELECT** to confirm and return to previous menu.

6.12.4.3 Set Time of Do not Disturb mode

- 1 Press **MENU** in idle mode, scroll to **Clock & Alarm** and press **SELECT**, scroll to **Do not Disturb** and press **SELECT**, scroll to **Set Time** and press **SELECT**.
- 2 Enter **Start Time** and **Stop Time**.
- 3 Press **SELECT** to confirm.

Note

By default, **Start Time** is **08:00** and **Stop Time** is **20:00**.

6.12.4.4 Set allowed caller

- 1 Press **MENU** in idle mode, scroll to **Clock & Alarm** and press **SELECT**, scroll to **Do not Disturb** and press **SELECT**, scroll to **Allowed caller** and press **SELECT**.
- 2 Scroll to your desired option (**Standard**, **Group A**, **Group B** or **Group C**).
- 3 Press **OK** to confirm.

Note

By default, no group is allowed when **Do not Disturb** mode is activated.

7 Personal settings







7.1 Handset Tones

7.1.1 Set the Ring Volume

Danger

When setting the ring volume of your phone or when the handset rings during an incoming call, please do not hold the handset too close to your ear as the volume of the ringing tone may damage your hearing.

There are 6 ringer volume options (**Silence**, **Low**, **Medium**, **High**, **Boost** and **Progressive**). The default level is **Medium**.









- 1 Press  **MENU** in idle mode, scroll  to **Personal Set** and press  **SELECT** press  **SELECT** to enter **Handset Tones** and press  **SELECT** again to enter **Ring Volume**.
- 2 Scroll  to your desired volume level and press  **SELECT** to confirm.
 - A validation tone is emitted and the screen returns to previous menu.

Note

When **Silence** is activated, the icon  will be displayed on the screen.

7.1.2 Set the Ring Melody

There are 10 polyphonic ring melodies available on your handset.











- 1 Press  **MENU** in idle mode, scroll  to **Personal Set** and press  **SELECT**, press  **SELECT** to enter **Handset Tones**, scroll  to **Ring Melody** and press  **SELECT**.
- 2 Scroll  to your desired melody to play the melody.
- 3 Press  **SELECT** to set the ring melody.
 - A validation tone is emitted and the screen returns to previous menu.

7.1.3 Set the Group Melody

To benefit from this feature, you must subscribe to the Caller Line Identification service. Refer to “Caller Line Identification” on page 20.









This feature enables you to select and set the melodies to be played when there is an external incoming call from a contact whose name is stored in your phonebook and belongs to a phonebook group. You can associate 1 ring melody to each group.

There are three phonebook groups (Group A, B and C) available for you to organise your contacts. Each group can be assigned a unique melody.

- 1 Press  **MENU** in idle mode, scroll  to **Personal Set** and press  **SELECT**, press  **SELECT** to enter **Handset Tones**, scroll  to **Group Melody** and press  **SELECT**.
- 2 Scroll  to the group for which you wish to set melody and press  **SELECT**.
- 3 Scroll  to the desired melody to play the melody.
- 4 Press  **SELECT** to set the group melody.
 - A validation tone is emitted and the screen returns to previous menu.







7.1.4 Activate/Deactivate Key Beep

A single beep is emitted when a key is pressed. You can enable or disable the key beep. By default, the key beep is **On**.

- 1 Press  **MENU** in idle mode, scroll  to **Personal Set** and press  **SELECT**, press  **SELECT** to enter **Handset Tones**, scroll  to **Key Beep** and press  **SELECT**.
- 2 Scroll  to **On** or **Off** and press  **SELECT** to confirm.
 - A validation tone is emitted and the screen returns to previous menu.







7.2 Set Wallpaper

This feature allows you to select the wallpaper to be displayed in idle mode. There are 5 wallpapers pre-installed on your handset. The 5th wallpaper is a blank wallpaper.

- 1 Press  **MENU** in idle mode, scroll  to **Personal Set** and press  **SELECT**, scroll  to **Wallpaper** and press  **SELECT**.
- 2 Scroll  to your desired wallpaper and press  **SELECT** to confirm.
 - A validation tone is emitted and the screen returns to previous menu.







7.3 Set Contrast Level

There are 3 contrast level options (**Level 1**, **Level 2** or **Level 3**). The default contrast level is **Level 2**.

- 1 Press  **MENU** in idle mode, scroll  to **Personal Set** and press  **SELECT**, scroll  to **Contrast** and press  **SELECT**.
- 2 Scroll  to your desired contrast level (**Level 1**, **Level 2** or **Level 3**) and press  **SELECT** to confirm.
 - A validation tone is emitted and the screen returns to previous menu.







7.4 Change the Handset Name

You can name the handset and display the handset name in idle mode. The default handset name of your handset is **PHILIPS**.

- 1 Press  **MENU** in idle mode, scroll  to **Personal Set** and press  **SELECT**, scroll  to **Handset Name** and press  **SELECT**.
- 2 Edit the handset name (maximum 14 characters) and press  **OK** to confirm.
 - A validation tone is emitted and the screen returns to previous menu.

7.5 Activate /Deactivate Auto Pick-up







This function enables you to answer a call automatically by simply lifting the handset off the base station. By default, the Auto Pick-up feature is **Off** and in this case you have to press the  key to answer a call.

- 1 Press  **MENU** in idle mode, scroll  to **Personal Set** and press  **SELECT**, scroll  to **Auto Pick-up** and press  **SELECT**.
- 2 Scroll  to **On** or **Off** and press  **SELECT** to confirm.

- A validation tone is emitted and the screen returns to previous menu.







7.6 Activate /Deactivate Auto Hang-up

This function enables you to end a call automatically by simply replacing the handset on the base station. By default, the Auto Hang-up feature is **On**.

- 1 Press  **MENU** in idle mode, scroll  to **Personal Set** and press  **SELECT**, scroll  to **Auto Hang-up** and press  **SELECT**.
- 2 Scroll  to **On** or **Off** and press  **SELECT** to confirm.
 - A validation tone is emitted and the screen returns to previous menu.

7.7 Change the Display Language

Your handset can support different display languages, depending on your country selection during the **WELCOME** mode.

- 1 Press  **MENU** in idle mode, scroll  to **Personal Set** and press  **SELECT**, scroll  to **Language** and press  **SELECT**.
- 2 Scroll  to your desired language and press  **SELECT** to confirm.
 - A validation tone is emitted and the screen returns to previous menu.

* Tip

Once the display language is set, the option menus on the handset will switch to display in the selected language immediately. However, it will not change the language of the predefined outgoing message of your answering machine.

7.8 Babysit mode

You must have at least 2 handsets registered to your base station to be able to use this feature (see page 32 "Registration"). This feature allows you to monitor, e.g. the baby's room.

To use the Babysit feature you need to activate it (e.g. on handset 1) and enter the number of the handset to be called (e.g. handset 2) in the event that there are noises in the monitored room. Place the handset which is in Babysit mode (e.g.

handset 1) in the room to be monitored. If this handset detects a sound level greater than a certain threshold, it will automatically initiate an internal call to the selected handset (e.g. handset 2).

7.8.1 Activate Babysit Mode

Note

In Babysit mode, all keys are deactivated except for **MENU** key. The handset cannot perform any normal operation (making an outgoing call, receiving an incoming call, intercom another handset, paging, etc.) once this function is activated.

- 1 Press **MENU** in idle mode, scroll to **Personal Set** and press **SELECT**, scroll to **Babysit mode** and press **SELECT**.
 - *Babysit mode is displayed on the screen.*
- 2 Scroll through the list of handsets available and press **SELECT** to select the handset to be called.

7.8.2 Deactivate Babysit Mode

- 1 Press **MENU** in idle mode, select **Off** and press **SELECT**.

7.9 Set Backlight time

- 1 Press **MENU** in idle mode, scroll to **Personal Set** and press **SELECT**, scroll to **Backlight Time** and press **SELECT**.
- 2 Scroll to **20s**, **40s** or **60s** and press **SELECT** to confirm.
 - *A validation tone is emitted.*

Note

By default, the backlight remains on for 20 seconds after each activation such as an incoming call, key presses, lifting the handset off the base station, etc. The colour of the LCD backlight is Amber.

7.10 Set Theme Colour

- 1 Press **MENU** in idle mode, scroll to **Personal Set** and press **SELECT**, scroll to **Theme Colour** and press **SELECT**.
- 2 Scroll to **Theme Colour 1**, **Theme Colour 2** or **Theme Colour 3** and press **SELECT** to confirm.
 - *A validation tone is emitted.*







8 Advanced settings







8.1 Change Recall time

Recall time (or dial delay) is the time delay by which the line will be disconnected after you press  key. It can be set to short, medium or long.

The default value of recall time that is preset in your handset should be the best suited for your country network and therefore you should not need to change it.

Note







This setting is useful when using network services. The use of some services accessed with [ + ], [ + ], [ + ] (call waiting, call forward...) will depend on your recall time setting. Please contact your network provider for more details on this feature.

- 1 Press  **MENU** in idle mode, scroll  to **Advanced Set** and press  **SELECT**, press  **SELECT** to enter **Recall Time**.
- 2 Scroll  to **Short, Medium or Long** and press  **SELECT** to confirm.
 - A validation tone is emitted and the screen returns to previous menu.

8.2 Call Barring



Call barring enables you to restrict selected handsets from dialling a phone number beginning with certain digits. You can set up to 4 different barring numbers, with each number containing up to 4 digits.

8.2.1 To activate/deactivate Call Barring

- 1 Press  **MENU** in idle mode, scroll  to **Advanced Set** and press  **SELECT**, scroll  to **Call Barring** and press  **SELECT**.
- 2 Enter the Master PIN when prompted and press  **OK** to confirm.

Note

By default, the Master PIN is 0000.

- 3 Press  **SELECT** to enter **Barring Mode**.
- 4 Scroll  to **On** or **Off** and press







 **SELECT** to confirm.

- A validation tone is emitted and the screen returns to previous menu.

8.2.2 To modify Call Barring number





Note

If a restricted number is dialled, the call will not be connected. When this happens, the phone emits an error tone and returns to idle mode.

- 1 Press  **MENU** in idle mode, scroll  to **Advanced Set** and press  **SELECT**, scroll  to **Call Barring** and press  **SELECT**.
- 2 Enter the Master PIN when prompted and press  **OK** to confirm.

Note

By default, the Master PIN is 0000.







- 3 Scroll  to **Barring Nr.** and press  **SELECT**.
- 4 Scroll  to **Number 1, Number 2, Number 3** or **Number 4** and press  **SELECT**.
- 5 Enter the barring number (maximum 4 digits) and press  **OK** to confirm.
 - A validation tone is emitted and the screen returns to previous menu.

8.3 Baby Call

When activated, the Baby Call feature enables you to dial a number by pressing any key on your handset. This feature is very useful for direct access to emergency services.



You can enter up to 24 digits for baby call number.

8.3.1 To activate Baby Call mode

- 1 Press  **MENU** in idle mode, scroll  to **Advanced Set** and press  **SELECT**, scroll  to **Baby call** and press  **SELECT**.
- 2 Enter the Master PIN when prompted and press  **OK** to confirm.



Note

By default, the Master PIN is 0000.







- 3 Press  **SELECT** to enter **Mode**.
- 4 Scroll  to **On** and press  **SELECT** to confirm.

- 3 Enter the Baby Call number and press  **OK** to confirm.
 - A validation tone is emitted.

8.3.2 To deactivate Baby Call mode



- 1 Long press  **MENU** (when Baby Call mode has been activated before).
- 2 Scroll  to **Off** and press  **SELECT** to confirm.

8.3.3 To change Baby Call number

- 1 Press  **MENU** in idle mode, scroll  to **Advanced Set** and press  **SELECT**, scroll  to **Baby call** and press  **SELECT**.
- 2 Enter the Master PIN when prompted and press  **OK** to confirm.

Note

By default, the Master PIN is 0000.





- 3 Scroll  to **Number** and press  **SELECT**.
 - The last stored Baby Call number is displayed (if any).
- 4 Enter the baby call number (maximum 24 digits) and press  **OK** to confirm.
 - A validation tone is emitted and the screen returns to previous menu.

8.4 Registration

The procedures described below are the procedures that you will find in your handset. The procedures may vary according to the handset you want to register. In this case, please refer to the manufacturer of the additional handset. Additional handsets must be registered to the base unit before you can use them. Up to 6 handsets can be registered to one base station. The Master PIN is required before you can register or unregister handsets.

Note



By default, the Master PIN is 0000.

- 1 On the base station, press and hold  for approximately 3 seconds.
 - A validation tone is emitted.
- 2 On the handset, press  **MENU**, scroll  to **Advanced Set** and press  **SELECT**,

scroll  to **Registration** and press  **SELECT**.







Note

If no action is taken on the handset within 10 seconds, the registration procedure will be aborted. If this happens, please repeat Step 1.







- 3 Scroll  to select the base station to be registered to and press  **OK** to confirm.
- 4 Enter the Master PIN when prompted and press  **OK** to start registration.
 - If the PIN is incorrect, **Incorrect PIN** will be displayed and the handset returns to idle mode.
- 5 Upon successful registration, a validation tone is emitted and the screen returns to idle mode.

8.5 Select best Base Station

One handset can be registered to up to 4 different base stations. By default, the handset will register to BASE 1. If you select **Best Base**, the handset will register to the nearest base station.



- 1 Press  **MENU** in idle mode, scroll  to **Advanced Set** and press  **SELECT**, scroll  to **Select Base** and press  **SELECT**.
- 2 Scroll  to the desired base station and press  **OK** to confirm.
 - The handset will start to search for the base station. If the selected base is found, a validation tone is emitted.

8.6 Unregister a handset

- 1 Press  **MENU** in idle mode, scroll  to **Advanced Set** and press  **SELECT**, scroll  to **Unregistration** and press  **SELECT**.
- 2 Enter the Master PIN when prompted and press  **OK** to confirm.

Note

By default, the Master PIN is 0000.

- 3 Scroll  to select the handset number to unregister and press  **SELECT**.
 - A validation tone is emitted to indicate successful unregistration and the screen shows **UNREGISTERED**.

Note

If no action is taken on the handset within 15 seconds, the unregistration procedure will be aborted and the handset returns to idle mode. To unregister a handset that does not belong to the SE740/745 range, you can only use the SE740/745 handset to unregister it.

8.7 Change Master PIN

The Master PIN is used for setting call barring/baby call number, registration/unregistration of handsets and for accessing the answering machine remotely. The default Master PIN number is 0000. The maximum length of the Master PIN is 4 digits. This PIN is also used to protect the settings of your handset. Your handset will prompt you whenever the PIN is required.

Note

The default pin code is preset to 0000. If you change this PIN code, keep the PIN details in a safe place where you have easy access to them. Do not lose the PIN code.

- 1 Press **MENU** in idle mode, scroll **Advanced Set** and press **SELECT**, scroll **Change PIN** and press **SELECT**.
- 2 Enter the current Master PIN when prompted and press **OK** to confirm.
 - The PIN entered will be shown as asterisks (*) on the screen.
- 3 Enter the new PIN and press **OK**.
- 4 Enter the new PIN again and press **OK** to confirm PIN change.
 - A validation tone is emitted, the message **New PIN Stored** appears and the screen returns to previous menu.

Tip

If you forget your PIN, you will need to reset your phone to its default settings. See next section "Reset Unit" for more details.

8.8 Reset Unit

You can reset your phone to its default settings with this feature.

Warning

Upon reset, all your personal settings, call log and redial list entries will be deleted and the phone

Advanced settings

will return to its default settings. However, your phonebook as well as the unread messages of your answering machine will remain unchanged after reset.

Note

You may have to configure your phone once again. In this case the WELCOME mode will appear again after master reset. (go to chapter 3.3)

- 1 Press **MENU** in idle mode, scroll **Advanced Set** and press **SELECT**, scroll **Reset** and press **SELECT**.
- 2 Scroll **Yes** and press **SELECT**.
A validation tone is emitted.
 - The unit is reset to its default settings (see "Default settings" on page 35).

8.9 Set Auto Prefix

This feature allows you to define a prefix number to be added to the beginning of a number during predialling (see "Predialling" on page 17). You can also use this feature to add a detect string to match and replace the first few digits of the number during predialling.

You can enter up to a maximum of 5 digits for the detect string and 10 digits for the auto prefix number.

Note

The use of your SE745 cannot be guaranteed with all types of PABX.

- 1 Press **MENU** in idle mode, scroll **Advanced Set** and press **SELECT**, scroll **Auto Prefix** and press **SELECT**.
- 2 **Detect digit** is displayed on the screen. Press **SELECT** to enter.
 - The last stored detect string is displayed (if any).
- 3 Enter a detect string number (maximum 5 digits) and press **OK** to confirm.
 - **Prefix number** is displayed on the screen.
- 4 Press **SELECT** to enter.
 - The last stored prefix number is displayed (if any).
- 5 Enter the prefix number (maximum 10 digits) and press **OK** to confirm.
 - A validation tone is emitted and the screen returns to previous menu.

Note

If no detect string (blank) is entered, the prefix number will be automatically added to the predial number after  key is pressed.

For numbers starting with *, # or a pause (P), the prefix number will not be added to the predial number after  key is pressed.









8.10 Country Selection

The availability of this menu is dependent on your country.

You can select another country different from the one chosen during WELCOME mode.







Note

Once the country is selected, the default line settings for the selected country will be applied to the phone automatically (e.g. Recall time, Dial mode, Language, etc).

- 1 Press  **MENU** in idle mode, scroll  to **Advanced Set** and press  **SELECT**, scroll  to **Country** and press  **SELECT**.
- 2 Scroll  to the country of your choice and press  **SELECT**.
- 3 Press  **SELECT** again to confirm.
 - A validation tone is emitted and the screen returns to previous menu.







8.11 Activate/Deactivate Conference mode

When conference mode is activated, you can initiate a three-party conference call with a second handset registered to your base station automatically if the second handset takes the line when there is already an external call in progress. The default setting for this mode is **Off**.

- 1 Press  **MENU** in idle mode, scroll  to **Advanced Set** and press  **SELECT**, scroll  to **Conference** and press  **SELECT**.
- 2 Scroll  **SELECT** to **On** or **Off** and press  **SELECT** to confirm.
 - A validation tone is emitted and the screen returns to previous menu.

8.12 Activate/Deactivate XHD Sound mode

The **XHD Sound** mode is an exclusive feature making your phone conversations sounding just like real-life conversations. When activated, the **XHD Sound** mode transmits with high fidelity all the emotions of the call as if your correspondent was talking next to you.

- 1 Press  **MENU** in idle mode, scroll  to **Advanced Set** and press  **SELECT**, scroll  to **XHD Sound** and press  **SELECT**.
- 2 Scroll  to **On** or **Off** and press  **SELECT** to confirm.

* Tip







During a call, you can also press  **OPTION** and select **XHD Sound On/XHD Sound Off** to activate/deactivate **XHD Sound** mode.

When **XHD Sound** mode is activated during a call, **XHD Sound On** will appear on the screen for 2 seconds and the **XHD Sound** icon (see "Display icons" on page 10) will also appear to indicate that the call is now in **XHD Sound** mode.

If **XHD Sound** mode is deactivated during a call, **XHD Sound Off** will appear on the screen for 2 seconds and the normal call connected icon (see "Display icons" on page 10) will appear to replace the **XHD Sound** icon to indicate that the call is no longer in **XHD Sound** mode.

8.13 To set 1st Ring

When this function is set to **Off**, the first ring from a voice call will not sound. This is particularly useful in countries where calling line identity is sent after the first ring. Consequently, the phones in the house will not ring when a message arrives.

- 1 Press  **MENU** in idle mode, scroll  to **Advanced Set** and press  **SELECT**, scroll  to **Set 1st Ring** and press  **SELECT**.
- 2 Scroll  to **On** or **Off** and press  **SELECT** to confirm.

**8.14 Default settings**

Ringer Volume	Medium
Earpiece Volume	Volume 3
Speaker Volume	Volume 3
Key Beep	On
Contrast	Level 2
Auto Pick-up	Off
Auto Hang-up	On
Babysit mode	Off
Alarm clock	Off
Barring mode	Off
Handset Name	PHILIPS
Date/Time	01/01/07; 00:00
Master PIN	0000
Barring mode	Off
XHD Sound mode	On
Night mode	Off

Answering Machine

Answer Mode	Answ. & Record
Number of rings before answer	5
Outgoing Messages	Predefined for Answ. & Record mode
Base station screening	On with default speakerphone level
Handset screening	Off
Base speaker	Level 5
Remote access	Deactivated

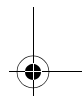
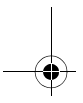
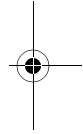
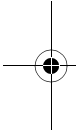

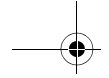

9 Games

9.1 Play Snake game

The objective of this game is to move the snake and eat as many "food blocks" as possible. When the food is eaten, the snake grows in length and the score increases. Once you hit the body of the snake itself, the game is over. .

- 1 Press **MENU** in idle mode, scroll to **Games** and press **SELECT**, scroll to **Snake** and press **SELECT**.

- *An instruction screen is displayed.*

Note

Press / / / keys to move up / move left / move right / move down respectively.

Press to pause/continue with the game.

Press to select the difficulty level.

- 2 To start the game, press **SELECT** or key.
- 3 To exit from the game, press .

9.2 Play Tetris game

You can rotate each shaped block as they fall such that they fit neatly into horizontal blocks. The more blocks you can gather within the same level, the more you will score.

- 1 Press **MENU** in idle mode, scroll to **Games** and press **SELECT**, scroll to **Tetris** and press **SELECT**.

- *An instruction screen is displayed.*

Note

Press / / / keys to rotate / move left / move right / move down respectively.

- 2 To start the game, press **SELECT**.

- 3 To exit from the game, press .

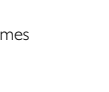
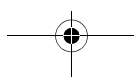

10 Telephone answering machine (TAM)

Your phone features an answering machine that records unanswered calls when it is activated. The answering machine can store up to 99 messages. The maximum recording time is 30 minutes (including all your personalised outgoing messages).

You can use the control keys on the base station to perform the basic functions of the answering machine such as message playback, deleting messages and adjustment of volume on the base station. For a description of each function of the control keys on the base station, please see "Overview of the base station" on page 11 for more details.





You can also use the answer machine menu on the handset to access the answering machine functions. There is also a menu to set the answering machine options.

To begin, press  key on your base station to switch on the answering machine (if it is switched off). Alternatively, you may switch on the answering machine via your handset (see "Switch the Answering Machine On/Off via handset" on page 39).















10.1 Play

10.1.1 Playback of new messages via handset





The last recorded message is played first via the loudspeaker. When all new messages have been played, the answering machine will stop and the  icon stops blinking.

■ Press  **MENU** in idle mode, scroll  to **Answer Machine** and press  **SELECT**, press  **SELECT** to enter **Play** menu.

■ During playback, you can:

Adjust volume	Press  key.
Stop playback	Press  to return to Play menu.
Repeat	Press  MENU , scroll  to Repeat and press  SELECT .
Next message	Press  MENU , scroll  to Next Message and press  SELECT .
Previous message	Press  MENU , scroll  to Prev. Message and press  SELECT .
Delete message	Press  MENU , scroll  to Delete and press  SELECT .
Switch the playback to earpiece	Press  key.

Tip

You can also playback messages by pressing  key in idle mode, scroll  to **Answer Machine** and press  **SELECT**, press  **SELECT** again to enter **Play** menu.

10.1.2 Playback of old messages via handset

Old messages can only be played if there are no new messages. The first recorded message will be played first and the next message will be played automatically until there are no more messages.

- 1 Press **MENU** in idle mode, scroll to **Answer Machine** and press **SELECT**, press **SELECT** to enter **Play** menu.
- 2 Press **SELECT**.
 - *The first recorded message will start to play until the last recorded message.*
- 3 During message playback, you can press **MENU** to select the available options (see options available under “Playback of new messages via handset” on page 37).

10.2 Delete all messages

Note

Unread messages will not be deleted.

Warning

Messages deleted cannot be recovered.

- 1 Press **MENU** in idle mode, scroll to **Answer Machine** and press **SELECT**, scroll to **Delete All** and press **SELECT**.
- 2 Press **OK** to confirm deletion of all your messages.
 - *A validation tone is emitted and the screen returns to previous menu.*

10.3 Memo recording

You can record a reminder message for yourself or for anyone else who uses your answering machine. The answering machine treats a memo recording the same way it treats any incoming message, and the new message indicator will flash accordingly. To play the memo recording, please refer to “Play” on page 37

- 1 Press **MENU** in idle mode, scroll to **Answer Machine** and press **SELECT**, scroll to **Record Memo** and press **SELECT**.

- 2 Press **START** to start recording the memo.
- 3 Press **STOP** to end the recording.
 - *The recorded memo is automatically saved.*
- 4 Press **BACK** at any time to return to the previous menu.

10.4 Set the Answer mode

There are 2 answer modes available: Answer Only, and Answ. & Record.

By default, the answer mode is **Answ. & Record**, by which your correspondent can leave a message on the answering machine.

This can be changed to **Answer Only** mode, by which your correspond cannot leave any messages on the answering machine.

- 1 Press **MENU** in idle mode, scroll to **Answer Machine** and press **SELECT**, scroll to **Answ. Mode** and press **SELECT**.
- 2 Scroll to **Answ. & Record** or **Answer Only** and press **SELECT**.
 - *The answer mode is set.*
- 3 Scroll to **Personalised** or **Predefined** and press **SELECT**.
 - *If you set your outgoing message as Personalised, you can now proceed to record your personalised outgoing message (see “Record your Personalised Outgoing Message” in the next section).*





Note

Depending on the answer mode you have selected, the appropriate default outgoing message is played once the answering machine picks up an incoming call. The language of the default outgoing message depends on the country selected in Welcome mode (see page 13).

10.5 Record your Personalised Outgoing Message

You can record one personal outgoing message. This personal outgoing message replaces the default ones. To revert to the default outgoing message, simply delete the personal outgoing message you have recorded. If you are not



satisfied with the recorded outgoing message, simply record a new message to overwrite the old one.

- 1 Repeat Steps 1 to 4 in “Set the Answer mode” in the previous section.
- 2 Scroll  to **Record message** and press  **SELECT**.
- 3 Press  **START** to start recording and press  **STOP** to end the recording.
 - The recorded message will be played and the screen returns to previous menu once it has finished playing.
 - When you record a new outgoing message, the previous one (if any) is overwritten automatically.







 **Note**

The maximum length of an outgoing message is 2 minutes.

10.5.1 Playback your Personalised Outgoing Message

- 1 Repeat Steps 1 to 4 in “Set the Answer mode” on page 38.
- 2 Scroll  to **Play message** and press  **SELECT**.
 - The previously recorded outgoing message (if any) is played, and then the screen returns to previous menu.









10.6 Switch the Answering Machine On/Off via handset

- 1 Press  **MENU** in idle mode, scroll  to **Answer Machine** and press  **SELECT**, scroll  to **Ans. On/Off** and press  **SELECT**.
- 2 Scroll  to **On** or **Off** and press  **SELECT** to confirm.
 - A validation tone is emitted and the screen returns to previous menu.

10.7 Answering Machine settings

10.7.1 Ring Delay

This is the number of rings before the answering machine answers and starts playing your greeting message. You can set the answering machine to start playing your greeting message after **1 to 7** rings or **Toll saver**. The default ring delay is **5**.

- 1 Press  **MENU** in idle mode, scroll  to **Answer Machine** and press  **SELECT**, scroll  to **Ans. Settings** and press  **SELECT**, press  **SELECT** to enter **Ring delay**.
- 2 Scroll  to your desired ring delay setting (**1 to 7** rings or **Toll saver**) and press  **SELECT** to confirm.
 - A validation tone is emitted and the screen returns to previous menu.

 **Tip**

Toll saver mode can save you the cost of a long-distance call when you check your messages remotely. If there are new messages in your answering machine, the outgoing message will start playing after 3 rings. If there are no new messages, the outgoing message will be played after 5 rings. Hence, if you want to check if you have any messages without incurring call charges, you can hang up the call after the 4th ring.

10.7.2 Remote Control Access

If you are far away from home and want to check the messages on your answering machine, you can make use of the remote access feature to check your messages using another phone. Once you dial your home number from any other phone and enter the remote access code*, you will be able to obtain the messages on your answering machine. The keypad on the phone you use to dial acts like the functions on your answering machine where you can play or delete messages, turn your answering machine on or off, etc.

 **Note**

This feature is deactivated by default.

* Remote access code (which is the same as your Master PIN code) prevents any unauthorised

remote access of your answering machine. Before you can use the remote access feature, you must change your Master PIN code. Your Master PIN code cannot be the default 0000. To change your Master PIN code, refer to “Change Master PIN” on page 33.

10.7.2.1 Activate/Deactivate Remote Access

- 1 Press **MENU** in idle mode, scroll to **Answer Machine** and press **SELECT**, scroll to **Ans. Settings** and press **SELECT**, scroll to **Remote access** and press **SELECT**.
- 2 Scroll to **Activated** or **Deactivated** and press **SELECT** to confirm.
 - A validation tone is emitted and the screen returns to previous menu.

10.7.2.2 Controlling the Answering Machine from an external call

- 1 From another phone, dial home.
 - The answering machine answers and starts playing your greeting message.
- 2 Within 8 seconds, press # key on the phone you use to dial and enter the remote access code (same as your Master PIN code).
 - If the remote access code is incorrect, an error tone is emitted. Enter the access code again until you get the correct number.
 - If you did not enter the remote access code within 10 seconds, the answering machine will drop the line immediately.
 - If the remote access code (same as your Master PIN code) is correct, you will hear a validation tone.
 - New messages (if any), will be played automatically and stop when there are no more new messages.

Note

If there are no new messages, the answering machine will not play any messages. The following table indicates how to access the below features during remote access procedure:

Press	To
1	Replay the current message or go to previous message
2	Play old messages or stop them
3	Go to next message
4	Delete current message
0	Turn the answering machine on/off

10.8 Call Screening

10.8.1 Set Handset Call Screening

If handset call screening is set to **On**, you can hear incoming messages via the handset speaker and decide whether or not to take the call. To take the call, press . This feature is deactivated by default.

Note

If you have multiple handsets, only 1 handset can enable handset call screening for each call.

- 1 Press **MENU** in idle mode, scroll to **Answer Machine** and press **SELECT**, scroll to **Ans. Settings** and press **SELECT**, scroll to **HS Screening** and press **SELECT**.
- 2 Scroll to **On** or **Off** and press **SELECT**.
 - A validation tone is emitted and the screen returns to previous menu.

10.8.2 Set Base Call Screening

If base call screening is set to **On**, you can hear incoming messages via the loudspeaker of the base station and decide whether or not to pick up the call. To take the call, press . This feature is activated by default.

- 1 Press **MENU** in idle mode, scroll to **Answer Machine** and press **SELECT**, scroll to **Ans. Settings** and press **SELECT**, scroll to **Base Screening** and press **SELECT**.
- 2 Scroll to **On** or **Off** and press **SELECT**.

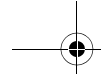

- A validation tone is emitted and the screen returns to previous menu.

10.8.3 Set Voice Language

This menu allows you to change the language of the predefined outgoing message. The availability of this menu and the language options available are country dependent.

- 1 Press **MENU** in idle mode, scroll to **Answer Machine** and press **SELECT**, scroll to **Ans. Settings** and press **SELECT**, scroll to **Voice Language** and press **SELECT**.
 - The current selected language is highlighted.
- 2 Scroll to your preferred language and press **SELECT** to confirm.
 - A validation tone is emitted and the screen returns to previous menu.

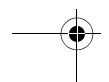
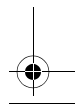
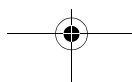
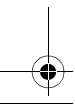
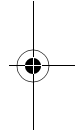
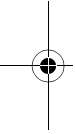



11 Technical data

Display

- Progressive LCD backlight

General telephone features

- Dual mode caller name & number identification
- 10 polyphonic ringer melodies

Phonebook list, Redial list and Call log

- Phonebook list with 250 entries
- Redial list with 20 entries
- Call log with 50 entries

Battery

- 2 x HR AAA NiMh 600 mAh batteries

Power Consumption

- Power consumption at idle mode: around 800mW

Weight and dimensions

- xxx grams
- xxx mm x xxx mm x xx mm
(H x D x W)

Temperature range

- Operation: Between 0 and 35° C (32 to 95° F).
- Storage: Between -20 and 45° C (-4 to 113° F).

Relative humidity

- Operation: Up to 95% at 40°C
- Storage: Up to 95% at 40°C

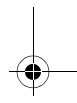
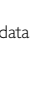
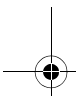
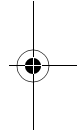
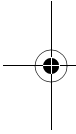

12 Frequently asked questions

In this chapter, you will find the most frequently asked questions and answers about your phone.

Connection

The handset does not switch on!

- Charge the batteries: Put the handset on the base station to charge. After a few moments, the phone will switch on.

The handset does not charge!

- Check charger connections.

icon is not blinking during charge!

- Battery is full: There is no need to charge the battery.
- Bad battery contact: Adjust the handset slightly.
- Dirty contact: Clean the batteries contact with a dry cloth.
- Wrong batteries installed: Use only AAA rechargeable batteries supplied with your unit. There could be risk of battery leakage if you use alkaline batteries or other battery types.

Communication is lost during a call!

- Charge the battery
- Move closer to the base station.

The phone is "Out of range"!

- Move closer to the base station.

WARNING BATT. is displayed on handset!

- Use only AAA rechargeable batteries supplied with your unit. There could be risk of battery leakage if you use alkaline batteries or other battery types.

Set-up

SEARCHING... is displayed on handset and icon is blinking!

- Move closer to the base station.
- Make sure that your base station is on.
- Reset your unit and restart handset registration (see "Registration" on page 32).

Sound

Handset does not ring!

Check that the **Ring Volume** is not set to **Silence**, and make sure  icon is not displayed on the screen (see "Set the Ring Volume" on page 28).

Caller cannot hear me at all!

Microphone may be muted: During a call, press  **UNMUTE**.

There's no dialling tone!

- No power: Check the connections.
- Batteries are empty: Charge the batteries.
- Move closer to the base station.
- Wrong line cable used: Use the line cable provided.
- Line adaptor is required: Connect the line adaptor to the line cord.

Caller cannot hear me clearly!

- Move closer to the base station.
- Move the base station at least one metre away from any electronic appliances.

Frequent noise interference on my radio or television!

- Move the base station as far away as possible from the electrical appliances.

Product behaviour

Keypad does not work!

- Unlock your keypad: Long press  in idle mode.

The handset warms up when making a long call!

- This is a normal behavior. The handset consumes energy while calling.

The handset cannot be registered to the base station!

- Maximum number of handsets (6) has been reached. To register a new handset, unregister an existing handset.
- Remove and replace the handset batteries.
- Try again by disconnecting and connecting the base station power supply and follow the procedure to register a handset.
- Make sure that you have entered the correct PIN code. If you have not changed it, by default it is 0000.

Caller's number is not displayed!

- Service is not activated: Check your subscription with your network operator.

Poor audio quality and the antenna icon is blinking!

- The indoor and outdoor range of the phone is up to 50 metres and 300 metres respectively. When the handset moves beyond the operation range, the antenna icon  will blink.

My handset keeps going into idle mode!

- If there are no key presses for 30 seconds, the handset will automatically return to idle mode. It will also return to idle mode automatically when you place the handset back on the base station.

Phonebook entry cannot be stored and MEMORY FULL is displayed!

- Delete an entry to free memory before saving your contact again.

The copy from my mobile phone SIM card to SE745 is not complete!

- Only phonebook entries from your mobile phone SIM card will be transferred. If you have phonebook entries on your mobile phone memory, transfer them to your mobile phone SIM card before transferring to your SE745.

The Master PIN code is wrong!

- The default master PIN is 0000.
- If it has been changed before, and you cannot remember the new one, reset the handset to revert to the default master PIN code (see "Reset Unit" on page 33).

The answering machine does not record messages!

- Memory is full: Delete your old messages.
- The **ANSWER ONLY** mode has been activated. Deactivate **ANSWER ONLY** and activate **ANSWER & REC** mode (see "Set the Answer mode" on page 38).

Remote control access does not work!

- Activate Remote Control Access (see "Remote Control Access" on page 39).

The phone hangs up during remote access!

- You have not changed change your Master PIN code. The remote access code cannot be 0000. Change your Master PIN code (see "Change Master PIN" on page 33).
- You have taken more than 8 seconds to enter the Master PIN code. Enter the code again within 8 seconds.

Answering machine stops before the recording is finished!

- Memory is full: Delete your old messages.

13 Index

A

Accessories 7
Alarm 26
Alarm Tone 26
Answer a call 17
Answer an external call 25
Answering Machine mode 38
Auto Answer 29

B

Baby Call 31
Backlight time 30

C

Call Barring 31
Call in progress 19
Call log 17, 24
Call Screening 40
Charge battery 13
Clock and Alarm 26
Conference call 25
Connect base station 12
Country Selection 34

D

Date and Time 26
Default settings 35
Delete a call list entry 24
Delete a redial number 23
Delete call list 24
Delete phonebook 21
Delete redial list 24
Direct dialling 17
Display icons 10

E

End a call 18

H

Handset Name 29
Handset Tones 28
Handsfree answering 17

I

Install battery 13
Install phone 13
Intercom 24

K

Key Tone 28
Keypad lock/unlock 19

L

Language 29
LED indicator 11
Loudspeaker mode 19
Loudspeaker volume 20

M

Make a call 17
Master PIN 33
Memo recording 38
Menu structure 14
Mute 19, 20

O

Overview of the base station 11
Overview of your phone 8

P

Paging 26
Phonebook 17, 20
Predialling 17

R

Recall time 31
Recycle your batteries 6
Redial list 17, 23
Registration 32
Remote Control Access 39
Reset Unit 33
Ring Delay 39
Ring Melody 28
Ring Volume 28

S

Save a redial number 23
Store a contact 21
Switch handset on/off 19

T

Telephone answering machine 37
Text or number entry 19

U

Unmute 19
Unregister 32

V

Volume 19

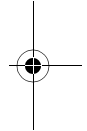
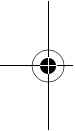
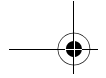

Copyright © 2007 Koninklijke Philips Electronics N.V. All rights reserved.
Trademarks are the property of Koninklijke Philips Electronics N.V. or their respective owners.
Specifications are subject to change without notice.
Document order number: **3111 285 37571** (EN)
Printed in P.R.C.

