

Color TV

Directions for Use



Read this manual first!

Congratulations on purchasing this Philips product. We've included everything you need to get started. If you have any problems, Philips Representatives can help you get the most from your new product by explaining:

- Hookups,
- First Time Setup, and
- Feature Operation.

Do not attempt to return this product to the store.

For fast help, call us first!
1-800-531-0039

Thank you for making Philips a part of your home!

Important!
Return your
Warranty
Registration Card
within 10 days.
See why inside.

Model No.: _____
Serial No.: _____

Let's make things better.



PHILIPS

Return your Warranty Registration card today to ensure you receive all the benefits you're entitled to.

Once your PHILIPS purchase is registered, you're eligible to receive all the privileges of owning a PHILIPS product. So complete and return the Warranty Registration Card enclosed with your purchase at once. And take advantage of these important benefits.

Warranty Verification

Registering your product within 10 days confirms your right to maximum protection under the terms and conditions of your PHILIPS warranty.

Owner Confirmation

Your completed Warranty Registration Card serves as verification of ownership in the event of product theft or loss.

Model Registration

Returning your Warranty Registration Card right away guarantees you'll receive all the information and special offers which you qualify for as the owner of your model.

Congratulations on your purchase, and welcome to the "family!"

PHILIPS

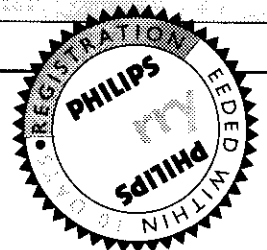

Dear PHILIPS product owner:

Thank you for your confidence in PHILIPS. You've selected one of the best-built, best-backed products available today. And we'll do everything in our power to keep you happy with your purchase for many years to come. As a member of the PHILIPS "family," you're entitled to protection by one of the most comprehensive warranties and outstanding service networks in the industry.

What's more, your purchase guarantees you'll receive all the information and special offers for which you qualify, plus easy access to accessories from our convenient home shopping network.

And most importantly you can count on our uncompromising commitment to your total satisfaction. All of this is our way of saying welcome—and thanks for investing in a PHILIPS product.

Sincerely,

Lawrence J. Blanford
President and Chief Executive Officer

P.S. Remember, to get the most from your PHILIPS product, you must return your Warranty Registration Card within 10 days. So please mail it to us right now!

Know these safety symbols



⚡ This "bolt of lightning" indicates uninsulated material within your unit may cause an electrical shock. For the safety of everyone in your household, please do not remove product covering.

⚠ The "exclamation point" calls attention to features for which you should read the enclosed literature closely to prevent operating and maintenance problems.

WARNING: TO PREVENT FIRE OR SHOCK HAZARD, DO NOT EXPOSE THIS EQUIPMENT TO RAIN OR MOISTURE.

CAUTION: To prevent electric shock, match wide blade of plug to wide slot, and fully insert.

ATTENTION: Pour éviter les chocs électriques, introduire la lame la plus large de la fiche dans la borne correspondante de la prise et pousser jusqu'au fond.

PHILIPS Visit our World Wide Web Site at <http://www.philips.com>

IMPORTANT SAFETY INSTRUCTIONS

Read before operating equipment

1. Read these instructions.
2. Keep these instructions.
3. Heed all warnings.
4. Follow all instructions.
5. Do not use this apparatus near water.
6. Clean only with a dry cloth.
7. Do not block any of the ventilation openings. Install in accordance with the manufacturers instructions.
8. Do not install near any heat sources such as radiators, heat registers, stoves, or other apparatus (including amplifiers) that produce heat.
9. Do not defeat the safety purpose of the polarized or grounding-type plug. A polarized plug has two blades with one wider than the other. A grounding type plug has two blades and third grounding prong. The wide blade or third prong are provided for your safety. When the provided plug does not fit into your outlet, consult an electrician for replacement of the obsolete outlet.
10. Protect the power cord from being walked on or pinched particularly at plugs, convenience receptacles, and the point where they exit from the apparatus.
11. Only use attachments/accessories specified by the manufacturer.
12.  Use only with a cart, stand, tripod, bracket, or table specified by the manufacturer, or sold with the apparatus. When a cart is used, use caution when moving the cart/apparatus combination to avoid injury from tip-over.
13. Unplug this apparatus during lightning storms or when unused for long periods of time.
14. Refer all servicing to qualified service personnel. Servicing is required when the apparatus has been damaged in any way, such as power-supply cord or plug is damaged, liquid has been spilled or objects have fallen into apparatus, the apparatus has been exposed to rain or moisture, does not operate normally, or has been dropped.
15. This product may contain lead and mercury. Disposal of these materials may be regulated due to environmental considerations. For disposal or recycling information, please contact your local authorities or the Electronic Industries Alliance: www.ciae.org
16. **Damage Requiring Service** - The appliance should be serviced by qualified service personnel when:
 - A. The power supply cord or the plug has been damaged; or
 - B. Objects have fallen, or liquid has been spilled into the appliance; or
 - C. The appliance has been exposed to rain; or
 - D. The appliance does not appear to operate normally or exhibits a marked change in performance; or
 - E. The appliance has been dropped, or the enclosure damaged.
17. **Tilt/Stability** - All televisions must comply with recommended international global safety standards for tilt and stability properties of its cabinet design.
 - Do not compromise these design standards by applying excessive pull force to the front, or top, of the cabinet which could ultimately overturn the product.
 - Also, do not endanger yourself, or children, by placing electronic equipment/toys on the top of the cabinet. Such items could unsuspectingly fall from the top of the set and cause product damage and/or personal injury.
18. **Wall or Ceiling Mounting** - The appliance should be mounted to a wall or ceiling only as recommended by the manufacturer.
19. **Power Lines** - An outdoor antenna should be located away from power lines.
20. **Outdoor Antenna Grounding** - If an outside antenna is connected to the receiver, be sure the antenna system is grounded so as to provide some protection against voltage surges and built up static charges.

Section 810 of the National Electric Code, ANSI/NFPA No. 70-1984, provides information with respect to proper grounding of the mast and supporting structure, grounding of the lead-in wire to an antenna discharge unit, size of grounding connectors, location of antenna-discharge unit, connection to grounding electrodes, and requirements for the grounding electrode. See Figure below.
21. **Object and Liquid Entry** - Care should be taken so that objects do not fall and liquids are not spilled into the enclosure through openings.

Note to the CATV system installer: This reminder is provided to call the CATV system installer's attention to Article 820-40 of the NEC that provides guidelines for proper grounding and, in particular, specifies that the cable ground shall be connected to the grounding system of the building, as close to the point of cable entry as practical.

Example of Antenna Grounding as per NEC - National Electric Code

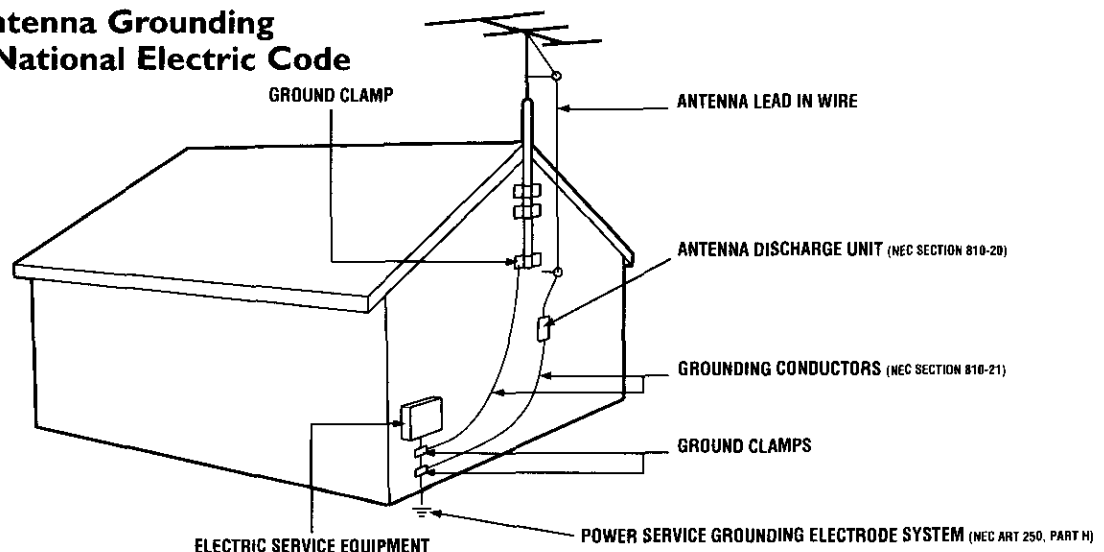

CONTENTS

INTRODUCTION

Welcome/Registration of Your TV	2
Safety/Precautions	2-3
Features	5



AUDIO/VIDEO INPUT JACKS

Jack Panel descriptions and required cables	6
Using the AV 1 Input Jacks	7
Using the AV 2 Input Jacks	8
Using the Side (AV 3) Input Jacks	9
Using the AV 4 Input Jacks	10
Using the Component Video Input Jacks (CVI)	11
Using the S-Video Input Jack	12
Using the Monitor Output Jacks	13



PICTURE MENU CONTROLS

Adjusting the Brightness Control	14
Adjusting the Color Control	14
Adjusting the Picture Control	14
Adjusting the Sharpness Control	14
Adjusting the Tint Control	14
How to set the Color Temp Control	14
How to use the Digital Options Control	15
How to set the Dyn(amic) Contrast Control	16



SOUND MENU CONTROLS

Adjusting the Treble Control	17
Adjusting the Bass Control	17
Adjusting the Balance Control	17
How to use the AVL control	18
How to use the Incr.(edible) Surround Control	19
How to set the Stereo Control	19
How to set the TV to receive Secondary Audio Programming, also known as the SAP Control	20
How to set the Audio Out Control	21
How to turn the TV speakers on or off using the Speaker Control	22



FEATURE MENU CONTROLS

How to use the Timer controls:

Setting the TV Clock using the Time Control	23
Setting a time for the TV to turn itself on using the Start Time Control	24
Setting a time for the TV to turn itself off using the Stop Time Control	25
Setting the TV to start on a specific channel using the Channel Control	26
How to activate the controls using the Activate Control	27
How to view the time using the Display Control	28
How to activate the Active Control™	29

How to use the AutoLock™ Controls:

Understanding the AutoLock™ Feature	30
Setting up an AutoLock™ Access Code	31
How to Block Channels	32
How to Clear All blocked channels at the same time	33
Blocking programming based on Movie Ratings	34
Blocking programming based on TV Ratings	35
AutoLock™ Blocking Options - Blocking Control	36
AutoLock™ Blocking Options - No Rating Control	37
How to review the AutoLock™ Control Status	38
How to use the Closed Captioning Control	39
How to change the screen (size) format using the Format Control	40



REMOTE CONTROL RELATED FEATURES

How to set the Sleep Timer Control	41
How to Use the Freeze Control	42
Using the AutoPicture™ Control	43
Using the AutoSound™ Control	44
Using the Surf Control (and Alternate Channel)	45
Using the Remote Control with accessory devices	
Direct Access Method	46
Code-Entry Method	47
Search Method	48
Direct-Entry Code list for accessory devices	49-50
Remote Control VCR Specific Button	51



GENERAL INFORMATION

Care and Cleaning	52
Troubleshooting	52
Glossary of terms	53
Index	54
Factory Service Locations	55
Limited Warranty	56

QUICK USE AND SETUP GUIDE

Refer to the simple **Quick Use and Setup Guide** (supplied with your TV) for details on the following:

- Basic TV connections
- Basic TV and remote-control operation
- Onscreen menu navigation
- How to use the Installation features

Language, Tuner Mode, Auto Program, Channel Edit, Name, and AutoChron™

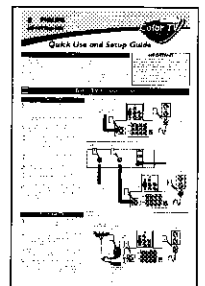

FEATURES

Active Control™ continuously measures and corrects all incoming signals to help provide the best picture quality. This feature monitors and corrects both the sharpness control and noise reduction control.

Audio/Video Jack Panel allows direct connections with VCRs, DVDs, or other devices, providing quality TV picture and sound playback.

Audio Volume Leveler (AVL) Control keeps the TV sound at an even level. Peaks and valleys that occur during program changes or commercial breaks are reduced, making for a more consistent, comfortable sound.

AutoChron™ automatically sets the right time of day and maintains it with digital precision through brownouts, power failures, and even Daylight Savings Time adjustments.

AutoLock™ allows you to block the viewing of certain channels or programs with certain ratings if you do not want your children to view inappropriate materials.

Auto Programming scans (when activated) for all available channels from regular antenna or cable signals and stores only active broadcast stations in the TV's memory.

AutoPicture™ allows you to change the picture settings (color, tint, contrast, etc.) for various types of programming, such as sports, movies, multimedia (games), or weak signals with the push of one button.

AutoSound™ allows you to select from three factory-set controls and a personal control that you set according to your own preferences through the onscreen Sound menu. The three factory-set controls (Voice, Music, and Theatre) enable you to tailor the TV sound so as to enhance the particular programming you are watching.

Channel Edit allows you to add or delete channels from the list stored in the TV's memory. Channel Edit makes it easy to limit or expand the number of channels that are available to you when you press the Channel (+) or (-) buttons on your remote control.

Closed Captioning allows the viewer to read TV program dialogue or voice conversations as onscreen text.

Dynamic Contrast helps to sharpen the picture quality by improving the contrast between the darkest and brightest parts of the picture.

Eye Fidelity (also known as Digital Options) give a choice of two different scanning technics – Progressive Scan or Interlaced. Progressive Scan doubles the number of visible lines per field by displaying all picture frame lines at once, eliminating any picture flicker. The Interlaced mode provides a double vertical display scan, which reduces annoying motion sweeps. The Interlaced mode will also smooth out the jagged lines sometimes seen on the edges of curved or angled surfaces.

Infrared Remote Control works your TV and other remote-controlled devices, such as VCRs, DVD players, cable converters, and satellite receivers.

Onscreen Menu shows helpful messages and instructions for setting TV feature controls (can be viewed in English, French, or Spanish).

Sleep Timer automatically turns the TV OFF after a set amount of time that you choose.

Standard Broadcast (VHF/UHF) or Cable TV (CATV) channel capability allows for viewing by antenna or cable.

Stereo capability, including a built-in audio amplifier and twin-speaker system, allows for the reception of TV programs broadcast in stereo sound.

Surf Button allows you to easily switch among only the channels that are of interest to you (the ones that you have programmed into the TV's Surf control through the onscreen menu).

Timer allows you to set your TV to turn itself ON and OFF once or daily like an alarm clock.

Items Included with This TV

As you unpack your TV, please note that this *Directions for Use* manual contains safety-tip information and **Factory Service Center locations, as well as a Warranty Registration Card, remote control, and batteries for use with the remote control.**

Please take a few minutes to complete your registration card. The serial number for the TV is on the rear of the set. Refer to the back of this manual for instructions in the cleaning and care of the TV.

END-OF-LIFE DISPOSAL

Your new television and its packing contain materials that can be recycled and reused. Specialized companies can recycle your product to increase the amount of reusable materials and minimize the amounts that need to be properly disposed.

Your product also uses batteries that should not be thrown away when depleted, but should be handed in and disposed of as small chemical waste.

When you replace your existing equipment, please find out about the local regulations regarding disposal of your old television, batteries, and packing materials.



As an Energy Star® Partner, Philips Consumer Electronics has determined this product meets the Energy Star® guidelines for energy efficiency. Energy Star® is a U.S. registered mark. Using products with the Energy Star® label can save energy. Saving energy reduces air pollution and lowers utility bills.

Active Control, APAC, AutoPicture, AutoSound, AutoChron, and Incredible Surround are trademarks of Philips Consumer Electronics Company. Copyright 2001 Philips Consumer Electronics.

*Manufactured under license from Dolby Laboratories. "Dolby" and the double-D symbol are trademarks of Dolby Laboratories.



JACK PANEL DESCRIPTIONS AND REQUIRED CABLES

The television is equipped with external input and output jacks for use with optional accessory devices such as VCRs, DVD Player, Gaming Units, Video Cameras, etc. The following gives a brief explanation of the different types of jacks available and the type of cables needed to make connections.

- 1** **75Ω RF** - Cable/Antenna Input connection jack. Located on the back of the television.
- 2** **AV 1 in** - Audio/Video connection jacks. Located on the back of the television. Along with Component Video Inputs.
- 3** **AV 2 in** - Audio/Video Input connection jacks. Located on the back of the television.
- 4** **S-Video Input jack** - Used with the AV 2 in Audio Left and Right Input jacks. Located on the back of the television.
- 5** **Monitor Out** - Audio/Video Output connection jacks. Located on the back of the television.
- 6** **AV 4 in** - Component Video, VGA (RGB), and Audio Input connection jacks. Located on the back of the television.
- 7** **SIDE (AV 3)** - Audio/Video Input jacks, plus a Headphone jack located on the side of the cabinet.

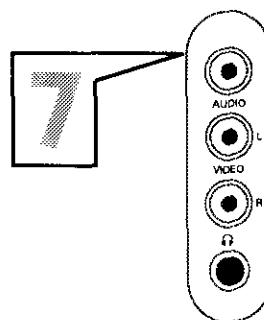
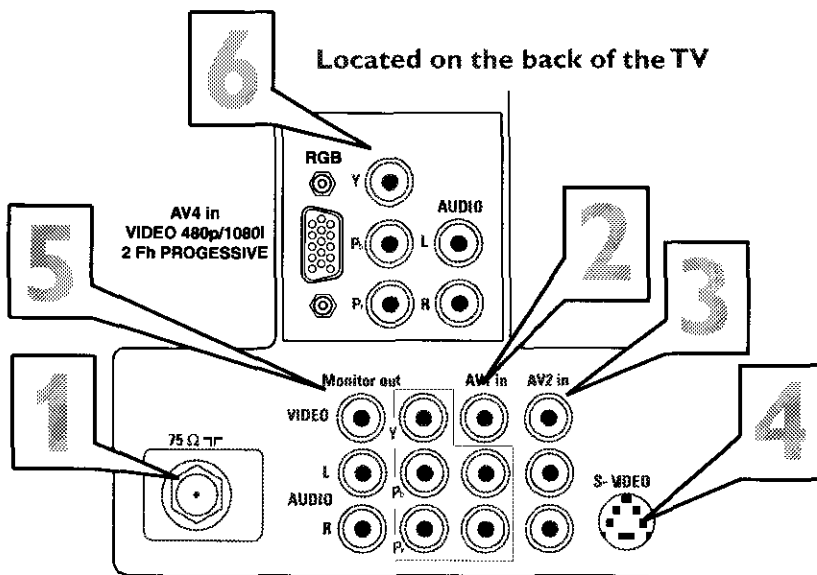

Located on the side of the TV

Cable Descriptions:



A 75-ohm **coaxial cable** connects signals from an antenna or a cable TV company to the antenna jack on the back of the TV. Coaxial cables use "F" connectors.

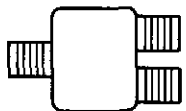

A **two-way signal splitter** enables you to take a single antenna or cable TV signal and supply it to two different inputs.

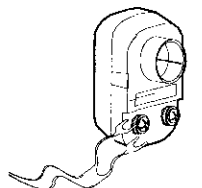

A **300- to 75-ohm twin-lead adapter** accepts the antenna cables (called twin-lead wires) from an antenna, allowing you to connect the antenna signal to the TV.

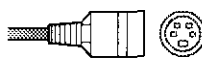

An **S-Video cable** provides better picture performance than regular (composite) video connections. S-Video cables can be used only with S-Video-compatible accessory devices. You must also connect the left and right audio cables to the AV 2 Audio in jacks because the S-Video jack carries only the picture signal, not the sound.



Yellow - Video



White - Audio Left



Red - Audio Right

Video and audio cables with standard RCA (phono) connectors connect the video and audio jacks of accessory devices such as VCRs and DVD players to the jacks on the TV.

These connectors are usually color coded. The jacks on your TV are also color coded to match the colors of the connectors. Yellow for video (composite) and Red and White for the right and left audio channels. The video cables used to connect component video or RGB (high-resolution) jacks are color coded red, green, and blue.

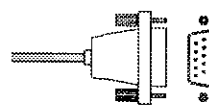

An **VGA (HD15) cable** makes a VGA (RGB) connection to the HD INPUT-AV 4 jack on the rear of the TV.

USING THE AV 1 INPUT JACKS

The TV's audio/video input jacks are for direct picture and sound connections between the TV and a VCR (or similar device) that has audio/video output jacks. Follow the easy steps below to connect your accessory device to the AV 1 Input Jacks located on the back of the TV.

- 1 Connect the VIDEO (yellow) cable to the VIDEO AV1 in jack on the back of the TV.
- 2 Connect the AUDIO (red and white) cables to the AUDIO (left and right) AV1 in jacks on the rear of the TV.
- 3 Connect the VIDEO (yellow) cable to the VIDEO OUT jack on the back of the VCR.
- 4 Connect the AUDIO (red and white) cables to the AUDIO (left and right) OUT jacks on the rear of the VCR.
- 5 Turn the VCR (accessory device) and the TV ON.
- 6 Press the AV button on the remote control to select the AV1 channel. AV1 will appear in the upper left corner on the TV screen.
- 7 With the VCR (or accessory device) ON and a prerecorded tape (CD, DVD, etc.) inserted, press the PLAY button to view the tape on the television.

CHECK IT OUT

Repeatedly pressing the AV button on the remote control will toggle the picture source from the current channel, then AV1, CVI, AV2, SIDE (AV3), and the AV4 Input Jack connections.

NOTE: Repeatedly pressing the AV button on the remote control will toggle the picture source from the current channel, the AV1 channel, then the CVI channel, then the AV2 channel, then the SIDE (AV3) channel and the AV4 channel. After the AV4 channel, the AV button will select the current channel again.

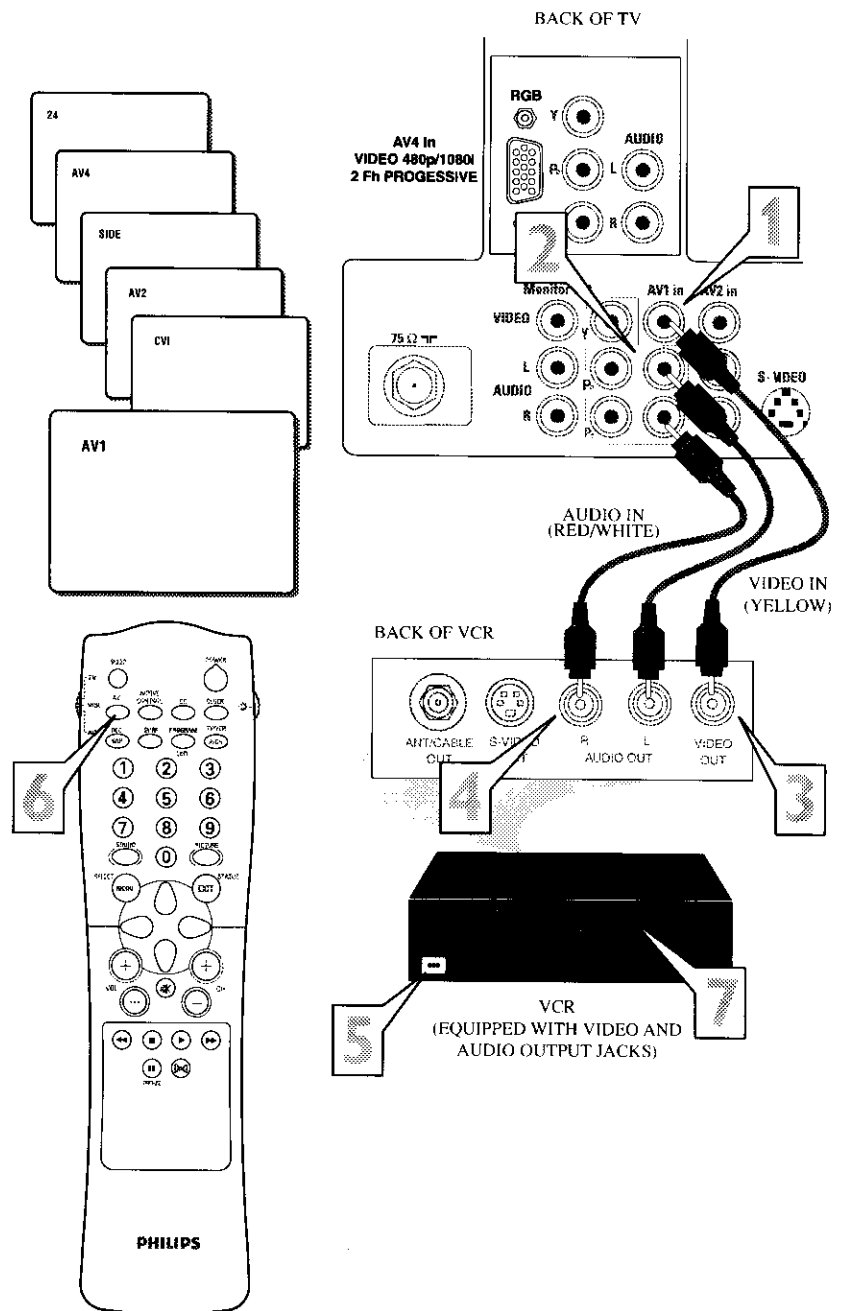



USING THE AV 2 INPUT JACKS

The TV's audio/video input jacks allow you to connect multiple accessory devices at one time to different sets of input jacks. Follow the easy steps below to connect an additional accessory device to the AV 2 Input Jacks located on the back of the TV.

- 1 Connect the VIDEO (yellow) cable to the VIDEO AV2 in jack on the back of the TV.
- 2 Connect the AUDIO (red and white) cables to the AUDIO (left and right) AV2 in jacks on the rear of the TV.
- 3 Connect the VIDEO (yellow) cable to the VIDEO OUT jack on the back of the VCR.
- 4 Connect the AUDIO (red and white) cables to the AUDIO (left and right) OUT jacks on the rear of the VCR.
- 5 Turn the VCR (accessory device) and the TV ON.
- 6 Press the AV button on the remote control to select the AV2 channel. AV2 will appear in the upper left corner on the TV screen.
- 7 With the VCR (or accessory device) ON and a prerecorded tape (CD, DVD, etc.) inserted, press the PLAY button to view the tape on the television.

NOTE: Repeatedly pressing the AV button on the remote control will toggle the picture source from the current channel, the AV1 channel, then the CVI channel, then the AV2 channel, then the SIDE (AV3) channel and the AV4 channel. After the AV4 channel, the AV button will select the current channel again.

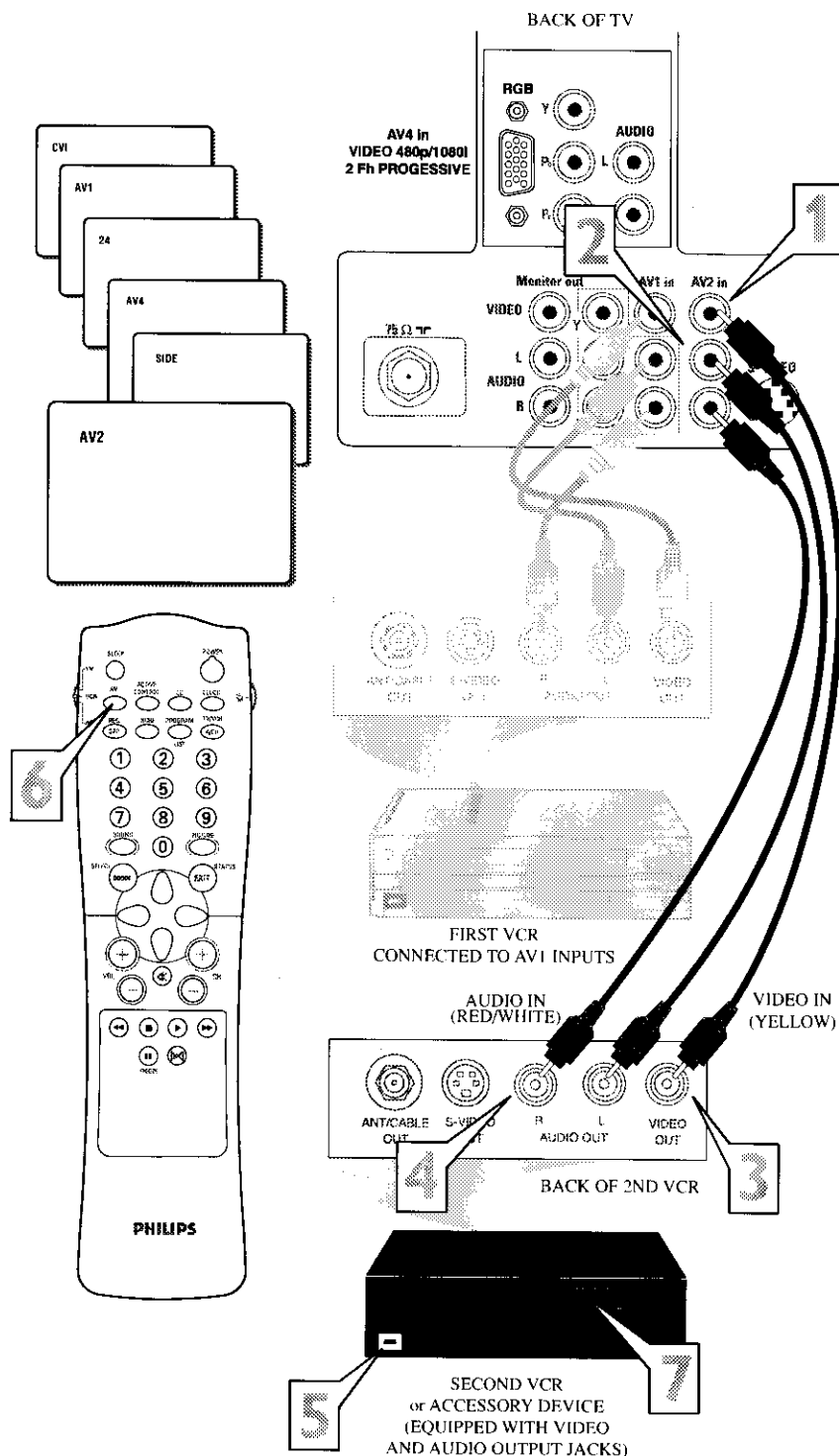

USING THE SIDE (AV 3) INPUT JACKS



This television has input jacks conveniently located on the side of the cabinet. These jacks are for easy hook-ups (without having to move around to the back of the TV) for cameras, gaming units, and other accessory devices that wouldn't be connected permanently. Follow the easy steps below to connect your accessory device to the SIDE (AV 3) Input Jacks located on the right side of the TV.

- 1 **Connect the VIDEO (yellow) cable** to the VIDEO in jack on the side of the TV.
- 2 **Connect the AUDIO (red and white) cables** to the AUDIO (left and right) in jacks on the side of the TV.
- 3 **Connect the VIDEO (yellow) cable** to the VIDEO OUT jack on the back of the camera (or accessory device).
- 4 **Connect the AUDIO (red and white) cables** to the AUDIO (left and right) OUT jacks on the rear of the camera (or accessory device).
- 5 **Turn the camera (or accessory device) and the TV ON.**
- 6 **Press the AV button** on the remote control to select the SIDE channel. SIDE will appear in the upper left corner on the TV screen.
- 7 **With the camera (or accessory device) ON and a prerecorded tape (CD, DVD, Game Card, etc., depending on type of accessory device) inserted, press the PLAY button** to view the tape on the television.

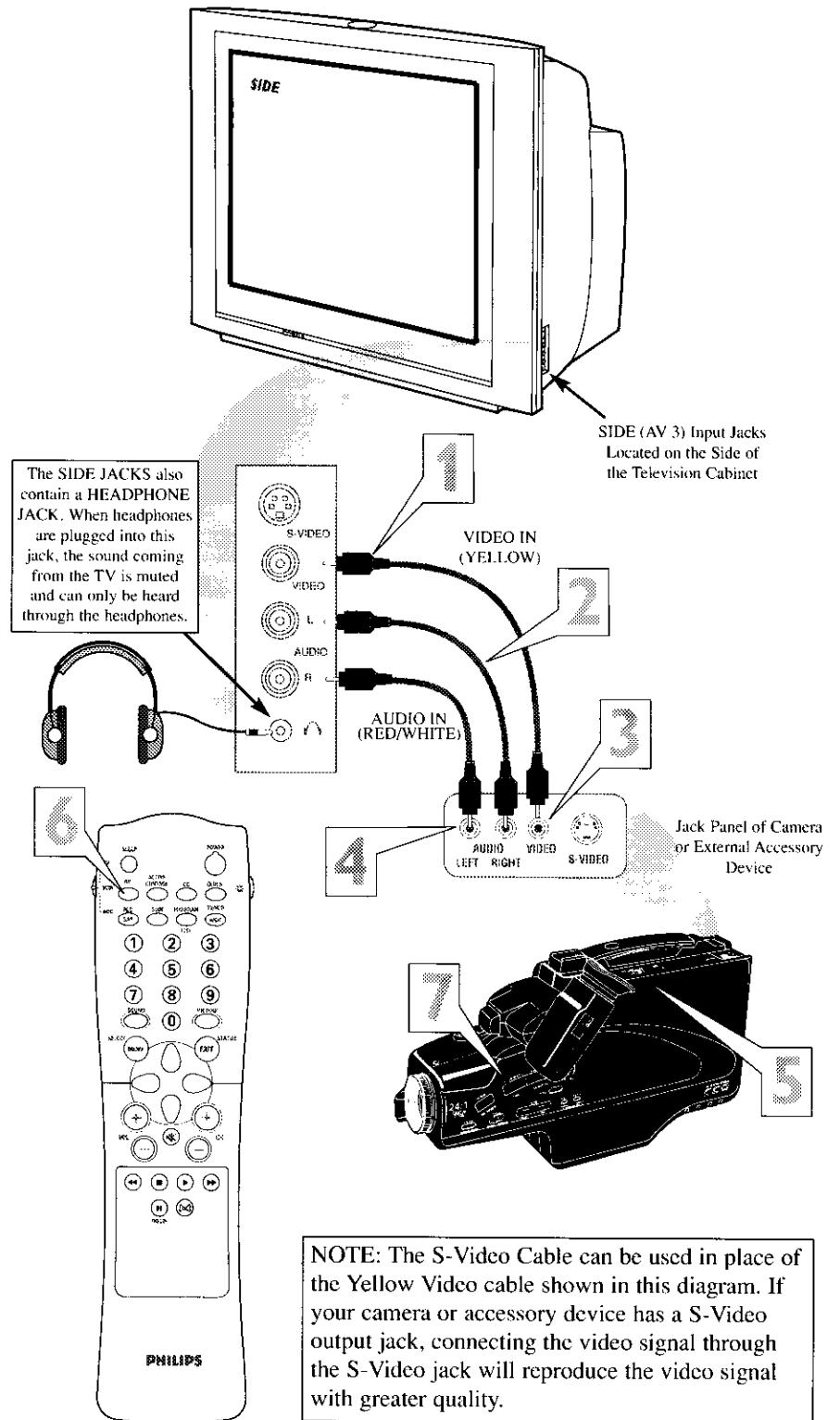



USING THE AV 4 INPUT JACKS

The AV4 Input Jacks provide Both Component and VGA Video Inputs at 1080i or 480p, for accessory like HD Receiver and Digital DVD Players. Using the color difference signals (Pb, Pr) and the luminance (Y) signal will improve color bandwidth information.

Connecting a Digital device using the COMPONENT VIDEO Inputs:

- 1 Connect the Component (Y, Pb, Pr) Video OUT jacks from the DVD player (or similar device) to the (Y, Pb, Pr) AV4 in(put) jacks on the TV.
- 2 Connect the red and white AUDIO CABLES to the Audio (left and right) output jacks on the rear of the accessory device to the Audio (L and R) AV4 in(put) jacks on the TV.
- 3 Turn the TV and the DVD (or digital accessory device) ON.
- 4 Press the AV button on the remote to tune to the AV4 channel.
- 5 Press the PLAY button on the DVD (or digital accessory device) to view the program on the television.

Connect an HD Receiver to the VGA Input:

Please refer to your Receiver's Owner's Manual for more detailed hookup options.

- 6 If using a Satellite Dish, Cable signal or Antenna signal, connect the 75Ω round cable from a Satellite Dish to the SATELLITE IN and/or the Cable and Antenna signals to the ANTENNA "A" or "B" IN on the back of the HD Receiver.
- 7 Connect another 75Ω round cable from the OUT TO TV jack on the HD Receiver to the 75Ω IN on the back of the TV.
- 8 Connect a VGA cable from the VGA OUT on the HD Receiver to the AV4 VGA Input jack on the back of the TV.
- 9 Connect the Audio L(ef) and R(ight) cables from the AUDIO Outputs on the HD Receiver to the AV4 AUDIO Inputs on the back of the TV.

With both the HD Receiver and the television ON, Press the AV button on the remote to tune to the AV 4 Channel and view the video input from the VGA supplied signal.

10

Using the AV4 Component Video Inputs

Note: If the AV4 channel is tuned and no signal connection present, the screen could jump or flash.

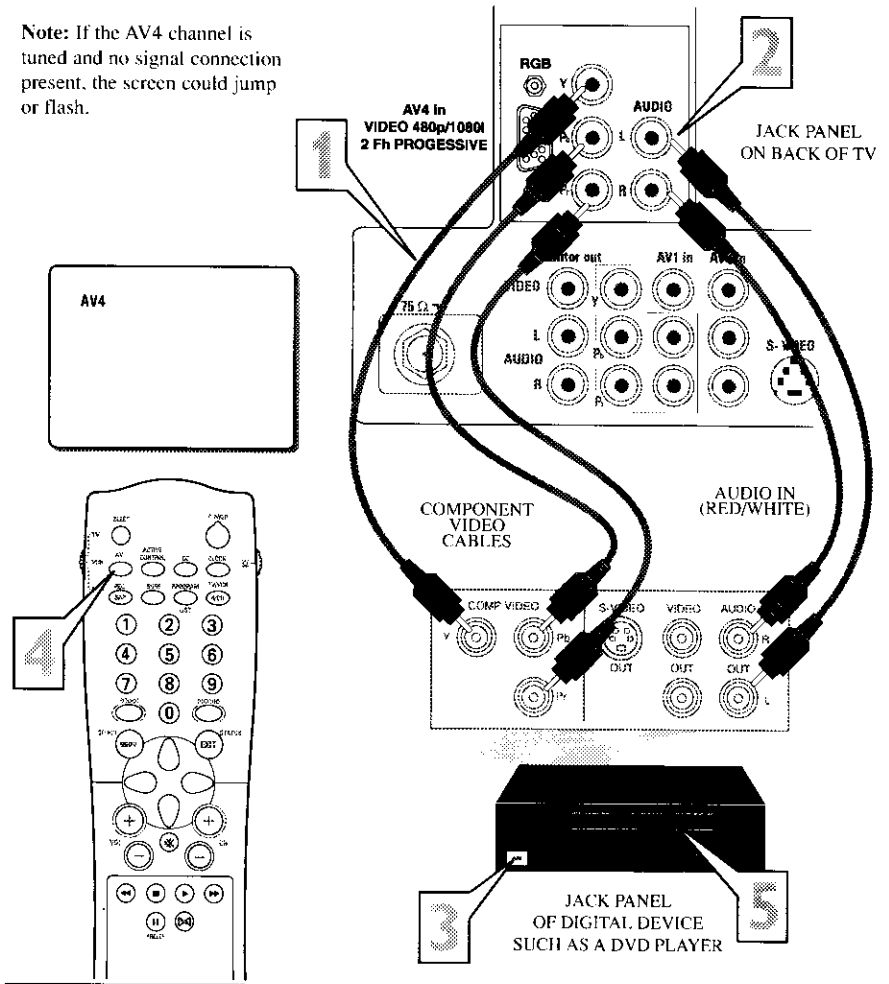

Using the VGA Input and a HD Receiver

Note: This is a very basic hookup, please refer to you HD Receiver's (or accessory device's) Owner's Manual for detailed hookup instructions.

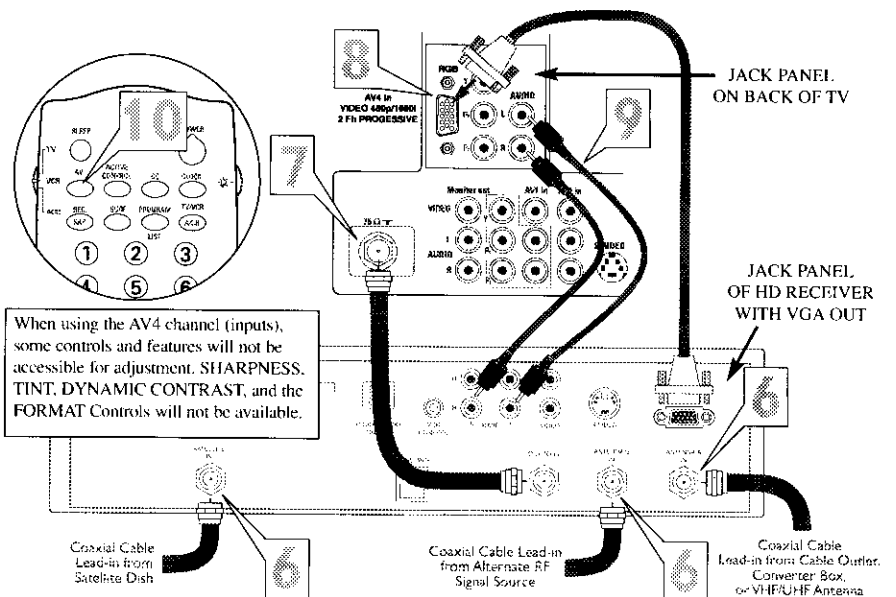

USING THE COMPONENT VIDEO INPUT (CVI) JACKS

Component Video inputs provide for the highest possible color and picture resolution in the playback of digital signal source material, such as with DVD players. The color difference signals (Pb, Pr) and the luminance (Y) signal are connected and received separately, which allows for improved color bandwidth information (not possible when using composite video or S-Video connections).

- 1 **Connect the Component (Y, Pb, Pr) Video OUT** jacks from the DVD player (or similar device) to the (Y, Pb, Pr) in(put) jacks on the TV. When using the Component Video Inputs, it is best not to connect a signal to the AV1 Video Input.
 - 2 **Connect the red and white AUDIO CABLES** to the Audio (left and right) output jacks on the rear of the accessory device to the Audio (L and R) AV1 in(put) jacks on the TV.
 - 3 **Turn the TV and the DVD (or digital accessory device) ON.**
 - 4 **Press the AV button or the CH +, - buttons** to scroll the available channels until CVI appears in the upper left corner of the TV screen.
 - 5 **Slide the TV/VCR/ACC Switch to the ACC position.**
- NOTE:** The remote control may have to be programmed to operate your accessory device. Please refer to the Using the Remote control with Accessory Devices section starting on page 46.
- 6 **Insert a DVD disc into the DVD player and press the PLAY ► button on the remote.**

The CVI connection will be dominate over the AV1 Video Input. When a Component Video Device is connected as described, it is best not to have a video signal connected to the AV1 Video Input jack.

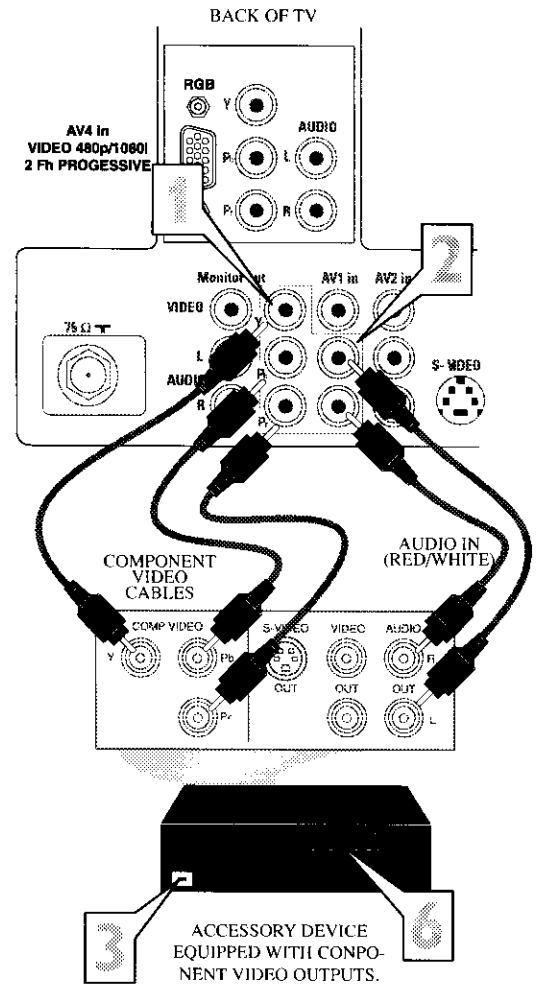
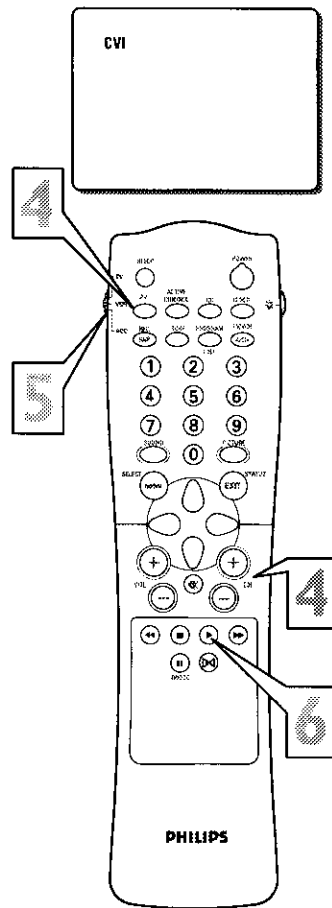

HELPFUL HINT

The description for the component video connectors may differ depending on the DVD player or accessory digital source equipment used (for example, Y, Pb, Pr; Y, B-Y, R-Y; Y, Cr, Cb). Although abbreviations and terms may vary, the letters *b* and *r* stand for the blue and red color component signal connectors, and *Y* indicates the luminance signal. Refer to your DVD or digital accessory owner's manual for definitions and connection details.



USING THE S-VIDEO INPUT JACKS

The S(uper)-Video connection on the rear of the TV can provide you with better picture detail and clarity for the playback of accessory sources such as DBS (digital broadcast satellite), DVD (digital video discs), video games, and S-VHS VCR (video cassette recorder) tapes than the normal antenna picture connections.

NOTE: The accessory device must have an S-VIDEO OUT(put) jack in order for you to complete the connection on this page.

- 1 Connect the S-VIDEO CABLE to the S-VIDEO input jack on the rear of the television.
- 2 Connect the AUDIO (red and white) cables to the AUDIO AV2 in jacks on the rear of the TV.
- 3 Connect the S-VIDEO CABLE to the S-VIDEO output jack on the accessory device.
- 4 Connect the red and white AUDIO cables to the AUDIO (left and right) output jacks on the rear of the accessory device.
- 5 Turn the VCR, DVD or other accessory device ON.
- 6 Press the AV button on the remote control to select the AV2 channel. AV2 will appear in the upper left corner on the TV screen.
- 7 With the VCR (or accessory device) ON and a prerecorded tape inserted, press the PLAY button to view the tape on the television.

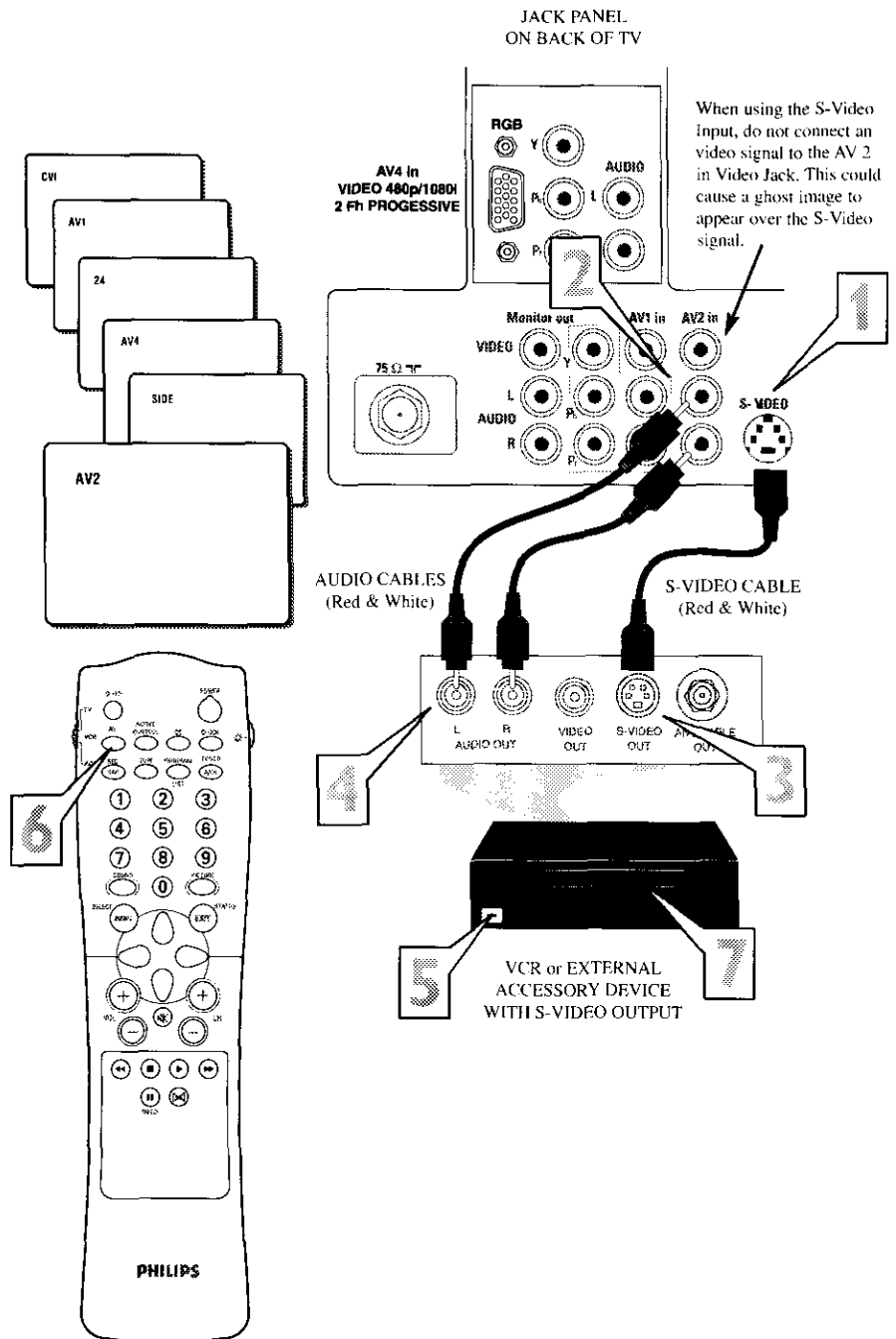

USING THE MONITOR OUTPUT JACKS



The Audio/Video (Monitor) Output jacks are great for recording with a VCR or used to connect an external audio system for better sound reproduction.

For Audio System Connection:

- 1 Connect one end of the R(ight) and L(ef) AUDIO (Monitor Out) jacks on the TV to the R and L audio input jacks on your amplifier or sound system. Set the audio system's volume to a normal listening level.

NOTE: Refer to page 21 to set the TV's Audio Out Control to VARIABLE if you want to control the volume of the audio system with the TV remote control. (Set the control to FIXED if you want to control the volume from the audio system.)

- 2 Turn the TV and audio system ON. You can now adjust the sound level coming from the audio system with the VOLUME (+) or (-) button on the TV or remote control.

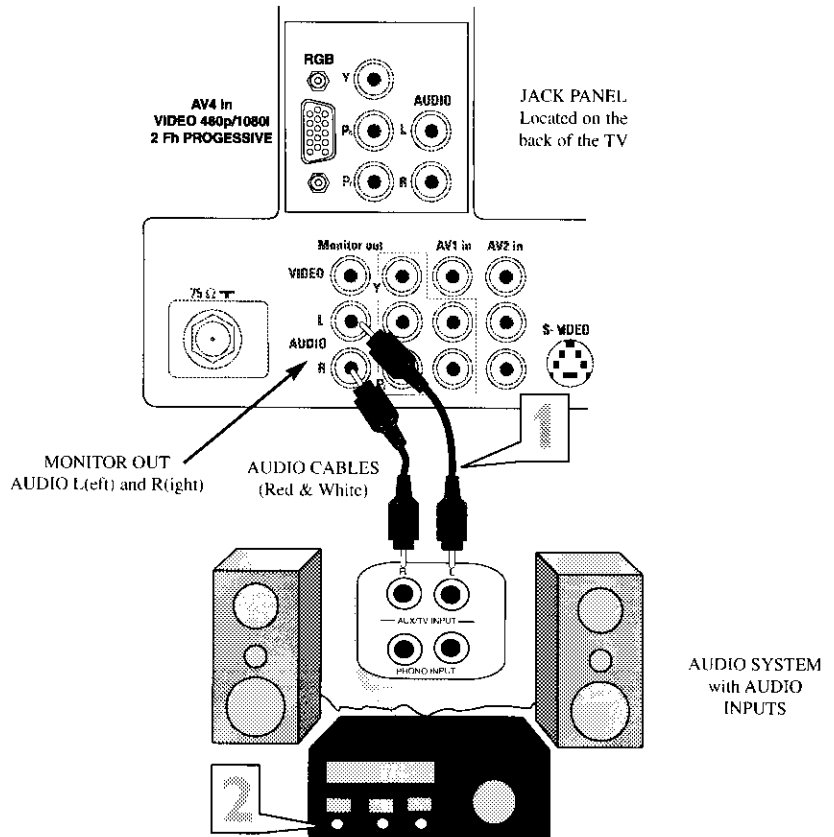

For Second VCR Connection:

NOTE: Refer to page 7 for the proper hookup of the first VCR. Follow the instructions on how to tune to the AV 1 channel to view a pre-recorded tape.

The following steps allow you to connect a second VCR to record the program while your watching it.

- 3 Connect one end of the yellow Video Cable to the Monitor Out VIDEO plug. Connect the other end to the VIDEO IN plug on the second VCR.
- 4 Connect one end of the red and white Audio cable from the Monitor Out AUDIO L and R plugs on the TV to the AUDIO IN plugs on the VCR.
- 5 Turn the Second VCR ON, insert a black VHS tape and it's ready to record what's being viewed on the TV screen.

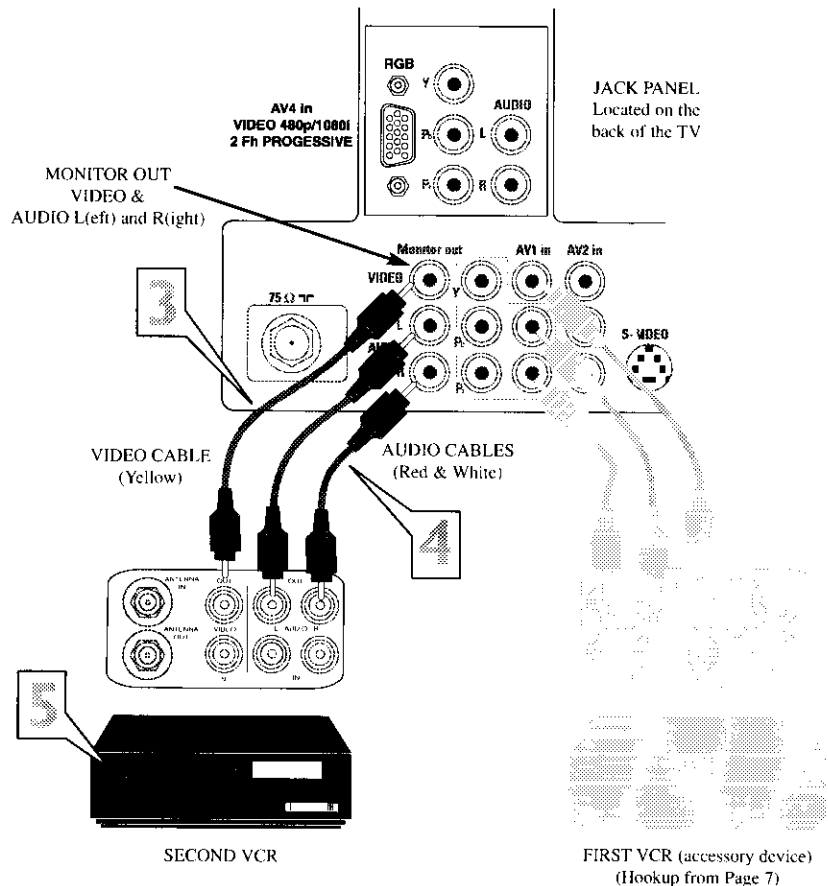



ADJUSTING THE PICTURE CONTROLS

To adjust your TV picture controls, select a channel and follow these steps.

- 1 Press the **MENU** button on the remote control to show the onscreen menu. **PICTURE** will be highlighted.
- 2 Press the **CURSOR RIGHT** button and the menu will shift to the left. **BRIGHTNESS** will be highlighted and an adjustment bar will be shown to the right.
- 3 Use the **CURSOR LEFT** or **CURSOR RIGHT** button to adjust the **BRIGHTNESS** level of the picture.
- 4 After adjusting the **BRIGHTNESS** control, press the **CURSOR DOWN** button to select another picture adjustment: **COLOR**, **PICTURE**, **SHARPNESS**, **TINT**, OR **COLOR TEMP**. Press the **CURSOR LEFT** or **CURSOR RIGHT** button to adjust the selected control.

NOTE: The menu will show only five items at a time, so you will need to continue scrolling with the **CURSOR DOWN** button to adjust the **TINT** and **COLOR TEMP**.

- 5 Press the **STATUS/EXIT** button to remove the menu from the screen.

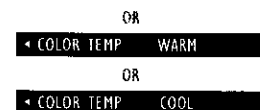
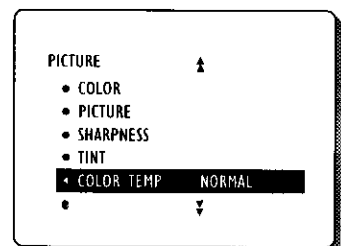
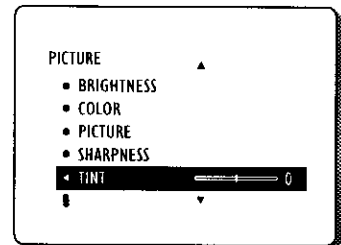
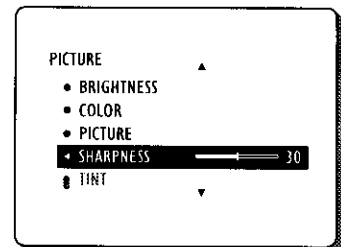
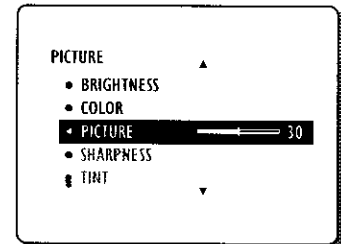
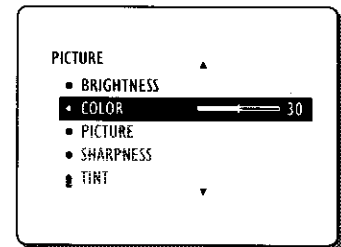
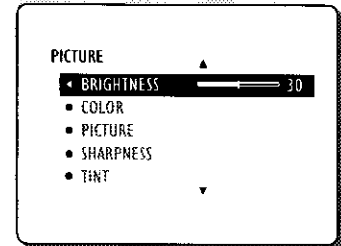
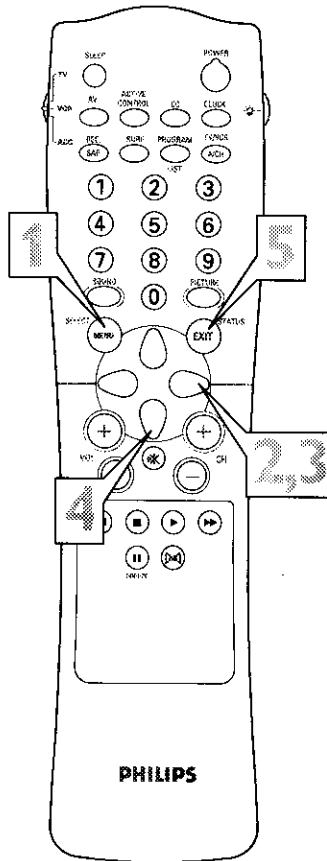
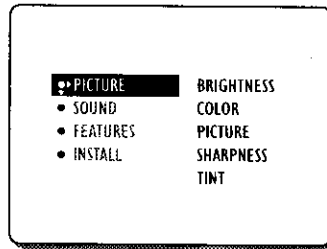

HELPFUL HINT

Remember, when the bar scale is centered , the control settings are at normal, mid-range levels. Picture adjustments are described here.

NOTE: The **SHARPNESS** and **TINT** Controls will not be available for adjustments when tuned to the **AV4** Inputs (**AV4** Channel) and **CVI** Inputs (**CVI** Channel).

BRIGHTNESS – adds or subtracts light from the darkest part of the picture.

COLOR – adds or eliminates color.

PICTURE – improves the detail of the lightest parts of the picture.

SHARPNESS – improves the detail in the picture.

TINT – adjusts the picture to obtain natural skin tones.

COLOR TEMP offers **NORMAL**, **COOL**, or **WARM** picture preferences.

NORMAL – keeps whites, white.

COOL – makes whites, bluish.

WARM – makes whites, reddish.

HOW TO USE THE DIGITAL OPTIONS CONTROL



The Digital Options (Eye Fidelity) control gives you a choice between two different picture scanning modes: Progressive Scan and Interlaced (1050i).

Progressive Scan doubles the number of picture lines, eliminating line flicker and providing a jitter-free picture.

Interlaced (1050i mode) improves the appearance of onscreen motion. All 'Picture Adjustment Controls' stay controllable, including the Active Control. It also helps smooth out jagged lines that are sometimes seen on curved and angled surfaces in the picture.

- 1 Press the **MENU** button on the remote to show the onscreen menu. PICTURE will be highlighted.
- 2 Press the **CURSOR RIGHT** button and the menu will shift to the left. BRIGHTNESS will be highlighted and an adjustment bar will be shown to the right.
- 3 Press the **CURSOR DOWN** button repeatedly until the Digital Options control is highlighted.
- 4 Press the **CURSOR RIGHT** or **LEFT** button until you select the option you want, either PROGRESSIVE or 1050i.
- 5 Press the **STATUS/EXIT** button to remove the menu from the screen.

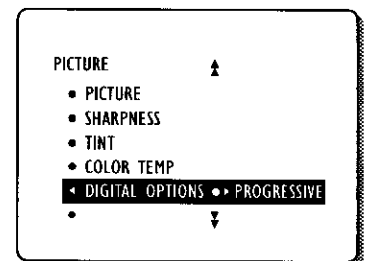
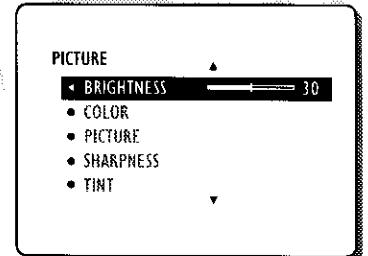
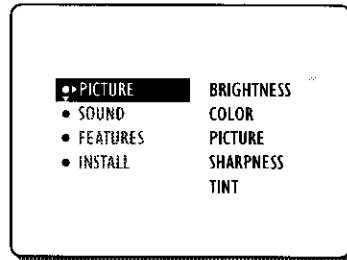

OR

◀ DIGITAL OPTIONS ▶ 1050i LINES

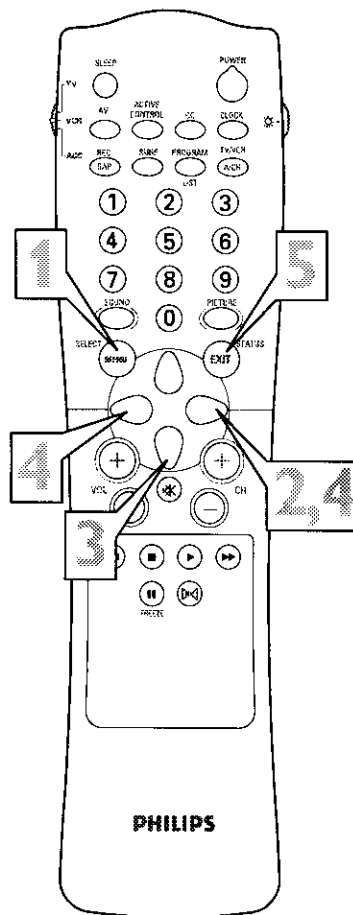

HELPFUL HINT

The Digital Options (Eye Fidelity) Control is not available for use with the AV 4 input jacks.



HOW TO SET THE DYNAMIC CONTRAST CONTROL

The Dynamic Contrast control allows you to sharpen the picture quality by making dark portions of the picture darker and light portions of the picture more noticeable. Normally, you will probably want to select MED. In certain circumstances, however, you may prefer MIN or MAX.

- 1 Press the **MENU** button on the remote to show the onscreen menu. PICTURE will be highlighted.
- 2 Press the **CURSOR RIGHT** button and the menu will shift to the left. BRIGHTNESS will be highlighted and an adjustment bar will be shown to the right.
- 3 Press the **CURSOR DOWN** button repeatedly until the DYN. CONTRAST control is highlighted.
- 4 Press the **CURSOR RIGHT** or **LEFT** button until you select the option you want, either OFF, MIN, MED, or MAX.
- 5 Press the **STATUS/EXIT** button to remove the menu from the screen.

HELPFUL HINT

The Dynamic Contrast control is not available for use with the AV 4 Inputs (AV4 Channel).

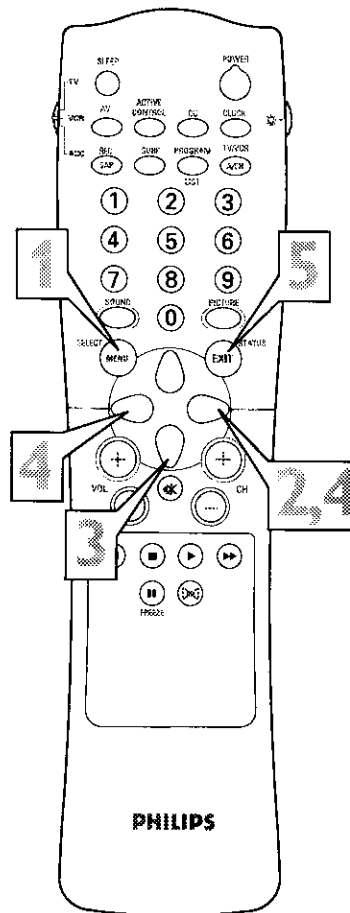
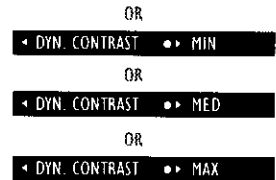
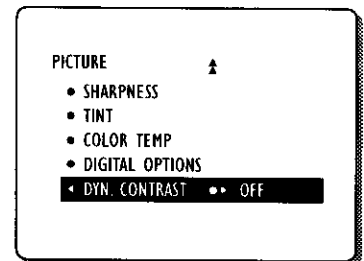
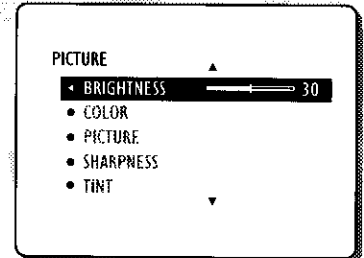
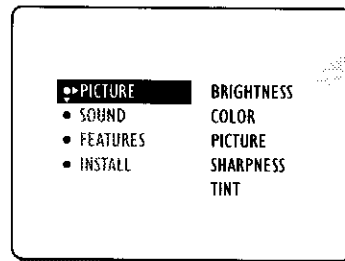

ADJUSTING THE TREBLE, BASS, AND BALANCE CONTROLS

Besides the normal volume level control, your TV also has individual sound-adjustment controls. The **TREBLE** (high frequency), **BASS** (low frequency), and Speaker **BALANCE** may all be used to adjust the sound playback of TV programs.

- 1 Press the **MENU** button on the remote control to show the onscreen menu.
- 2 Press the **CURSOR DOWN** button once to highlight **SOUND**.
- 3 Press the **CURSOR RIGHT** button and the menu will shift to the left. **TREBLE** will be highlighted and an adjustment bar will be shown to the right.
- 4 Use the **CURSOR RIGHT** or **CURSOR LEFT** button to adjust the **TREBLE** (high frequency) level of the television's sound.
- 5 After adjusting the **TREBLE** control, press the **CURSOR DOWN** button to select another sound adjustment: **BASS** or **BALANCE**.
- 6 Press the **CURSOR RIGHT** or **CURSOR LEFT** button to adjust the selected control.
- 7 Press the **STATUS/EXIT** button to remove the menu from the screen.

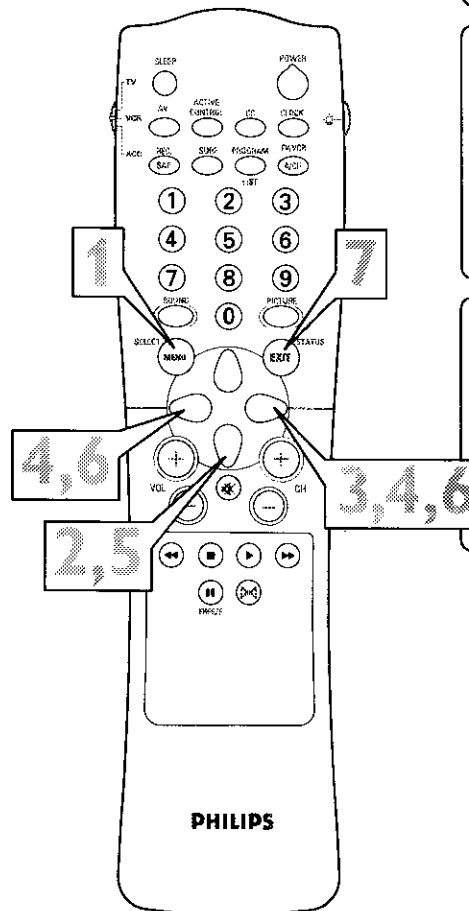
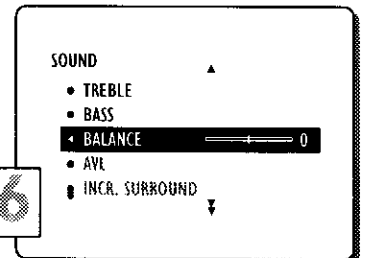
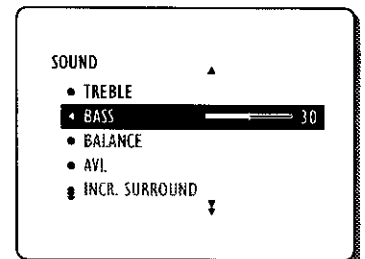
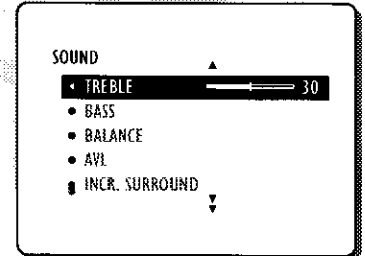
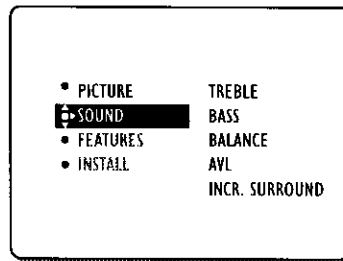

HELPFUL HINT

Remember, when the bar scale is centered, speaker **BALANCE** is centered between the TV's left and right side speakers.



HOW TO USE THE AVL CONTROL

In most cases, the volume levels coming from broadcast programming or commercials are never the same. With the AVL (Audio Volume Leveler) control turned ON, you can have the TV level out sound that is being heard. This makes for a more consistent sound by reducing the peaks and valleys that occur during program changes or commercial breaks. To turn the AVL ON, follow these steps.

- 1** Press the **MENU** button on the remote control to show the onscreen menu.
- 2** Press the **CURSOR DOWN** button once to highlight **SOUND**.
- 3** Press the **CURSOR RIGHT** button and the menu will shift to the left. **TREBLE** will be highlighted and an adjustment bar will be shown to the right.
- 4** Press the **CURSOR DOWN** button repeatedly until **AVL** is highlighted.
- 5** Press the **CURSOR RIGHT** or **CURSOR LEFT** button to toggle **AVL ON** or **OFF**.
- 6** Press the **STATUS/EXIT** button to remove the menu from the screen.

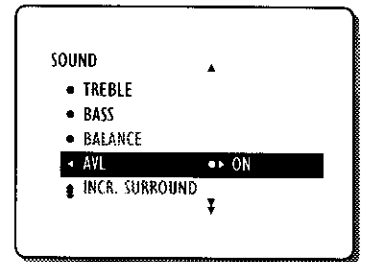
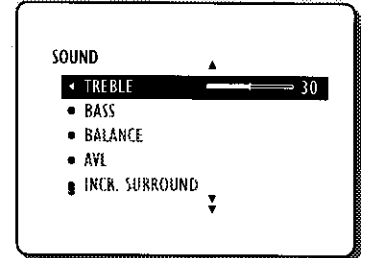
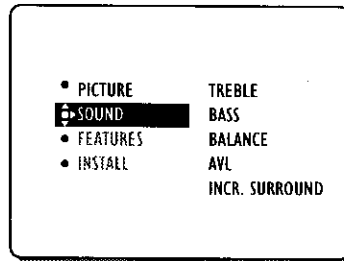

OR

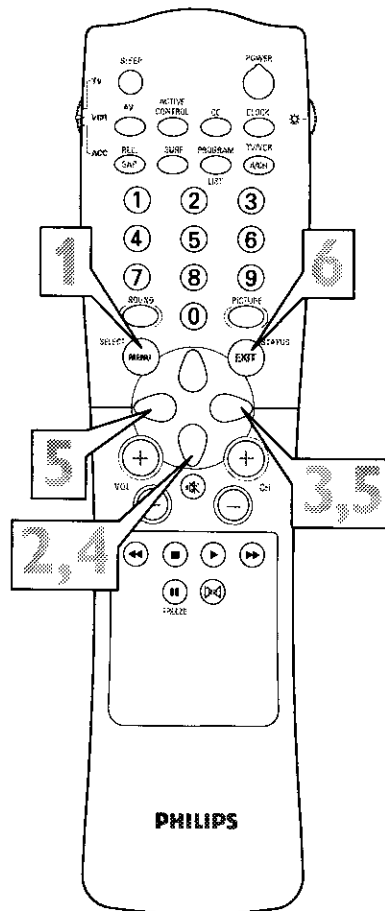
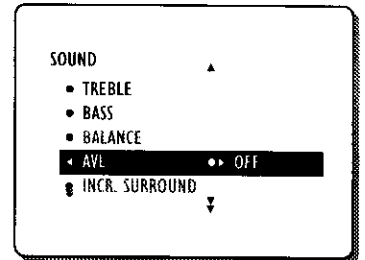

HOW TO USE THE INCREDIBLE SURROUND CONTROL



The Incredible Surround feature adds greater depth and dimension to both monaural (MONO) and stereo TV sound. With the control set to INCR. SURROUND (Incredible Surround), the TV's speakers can add even wider sound separation to normal broadcasts.

- 1 Press the **MENU** button on the remote control to show the onscreen menu.
- 2 Press the **CURSOR DOWN** button once to highlight **SOUND**.
- 3 Press the **CURSOR RIGHT** button and the menu will shift to the left. **TREBLE** will be highlighted and an adjustment bar will be shown to the right.
- 4 Press the **CURSOR DOWN** button repeatedly until **INCR. SURROUND** is highlighted. (Incredible Surround)
- 5 Press the **CURSOR RIGHT** or **CURSOR LEFT** button to toggle the **INCR. SURROUND** control settings.

If signal is **Stereo**: Select **STEREO**, **INCR. SURROUND**, or **DOLBY* VIRTUAL**.

If signal is **MONO**: Select **MONO**, or **SPATIAL**.
- 6 Press the **STATUS/EXIT** button to remove the menu from the screen.
- 7 You can also change the **INCR. SURROUND** onscreen menu control settings by pressing the **VIRTUAL DOLBY** button on the remote control.

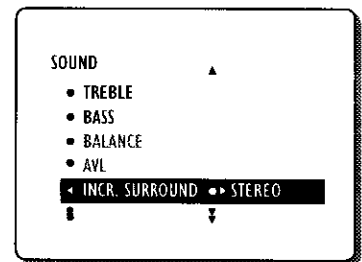
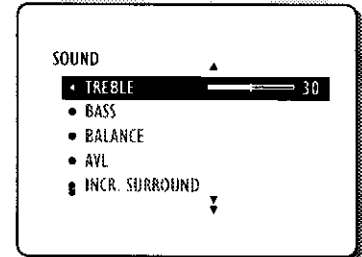
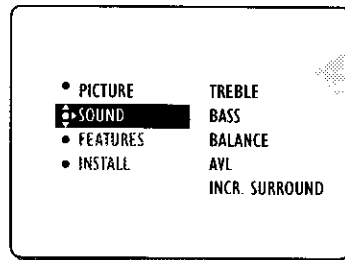

If the signal is in **STEREO**, choose from:

- INCR. SURROUND • STEREO
- INCR. SURROUND • INCR. SURROUND
- INCR. SURROUND • DOLBY VIRTUAL

If the signal is in **MONO**, choose from:

- INCR. SURROUND • MONO
- INCR. SURROUND • SPATIAL

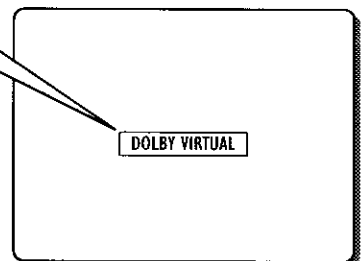
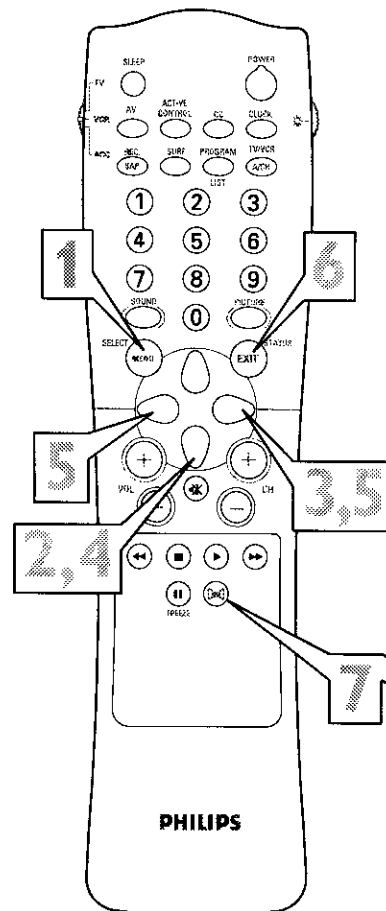

HELPFUL HINT

SPATIAL – widens the sound, simulating a broader, fuller sound.

INCR. SURROUND – widens the sound, simulating a broader, fuller sound.

DOLBY* VIRTUAL (with Virtual Dolby Surround signals) simulates the surround-sound experience from two speakers using Dolby Pro Logic* providing the listener with the sensation of being surrounded by additional speakers.

*Manufactured under license from Dolby Laboratories. "Dolby", "Pro Logic", and the double-D symbol are trademarks of Dolby Laboratories.



HOW TO SET THE STEREO CONTROL

You can receive broadcast stereo TV programs. The TV has both an amplifier and twin speakers through which the stereo sound can be heard.

- 1 Press the **MENU** button on the remote control to show the onscreen menu.
- 2 Press the **CURSOR DOWN** button once to highlight **SOUND**.
- 3 Press the **CURSOR RIGHT** button and the menu will shift to the left. **TREBLE** will be highlighted and an adjustment bar will be shown to the right.
- 4 Press the **CURSOR DOWN** button repeatedly until **STEREO** is highlighted.
- 5 Press the **CURSOR RIGHT** or **CURSOR LEFT** button to select **STEREO** or **MONO**.
- 6 Press the **STATUS/EXIT** button to remove the menu from the screen.

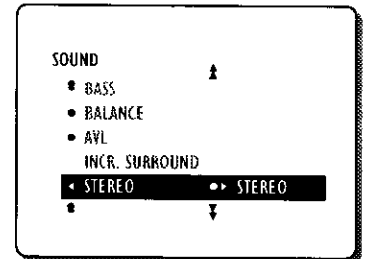
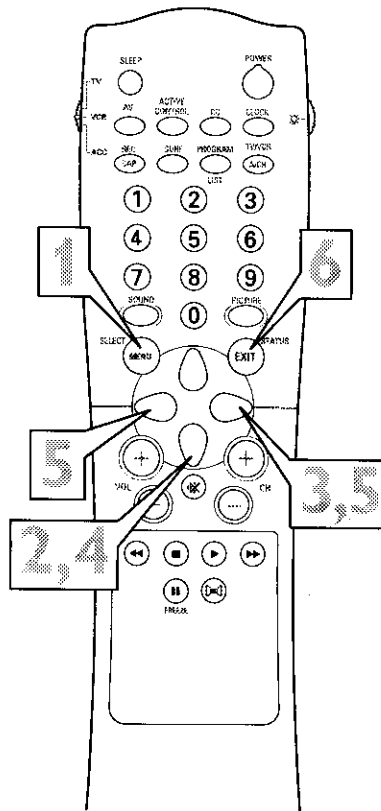
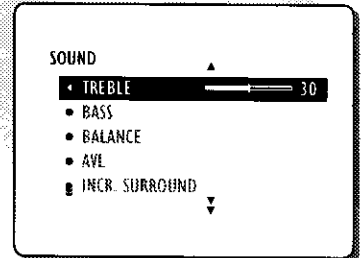
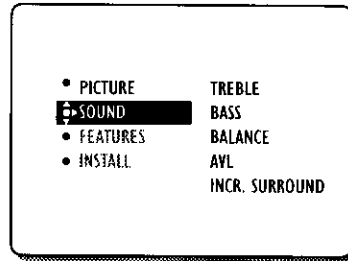

OR

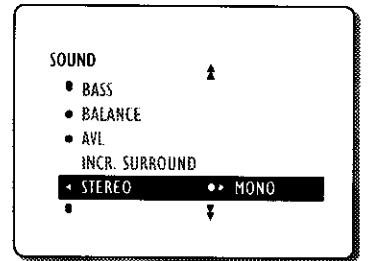

HELPFUL HINT

Remember, if stereo is not present on a selected show and the TV is placed in the **STEREO** mode, the sound coming from the set will remain monaural.

SAP-SECONDARY AUDIO PROGRAM

An SAP is an additional part of the stereo broadcast system. Sent as a third audio channel, an SAP can be heard apart from the current TV program sound. TV stations are free to use SAP for any number of purposes.

If an SAP signal is not present with a selected program, the SAP option cannot be selected. Also, if SAP is selected on a channel (with SAP) and you select another channel, when you return to the original channel, SAP will be OFF. You will have to resselect the SAP feature.

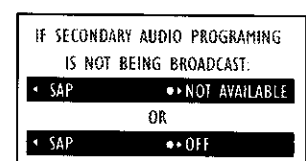
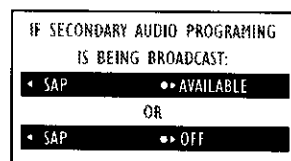
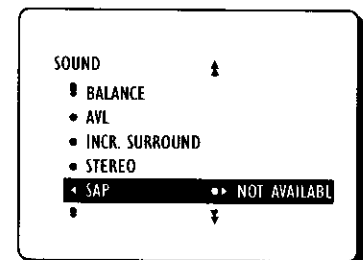
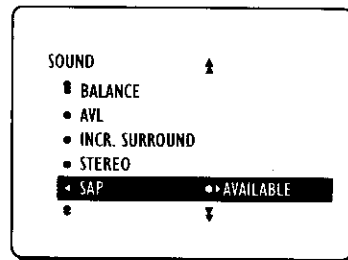

HOW TO USE THE AUDIO OUT CONTROL



If you have connected the TV's AUDIO OUTPUT jacks to the AUDIO INPUT jacks on a stereo receiver (see page 12 for connection instructions), set AUDIO OUT to either VARIABLE or FIXED to determine whether you adjust the volume at the stereo or at the TV. If you select VARIABLE, change the volume at the TV using the TV's remote control. If you select FIXED, adjust the volume at the stereo using the stereo's controls. To select FIXED or VARIABLE, follow these steps.

- 1 Press the MENU button on the remote control to show the onscreen menu.
- 2 Press the CURSOR DOWN button once to highlight SOUND.
- 3 Press the CURSOR RIGHT button and the menu will shift to the left. TREBLE will be highlighted and an adjustment bar will be shown to the right.
- 4 Press the CURSOR DOWN button repeatedly until AUDIO OUT is highlighted.
- 5 Press the CURSOR RIGHT or CURSOR LEFT button to select FIXED or VARIABLE.
- 6 Press the STATUS/EXIT button to remove the menu from the screen.

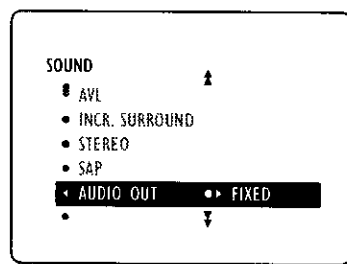
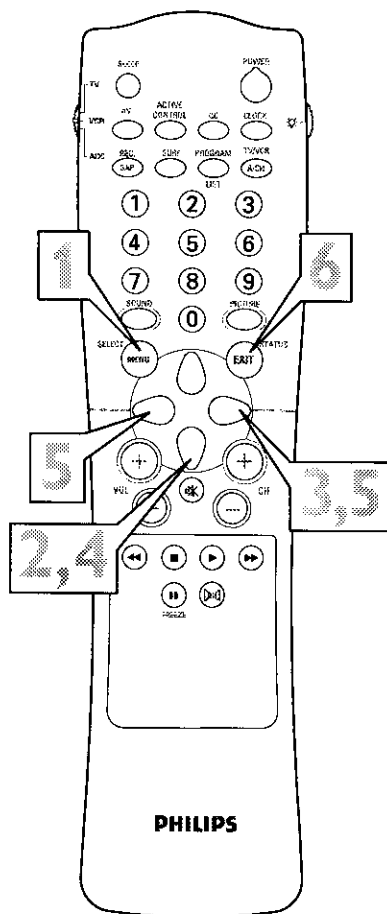
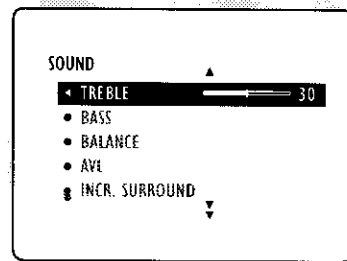
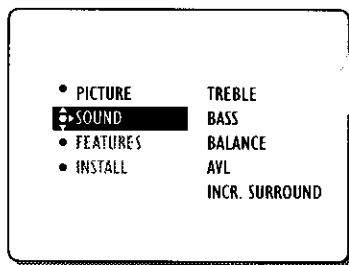

OR

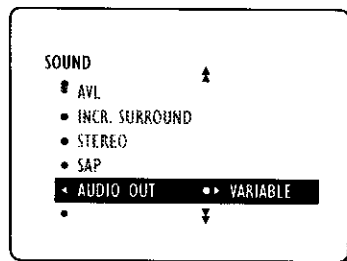

HELPFUL HINT

FIXED – If FIXED is selected, the sound coming from the TV and being heard through an external audio system is not adjustable with the television's volume controls. The volume would have to be adjusted at the audio system.

VARIABLE – If VARIABLE is selected, the sound coming from the TV and being heard through an external audio system can be adjusted at the TV using the Volume + or – buttons on the television or remote control.

Remember, the connection instructions for an external audio system is located on page 13.



HOW TO TURN THE TV SPEAKERS ON OR OFF

Using the TV's Audio (Monitor) Output jacks and TV Speaker ON/OFF control an external audio system can be used to hear the sound coming from the TV. The Speaker Control will allow you to turn the television's speakers off so the TV sound would only be heard through the audio system. Please refer to page 13 for the proper connections needed to hookup an external audio system.

- 1 Press the **MENU** button on the remote control to show the onscreen menu.
- 2 Press the **CURSOR DOWN** button once to highlight **SOUND**.
- 3 Press the **CURSOR RIGHT** button and the menu will shift to the left. **TREBLE** will be highlighted and an adjustment bar will be shown to the right.
- 4 Press the **CURSOR DOWN** button repeatedly until **SPEAKERS** is highlighted.
- 5 Press the **CURSOR RIGHT** or **CURSOR LEFT** button to turn the television's speakers **ON** or **OFF**.
- 6 Press the **STATUS/EXIT** button to remove the menu from the screen.

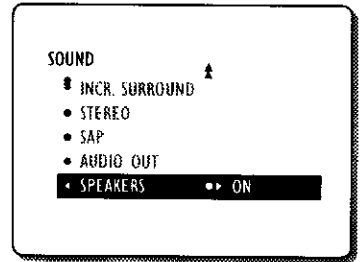
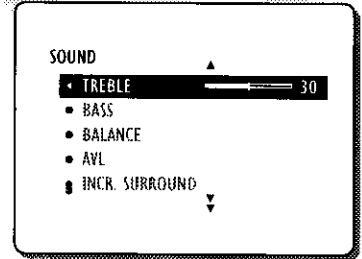
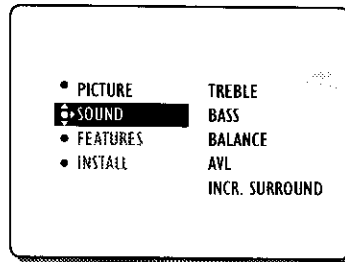

OR

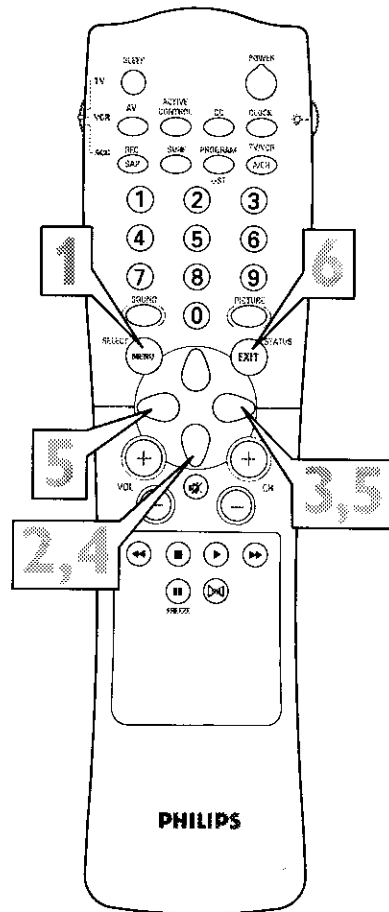
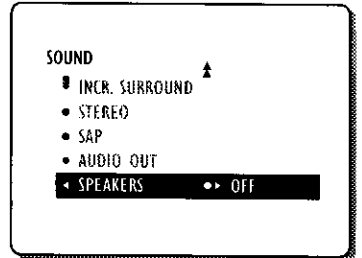

HELPFUL HINT

Be sure to first connect an external audio system to the television's Monitor Output (audio) jacks.

Refer to page 13 for the proper hookup procedure. If the **SPEAKERS** Control is turned **OFF** and no external audio system is connected, there will be no sound heard at the TV.

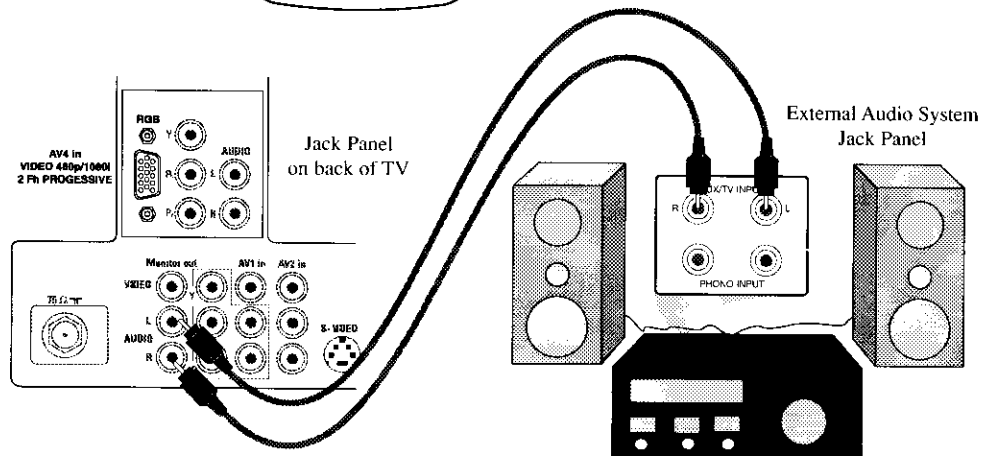

SETTING THE TV CLOCK USING THE TIMER CONTROL



Your television comes with an on-screen clock. During normal operation, the clock appears on the screen when the STATUS/EXIT button is pressed or if the TIMER DISPLAY control is turned ON.

- 1 Press the **MENU** button on the remote control to show the onscreen menu.
- 2 Press the **CURSOR DOWN** button twice to highlight FEATURES.
- 3 Press the **CURSOR RIGHT** button and the menu will shift to the left. **TIMER** will be highlighted.
- 4 With **TIMER** selected, press the **CURSOR RIGHT** button again to shift the display left and highlight the **TIME** control.
- 5 Press the **CURSOR RIGHT** button again to highlight the time indicator area.
- 6 Press the **CURSOR LEFT** or **CURSOR RIGHT** button to select the position or digit you wish to enter.
- 7 Press the **CURSOR UP** or **CURSOR DOWN** button to select the digits for the time. Or press the **NUMBERED** buttons to enter the correct time.
- 8 Press the **CURSOR RIGHT** button to move to the AM or PM position.
- 9 Press the **CURSOR UP** or **CURSOR DOWN** button to set AM or PM.
- 10 Press the **STATUS/EXIT** button to remove the menu from the screen.

NOTE: The **TIMER** Controls can also be accessed by pressing the **CLOCK** button on the remote control. See lower diagram on this page.

HELPFUL HINT

Remember, be sure to press 0 first and then the hour number for single-digit entries.

The Clock also can be set automatically using the AutoChron™ feature found on page 4 of the *Quick Use and Installation Guide* that came with your television.

The TV's clock settings may be lost when the TV is unplugged (or when AC power to the set is interrupted).

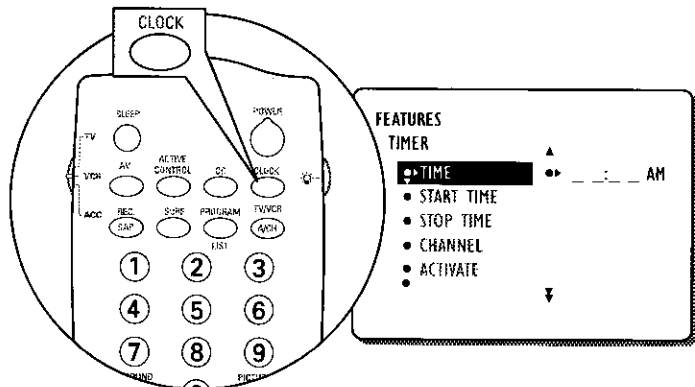
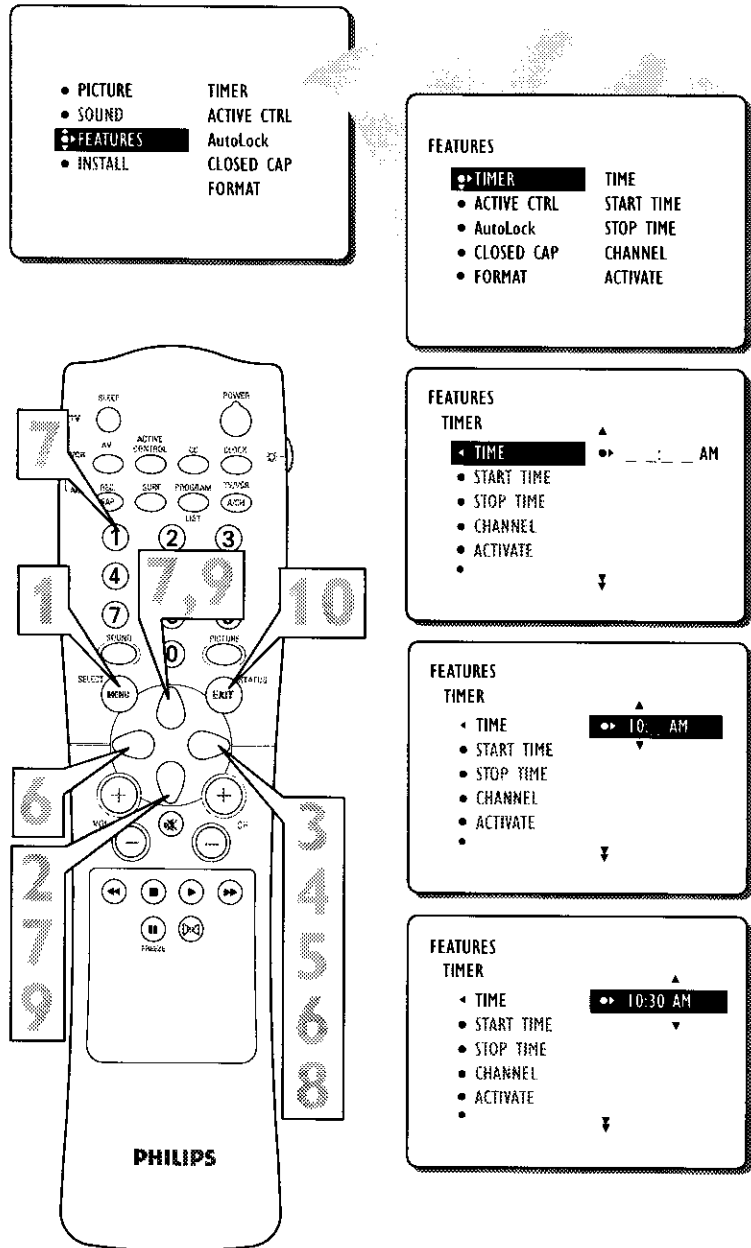



SETTING THE TV TO TURN ITSELF ON USING THE START TIME CONTROL

Just as you would an alarm clock, you can set the TV to turn itself ON once or at the same time every day. Follow these steps to set the Start Time.

- 1 Press the **MENU** button on the remote control to show the onscreen menu.
- 2 Press the **CURSOR DOWN** button twice to highlight FEATURES.
- 3 Press the **CURSOR RIGHT** button and the menu will shift to the left. **TIMER** will be highlighted.
- 4 With **TIMER** selected, press the **CURSOR RIGHT** button again to shift the display left.
- 5 Press the **CURSOR DOWN** button to highlight the **START TIME** control.
- 6 Press the **CURSOR RIGHT** button again to highlight the time indicator area.
- 7 Press the **CURSOR RIGHT** or **CURSOR LEFT** button to move among the positions where the time is input.
- 8 Press the **CURSOR UP** or **CURSOR DOWN** button to select the digits for the time. Or press the **NUMBERED** buttons to enter the time you want the television to turn itself on.
- 9 Press the **CURSOR RIGHT** button to move to the **AM** or **PM** position.
- 10 Press the **CURSOR UP** or **DOWN** button to set **AM** or **PM**.
- 11 Press the **STATUS/EXIT** button to remove the menu from the screen.

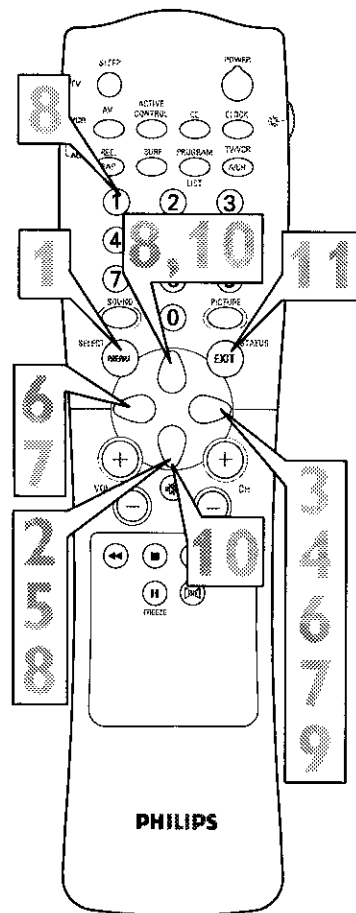
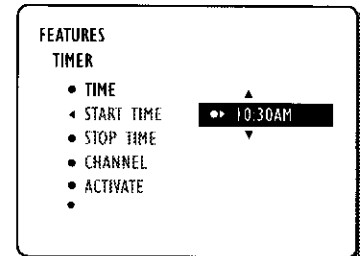
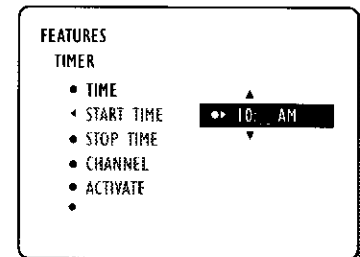
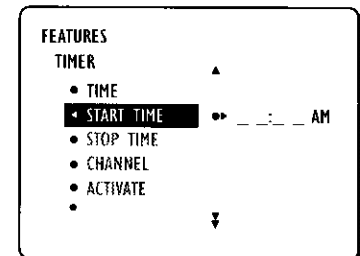
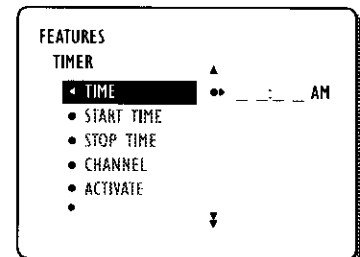
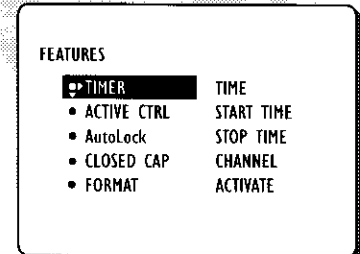
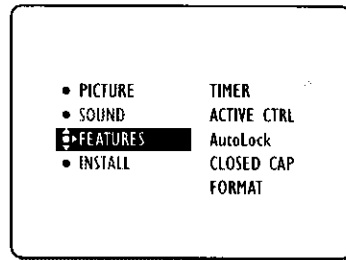

HELPFUL HINT

Remember, be sure to press 0 first and then the hour number for single-digit entries.

The **ACTIVATE** Control must be set to **ONCE** or **DAILY** for the television to shut itself off at the specified time. See page 27 for more details about the **ACTIVATE** Control.

SETTING THE TV TO TURN ITSELF OFF USING THE STOP TIME CONTROL



The following steps will guide you in setting the TV to turn itself OFF at a specific time.

- 1 Press the **MENU** button on the remote control to show the onscreen menu.
- 2 Press the **CURSOR DOWN** button twice to highlight **FEATURES**.
- 3 Press the **CURSOR RIGHT** button and the menu will shift to the left. **TIMER** will be highlighted.
- 4 With **TIMER** selected, press the **CURSOR RIGHT** button again to shift the display left.
- 5 Press the **CURSOR DOWN** button to highlight the **STOP TIME** control.
- 6 Press the **CURSOR RIGHT** button again to highlight the time indicator area.
- 7 Press the **CURSOR RIGHT** or **CURSOR LEFT** button to move among the positions where the time is input.
- 8 Press the **CURSOR UP** or **CURSOR DOWN** button to select the digits for the time. Or press the **NUMBERED** buttons to enter the time you want the television to turn itself off.
- 9 Press the **CURSOR RIGHT** button to move to the **AM** or **PM** position.
- 10 Press the **CURSOR UP** or **DOWN** button to set **AM** or **PM**.
- 11 Press the **STATUS/EXIT** button to remove the menu from the screen.

NOTE: The **ACTIVATE Control** (page 27) must be set to **ONCE** or **DAILY** for the **STOP TIME Control** to take effect.

HELPFUL HINT

Remember, be sure to press **0** first and then the hour number for single-digit entries.

The **ACTIVATE Control** must be set to **ONCE** or **DAILY** for the television to shut itself off at the specified time. See page 27 for more details about the **ACTIVATE Control**.

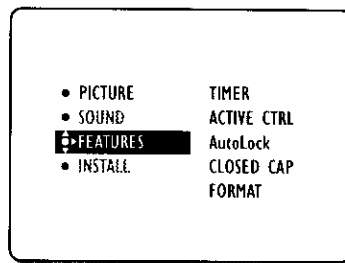

- TIMER
- ACTIVE CTRL
- AutoLock
- CLOSED CAP
- FORMAT

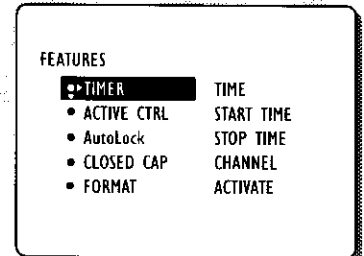

- TIME
- START TIME
- STOP TIME
- CHANNEL
- ACTIVATE

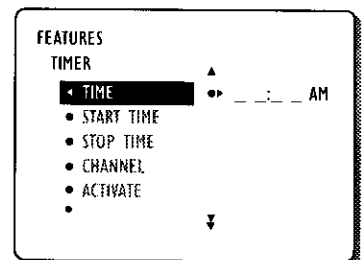
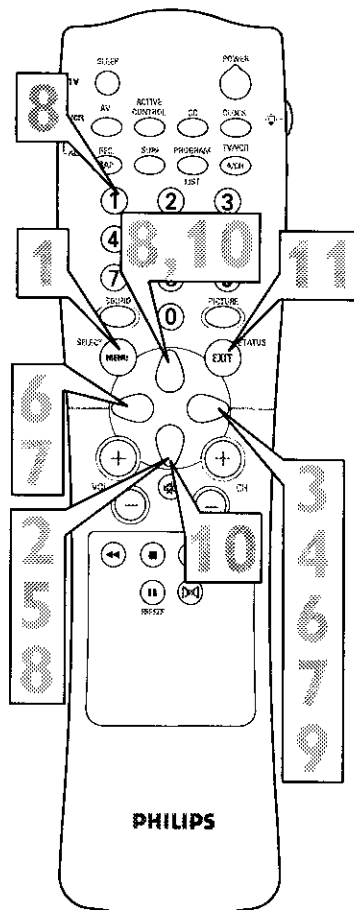

▲

▶ _ _ : _ _ AM

▼

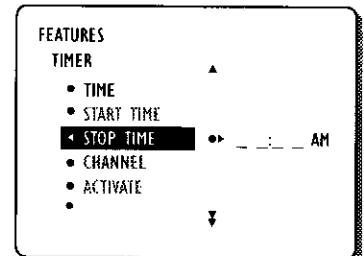

▲

▶ 11 : _ _ AM

▼

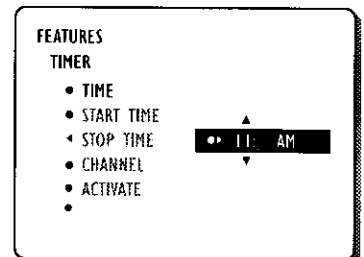

▲

▶ 11 : 00 AM

▼

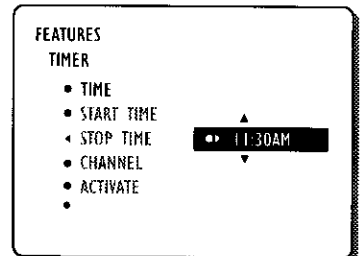

▲

▶ 11 : 30AM

▼



SETTING THE TV TO STARTUP ON A SPECIFIC CHANNEL USING THE CHANNEL CONTROL

You can select a specific channel that the television will tune to when the timer turns the set ON. Follow these steps to select the channel.

- 1** Press the **MENU** button on the remote control to show the onscreen menu.
 - 2** Press the **CURSOR DOWN** button twice to highlight **FEATURES**.
 - 3** Press the **CURSOR RIGHT** button and the menu will shift to the left. **TIMER** will be highlighted.
 - 4** With **TIMER** selected, press the **CURSOR RIGHT** button again to shift the display left.
 - 5** Press the **CURSOR DOWN** button to highlight the **CHANNEL** Control.
 - 6** Press the **NUMBERED** buttons to enter the desired start-up channel. Or, press the **CURSOR RIGHT** or **CURSOR LEFT** button repeatedly to enter the start-up channel you want.
- NOTE:** The **ACTIVATE** Control (page 27) must be set to **ONCE** or **DAILY** for this Channel Control to take effect.
- 7** Press the **STATUS/EXIT** button to remove the menu from the screen.

HELPFUL HINT

The **ACTIVATE** Control must be set to **ONCE** or **DAILY** for the television to shut itself off at the specified time. See page 27 for more details about the **ACTIVATE** Control.

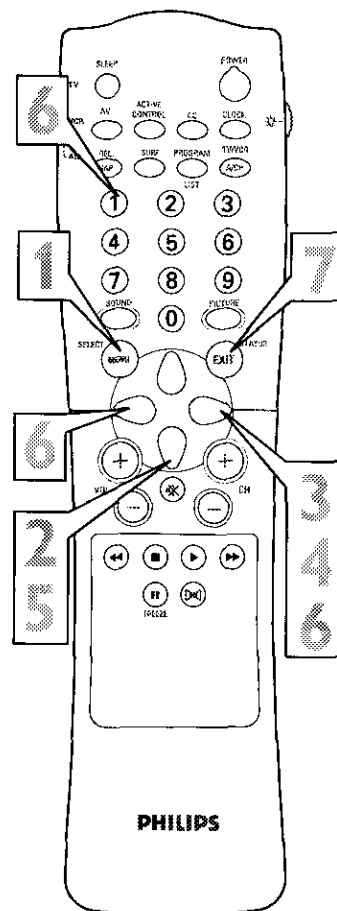
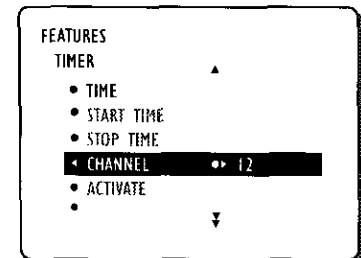
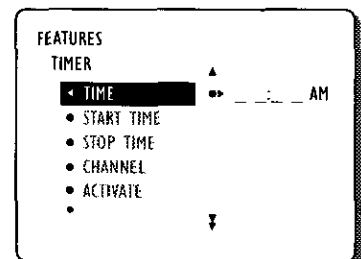
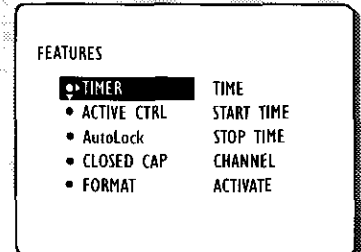
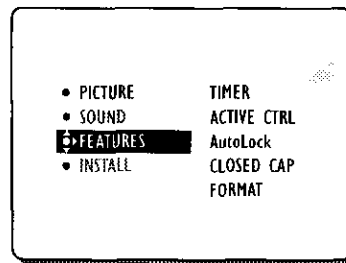

HOW TO ACTIVATE THE TIMER CONTROL USING THE ACTIVATE CONTROL



After you have set the Time, Start Time, Stop Time, and Start Channel, the timer must be set to come on ONCE or DAILY, or turned OFF through the ACTIVATE Control.

- 1 Press the **MENU** button on the remote control to show the onscreen menu.
- 2 Press the **CURSOR DOWN** button twice to highlight FEATURES.
- 3 Press the **CURSOR RIGHT** button and the menu will shift to the left. **TIMER** will be highlighted.
- 4 With **TIMER** selected, press the **CURSOR RIGHT** button again to shift the display left.
- 5 Press the **CURSOR DOWN** button to highlight the **ACTIVATE** Control.
- 6 Press the **CURSOR RIGHT** or **CURSOR LEFT** button repeatedly to select **ONCE**, **DAILY** or **OFF**.
- 7 Press the **STATUS/EXIT** button to remove the menu from the screen.

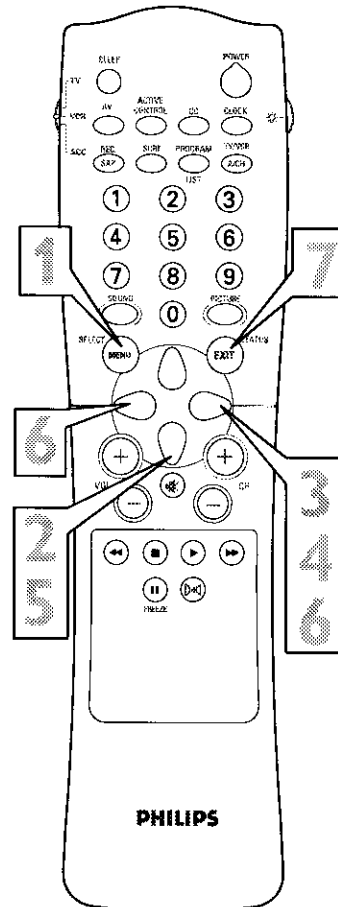
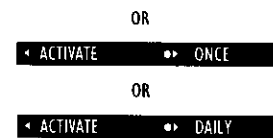
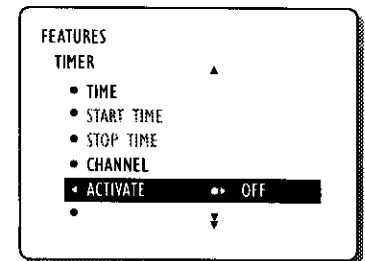
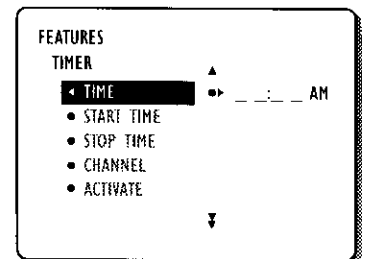
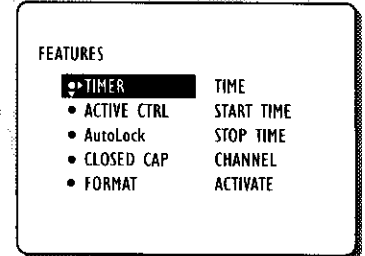
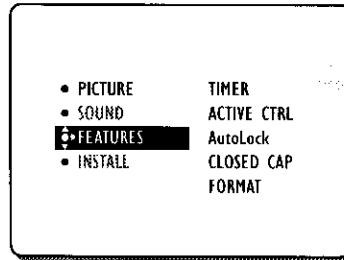

✓ CHECK IT OUT

With the **ACTIVATE** Control set to **ONCE**, the **START TIME**, **STOP TIME**, and **START CHANNEL** Controls will only be activated one time.

With the **ACTIVATE** Control set to **DAILY**, the **START TIME**, **STOP TIME**, and **START CHANNEL** Controls will be activated every day of the week until it is turned **OFF** or set to **ONCE**.

HELPFUL HINT

Remember, before setting the **TIMER** controls, the TV's clock must be set to the correct time manually (see page 23) or by using the **AutoChron™** feature described on page 4 of the *Quick Use and Installation Guide*.



HOW TO VIEW THE TIME USING THE DISPLAY CONTROL

After the TV's clock has been set, you can use your TV as a clock. The **TIMER DISPLAY** control allows you to permanently display the time in the upper right corner of the screen.

- 1 Press the **MENU** button on the remote control to show the onscreen menu.
- 2 Press the **CURSOR DOWN** button twice to highlight **FEATURES**.
- 3 Press the **CURSOR RIGHT** button and the menu will shift to the left. **TIMER** will be highlighted.
- 4 With **TIMER** selected, press the **CURSOR RIGHT** button again to shift the display left.
- 5 Press the **CURSOR DOWN** button to highlight the **DISPLAY** Control.
- 6 Press the **CURSOR RIGHT** or **CURSOR LEFT** button repeatedly to select **ON** or **OFF**.
- 7 Press the **STATUS/EXIT** button to remove the menu from the screen.

CHECK IT OUT

If the **TIME** has been set and the **DISPLAY** Control set to **ON**, the current time will appear in the upper right corner of the TV screen while the TV is powered on.

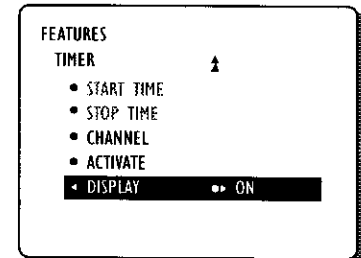
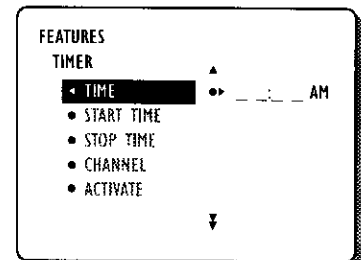
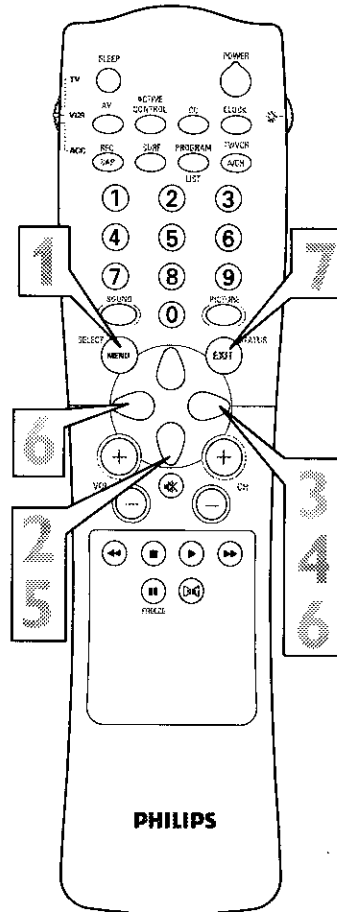
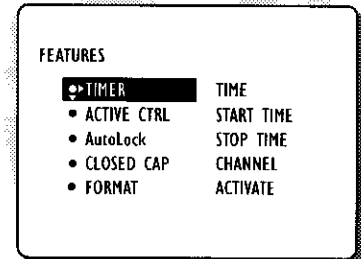
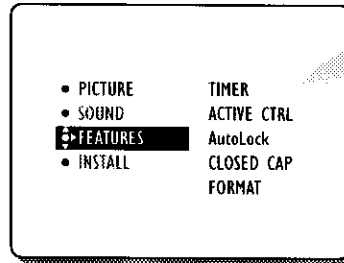

OR

◀ DISPLAY ▶ OFF

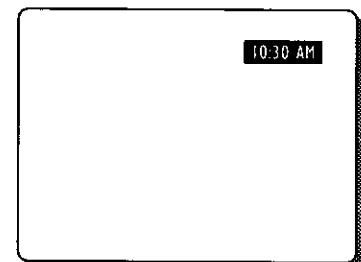

HOW TO USE THE ACTIVE CONTROL



The Active Control monitors and adjusts incoming video signals to help provide the best picture quality.

When you choose to turn the Active Control ON, the picture sharpness and noise reduction are controlled automatically. Active Control adjusts these picture settings continuously and automatically.

NOTE: Active Control is not available for signals connected to the AV4 inputs.

- 1 Press the **MENU** button on the remote control to show the on-screen menu.
 - 2 Press the **CURSOR DOWN** button twice to highlight **FEATURES**.
 - 3 Press the **CURSOR RIGHT** button and the menu will shift to the left.
 - 4 Press the **CURSOR DOWN** button repeatedly until the **ACTIVE CTRL** (control) is highlighted.
 - 5 Press the **CURSOR RIGHT** or **CURSOR LEFT** button repeatedly to toggle the **ACTIVE CONTROL** ON or OFF.
 - 6 Press the **STATUS/EXIT** button to remove the menu from the screen.
-
- 7 You can also press the **ACTIVE CONTROL** button on the remote control to toggle the **ACTIVE CONTROL** ON or OFF.

CHECK IT OUT

Toggle the **ACTIVE CONTROL ON** with the remote control and a screen display will appear showing the Active Control in work. You will see the sharpness and noise reduction settings changing to provide the best possible picture quality.

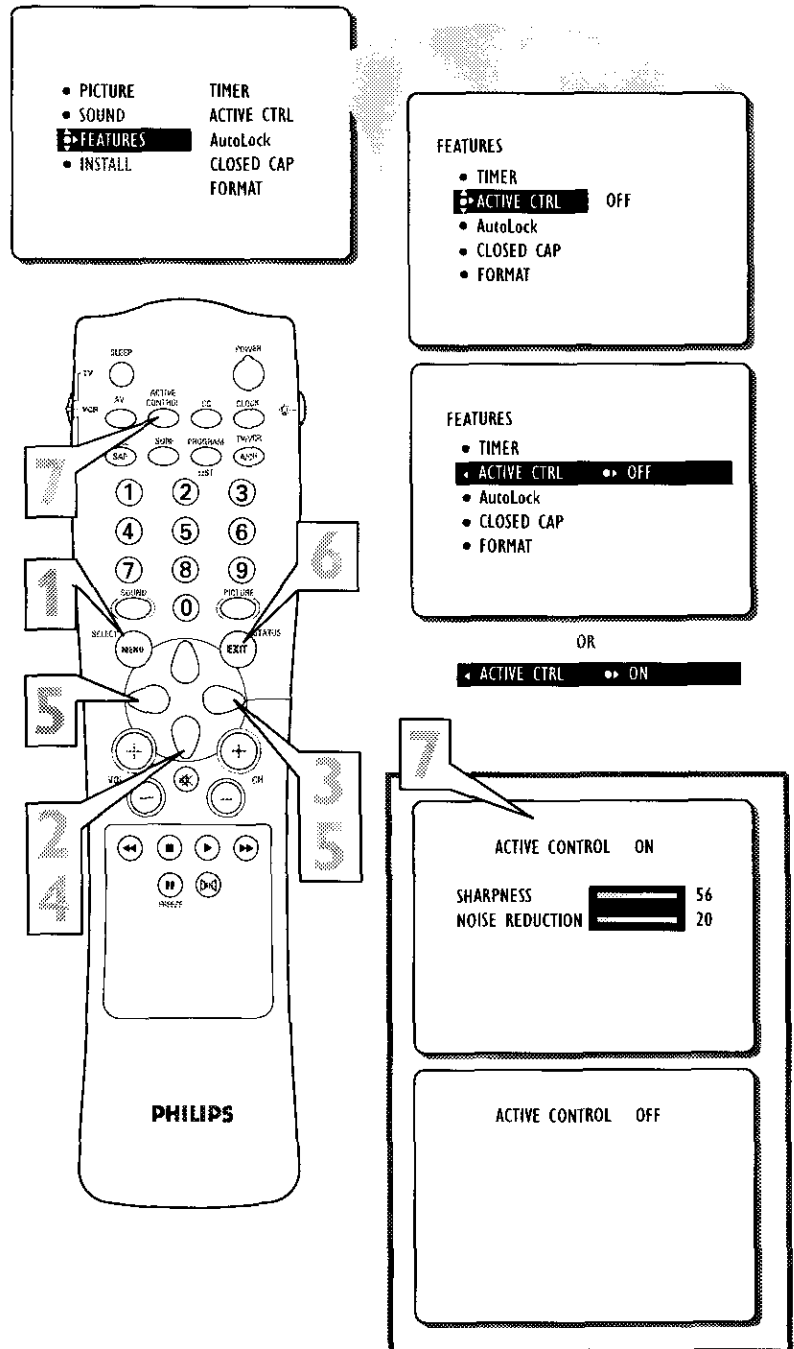



UNDERSTANDING THE AUTOLOCK™ FEATURE

The AutoLock™ feature receives and processes data sent by broadcasters or other program providers that contain program content advisories. When programmed by the viewer, a TV with AutoLock™ can respond to the content advisories and block program content that may be found objectionable (such as offensive language, violence, sexual situations, etc.). This is a great feature to censor the type of programming children may watch.

In the AutoLock™ section, you'll learn how to block channels and programming that is not rated, is unrated, or has no rating. You will also find out how to turn these blocking features ON or OFF. Following are brief explanations of some terms and ratings related to the AutoLock™ feature.

AutoLock™ offers various Blocking Options from which to choose:

BLOCKING: The BLOCKING control is what can be thought of as the "master switch" for AutoLock™. This control affects the settings you have chosen for blocking programs according to movie ratings or TV ratings, or for blocking programs that have no rating or are unrated. When the BLOCKING control is OFF, the blocking or censoring of programs is disabled. When the BLOCKING control is ON, blocking will occur according to the settings you have chosen.

NO RATING: ALL programming with no content advisory data can be blocked if NO RATING is set to ON.

Programming that has No Rating is not encoded with any rating information from the MPAA or the Parental Guidelines. Any programming could fall into this category.

You also can block individual channels or block programming based on ratings of the MPAA and TV broadcasters. (See a description of the ratings on this page.)

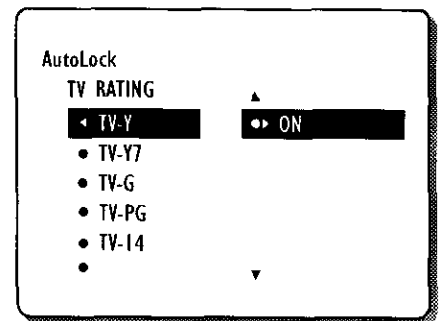
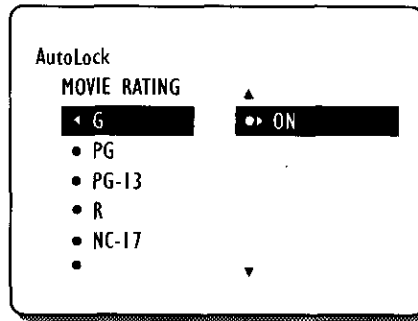

MOVIE RATINGS (MOTION PICTURE ASSOCIATION OF AMERICA)

G: General Audience - All ages admitted. Most parents would find this programming suitable for all ages. This type of programming contains little or no violence, no strong language, and little or no sexual dialogue or sexual situations.

PG: Parental Guidance Suggested - This programming contains material that parents may find unsuitable for younger children. It may contain one or more of the following: Moderate violence, some sexual situations, infrequent coarse language, or some suggestive dialogue.

PG-13: Parents Strongly Cautioned - This programming contains material that parents may find unsuitable for children under the age of 13. It contains one or more of the following: violence, sexual situations, coarse language, or suggestive dialogue.

R: Restricted - This programming is specifically designed for adults. Anyone under the age of 17 should view this programming only with an accompanying parent or adult guardian. It contains one or more of the following: intense violence; intense sexual situations; strong, coarse language; or intensely suggestive dialogue.

NC-17: No one under the age of 17 will be admitted. - This type of programming should be viewed by adults only. It contains graphic violence; explicit sex; or crude, indecent language.

X: Adults Only - This type of programming contains one or more of the following: very graphic violence, very graphic and explicit or indecent sexual acts, very coarse and intensely suggestive language.

TV PARENTAL GUIDELINES (TV BROADCASTERS)

TV-Y: (All children -- This program is designed to be appropriate for all children.) Designed for a very young audience, including children ages 2-6. This type of programming is not expected to frighten younger children.

TV-Y7: (Directed to Older Children -- This program is designed for children ages 7 and above.) It may be more appropriate for children who have acquired the development skills needed to distinguish between make-believe and reality. This programming may include mild fantasy and comic violence (FV).

TV-G: (General Audience -- Most parents would find this program suitable for all ages.) This type of programming contains little or no violence, no strong language, and little or no sexual dialogue or sexual situations.

TV-PG: (Parental Guidance Suggested -- This program contains material that parents may find unsuitable for younger children.) This type of programming contains one or more of the following: Moderate violence (V), some sexual situations (S), infrequent coarse language (L), or some suggestive dialogue (D).

TV-14: (Parents Strongly Cautioned -- This program contains some material that many parents would find unsuitable for children under 14 years of age.) This type of programming contains one or more of the following: intense violence (V); intense sexual situations (S); strong, coarse language (L); or intensely suggestive dialogue (D).

TV-MA: (Mature Audience Only -- This program is specifically designed to be viewed by adults and therefore may be unsuitable for children under 17.) This type of programming contains one or more of the following: graphic violence (V); explicit sexual situations (S); or crude, indecent language (L).

SETTING UP AN AUTOLOCK™ ACCESS CODE



AutoLock™ allows parents to block out or “censor” any channels they think children should not watch. A channel blocked by the AutoLock™ control cannot be viewed until a correct access code is used to unlock the channel for viewing. First, let’s set your AutoLock access code.

- 1** Press the **MENU** button on the remote control to show the onscreen menu.
- 2** Press the **CURSOR DOWN** button twice to highlight **FEATURES**.
- 3** Press the **CURSOR RIGHT** button and the menu will shift to the left.
- 4** Press the **CURSOR DOWN** button once to highlight the AutoLock control.
- 5** Press the **CURSOR RIGHT** button to highlight **ACCESS CODE**.
- 6** Press **0,7,1,1** on the remote control. **INCORRECT** will appear on the screen.
- 7** Press **0,7,1,1** on the remote control again. **ENTER NEW CODE** will appear on the screen.
- 8** Enter a new four-digit code using the number buttons. **CONFIRM CODE** will appear on the screen.
- 9** Enter your new four-digit code again. **CORRECT** will flash on the screen briefly and the highlight bar goes back to AutoLock.
- 10** Press the **STATUS/EXIT** button to remove the menu from the screen.

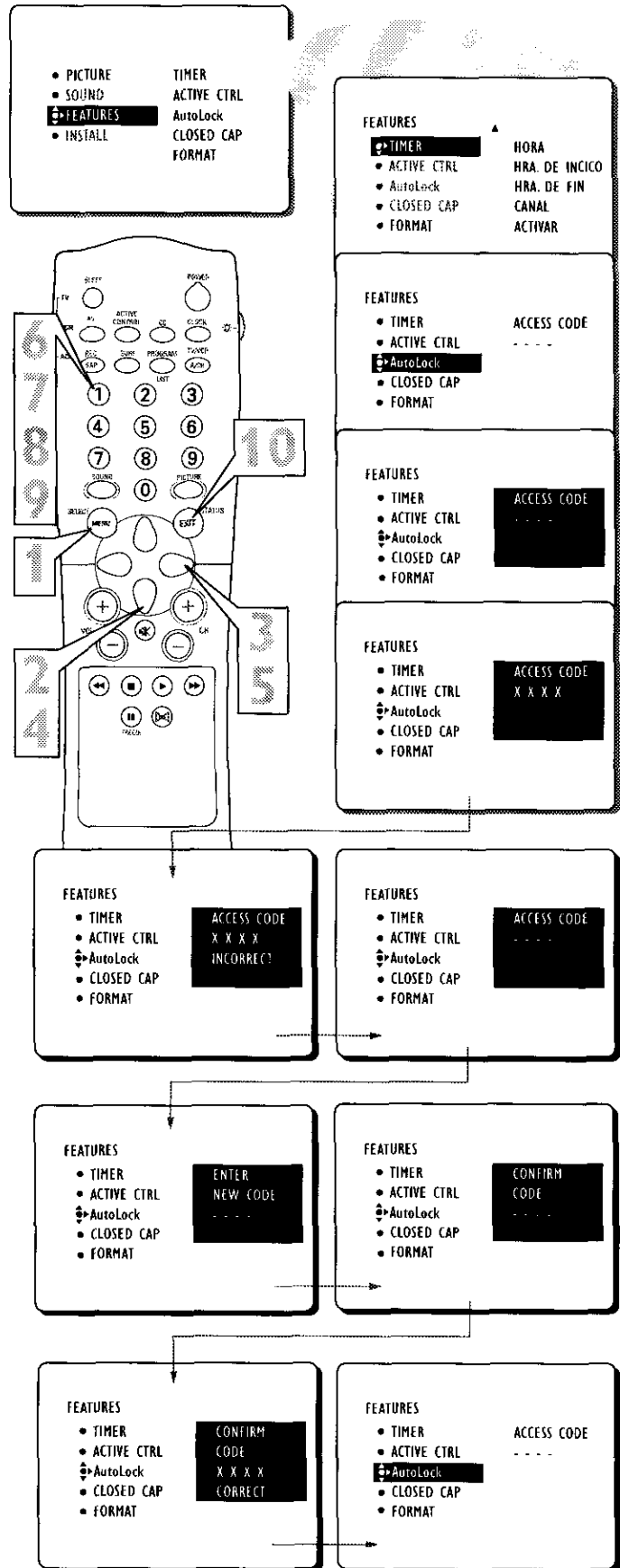

HELPFUL HINT

Remember that 0711 is the default AutoLock™ code. If your access code has been changed by someone other than you (a child, for example) or you have forgotten the code, you can always get in by inputting the default code.

NOTE TO PARENTS: It isn't possible for your child to unblock a channel without knowing your access code or changing it to a new one. If your code has been changed without your knowledge, then you will become aware that blocked channels may have been viewed.



HOW TO BLOCK CHANNEL USING AUTOLOCK™

After your personal access code has been set (see the previous page), you are ready to select the channels or inputs you want to block out or censor.

- 1 Press the **MENU** button on the remote control to show the onscreen menu.
- 2 Press the **CURSOR DOWN** button twice to highlight **FEATURES**.
- 3 Press the **CURSOR RIGHT** button and the menu will shift to the left.
- 4 Press the **CURSOR DOWN** button once to highlight the **AutoLock™** control.
- 5 Press the **CURSOR RIGHT** button again to highlight **ACCESS CODE**.
- 6 Enter your four-digit **ACCESS CODE**. **CORRECT** will flash very briefly and the menu will move to the left with **BLOCK CHANNEL** highlighted.
- 7 Press the **CURSOR RIGHT** button to highlight the TV's available channels.
- 8 Press the **CURSOR UP** or **CURSOR DOWN** button to highlight the channel you want to block.
- 9 Press the **CURSOR RIGHT** button to block the channel. A padlock image appears to the right of the channel number.

Repeat steps 7 and 8 for any channels you want to block from viewing.

- 10 Press the **STATUS/EXIT** button to remove the menu from the screen.

HELPFUL HINT

Remember that 0711 is the default AutoLock™ code. If your access code has been changed by someone other than you (a child, for example) or you have forgotten the code, you can always get in by inputting the default code.

NOTE: You also can block out the use of the A/V external inputs on the rear of the TV. This stops the viewing of VCR, DVD, and other sources that can be shown through the A/V input jacks. Select AV1, CVI, AV2, SIDE (AV3), or AV4; and then select **BLOCK**.

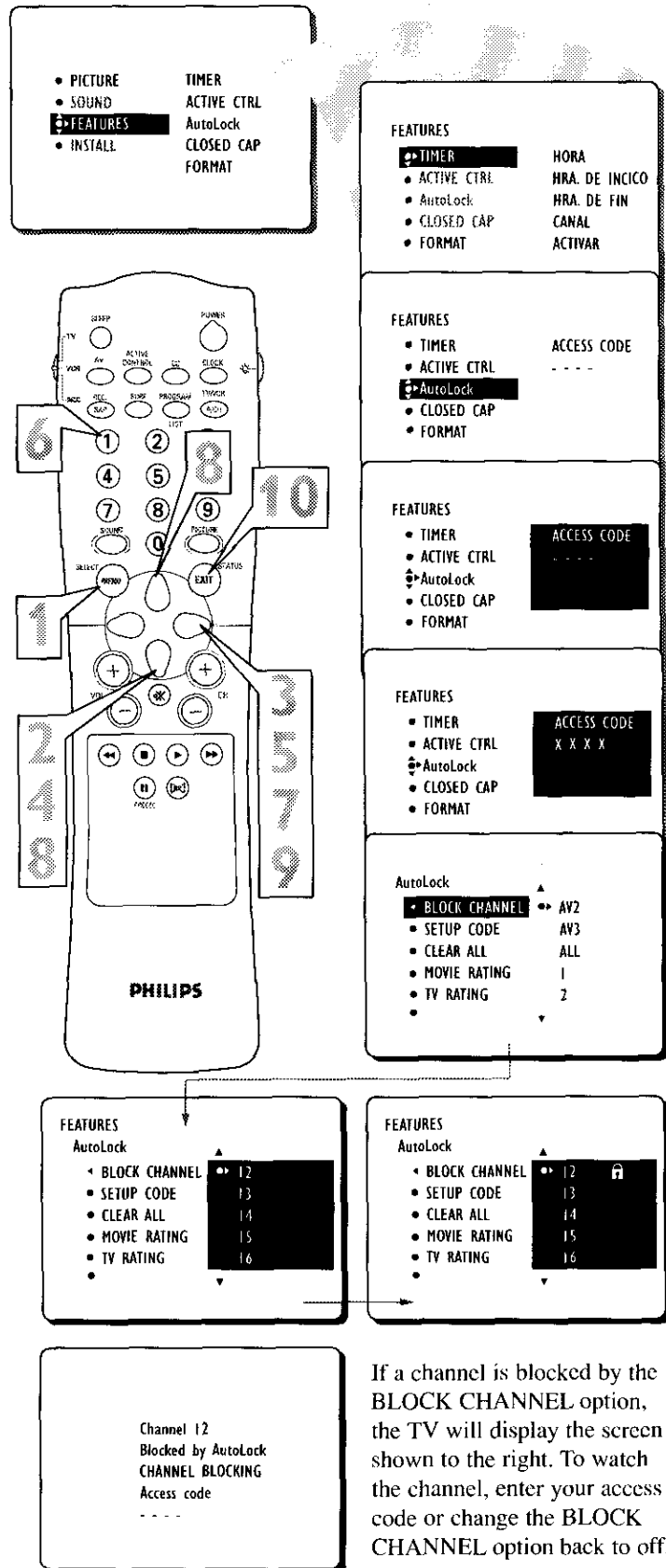

If a channel is blocked by the **BLOCK CHANNEL** option, the TV will display the screen shown to the right. To watch the channel, enter your access code or change the **BLOCK CHANNEL** option back to off.

HOW TO CLEAR ALL BLOCKED CHANNELS USING AUTOLOCK™



Various onscreen messages will appear when someone tries to view blocked programming. The message is determined by the current programming is blocked. You may view the blocked programming and turn OFF the AutoLock™ feature by using the Clear All control or by entering your access code.

- 1 Press the **MENU** button on the remote control to show the onscreen menu.
- 2 Press the **CURSOR DOWN** button twice to highlight **FEATURES**.
- 3 Press the **CURSOR RIGHT** button and the menu will shift to the left.
- 4 Press the **CURSOR DOWN** button once to highlight the **AutoLock™** control.
- 5 Press the **CURSOR RIGHT** button again to highlight **ACCESS CODE**.
- 6 Enter your four-digit **ACCESS CODE** and the menu will move to the left with **BLOCK CHANNEL** high-lighted.
- 7 Press the **CURSOR DOWN** button twice to highlight **CLEAR ALL**.
- 8 Press the **CURSOR RIGHT** button twice. The **CLEAR ALL** option will display the word **CLEARED**. All blocked channels and programming are now viewable.
- 9 Press the **STATUS/EXIT** button to remove the menu from the screen.

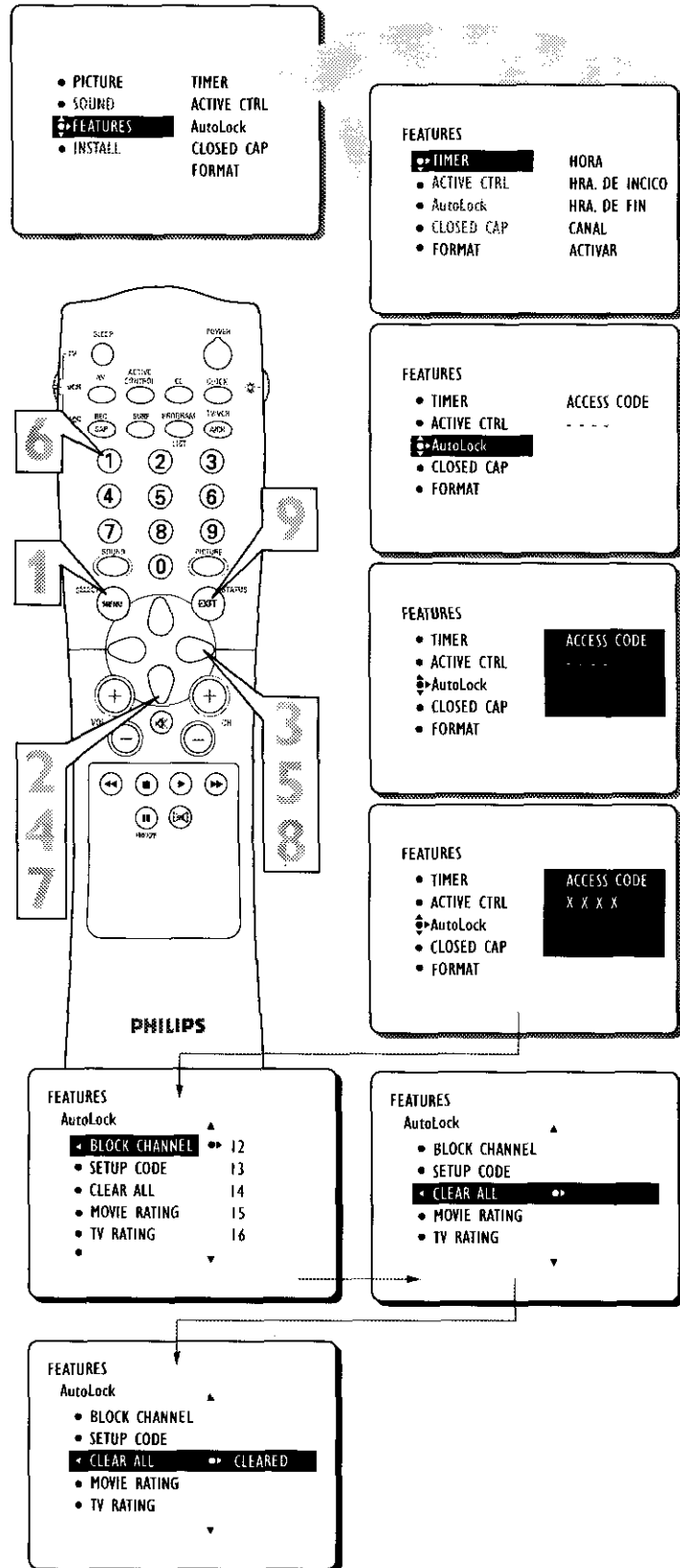

HELPFUL HINT

If you tune to a specific channel that has been blocked by **BLOCK CHANNEL** or any of the AutoLock™ **RATING** options, simply enter your four-digit access code to view the channel.

NOTE: this will unblock ALL channels until the TV is shut OFF. When powered back ON, all previously blocked channels will be blocked again.



HOW TO BLOCK PROGRAMMING BASED ON MOVIE RATINGS

After your personal access code has been set, you can select specific movie ratings that you want to censor.

- 1 Press the **MENU** button on the remote control to show the onscreen menu.
- 2 Press the **CURSOR DOWN** button twice to highlight **FEATURES**.
- 3 Press the **CURSOR RIGHT** button and the menu will shift to the left.
- 4 Press the **CURSOR DOWN** button once to highlight the **AutoLock™** control.
- 5 Press the **CURSOR RIGHT** button again to highlight **ACCESS CODE**.
- 6 Enter your four-digit **ACCESS CODE**. **CORRECT** will flash very briefly and the menu will move to the left with **BLOCK CHANNEL** highlighted.
- 7 Press the **CURSOR DOWN** button repeatedly until **MOVIE RATING** is highlighted.
- 8 Press the **CURSOR RIGHT** button and the Rating menu shifts to the left with **G** highlighted.
- 9 Press the **CURSOR UP** or **CURSOR DOWN** button to highlight each rating you want.
- 10 Press the **CURSOR RIGHT** button to turn the rating **ON** or **OFF**. Turning the rating **ON** will block programs with that rating from being seen.
- 11 Press the **STATUS/EXIT** button to remove the menu from the screen.

HELPFUL HINT

When a rating is turned **ON**, all higher ratings also will be turned on automatically. For example, if the **R** rating is turned on, the **NC-17** and **X** ratings also will be turned on.

All Movie Ratings can be turned **ON** or **OFF**.

Refer to page 30 for Movie Rating definitions.

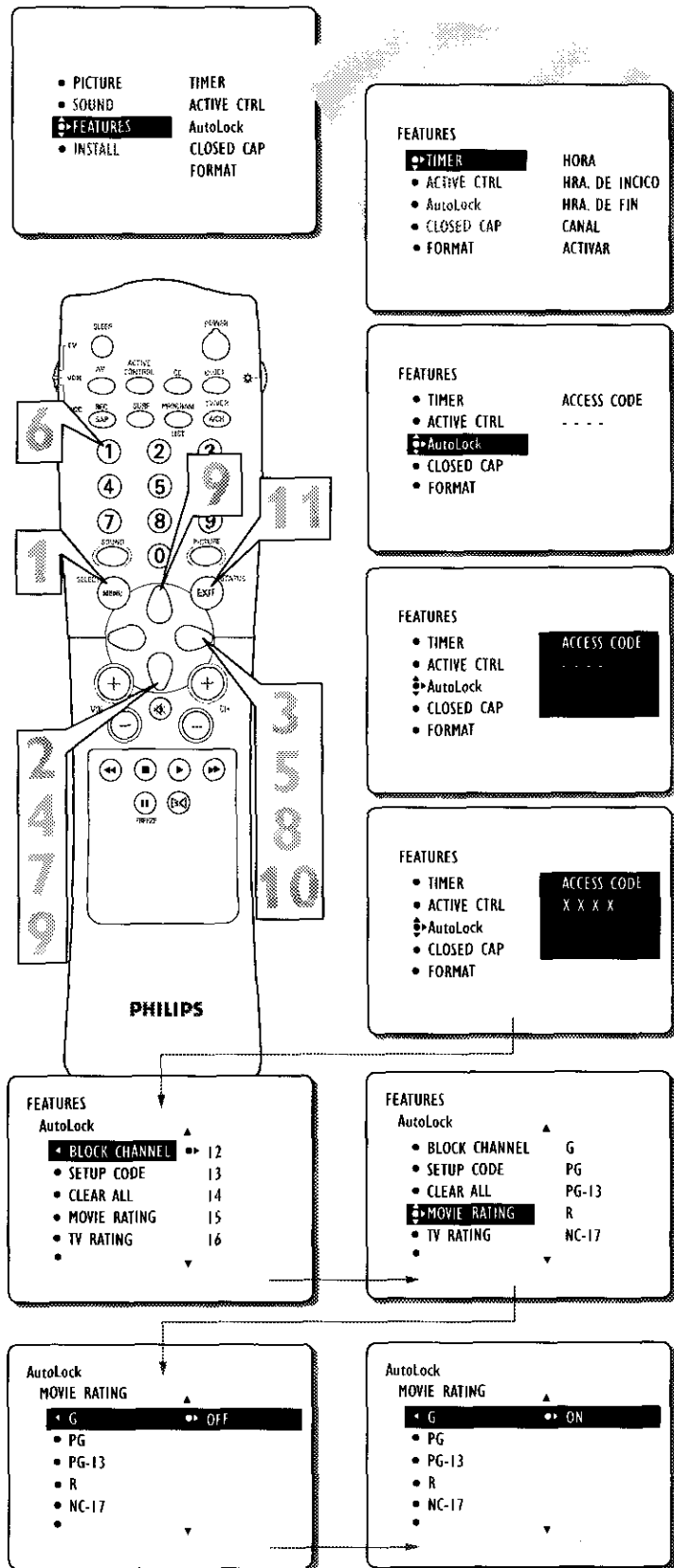

HOW TO BLOCK PROGRAMMING BASED ON TV RATINGS



You can select specific TV ratings that you want to censor by following these steps.

- 1 Press the **MENU** button on the remote control to show the onscreen menu.
- 2 Press the **CURSOR DOWN** button twice to highlight **FEATURES**.
- 3 Press the **CURSOR RIGHT** button and the menu will shift to the left.
- 4 Press the **CURSOR DOWN** button once to highlight the **AutoLock™** control.
- 5 Press the **CURSOR RIGHT** button again to highlight **ACCESS CODE**.
- 6 Enter your four-digit **ACCESS CODE**. **CORRECT** will flash very briefly and the menu will move to the left with **BLOCK CHANNEL** highlighted.
- 7 Press the **CURSOR DOWN** button repeatedly until **TV RATING** is highlighted.
- 8 Press the **CURSOR RIGHT** button and the menu will shift to highlight the **TV RATING** options.
- 9 Press the **CURSOR UP** or **DOWN** button to select a rating.
- 10 Press the **CURSOR RIGHT** or **LEFT** button to turn the block on the rating **ON** or **OFF**.

NOTE: More specific subratings (for violence, sexual content, dialogue, or fantasy violence) are available for TV-Y7, TV-PG, TV-14, and TV-MA. (Refer to page 30 for definitions.)

To access these subratings, with the main rating selected, press the **CURSOR RIGHT** button. Then, repeat steps 9 and 10 to turn the sub-ratings **ON** or **OFF**.

- 11 Press the **STATUS/EXIT** button to remove the menu from the screen.

HELPFUL HINT

When a rating is turned **ON**, all higher ratings also will be turned on automatically. For example, if the **R** rating is turned on, the **NC-17** and **X** ratings also will be turned on.

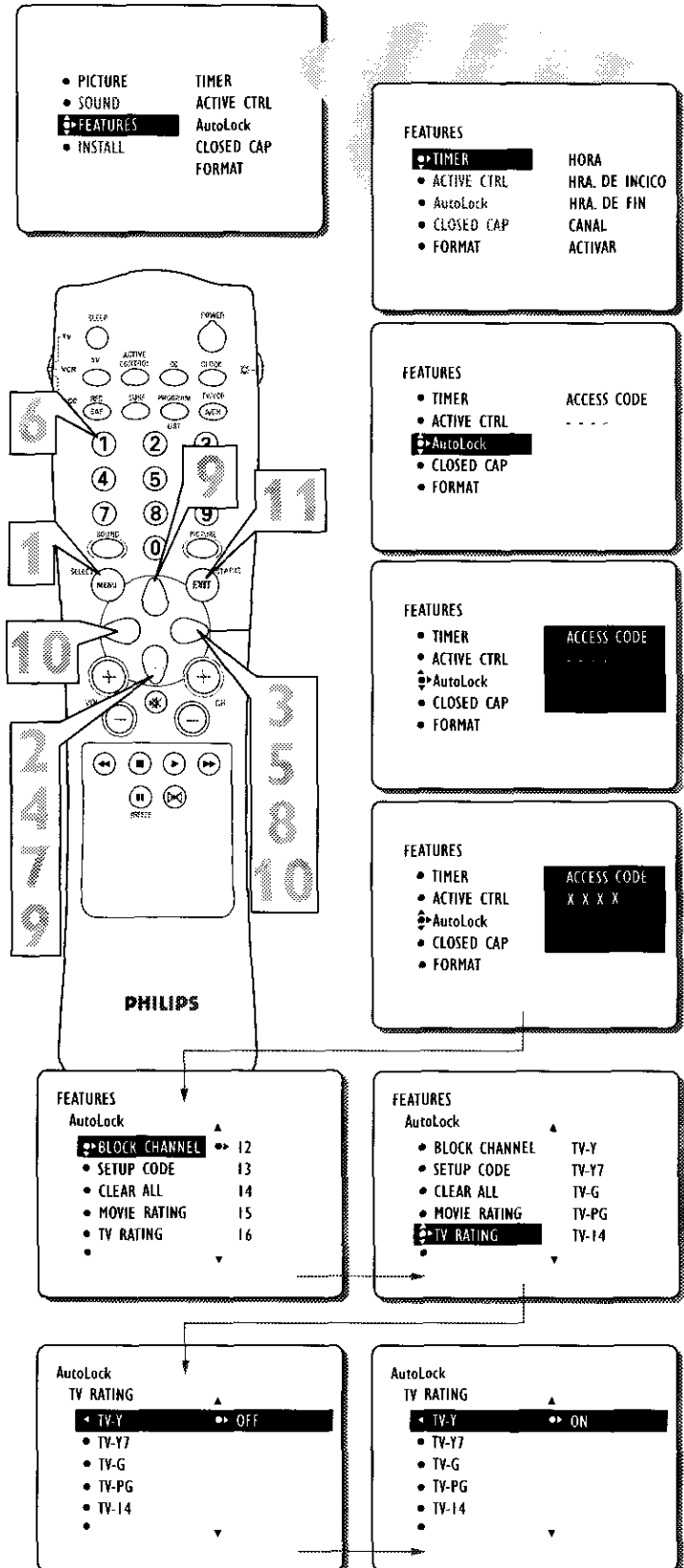



OTHER AUTOLOCK BLOCKING OPTIONS - BLOCKING CONTROL

The **BLOCKING** control is what can be thought of as the "master switch" for AutoLock™. This control affects the settings you have chosen for blocking programs according to movie ratings or TV ratings, or for blocking programs that have no rating or are unrated. When the **BLOCKING** control is OFF, the blocking or censoring of programs is disabled. When the **BLOCKING** control is ON, blocking will occur according to the settings you have chosen. Follow these steps to toggle **BLOCKING** OFF or ON.

- 1 Press the **MENU** button on the remote control to show the onscreen menu.
- 2 Press the **CURSOR DOWN** button twice to highlight **FEATURES**.
- 3 Press the **CURSOR RIGHT** button and the menu will shift to the left.
- 4 Press the **CURSOR DOWN** button once to highlight the AutoLock control.
- 5 Press the **CURSOR RIGHT** button again to highlight **ACCESS CODE**.
- 6 Enter your four-digit **ACCESS CODE** and the menu will move to the left with **BLOCK CHANNEL** highlighted.
- 7 Press the **CURSOR DOWN** button repeatedly until **BLOCK OPTIONS** is highlighted.
- 8 Press the **CURSOR RIGHT** button to enter the **BLOCK OPTIONS** menu. **BLOCKING** will be highlighted.
- 9 Press the **CURSOR RIGHT** or **LEFT** button to toggle **BLOCKING** ON or OFF.
- 10 Press the **STATUS/EXIT** button to remove the menu from the screen.

HELPFUL HINT

Remember, when the **BLOCKING** control is OFF, the blocking or censoring of programs is disabled. When the **BLOCKING** control is ON, blocking will occur according to the settings you have chosen.

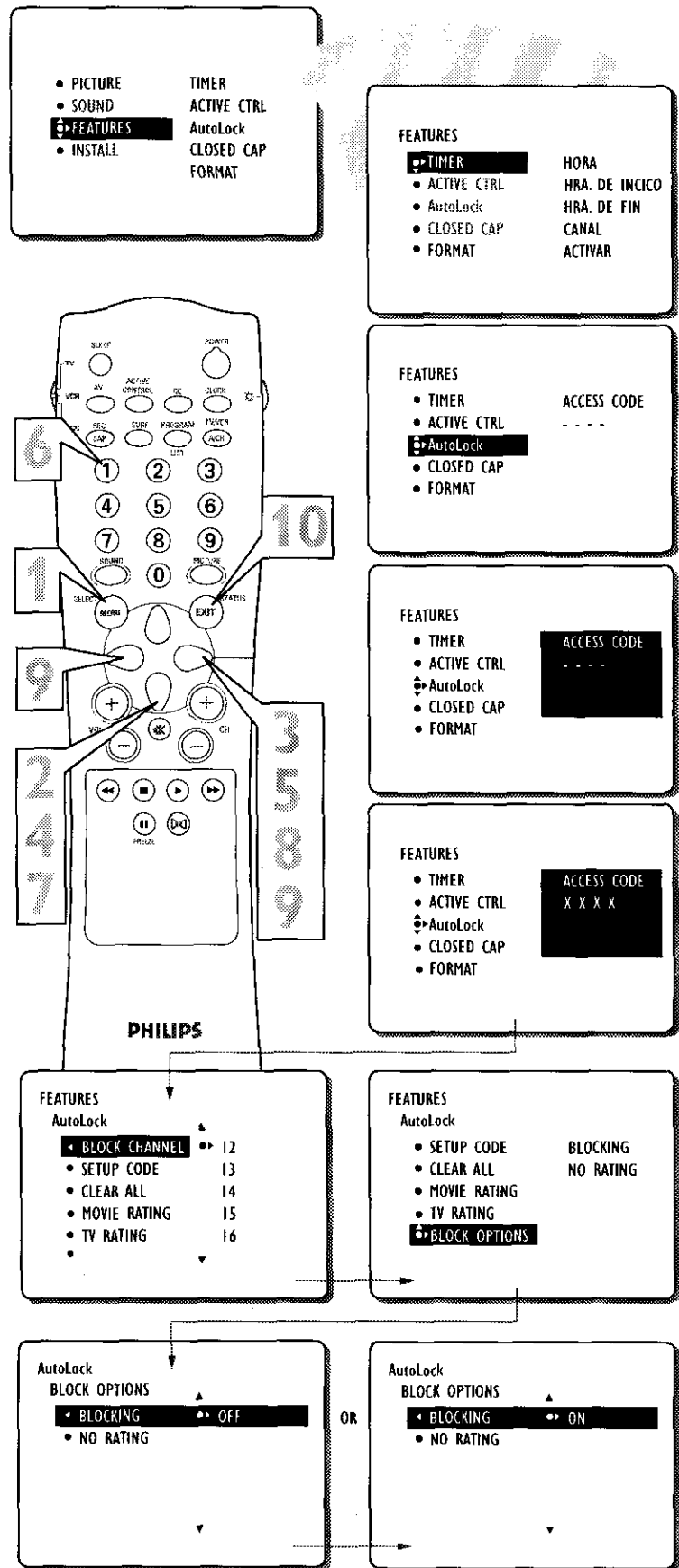

OTHER AUTOLOCK BLOCKING OPTIONS - NO RATING CONTROL



Some programming is not encoded with content advisory data by the MPAA (Motion Picture Association of America) or the television broadcasters (see the explanation on page 30). To block such programming, follow these steps.

- 1 Press the **MENU** button on the remote control to show the onscreen menu.
- 2 Press the **CURSOR DOWN** button twice to highlight **FEATURES**.
- 3 Press the **CURSOR RIGHT** button and the menu will shift to the left.
- 4 Press the **CURSOR DOWN** button once to highlight the **AutoLock** control.
- 5 Press the **CURSOR RIGHT** button again to highlight **ACCESS CODE**.
- 6 Enter your four-digit **ACCESS CODE** and the menu will move to the left with **BLOCK CHANNEL** highlighted.
- 7 Press the **CURSOR DOWN** button repeatedly until **BLOCK OPTIONS** is highlighted.
- 8 Press the **CURSOR RIGHT** button to enter the **BLOCK OPTIONS** menu. **BLOCKING** will be highlighted.
- 9 Press the **CURSOR DOWN** button to highlight the **NO RATING** option.
- 10 Press the **CURSOR RIGHT** or **LEFT** button to toggle **NO RATING** ON or OFF.
- 11 Press the **STATUS/EXIT** button to remove the menu from the screen.

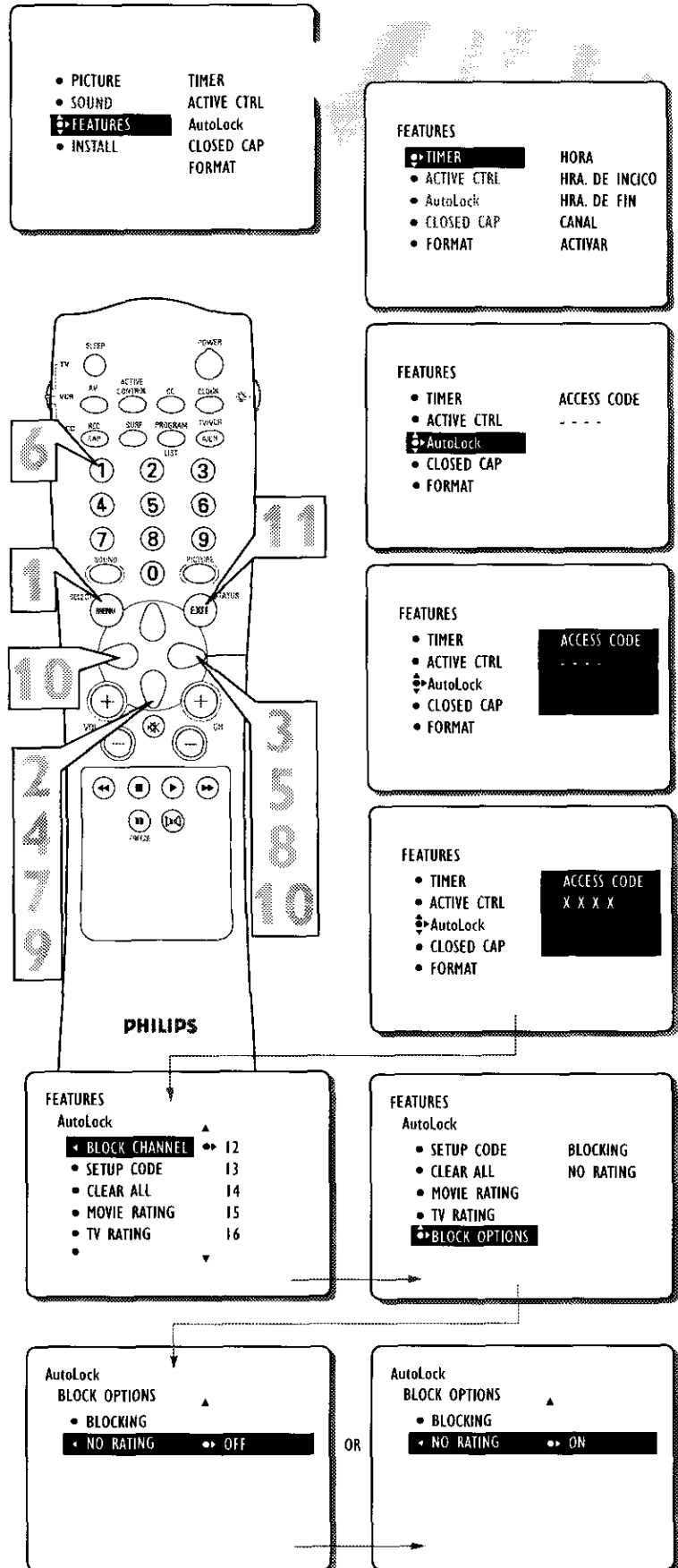



HOW TO REVIEW THE AUTOLOCK™ STATUS SCREEN

To remind you which ratings you have blocked and which Block Options you have selected, a review screen is available to review your AutoLock™ settings. To access this screen follow the steps below.

- 1 Press the STATUS/EXIT button on your remote control TWICE. Your AutoLock™ settings will appear on the screen.

NOTE: If you have blocked specific subratings, such as V for Violence in the TV-PG category, these blocked subratings will not appear in the review. The subratings however, are still blocked according to your selections.

- 2 After a few seconds, the settings will leave the screen automatically, or you can press the STATUS/EXIT button a third time to remove them from the screen.

HELPFUL HINT

The AutoLock™ Status screen will only appear if the BLOCKING option is set to ON. For details, see page 37.

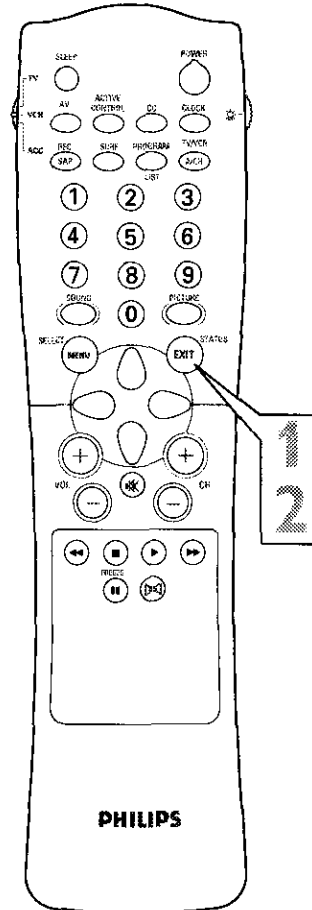
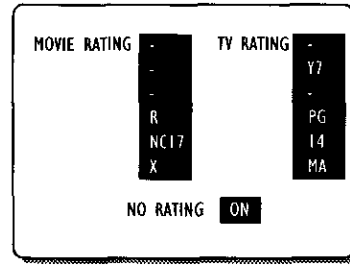

This display will appear after the step 1 above is completed if the AutoLock™ BLOCKING option is set to ON.

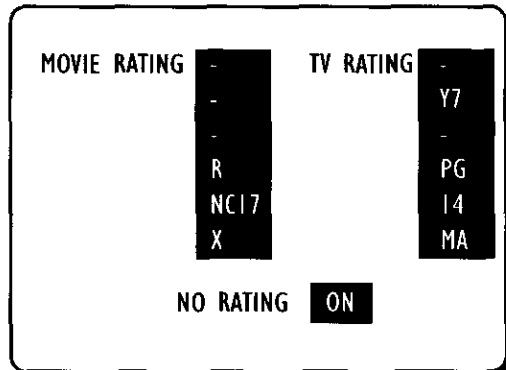

This display will appear after the step 1 above is completed if the AutoLock™ BLOCKING option is set to OFF.

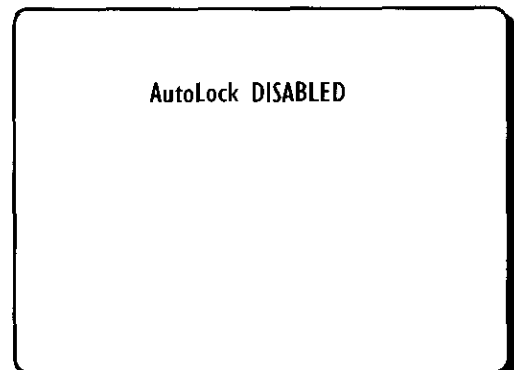

HOW TO USE THE CLOSED CAPTIONING CONTROL



Closed Captioning (CC) allows you to read the voice content of television programs on the TV screen. Designed to help the hearing impaired, this feature uses onscreen "text boxes" to show dialogue and conversations while the TV program is in progress.

NOTE: Not all TV programs and product commercials are broadcast with Closed Captioning (CC). Nor are all Closed Captioning MODES (CAPTION 1-4 or TEXT 1-4) necessarily being used by broadcast stations during the transmission of a program offering Closed Captioning. Refer to your area's TV program listings for the stations and times of shows being broadcast with Closed Captioning.

- 1** Press the **MENU** button on the remote control to show the on-screen menu.
- 2** Press the **CURSOR DOWN** button twice to highlight **FEATURES**.
- 3** Press the **CURSOR RIGHT** button and the menu will shift to the left.
- 4** Press the **CURSOR DOWN** button repeatedly until the **CLOSED CAP** control is highlighted.
- 5** Press the **CURSOR RIGHT** button again. The menu will shift to the left and **CAPTION MODE** will be highlighted.
- 6** Press the **CURSOR RIGHT** button to highlight **CAPTION MODES**.
- 7** Press the **CURSOR UP** or **CURSOR DOWN** button to select a **CAPTION MODE**: CC1, CC2, CC3, CC4, CC MUTE, TXT1, TXT2, TXT3, or TXT4. CC DISPLAY turns text OFF or ON if the TV station broadcasting on the channel is making **CLOSED CAPTIONING** available. With **CC DISPLAY** highlighted, press the **CURSOR RIGHT** button to toggle Closed Captioning ON or OFF.

NOTE: You also can press the **CC** button on the remote control to turn the **CC TEXT** option ON or OFF.

- 8** Press the **STATUS/EXIT** button to remove the menu from the screen.

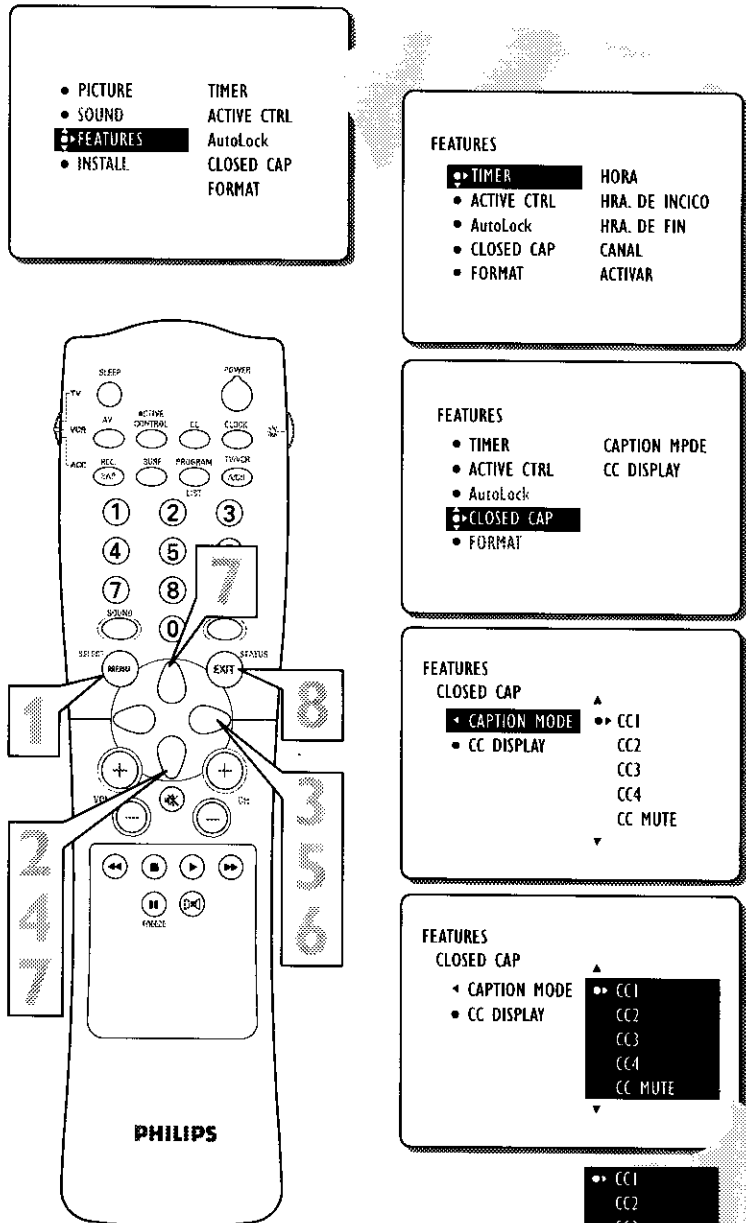

CAPTION Mode Example Display



TEXT Mode Example Display -
The TV screen will be blocked from viewing.

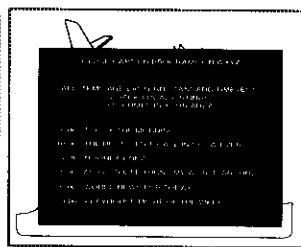

- CC1
- CC2
- CC3
- CC4
- CC MUTE
- TXT1
- TXT2
- TXT3
- TXT4



HOW TO USE THE SCREEN FORMAT CONTROL

You can change the screen format size to match the type of program you're watching. Select the normal 4:3 aspect ratio or expand the 4:3 aspect ratio to completely fill the screen. There also is a compressed 16:9 aspect ratio, which allows movies to be viewed in their full width (known as letter-box style).

- 1 Press the **MENU** button on the remote control to show the on-screen menu.
- 2 Press the **CURSOR DOWN** button twice to highlight **FEATURES**.
- 3 Press the **CURSOR RIGHT** button and the menu will shift to the left.
- 4 Press the **CURSOR DOWN** button repeatedly until the **FORMAT** control is highlighted.
- 5 Press the **CURSOR RIGHT** button repeatedly to toggle among the three screen format sizes – 4:3, EXPAND 4:3, or COMPRESS 16:9.
- 6 Press the **STATUS/EXIT** button to remove the menu from the screen.

HELPFUL HINT

The **FORMAT** control is not available for use with the AV 4 Inputs (AV4 Channel) if 1080i signal is detected.

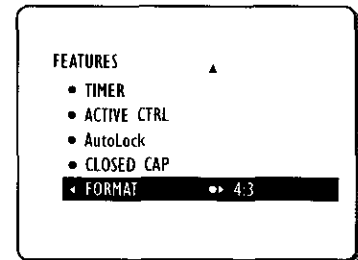
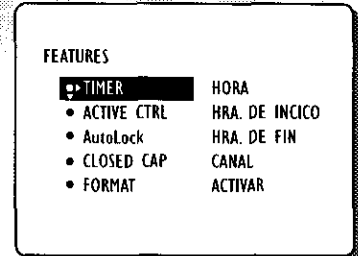
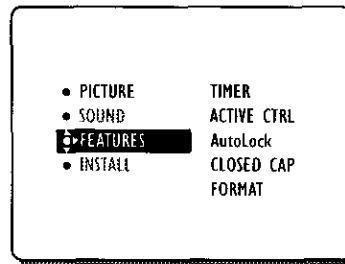

OR



OR

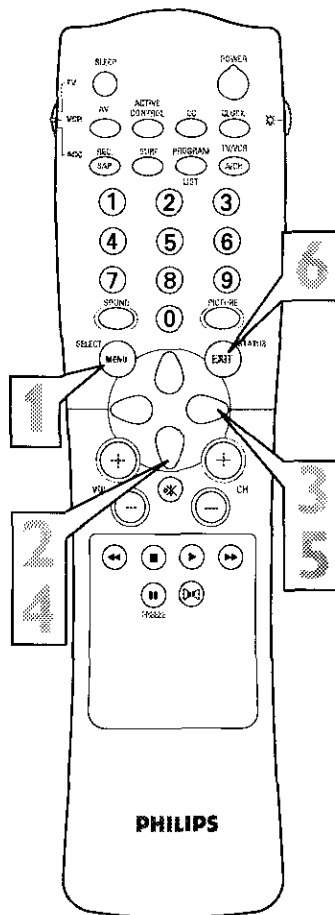

IMPORTANT NOTE:

Some DVD Discs are encoded with as much as 30% more video information to give the viewer the best possible picture quality. With the DVD Player in the 16:9 picture format, the playback of this type of disc (containing extra video information), can produce a number of small white lines in the upper portion of the black letterbox area. With some of these discs, this situation is unavoidable and it does not require a service call.



◀ FORMAT ▶▶ 4:3



◀ FORMAT ▶▶ EXPAND 4:3



◀ FORMAT ▶▶ COMPRESS 16:9

HOW TO SET THE SLEEP TIMER CONTROL



Have you ever fallen asleep in front of the TV, only to have it wake you up at two in the morning with a test pattern sound screeching in your ears? Well, your TV can enable you to avoid that discomfort by automatically turning itself off. With the Sleep Timer feature, you can set a timer to automatically switch the TV OFF after a period of time you choose (15-minute increments up to 60 minutes, then 30-minute increments up to 90 minutes, then 60-minute increments up to 240 minutes).

- 1** Press the **SLEEP** button on the remote control. The **SLEEP** timer onscreen display will appear in the upper part of the screen.
- 2** Within five seconds, press the **SLEEP** button repeatedly to pick the amount of time (15-minute increments up to 60 minutes, then 30-minute increments up to 90 minutes, then 60-minute increments up to 240 minutes) before the TV will turn itself off.

An onscreen countdown will appear during the last minute before the TV shuts itself off.

HELPFUL HINT

To see how many minutes remain before the TV shuts itself off, press the **STATUS/EXIT** button.

A Sleep Timer setting can be cancelled by pressing any button during the last minute of the operation.

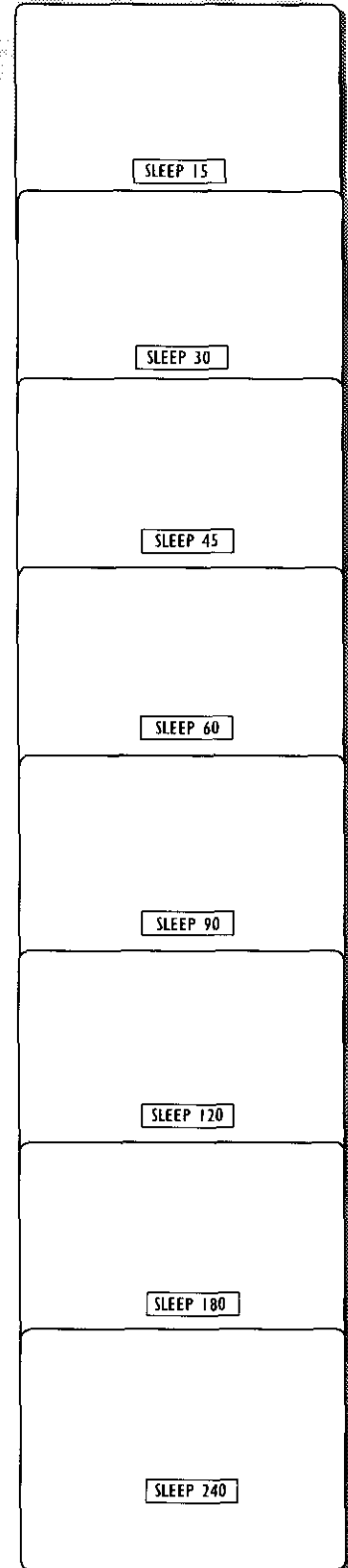
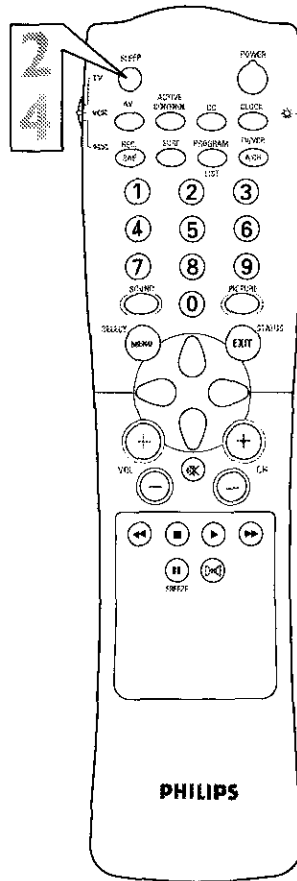
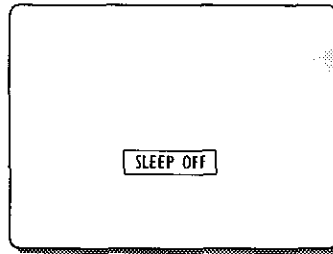

During the last minute of a SLEEP timer setting, an onscreen countdown will be displayed.

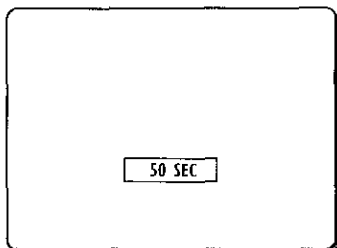

During the last 10 seconds of a SLEEP timer setting, an onscreen display will read GOOD BYE.





HOW TO USE THE FREEZE CONTROL

Have you ever wished you could freeze the picture on the television broadcast to write down a special telephone number or to capture a needed address? Your television will allow you to do just that with the press of just one button on the remote control.

- 1 With a signal on the television screen, simply **press the FREEZE button** on the remote control to stop the picture at any given moment.

The screen will read **"FREEZE ON"** momentarily and the picture frozen on the screen.

- 2 Press the **FREEZE button** on the remote control again to resume normal viewing.

The screen will read **"FREEZE OFF"** momentarily while the television displays a normal moving picture again.

HELPFUL HINT

After freezing a picture on the screen, when the FREEZE control is turned OFF, the normal signal programming will be shown at it's present time. The signal that was being shown while the picture was frozen will not be viewable.

If the FREEZE button is pressed when the AV4 Inputs (AV4 Channel) is tuned, the screen will read "FREEZE NOT AVAIL."

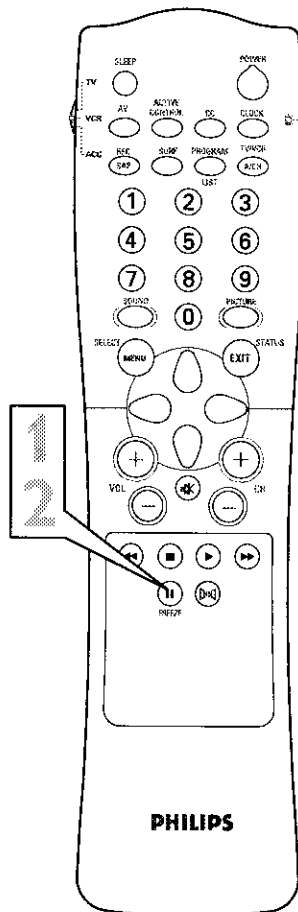
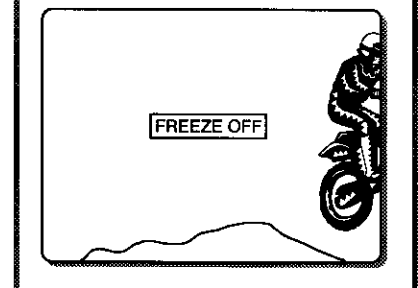
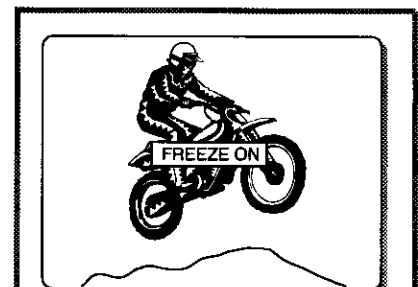
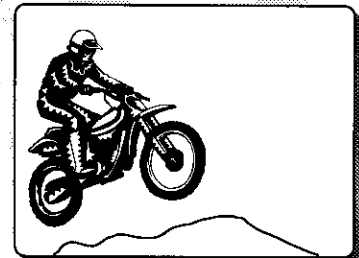
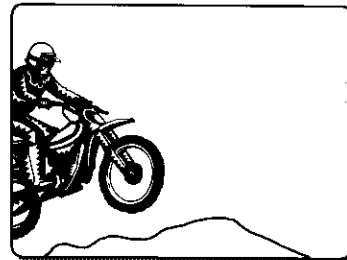

HOW TO USE THE AUTOPICTURE™ CONTROL



Whether you're watching a movie or a video game, your TV has automatic video control settings that will match with your current program source or content. AutoPicture™ quickly resets your TV's video controls for a number of different types of programs and viewing conditions that you may have in your home. The Movies, Sports, Weak Signal, and Multimedia AutoPicture™ controls have been preset at the factory to automatically adjust the TV's brightness, color, picture, sharpness, tint, and color temperature levels. The Personal AutoPicture™ settings are the ones that you made through the PICTURE options within the onscreen menu

- 1 Press the **PICTURE** button on the remote control. The current AutoPicture™ setting will appear in the middle of the screen.
- 2 Press the **PICTURE** button repeatedly to select either **PERSONAL**, **MOVIES**, **SPORTS**, **WEAK SIGNAL**, or **MULTIMEDIA** picture settings.

NOTE: The **PERSONAL** setting and the **PICTURE** options within the onscreen menu are the same. This is the only option in AutoPicture™ that can be changed. To adjust these settings, use the **PICTURE** options within the onscreen menu. All other settings are set up at the factory during production and cannot be adjusted.

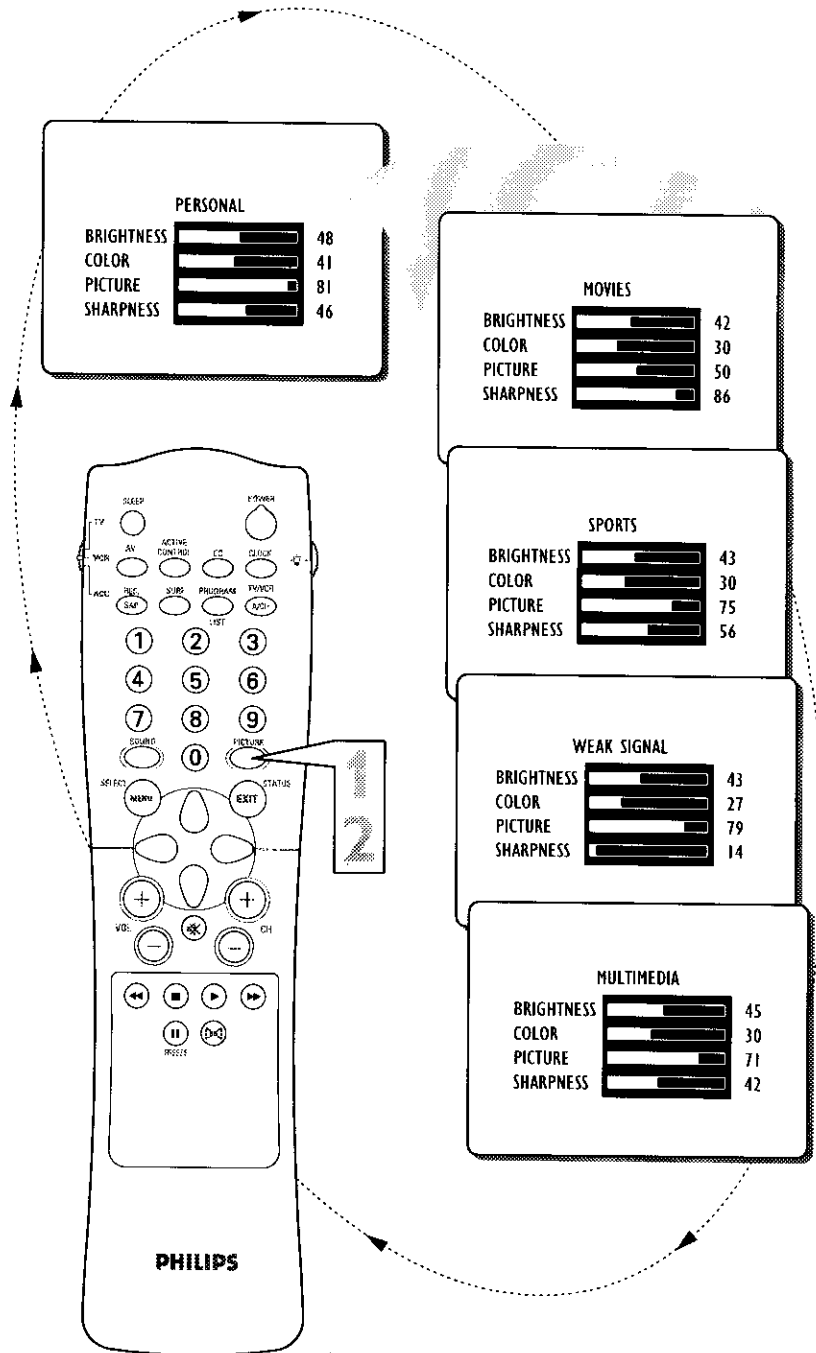

NOTE: The values shown in the diagram above are sample values only. Your television's values may vary and display different numbers.



HOW TO USE THE AUTO SOUND™ CONTROL

AutoSound™ allows you to select from three factory-set controls and a personal control that you set according to your own preferences through the onscreen Sound menu. The three factory-set controls (Voice, Music, and Theatre) enable you to tailor the TV sound so as to enhance the particular program you are watching. Follow these steps to select any of the options.

- 1** Press the **SOUND** button on the remote control. The current AutoSound™ setting will appear in the middle of the screen.
- 2** Press the **SOUND** button repeatedly to toggle among the four settings: PERSONAL, VOICE, MUSIC, or THEATRE.

Remember, only the PERSONAL control can be changed by the viewer. This changes the settings in the main onscreen menu's SOUND controls

HELPFUL HINT

AutoSound™ works only with the programs coming through the ANTENNA/CABLE (ANT) input on the rear of the TV (RF audio). It will not control the sound levels for the external connections.

✓ CHECK IT OUT

PERSONAL – presents the TV's sound according to the settings you make within the sound menu.

VOICE – brings voices to the forefront and emphasizes them. Moves music to the background.

MUSIC – emphasizes music over voices.

THEATRE – provides a balance between voices and music.

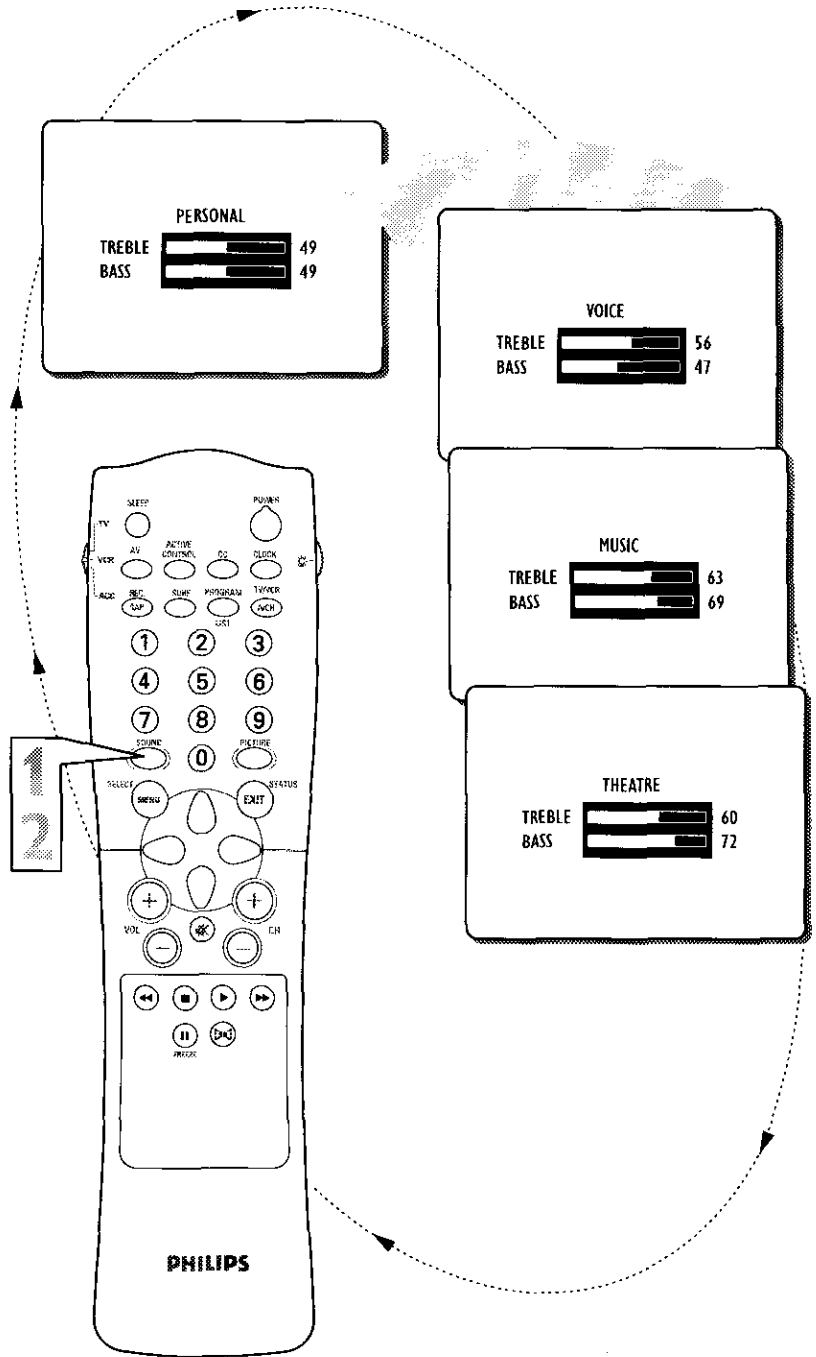

NOTE: The values shown in the diagram above are sample values only. Your television's values may vary and display different numbers.

HOW TO USE SURF CONTROL (AND ALTERNATE CHANNEL)



A list or series of previously viewed channels can be selected with the SURF button on your remote control. With this feature, you can easily switch between different TV channels that currently interest you. The SURF control allows you to set up to ten channels in its quick viewing list.

- 1 Press the CHANNEL(+) or (-) button (or the numbered buttons) to select a channel to add to the SURF list.
- 2 Press the SURF button on the remote control. The onscreen display may read, "SURF LIST EMPTY." The number of the current channel will be shown with "ADD?" to the right.
- 3 While the SURF list message or the SURF channel list appears on the screen, press the CURSOR RIGHT button to add the present channel to the SURF list.
- 4 If you want to delete the present channel from the SURF list, press the CURSOR RIGHT button again.

Repeat steps 1 through 3 to add more channels (up to 10) to the SURF list.

HELPFUL HINT

Along with regularly programmed channels, the external video source connections can be added to the SURF list. This means that the AV1, CVI, AV2, AV3, and AV4 channels can be added to your SURF list. Just tune to their channel and use the same procedure described on this page.

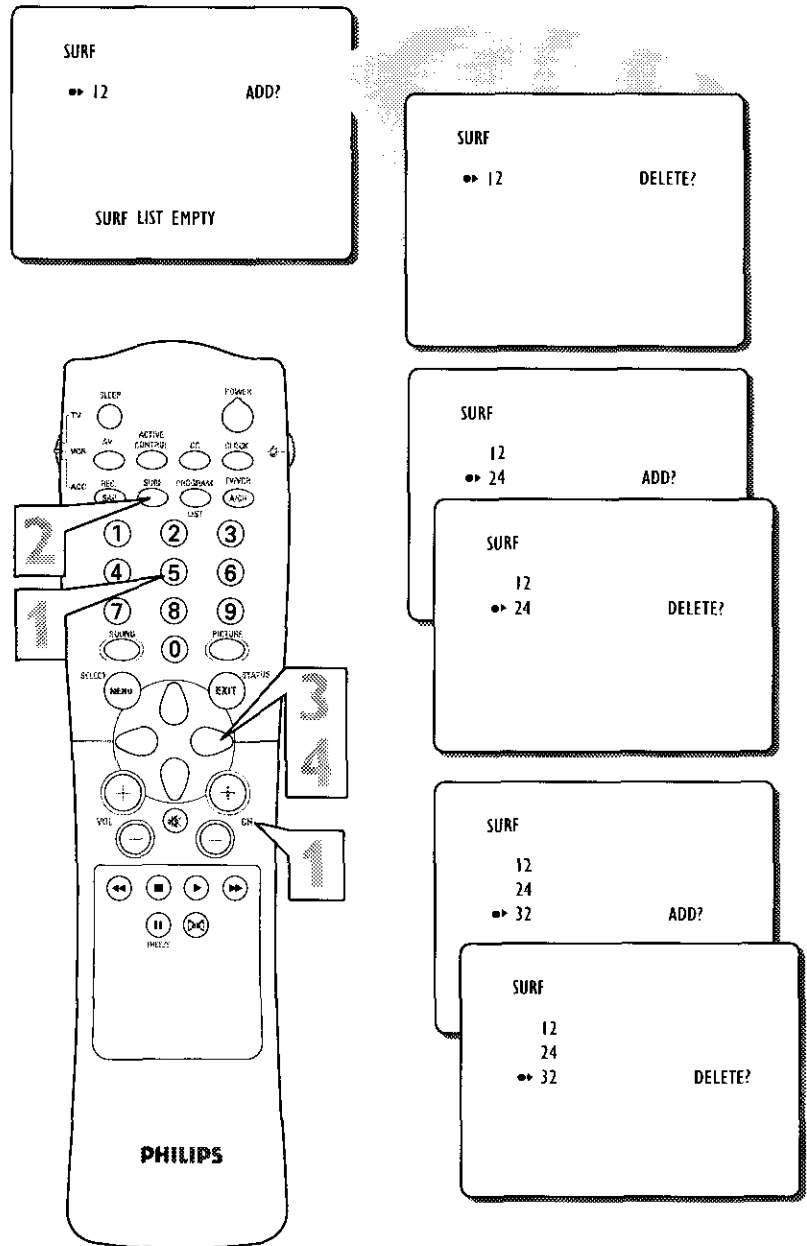

ALTERNATE CHANNEL BUTTON

Your remote also has an A/CH (Alternate Channel) button. Pressing this button will toggle between the current and one previous channel.

- 1 Press the A/CH button toggle between the present channel and the last previously viewed channel.

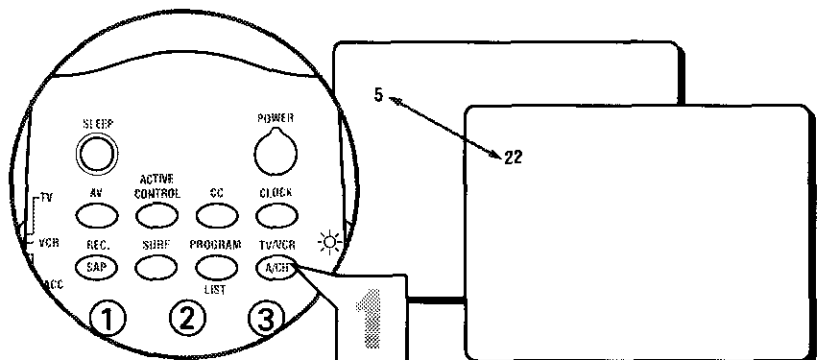



USING THE REMOTE WITH ACCESSORY DEVICES - DIRECT ACCESS

Your remote control is capable of working your TV and many other devices that respond to infrared remote control commands, such as VCRs, cable boxes, satellite systems, and DBS. Your remote may be already, as is, to work an accessory device, or you may need to use one of the methods ("Code Entry" or "Search") explained on pages 47 and 48.

First, try this simple test to see if your TV remote control will give you direct access to the accessory device's functions, or if you will need to try another method in order to set up your TV remote control for that capability.

- 1** Place the TV/VCR/ACC mode switch in the proper position.
- 2** Point the remote control at the remote sensor window of the accessory device and press the POWER button.
- 3** Does the remote control turn the device ON?

If YES, stop and try other function buttons on the remote. If they also work the device, then the remote is ready and no further steps are needed.

If NO, go to the next page to try the Code-Entry method.

HELPFUL HINT

It is recommended that you use Philips brand external accessory devices with your Philips television to insure proper remote control functions. If you are using Philips brand accessory devices, your remote control should be ready to use with these devices.

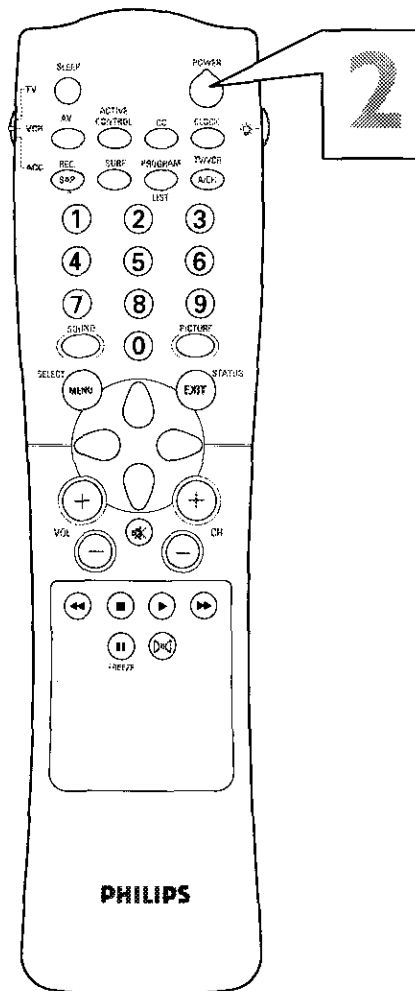
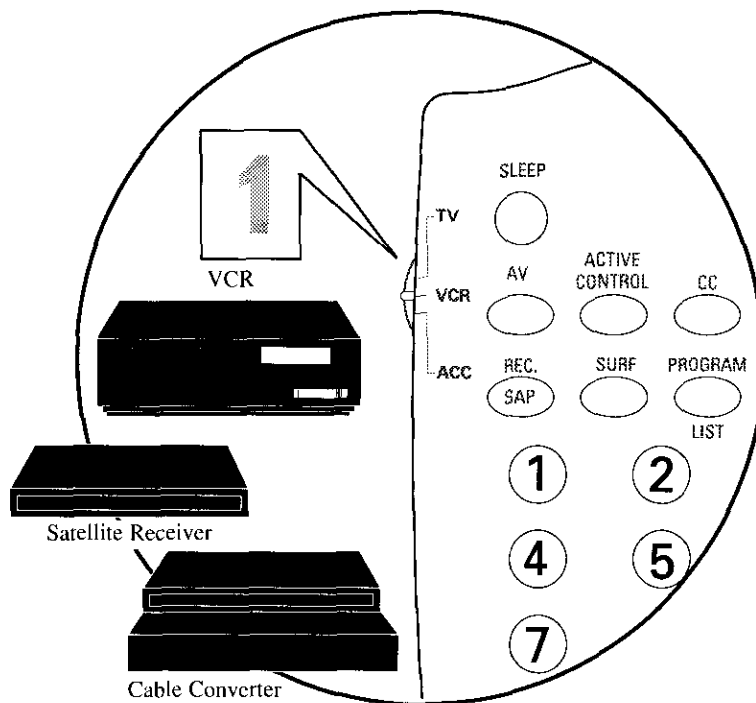

USING THE REMOTE WITH ACCESSORY DEVICES - CODE ENTRY



Follow these simple steps to enter a three-digit Accessory Device Code Number that will allow you to use your TV remote to work the functions of an accessory device. Please read through the steps once before performing them.

- 1** Look up a three-digit Accessory Device Code Number for the accessory device (found on pages 49-50) whose functions you want to work with your TV's remote control.
- 2** Press the REC(ord)/SAP button on the remote control and release.
- 3** Press the SOUND button on the remote within 30 seconds, then release.
- 4** Enter the three-digit Direct-Entry Code Number for your desired device. The remote is now ready to send commands to the unit.
- 5** Point the remote at the remote sensor window of the device. Then press the POWER button on the remote to turn the unit ON.

NOTE: If the process just explained doesn't work the first time, repeat the same Accessory Device code number.

If after a second try the TV remote control does not operate your accessory device, see if other three-digit Accessory Device Code Numbers are shown for your device on the list pages 49-50 and repeat the steps above using a new number.

If after repeated attempts this method does not work for you, go to the next page and follow the steps for using the Search method to set up your remote control.

HELPFUL HINT

It is recommended that you use Philips brand external accessory devices with your Philips television to insure proper remote control functions. If you are using Philips brand accessory devices, your remote control should be ready to use with these devices.



VCR



Satellite Receiver

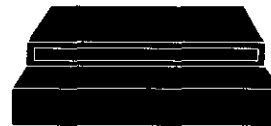

Cable Converter

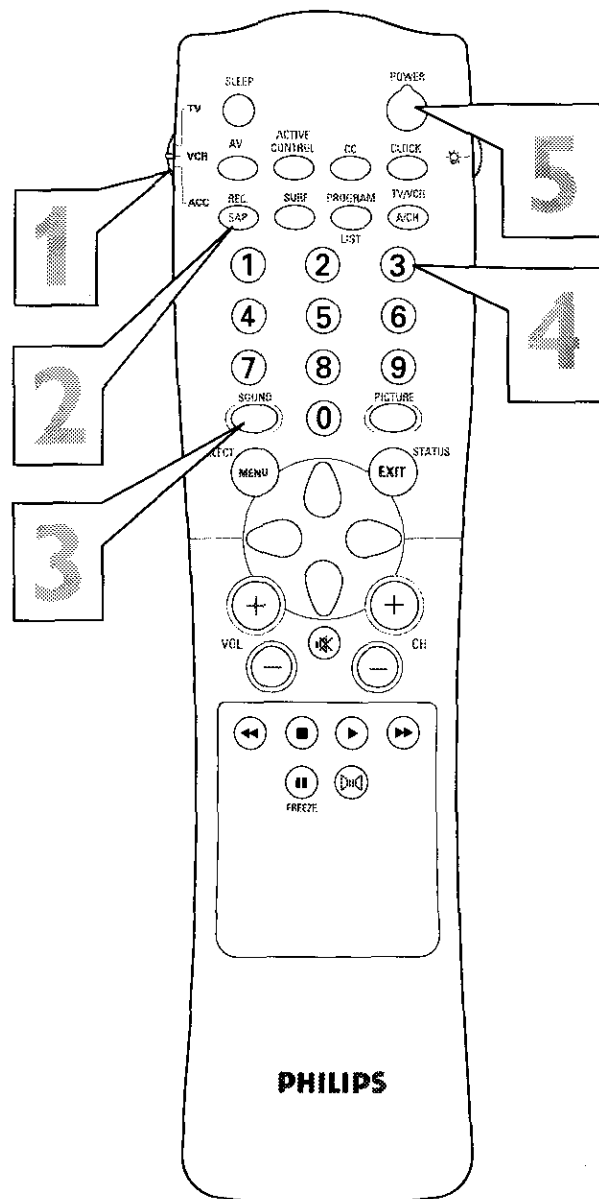



USING THE REMOTE WITH ACCESSORY DEVICES - SEARCH

Follow these simple steps to have your TV remote search for the code it needs to work the functions of your accessory device. Please read through the steps once before performing them.

NOTE: The Search method works only with devices equipped with channel display indicators or channel display capability.

- 1** Press the **POWER** button on the device you're attempting to program to turn it ON.
- 2** Slide the **TV/VCR/ACC** mode switch to the **VCR** position if you're setting up a VCR or to the **ACC** position if you're setting up any other accessory device.
- 3** Press the **REC(ord)/SAP** and **SOUND** buttons **simultaneously** and hold them down. The device will begin to change channels after the remote identifies the correct code.
- 4** When the channels start to change, release the **REC(ord)/SAP** and **SOUND** buttons.

NOTE: Don't let the device scan up more than five channels. If you do, the remote control may pass up the correct code, and another two-minute search cycle will have to be done.

If no channel change happens within two minutes, repeat steps 1-4. Should a channel change still not occur, the remote will not work the desired device.

HELPFUL HINT

Don't let the device scan up more than five channels. If you do, the remote may pass up the right code, and another two-minute search cycle will have to be done.

If no channel change happens within two minutes, repeat steps 1-4. Should a channel change still not occur, the remote control will not work the desired device.

It is recommended that you use Philips brand external accessory devices with your Philips television to insure proper remote control functions. If you are using Philips brand accessory devices, your remote control should be ready to use with these devices.

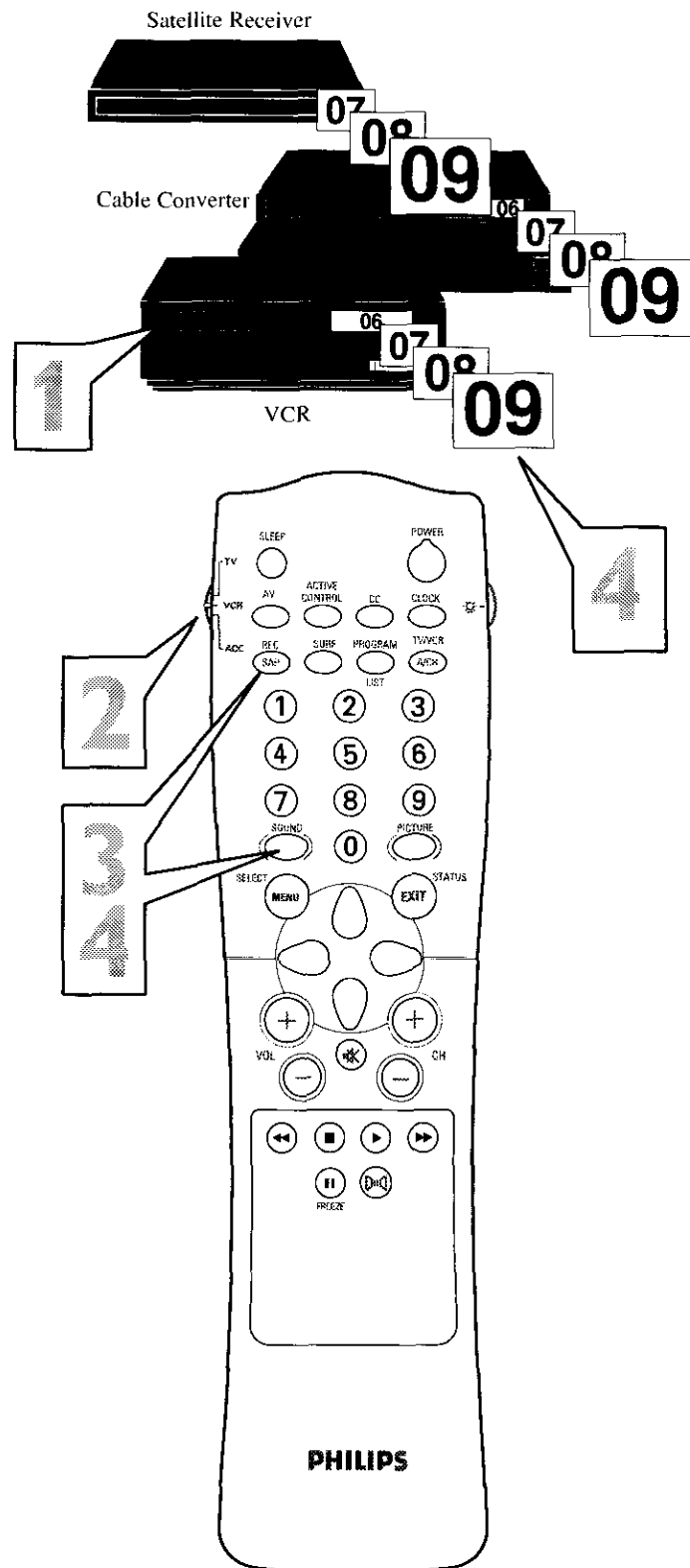

CODE-ENTRY CODE LIST FOR ACCESSORY DEVICES



VCR	REMOTE CODE NO.	VCR	REMOTE CODE NO.	VCR	REMOTE CODE NO.
Admiral	.048	Loewe	.004	Sanyo	.046, 047, 104, 240, 268
Advantz	.358	Logik	.004, 072	Saville	.352
Adventure	.000	MEL	.035	Scott	.043, 045, 121, 164, 211, 212
Aiko	.278	MGA	.043, 061	Sears	.000, 035, 037, 042, 046, .047, 054, 066, 104, 105
Aiwa	.000, 037, 307, 348, 352	MGN Technology	.240	Sharp	.046, 062
Akai	.041, 049, 053, 061, 106, 315	MTC	.000, 240	Shintom	.072
Alba	.352	Magnavox	.000, 035, 081, 146, 181	Shogun	.051, 240
Amercian High	.035	Marta	.037	Shoral	.004
Amstrad	.325, 332	Matsui	.004, 348, 352	Siemens	.003
Asha	.240	Matsushita	.035, 162, 454	Singer	.072
Audiovox	.037	Memmorex	.307	Sinudync	.004
Baird	.107	Memorex	.000, 035, 037, 039, 046, .047, 048, 104, 240, 266, 307	Sony	.000, 011, 022, 032, 033, .034, 035, 253, 275
Beaumont	.240	Metz	.003, 347	Sunkel	.348
Bell & Howell	.104	Minolta	.042, 105	Sunpak	.253
Blaupunkt	.003, 006, 154	Mitsubishi	.043, 061, 067, 075, 173, 443	Sylvania	.000, 035, 043, 081, 103, 110
Brandt	.187, 320, 321	Motorola	.035, 048	Symphonic	.000
Broksonic	.121, 184, 211, 295, 361	Multitech	.000, 072	TMK	.036, 208, 240
Bush	.352	NAD	.058	Tatung	.041
CCE	.072, 278	NEC	.036, 040, 041, 067, 104	Teac	.000, 041
Calix	.037	Nikko	.037	Technics	.035, 162
Canon	.035	Nikon	.034, 253	Teknika	.000, 035, 037
Capehart	.020	Noblex	.240	Telefunken	.187, 320, 321
Carver	.081, 146	Nordmende	.297, 320, 321	Tansal	.322
Citizen	.037, 278	Okano	.346	Thomas	.000
Colt	.072	Olympus	.035, 226	Thomson	.320
Combitach	.352	Optimus	.037, 048, 058, 104, .162, 432, 454	Toshiba	.043, 045, 066, 212, 366
Craig	.037, 047, 072, 240, 271	Optonica	.062	Totavision	.037, 240
Curtis Mathes	.035, 041, 060	Orion	.004, 295, 348, 352, 479	Towada	.322
Cybermax	.051, 240	Panasonic	.035, 077, 162, 225, .226, 378, 454	Unitech	.240
Daewoo	.020, 045, 276	Penney	.035, 037, 038, 040, .042, 065, 105	Universum	.325
Daytron	.020	Pentax	.042, 065, 105	Vector	.045
Dennon	.042	Philco	.035	Vector Research	.038, 040
Dynatech	.000	Philips	.035, 062, 081, 110, 403	Video Concepts	.040, 045, 061
Electroponic	.037	Pilot	.037	Videosonic	.240
Emerex	.032	Pioneer	.058, 067	Wards	.000, 035, 042, 047, 048, 060, 062, .072, 081, 149, 161, 212, 240
Emerson	.000, 002, 036, 037, 043, 061, .068, 088, 121, 164, 208, 209, .211, 212, 278, 295, 361, 479	Portland	.020	XR-1000	.000, 035, 072
Ferguson	.107, 320, 321	Profax	.322	Yamaha	.038
Fisher	.047, 054, 066, 104	Profitronic	.240	Zenith	.000, 033, 034, 039
Fuji	.033, 035	Protoc	.072		
Funai	.000	Pulsar	.039, 051	CABLE CONVERTOR	REMOTE CODE NO.
GE	.035, 060, 065, 202	Quarter	.046	ABC	.001, 003, 007, 008, .011, 013, 014, 017
Garrard	.000	Quartz	.046	Aliegio	.153
Go Video	.232, 279, 432	Quasar	.035, 077, 162, 454	Andover	.544
Gold Star	.037, 038	RCA	.042, 060, 065, 077, .105, 106, 149, 202	Antronix	.022
Gradiente	.000, 406	Radio Shack	.000, 037	Archer	.022, 153
Grundig	.003, 007, 195, 347	Radix	.037	Balcor	.056
HI-Q	.047	Randex	.037	British Telecom	.105
Harley Davidson	.000	Realistic	.000, 035, 037, 045, 047, .048, 062, 066, 104	Cable Star	.056
Harman/Kardon	.038, 075	Ricoh	.034, 253	Cablantenna	.022
Harwood	.068, 072	Runco	.039	Cabletime	.161, 271, 377, 448
Headquarter	.046	SEG	.322	Cableview	.022
Hinari	.004, 352	SEI	.004	Century	.153
Hitachi	.000, 004, 041, 042, .065, 105, 168, 235	STS	.042	Citizen	.153
Ingersol	.004	Saba	.297, 320, 321	Clyde	.086
JVC	.008, 041, 067, 208, 384, 486	Saisho	.004	Colour Voice	.025, 031
Jensen	.041	Salora	.075	Comtec	.274
KEC	.037, 278	Samsung	.045, 051, 053, 240	Comtronics	.040
KLH	.072	Sanky	.039, 048	Contec	.019
Kenwood	.038, 041, 067, 384	Sansui	.000, 041, 067, 271	Cryptovision	.600
Kodak	.035, 037			Deecat	.423
LXI	.037				
Lloyd's	.000, 206				



CODE-ENTRY CODE LIST FOR ACCESSORY DEVICES

CABLE CONVERTOR	REMOTE CODE NO.
Eastern	.002, 274
Everquest	.015, 040
Filmnet	.443
Focus	.400
France Telecom	.451
GC Electronics	.056
GEC	.086
Ganard	.153
Gemini	.015, 070, 242
General Instrument	.011, 276, 476
Gold Star	.040
Grundig	.529
Hamlin	.009, 020, 034, 259
Hitachi	.011
Hytex	.007
Jasco	.153
Jerrold	.003, 011, 012, 014, .015, 024, 276, 476
M.N.E. T.	.443
MNet	.443
Macon	.033
Magnavox	.027, 032, 334
Memorex	.000
Movie Time	.063
NSC	.063, 070
Oak	.007, 019
Optimus	.021
Panasonic	.000, 021, 107
Paragon	.000
Philips	.025, 027, 031, 153, 242, 290, 334
Pioneer	.533, 753
Popular Mechanics	.400
Pulsar	.000
RCA	.021
Radio Shack	.015
Recoton	.400
Regal	.020, 259
Regency	.002
Rembrandt	.011, 070
Runco	.000
SL Marx	.040
Salora	.382
Samsung	.040
Satbox	.375
Scientific Atlanta	.008, 017, 477
Signal	.015, 040
Signature	.011
Sprucer	.021
Star Sight	.542
Starcom	.003, 015
Stargate	.015, 040
Starquest	.015
Sylvania	.001
TV85	.063
Tandy	.258
Tele+1	.443
Teleservice	.281
Teleview	.040
Texscan	.001
Timeless	.274
Tocom	.012, 013, 059
Toshiba	.000
Tudl	.286
Tusa	.015
Unike	.022, 153

CABLE CONVERTOR	REMOTE CODE NO.
United Artists	.007
United Cable	.003
Universal	.022, 056, 153, 191
Videoway	.250
Viewstar	.027, 063, 258
Visi Cable+	.461
Westminster	.105
Wolsey Gaine	.544
Zenith	.000, 054, 525
Zentek	.400

DBS	REMOTE CODE NO.
Alpha Star	.772
Echostar	.775
HTS	.775
Hitachi	.819
Hughes Network System	.749
Jerrold	.627
Magnavox	.722, 724
Memorex	.724
Panasonic	.701
Philips	.722, 724
Primestar	.627
RCA	.566
Sony	.639
Toshiba	.790
Uniden	.724

SATELLITE	REMOTE CODE NO.
AST	.351
Akai	.515
Alba	.352, 515, 613
Aldea	.288
Amstrad	.080, 252, 345, 461, 509, 689
Ankaro	.220, 288, 369
Anitron	.183
Armstrong	.243
Astra	.108
Avalon	.396
Axis	.369
BT	.515, 668
Beko	.189
Best	.369
Boca	.243, 513
Bush	.067
Cambridge	.344, 515
Channel Master	.362
CommLink	.288
Connexions	.396
Conrad	.607
Crown	.243
DDC	.362
DNT	.396
Echostar	.396
Ferguson	.067, 183, 189, 336
Fidelity	.252
Finlux	.108, 397
Fuba	.369, 396
G-Bat	.183
Galaxis	.286
Gooding	.571
Grundig	.173, 189, 571, 750
Hinari	.183

SATELLITE	REMOTE CODE NO.
Hirschmann	.397, 573
Houston	.668
Huth	.220, 243, 268
ITT	.108
Intervision	.592
JVC	.515, 571
Kathrein	.092, 504, 622, 658
La Sat	.513, 607
Lennox	.592
Lupus	.369
Luxor	.108, 573
Manhattan	.592
Maspro	.092, 336, 750
Matsui	.571
Mediamarkt	.248
Minerva	.571
Mintec	.576
Morgan's	.243, 513
Newhaus	.220
Nikko	.360, 713
Nokia	.108, 397, 573
Nordmende	.362
Orbitech	.501
Pace	.067, 183, 336, 455, 791
Paliadium	.571
Palsat	.501
Philips	.200, 292, 571, 750
Phonotrend	.288, 592
Plasmatic	.442
Proset	.288
Quadral	.362, 628
RFT	.220, 288
Radix	.396
SAT	.351, 461
SEG	.369
Saba	.336
Salora	.108
Satec	.183
Schwaiger	.183, 504
Seemann	.396, 578, 626
Skymaster	.288, 626
Sony	.704
Star Trak	.421
Strong	.421
Sunstar	.513
Tantec	.336
Techni Sat	.262, 501
Telcka	.243, 613
Tonna	.668
Triad	.351
Universum	.571
Vtech	.351
Wisi	.351, 396

DVD	REMOTE CODE NO.
Kenwood	.534
Mitsubishi	.521
Panasonic	.490
Philips	.539
Pioneer	.550
RCA	.522
Sony	.552
Toshiba	.503

REMOTE CONTROL VCR SPECIFIC BUTTONS



When using the TV remote control with a VCR, first make certain it is set to control your VCR (by the REMOTE CODE or SEARCH method).

1 Set the TV/VCR/ACC mode switch to VCR on the remote control.

2 Point the top of the remote toward the front of the VCR (remote sensor window) when pressing the buttons.

VCR System Switch

Set in the VCR position to send remote commands to the VCR.

Record Button

Hold the REC(ord/Sap) and PLAY ► buttons down to begin a VCR recording.

Play Button ►

Press to begin playback of a videotape.

Rewind Button ◀◀

Press to rewind tapes. For some VCR's, the STOP button may have to be pressed first, then REWIND. In playback mode, hold down the button to view the picture moving rapidly in reverse.

Stop Button ■

Press to stop the motion of a tape in playback, rewind, fast forward, and so on.

HELPFUL HINT

Remember, the VCR buttons on the remote will not operate your VCR if those features are not found on your VCR remote control.

NOTE: All VCR functions (particularly Search, Rewind, Fast Forward, etc.) will operate the same as with the original VCR remote control provided with the VCR.

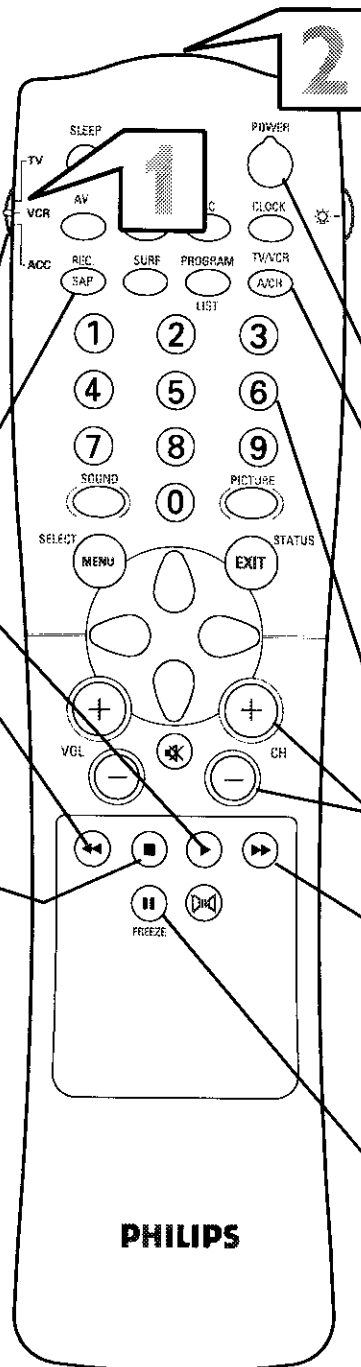

Power Button

Press to turn the VCR ON and OFF.

TV/VCR Button

Press while in the VCR mode (the VCR indicator on the front of the unit will light) to view the playback of a tape. Press again to place in the TV position (the VCR indicator light will go off) to view one program while recording another program.

Number Buttons

Press buttons for the direct selection of VCR channels.

Channel + and - Buttons

Press to scan up or down through the VCR channel numbers.

Fast Forward Button ►►

Press to rapidly advance the tape. For some VCRs, you may need to press the STOP button first, then the FAST FORWARD button. In playback mode, hold the button down to view the picture moving rapidly in the forward direction.

Pause Button ||

Press to temporarily stop the tape during a playback or recording. Press again to release Pause.



TROUBLESHOOTING

No Power

- Check the TV power cord. Unplug the TV, wait 10 seconds, then reinsert the plug into the outlet and push the POWER button again.
- Check that the outlet is not on a wall switch.
- Be sure the fuse is not blown on the AC power strip, if one is being used.

No Picture

- Check antenna connections. Are they properly secured to the TV's ANT 75Ω plug?
- Check the TUNER MODE control for the correct tuner setting.
- Try running the Auto Program feature to find all available channels.
- Press the AV button on the remote to make sure the correct signal source is selected (FRONT or Current Channel).

No Sound

- Check the VOLUME buttons.
- Check the MUTE button on the remote control.
- If you're attempting to hook up auxiliary equipment, check the audio jack connections located on the front of the TV.

Remote Does Not Work

- Check the batteries. If necessary, replace them with AA Heavy Duty (Zinc Chloride) or Alkaline batteries.

Remote Does Not Work Continued

- Clean the remote control and the remote control sensor window on the TV.
- Check the TV power cord. Unplug the TV, wait 10 seconds, then reinsert the plug into the outlet and push the POWER button again.
- Be sure the fuse is not blown on the AC power strip, if one is being used.
- Check to be sure the TV outlet is not on a wall switch.

TV Displays Wrong Channel or No Channels Above 13

- Repeat channel selection.
- Add the desired channel numbers (using the CHANNEL EDIT control) into the TV's memory.
- Check to be sure the TUNER MODES are set to the CABLE option and run the Auto Program feature to find all available channels.

TV Displays white lines in letterbox when viewing a DVD disc

- Some DVD Discs are encoded with as much as 30% more video information to give the best possible picture quality. With the DVD Player in the 16:9 picture format, the playback of this type of disc with extra video information, can produce a number of small white lines in the upper portion of the black letterbox area. With some of these discs, this situation is unavoidable and it does not require a service call.

CARE AND CLEANING

WARNING Concerning Stationary Images on the TV Screen:

Do not leave stationary or letterbox images on screen for extended periods of time. This can cause uneven picture-tube aging.

Normal use of the TV should involve the showing of pictures that contain constantly moving and changing images that fill the screen. Be careful not to leave nonmoving images on screen for extended periods of time, or to display the same images on screen too frequently, because subtle ghost images can be left on the picture tubes. Sources of stationary images may be DVD disks, laser disks, video games, CD-i disks, videotapes, digital television boxes, broadcast channels, cable channels, satellite channels, and others. **Here are some examples of stationary images (this is not an all-inclusive list; you may encounter others in your viewing):**

- **DVD menus**—listings of DVD disk content
- **Letterbox black bars**—shown at the top and bottom of the TV screen when a wide screen (16:9) movie is viewed on a TV with standard (4:3) aspect ratio.
- **Video-game images and scoreboards**
- **Television station logos**—present a problem if they are bright and stationary; moving or low-contrast graphics are less likely to cause uneven aging of the picture tube
- **Stock-market tickers**—presented at the bottom of the TV screen
- **Shopping channel logos and pricing displays**—bright and shown constantly or repeatedly in the same location on the TV screen.

PLACEMENT OF THE TV

- To avoid cabinet warping, cabinet color changes, and increased chance of set failure, do not place the TV where temperatures can become excessively hot; for example, in direct sunlight or near a heating appliance.
- Be sure to allow a free flow of air to and from the perforated back cover of the set.

CLEANING

- To avoid possible shock hazard, be sure the TV is unplugged from the electrical outlet before cleaning.
- Regularly dust the TV with a dry, nonscratching duster to keep the TV clean.
- When cleaning the TV, take care not to scratch or damage the screen surface. Avoid wearing jewelry or using anything abrasive. Do not use household cleaners. Wipe the front screen with a clean cloth dampened with water. Use even, easy, vertical strokes when cleaning.
- Gently wipe the cabinet surfaces with a clean cloth or sponge dampened in a solution of cool, clear water and a mild soap or detergent. Use a clean, dry cloth to dry the wiped surfaces.
- Occasionally vacuum the ventilation holes or slots in the back cover of the set.
- Never use thinners, insecticide sprays, or other chemicals on or near the cabinet, as they might cause permanent marring of the cabinet finish.

GLOSSARY OF TELEVISION TERMS



Active Control • Active Control continuously measures and corrects the incoming signals to provide the best picture possible.

Alternate Channel • Allows you to toggle between the last two channels viewed by pressing the A/CH button on the remote control.

Audio/Video Inputs • Jacks (standard RCA), located on the back of the TV, used for external accessory devices. These jacks are designed to receive higher picture resolution and offer sound-connection options.

Auto Programming • When activated, this feature scans for all available channels from regular antenna or cable signals and stores only active broadcast stations in the TV's memory.

Channel Edit • The feature that allows you to add or delete channels from the list of channels stored in the TV's memory.

Closed Captioning • The broadcast standard feature that allows you to read the voice content of television programs on the TV screen. Designed to help the hearing impaired, Closed Captioning shows dialogue and conversations while a TV program is in progress.

Coaxial Cable • A single solid wire normally matched with a metal plug (F-type) end connector that screws (or pushes) directly onto a 75-ohm input found on the television or VCR.

Component Video Inputs • Inputs that allow the separate reception of blue, red, and luminance signals. These inputs provide the highest possible color and picture resolution in the playback of digital signal-source material, such as the kind available from DVD players.

Composite Video Input • An input in which all the components required for displaying the onscreen image are combined in one signal.

High-definition Television (HDTV) • High-resolution digital television.

Incredible Stereo (or Surround) • False acoustic management of the audio signal that produces a dramatic expansion of the wall of sound that surrounds the listener and heightens overall viewing pleasure.

Menu • An onscreen list of feature controls available for you to adjust or set.

Onscreen Displays (OSD) • The wording or messages generated by the television (or VCR) to help you with specific feature controls (color adjustment or programming, for example).

Remote Control Sensor Window • The window or opening found on the television control panel through which infrared remote control command signals are received.

Second Audio Program (SAP) • An additional audio channel provided for in the Multichannel Television Sound (MTS) broadcast standard. A monaural soundtrack included within the recorded or video signal (usually containing a second language translation for the displayed programming).

Status/Exit Button • The remote control function that allows you to quickly confirm what channel number you are watching. Status/Exit can also be used to clear the television of onscreen displays or information. You can use Status/Exit rather than having to wait for the displays to "time out," or automatically disappear from the screen.

S-Video Input • Signal input that allows direct connection of high-resolution video sources, such as a satellite receiver, DVD player, S (Super)-VHS videocassette recorder, or video games. Provides improved picture resolution, sharpness, and clarity.

Tint • TV function that allows you to change the general color balance between cool and warm. Adjust tint according to your personal preference.



INDEX

Active Control™	29	Jack Panel Input/Output Connections Continued	
Alternate Channel Control	45	AV2 Input Jacks	8
Audio Out Control	21	AV3 (Side with Headphone) Input Jacks	9
AutoLock™ Controls		AV4 (Component with VGA) Input Jacks	10
Access Code	31	CVI - Component Video Input Jacks	11
AutoLock™ Status Screen	38	Jack Panel Descriptions	6
Blocking Programs based on Movie Ratings	34	Monitor Output Jacks	13
Blocking Programs based on TV Ratings	35	S-Video Input Jacks	12
Blocking Channels	32	Picture Control	14
Blocking Control (Activating Blocking Controls)	36	Registration of TV Information	2
Blocking based on No Ratings	37	Remote Control Use with Accessory Devices	
Clearing All Blocked Channels	33	Code-Entry Method of Identification	47
Understanding the AutoLock™ Features	30	Direct Access Method of Identification	46
AutoPicture™ Control	43	Direct-Entry Code List	49-50
AutoSound™ Control	44	Search Method of Identification	48
AVL (Automatic Volume Leveler) Control	18	VCR Specific Buttons	51
Balance Control	17	Safety Information	2-3
Bass Control	17	SAP (Secondary Audio Programs) Control	20
Brightness Control	14	Screen Format Control	40
Care and Cleaning Information	52	Sharpness Control	14
Closed Captioning	39	Sleep Timer Control	41
Color Control	14	Stereo/Mono Control	20
Color Temperature (Color Temp) Control	14	Surf (Channel Surf) Control	45
Digital Options (Eye Fidelity™) Control	15	Timer Controls	
Dyn(amic) Contrast Control	16	Activate Control	27
Factory Service Locations	55	Clock, Time Control	23
Feature Highlights	5	Display Control	28
Freeze Control	42	Start Channel Control	26
Glossary of Terms	53	Start Time Control	24
Incr(editable) Surround Control	19	Stop Time Control	25
Index	54	Tint Control	14
Jack Panel Input/Output Connections		Treble Control	17
Audio Output Jacks	13	Troubleshooting	52
Audio/Video Cables	6	TV Speaker Control	22
AV1 Input Jacks	7	Warranty (Limited)	56

FACTORY SERVICE LOCATIONS

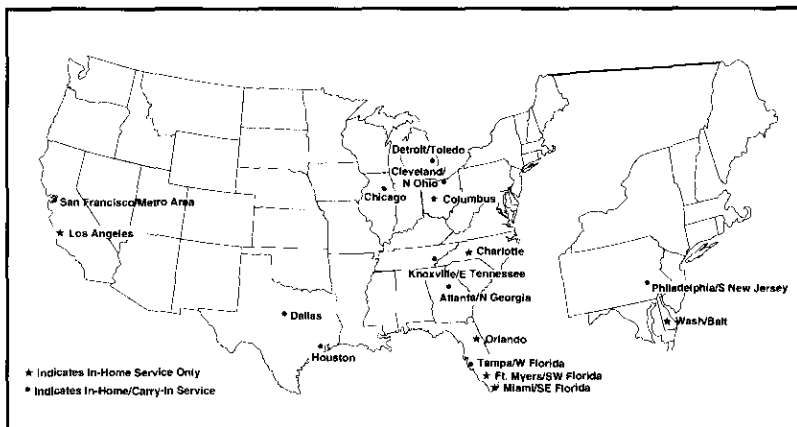

NOTE: If you reside in one of our Philips Factory Service Branch areas (see directory on back), you can contact the nearest Service Branch to obtain efficient and expedient repair for your product. If your product is In-Warranty, you should have proof-of-purchase to ensure No Charge Service. For Out-of-Warranty service, call the location nearest you.

NOTA: Si vous résidez dans une des régions desservies par une succursale de service après vente du fabricant Philips (voir liste ci-dessous), vous pourrez contacter la branche de service après vente la plus près de chez vous pour obtenir un service après vente rapide et efficace. Si le produit est sous garantie, il suffira de présenter une preuve d'achat pour bénéficier d'un service sans frais. Pour les produits non couverts par la garantie, contactez le centre le plus près de chez vous.

NOTA: Si Ud. reside en una de nuestras zonas para sucursales Philips de servicio al de fábrica (ver directorio más abajo), Ud. puede comunicarse con la sucursal de servicio más cercana para obtener una reparación oportuna y eficaz de su producto. Si su producto está todavía bajo garantía, Ud. debe presentar comprobante de compra para no ocasionar ningunos cargos por servicio. Para servicio después del vencimiento de la garantía, llame al lugar más cercano de los abajo indicados.

In Canada: How you can obtain efficient and expedient carry-in, mail-in, or in-home service for your product.

Please contact Philips at:
 1-800-661-6162 (French speaking)
 1-800-363-7278 (English or Spanish speaking)

Au Canada: Comment obtenir le service après-vente pour les produits apportés ou envoyés par la poste à notre centre de service ou le service à domicile. Veuillez contacter philips à:

1-800-661-6162 (Francophone)
 1-800-363-7278 (Anglais ou Espagnol)

En el Canadá: Cómo recibir servicio eficiente para su producto, en persona, por correo o a domicilio.

Favor de comunicarse con Philips at:
 1-800-661-6162 (francófono)
 1-800-363-7278 (Inglés o Español)

QUALITY SERVICE IS AS CLOSE AS YOUR TELEPHONE! SIMPLY LOOK OVER THE LIST BELOW FOR THE NUMBER OF A FACTORY SERVICE CENTER NEAR YOU. YOUR PRODUCT WILL RECEIVE EFFICIENT AND EXPEDIENT CARRY-IN, MAIL-IN, OR IN-HOME SERVICE, AND YOU WILL RECEIVE PEACE OF MIND,

KNOWING YOUR PRODUCT IS BEING GIVEN THE EXPERT ATTENTION OF PHILIPS' FACTORY SERVICE.

COMMENT OBTENIR NOTRE SERVICE APRÈS VENTE RAPIDE ET EFFICACE SOIT PAR COURRIER, À DOMICILE, OU EN SE PRÉSENTANT À UN CENTRE DE SERVICE PHILIPS. PLUS DE 600 CENTRES DE RÉCEPTION DE PRODUITS À RÉPARER À TRAVERS LE PAYS: CONTACTER LE CENTRE DE SERVICE AUX CONSOMMATEURS LE PLUS PROCHE POUR SAVOIR L'EMPLACEMENT DE CES DÉPÔTS DANS UN RAYON DE 50 À 75 MILES (80 KM À 120 KM) DU CENTRE DE SERVICE LOCAL.

CÓMO OBTENER UN SERVICIO OPORTUNO Y EFICIENTE POR CORREO, EN CASA O EN PERSONA PARA SU PRODUCTO A TRAVÉS DE UN CENTRO PHILIPS DE SERVICIO. MAS DE 600 SITIOS POR TODO EL PAIS PARA LA RECEPCION DE PRODUCTOS NECESITADOS DE REPARACIONES: COMUNICARSE CON EL CENTRO DE SERVICIO DE FABRICA MAS CERCANO PARA ESTOS LUGARES DENTRO DE UN RADIO DE 80 A 120 KM (50 A 75 MILLAS) DEL CENTRO DE SERVICIO LOCAL.

ATLANTA

Philips Factory Service
 550 Franklin Road., Suite F
 Marietta, GA 30067
 800-273-1501

TAMPA

Philips Factory Service
 1911 US Highway 301 North
 Tampa, FL 33619
 800-442-2027

SAN FRANCISCO

Philips Factory Service
 681 East Brokaw Rd.
 San Jose, CA 95112
 800-300-9013

HOUSTON

Philips Factory Service
 1110 N. Post Oak Rd., Suite
 100
 Houston, TX 77055
 800-952-3254

CLEVELAND

Philips Factory Service
 950 Keynote Circle
 Brooklyn Heights, OH 44131
 800-331-7037

DETROIT

Philips Factory Service
 25173 Dequindre
 Madison Heights, MI 48071
 800-438-1398

DALLAS

Philips Factory Service
 415 N. Main Street, #107
 Euless, TX 76040
 800-952-3254

CHICAGO

Philips Factory Service
 1279 W. Hamilton Pkwy.
 Itasca, IL 60143
 800-531-2922

KNOXVILLE

Philips Factory Service
 6700 D Papermill Rd.
 Knoxville, TN 37919
 800-821-1767

PHILADELPHIA

Philips Factory Service
 352 Dunks Ferry Rd.
 Bensalem, PA 19020
 800-847-9320

LIMITED WARRANTY

COLOR TELEVISION

90 Days Free Labor

One Year Free Replacement of Parts (Two Years Free Replacement on Color Picture Tube)

This product can be repaired in-home.

WHO IS COVERED?

You must have proof of purchase to receive warranty service. A sales receipt or other document showing that you purchased the product is considered proof of purchase.

WHAT IS COVERED?

Warranty coverage begins the day you buy your product. For 90 days thereafter, all parts will be repaired or replaced free, and labor is free. From 90 days to one year from the day of purchase, all parts will be repaired or replaced free, but you pay for all labor charges. From one to two years from the day of purchase, you pay for the replacement or repair of all parts except the picture tube, and for all labor charges. After two years from the day of purchase, you pay for the replacement or repair of all parts, and for all labor charges.

All parts, including repaired and replaced parts, are covered only for the original warranty period. When the warranty on the product expires, the warranty on all replaced and repaired parts also expires.

WHAT IS EXCLUDED?

Your warranty does not cover:

- labor charges for installation or setup of the product, adjustment of customer controls on the product, and installation or repair of antenna systems outside of the product.
- product repair and/or part replacement because of misuse, accident, unauthorized repair or other cause not within the control of Philips Consumer Electronics Company.
- reception problems caused by signal conditions or cable or antenna systems outside the unit.
- a product that requires modification or adaptation to enable it to operate in any country other than the country for which it was designed, manufactured, approved and/or authorized, or repair of products damaged by these modifications.
- incidental or consequential damages resulting from the product. (Some states do not allow the exclusion of incidental or consequential damages, so the above exclusion may not apply to you. This includes, but is not limited to, prerecorded material, whether copyrighted or not copyrighted.)
- a product used for commercial or institutional purposes.

WHERE IS SERVICE AVAILABLE?

Warranty service is available in all countries where the product is officially distributed by Philips Consumer Electronics Company. In countries where Philips Consumer Electronics Company does not distribute the product, the local Philips service organization will attempt to provide service (although there may be a delay if the appropriate spare parts and technical manual(s) are not readily available).

MAKE SURE YOU KEEP...

Please keep your sales receipt or other document showing proof of purchase. Attach it to this owner's manual and keep both nearby. Also keep the original box and packing material in case you need to return your product.

BEFORE REQUESTING SERVICE...

Please check your owner's manual before requesting service. Adjustments of the controls discussed there may save you a service call.

TO GET WARRANTY SERVICE IN U.S.A., PUERTO RICO OR U.S. VIRGIN ISLANDS...

Contact a Philips factory service center (see enclosed list) or authorized service center to arrange repair.

(In U.S.A., Puerto Rico and U.S. Virgin Islands, all implied warranties, including implied warranties of merchantability and fitness for a particular purpose, are limited in duration to the duration of this express warranty. But, because some states do not allow limitations on how long an implied warranty may last, this limitation may not apply to you.)

FOR WARRANTY COVERAGE IN CANADA...

Note: Product Warranty coverage may vary between countries where product is distributed by Philips Consumer Electronics Company. In order to receive full and specific warranty details for products sold and serviced in Canada, please contact Philips at:

1-800-661-6162 (from Canada - French Speaking)

1-800-531-0039 (English and Spanish Speaking)

REMEMBER...

Please record the model and serial numbers found on the product below. Also, please fill out and mail your warranty registration card promptly. It will be easier for us to notify you if necessary.

MODEL # _____

SERIAL # _____

This warranty gives you specific legal rights. You may have other rights which vary from state/province to state/province.

Philips Consumer Electronics Company, P.O. Box 520890, Miami, FL 33152, (402) 536-4171