

PRO-FORM® 365e CrossWalk

Model No. DTL3495.0

Serial No. _____

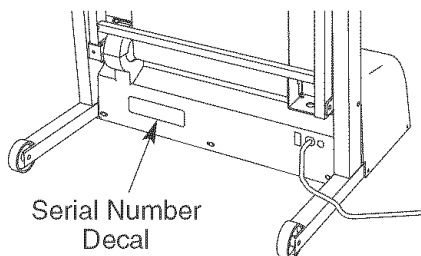

QUESTIONS?

As a manufacturer, we are committed to providing complete customer satisfaction. If you have questions, or if parts are damaged or missing, PLEASE CONTACT OUR CUSTOMER SERVICE DEPARTMENT DIRECTLY.

CALL TOLL-FREE:

1-888-533-1333

Mon.–Fri., 6 a.m.–6 p.m. MST

ON THE WEB:

www.proformservice.com

USER'S MANUAL

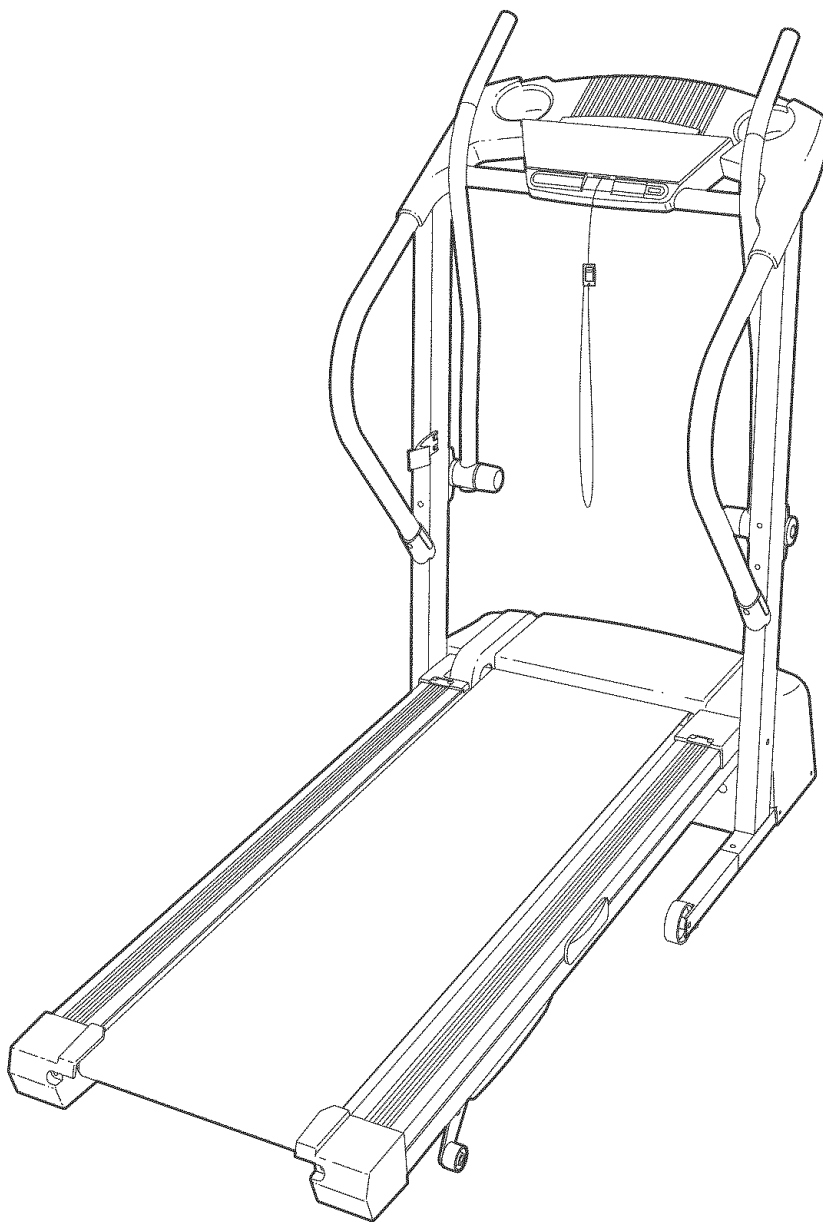

CAUTION

Read all precautions and instructions in this manual before using this equipment. Save this manual for future reference.



Visit our website at

www.proform.com

new products, prizes,
fitness tips, and much more!

PRO-FORM® 365e **CrossWalk**

TABLE OF CONTENTS

IMPORTANT PRECAUTIONS	3
BEFORE YOU BEGIN	5
ASSEMBLY	6
OPERATION AND ADJUSTMENT	10
HOW TO FOLD AND MOVE THE TREADMILL	14
TROUBLESHOOTING	16
CONDITIONING GUIDELINES	18
ORDERING REPLACEMENT PARTSBack Cover
LIMITED WARRANTYBack Cover

Note: An EXPLODED DRAWING and a PART LIST are attached in the center of this manual.

IMPORTANT PRECAUTIONS

▲ WARNING: To reduce the risk of burns, fire, electric shock, or injury to persons, read the following important precautions and information before operating the treadmill.

1. It is the responsibility of the owner to ensure that all users of this treadmill are adequately informed of all warnings and precautions.
2. Use the treadmill only as described.
3. Place the treadmill on a level surface, with at least eight feet of clearance behind it and two feet on each side. Do not place the treadmill on any surface that blocks air openings. To protect the floor or carpet from damage, place a mat under the treadmill.
4. Keep the treadmill indoors, away from moisture and dust. Do not put the treadmill in a garage or covered patio, or near water.
5. Do not operate the treadmill where aerosol products are used or where oxygen is being administered.
6. Keep children under the age of 12 and pets away from the treadmill at all times.
7. The treadmill should be used only by persons weighing 250 pounds or less.
8. Never allow more than one person on the treadmill at a time.
9. Wear appropriate exercise clothes when using the treadmill. Do not wear loose clothes that could become caught in the treadmill. Athletic support clothes are recommended for both men and women. *Always wear athletic shoes. Never use the treadmill with bare feet, wearing only stockings, or in sandals.*
10. When connecting the power cord (see page 10), plug the power cord into a surge suppressor (not included) and plug the surge suppressor into a grounded circuit capable of carrying 15 or more amps. No other appliance should be on the same circuit. Do not use an extension cord.
11. Use only a single-outlet surge suppressor that meets all of the specifications described on page 10. To purchase a surge suppressor, see your local PROFORM dealer or call the toll-free telephone number on the front cover of this manual and order part number 146148, or see your local electronics store.
12. Failure to use a properly functioning surge suppressor could result in damage to the control system of the treadmill. If the control system is damaged, the walking belt may change speed, accelerate, or stop unexpectedly, which may result in a fall and serious injury.
13. Keep the power cord and the surge suppressor away from heated surfaces.
14. Never move the walking belt while the power is turned off. Do not operate the treadmill if the power cord or plug is damaged, or if the treadmill is not working properly. (See BEFORE YOU BEGIN on page 5 if the treadmill is not working properly.)
15. Never start the treadmill while you are standing on the walking belt. Always hold the handrails while using the treadmill.
16. The treadmill is capable of high speeds. Adjust the speed in small increments to avoid sudden jumps in speed.
17. The pulse sensor is not a medical device. Various factors, including your movement, may affect the accuracy of heart rate readings. The sensor is intended only as an exercise aid in determining heart rate trends in general.
18. Do not use the hand weights at speeds faster than walking speeds. Using weights and not holding the handrails may compromise your ability to maintain your balance. Exercises using weights should be attempted only by experienced users.
19. Never leave the treadmill unattended while it is running. Always remove the key and unplug the power cord when the treadmill is not in use.
20. Do not attempt to raise, lower, or move the treadmill until it is properly assembled. (See ASSEMBLY on page 6, and HOW TO FOLD AND MOVE THE TREADMILL on page 14.) You must be able to safely lift 45 pounds (20 kg) to raise, lower, or move the treadmill.

21. When folding or moving the treadmill, make sure that the storage latch is fully closed.

22. Inspect and properly tighten all parts of the treadmill regularly.

23. Never insert any object into any opening.

24. **DANGER:** Always unplug the power cord immediately after use, before cleaning the treadmill, and before performing the

maintenance and adjustment procedures described in this manual. Never remove the motor hood unless instructed to do so by an authorized service representative. Servicing other than the procedures in this manual should be performed by an authorized service representative only.

25. This treadmill is intended for in-home use only. Do not use this treadmill in a commercial, rental, or institutional setting.

⚠ WARNING: Before beginning this or any exercise program, consult your physician. This is especially important for persons over the age of 35 or persons with pre-existing health problems. Read all instructions before using. ICON assumes no responsibility for personal injury or property damage sustained by or through the use of this product.

SAVE THESE INSTRUCTIONS

The decals shown here have been placed on your treadmill. If a decal is missing, or if it is not legible, please call the toll-free telephone number on the front cover of this manual and order a free replacement decal. Apply the decal in the location shown. Note: The decals are not shown at actual size.

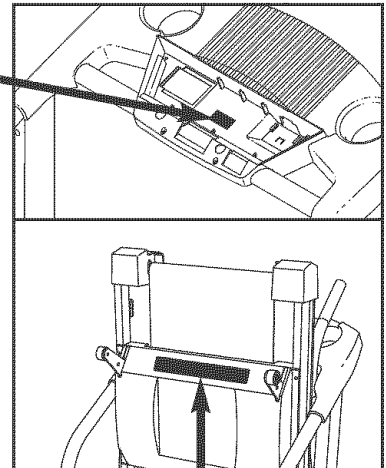
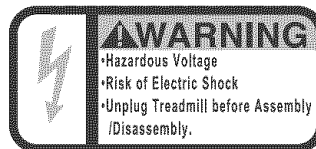

⚠ WARNING: Protect yourself and others from risk of serious injury. Read the user's manual and:

- Fully engage storage latch before treadmill is moved or stored.
- Reduce incline to lowest level before folding treadmill into storage position.



- Stand only on side rails when starting or stopping treadmill.
- Change speed in small increments.
- Hold handrails to prevent falling, and always wear the safety clip while operating treadmill.
- Stop if you feel faint, dizzy, or short of breath.



- Never allow children on or around treadmill.
- Remove key when not in use.



- Keep clothing, fingers, and hair away from moving belt.
- Never try to adjust or fix the belt while it is moving.
- Always wear athletic shoes while operating treadmill.

BEFORE YOU BEGIN

Thank you for selecting the new PROFORM® CROSSWALK 365e treadmill. The CROSSWALK 365e treadmill combines advanced technology with innovative design to help you get the most from your exercise in the convenience of your home. And when you're not exercising, the CROSSWALK 365e treadmill can be folded up, requiring less than half the floor space of other treadmills.

For your benefit, read this manual carefully before using the treadmill. If you have questions after reading this manual, see the front cover of this manual. To help us assist you, please note the product model

number and serial number before calling. The model number of the treadmill is DTL3495.0. The serial number can be found on a decal attached to the treadmill (see the front cover of this manual for the location).

To avoid a registration fee for any service needed under warranty, you must register the treadmill at www.proformservice.com/registration.

Before reading further, please review the drawing below and familiarize yourself with the labeled parts.

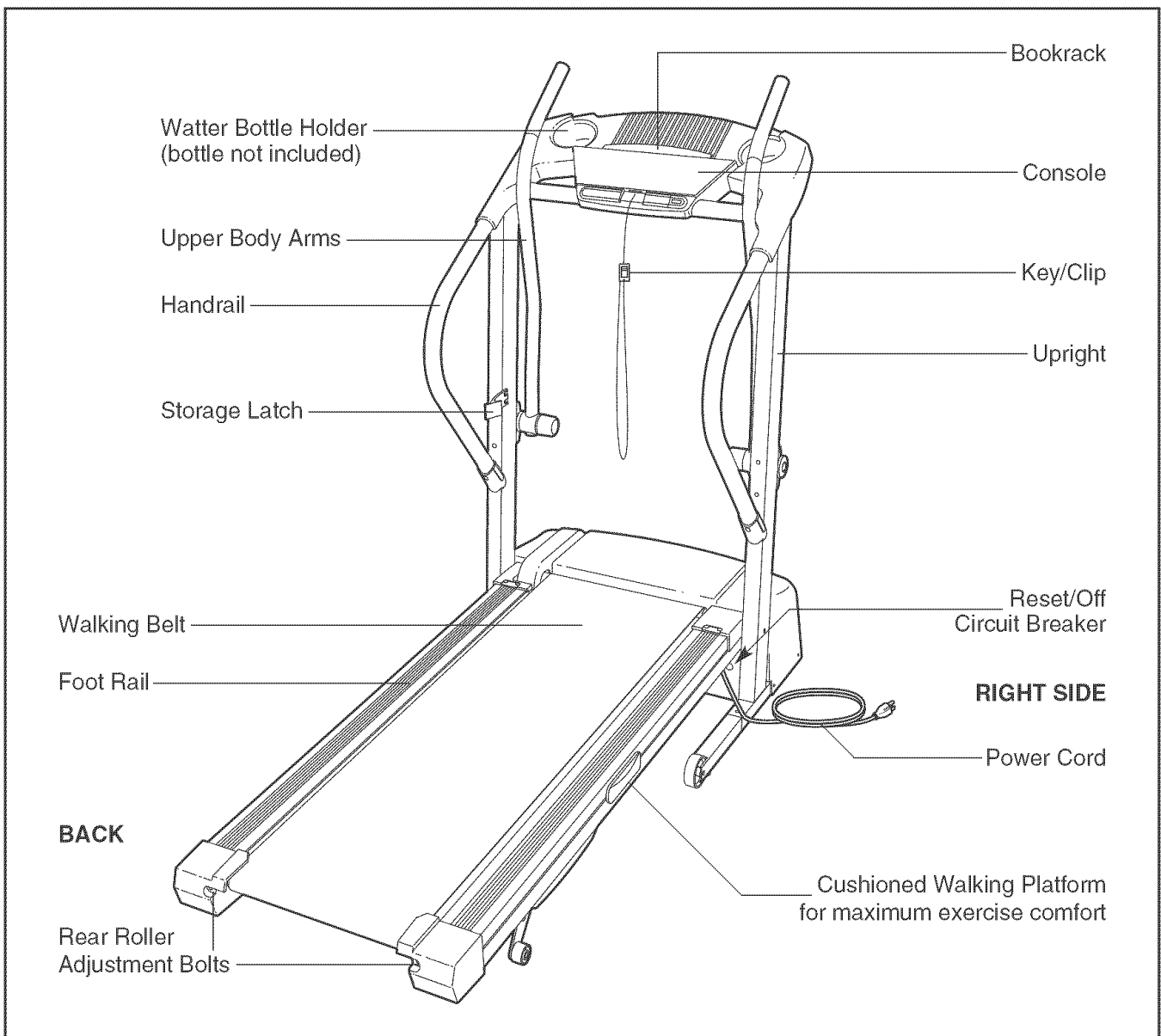

ASSEMBLY

To hire an authorized service technician to assemble the treadmill, call toll-free 1-800-445-2480.

Assembly requires two persons. Set the treadmill in a cleared area and remove all packing materials. Do not dispose of the packing materials until assembly is completed.

Note: The underside of the treadmill walking belt is coated with high-performance lubricant. During shipping, a small amount of lubricant may be transferred to the top of the walking belt or the shipping carton. This is a normal condition and does not affect treadmill performance. If there is lubricant on top of the walking belt, simply wipe off the lubricant with a soft cloth and a mild, non-abrasive cleaner.

Assembly requires the included allen wrenches  and your own phillips screwdriver , and rubber mallet .

For help identifying the assembly hardware, see the drawings below. If a part is not in the parts bag, first check to see if it has been pre-assembled.

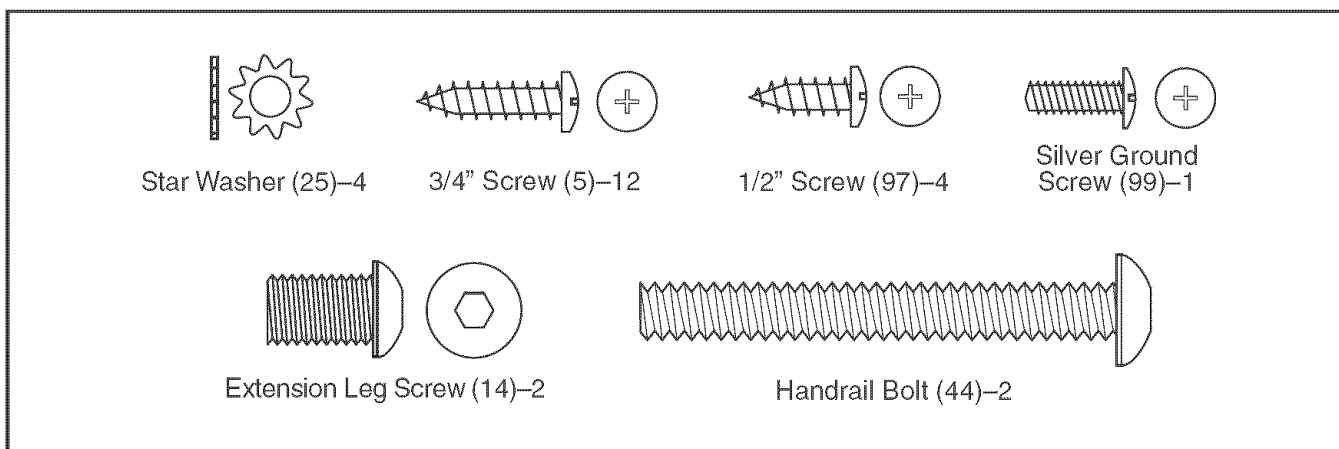

1. With the help of a second person, raise the Uprights (38) to the position shown.

Next, insert one of the Extension Legs (15) into the treadmill as shown; make sure that the Extension Leg is turned so the Base Pad (33) is underneath it. Note: It may be helpful to tip the Uprights (38) in the direction shown by the arrow as you insert the Extension Leg.

Attach the Extension Leg (15) with an Extension Leg Screw (14). **Make sure to push on the head of the Extension Leg Screw while tightening it.**

Attach the other Extension Leg (not shown) in the same way.

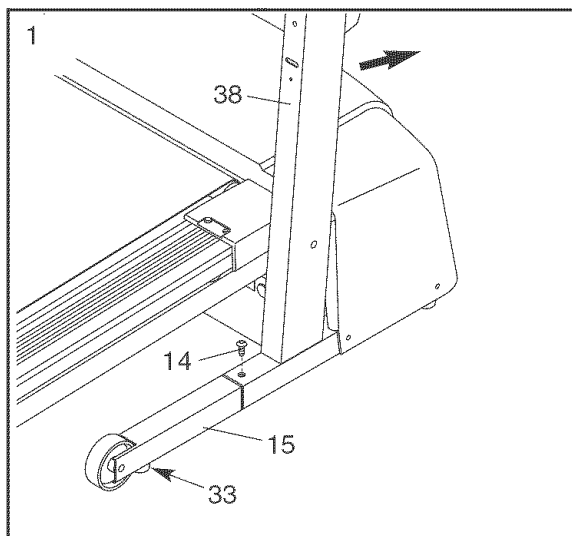

2. Insert the tab on one of the Handrail Brackets (17) into the slot in the right Upright (38). Attach the Handrail Bracket with a 3/4" Screw (5) and a Star Washer (25). **Attach the other Handrail Bracket to the left Upright (not shown) in the same way.**

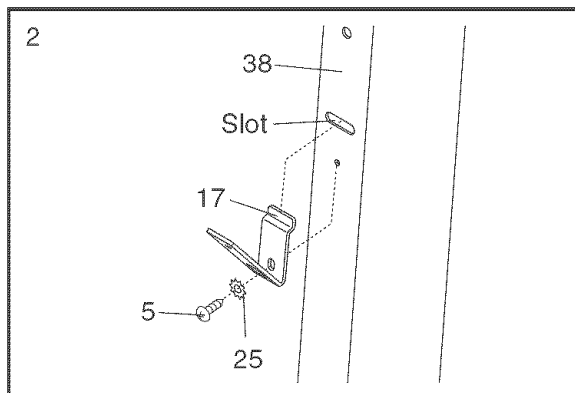

3. Identify the Right Handrail (16), which has a large hole in the left side. Feed the Upright Wire (53) into the hole in the bottom of the Right Handrail and out of the large hole in the side. Note: It may be helpful to use needlenose pliers to pull the Wire Harness out of the hole.

Press a Handrail Cap (103) onto the lower end of the Right Handrail (16) as shown. Set the Right Handrail on the right Upright (38), while sliding the lower end of the Right Handrail onto the Handrail Bracket (17). Attach the Right Handrail with an Upright Bolt (44) in the upper end and a 3/4" Screw (5) and a Star Washer (25) in the lower end.

Attach the Left Handrail (4) in the same way. Note: There is not a wire harness on the left side.

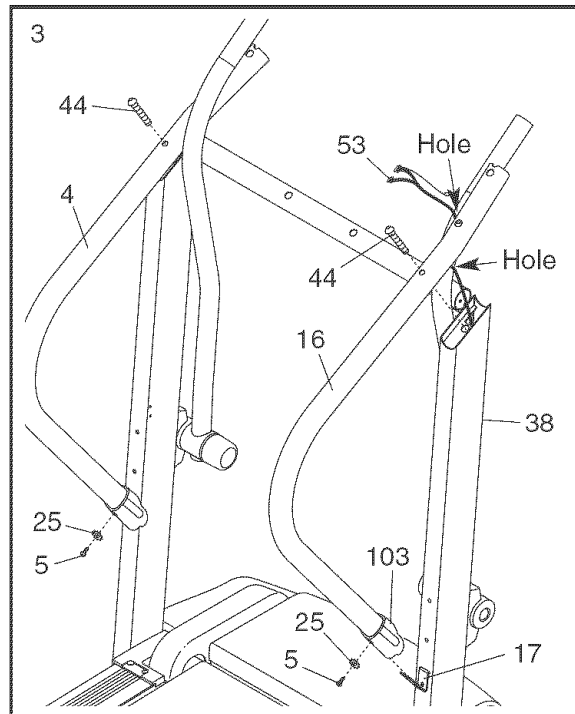

4. Attach the ground wire to the small hole in the side of the Right Handrail (16) with a Silver Ground Screw (99).

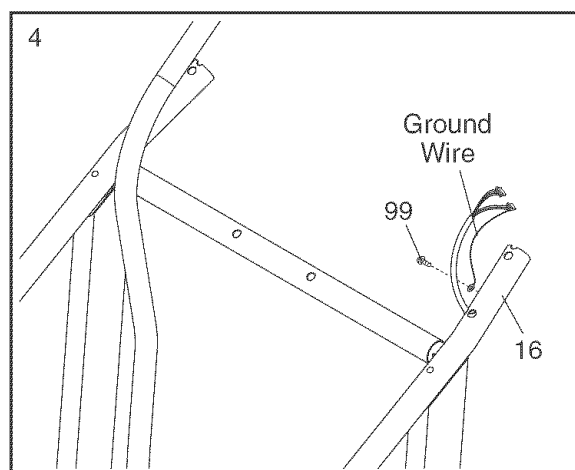

- Loosen the two (one shown) Crossbar Screws (98) several turns. Place the Console Base (87) on the Right Handrail (16) and the Left Handrail (not shown). **Make sure that the Wire Harness is not pinched in the Right Handrail.** Attach the Console Base with four 3/4" Screws (5) (only two Screws are shown). **Start all four 3/4" Screws before tightening them.**

Insert the Wire Harness (53) through the two indicated plastic ties on the Console Base (87). Next, insert the Wire Harness up through the opening beside the Wire Cover (10). Make sure that the Wire Cover is securely attached to the Console Base.

See the inset drawing. Look at the top of the Console Base (87). Insert the Wire Harness (53) through the plastic tie on top of the Console Base.

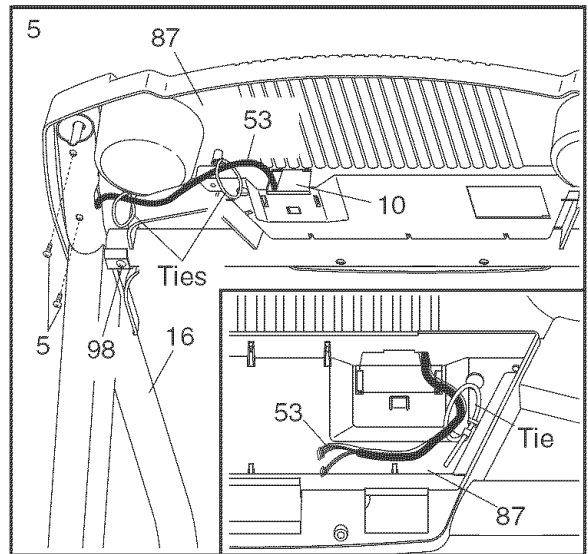

- Hold the Console (10) near the Console Base (87). **Touch the Right Handrail (16) to discharge any static.** See the inset drawing. Find the 2-wire connector on the end of the Wire Harness (53). Insert the connector into the red connector beneath the Console. **The connectors should slide together easily and snap into place.** If they do not, turn the connector and then insert it. Insert the 6-wire connector into the socket beneath the Console the same way.

Insert the excess Wire Harness (53) down through the opening in the Console Base (87) [see the inset drawing in step 5)]. **Securely tighten the plastic tie on top of the Console Base to prevent the Wire Harness from slipping.** Then, cut off the end of the plastic tie.

Make sure that the connectors and wires appear as shown at the right. **IF THE CONNECTORS ARE NOT INSERTED PROPERLY, THE CONSOLE MAY BE DAMAGED WHEN THE POWER IS TURNED ON.**

See drawing 6a. Press the Bookrack (85) onto the Console Base (87) in the location shown.

Set the Console (10) on the Console Base (87). Insert the excess Wire Harness (53) into the large hole in the side of the Right Handrail (16). **Securely tighten the plastic ties on the bottom of the Console Base to prevent the Wire Harness from slipping.** Then, cut off the ends of the plastic ties.

Attach the Console (10) to the Console Base (87) with two 3/4" Screws (5) and four 1/2" Screws (97). **Start all six Screws before tightening them; do not overtighten the Screws.** Tighten the two Crossbar Screws (98) (only one is shown).

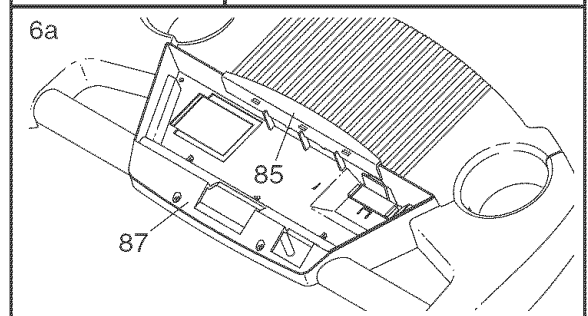
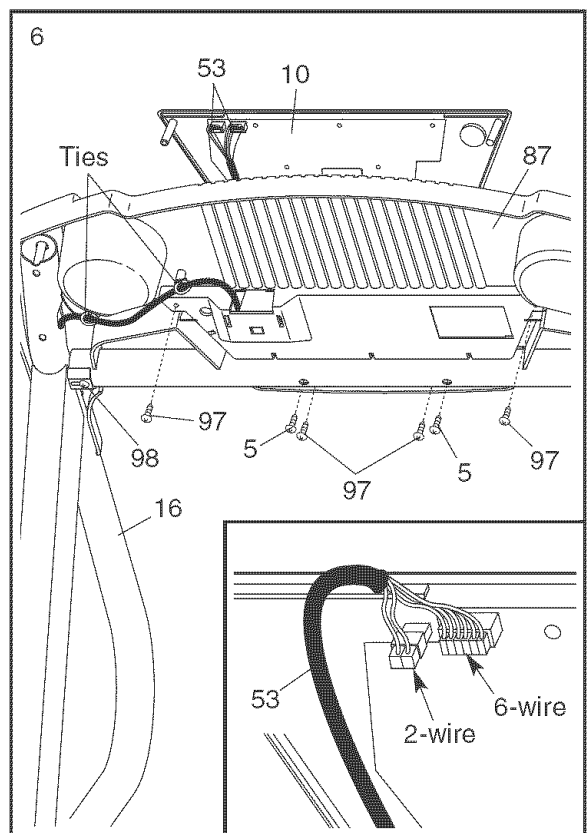

7. Attach the Storage Latch (66) to the left Upright (38) with two 3/4" Screws (5) as shown. **Do not overtighten the Screws.**

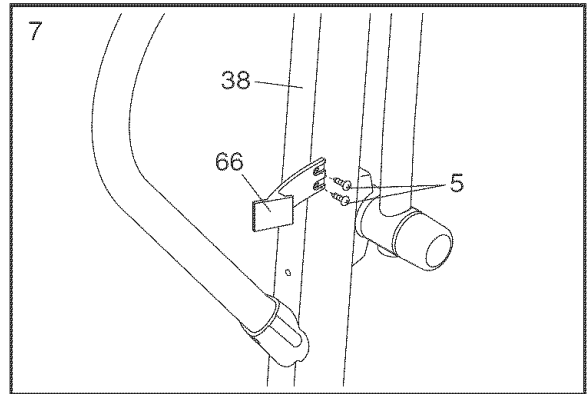

8. **Make sure that all parts are properly tightened before you use the treadmill.** Note: Extra hardware may be included. Keep the included allen wrenches in a secure place. The large allen wrench is used to adjust the walking belt (see page 17). To protect the floor or carpet, place a mat under the treadmill.

OPERATION AND ADJUSTMENT

THE PRE-LUBRICATED WALKING BELT

Your treadmill features a walking belt coated with high-performance lubricant. **IMPORTANT: Never apply silicone spray or other substances to the walking belt or the walking platform.** Such substances will deteriorate the walking belt and cause excessive wear.

HOW TO PLUG IN THE POWER CORD

⚠ DANGER: Improper connection of the equipment-grounding conductor can result in an increased risk of electric shock. Check with a qualified electrician or serviceman if you are in doubt as to whether the product is properly grounded. Do not modify the plug provided with the product—if it will not fit the outlet, have a proper outlet installed by a qualified electrician.

Your treadmill, like any other type of sophisticated electronic equipment, can be seriously damaged by sudden voltage changes in your home's power. Voltage surges, spikes, and noise interference can result from weather conditions or from other appliances being turned on or off. **To decrease the possibility of your treadmill being damaged, always use a surge suppressor with your treadmill (see drawing 1 at the right).** To purchase a surge suppressor, see your local PROFORM dealer or call the toll-free telephone number on the front cover of this manual and order part number 146148, or see your local electronics store.

Use only a single-outlet surge suppressor that is UL 1449 listed as a transient voltage surge suppressor (TVSS). The surge suppressor must have a UL suppressed voltage rating of 400 volts or less and a minimum surge dissipation of 450 joules. The surge suppressor must be electrically rated for 120 volts AC and 15 amps. There must be a monitoring light on the surge suppressor to indicate whether it is functioning properly. Failure to use a properly functioning surge suppressor could result in damage to the control system of the treadmill. If the control system is damaged, the walking belt may change speed, accelerate or stop unexpectedly, which may result in a fall and serious injury.

This product must be grounded. If it should malfunction or break down, grounding provides a path of least resistance for electric current to reduce the risk of elec-

tric shock. This product is equipped with a cord having an equipment-grounding conductor and a grounding plug. **Plug the power cord into a surge suppressor, and plug the surge suppressor into an appropriate outlet that is properly installed and grounded in accordance with all local codes and ordinances. Important: The treadmill is not compatible with GFCI-equipped outlets.**

This product is for use on a nominal 120-volt circuit, and has a grounding plug that looks like the plug illustrated in drawing 1 below. A temporary adapter that looks like the adapter illustrated in drawing 2 may be used to connect the surge suppressor to a 2-pole receptacle as shown in drawing 2 if a properly grounded outlet is not available.

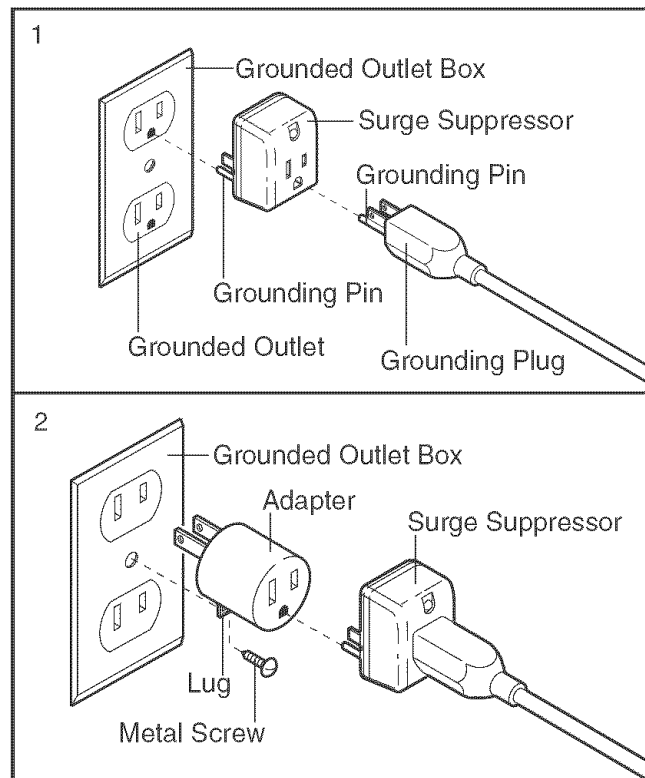

The temporary adapter should be used only until a properly grounded outlet (drawing 1) can be installed by a qualified electrician.

The green-colored rigid ear, lug, or the like extending from the adapter must be connected to a permanent ground such as a properly grounded outlet box cover. Whenever the adapter is used it must be held in place by a metal screw. **Some 2-pole receptacle outlet box covers are not grounded. Contact a qualified electrician to determine if the outlet box cover is grounded before using an adapter.**

CONSOLE DIAGRAM

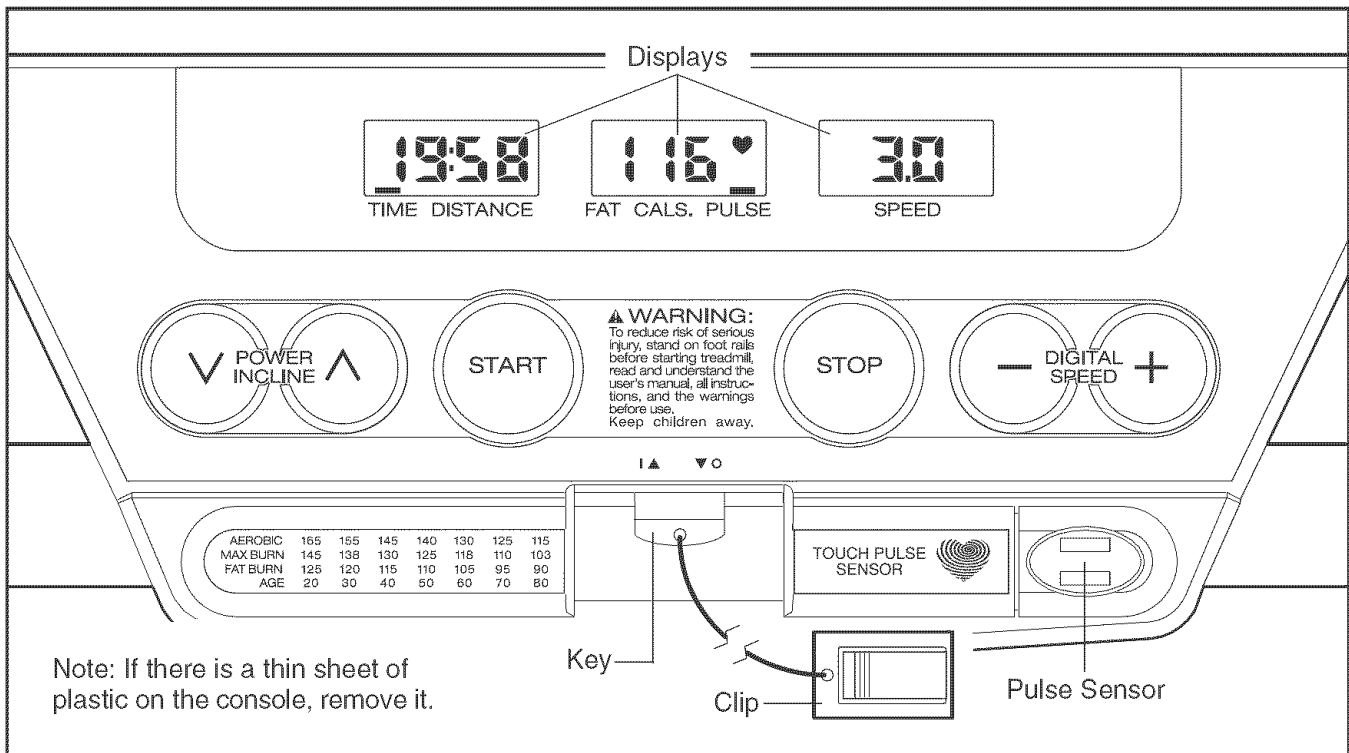

CAUTION: Before operating the console, read the following precautions.

- Do not stand on the walking belt when turning on the power.
- Always wear the clip (see the drawing above) while operating the treadmill.
- Adjust the speed in small increments to avoid sudden jumps in speed.
- To reduce the possibility of electric shock, keep the console dry. Avoid spilling liquids on the console and place only a sealed water bottle in the accessory trays.

Stand on the foot rails of the treadmill. Find the clip attached to the key (see the drawing above), and slide the clip onto the waistband of your clothes. Next, insert the key into the console. A tone will sound and the three displays will light. **Test the clip by carefully taking a few steps backward until the key is pulled from the console. If the key is not pulled from the console, adjust the position of the clip.**

Follow the steps below to operate the console.

- 1** Insert the key into the console.
When the key is inserted, a tone will sound and the three displays will light.
- 2** Press the Start button or the Speed + button to start the walking belt.

A moment after the button is pressed, the walking belt will begin to move. Hold the handrails and begin walking.

As you exercise, change the speed of the walking belt as desired by pressing the Speed buttons. Each time a button is pressed, the speed setting will change by 0.1 mph; if a button is held down, the speed setting will change in increments of 0.5 mph. **Note: The console can display speed and distance in either miles or kilometers (see SPEED DISPLAY on page 12). For simplicity, all instructions in this section refer to miles.**

STEP-BY-STEP CONSOLE OPERATION

Before operating the console, make sure that the power cord is properly plugged in (see page 10).

Next, make sure that the reset/off circuit breaker, located on the treadmill frame near the power cord, is in the reset position.

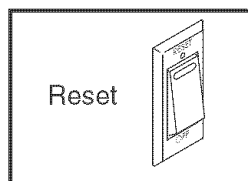

Note: To prevent damage to the walking platform, always wear clean shoes when using the treadmill.

To stop the walking belt, press the Stop button. The elapsed time will begin to flash in the Time/Distance display.

Note: During the first few minutes that the treadmill is used, inspect the alignment of the walking belt, and align it if necessary (see page 17).

3 Change the incline of the treadmill as desired.

To change the incline of the treadmill, press either of the Incline buttons until the desired incline level is reached.

4 Follow your progress with the three displays.

Time/Distance

display—This display shows the elapsed time and the distance that you have walked or run. The display will change from one number to the other every few seconds, as shown by the mode indicators. When the Stop button is pressed, the elapsed time will flash.

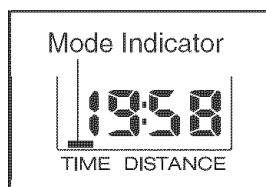

**Fat Calories/Calories/
Pulse display**—This display shows the approximate numbers of *fat calories* and *calories* you have burned (see FAT BURNING on page 18). The display will change from one number to the other every few seconds, as shown by the mode indicators. The display will also show your heart rate when you use the pulse sensor (see step 5).

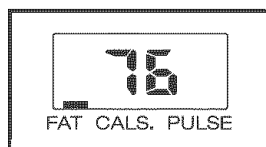

Speed display—This display shows the speed of the walking belt



Note: The console can display speed and distance in either miles or kilometers. To change the unit of measurement,

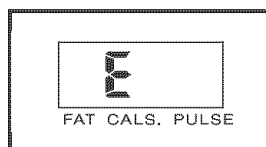

hold down the Stop button, insert the key into the console, and continue to hold the Stop button for a moment. An "E" for English miles or an "M" for metric kilometers will appear in the Fat Calories/Calories/Pulse display. Press the Speed increase button to change the unit of measurement. When the desired unit of measurement is selected, remove the key and then reinsert it.

To reset the displays, press the Stop button, remove the key, and then reinsert the key.

5 Measure your heart rate if desired.

To measure your heart rate, stand on the foot rails and place your thumb on the pulse sensor. **Do not press too hard, or the circulation in your**

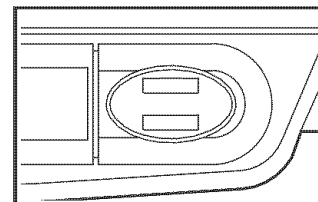

thumb will be restricted and your pulse will not be detected. After a few seconds, the heart-shaped indicator in the Fat Calories/Calories/Pulse display will begin to flash, one or two dashes (—) will appear, and then your heart rate will be shown. Hold your thumb on the pulse sensor for about 15 seconds for the most accurate reading.

If the displayed heart rate appears to be too high or too low, or if your heart rate is not displayed, lift your thumb off the pulse sensor for a few seconds. Then, place your thumb on the pulse sensor as described above. Remember to stand still while measuring your heart rate.

6 When you are finished exercising, remove the key.

Step onto the foot rails, press the Stop button, and remove the key from the console. Keep the key in a secure place.

HOW TO USE THE UPPER BODY ARMS

As you walk on the treadmill, you can either hold the handrails or use the upper body arms. To exercise your arms, shoulders, and back for a total body workout, move the upper body arms forward and back as you walk on the treadmill.

To vary the intensity of your upper body exercise, the resistance of the upper body arms can be adjusted. To increase the resistance, turn the resistance knobs clockwise; to decrease the resistance, turn the knobs counterclockwise.

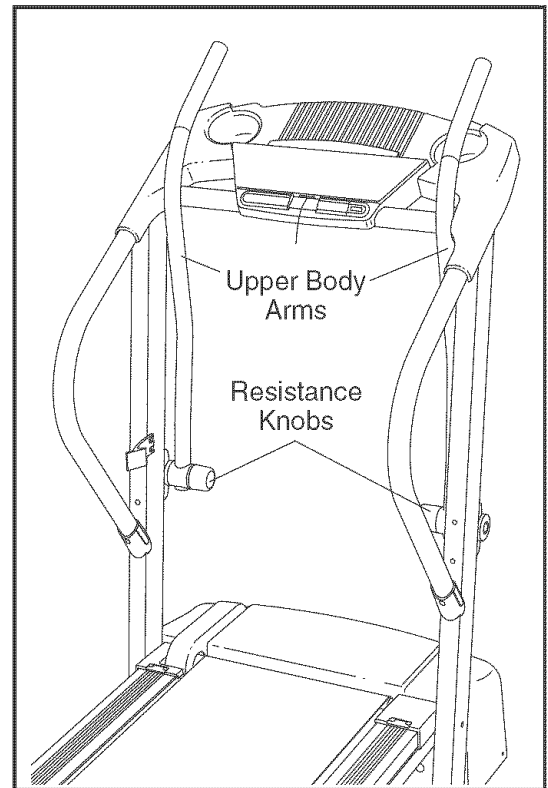

HOW TO FOLD AND MOVE THE TREADMILL

HOW TO FOLD THE TREADMILL FOR STORAGE

Before folding the treadmill, adjust the incline to the lowest position. If this is not done, the treadmill may become damaged. Next, unplug the power cord. **CAUTION:** You must be able to safely lift 45 pounds (20 kg) to raise, lower, or move the treadmill.

1. Hold the treadmill with your hands in the locations shown by the arrow at the right. **To decrease the possibility of injury, bend your legs and keep your back straight. As you raise the treadmill, make sure to lift with your legs rather than your back.** Raise the treadmill about halfway to the vertical position.

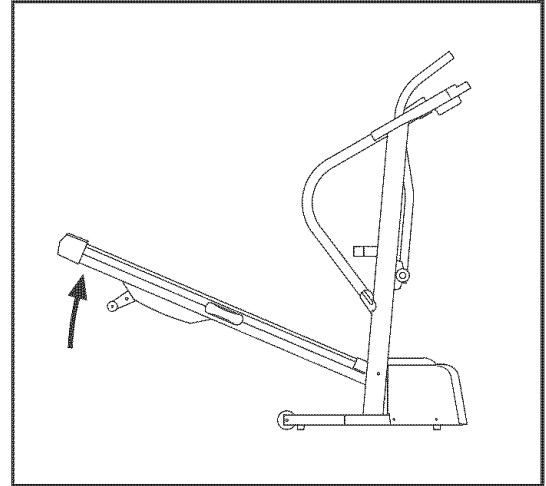

2. Move your right hand to the position shown and hold the treadmill firmly. Using your left thumb, press the storage latch to the left. Raise the treadmill until the storage latch closes over the catch. **Make sure that the storage latch is fully engaged over the catch.**

To protect the floor or carpet from damage, place a mat under the treadmill. Keep the treadmill out of direct sunlight. Do not leave the treadmill in the storage position in temperatures above 85° Fahrenheit.

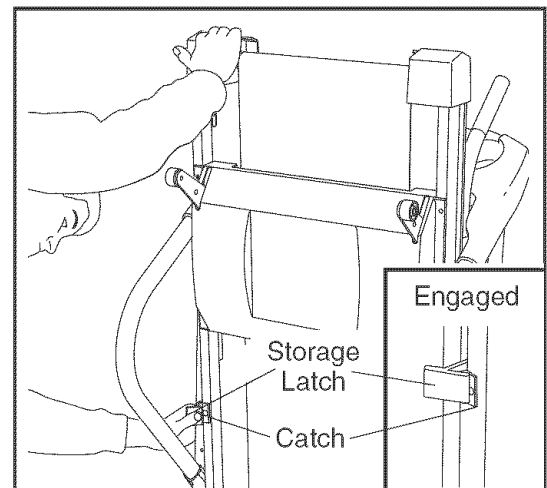

HOW TO MOVE THE TREADMILL

Before moving the treadmill, convert the treadmill to the storage position as described above. **Make sure that the frame is securely held by the storage latch.**

1. Hold the upper ends of the handrails. Place one foot on the base as shown.
2. Tilt the treadmill back until it rolls freely on the front wheels. Carefully move the treadmill to the desired location. **To reduce the risk of injury, use extreme caution while moving the treadmill. Do not move the treadmill over an uneven surface.**
3. Place one foot on the base, and carefully lower the treadmill until it is resting in the storage position.

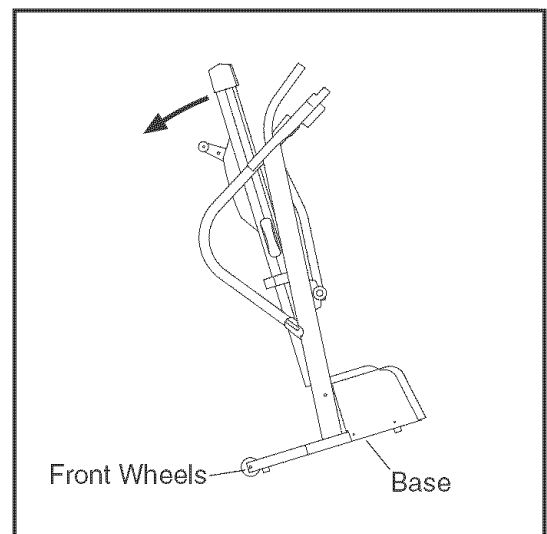

HOW TO LOWER THE TREADMILL FOR USE

1. Hold the upper end of the treadmill with your right hand. Press the storage latch to the left. Pivot the treadmill down until the frame and the foot rail are past the storage latch.

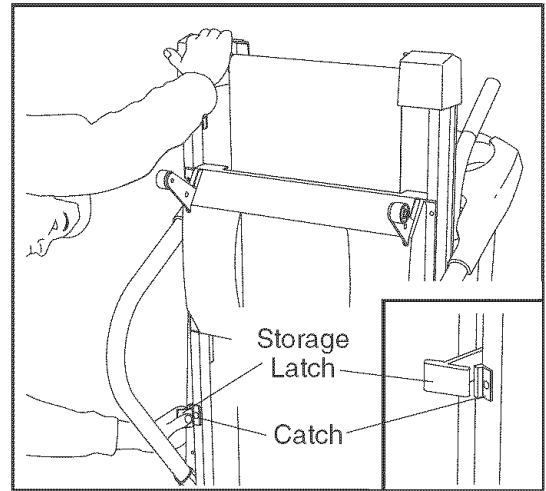

2. Hold the treadmill firmly with both hands, and lower the treadmill to the floor. **Do not drop the treadmill frame to the floor. To decrease the possibility of injury, bend your legs and keep your back straight.**

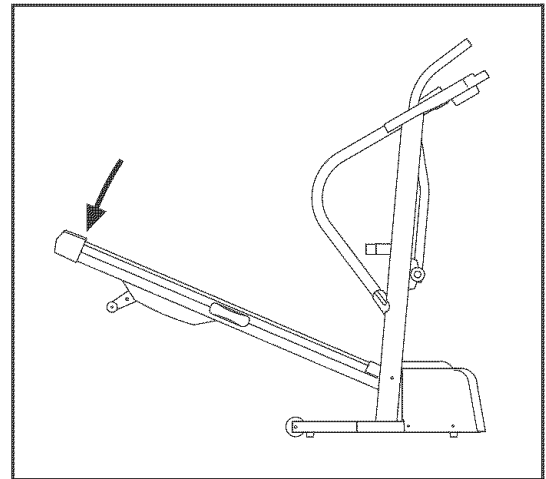

TROUBLESHOOTING

Most treadmill problems can be solved by following the steps below. Find the symptom that applies, and follow the steps listed. If further assistance is needed, please call the toll-free telephone number on the front cover of this manual.

PROBLEM: The power does not turn on

SOLUTION: a. Make sure that the power cord is plugged into a surge suppressor, and that the surge suppressor is plugged into a properly grounded outlet (see page 10). Use only a single-outlet surge suppressor that meets all of the specifications described on page 10. Important: The treadmill is not compatible with GFCI-equipped outlets.

b. After the power cord has been plugged in, make sure that the key is fully inserted into the console.

c. Check the reset/off circuit breaker located on the treadmill frame near the power cord. If the switch protrudes as shown, the circuit breaker has tripped. To reset the circuit breaker, wait for five minutes and then press the switch back in.

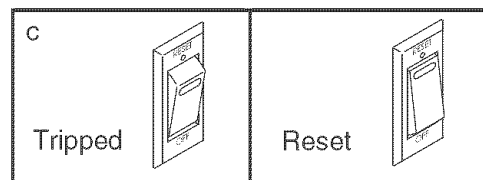

PROBLEM: The power turns off during use

SOLUTION: a. Check the circuit breaker located on the treadmill frame near the power cord (see the drawing above). If the circuit breaker has tripped, wait for five minutes and then press the switch back in.

b. Make sure that the power cord is plugged in. If the power cord is plugged in, unplug it, wait for five minutes, and then plug it back in.

c. Remove the key from the console. Reinsert the key fully into the console.

d. If the treadmill still will not run, call the telephone number on the front cover of this manual.

PROBLEM: The displays of the console do not function properly

SOLUTION: a. Remove the key from the console and **UNPLUG THE POWER CORD**. Remove the Screws (28) from the Hood (29), and carefully lift the Hood off.

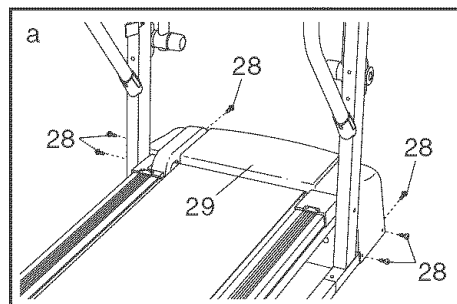

Locate the Reed Switch (13) and the Magnet (63) on the left side of the Pulley (75). Turn the Pulley until the Magnet is aligned with the Reed Switch. **Make sure that the gap between the Magnet and the Reed Switch is about 1/8"**. If necessary, loosen the Screw (28), move the Reed Switch slightly, and then retighten the Screw. Re-attach the hood, making sure that the screws are tightened into the original holes. Run the treadmill for a few minutes to check for a correct speed reading.

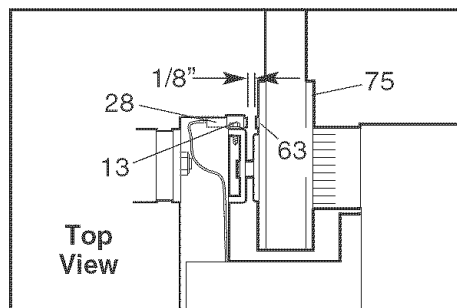

PROBLEM: The walking belt slows when walked on

SOLUTION: a. Use only a single-outlet surge suppressor that meets all of the specifications described on page 8.

- b. If the walking belt is overtightened, treadmill performance may decrease and the walking belt may become damaged. Remove the key and **UNPLUG THE POWER CORD**. Using the allen wrench, turn both rear roller adjustment bolts counterclockwise, 1/4 of a turn. When the walking belt is properly tightened, you should be able to lift each side of the walking belt 2 to 3 inches off the walking platform. Be careful to keep the walking belt centered. Plug in the power cord, insert the key, and run the treadmill for a few minutes. Repeat until the walking belt is properly tightened.

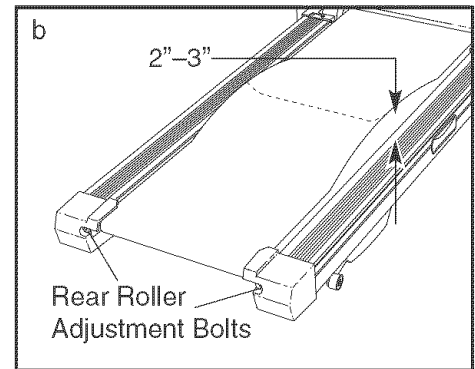

- c. If the walking belt still slows when walked on, call the number on the front cover of this manual.

PROBLEM: The walking belt is off-center or slips when walked on

SOLUTION: a. If the walking belt is off-center, first remove the key and **UNPLUG THE POWER CORD**. If the walking belt has shifted to the left, use the allen wrench to turn the left rear roller bolt clockwise 1/2 of a turn; if the walking belt has shifted to the right, turn the bolt counterclockwise 1/2 of a turn. Be careful not to overtighten the walking belt. Plug in the power cord, insert the key, and run the treadmill for a few minutes. Repeat until the walking belt is centered.

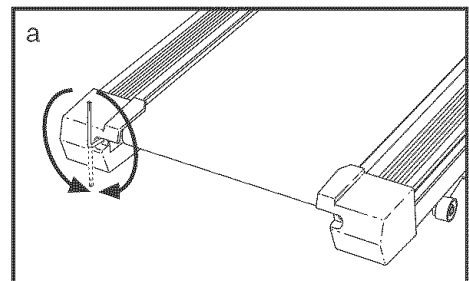

- b. If the walking belt slips when walked on, first remove the key and **UNPLUG THE POWER CORD**. Using the allen wrench, turn both rear roller bolts clockwise, 1/4 of a turn. When the walking belt is correctly tightened, you should be able to lift each side of the walking belt 2 to 3 inches off the walking platform. Be careful to keep the walking belt centered. Plug in the power cord, insert the key, and carefully walk on the treadmill for a few minutes. Repeat until the walking belt is properly tightened.

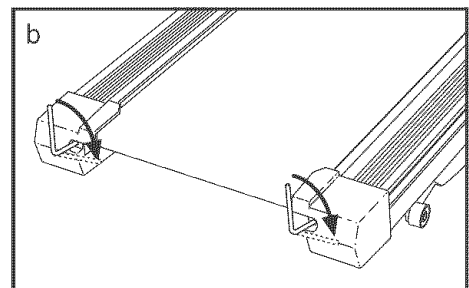

PROBLEM: The upper body arms squeak during use

SOLUTION: a. Correcting this problem requires a small amount of white marine grease, available at most hardware stores. Turn the Resistance Knob (104) counterclockwise until it can be removed. Remove the Resistance Cone (109) and the Upper Body Arm (118), along with the Resistance Plate (108), Washer (120), Spring Washer (105), Thrust Washers (107), and Thrust Bearing (106). (Note: If the Resistance Sleeve [110] or Resistance Plate [108] comes out of the Resistance Bracket [111] or Resistance Cone, press it back in.) Apply a **thin layer** of white marine grease to the outer surface of the Resistance Cone (109). Reattach all parts in the order shown at the right.

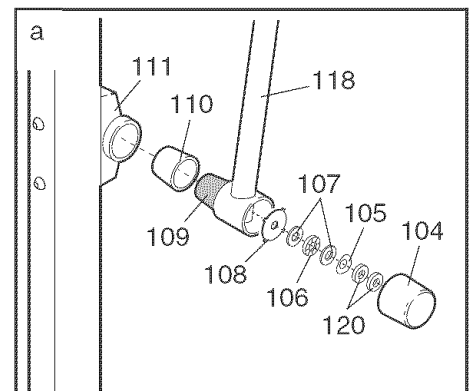

CONDITIONING GUIDELINES

⚠ WARNING: Before beginning this or any exercise program, consult your physician. This is especially important for individuals over the age of 35 or individuals with pre-existing health problems.

The pulse sensor is not a medical device. Various factors, including your movement, may affect the accuracy of heart rate readings. The sensor is intended only as an exercise aid in determining heart rate trends in general.

The following guidelines will help you to plan your exercise program. For more detailed exercise information, obtain a reputable book or consult your physician.

EXERCISE INTENSITY

Whether your goal is to burn fat or to strengthen your cardiovascular system, the key to achieving the desired results is to exercise with the proper intensity. The proper intensity level can be found by using your heart rate as a guide. The chart below shows recommended heart rates for fat burning and aerobic exercise.

AEROBIC	165	155	145	140	130	125	115
MAX FAT BURN	145	138	130	125	118	110	103
FAT BURN	125	120	115	110	105	95	90
Age	20	30	40	50	60	70	80

To find the proper heart rate for you, first find your age near the bottom of the chart (ages are rounded off to the nearest ten years). Next, find the three numbers above your age. The three numbers define your “training zone.” The lower two numbers are recommended heart rates for fat burning; the higher number is the recommended heart rate for aerobic exercise.

To measure your heart rate during exercise, use the pulse sensor.

Fat Burning

To burn fat effectively, you must exercise at a relatively low intensity level for a sustained period of time. During the first few minutes of exercise, your body uses easily accessible *carbohydrate calories* for en-

ergy. Only after the first few minutes does your body begin to use stored *fat calories* for energy. If your goal is to burn fat, adjust the speed and incline of the treadmill until your heart rate is near the lowest number in your training zone.

For maximum fat burning, adjust the speed and incline of the treadmill until your heart rate is near the middle number in your training zone.

Aerobic Exercise

If your goal is to strengthen your cardiovascular system, your exercise must be “aerobic.” Aerobic exercise is activity that requires large amounts of oxygen for prolonged periods of time. This increases the demand on the heart to pump blood to the muscles, and on the lungs to oxygenate the blood. For aerobic exercise, adjust the speed and incline of the treadmill until your heart rate is near the highest number in your training zone.

WORKOUT GUIDELINES

Each workout should include the following three parts:

A Warm-up—Start each workout with 5 to 10 minutes of stretching and light exercise. A proper warm-up increases your body temperature, heart rate and circulation in preparation for exercise.

Training Zone Exercise—After warming up, increase the intensity of your exercise until your pulse is in your training zone for 20 to 60 minutes. (During the first few weeks of your exercise program, do not keep your pulse in your training zone for longer than 20 minutes.) Breathe regularly and deeply as you exercise—never hold your breath.

A Cool-down—Finish each workout with 5 to 10 minutes of stretching to cool down. This will increase the flexibility of your muscles and will help prevent post-exercise problems.

EXERCISE FREQUENCY

To maintain or improve your condition, complete three workouts each week, with at least one day of rest between workouts. After a few months, you may complete up to five workouts each week if desired. The key to success is to make exercise a regular and enjoyable part of your everyday life.

SUGGESTED STRETCHES

The correct form for several basic stretches is shown at the right. Move slowly as you stretch—never bounce.

1. Toe Touch Stretch

Stand with your knees bent slightly and slowly bend forward from your hips. Allow your back and shoulders to relax as you reach down toward your toes as far as possible. Hold for 15 counts, then relax. Repeat 3 times. Stretches: Hamstrings, back of knees and back.

2. Hamstring Stretch

Sit with one leg extended. Bring the sole of the opposite foot toward you and rest it against the inner thigh of your extended leg. Reach toward your toes as far as possible. Hold for 15 counts, then relax. Repeat 3 times for each leg. Stretches: Hamstrings, lower back and groin.

3. Calf/Achilles Stretch

With one leg in front of the other, reach forward and place your hands against a wall. Keep your back leg straight and your back foot flat on the floor. Bend your front leg, lean forward and move your hips toward the wall. Hold for 15 counts, then relax. Repeat 3 times for each leg. To cause further stretching of the achilles tendons, bend your back leg as well. Stretches: Calves, achilles tendons and ankles.

4. Quadriceps Stretch

With one hand against a wall for balance, reach back and grasp one foot with your other hand. Bring your heel as close to your buttocks as possible. Hold for 15 counts, then relax. Repeat 3 times for each leg. Stretches: Quadriceps and hip muscles.

5. Inner Thigh Stretch

Sit with the soles of your feet together and your knees outward. Pull your feet toward your groin area as far as possible. Hold for 15 counts, then relax. Repeat 3 times. Stretches: Quadriceps and hip muscles.

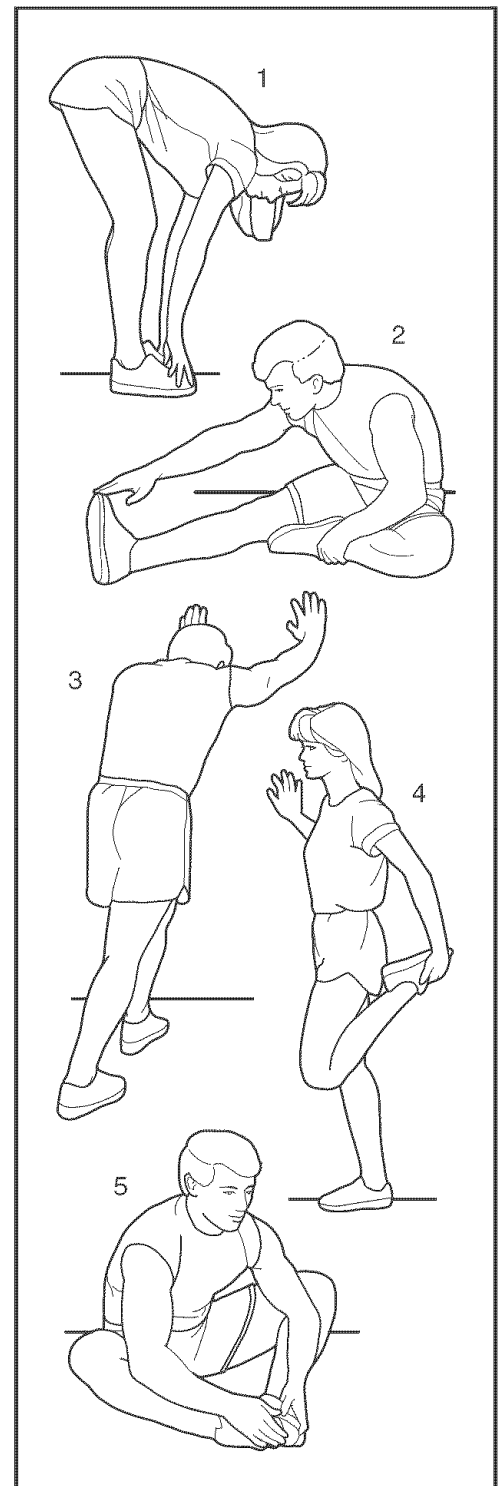

PART LIST—Model No. DTL3495.0

R0305A

Key No.	Qty.	Description	Key No.	Qty.	Description	Key No.	Qty.	Description
1	4	Front Endcap Screw	45	1	Reset/Off	88	1	Motor Shield
2	6	Star Washer			Circuit Breaker	89	3	Isolator Screw/ Catch Screw
3	2	Plastic Tie	46	1	Grommet	90	1	Right Rear Endcap
4	1	Left Handrail	47	1	Power Cord	91	1	Left Front Endcap
5	12	3/4" Screw	48	1	Motor Tension Nut	92	4	Incline Nut
6	1	Key/Clip	49	1	Console Assembly	93	1	Incline Stop Bracket
7	1	Hole Plug	50	1	Right Foot Rail	94	1	Incline Motor Bolt, Lower
8	1	Incline Leg	51	2	Platform Screw, Rear			
9	2	Handrail Endcap	52	1	Front Roller Adj. Bolt	95	2	Incline Motor Nut
10	1	Wire Cover	53	1	Wire Harness	96	1	Incline Motor
11	1	Console	54	2	Incline Wheel Bolt	97	4	1/2" Screw
12	1	Console Cover	55	2	Incline Wheel	98	2	Crossbar Screw
13	1	Reed Switch	56	1	5/32" Allen Wrench	99	1	Silver Ground Screw
14	2	Extension Leg Screw	57	1	Choke	100	1	Crossbar
15	2	Extension Leg	58	2	Belt Guide	101	2	U-nut
16	1	Right Handrail	59	1	Console Warning Decal	102	4	Resistance Bracket Bolt
17	2	Handrail Bracket				103	1	Handrail Cap
18	1	Motor Belt	60	2	Isolator	104	2	Resistance Knob
19	2	Motor Tension Bolt	61	1	Catch	105	2	Spring Washer
20	1	Motor Tension Washer	62	1	Frame Spacer, Left	106	2	Thrust Bearing
21	5	Star Washer	63	1	Magnet	107	4	Thrust Washer
22	1	Motor Pivot Nut	64	2	Incline Leg Pivot Bolt	108	2	Resistance Plate
23	1	Drive Motor	65	1	Belly Pan	109	2	Resistance Cone
24	1	Motor Bolt	66	1	Latch	110	2	Resistance Sleeve
25	4	Star Washer	67	1	Walking Belt	111	2	Resistance Bracket
26	1	Motor Pivot Bolt	68	3	Wire Tie	112	2	Resistance Bolt
27	5	8" Cable Tie	69	4	Wire Tie Clamp	113	2	Front Isolator
28	28	Screw	70	1	Incline Wire	114	2	Upper Body Arm Screw
29	1	Hood	71	1	Walking Platform			
30	1	Hood Shield	72	2	Plastic Fastener	115	2	Foam Grip
31	4	Base Pad Screw	73	1	Left Foot Rail	116	1	Warning Decal
32	1	Frame Spacer, Right	74	1	Sensor Clip	117	2	Platform Screw, Front
33	4	Base Pad	75	1	Front Roller/Pulley	118	1	Left Upper Body Arm
34	1	Motor Belly Pan	76	6	Electronic Screw	119	1	Right Upper Body Arm
35	1	Controller	77	1	Ground Wire	120	4	Resistance Washer
36	2	Frame Pivot Bolt	78	2	Rear Roller Adj. Bolt	#	1	Hole Plug
37	2	Frame Pivot Washer	79	1	Left Rear Endcap	#	1	4" Black Wire, 2F
38	1	Upright/Base	80	1	Upright Grommet	#	1	4" Blue Wire, 2F
39	4	Belt Guide Screw	81	1	Allen Wrench	#	1	4" White Wire, M/F
40	6	Washer	82	1	Latch Decal	#	1	6" Green Wire, F/R
41	2	Wheel Bolt	83	1	Rear Roller	#	1	User's Manual F/Ring
42	2	Wheel	84	1	Frame			
43	6	Frame Nut/Wheel Nut	85	1	Bookrack			
44	2	Handrail Bolt	86	1	Right Front Endcap			
			87	1	Console Base			

#These parts are not illustrated

EXPLODED DRAWING—Model No. DTL3495.0

R0305A

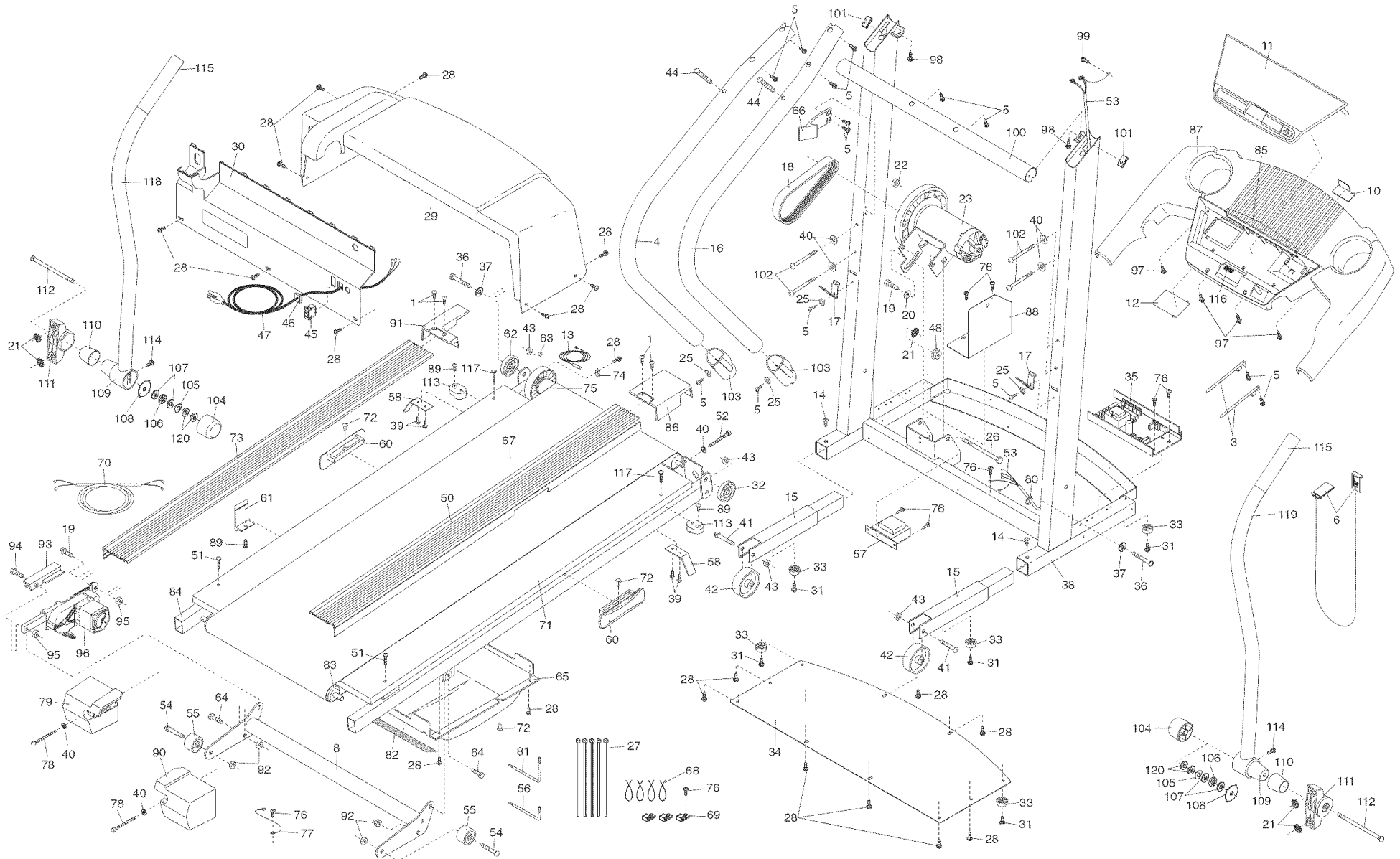

ORDERING REPLACEMENT PARTS

To order replacement parts, see the front cover of this manual. To help us assist you, please be prepared to give the following information:

- The MODEL NUMBER of the product (DTL3495.0)
- The NAME of the product (PROFORM CROSSWALK 365e treadmill)
- The SERIAL NUMBER of the product (see the front cover of this manual)
- The KEY NUMBER and DESCRIPTION of the part(s) (see the PART LIST and the EXPLODED DRAWING in the center of this manual)

LIMITED WARRANTY

ICON Health & Fitness, Inc. (ICON), warrants this product to be free from defects in workmanship and material, under normal use and service conditions. The drive motor is warranted for three (3) years after the date of purchase. The parts and labor are warranted for ninety (90) days after the date of purchase.

This warranty extends only to the original purchaser. ICON's obligation under this warranty is limited to replacing or repairing, at ICON's option, the product through one of its authorized service centers. All repairs for which warranty claims are made must be pre-authorized by ICON. If the product is shipped to a service center, freight charges to and from the service center will be the customer's responsibility. For in-home service, the customer will be responsible for a minimal trip charge. This warranty does not extend to any product or damage to a product caused by or attributable to freight damage, abuse, misuse, improper or abnormal usage or repairs not provided by an ICON authorized service center; to products used for commercial or rental purposes; or to products used as store display models. No other warranty beyond that specifically set forth above is authorized by ICON.

ICON is not responsible or liable for indirect, special or consequential damages arising out of or in connection with the use or performance of the product or damages with respect to any economic loss, loss of property, loss of revenues or profits, loss of enjoyment or use, costs of removal or installation or other consequential damages of whatsoever nature. Some states do not allow the exclusion or limitation of incidental or consequential damages. Accordingly, the above limitation may not apply to you.

The warranty extended hereunder is in lieu of any and all other warranties and any implied warranties of merchantability or fitness for a particular purpose is limited in its scope and duration to the terms set forth herein. Some states do not allow limitations on how long an implied warranty lasts. Accordingly, the above limitation may not apply to you.

This warranty gives you specific legal rights. You may also have other rights which vary from state to state.

ICON HEALTH & FITNESS, INC., 1500 S. 1000 W., LOGAN, UT 84321-9813