



User's / Programming Guide

Handheld Laser Bar Code Scanners

Keyboard Wedge /

Wand Emulation Interface

PSC INC.

If you have any questions or need assistance after reading this manual, please contact PSC Customer Service at:

PSC Inc.
675 Basket Road
P.O. Box 448
Webster, New York 14580-0448

Telephone: 716-265-1600
800-828-6489

Fax: 716-265-6400

The descriptions and specifications herein were in effect at the time of manual production. Every effort was made to make the information complete and correct.

No part of this manual may be reproduced or utilized in any form or by any means, electronic or mechanical, including photocopying or electronic transmission, or other means of reproduction or distribution without prior written consent of PSC Inc.

The drawings, specifications and other technical information contained in this manual are the property of PSC Inc. and shall not be copied, reproduced or used in any way; in whole or in part, as the basis of manufacture or sale of similar items without the prior written consent of PSC Inc.

The information contained in this manual is subject to change without notice.

PSC, the PSC logo and AutoSense are registered trademarks and QuickScan is a trademark of PSC Inc.

©2000 PSC Inc. All rights reserved.

Scanners discussed in this manual are covered by patents issues or pending in the U.S. and other countries.

NOTICE

The scanner is certified to be a Class II laser product with the United States Department of Health and Human Services Center for Devices and Radiological Health.

NOTICE

The scanner, as a component, has been tested for compliance with the EMI requirements of the United States Federal Communications Commission Part 15, Sub-Part J, Class A. Original equipment manufacturers (OEMs) are responsible for testing the scanner with their equipment to ensure system compliance with FCC requirements.

THIS APPARATUS COMPLIES WITH THE CLASS "A" LIMITS FOR RADIO INTERFERENCE AS SPECIFIED IN THE CANADIAN DEPARTMENT OF COMMUNICATIONS RADIO INTERFERENCE REGULATIONS.

CET APPAREIL EST CONFORME AUX NORMES CLASS "A" D'INTERFERENCE RADIO TEL QUE SPECIFIER PAR LE MINISTERE CANADIEN DES COMMUNICATIONS DANS LES REGLEMENTS D'INTERFERENCE RADIO.

Table of Contents

Introduction	1
Keyboard Wedge Mode.....	1
Serial Communications Mode.....	1
AutoSense® Mode	1
Wand Emulation Mode	1
Magnetic Stripe Reader.....	1
Unpacking	2
Installation	2
Keyboard Wedge	2
Cable Installation	2
Connecting the Power Supply	3
Connecting a Magnetic Stripe Reader.....	3
Terminal Power-Up Sequence	3
Serial Communications	4
Serial TTL Mode	4
Serial RS232 Mode	4
AutoSense® Operation	5
Wand Emulation Operation	7
Setup Overview	8
Wedge Mode Options.....	8
Wand Emulation Options.....	8
Serial Communication and Wedge Options.....	9
Symbologies	10
Parameters Selection Guidelines	11
Examples	11
Serial Communication	13
Reset Default	13
Baud Rate.....	13
Data Transmission.....	14
Communications Protocol.....	16
Label Buffering	19
No Read Option.....	19
Menu Commands Parameter Messages	20
External Trigger Operation	20
General Parameters	21
Intercharacter Delay	21
Transmission Mode	22

System Status	22
Power Consumption	23
Laser Redundancy	23
Laser Timeout	24
Beeper Operation	24
Message Formatting	25
Prefixes and Suffixes	25
Prefix	26
Suffix	26
Code Identifier	28
Preamble or Postamble Selection	29
Preamble	29
Postamble	29
Serial Commands	31
General Serial Command Format	31
ACK/NAK	31
Beeper Off CR-LF Ack	32
Power Standby and Serial Commands	33
Communication Parameter Changes	33
Manual Scanning Interaction	33
Keyboard Wedge Parameters	34
Symbologies 38	
UPC (A and E)	38
EAN/JAN	42
Code 39	44
Code 2 of 5 – Interleaved	46
Code 2 of 5 – Standard	47
Code 128	48
MSI/Plessey	50
Code 11	50
Code 93	51
16K	52
Digit Selection	53
Symbology Identifiers	54
Wand Emulation Parameters	58
Select Code Type	58
Bar Code Polarity	58
Transmission Rate	58
Data Synchronization	60

Memory Module	62
Setup.....	63
Marker Beam	64
Scanner Labeling.....	66
Service and Warranty	66
Maintenance	67
Cleaning	67
Inspection	67
Appendix A	69
Hexadecimal Conversion Tables.....	69
Primary Function Key Table	72
Secondary Function Key Tables.....	73

Introduction

Keyboard Wedge Mode

As a keyboard wedge interface, the PSC scanner can be used with terminals provided by most of the major terminal manufacturers. In most cases, the PSC scanner is easily connected between the keyboard and display of the terminal. The use of Preamble/Postamble, embedded keyboard function codes or keyboard function records allow operation of the terminal without manual entry from the keyboard. In this mode of operations, the PSC scanner draws power from the terminal.

Serial Communications Mode

The PSC scanner can be configured by the user for a serial communication output. In this mode, the scanner can be connected to any device that accepts serial ASCII data at TTL voltage levels. RS232 voltage levels can be achieved by the use of an optional RS232 conversion pod.

AutoSense[®] Mode

The PSC scanner may be configured at the factory with PSC's AutoSense[®] feature. AutoSense[®] operates with a passive stand for hands-free operation. When the scanner is placed in the stand, it becomes immediately active for reading any bar code label presented to it. The user can remove the scanner from the AutoSense[®] Stand and use it as a conventional hand-held scanner. When replaced in the stand, the scanner reverts automatically to AutoSense[®].

Wand Emulation Mode

The PSC scanner can be configured by the user for Wand Emulation. In this mode, the PSC scanner can be connected to any device that accepts a wand signal input. Wand Emulation communication presents bar code data to a host device exactly as a wand does. This precludes the use of any option which adds information to the bar code symbol data (preamble, for example). A typical example of this would be to interface the scanner to a portable data terminal for remote data collection.

Magnetic Stripe Reader

Magnetic stripe reading capabilities are available with appropriate cabling.

Unpacking

Your package should include a scanner, interface cable, User's Manual, and a plastic scanner holder.

The unit should be inspected immediately upon receipt to determine if any damage has occurred during shipment. If damage has occurred, a claim should be filed with the carrier immediately.

Retain the shipping box, since it should be used to return the scanner to the factory for service.

Installation

Keyboard Wedge

In Keyboard Wedge mode the PSC scanner simulates keyboard key-strokes. Whether a person has pressed a key on the keyboard or data has been transmitted from the scanner is indistinguishable by the host device. When the PSC scanner is not transmitting data to the terminal the keyboard operates as if the PSC scanner was not attached.

Installation of the PSC scanner should be completed by a user who is familiar with installing computer systems and cabling.

Cable Installation

1. Turn off power to the terminal to which the PSC scanner will be connected.
2. Verify that you received the correct cabling. The cable supplied for keyboard wedge installation is referred to as a "Y" cable.
3. Connect the modular plug to the PSC scanner. Insert plug into the rectangular opening in the bottom of the scanner handle.
4. Unplug the keyboard from the terminal and replug the keyboard into the short leg of the "Y" cable that mates with it.
5. Plug the remaining long leg of the "Y" cable into the terminal where the keyboard was connected.
6. Arrange the fully connected unit so that all cables run freely.

Connecting the Power Supply

If supplied, plug the connector from the external power supply into the receptacle located on the housing connector. Then plug the power supply into a power source.

Connecting a Magnetic Stripe Reader

If a detached Magnetic Stripe Reader (MSR) is to be used, plug the connector into the MSR receptacle located on the housing connector.

Terminal Power-Up Sequence

Turn on the power to the terminal to which the PSC scanner is connected. The unit will issue a series of beeps which are intentional and indicate that the terminal/keyboard power-on reset routines have been completed.

Programming for Terminal Type



If this is a first-time installation, it is **NECESSARY** to program the PSC scanner for use with the connected terminal.

Proceed as follows:

1. Using the Keyboard Wedge Parameters menu given in the Keyboard Wedge Parameters Section scan:

WEDGE MODE ENABLE (CE)

This sets the PSC scanner into a Keyboard Wedge interface mode.

2. Select the terminal type by next scanning the appropriate symbol for your terminal.

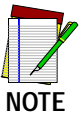

Scanning Reset to Default (ZA) will cause the PSC scanner to revert to Keyboard Wedge mode with a PC-AT terminal type.

Serial Communications

The PSC scanner provides the user with two different serial communications options: Serial TTL and Serial RS232 communications.

Serial TTL Mode

Serial TTL is a serial communications interface that uses TTL/CMOS voltage levels ranging from 0 to 5 volts. The user can select a normally high (default setting) or normally low (inverted) voltage levels. Serial TTL communications mode uses different cables than those used in keyboard wedge applications. To configure the PSC scanner in a Serial TTL mode, the user must have the appropriate cable with the correct signal pinouts in order to interface the scanner to the host terminal. To program the PSC for Serial TTL communications, the user must first identify the serial communications parameters supported by the host terminal. Typical parameters are the baud rate, parity and number of bits in the data word. These parameters are discussed in the section on Serial Communication Parameters. The PSC scanner has the added versatility to enable the user to select the quiescent voltage levels for interfacing with terminals that require inverted signals.

Serial RS232 Mode

The PSC scanner can also be used in an RS232 environment by converting the serial TTL voltage levels to RS232 voltage levels. For this installation, the user needs an optional cable, an adapter pod, and a power supply.

When the PSC scanner is operated with the RS232 adapter pod, the same serial communications parameters apply as those used in a serial TTL environment. The only difference is that the RS232 adapter pod inverts the polarity of all the signals passing through it. Therefore, the user needs to program the scanner for serial communication, normal polarity (symbol CA). RS232 levels are available only in full continuous power mode.

AutoSense® Operation

AutoSense® is a factory installed feature requested at time of order. It provides for hands-free or handheld operation. AutoSense® is activated by scanning the Enable AutoSense® symbol. The scanner will respond by emitting a continuous, low level red beam of light known as the trigger beam. AutoSense® is deactivated by scanning the Disable AutoSense® symbol.

When the AutoSense® feature is used with PSC's AutoSense® stand (specifically designed for standard and HP scanners), the user must first attach the plastic scanner holder to the bracket of the stand as shown in Figure 1, next page. The scanner is then mounted into the holder. Insure that the trigger beam is aimed at the reflective tape affixed to the stand. AutoSense® is now ready to automatically scan bar code labels presented to it. When the trigger beam is broken by the bar code label, the scan beam will automatically engage and decode the bar code symbol. Any time the scan beam disappears, whether by a decode or by a scan beam timeout, the automatic trigger must be re-enabled by allowing the trigger beam to sense the reflective tape.

While AutoSense® is activated, the user is able to remove the scanner from its holder and use it for handheld scanning operation. When the scanner is removed from the AutoSense® holder, the trigger beam will be broken and the scan beam will automatically be engaged. If the scanner does not decode a bar code symbol, the scanning beam will turn off after two to six seconds. Scanning is re-initiated by manually pulling the trigger. When the scanner is replaced into the holder AutoSense® will be automatically re-engaged when the trigger beam senses the reflective tape.



NOTE

When the scanner is powered from a battery, such as in a hand-held terminal, AutoSense® should be disabled. In a battery powered application, the user is strongly recommended to use the power conservation feature of scanner operation. Power conservation reduces power draw from the battery between scans to extremely low levels. AutoSense® will function only in full power mode.

NO



Enable AutoSense®

NN



Disable AutoSense®

To use this mode of operation properly, the user must first attach the plastic scanner holder to the bracket of the stand as shown in Figure 1. The (NO) Enable AutoSense® programming symbol is scanned until the green “Good Decode” light blinks. This will activate the trigger screen. The scanner is then placed into the holder and the user must check that the red laser beam is aimed at the reflective label affixed to the stand. The AutoSense® is now ready to read labels presented to it.

Figure 1. The PSC AutoSense® Stand

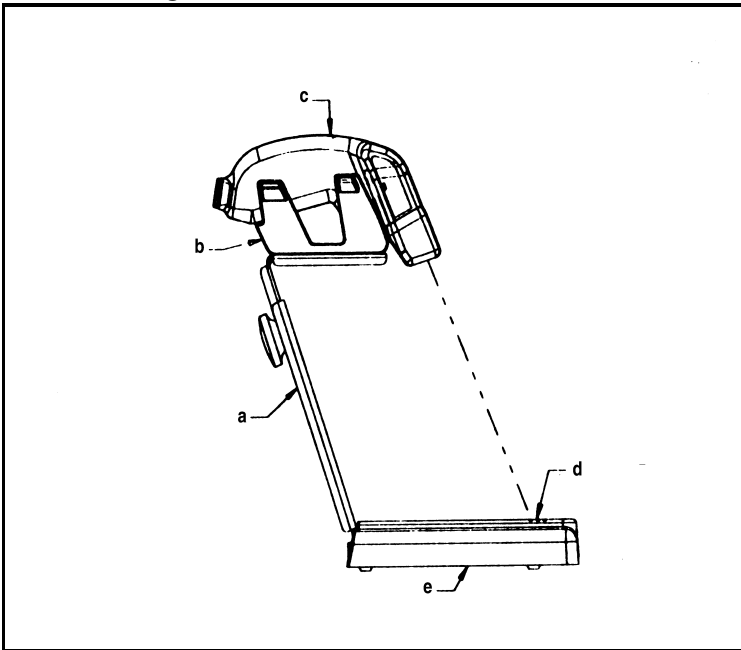

- a. Riser sub-assembly
- b. Scanner holder
- c. Scanner

- d. Reflective tape
- e. Stand base

Wand Emulation Operation

To operate the PSC scanner in Wand Emulation the user must first turn off the power to the host device and then detach the scanner from the host device by removing the cable from the scanner.

The proper Wand Emulation cable must be connected between the scanner and the portable data terminal for remote data collection. If using an optional Smart Cable, the scanner automatically switches to Wand Emulation. Specific Wand Emulation parameters may still need to be set. If using a cable without Smart Cable switching, the user must then configure the scanner to its Wand Emulation mode by scanning the symbol CC.

CC  Same Code Wand Emulation

This symbol activates the following default parameters:

Code Type = Same Code Wand Emulation

Code type, bar code polarity, and transmission rate can each be set for Wand Emulation. Menu symbols for these parameters are found in the section on Wand Emulation Parameters.

When the user with a Smart Cable again connects to the host device, the scanner will automatically revert to the original communication mode. Without Smart Cable, scan the appropriate programming symbol.

CE  Enable Wedge

CA  Enable Serial Mode

Setup Overview

General setup parameters are divided into Keyboard Wedge options (communication to host through the terminal keyboard), Wand Emulation options (communication between the scanner and the host system's decoder), and Serial Communication options (communications direct to the host system).

Default options are denoted throughout the manual as follows:

- Keyboard Wedge @
- Wand Emulation #
- Serial Communication *

Wedge Mode Options

Several wedge mode options are available. Consult the Keyboard Wedge Parameters section for a complete list.

Wand Emulation Options

The available wand emulation options, listed below, are found in the section Wand Emulation Parameters.

Bar Code Polarity

- Black High
- White High

Transmitted Code Type

- Same Code Wand Emulation
- Converted to Code 39 (full ASCII)

Simulated Scan Rate

- 5 inches per second
- 10 inches per second
- 15 inches per second
- 20 inches per second
- 50 inches per second
- 70 inches per second

Data Synchronization

- Disable Data Synchronization
- Enable Data Synchronization
- Active Polarity High
- Active Polarity Low

Serial Communication and Wedge Options

The following communication options are used to define how your PSC scanner communicates with the host system through its serial interface or its keyboard wedge interface.

A message transmitted from the scanner upon a successful decode has the following format:

Prefix	Terminal ID	Preamble	Code ID	Data	Postamble	Suffix
--------	-------------	----------	---------	------	-----------	--------

Some of these attributes, e.g., prefix, preamble, etc., may not be required or may vary from one host system to another. The parameter selection process allows you to tailor these elements for the particular requirements of your host system. You may also program an inter-character delay to prevent data overrun problems with your host terminal.

Options specific to serial communications are:

Baud Rate	Protocol
Parity	Inverted Serial
Stop Bits	External Trigger
Word Length	Buffering Level

Each of these options is discussed in greater detail in the section on Serial Communication Parameters.

Symbologies

The bar codes that can be read by PSC's bar code scanners include:

Code 39	Code 93
Interleaved 2 of 5	Code 128
Standard 2 of 5	Codabar
UPC-A, UPC-E	Code 11
EAN/JAN	MSI/Plessey

A complete list of the related options and the instructions for setting them are provided in the section on Symbologies.



NOTE

Scanning problems are most often caused by poor quality bar code symbols. If scanning problems arise, test your bar code system using the high quality bar code test symbols supplied in this manual or contact your PSC Customer Service representative.

Parameters Selection Guidelines

Three basic steps must be followed when selecting parameters for your scanner.

1. Review this manual to be sure you understand the terminology.
2. Review the requirements of your host system, with a technical expert from your company, if necessary. This will enable you to determine if any of the factory default settings must be altered.
3. Enable or disable the relevant parameters by scanning the appropriate menus. This operation is described in more detail in the following example.

Examples

Assume that the beeper volume is too loud at its default setting. To change the beeper volume from its default value of loud to a setting of low, locate the beeper volume bar code menu in the General Parameters section. Then scan the label to the left of Beeper On, Volume Low. The correct label is reproduced below.

AB



Beeper On; Volume Low



NOTE

When enabling or disabling a parameter, be sure the scanner beam illuminates only one bar code symbol at a time. The layout of this manual minimizes accidental multiple-label scanning.

A successful scan is indicated by two short-high beeps. An unsuccessful scan produces no beeps and requires you to rescan the Beeper On; Volume Low bar code.

Most parameters are modified in this way, and you may resume normal bar code scanning when no further modifications are desired.

Some parameters require multiple scans to modify a setting; for example, Intercharacter Delay. If you wish to set this parameter to 5 milliseconds (msec.):

-
1. Scan the bar code beside Intercharacter Delay = XX and listen for one short-high beep.
 2. After the beep, scan the bar code beside 0 on the Digit Selection page and listen for one short-high beep.
 3. Still at the Digit Selection page, scan the bar code for 5 (the last argument in the command) and listen for two short beeps.

Your PSC scanner does not have a distinct programming mode. Instead, it automatically recognizes and reacts to the labels you scan. If, for example, you scan INTERCHARACTER DELAY = XX and then scan a normal data label, a normal tone is emitted in response to the data label, and the programming command is ignored. *No special exit code is required to resume normal operations.*

Serial Communication

Reset Default

To program the communication mode for serial asynchronous communication, scan the following label:

CA  Select Serial Output

Baud Rate

There are seven standard serial communication baud rates to select from. Your scanner and the serial host computer **must** be set to the same baud rate. Select the correct rate.

DA  Baud Rate = 300 Baud

DB  Baud Rate = 600 Baud

DC  Baud Rate = 1200 Baud

DD  Baud Rate = 2400 Baud

DE  Baud Rate = 4800 Baud

DF  Baud Rate = 9600 Baud *

DG  Baud Rate = 19200 Baud

Data Transmission

Serial transmission data is composed of three or four different elements, depending upon host system requirements. These elements are the START bit, DATA bits (7 or 8 bits), OPTIONAL PARITY bits, and STOP bit (s) (1 or 2 bits).

The PARITY bit is used for error detection (e.g., data altered in transmission), but is not required by all systems. A parity bit, if required, will be in one of the following four formats:

If your system requires a WORD length of 7 bits, one or two STOP bits, and a PARITY check, select the appropriate option from Table 1.

Table 1. 7 Bit Options













Data	Stop Bits	Parity	Option
7	1	Odd	ED 
7	1	Even	EC 
7	1	Mark	EB 
7	1	Space	EA* 
7	2	Odd	EH 
7	2	Even	EG 

Table 1. 7 Bit Options

Data	Stop Bits	Parity	Option
7	2	Mark	EF 
7	2	Space	EE 

If your system requires a WORD length of 8 bits, 1 or 2 STOP bits, and PARITY check, select the appropriate option from the table below:

Table 2. 8 Bit Options

Data	Stop Bits	Parity	Option
8	1	Odd	EL 
8	1	Even	EK 
8	1	Mark	EJ 
8	1	Space	EI 

If your system requires a WORD length of 8 bits and 1 or 2 STOP bits, but no PARITY, select the option below:

Table 3. 8 Bit, No Parity

8	1	None	EM 
8	2		EN 

PARITY check is not possible with this combination of STOP bits and WORD length.

Some receiving equipment requires inverted serial communication signals.

CD  Inverted Serial Communications

Communications Protocol

XON/XOFF

Protocol controls data flow between your PSC scanner and a serial host computer. If Protocol = XON/XOFF is selected, the scanner recognizes the ASCII XON/XOFF characters. The host may then stop transmission with XOFF and resume with XON.

Controlled data flow is achieved between devices when the receiving device sends ASCII XON/XOFF codes to the transmitting device. In other words, when the receiving device is unable to accept data, it sends an XOFF code to inform the host to temporarily suspend data transmission.

When the receiving device “catches up,” it sends an XON code to inform the host that it is again ready to accept data. An advantage of this protocol is that additional hardware is not required for implementation; only transmit, receive, and signal ground are required.

CTS

Like XON/XOFF protocol, CTS protocol is a mechanism used to control data flow out. The CTS input is used to inform the scanner that the host terminal is ready to accept scanned data. When CTS (+) protocol is selected, the scanner waits for a low level on its CTS input before transmitting data. When CTS (-) is selected, the signal polarities are reversed and a high level indicates data may be transmitted. The CTS protocol may be programmed independently of the RTS protocol; however, the signal polarities must be the same. You may not select CTS (+) and RTS (-).

RTS

The RTS output from the scanner may be programmed to operate in one of three different modes. In the default mode RTS signals when the scanner is ready to receive commands or data. In the second mode, RTS is in a fixed state. In the third mode, RTS signals when the scanner has data to transmit. The RTS modes are independent of the CTS protocol. However, you must select the same active state for RTS as for CTS. You may not select CTS (-) and RTS fixed low. If CTS (-) is selected, then the active state for RTS will be high.



NOTE

The specified levels are at the modular connector and are inverted when using an RS232 converter pod.

HA



CTS Protocol = None*
RTS low indicates scanner ready to receive data

HB









Protocol = XON/XOFF

HC



Protocol = CTS (-)

HD		Protocol = CTS (+)
HG		RTS always low
HH		RTS always high
HI		RTS high indicates scanner ready to receive data
HJ		RTS low indicates scanner has data to transmit
HK		RTS high indicates scanner has data to transmit

Another flow control option is available. If enabled, the stop/go protocol disables the trigger after every successful scan. The trigger is then re-enabled with a serial 'BG' command in format <STX><ESC>BG<ETX>.

BS		Disable Stop/Go Protocol*
BT		Enable Stop/Go Protocol

Label Buffering

The user may select one of three levels of serial buffering. With Full Buffering (the default) selected, the scanner will place all scanned labels into a buffer for transmission. This allows the operator to continue scanning even though the previous label may not have been transmitted yet. Scanning will continue normally until the buffer is full, then scanning will stop. Scanning will continue when enough space is available for the current label.



When No Buffering is selected then scanning will be stopped until the current label is completely transmitted.

When One Label Buffering is selected the scanner will allow the operator to scan one more label in addition to the label already in the transmit buffer. In other words, one label may be scanned beyond the label being transmitted.

NE		Full Buffering
NF		No Buffering
NG		One Label Buffering

No Read Option

The scanner can be programmed to send a no read message ('NR') upon a scan that does not result in a good read.

NX		Enable No Read
NY		Disable No Read *

Menu Commands Parameter Messages

In serial mode, most menu commands when scanned will provide a confirmation message to the host along with the ACK. This feature can be enabled or disabled.

BA  Enable Parameter Messages *

BB  Disable Parameter Messages

External Trigger Operation

External trigger operation enables an external device to control scanning. External trigger is controlled by applying an external trigger signal to the CTS input (with external triggering enabled). When active, this signal causes scanning to begin just as if the scanner's trigger were depressed. Scanning continues until a label is decoded or the external trigger signal is deactivated.

In the event of a decode, the trigger signal **must** be deactivated for a minimum of 50 milliseconds before another scan can be attempted ("tying" the trigger signal active does not cause continuous scanning and decoding).

When EXTERNAL TRIGGER(+) is scanned, scanning begins when a high level input is applied to the CTS input. Conversely, when EXTERNAL TRIGGER(-) is scanned, scanning begins when a low level is applied to CTS. When CTS is not connected, it is treated as if a high level is applied. The voltage levels given are at the modular connector. If an RS232 converter pod is used, then the levels are inverted.

HA  Disable External Trigger#*@

HE  External Trigger(+)

HF



External Trigger(-)

General Parameters

Intercharacter Delay

Certain terminals and computers require an intercharacter delay to simulate the effects of keystroke delays. Choosing an intercharacter delay causes the characters to be sent at the slower speed required by the device to which you are interfacing.

GA



No Intercharacter Delay



NOTE

To set Intercharacter Delay to other than zero, scan the label below and then scan two separate digits from the Digit Selection page (99 maximum).

GB



Intercharacter Delay = XXMEC



NOTE

Intercharacter delay cannot exceed 99 milliseconds.

Interlabel delay allows user to program a delay between transmitted labels.

GC



No interlabel delay *@

GD



Set interlabel delay 0-9.9 seconds

Transmission Mode

Full Duplex or Half Duplex

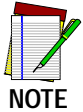

This section pertains only to models with a Liquid Crystal Display (LCD)

Transmission mode selects either full or half duplex operation regardless of interface. In the half duplex mode, the decoded message is sent simultaneously to the display and to the host computer. In the full duplex mode, the message is sent to the host computer. In send mode, the host always has the capability to send a message directly to the LCD.

The advantage of the full duplex mode is that the display shows the message received by the host. In the half duplex mode you can see that the message has been sent but there is no confirmation that it was received. The disadvantage of the full duplex mode is simply that the host computer must be programmed to relay the message back to the scanner.

NA  Transmission Mode = Full Duplex

NB  Transmission Mode = Half Duplex *#

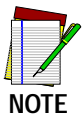

For models which do not have an LCD, parameter selections NA and NB have no effect.

System Status

To examine the configuration of your system, scan the appropriate option.

When Option ZB is scanned, a list of currently programmed parameters is sent to the display device. *Scanning ZB may interfere with your terminal software, depending on your application.*

ZB



Display Configuration

When Option ZC is scanned, the program version followed by carriage return-line feed characters (CR-LF) is sent in the format <software name>SP<###> (WDHB 3.86, for example).

ZC



Transmit Version Number

Power Consumption

You may choose one of two Power Consumption modes. Option @A supplies full power to the scanner at all times; Option @B allows the unit to revert to a standby mode after a successful read. This mode is a power conservation feature.

@A



Enable Continuous@ Full Power

@B



Enable Standby *#

Laser Redundancy

For a successful decode to occur when Laser Redundancy is enabled, two laser scans of the bar code must match. Because the laser scans a label many times a second, you will notice little or no change in the speed of the decode. Laser redundancy can be used to enhance the security of the bar code reader.

BC



Disable Laser Redundancy *#@

BD



Enable 2 Times Laser Redundancy

BE



Enable 4 Times Laser Redundancy

Laser Timeout

The scan beam will activate in response to a trigger pull. The beam will automatically deactivate after a label is decoded. If a label is **not** decoded., the scan beam will timeout and deactivate after several seconds. Scan the following labels to control the length of the timeout.

BH



Set Scan Beam *#@ Timeout to 6 Seconds

BI



Set Scan Beam Timeout to 4 Seconds

BJ



Set Scan Beam Timeout to 2 Seconds

BO



Set Scan Beam Timeout to 1 Second

BW



Set Scan Beam Timeout to ½ Second

Beeper Operation

Scan one of the options below to modify beeper operation.

AA



Beeper Off

AB



Beeper On; Volume Low

AC



Beeper On; Volume Medium

AD



Beeper On; Volume Loud *#@

Message Formatting

Message formatting describes how to format the data (decoded string) that is sent from the scanner to the host.



NOTE

The programmable options **DO NOT** apply in Wand Emulation.

Prefixes and Suffixes

Prefix	Terminal ID	Preamble	Code ID	Data	Postamble	Suffix
--------	-------------	----------	---------	------	-----------	--------

Prefixes, Suffixes, Preambles and Postambles are programmable attributes that are transmitted along with the decoded label data to the host device. These attributes are handled differently whether the scanner is configured for serial mode or wedge mode. When configured for wedge mode these attributes are sent as keystrokes. The scanner automatically translates the ASCII characters into keystrokes before sending data to the host. Refer to the keystroke translation tables for non-printable ASCII characters.

Prefix

A prefix is a subset of the preamble normally formatted to some industry standard, i.e., it is represented by a specific ASCII code. An example of a prefix is the STX (Start of Transmission) code.

IA  Prefix = None*#

IB  Prefix = STX

IC  Prefix = SOH

Suffix

A suffix is a subset of the Postamble. Like the prefix, it is normally assigned a specific ASCII code. Examples of suffixes are CR (Carriage Return) and LF (Line Feed).

MA  Suffix = None #

MB  Suffix = ETX

MC  Suffix = CR

MD  Suffix = LF

ME  Suffix = HT

MF



Suffix = CR and LF *

Users also have the ability to select any ASCII character for use as a suffix.

Scan the MJ label, then scan two labels from the Hexadecimal Conversion Table representing the character needed for the suffix.

MJ



Select Programmable
Suffix Character

Certain specialized applications require a two character suffix of ETB NUL. Scanning MI provides this.

MI



Select Suffix = ETB NUL

Terminal ID

Terminal ID characters are used to identify individual scanners when more than one scanner is interfaced with the host system. Options available are none (DISABLED) or digits 01 through 99.

JA



ID Character = Disabled*#



NOTE

If you scan the label below, you must also scan two of the digits from the Digit Selection page.

JB



ID Character = XX

Code Identifier

A code identifier may optionally be transmitted with the message. This option is provided so a host computer can identify the type of bar code scanned, as well as the encoded information.

Scan Option FA to disable the code identifier.

FA  Disable Code ID # *

Scan Option FB to enable the code identifier.

FB  Enable Code ID

The table below shows the default code-identifier character assignments. These can be changed using the procedure found in the Symbology Identifier Section.

Table 4. Code Identifier Characters

SYMBOLGY	CODE IDENTIFIER
Code 39	a
Code Interleaved 2 of 5	b
Code Standard 2 of 5	c
UPC/EAN/JAN	d
Code 128	f
Codabar	h

Preamble or Postamble Selection

Preambles and Postambles are composed of up to four ASCII characters. Each ASCII character is encoded as two hexadecimal numbers. Use the Hexadecimal Conversion Table in Appendix A to look up the hexadecimal equivalent.



NOTE

If you select a Preamble or a Postamble you must scan four ASCII characters, even if the Preamble or Postamble is less than four characters in length. This is done by scanning in null (NUL) characters for the additional characters. For example, if your Preamble is "AB" (in ASCII code), scan A, then B, then two null characters, or 4,1, 4,2 0,0 0,0 hexadecimal.

Preamble

A Preamble is a string of characters that prefixes a message that is transmitted to the host. The sequence and number of characters in a Preamble is determined by the type of host system. Although not all systems require a Preamble, those which do will only receive messages with the correct Preamble. The maximum preamble length is four characters.

KA



Preamble = None*#

KB



Enter Preamble

IMPORTANT

Scan Enter Preamble to enter a Preamble, then refer to the Hexadecimal Table in Appendix A.

Postamble

A Postamble is similar to a Preamble, except that it appended to the message which is transmitted to the host. Its maximum length is also four characters.

LA



Postamble = None*#

LB



Enter Postamble

IMPORTANT

Scan Enter Postamble to enter a Postamble, then refer to the Hexadecimal Table in Appendix A.

Serial Commands

General Serial Command Format

Serial Commands are only accepted by the PSC scanner when in serial communications mode.

Serial commands take the form: **STX ESC LT1 LT2 <optional parameters>ETX** (Note: **STX = ^B; ETX = ^C**)

STX, ESC, and ETX are ASCII codes whose values are 02H, 1BH, and 03H, respectively. LT1 and LT2 are uppercase ASCII letters (commercial A and @ are the same as those printed in earlier sections of this manual under their corresponding menu bar code labels). The ESC code that follows the STX code identifies this as a command. Some commands require parameters such as minimum and maximum code lengths, and strings of hexadecimal characters. When parameters are required by the command, they immediately follow LT2. There are never spaces within serial commands.

ACK/NAK

The scanner provides ACK/NAK protocol during serial programming in order to provide feedback to the host computer which is programming the scanner.

ACK/NAK protocol provides two vital functions. First, it provides the host with positive acknowledgment that its commands are being accepted and acted upon. Second, and perhaps more important, it ensures that the host will not issue commands to the scanner more quickly than the scanner can process them. For example, every time the scanner receives a correct command, it modifies its internal EEPROM, a function that takes about one second. At 9600 baud, the host can easily issue commands to the scanner faster than they can be processed. If after issuing each command the host waits to receive an ACK or NAK code before issuing the next command, the scanner cannot be overrun. If XON/XOFF or CTS/RTS Protocol is being used, the scanner cannot be overrun by programming commands. However, the host is not provided with feedback as to the outcome of its commands.

The ACK/NAK protocol is quite simple. Whenever the scanner receives a correctly formatted command, it sends a confirmation message followed by an ACK (06H) code.

Beeper Off CR-LF Ack

If the scanner receives an unknown or improperly formatted code, or if the required parameters are missing or out-of-range, it sends a NAK (15H) Code.

Command	Function
STX ESC PC ETX	Enable I 2 of 5 with check digit
STX ESC PD12 ETX	Set I 2 of 5 minimum length to 12
STX ESC PE14 ETX	Set I 2 of 5 maximum length to 12
STX ESC KB31323334 ETX	Set Preamble to '1234'
STX ESC LB61626364	Set Postamble to 'abcd'

Serial Commands to Use with Caution

Some of the commands in this manual should not be used as serial commands because of the consequences they produce. All PSC scanners use the same hardware components to implement both serial communication and wand emulation. This means that all serial communication functions are disabled during wand emulation, and vice versa. Because of this, issuing any of the commands in Table 5 causes the scanner to enter its Wand Emulation mode, thereby disabling serial communication.

CB	Wand Emulation, Code 39 Output
CC	Wand Emulation, Same Code Output

Furthermore, because the scanner acts upon a command and then sends ACK or NAK, neither or these codes will be transmitted in response to any of the above commands. In Table 5 only the command letters are listed; the complete command is prefixed with STX ESC, and suffixed with ETX. Because it is not possible to set (via serial command) two Wand Emulation parameters (emulation speed and polarity, for example), scanners to be used in Wand Emulation environments must be programmed by scanning labels from this manual.

Power Standby and Serial Commands

When the scanner is programmed for standby power operation (@B), the first character of the command is used to “wake-up” the scanner; it is not properly received by the scanner’s CPU. Therefore, when there is any possibility that the scanner is in standby mode, an extra space code should be transmitted before STX to ensure the scanner is “awake” before sending commands to it. If the scanner is not being operated in standby mode, the space has no effect on commands (space prefixed commands are properly decoded). Having sent the space code to “wake-up” the scanner, a 150 to 200 millisecond pause must be observed to allow the scanner’s CPU to complete its initialization tasks, during which time it is unable to accept serial commands before issuing the programming command. Failure to observe this delay causes the scanner to ignore the incoming command.

Communication Parameter Changes









All commands which affect serial communication are acted upon immediately. Therefore, when changing communication parameters (baud rate, word length, parity, etc.), the scanner will send the ACK Code, using the newly implemented communication parameters. There should be enough of a delay from the issuance of a communication parameter setup command for the properly programmed host computer to modify its internal parameters and correctly receive the ACK code sent by the scanner. This is due to the internal, one second delay required for the scanner to update its internal EEPROM.

Manual Scanning Interaction

The decoder firmware makes no attempt to resolve conflicts between serial programming commands and manually scanned menu labels. If you plan to scan menu labels from the PSC Operator’s Manual, do not attempt serial programming, and vice versa. Serial commands are given priority over pending menu labels. For example, if you scan the menu label SET I 2 of 5 MINIMUM LENGTH and the scanner is waiting for a two-digit, minimum length code when a serial command is issued, the serial command is acted upon and the pending manual command SET I 2 of 5 MINIMUM LENGTH is ignored.

Keyboard Wedge Parameters

Scan symbol CE to enable Keyboard Wedge mode. Next, select a terminal type by scanning the symbol CF for IBM PC-AT or PS/2 models 50/60/80; or symbol CG for PC-XT type terminals. Alternatively, you may scan just CF or CG to enable wedge mode and select a terminal type.

CE		Wedge Mode Enable @
ZA		Reset to Wedge Default Values
CF		PC-AT, PS/2 and 50/60/80@ — U.S.A.
CG		PC-XT — U.S.A.
CH		IBM 3151 — U.S.A.
CI		DEC VT220 — U.S.A.
CN		Macintosh
CP		IBM 3477 — U.S.A.

CT



IBM 319X – U.S.A.

CY



PS/2 Mode 57/25 — U.S.A.

C6



Unisys B-26

C8



Link 125

CV



PC-AT German Keyboard

CW



PC-AT French Keyboard

CX



PC-AT UK Keyboard

\B



PC-AT Belgian Keyboard

\C



PC-AT Swiss Keyboard

\D



PC-AT Danish Keyboard

\E		PC-AT Italian Keyboard
\F		PC-AT Spanish Keyboard
\G		PC-AT Swedish Keyboard
\H		PC-AT Portuguese Keyboard
\L		DEC VT 220/320/420 German Keyboard
\M		DEC VT 220/320/420 French Keyboard

In normal Wedge Mode, the scanner emulates the keyboard exactly. Should a scanned bar code label have alphabetic characters, they will be presented to the computer as if they had been typed at the keyboard. They will be affected by the Caps Lock key. If the scanned label has lower case alphabetic characters AND the Caps Lock key in ON, then the alphabetic characters will be presented as upper case.

With the Caps Lock key ON, the user may require that the scanned alphabetic characters are presented to the computer exactly as they are encoded in the label. This is accomplished by scanning EO – Shift Alphabetic Characters.

EO



Shift Alphabetic Characters

EP



Normal Alphabetic Characters*



NOTE

In some models of scanner, the wedge output is capable of two types. To enable primary or secondary keyboard modes, scan one of the next two labels.

CQ



Enable Primary Keyboard@

CR



Enable Secondary Keyboard



NOTE

In Wedge Mode, non-printable ASCII characters (00-31H) do not allow for an obvious translation to keycodes. There are two approaches to this issue – they are explained in Appendix A.

@Q



Enable Primary Function Key Table@

@R



Enable Secondary Function Key Table



NOTE

See Appendix A.

Symbologies

The PSC scanner is configured with Code 39, Code 128, UPC-A and UPC-E not expanded symbologies. The user has the ability to enable or disable any of the symbologies given below as well as UPC or EAN supplements, I 2 of 5 with check digit, and Code 39 modulo 43 check digit.

The bar codes that can be read by PSC's bar code scanners include:

Code 39	Code 93
Interleaved 2 of 5	Code 128
Standard 2 of 5	Codabar
UPC-A, UPC-E	Code 11
EAN/JAN	MSI/Plessey

The minimum label lengths are set to 1 character, except Code I 2 of 5, which is set to 14 characters; and Code S 2 of 5, which is set to 4 characters. The maximum label length for all symbologies is set to 32 characters. The user has the ability to set the minimum and maximum label lengths.

The symbol * indicates Default Parameter for serial mode. The symbol # indicates Default Parameters for Wand Emulation. The symbol @ indicates default parameters for Wedge Mode.



NOTE

It is recommended that the user disable those symbologies and parameters that are not being used.

UPC (A and E)

Scan Option QA to disable all UPC labels.

QA



Disable UPC (both A and E)

Option QB or Option QC enable both UPC-A and UPC-E. If UPC is enabled, any UPC label, with or without supplement, is read. The supplement is read if Option QB is selected, and it is ignored if Option QC is selected.

QB  **Enable UPC with 2 or 5 Digit Supplement Enabled**

QC  **Enable UPC with 2 or 5 Digit Supplement Disabled *#@**

Expanded UPC-E is disabled by scanning Option QH, or is enabled by scanning Option QI.

QH  **Disable Expanded UPC-E *#@**

QI  **Enable Expanded UPC-E**

Transmission of the first character in a UPC symbol (the number system character) is disabled by scanning Option QD or enabled by scanning Option QE.

QD  **Disable Transmission of Number System Digit**

QE  **Enable Transmission of Number System Digit *#@**

Transmission of the last character in a UPC symbol (the check digit) is disabled by scanning Option QF, or is enabled by scanning Option QG.

QF  Disable Transmission of Check Digit

QG  Enable Transmission of Check Digit *#

Scanning QJ causes UPC-A labels to be transmitted as EAN-13 labels. Scanning QK disables this feature.

QJ  Enable UPC to EAN Translation









QK  Disable UPC to EAN Translation *#@

QN  Disable second beep on Supplement decoded *

QO  Enable second beep on Supplement decoded

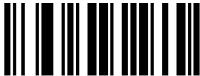
QP  Set supplement retry count (16 by default) range = 1-32

QR  Disable transmission of UPC-E check digit

QS		Enable transmission of UPC-E check digit*
QT		Disable transmission of UPC-E number system digit
QU		Enable transmission of UPC-E number system digit
QV		Disable UPC-E*
QW		Enable UPC-E independently with supplement
QX		Enable UPC-E independently without supplement*
Q0		Disable mandatory supplements*
Q1		Enable mandatory supplements



NOTE

QA to QG apply to UPC-A and UPC-E.

EAN/JAN

Scan Option RA to disable EAN/JAN (8 or 13 digit).

RA  Disable EAN/JAN (8 or 13 Digit) #@

Option RB or RC enables both EAN 8 digit and EAN 13 digit. If EAN/JAN is enabled, any EAN/JAN label, with or without supplement, is read. The supplement is read if Option RB is selected and is ignored if Option RC is selected.

RB  Enable EAN/JAN with 2 or 5 Digit Supplement enabled









RC  Enable EAN/JAN with 2 or 5 Digit *Supplement disabled

Transmission of the first character in an EAN/JAN symbol (the number system character) is disabled by scanning Option RD, or is enabled by scanning Option RE.

RD  Disable Transmission of Number System Digit

RE  Enable Transmission of Number System Digit *#@

Transmission of the last character in an EAN/JAN symbol (the check digit) is disabled by scanning Option RF, or is enabled by scanning Option RG.

RF		Disable Transmission of Check Digit
RG		Enable Transmission of Check Digit *#@
RJ		Disable EAN-8 Transmission of check character
RK		Enable EAN-8 Transmission of check character*
RL		Disable EAN-8 Transmission of number system digit
RM		Enable EAN-8 Transmission of number system digit*
RN		Disable EAN-8 independently*
RO		Enable EAN-8 independently with supplement
RP		Enable EAN-8 independently without supplement

RQ



Disable EAN-8 special 5 character (0's) preamble

RR



Enable EAN-8 special 5 character (0's) preamble



NOTE

RA to RG apply to both EAN-13 and EAN-8.

Code 39

To disable Code 39, scan Option OA.

OA



Disable Code 39

To enable Code 39, scan Option OB or OC. After enabling Code 39, make any additional required selections from Options OD through OG.

OB



Enable Standard Code 39*#@

OC



Enable Full ASCII Code 39

OD



Disable Modulo 43 Check Character*#@

OE



Enable Modulo 43 Check Character

The minimum length of Code 39 messages is set by scanning Option OH, followed by scanning two digits (01-32) from the Digit Selection page.

OH  Minimum Length (specified by two digits 01-32)

The maximum length of Code 39 messages is set by scanning Option OI, followed by scanning two digits (01-32) from the Digit Selection page. If the minimum and maximum values are set equal, only codes of that exact length are read.

OI  Maximum Length (specified by two digits 01-32)

The START and STOP characters in code 39 may either be transmitted or suppressed. Scan Option OF to suppress transmission of the START and STOP characters. Scan Option OG to enable transmission.

OF  Do Not XMIT START and STOP*#@

OG  Transmit START and STOP

The following are only valid if CHK CHAR is enabled.

OJ  Enable Transmission of Code 39 Modulo 43 Check Character

OK  Disable Transmission of Code 39 Modulo 43 Check Character *

Code 2 of 5 – Interleaved

Scan Option PA to disable Interleaved Code 2 of 5.

PA  Disable Interleaved Code 2 of 5*#@

Scan Option PB or PC to enable Interleaved Code 2 of 5.

PB  Enable Interleaved 2 of 5 without Check Digit

PC  Enable Interleaved 2 of 5 with Check Digit

The minimum length of Interleaved 2 of 5 messages is set by scanning Option PD, followed by scanning two digits (02-32) from the Digit Selection page. The value of the number you scan must be even.

PD  Minimum Length | 2 of 5 (specified by two digits 02-32)

The maximum length of Interleaved Code 2 of 5 is set by scanning Option PE, followed by scanning two digits (02-32) from the Digit Selection page. If the minimum and maximum values are set equal, only codes of that exact length are read. The minimum and maximum lengths must be even numbers.

PE  Maximum Length | 2 of 5 (specified by two digits 02-32)

Code 128

Scan Option TA to disable Code 128.



Scan Option TB to enable Code 128.



The minimum length of Code 128 messages is set by scanning Option TC, followed by scanning two digits (01-32) from the Digit Selection page.

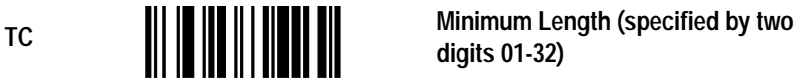

The maximum length of Code 128 messages is set by scanning Option TD, followed by scanning two digits (01-32) from the Digit Selection page. If the minimum and maximum values are set equal, only codes of that exact length are read.

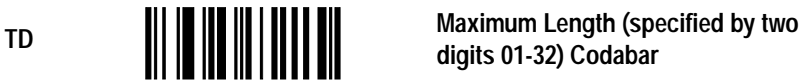

Scan Option VA to disable Codabar.



Scan Option VB to enable Codabar.



The minimum length of Codabar messages is set by scanning Option VE, followed by scanning two digits (01-32) from the Digit Selection page.

VE



Minimum Length (specified by two digits 01-32)

The maximum length of Codabar messages is set by scanning Option VF, followed by scanning two digits (01-32) from the Digit Selection page. If the minimum and maximum values are set equal, only codes of that exact length are read.

VF



Maximum Length (specified by two digits 0-32)

The transmission of the STOP/START Characters is enabled by scanning Option VD, or is suppressed by scanning Option VC.

VC



Disable Transmission *#@ of START/STOP character

VD



Enable Transmission of START/STOP Character

MSI/Plessey

Previous customization of other scanner features may have made MSI/Plessey unavailable in some scanners. Consult Customer Service for current capabilities or if you require a specific symbology.

PK



Enable MSI/PLESSEY

PL



Set Minimum Length, then scan two digits: 01-14 (see Digit Selection).

PM



Set Maximum Length, then scan two digits: 01-14 (see Digit Selection).

PJ



Disable MSI/PLESSEY

Code 11

Previous customization of other scanner features may have made Code 11 unavailable in some scanners. Consult Customer Service for current capabilities or if you require a specific symbology.

SB







Enable Code 11 with one check digit

SC





Enable Code 11 with two check digits

SF		Set Minimum Length, specified by two digits 01-32
SG		Set Maximum Length, specified by two digits 01-32
SE		Enable transmission of check digits
SD		Disable transmission of check digits
SA		Disable Code 11

Code 93

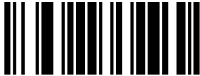
Previous customization of other scanner features may have made Code 93 unavailable in some scanners. Consult Customer Service for current capabilities or if you require a specific symbology.

UB		Enable Code 93
UC		Standard Code 93

UD



Enable Full ASCII Code 93

UE



Set Minimum Length, specified by
two digits 0-1-32

UA



Disable Code 93

16K

TF



Enable 16K Code

TE



Disable 16K Code

Digit Selection



0



1



2



3



4



5



6



7









8









9

Symbology Identifiers

Your PSC scanner can be programmed to add and/or change symbology identifiers which might be required to be transmitted with messages. This feature is provided to allow a host computer to recognize the type of bar code scanned, as well as the uncoded information. The symbology identifiers are selected by scanning the desired programming bar code symbol as defined below.

SYMBOL		FUNCTION
FA		Disable Transmission of Symbology Identifiers*
FB		Enable Transmission of Symbology Identifiers
FE		Set UPC-A Symbology Identifier
FF		Set UPC-E Symbology Identifier
FG		Set EAN-8 Symbology Identifier
FH		Set EAN-13 Symbology Identifier
FI		Set Code 128 Symbology Identifier

FJ		Set Code 39 Symbology Identifier
FK		Set I 2/5 Symbology Identifier
FL		Set S 2/5 Symbology Identifier
FM		Set Code 11 Symbology Identifier
FN		Set Code 93 Symbology Identifier
FO		Set Codabar Symbology Identifier
FP		Set MSI/Plessey Symbology Identifier

To change any single symbology identifier, scan the appropriate symbology identifier bar code symbol and then scan the four hexadecimal characters that represent the two bytes of the identifier. If you select a one character identifier, then scan zero (null) twice for the second character.

To find the hexadecimal values for the characters turn to the Hexadecimal Conversion Table. The procedure for selecting a symbology identifier is identical to the procedure for selecting Preambles and Postambles. The similar difference is that symbology identifiers are a maximum of two characters, not four.



NOTE

Scanning the ZA (Result to Default) programming symbol will set all symbology identifiers back to PSC defaults as given in Table I and disable the transmission of the symbology identifiers.

The FC programming symbol selects the symbology identifiers for use with ICL 9518/9520 cash registers.

FC  Programming Symbol

The FD programming symbol selects the symbology identifiers for use with ICL 9518/9520 cash registers as given in Table 5.

FD  Programming Symbol

Table 5. Symbology Identifiers

Symbology	ZA-PSC Default	PC-ICL 9518	CCD
UPC-A	d	A	A
UPC-E	d	E	C
EAN-8	d	FF	B
EAN-13	d	F	A
Code 128	f	I	Y
Code 39	a	I	Y
Interleaved 2/5	b	I	Z
Standard 2/5	c	I	Y
Code 11	e	I	Y
Code 93	g	I	Y
Codabar (NW7)	h	I	X
MSI/Plessey	p	I	Y

Wand Emulation Parameters

Select Code Type

Scan Option CC if you intend to operate the scanner in Same Code Wand Emulation mode. If you want the label to be transmitted in Code 39 scan Option CB.

CC  Same Code Wand # Emulation

CB  Wand Emulation (Code 39, Full ASCII)

Bar Code Polarity

Selected Option WA or WB.

WA  Black High#

WB  White High

WC  Black High, Quiescent High

Transmission Rate

Select the fastest speed your decoder will accept for best overall performance by scanning one of the following labels.

YA  5 inches per second

YB



10 inches per second#

YC



15 inches per second

YD



20 inches per second

YE



30 inches per second

YF



50 inches per second

YG



70 inches per second

Data Synchronization

Your PSC scanner can be prepared to synchronize the transmission of scanned data to the timing sequence some terminals require to properly receive the data. This relationship is diagrammed in Figure 2.

Figure 2. Timing Sequence Diagram

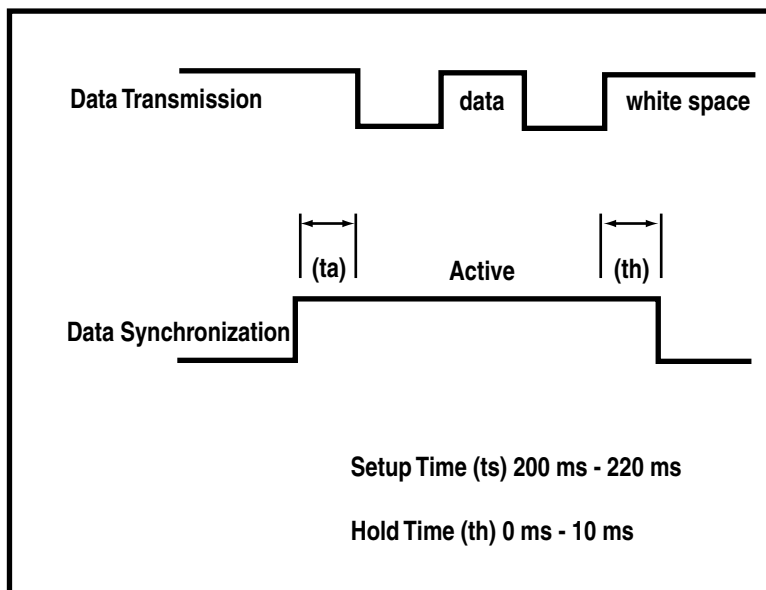

RTS output is used for the data synchronization signal. Scan XD to enable the data synchronization signal. Scan Option XC to disable Data Synchronization.

XC  Disable Data # Synchronization

XD  Enable Data Synchronization

Polarity may be selected as either active high or low by scanning XE (high) or XF (low).

XE



Active # Polarity High

XF



Active Polarity Low

Memory Module

The Memory Module option is a factory installed feature that is requested at time of order. The Memory Module option allows the 5300 series scanner to store decoded labels in an internal battery backed up RAM. The stored buffered labels can then be transmitted some time later. The user may also choose an interlabel transmission delay in cases where the transmission rate of the buffered decoded label is faster than the receiving equipment.

Switching to the Memory Module mode is achieved by scanning the Enable Memory Module symbol. The Memory Module is cleared every time Memory Module is enabled. While in Memory Module mode, the scanner will store in its internal memory all scanned bar code labels.

The user can transmit the stored labels by scanning the Send Memory Module symbol. When the transmission rate is faster than the receiving equipment, the user can program a delay that will occur after each label. The delay is programmed by scanning the Interlabel Delay symbol (see the Intercharacter Delay page of the Setup Parameters section), followed by two digits (see Digit Selection page) to set the delay duration. The allowable range of values is 00 to 99, where 99 corresponds to a delay of 9.9 seconds.

In order to restore the scanner to normal operation, the user needs to scan the Disable Memory Module label. Also the user may clear the contents of the Memory Module by scanning the Clear Memory Module symbol or by disabling and enabling Memory Module. Stored labels are cleared whenever Memory Module is enabled.



NOTE





The stored data in the Memory Module cannot be transmitted through the Wand Emulation output.



CAUTION

The Memory Module feature is to be used only with the Memory Module mode. When used with scanners without this optional mode, programmed instructions will be damaged.

Setup

NC		Disable Memory Module*#
ND		Enable Memory Module
MM		Enable automatic switch to memory module
MN		Disable automatic switch to memory module *



NOTE

If enabled, this mode intelligently switches from POS mode to Memory Module mode based on power source.

ZK		Send Memory Module
ZL		Clear Memory Module

Marker Beam

The Marker Beam feature provides the user with a spotter beam for improved aiming at distant bar code labels and/or in extremely bright environments. You may also find a Marker Beam useful when scanning through showcase glass or bar code menus with labels in close proximity. This feature is available in all scanners without factory authorization.

To activate the Marker Beam, the user must also program the duration of the Marker Beam. First, the symbol Enable Marker Beam is scanned and then followed by scanning one digit symbol from the Digit Selections table. Each digit symbol represents the desired time duration of the Marker Beam in milliseconds.

To deactivate the Marker Beam, the user must scan the Disable Marker Beam symbol. For successful programming, the user must hold the trigger down for two seconds after scanning.

NQ  Enable Marker Beam

NP  Disable Marker Beam



50 MS



100 MS



150 MS



200 MS



250 MS



300 ms



350 MS



400 MS



450 MS



500 MS

Scanner Labeling

The PSC Laser Scanners use a low-power, visible laser diode. As with any bright light source, such as the sun, the user should avoid staring directly into the light beam.



WARNING

Use of controls, adjustments, or performance of procedures other than those specified herein may result in hazardous visible light exposure.

Service and Warranty

PSC provides service for its bar code products at the service center located at its manufacturing facility in Eugene, Oregon. The specific warranty language for the bar code scanner is contained in the next section of this manual. Several service plans are available for the products:

All products carry a minimum one year warranty from date of purchase.

- A warranty extension program is available at a nominal annual fee.
- Factory service is available for out-of-warranty products by requesting a Return Material Authorization (RMA) for the product from our Repair Service Group. They can be contacted by calling:

1-800-547-2507

within the continental United States, Canada, or Mexico)
or 1-541-683-5700 (elsewhere)

Should you call to request an RMA, have the following information available:

- Model Number
- Serial Number
- Date of Manufacture
- Description of Problem
- Purchase Order Number

The PSC Fax number is:

Fax: 541 686-1702

Maintenance

PSC Scanners are designed to provide trouble-free operation throughout their lives. They contain no components that require periodic maintenance. Optimum performance may be ensured by following the preventive maintenance procedures suggested below. If scanning performance declines, please follow these procedures.

Cleaning

A dirty scan window can impair scanning performance. When the window appears to be dirty or smeared, clean it by wiping with a slightly damp cloth or facial tissue. Water or a suitable cleaning solution such as Windex™ may be used on the cloth. The plastic case of your scanner can also be cleaned in this manner.



NOTE

Never use solvents (e.g., alcohol) on the enclosure; they may damage the finish of the scanner.

Inspection

Periodically inspect scanner cords and cables for wear and other signs of damage which may interfere with the proper operation of the unit. A badly worn cord or cable should be replaced immediately. Replacement cords and cables can be obtained by contacting your PSC Customer Service Representative.

Routinely examine scanners for signs of damage. A badly dented enclosure may cause interference with internal components resulting in damage to, or malfunction of the unit. Units with damage to the enclosure should be returned to the factory for repair. Please refer to Service and Warranty Section.

NOTES

Appendix A

Hexadecimal Conversion Table

To use the conversion table:

1. Find each ASCII character in the tables on the following pages and locate the corresponding bold hexadecimal-equivalent character in the top row and in the left column of the table. Notice, for example, that the ASCII character "Q" is represented by the hexadecimal numbers 5 (top) and 1 (left).
2. Scan the bar code symbols that correspond to the hexadecimal-equivalent characters. First scan the bar code symbol that corresponds to the bold hex character at the top. *Then scan the bar code symbol that corresponds to the bold hex character at the left.*

For example, for the ASCII character "Q," first scan the bar code symbol labeled 5; then scan the bar code symbol labeled 1. If your preamble or postamble contains an "N", first scan 4 and then E.

3. Repeat this procedure for each ASCII character you wish to enter.

Hexadecimal Conversion Table

Part A



	0	1	2	3
0	NUL	DLE	SP	0
1	SOH	DC1	!	1
2	STX	DC2	"	2
3	ETX	DC3	#	3
4	EOT	DC4	\$	4
5	ENQ	NAK	%	5
6	ACK	SYN	&	6
7	BEL	ETB	'	7
8	BS	CAN	(8
9	HT	EM)	9
A	LF	SUB	*	:
B	VT	ESC	++	;
C	FF	FS	,	<
D	CR	GS	-	=
E	SO	RS	.	>
F	SI	US	/	?

Hexadecimal Conversion Table

Part B

	4	5	6	7
0	@	P	'	p
1	A	Q	a	q
2	B	R	b	r
3	C	S	c	s
4	D	T	d	t
5	E	U	e	u
6	F	V	f	v
7	G	W	g	w
8	H	X	h	x
9	I	Y	i	y
A	J	Z	j	z
B	K	[k	{
C	L	\	l	
D	M]	m	}
E	N	^	n	~
F	O	_	o	DEL



8



9



A



B



C



D



E



F

Primary Function Key Table

ASCII	HEX	FUNCTION
NUL	00	CONTROL @
SOH	01	CONTROL A
STX	02	CONTROL B
ETX	03	CONTROL C
EOT	04	CONTROL D
ENQ	05	CONTROL E
ACK	06	CONTROL F
BEL	07	CONTROL G
BS	08	CONTROL H
HT	09	CONTROL I
LF	0A	CONTROL J
VT	0B	CONTROL K
FF	0C	CONTROL L
CR	0D	RETURN KEY
SO	0E	CONTROL N
SI	0F	CONTROL O
DLE	10	CONTROL P
DC1	11	CONTROL Q
DC2	12	CONTROL R
DC3	13	CONTROL S
DC4	14	CONTROL T
NAK	15	CONTROL U
SYN	16	CONTROL V
ETB	17	CONTROL W
CAN	18	CONTROL X
EM	19	CONTROL Y
SUB	1A	CONTROL Z
ESC	1B	CONTROL [
FS	1C	CONTROL \
GS	1D	CONTROL]
RS	1E	CONTROL ^
US	1F	CONTROL &

Secondary Function Key Tables

PC/AT, PC/XT, IBM 3151, and IBM PS/2 Model 57/25

ASCII	HEX	FUNCTION
NUL	00	ESCAPE
SOH	01	NEW LINE ENTER
STX	02	ALT left side Make
ETX	03	ALT left side Break
EOT	04	CTRL left side Make
ENQ	05	CTRL left side Break
ACK	06	ENTER right keypad (NOTE 1)
BEL	07	Cursor up (inner keypad)
BS	08	Cursor dn (inner keypad)
HT	09	Cursor left (inner keypad)
LF	0A	Cursor right (inner keypad)
VT	0B	TAB FWD
FF	0C	DEL (inner keypad)
CR	0D	NEW LINE ENTER
SO	0E	INS (inner keypad)
SI	0F	Page Up (inner keypad)
DLE	10	Page Dn (inner keypad)
DC1	11	HOME (inner keypad)
DC2	12	PRINT SCREEN
DC3	13	BACKSPACE
DC4	14	BACKFIELD (Shift TAB)
NAK	15	SCROLL LOCK
SYN	16	F1
ETB	17	F2
CAN	18	F3
EM	19	F4
SUB	1A	F5
ESC	1B	F6
FS	1C	F7
GS	1D	F8
RS	1E	F9
US	1F	10

NOTE 1: [+] right keypad for the PC/XT and IBM PS/2 Model 57/25.

Secondary Function Key Tables

IBM 3171/3181/3191 and IBM 3477

ASCII	HEX	FUNCTION
NUL	00	ESCAPE
SOH	01	ON LINE ENTER (Make/Break)
STX	02	ALT left side Make
ETX	03	ALT left side Break
EOT	04	ON LINE ENTER (Make only)
ENQ	05	FIELD EXIT (Make only)
ACK	06	ENTER right keypad
BEL	07	Cursor up (inner keypad)
BS	08	Cursor dn (inner keypad)
HT	09	Cursor left (inner keypad)
LF	0A	Cursor right (inner keypad)
VT	0B	TAB FWD
FF	0C	DEL (inner keypad)
CR	0D	FIELD EXIT (Make/Break)
SO	0E	INS (inner keypad)
SI	0F	Page Up (inner keypad)
DLE	10	Page Dn (inner keypad)
DC1	11	HOME (inner keypad)
DC2	12	PRINT SCREEN
DC3	13	BACKSPACE
DC4	14	BACKFIELD (Shift TAB)
NAK	15	SCROLL LOCK
SYN	16	F1
ETB	17	F2
CAN	18	F3
EM	19	F4
SUB	1A	F5
ESC	1B	F6
FS	1C	F7
GS	1D	F8
RS	1E	F9
US	1F	F10

VT220/320/420

ASCII	HEX	FUNCTION
NUL	00	'~ (terminal may be configured for ESCAPE)
SOH	01	NEW LINE ENTER – Return
STX	02	ALT Make
ETX	03	ALT Break
EOT	04	CTRL Make
ENQ	05	CTRL Break
ACK	06	ENTER – right side keypad
BEL	07	Cursor up
BS	08	Cursor dn
HT	09	Cursor left
LF	0A	Cursor right
VT	0B	TAB FWD
FF	0C	Remove
CR	0D	Return (Main keypad)
SO	0E	Insert Here
SI	0F	Prev
DLE	10	Next
DC1	11	PF1
DC2	12	PF2
DC3	13	BACKSPACE
DC4	14	PF3
NAK	15	PF4
SYN	16	F1
ETB	17	F2
CAN	18	F3
EM	19	F4
SUB	1A	F5
ESC	1B	F6
FS	1C	F7
GS	1D	F8
RS	1E	F9
US	1F	F10

Apple Macintosh

ASCII	HEX	FUNCTION
NUL	00	NUL
SOH	01	F1
STX	02	F2
ETX	03	F3
EOT	04	F4
ENQ	05	F5
ACK	06	F6
BEL	07	F7
BS	08	F8
HT	09	TAB
LF	0A	Enter
VT	0B	Page Up
FF	0C	Page Down
CR	0D	RETURN
SO	0E	F9
SI	0F	F10
DLE	10	Command On
DC1	11	Delete
DC2	12	Command Off
DC3	13	Left Arrow
DC4	14	Right Arrow
NAK	15	Down Arrow
SYN	16	Up Arrow
ETB	17	Home
CAN	18	End
EM	19	Shift On
SUB	1A	Shift Off
ESC	1B	Esc
FS	1C	Control On
GS	1D	Control Off
RS	1E	Option (Alt) On
US	1F	Option (Alt) Off



DECLARATION OF CONFORMITY

PSC hereby declares that the Equipment specified below has been tested and found compliant to the following Directives and Standards:

Directives: EMC
Low Voltage

Standards: EN
EN 50082-1
EN 60950

Equipment Type: Handheld Laser
Bar Code Scanners

Product: Keyboard Wedge/
Wand Emulation Interface

A handwritten signature in black ink, appearing to read 'Charles W. Vanlue'.

Charles W. Vanlue
Director, Corporate Quality
PSC, Inc.
959 Terry Street
Eugene, OR 97402
U.S.A.

A handwritten signature in black ink, appearing to read 'Nigel Davis'.

Nigel Davis
Vice President
Europe, Middle East & Africa
PSC Bar Code Ltd.
Axis 3, Rhodes Way
Watford, England
WD24YW
UK



Part No. 06656 • Rev C (03/00)

Asia Pacific

PSC Hong Kong
Hong Kong
Telephone: [852]-2-584-6210
Fax: [852]-2-521-0291

Australia

PSC Asia Pacific Pty Ltd.
North Ryde, Australia
Telephone: [61] 0 (2) 9878 8999
Fax: [61] 0 (2) 9878 8688

France

PSC Sarl
LES ULIS Cedex, France
Telephone: [33].01.64.86.71.00
Fax: [33].01.64 46.72.44

Germany

PSC GmbH
Darmstadt, Germany
Telephone: + 49 (0) 61 51/93 58-0
Fax: + 49 (0) 61 51/93 58 58

Italy

PSC S.r.l.
Vimercate (MI), Italy
Telephone: [39] (0) 39/62903.1
Fax: [39] (0) 39/685496

Japan

PSC Japan K.K.
Shinagawa-ku, Tokyo, Japan
Telephone: 81 (0)3 3491 6761
Fax: 81 (0)3 3491 6656

Latin America

PSC S.A., INC.
Miami, Florida, USA
Telephone: (305) 539-0111
Fax: (305) 539-0206

United Kingdom

PSC Bar Code Ltd.
Watford, England
Telephone: 44 (0) 1923 809500
Fax: 44 (0) 1923 809 505

Corporate Headquarters

675 Basket Road
Webster, NY 14580-9787
Telephone: (716) 265-1600
Toll Free: (800) 828-6489
Fax: (716) 265-6400

PSC[®]www.pscnet.com**PSC Scanning, Inc.**

959 Terry Street
Eugene, OR 97402-9150
Telephone: (541) 683-5700
Toll Free: (800) 547-2507
Fax: (541) 686-1702



Printed on recycled paper

