



## OPERATION MANUAL



***T-6***

---



## **Dear Customers!**

We would like to congratulate you on your decision to join the Tana Water family by purchasing T-6 - the world's most advanced water bar of its type.

T-6 comes to your home after years of research and development, and after passing through the hands of some of the best designers in the world.

The filtration and purification system used on T-6 an international patent, ensuring a stellar drinking experience for the entire family by providing the choice of unlimited hot or cold water, sparklingly clear, refreshing and healthy.

Tana Water is one of the worlds largest and most experienced company specializing in the production, development, service and marketing of drinking-water filtration and purification systems. Tana Water's computerized service system is among the most advanced in the market, providing our clients with generous and professional service.

Sincerely,  
Tana Water

## **Manufacturer's Certificate of Compliance**

Tana Water Company hereby confirms that the T-6 appliance manufactured by Tana Water complies with the requirements of Standard no. 1505 for Water Quality and with the requirements of Standard: CE, UL and International standards.

All electrical components and materials used in the manufacture of these dispensers comply with international standards for use in a food / drinking water environment. The dispenser's chemical purification process absorbs chlorine (Class I, at least 75%), and provides Class B microbe purification against volatile organic compounds (VOCs).

Tana Water and its quality assurance system have been certified according to the international standard ISO 9001:2000.

Avinoam Kfir  
Quality Director



CONTENTS:

<b>.1GENERAL VIEW</b> .....	<b>4</b>
<b>.2TECHNICAL FEATURES</b> .....	<b>5</b>
<b>.3OPERATION PANEL</b> .....	<b>6</b>
<b>.4INSTALLATION</b> .....	<b>7</b>
4.1GENERAL INSTRUCTIONS .....	7
4.2WATER SOURCE CONNECTION .....	7
4.3PREPARATION FOR OPERATION.....	7
<b>.5OPERATION</b> .....	<b>9</b>
5.1WATER DISPENSING.....	9
5.2SYSTEM MODES .....	10
5.3MENU FUNCTION.....	11
<b>.6MAINTENANCE AND REPLACEMENT</b> .....	<b>16</b>
6.1DROP COLLECTOR EMPTYING.....	16
6.2REPLACEMENT.....	16
6.3COUNTERS DISPLAY .....	16
6.4FILTER REPLACEMENT .....	17
6.5UV LAMP REPLACEMENT .....	17
<b>.7CLEANING THE APPLIANCE</b> .....	<b>18</b>
<b>.8WEEKENDS / HOLIDAYS / VACATIONS</b> .....	<b>18</b>
<b>.9WARNING * SAFETY * SERVICE</b> .....	<b>18</b>
<b>.10TROUBLESHOOTING</b> .....	<b>20</b>
10.1CUSTOMER.....	20
10.2TECHNICIAN.....	21
<b>.11ELECTRIC DIAGRAM</b> .....	<b>24</b>
<b>12PARTS LIST</b> .....	<b>25</b>
12.1EXPLODED VIEW .....	25
12.2PARTS CATALOGUE .....	27

## 1. General View

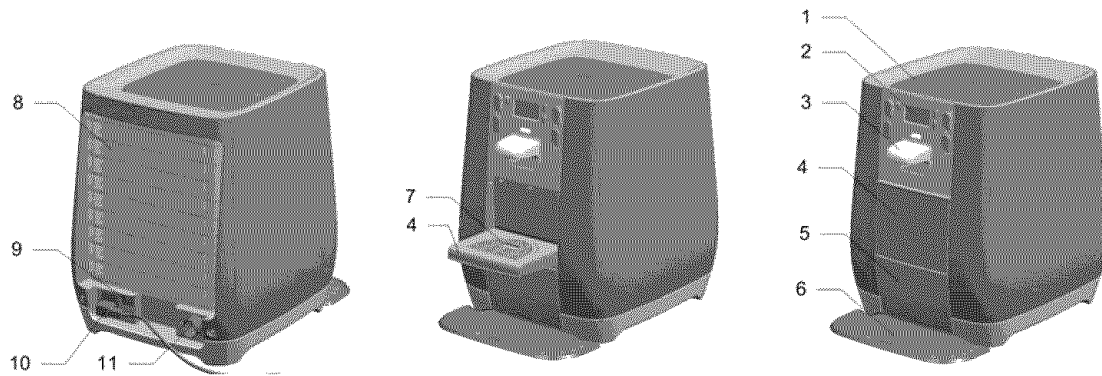

1. Top Deco Cover
2. Operation Panel with digital display screen
3. Water Spout
4. Folding tray
5. Drip tray
6. Bottom Deco Tray

7. Folding Tray Grid
8. Condenser
9. Heating System Switch
10. Power cable plug
11. Water Inlet port

## 2. Technical features

No	Features	Data	
		230 volts	115 volts
	<b>Power supply</b>		
1.	<b>Electricity</b> Voltage Frequency Cooling Power Consumption* Heating Power Consumption Current Consumption	230V, 1 Phase 50 Hz 100 Watts 1800Watts 8.5 A	115V, 1 Phase 60 Hz 100 Watts 950Watts 9.5 A
2.	<b>Cooling System</b> Tank Volume Cooling Capacity** Cold Water output*** Cooling Temperature Range	1.6 liters 125 W 40 glasses/hour 5 -16°C	54 oz 135 W 40 glasses/hour 40 - 60°F
3.	<b>Heating Systems</b> Tank Volume Hot Water output*** Heating Temperature Range	1.4 liters 80 glasses/hour 92-96 °C	47 oz 50 glasses/hour 198- 205 °F
4.	<b>Purification</b> UV Lamp Activated Carbon Filter Anti Scaling Agent	11 Watts 0.6 micron. nominal Polyphosphates	11 Watts 0.6 micron nominal Polyphosphates
5.	<b>Water Inlet Pressure</b> Min Max	1.5 ATM 6 ATM	21 PSI 85 PSI
6.	<b>Unit Main Sizes</b> Height Depth Width	35 cm 35 cm 29 cm	13.7 “ 13.7 “ 11.4 ”
7.	<b>Weight (Dry)</b>	14 kg	30.8 lb

Maximum ambient temperature: +32 °C/90°F

\* - ASHRAE check point condition, Evaporating temp. = +7.2 °C/ 45°F,

\*\* - ASHRAE check point condition, Evaporating temp. = -5 °C/ 23 °F,

\*\*\* Water output capacity is measured in an environmental temperature that is no greater than +25 °C/ 77°F, with the temperature of the water in the water system being no greater than + 22 °C/ 72°F,

\*\*\*\* If the pressure is greater, a pressure regulator/reducer must be installed before the appliance. In sites prone to water shock, we recommend that protection - in the form of a Water Block – be installed.

### 3. Operation panel

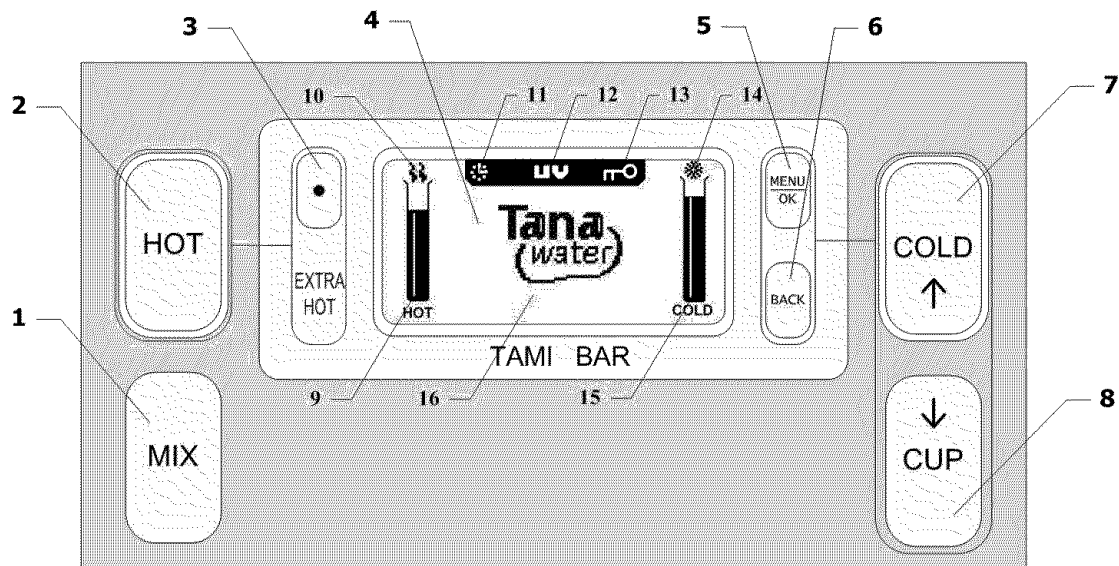

1	"MIX"	Mixed water dispensing key (Predefined dosage and temperature)
2	"HOT"	Hot water dispensing key
3	"EH"	Extra Hot Key
4	DISPLY	Graphic Display
5	"MENU/ OK"	Enter Menu Functions & OK key
6	"BACK"	Back key (return to previous menu)
7	"COLD"	Cold water dispensing key Scroll up at menu functions
8	"CUP"	Predefined dosage and temperature water dispensing key Scroll down at menu functions
9	HOT WATER TEMP.	Hot water temperature indication bar
10	"vapor" symbol	Heating system operation indication Alight when heater ON
11	"clock" symbol	Timer function indication Appears when automatic energy saving mode ON
12	UV	UV system indication
13	"key" symbol	Child protection indication Appears when child protection mode ON
14	"snow" symbol	Cooling system operation indication Alight when compressor ON
15	COLD WATER TEMP.	Cold water temperature indication bar

## 4. Installation

### 4.1 General instructions

The T-6 should be installed in **shady** and **ventilated** place, **away from heat** and on **hard leveled surface**. The distance from the back wall should be as far as **10 cm (4")** and with sufficient **space** on both sides. Only TANA approved fittings should be used.

### 4.2 Water source connection

Make sure the water source is **close** to the unit (not more than 5 meters (16 feet).

**Water pressure** has to be between 2 to 6 (30-90 psi) BAR.

The **ball valve** must be connected to the water line before the unit. Make sure that this valve is **easily reachable** for maintenance

### 4.3 Preparation for operation

1. Remove the plastic packaging of the *filter cartridges* and make sure it is in good condition; then insert it inside the filter housing (see drawing on page 17)
2. Check that the *heating systems switch* (*pos.9-general view*) is on the "off" position ("0").
3. Plug the unit to the eclectic power.  
Once the unit is plugged in, the control system performs self check:
  - Sounds one BEEP
  - After 5-7 seconds the system will BEEP again twice and system enter to semi-automatic installation procedure.

#### Note:

\* The unit leaves factory in "SHIPPING MODE" which requires to proceed full installation procedure after first unit Plug IN. This is to insure proper water tanks filling and cleaning.

#### **\*\*Boiling temperature set**

If unit installed in a mountings place (higher then 400 m then sea level), the boiling temperature should be set accordingly.

Skip boiling temperature set if not needed.

4. The unit will not start to operate until "INSTALLATION COMPLETED" is confirmed by pressing "OK" key at the end of installation procedure.

Installation flow chart.

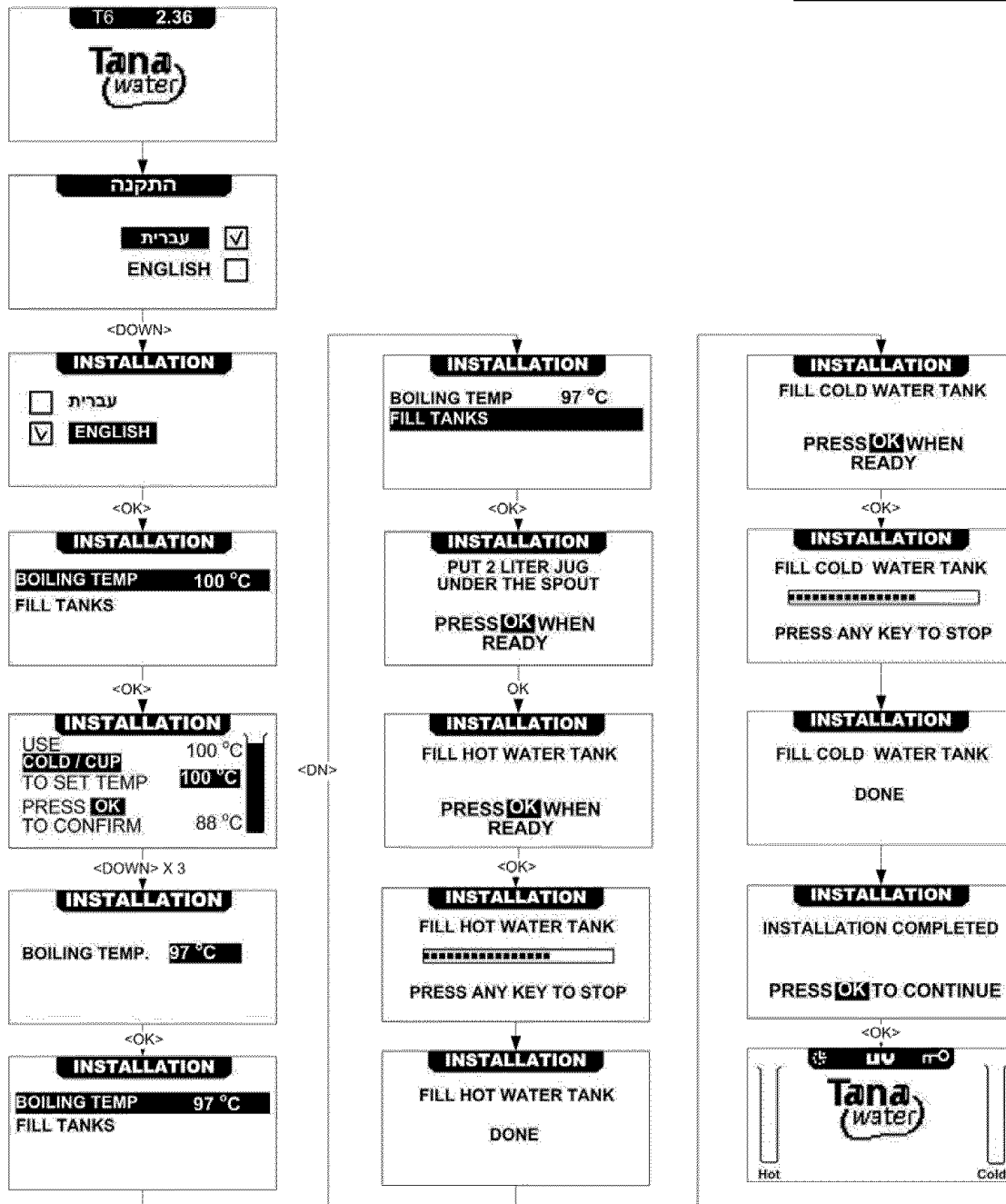

Pay attention (for US market):  
During installation procedure the temperature appears in Celsius degree only.

- ⇒ Press the hot switch on the back panel on the “ON” position (“1”). The heating system will start working after 30 second.
- ⇒ Cooling system will automatically start operating after 3 min delay.
- ⇒ Check water temperatures (hot and cold).
- ⇒ Make sure that there are no water leaks.

## 5. OPERATION

### 5.1 Water Dispensing

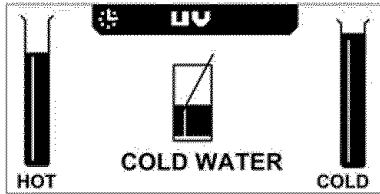

#### Cold water dispensing

Press "COLD" key for continues cold water dispensing.  
"Filling glass" icon appears during water dispensing.

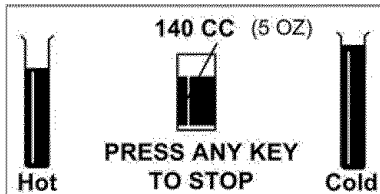

#### Predefined cup cold water dispensing

Press "CUP" key for predefined cold water dispensing.  
"Glass" icon and dosage appears during water dispensing.  
To stop water dispensing press any key.  
Set dosage see paragraph 5.3

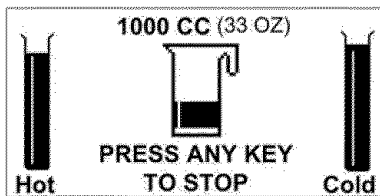

#### Predefined jug cold water dispensing

To dispense big quantity of cold water first press "COLD" key and then press "CUP" key simultaneously.  
"Jug" icon and dosage appears during water dispensing.  
To stop water dispensing press any key.  
Dosage set at factory.

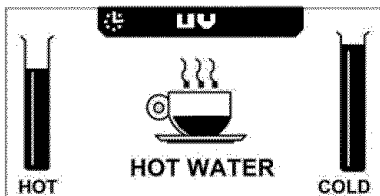

#### Continues hot water dispensing

Press "HOT" key for continues hot water dispensing.  
"Filling cup" icon appears during water dispensing.  
**SAFETY NOTICE: please ensure hands are removed from the cup or glass when dispensing boiling water and use care when picking up the cup.**



#### Predefined hot water dispensing (cup)

Press "HOT" key momentary for predefined dose hot water dispensing." Hot cup" icon appears during water dispensing.  
To stop water dispensing press any key.  
Set dosage see paragraph 5.3  
**NOTE: this function is not available if "Child protection" mode is active.**

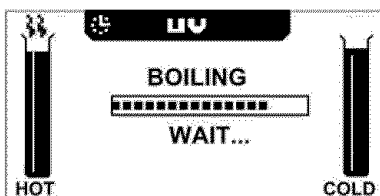

#### Extra Hot water dispensing

Press "Extra HOT" key to heat water up to near boiling temperature.  
Wait until water achieves desired temperature, then press "HOT" key to dispense.

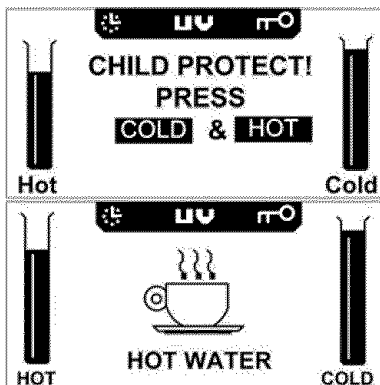

#### Hot water dispensing when child protection ON

When system is in "child protection mode" press "HOT" key and then "COLD" key simultaneously.

Note: Hot water dispensing continue until "HOT" key is pressed.



**Predefined room temperature water dispensing**

Press "MIX" key for predefined room temperature water dispensing.  
 "Glass" icon and dosage appears during water dispensing.  
 To stop water dispensing press any key.  
 Set dosage and temperature see paragraph 5.3

**5.2 System modes**

There are three main system modes:

	<p><b>I. Normal Mode</b></p> <p>In this Mode Cold/Hot/Mix/Cup dispensing allowed</p>
	<p><b>II. Energy Saving Mode</b></p> <p>In "Energy Saving" mode, you can use Cold//Mix/Cup functions by pressing "MIX" or "HOT" key.              Hot water dispensing will begin when heater achieves 85 C.              If "Extra hot" key is pressed water will be heated until boiling temperature.              System enters "Energy saving mode" automatically.              "Energy saving Mode" definition parameters set see paragraph 5.3</p>
	<p><b>III. Power Down Mode</b></p> <p>In Power Down Mode cooling and heating systems are not operating.              System enters Power Down mode automatically after predefined period or using Menu function "OFF":</p> <p><b>MAIN MENU</b> → <b>OFF</b></p> <p>To exit Power Down mode press any dispensing key.              Note: The clock continues functioning in Power Done mode.</p>

### 5.3 Menu function

#### 5.3.1. Clock and day set

To set clock enter into “clock” sub-menu



<p><b>CLOCK</b></p> <p><b>CLOCK SET 12 : 00</b></p> <p><b>DAY SET SUN</b></p>	<p>On display appears exist clock and day data. To choose clock or day use scroll keys “COLD”&amp;”CUP”. Press “OK” to enter to the set menu.</p>
<p><b>CLOCK</b></p> <p><b>CLOCK SET 12 : 00 --</b></p>	<p>Hour set. To change hour use scroll keys “COLD”&amp;”CUP”. Press “OK” to confirm.</p>
<p><b>CLOCK</b></p> <p><b>CLOCK SET 12 : 00 --</b></p>	<p>Minutes set. To change minute use scroll keys “COLD”&amp;”CUP”. Press “OK” to confirm.</p>
<p><b>CLOCK</b></p> <p><b>CLOCK SET 12 : 00 --</b></p>	<p>24 hours - AM/PM clock mode set. To change SET use scroll keys “COLD”&amp;”CUP”. Press “OK” to confirm. When symbol “- - “ appears, the 24 hours clock mode is activated.</p>
<p><b>CLOCK</b></p> <p><b>DAY SET SUN</b></p>	<p>Day set. To change SET use scroll keys “COLD”&amp;”CUP”. Press “OK” to confirm.</p>

### 5.3.2. Wake up timer set.

There are two independent timers, which “wake up” the heating system from “sleep mode”. To set wake up timer enter into “wake up” sub-menu

**MAIN MENU** → **TIME & DATE** → **WAKE UP**

WAKE UP	
WAKE UP 1	07:00
WAKE UP 2	OFF

WAKE UP 1	
<input checked="" type="checkbox"/> ON	
<input type="checkbox"/> OFF	

WAKE UP 1	
WAKE UP 1	07:00

On display appears exist status of wake up timers. To chose timer use scroll keys “COLD”&”CUP”. Press “OK” to enter the set menu.

Choose “ON” to activate the times or “OFF” to deactivate it.

To change hour and minute use scroll keys “COLD”&”CUP”. Press “OK” to confirm.

### 5.3.3. Energy saving mode timer set.

The energy saving mode timer automatically switches the heating system into “sleep mode” after predefined period of time. To set energy saving mode timer enter into “energy saving” sub-menu

**MAIN MENU** → **TIME & DATE** → **ENERGY SAVING**

ENERGY SAVING	
SHUT OFF HEATER	
AFTER:	60 MIN

On display appears exist SET parameter. To change SET use scroll keys “COLD”&”CUP”. Press “OK” to confirm.

### 5.3.4 Automatic Power Down timer set

The power down timer automatically switches the system “OFF” after predefined period of time. To set automatic power down mode timer enter into “power down” sub-menu

**MAIN MENU** → **TIME & DATE** → **POWER DOWN**

POWER DOWN	
AUTOMATIC	
POWER DOWN	OFF

On display appears SET parameter. To change SET use scroll keys “COLD”&”CUP”. Press “OK” to confirm.

### 5.3.5 Child lock mode set

To activate child protection enter into “child protection” sub-menu

**MAIN MENU** → **SETTINGS** → **CHILD LOCK**

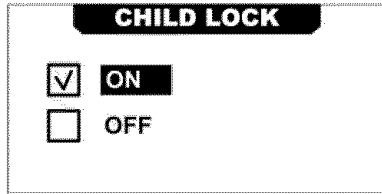

On display appears exist system mode.  
To change use scroll keys  
“COLD”&”CUP”.  
Press “OK” to confirm.

### 5.3.6 Spout light option

To activate spout light option enter into “spout light” sub-menu

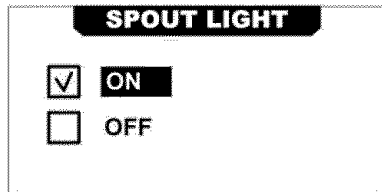

On display appears exist option mode.  
To change use scroll keys  
“COLD”&”CUP”.  
Press “OK” to confirm.

### 5.3.7 Clock view option

There are two main display view option: TanaWater Logo or Clock. To activate clock view enter into “spout light” sub-menu

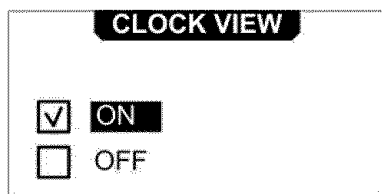

On display appears exist option mode.  
To change use scroll keys  
“COLD”&”CUP”. Press “OK” to  
confirm.

### 5.3.8 Units

To “metric” or “Imperial” measurement system enter into “units” sub-menu

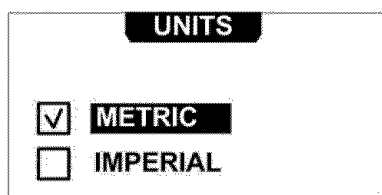

On display appears exist option mode.  
To change use scroll keys  
“COLD”&”CUP”. Press “OK” to  
confirm.

### 5.3.9 Beep on key option

To activate spout beep-on-key option enter into “beep on key” sub-menu

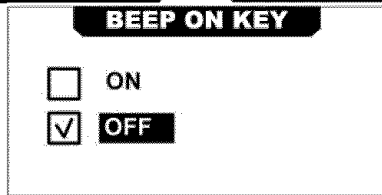

On display appears exist option state.  
To change use scroll keys  
“COLD”&”CUP”.  
Press “OK” to confirm.

### 5.3.10 Language

To chose language enter into “language” sub-menu

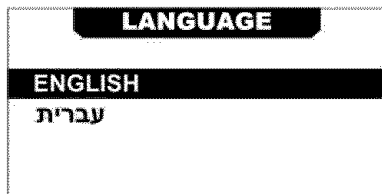

On display appears exist language.  
To change use scroll keys  
“COLD”&”CUP”.  
Press “OK” to confirm.

### 5.3.11 Restore factory settings

To restore factory settings enter into “restore settings” sub-menu

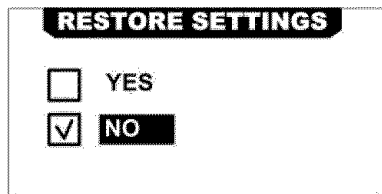

On display appears exist system state.  
To change use scroll keys  
“COLD”&”CUP”.  
Press “OK” to confirm.  
Default factory settings:

- child lock - activated
- automatic energy saving – 60 min
- automatic power down – OFF
- beep on key – OFF
- spout light - ON

### 5.3.12 Cold water temperature set (thermostat set)

To set cold water thermostat enter into “cold water temperature” sub-menu

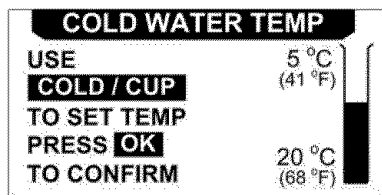

The temperature bar proportionally indicate the cold thermostat set  
To change use scroll keys  
“COLD”&”CUP”. Press “OK” to confirm.

### 5.3.13 Dosage cold water quantity set

To set cold water dispensing dose ("CUP" key) enter into "cold water quantity" sub-menu

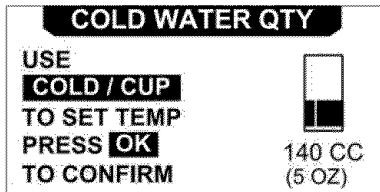

On the display appears current cold-water dose set.

Setting range 60 – 300 cc (2-10 oz)

To change use scroll keys

"COLD" & "CUP".

Press "OK" to confirm.

### 5.3.14 MIX water temperature set

To set MIX (predefined temperature and quantity dispensing) water temperature enter into "mix water temperature" sub-menu

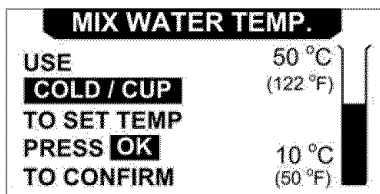

The temperature bar proportionally indicate the desired mix water temperature set

To change use scroll keys

"COLD" & "CUP".

Press "OK" to confirm.

### 5.3.15 MIX water quantity set

To set MIX (predefined temperature and quantity dispensing) water dose quantity enter into "mix water quantity" sub-menu

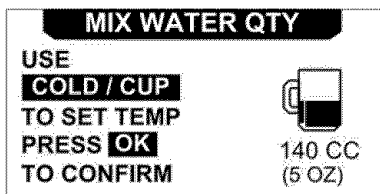

On the display appears current mix-water dose set.

Setting range 60 – 300 cc (2-10 oz)

To change use scroll keys

"COLD" & "CUP".

Press "OK" to confirm.

### 5.3.16 HOT water quantity set

To set HOT water dose quantity enter into "hot water quantity" sub-menu

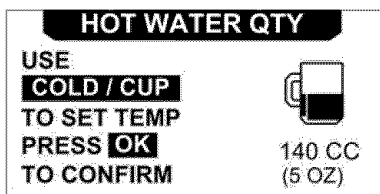

On the display appears current mix-water dose set.

Setting range 60 – 300 cc (2-10 oz)

To change use scroll keys

"COLD" & "CUP".

Press "OK" to confirm.

## 6. Maintenance and replacement.

### 6.1 Drop collector emptying.



System will alarm when drop collector full.

Drop collector emptying:

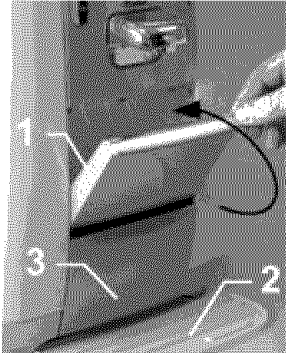

Close folding drip tray (1) and wait few seconds until the water will fall down into the drop collector.  
Remove bottom deco panel (2)

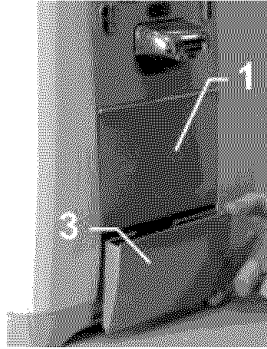

Remove drop collector (3) and empty it.

### 6.2 Replacement

Filter should be replaced every 6 months (about 2000 liter (530 gallon) water)

UV lamp should be replaced every 12 months.



The “Replace filter” notice will appear 6 months after last filter counter reset is elapsed.



The “Replace lamp” message will appear 12 months after last UV lamp counter reset is elapsed.

### 6.3 Counters display

It is possible to display filter and UV lamp current status.

Enter “replacement” sub-menu to display and reset counters.



### 6.4 Filter replacement

Filter replacement procedure:

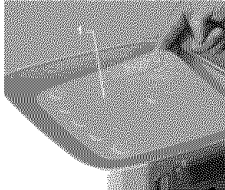

1. Remove top deco cover

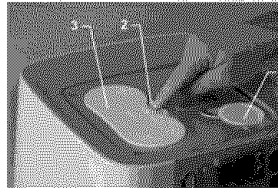

2. Press on filter release button

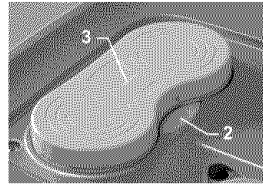

3. Make sure filter out of filter housing

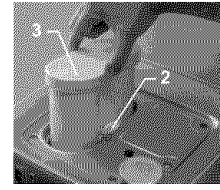

4. Remove filter upwards.

Note: Reset filter counter after installing a new filter

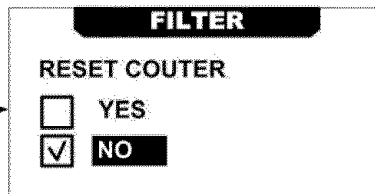
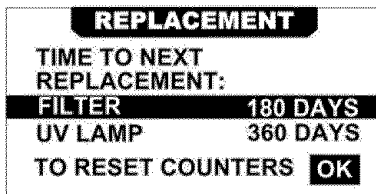

### 6.5 UV lamp replacement

UV lamp replacement procedure:

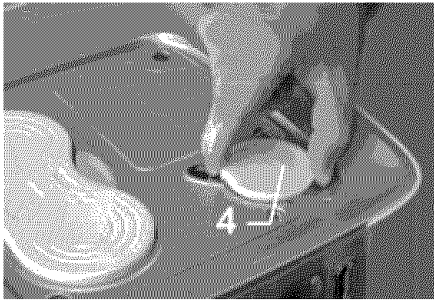

1. Capture the UV lamp cover (4)

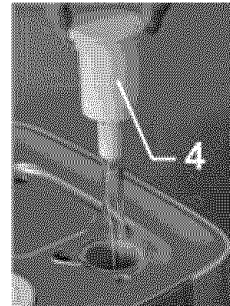

2. Remove the lamp upwards  
3. Insert the new lamp

**Note:** The system will alarm when UV lamp removed out . On the display appears “UV LAMP REMOVED REPLACE UV LAMP”. Water dispensing is not allowed when the lamp is disconnected.

Be sure to reset UV lamp counter after replacing the lamp. The counter will automatically reset when “NEW LAMP INSTALLED” is confirmed.

## 7. Cleaning the appliance

Use only a soft cloth and warm, soapy water when cleaning the appliance, and a dry cloth only when cleaning the operating panel.

The top and bottom trays are suitable for dishwasher cleaning. Please do not use harsh detergents, concentrated liquid cleaners, solvents or any material likely to scratch the appliance's casing (i.e. Scotch-Brite, steel wool, etc.).

**Please note: The appliance is connected to an electrical source. Do not wet the back of the machine.**

## 8. Weekends / Holidays / Vacations

For safety reasons, if you plan not to use the machine for a day or more, please disconnect the appliance from its electrical source and close the water inlet port. After reconnecting, allow water to flow through the appliance for 5-10 minutes.

## 9. Warning \* Safety \* Service

**Warning: Moving the appliance may cause flooding.**

The T-6 model operates using a 230/115V Volt electrical current, and must be connected to a socket with a 10 Ampere fuse. During operation and maintenance, please take all safety measures required for operation of an electrical appliance.

This appliance dispenses water at a very high temperature – do not let children use it without adult supervision. The activation of a “Child Safety” mode is possible – please see the explanation on page 9, part 3.

**Warning:** Warm water is dispensed through two different spouts. To pour warm water into a bottle with a narrow spout, please use a funnel, or first dispense the water into a container with a wide spout.



In the case of any announcements from the Ministry of Health regarding water sanitary failure or fault, drinking water must be boiled and Ministry of Health instructions followed.

After any such sanitary fault or failure is declared resolved, we recommend that the filter be replaced.

The water system is secure as the tanks are not pressurized and open as there are no valves between the hot or cold water tanks and the spout. Therefore, light dripping as a result of water flow is standard and to be expected.

During the filtration process, phosphorus ions are emitted into the water in volume lower than the maximal amount permitted by drinking water standards. We recommend that people with health issues consult a physician before using the system.

Maintenance and service of the dispenser must be performed by certified company service personnel. The manufacturer, Tana Water, relinquishes any responsibility for injury or damage to property as a result of improper use or maintenance of this appliance.

**For further information, explanations regarding operation and care, contact your local distributor.**

## 10. Troubleshooting

### 10.1 Customer

Your water dispenser is extremely reliable, and requires almost no maintenance and service, except for the replacement of the filter and the UV lamp at pre-defined intervals.

Before you schedule a visit by a technician, please consult the following table to ensure that you are experiencing a system fault, and not a problem with electricity or water supply.

Fault	Possible causes	Actions to take
No water flow	<ul style="list-style-type: none"> <li>Dispenser is not plugged in to an electrical socket</li> <li>Faulty electrical socket</li> <li>The main water supply is closed</li> <li>There is a water stoppage</li> </ul>	<ul style="list-style-type: none"> <li>Ensure dispenser is plugged in to an electrical socket</li> <li>Check that socket is operating properly by plugging in a different appliance</li> <li>Open the water tap</li> <li>Check other taps for water flow</li> </ul>
No hot water flow	<ul style="list-style-type: none"> <li>The heating system is not activated</li> <li>Abundant hot water consumption</li> </ul>	<ul style="list-style-type: none"> <li>Ensure the heating system switch at the rear of the dispenser is in position “1” – active</li> <li>Wait 10 minutes and check again</li> </ul>
No cold water	<ul style="list-style-type: none"> <li>Cold water temperature setting is too high</li> <li>Abundant cold water consumption</li> </ul>	<ul style="list-style-type: none"> <li>Check the cold water temperature setting</li> <li>Wait 30 minutes and check again</li> </ul>
Leaks	<ul style="list-style-type: none"> <li>Drip tray full</li> <li>Leaks from the appliance itself</li> </ul>	<ul style="list-style-type: none"> <li>Empty the drip tray</li> <li>Disconnect the dispenser from the power source, close the water inlet port and call a service technician</li> </ul>
Aftertaste	<ul style="list-style-type: none"> <li>New appliance</li> <li>Appliance has not been used for a long time</li> <li>Filter not replaced on schedule</li> </ul>	<ul style="list-style-type: none"> <li>Let water flow through the appliance for 10-15 minutes</li> <li>Replace the filter</li> <li>Replace the filter</li> </ul>

## 10.2 Technician

### 10.2.1 System Diagnostic (STATUS DISPLAY)

For fast and easy system diagnostics use status display. To enter Status display press “back” key during 10 sec constantly.

T-6 2.52					
HT 97	DV 30	CT 6			
HB 95	CN -1	CB 3			
HE 10	FN OFF	CP OFF			
HV OFF	MV OFF	CV OFF			
HS NM	DS OUT	UV IN			
WU 200	FS OUT	UV ON			
ERR 3, 6		BT 100			

On display appears exist system status:

- Temperature sensors readings
- Compressor, heating element, UV lamp and valve state;
- Error indication
- Boiling temp

Table of states:

Sign	Description	Value
HT	Hot Top sensor	Temperature reading range 10 – 110 C -1 disconnect -2 short cut
HB	Hot Bottom Sensor	Temperature reading range 10 – 110 C -1 disconnected -2 short cut
HE	Heating Element status	10 – full power 1-9 – partial capacity 0 - off
HV	Hot Valve status	ON – open OFF - closed
HS	Heating System status	NM – normal mode SL – energy saving EX – extra hot mode PD – power down
WU	Water Usage counter	Water quantity in liters
DV	Device temperature sensor	Temperature reading range 10 – 80 C -1 disconnected -2 short cut
CN	Condenser sensor (option)	
FN	Fan status	ON – operates OFF – not operates
MV	Main (inlet) valve status	ON – open OFF - closed
DS	Drop collector sensor	IN – drop collector installed OUT –drop collector not installed
FS	Filter sensor (option)	
CT	Cold Top temperature sensor	Temperature reading range -10 – 50 C -1 disconnected -2 short cut
CB	Cold Bottom temperature sensor	Temperature reading range -10 – 50 C -1 disconnected -2 short cut
CP	Compressor status	ON – operates OFF – not operates 1 – 180 – delay counter status (second)
CV	Cold water valve	ON – open OFF - closed
UV	UV lamp position	IN – installed OUT – not installed

UV	UV lamp status	ON – operates OFF – not operates
BT	Boiling temperature set	Current Boiling Temperature set, °C/ °F
ERR	Error status	Error see table par. 10.2.1

### 10.2.2 Error indication table

T6 indication	Description	System	Action	Reset	Note
ERR 01	Top/bottom cold sensor is shortcut.	Disable compressor	Check sensor harness connections; Check sensors.	Power up	
ERR 02	Top/bottom cold sensor is disconnected	Disable compressor	Check sensor harness connections; Check sensors.	Power up	
ERR 03	UV system malfunction	Disable cold/mix water dispensing	Check UV lamp Check UV system harness connections. Check UV card	Power up	Beep on cold/mix key
ERR 04	Max. working time of the compressor elapsed	Disable compressor for period of time	Check cooling system (gas leak, fan, compressor)	Canceled after pause Or power up	
ERR 05	Top/bottom hot sensor is short-cut.	Stop heating	Check sensor harness connections; Check sensors.	Power up	
ERR 06	Top/bottom hot sensor is disconnected	Stop heating	Check sensor harness connections; Check sensors.	Power up	
ERR 07	Temperature sensor reads the defined boil temperature	Stop heating	Check hot sensors location, Check hot sensors readings	Power up	
ERR 08	Max. working time of the heater elapsed	Stop heating	Check switch (ON/OFF) position on the back panel. Check switch harness, Check heater	Press on Hot / E.Hot key Power up	
ERR 09	Cold valve is activated for the max. defined time	Stop any water dispensing	Check MCU operation panel	Power up	
ERR 10	Hot valve is activated for the max. time defined	Stop any water dispensing	Check MCU operation panel	Power up	
ERR 11	Inlet valve is activated for the max. time defined	Stop any water dispensing	Check MCU operation panel	Power up	
ERR 20	Big temperature difference between top and bottom top water sensors	Stop heating	Check sensors location. Check sensors readings.	Press on Hot / E.Hot key	
ERR 22	Device sensor is shortcut	Error Indication	Check device sensor	Automatic	
ERR 23	Device sensor is disconnected	Error Indication	Check device sensor	Automatic	

### 10.2.3 Technician service menu (SERVICE DISPLAY)

The service menu is used to set different system parameters. To enter SERVICE display press “Menu” key and press “CUP” key simultaneously for 10 sec.

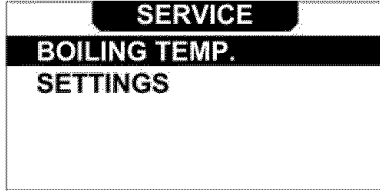

The following options will appear on the display:

1. Boiling temperature set (without entering installation procedure)
2. Settings

*Note: Changing the setting parameters may cause the system malfunction. Please consult the factory.*

## 11. Electric diagram

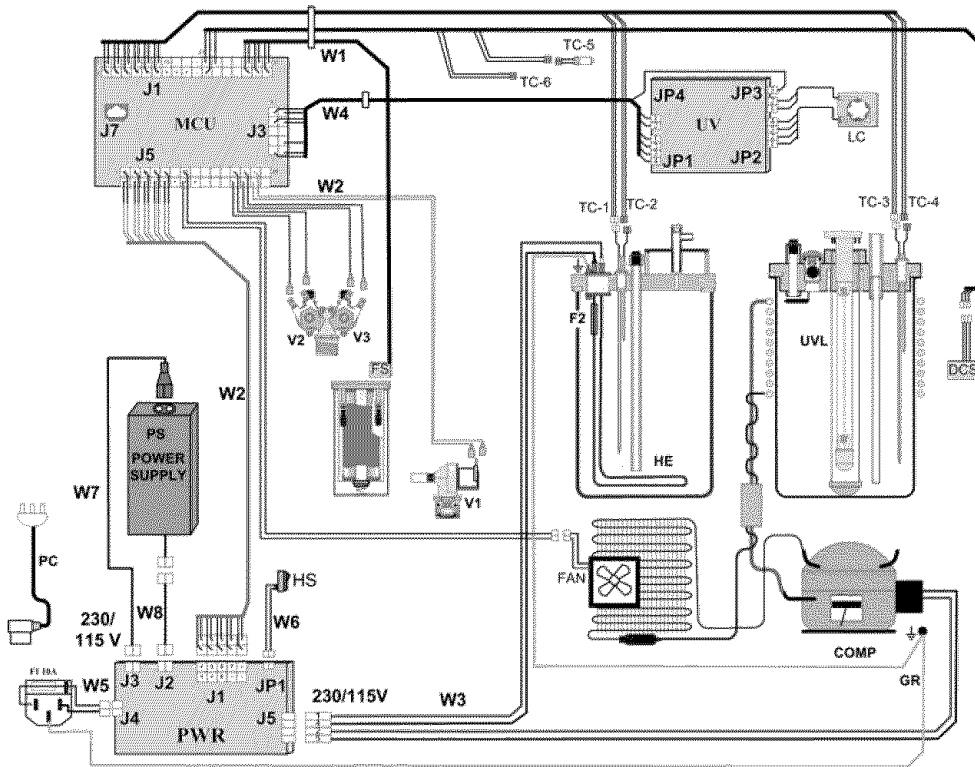

CODE	DESCRIPTION	NOTE
MCU	PCB Main control unit	
PWR	PCB High voltage driver	
UV	PCB UV lamp driver	
PS	Power supply	3A, DC
LC	UV lamp connector	
DCS	Drop collector sensor	
FS	Filter sensor	Option
COMP	Compressor	230V 115V
HE	Heating element	230V, 1800W 115V, 950W
F1	Inlet fuse	10A
F2	Thermal fuse	Built-in
UVL	UV lamp	115V
V1	Main valve	12VDC
V2	Cold water valve	12VDC
V3	Hot water valve	12VDC
FAN	Air Fan	12VDC
W1	Sensor Harness	12v
W2	12 volt harness	
W3	High voltage harness	
W4	UV harness	
W5	Inlet harness	
W6	Heat switch harness	12VDC
W7	Inlet cable to PS	High volt.
W8	Outlet wire from PS	12VDC
HS	Heating system switch	12VDC
TC-1	Bottom HWT sensor	Thermistor
TC-2	Top HWT sensor	Thermistor
TC-3	Bottom CWT sensor	Thermistor
TC-4	Top CWT sensor	Thermistor
TC-5	Device temp. sensor	Thermistor
TC-6	Condenser temp sensor	Optional
PC	Inlet power cable	

Note: For 115 volt Fuse F1 = 12 A

**12 Parts list**  
**12.1 Exploded view**

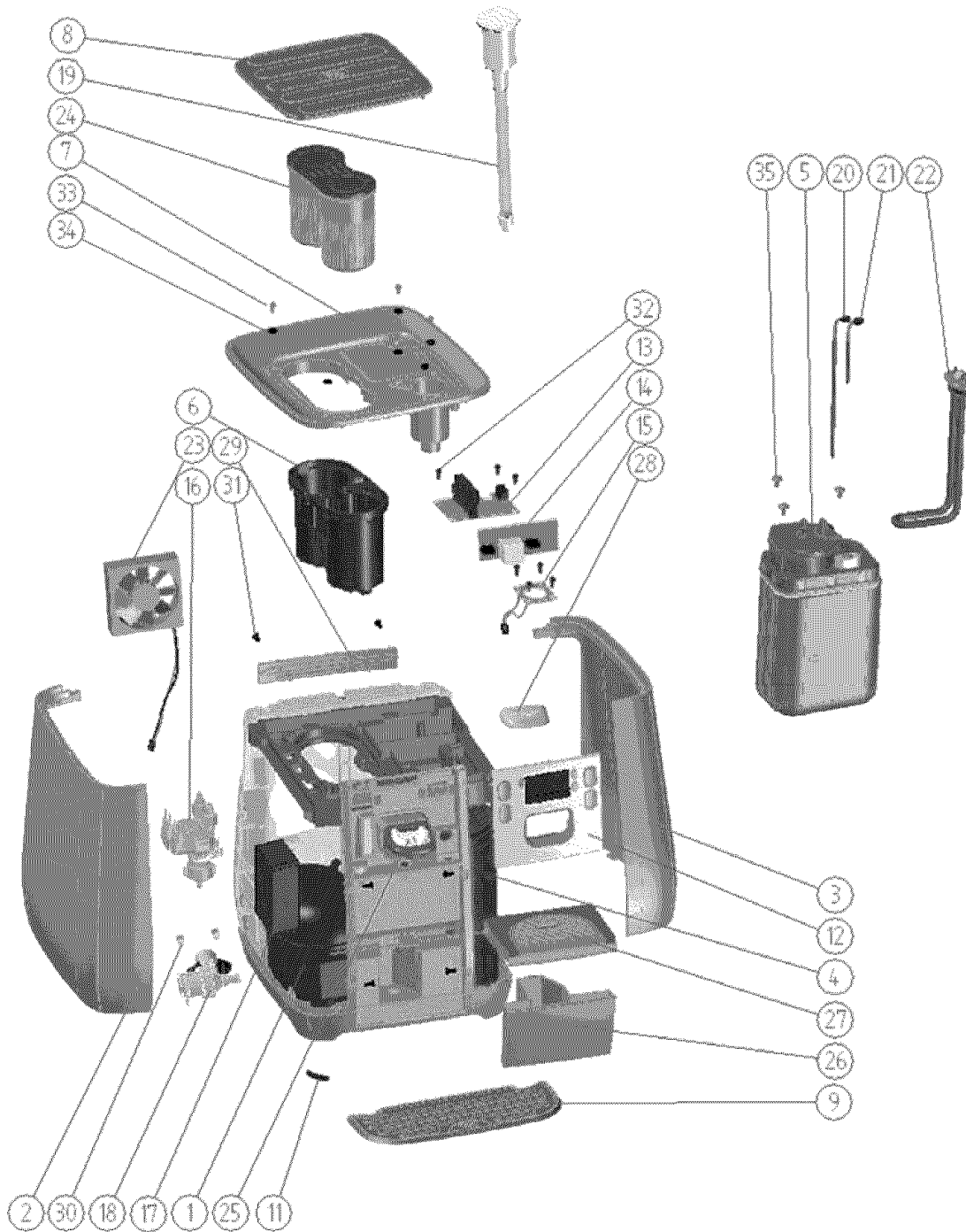

No	Description	Code	Specification	Note
1.	Compressor	106052	1/12 hp 230 volt	
2.	Left wall – silver - white	106308 106019		
3.	Right wall – silver - white	106307 106018		
4.	CWT assembly	106350		
5.	HWT assembly	106331	230 volt 1800 watt	
6.	Filter housing	106313		
7.	Top cover	106021		
8.	Top Deco Panel	106022		
9.	Bottom deco tray	106023		
10.				
11.	Base leg	106024		
12.	MCU panel ASSY.	106142		
13.	PWR-PCB	106120		
14.	UV-PCB	106317		
15.	UV lamp-PCB connector	106123		
16.	Double valve	106076	12 VDC	
17.	Power supply	106111		
18.	Single valve	106077	12 VDC	
19.	UV lamp ASSY.	106204		
20.	Sensor long	106109		
21.	Sensor short	106108		
22.	Heating element	106060	1800 watt 230 volt	
23.	Fan	106040	12 VDC	
24.	Filter	106337	M1 (0.6 micron nominal)	
25.	Spout	106028		
26.	Drop collector	106343		
27.	Folding tray ASSY.	106079		
28.	Spout cover	106025		
29.	Walls connector -silver	106309		
30.	Screw	106043		
31.	Screw	106044		
32.	Screw	4811030610		
33.	Screw	106045		
34.	Washer	106068		
35.	Screw	106046		

**12.2 Parts catalogue**

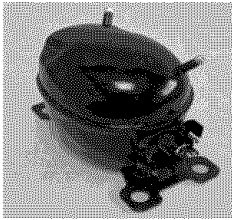

COMPRESSOR  
P/N-106252



RIGHT WALL  
P/N- 106307

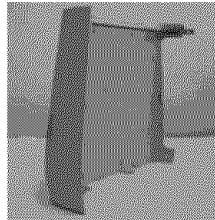

LEFT WALL  
P/N- 106308



CWT ASSY.  
P/N- 106350

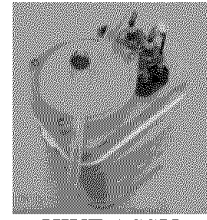

HWT ASSY  
P/N-106331

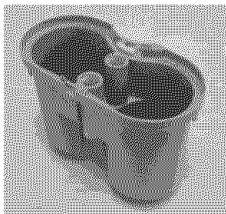

FILTER HOUSING  
P/N -106313

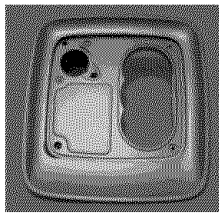

TOP COVER  
P/N- 106021

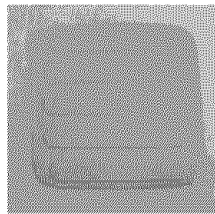

TOP DECO  
PANEL  
P/N-106338

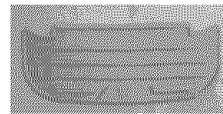

BOTTOM DECO  
TRAY  
P/N-106339

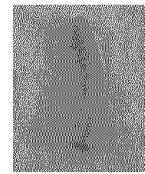

BASE LEG  
P/N- 106024

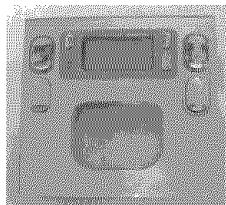

MCU PANEL  
P/N-106142

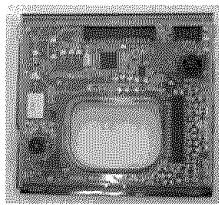

MCU-PANEL  
P/N-106142

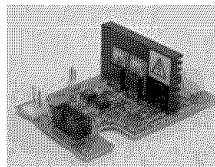

PWR-PCB  
P/N- 106120

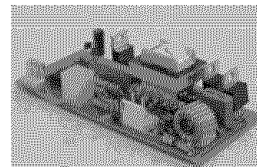

UV-PCB  
P/N-106317

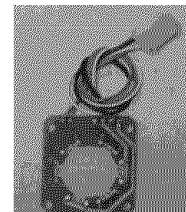

UV LAMP-PCB  
P/N- 106123

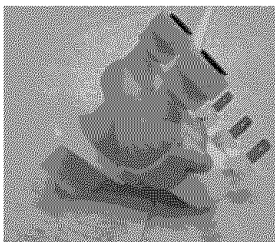

DOUBLE VALVE  
P/N-106076

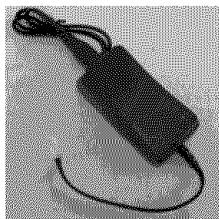

POWER SUPPLY  
P/N-106111

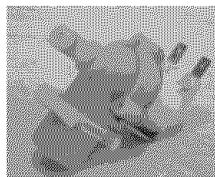

SINGLE VALVE  
P/N-106077

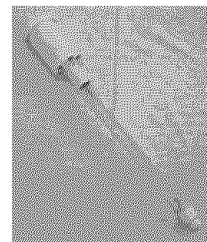

UV LAMP  
P/N-106204

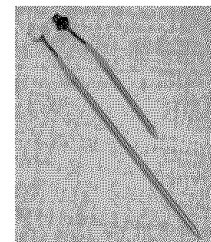

SENSOR  
LONG-106109  
SHORT-106108

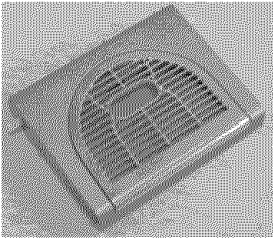

FOLDING TRAY  
P/N-106079

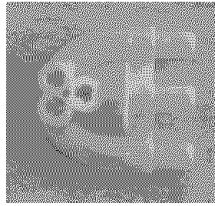

SPOUT  
P/N-106028

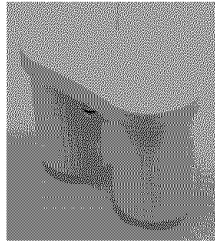

CARBONE  
FILTER  
P/N-106337

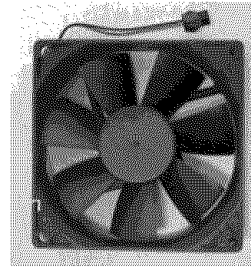

FAN  
P/N-106040



HEATING  
ELMENT  
P/N-106060

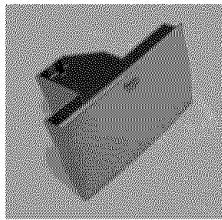

DROP  
COLLECTOR  
P/N-106343

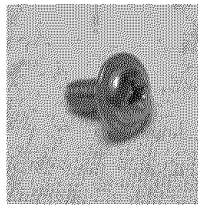

SCREW  
P/N-106045

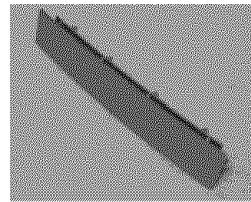

WALLS  
CONNECTOR  
P/N-106309

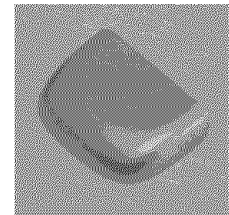

SPOUT COVER  
P/N-106025

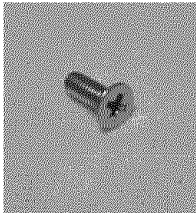

SCREW  
P/N-106044

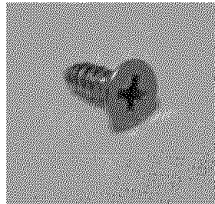

SCREW  
P/N-106043

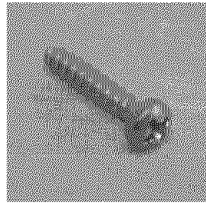

SCREW  
106046

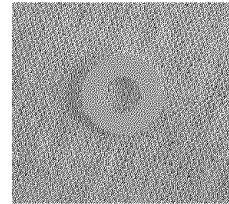

WASHER  
106068

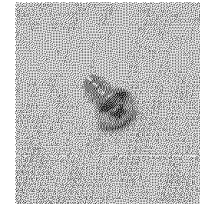

SCREW  
P/N-4811030610