

# Installation Manual

**LKM-A111-BC / LKM-A121-BC**

**LKM-A111-BD / LKM-A121-BD**

S-AIT Tape Drive Unit

S-AIT is an abbreviation of Super Advanced Intelligent Tape

LMQT00623

Rev. A

# Table of Contents

---

## **LKM-A111-BC / LKM-A111-BD**

<b>IMPORTANT SAFETY NOTICE</b> .....	2
<b>WICHTIGE SICHERHEITSHINWEISE</b> – German – .....	4
<b>Introduction</b> .....	6
About LKM-A111-B Tape Drive .....	6
Product Features .....	6
System Requirements .....	7
Kit Contents ( attached ) .....	7
Precautions .....	8
<b>Parts and Functions</b> .....	9
Front View .....	9
Rear View .....	10
<b>Installation</b> .....	11
Option Switches (DIP Switch) .....	11
Connecting .....	11

---

## **LKM-A121-BC / LKM-A121-BD**

<b>IMPORTANT SAFETY NOTICE</b> .....	14
<b>WICHTIGE SICHERHEITSHINWEISE</b> – German – .....	16
<b>Introduction</b> .....	18
About LKM-A121-B Tape Drive .....	18
Product Features .....	19
System Requirements .....	20
Kit Contents ( attached ) .....	20
Precautions .....	21
<b>Parts and Functions</b> .....	22
Front View .....	22
Rear View .....	23
<b>Installation</b> .....	24
FC Connection/Setting the LOOP ID .....	24
Arbitrated Loop Physical Addresses (AL_PA) and Loop IDs .....	25
Option Switches (DIP Switch) .....	26
Connecting .....	26

---

## Operation

( for Model LKM-A111-BC / LKM-A111-BD / LKM-A121-BC / LKM-A121-BD ) .....	27
LED Indication for Drive Status .....	27
Drive Operation .....	28

## Interface Implementation

( for Model LKM-A111-BC / LKM-A111-BD / LKM-A121-BC / LKM-A121-BD ) .....	29
Supported SCSI Messages .....	29
Supported SCSI Commands .....	29

## Maintenance

( for Model LKM-A111-BC / LKM-A111-BD / LKM-A121-BC / LKM-A121-BD ) .....	30
Filter Exchanging .....	31

## Specification

( for Model LKM-A111-BC / LKM-A111-BD / LKM-A121-BC / LKM-A121-BD ) .....	32
Cartridge Tape Performance .....	32
General Performance .....	32
Environmental Conditions .....	32

## Appendix

( for Model LKM-A111-BC / LKM-A111-BD / LKM-A121-BC / LKM-A121-BD ) .....	33
Mounting the Drive Unit to Rack .....	33

## Anhang – German –

( für den Typ LKM-A111-BC / LKM-A111-BD / LKM-A121-BC / LKM-A121-BD ) .....	34
Montage .....	34

# **Installation Manual**

**LKM-A111-BC / LKM-A111-BD**

# IMPORTANT SAFETY NOTICE

## NOTICE

- (1) You may not reproduce or transcribe any part of this publication without permission.
- (2) We reserve the right to revise this document at any time without notice.
- (3) If you have any questions about this document, contact your sales representative.

## SAFETY NOTICE

- (1) To prevent fire or electric shock, do not expose this appliance to rain or moisture.
- (2) To avoid electric shock, do not attempt to disassemble the cabinet.
- (3) For pluggable equipment, the socket-outlet shall be installed near the equipment and shall be easily accessible.

### For USA (Model LKM-A111-BC only)

#### FEDERAL COMMUNICATIONS COMMISSION (FCC) RADIO FREQUENCY INTERFERENCE STATEMENT

##### Class B Computing Device

**NOTE :** This equipment has been tested and found to comply with the limits for a Class **B** digital device, pursuant to part 15 of the FCC Rules. These limits are designed to provide reasonable protection against harmful interference in a residential installation. This equipment generates, uses and can radiate radio frequency energy and , if not installed and used in accordance with the instructions, may cause harmful interference to radio communications. However, there is no guarantee that interference will not occur in a particular installation. If this equipment does cause harmful interference to radio or television reception, which can be determined by turning the equipment off and on, the user is encouraged to try to correct the interference by one or more of the following measures :

- Reorient or relocate the receiving antenna.
- Increase the separation between the equipment and receiver.
- Connect the equipment into an outlet on a circuit different from that to which the receiver is connected.
- Consult the dealer or an experienced radio/TV technician for help.

**FCC WARNING :** Changes or modifications not expressly approved by the party responsible for compliance could void the user's authority to operate the equipment.

##### CAUTION :

Use shielded connecting cables in order to meet FCC emission limits and also to prevent interference to nearby radio and television reception.

### For Model LKM-A111-BC

This product can be used with the attached power cord only.

### For Model LKM-A111-BD

##### IMPORTANT :

If the power cord is not attached when purchasing this equipment, consult with your dealer, etc.

" Use only Safety Licensed Power Cord on the relevant regulations. "

A certified power cord is to be used with this equipment. For a rated current up to 6 A, a type not lighter than H05VV-F3G 0.75 mm<sup>2</sup> or H05VVH2-F 3G 0.75 mm<sup>2</sup> shall be used.

---

## IMPORTANT SAFETY INSTRUCTIONS

1. Read all of these instructions.
2. Save these instructions for later use.
3. Follow all warnings and instructions marked on the product.
4. Unplug this product from the wall outlet before cleaning. Do not use liquid cleaners or aerosol cleaners. Use a damp cloth for cleaning.
5. Do not use this product near water.
6. Do not place this product on an unstable rack, cart, stand, or table. The product may fall, causing serious damage to the product.
7. This product should be operated from the type of power source indicated on the marking label. If you are not sure of the type of power available, consult your dealer or local power company.
8. This product is equipped with a 3-wire grounding type plug, a plug having a third (grounding) pin. This plug will only fit into a grounding-type power outlet. This is a safety feature. If you are unable to insert the plug into the outlet, contact your electrician to replace your obsolete outlet. Do not defeat the purpose of the grounding-type plug.
9. Do not allow anything to rest on the power cord. Do not locate this product where persons will walk on the cord.
10. If an extension cord is used with this product, make sure that the total of the ampere ratings on the products plugged into the extension cord do not exceed the extension cord ampere rating. Also, make sure that the total of all products plugged into the wall outlet does not exceed 15 amperes.
11. Never push objects of any kind into this product through cabinet slots as they may touch dangerous voltage points or short out parts that could result in a risk of fire or electric shock. Never spill liquid of any kind on the product.
12. Do not attempt to service this product yourself, as opening or removing covers may expose you to dangerous voltage points or other risks. Refer all servicing to service personnel.
13. Unplug this product from the wall outlet and refer servicing to qualified service personnel under the following conditions:
  - A. When the power cord or plug is damaged or frayed.
  - B. If liquid has been spilled into the product.
  - C. If the product has been exposed to rain or water.
  - D. If the product does not operate normally when the operating instructions are followed. Adjust only those controls that are covered by the operating instructions since improper adjustment of other controls may result in damage and will often require extensive work by a qualified technician to restore the product to normal operation.
  - E. If the product has been dropped or the cabinet has been damaged.
  - F. If the product exhibits a distinct change in performance, indicating a need for service.
14. Slots and openings in the cabinet and back or bottom are provided for ventilation and to ensure reliable operation of the product and to protect it from overheating. These openings must not be blocked or covered.

# WICHTIGE SICHERHEITSHINWEISE

## HINWEISE

- (1) Ohne Genehmigung dürfen keine Auszüge dieser Veröffentlichung reproduziert oder übertragen werden.
- (2) Wir behalten uns das Recht vor, dieses Dokument jederzeit ohne Vorankündigung zu überarbeiten.
- (3) Wenn Sie Fragen zu diesem Dokument haben, wenden Sie sich an Ihren Verkaufsrepräsentanten.

## SICHERHEITSHINWEISE

- (1) Setzen Sie dieses Gerät zur Vermeidung eines Brandes oder elektrischen Schlages weder Regen noch Feuchtigkeit aus.
- (2) Versuchen Sie zur Vermeidung eines elektrischen Schlages nicht, das Gehäuse auseinander zu bauen.
- (3) Bei steckbaren Geräten sollte die Steckdose in der Nähe der Geräte installiert werden und leicht zugänglich sein.

## VORSICHT

Diese Ausrüstung erfüllt die Europäischen EMC-Bestimmungen für die Verwendung in folgender / folgenden Umgebung(en):

- Wohngegenden
- Gewerbegebiete
- Leichtindustriengebiete

(Diese Ausrüstung erfüllt die Bestimmungen der Norm EN55022, Klasse B.)

### Für den Typ LKM-A111-BC

Dieses Gerät kann nur mit dem beigefügten Netzkabel betrieben werden.

### Für den Typ LKM-A111-BD

#### WICHTIG :

Wenden Sie sich an Ihren Händler usw., wenn das Netzkabel beim Kauf des Gerätes nicht montiert ist.

"Verwenden Sie ausschließlich sicherheitsgeprüfte, den geltenden gesetzlichen Bestimmungen entsprechende Netzkabel."

Mit diesem Gerät ist ein zertifiziertes Netzkabel zu verwenden. Für eine zulässige Stromstärke von bis zu 6 A sollte ein Netzkabeltyp verwendet werden, der nicht leichter ist als H05VV-F3G 0,75 mm<sup>2</sup> oder H05VVH2-F 3G 0,75 mm<sup>2</sup>.



## WICHTIGE SICHERHEITSANWEISUNGEN

1. Lesen Sie sich alle hier aufgeführten Anweisungen durch.
2. Bewahren Sie diese Anweisungen für eine spätere Verwendung auf.
3. Befolgen Sie alle auf dem Produkt gekennzeichneten Warnungen und Anweisungen.
4. Trennen Sie dieses Produkt vor der Reinigung von der Wandsteckdose ab. Verwenden Sie keine Flüssigreiniger oder Aerosolreiniger. Reinigen Sie das Gerät mit einem feuchten Tuch.
5. Verwenden Sie dieses Produkt nicht in der Nähe von Wasser.
6. Stellen Sie dieses Produkt nicht auf einem instabilen Rack, Wagen, Ständer oder Tisch auf. Das Produkt könnte unter Umständen herunter fallen und ernsthafte Beschädigungen davontragen.
7. Dieses Produkt sollte von der auf dem Leistungsaufkleber aufgeführten Spannungsquelle betrieben werden. Wenn Sie nicht sicher sind, welche Spannung verfügbar ist, wenden Sie sich an Ihren Händler oder an Ihr örtliches Energieversorgungsunternehmen.
8. Dieses Gerät ist mit einem 3-adrigen Erdungsstecker ausgestattet - einem Stecker mit einem dritten (Erdungs-) Stift. Dieser Stecker passt nur in eine Erdungssteckdose. Hierbei handelt es sich um eine Sicherheitseinrichtung. Wenn sich der Stecker nicht in die Steckdose einstecken lässt, beauftragen Sie bitte einen Elektriker mit dem Austausch Ihrer veralteten Steckdose. Machen Sie den Zweck des Erdungssteckers nicht zunichte.
9. Lassen Sie keinerlei Gegenstände auf dem Netzkabel stehen. Stellen Sie dieses Produkt nicht an einem Ort auf, an dem Personen über das Kabel laufen würden.
10. Stellen Sie bei der Verwendung eines Verlängerungskabels sicher, dass die Gesamtampereleistung der an das Verlängerungskabel angeschlossenen Geräte nicht die Amperereistung des Verlängerungskabels überschreitet. Stellen Sie darüber hinaus sicher, dass alle an die Wandsteckdose angeschlossenen Geräte 15 Ampere nicht überschreiten.
11. Schieben Sie keinerlei Gegenstände über die Gehäuseschlitze in dieses Produkt, da diese gefährliche Spannungspunkte berühren oder Teile kurzschließen könnten. Beides könnte sowohl einen Brand als auch einen elektrischen Schlag zur Folge haben.
12. Versuchen Sie nicht, dieses Produkt selber zu warten, da Sie sich durch das Öffnen und Entfernen von Abdeckungen gefährlichen Spannungspunkten oder anderen Gefahren aussetzen würden. Überlassen Sie sämtliche Wartungsarbeiten dem Kundendienstpersonal.
13. Unter den nachfolgenden Umständen sollten Sie dieses Produkt von der Wandsteckdose abtrennen und qualifiziertem Kundendienstpersonal zur Wartung übergeben:
  - A. Wenn das Netzkabel oder der Stecker beschädigt oder abgenutzt sind.
  - B. Wenn Flüssigkeit in das Produkt gelangt ist.
  - C. Wenn das Produkt Regen oder Feuchtigkeit ausgesetzt worden ist.
  - D. Wenn das Gerät trotz Befolgen der Bedienungsanleitung nicht normal funktioniert. Stellen Sie nur die in der Bedienungsanleitung beschriebenen Regler ein, da eine falsche Einstellung anderer Regler Beschädigungen verursachen kann, und die Wiederherstellung des Normalbetriebes des Produktes durch einen qualifizierten Techniker einen hohen Arbeitsaufwand erforderlich machen würde.
  - E. Wenn das Gerät heruntergefallen ist oder das Gehäuse beschädigt wurde.
  - F. Wenn sich die Leistungsfähigkeit des Gerätes deutlich verändert, was ein Anzeichen dafür ist, dass eine Wartung erforderlich wird.
14. Die sich im Gehäuse, auf der Rückseite und der Unterseite des Gerätes befindlichen Schlitze und Öffnungen dienen der Ventilation und stellen einen zuverlässigen Betrieb des Produktes sicher. Darüber hinaus schützen sie das Gerät vor Überhitzung. Diese Öffnungen dürfen weder blockiert noch abgedeckt werden.

# Introduction

---

## About LKM-A111-B Tape Drive

The LKM-A111-B drive is a high capacity data storage device using Super Advanced Intelligent tape (S-AIT) technology. The LKM-A111-B drive achieves high data reliability through Read-After-Write, an additional level of Error Correction Code, and other features.

The LKM-A111-B drive stores data on tape using a standard format called S-AIT (Super Advanced Intelligent Tape) and ALDC (Adaptive Lossless Data Compression) formats.

## Product Features

	LKM-A111-B
Data Capacity	500 GByte uncompressed (with SAIT-1 600 m tape) 1300 GByte compressed * (with SAIT-1 600 m tape)
Transfer Rate (sustained)	30 MByte/s uncompressed 78 MByte/s compressed *

\* This is assuming 2.6 : 1 compression ratio.

### Product Features

- Supported Format : SAIT-1
- Not compatible with the LTO, DLT and SDLT format tapes
- Burst Transfer Rate –12 MBytes/s Asynchronous  
–160 MByte/s Synchronous
- 72 MByte Buffer Memory
- 5” form factor
- Embedded SCSI Interface  
(Ultra160 Wide LVD/SE SCSI)
- Supports Variable or Fixed Record Length
- Supports SCSI Disconnection/Arbitration
- Read After Write (RAW) On and Off selectable
- Fragment Rewrite Function
- Three levels of Error Correction Code (ECC)
- High Speed search
- Random Read, Append Write

---

## System Requirements

- SCSI Interface Card (Recommended)  
' SCSI Card 29160 ' series (by Adaptec)

Note: This product is NOT supported with other SCSI Interface or PCMCIA card than the above Card.

- SCSI Interface Cable (Recommended)  
ACK-LVD-1M(3M)-U320 (by Adaptec)
- Cartridge-tape (Recommended)  
LKM-SA1-500 ( Panasonic )
- Cleaning Tape (Recommended)  
LKM-SA1-CL ( Panasonic )
- Backup Software (Recommended)  
' Brightstor ARCserve Backup v9 ' or ' Brightstor Enterprise Backup '  
(by Computer Associates)  
' NetVault ' (by BakBone Software)

Note : The actually System Requirements for backup depend on your using Backup software.  
For details, refer to the manual of each Backup software.

## Kit Contents ( attached )

- S-AIT Tape Drive Unit
- Power Cord ( Model LKM-A111-BC only )
- Terminator
- Installation Manual (this book)
- Filter Kit ( for Exchange )
- Cartridge-tape (1 pcs.)
- Cleaning Tape (1 pcs.)
- Warranty Card (with Registration Card)

---

## Precautions

### Installation

Avoid placing the drive in a location subject to:

- high humidity
- high temperature
- mechanical shock and vibration
- direct sunlight

### Operation

- Do not move the drive while it is operating. It may cause malfunction.
- Avoid exposing the drive to sudden changes from a low to high in temperature. This may cause water condensation to collect inside the drive. If the ambient temperature changes suddenly in transit, wait for more than four hours before turning on the drive. If you attempt to operate the drive immediately after a sudden increase in temperature, a malfunction may occur.
- Turning off the power to the drive while it is writing to tape may cause the tape to become unreadable. All previously negotiated parameters will be lost, whenever power to the drive is cycled.
- Upon execution of the hardware reset hole, the driver will be reset and there is a risk of loss and unreadable data. Thus, please do not use the hole other than repair purposes.

### Transportation

- Keep the original packing materials to facilitate transportation of the drive.
- Always remove the tape before moving the drive. After removing the drive from the computer, repack the drive into its original packing.

### Notice of SCSI Termination

- The LKM-A111-B conforms to the Microsoft PC97 standard which requires the external (enclosed) drive to be terminated with an external terminator. Microsoft PC97 SCSI requirements  
SCSI peripherals must not terminate the bus. Both internal and external cable ends are instead terminated by plug-in connectors.

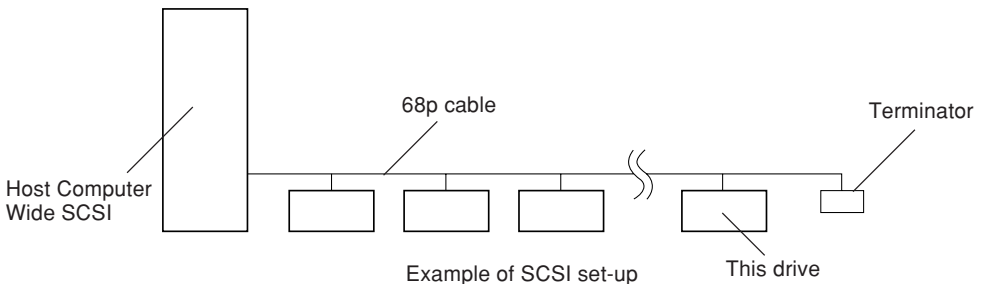

# Parts and Functions

## Front View

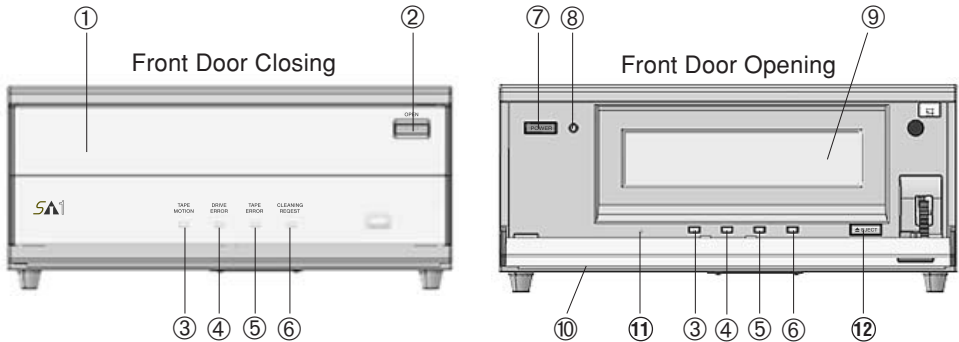

① **Front-Door**

② **Front-Door Button**

Push the button to open the Front-Door

③ **Tape Motion LED** \*1

Indicates the cartridge-tape operating status

④ **Drive Error LED** \*1

Indicates the drive error status

⑤ **Tape Error LED** \*1

Indicates the cartridge-tape error status

⑥ **Cleaning Request LED**

Indicates the cleaning request status

⑦ **Power ON/OFF Switch**

⑧ **Power LED**

Lights up "Green" when the Tape Drive Unit is ON

⑨ **Cartridge-tape Inserting Door**

⑩ **Air Flow Hole ( for absorption )**

Not be blocked or covered to protect this Library from overheating

⑪ **Hard Reset Hole**

Hole for maintenance ( Not use generally )

⑫ **Eject Button**

Takes out the cartridge-tape

\*1) For details of each LED indication status, refer to Page 27.

## Rear View

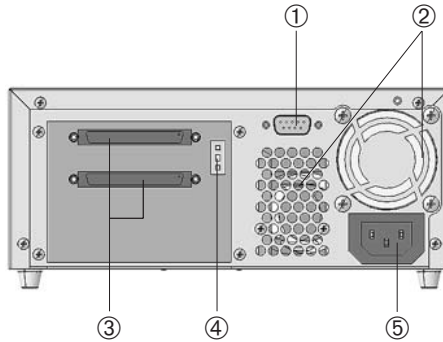

① **Connector for maintenance**

Not use generally

② **Fan / Air Flow Hole ( for release )**

Not be blocked or covered to protect this Library from overheating

③ **SCSI Interface Connector**

Connect the SCSI interface cable ( 68-pin half pitch type )

④ **SCSI ID Switch**

Set up SCSI ID number (other number(0~15) than ones that have already used on your SCSI bus)

Default ID number = " 0 "

⑤ **Power Connector**

Connect the power cord

# Installation

## Option Switches ( DIP Switch )

The dip switches locate on the bottom of this drive.  
( Not operate these switches generally. )

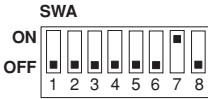

SWA Setting

SW1	Custom-1	OFF
SW2	Custom-2	OFF
SW3	Custom-3	OFF
SW4	Custom-4	OFF
SW5	Reserved	OFF
SW6	Reserved	OFF
SW7	DC Control-1	ON
SW8	DC Control-2	OFF



SWB Setting

SW1	Reserved	OFF
SW2	Reserved	OFF
SW3	Reserved	OFF
SW4	Reserved	OFF
SW5	Reserved	OFF
SW6	Reserved	OFF
SW7	Reserved	OFF
SW8	Reserved	OFF

## Connecting

After make sure that the system (Host PC) power switch is OFF, please connect the S-AIT drive unit as follows.

- 1) Connect the SCSI interface cable to the drive unit.
- 2) Connect the other end of the SCSI interface cable to the system (host PC) SCSI connector.
- 3) Connect the power cord to the drive unit and the outlet with earth, and turn the drive unit power ON.
- 4) Turn the system (host PC) power ON.

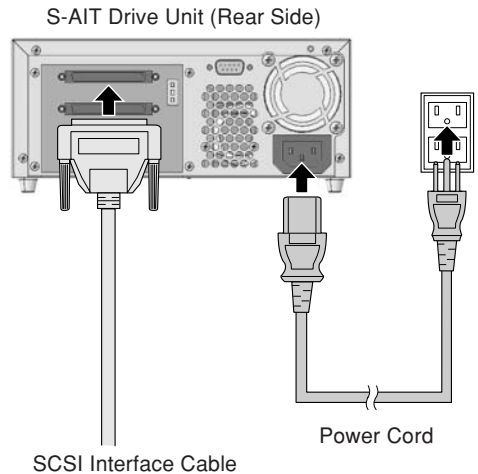

Note :  
For details of SCSI termination, refer to "Notice of SCSI Termination" in Page 8.

# Memo

---



# **Installation Manual**

**LKM-A121-BC / LKM-A121-BD**

# IMPORTANT SAFETY NOTICE

## NOTICE

- (1) You may not reproduce or transcribe any part of this publication without permission.
- (2) We reserve the right to revise this document at any time without notice.
- (3) If you have any questions about this document, contact your sales representative.

## SAFETY NOTICE

- (1) To prevent fire or electric shock, do not expose this appliance to rain or moisture.
- (2) To avoid electric shock, do not attempt to disassemble the cabinet.
- (3) For pluggable equipment, the socket-outlet shall be installed near the equipment and shall be easily accessible.

— **For USA** (Model LKM-A121-BC only) —

### FEDERAL COMMUNICATIONS COMMISSION (FCC) RADIO FREQUENCY INTERFERENCE STATEMENT

#### Class B Computing Device

**NOTE** : This equipment has been tested and found to comply with the limits for a Class **B** digital device, pursuant to part 15 of the FCC Rules. These limits are designed to provide reasonable protection against harmful interference in a residential installation. This equipment generates, uses and can radiate radio frequency energy and , if not installed and used in accordance with the instructions, may cause harmful interference to radio communications. However, there is no guarantee that interference will not occur in a particular installation. If this equipment does cause harmful interference to radio or television reception, which can be determined by turning the equipment off and on, the user is encouraged to try to correct the interference by one or more of the following measures :

- - Reorient or relocate the receiving antenna.
- - Increase the separation between the equipment and receiver.
- - Connect the equipment into an outlet on a circuit different from that to which the receiver is connected.
- - Consult the dealer or an experienced radio/TV technician for help.

**FCC WARNING** : Changes or modifications not expressly approved by the party responsible for compliance could void the user's authority to operate the equipment.

#### CAUTION :

Use shielded connecting cables in order to meet FCC emission limits and also to prevent interference to nearby radio and television reception.

— **For Model LKM-A121-BC** —

This product can be used with the attached power cord only.

— **For Model LKM-A121-BD** —

#### IMPORTANT :

If the power cord is not attached when purchasing this equipment, consult with your dealer, etc.

" Use only Safety Licensed Power Cord on the relevant regulations. "

A certified power cord is to be used with this equipment. For a rated current up to 6 A, a type not lighter than H05VV-F3G 0.75 mm<sup>2</sup> or H05VVH2-F 3G 0.75 mm<sup>2</sup> shall be used.

## LASER SAFETY INFORMATION

This drive unit is classified as a Class 1 Laser Product mounted the drive that is certified to conform to the requirements of the International Electrotechnical Commission (IEC) 60825-1 and CENELEC EN60825-1 for Class 1 laser products.

### CAUTION :

- (1) The use of controls or adjustments or performance of procedures other than those specified herein may result in hazardous radiation exposure.
- (2) Do not look at the end of optical connector with naked eyes or through optical equipment while the power is supplied to this product. Otherwise, your eyes may be injured.

## IMPORTANT SAFETY INSTRUCTIONS

1. Read all of these instructions.
2. Save these instructions for later use.
3. Follow all warnings and instructions marked on the product.
4. Unplug this product from the wall outlet before cleaning. Do not use liquid cleaners or aerosol cleaners. Use a damp cloth for cleaning.
5. Do not use this product near water.
6. Do not place this product on an unstable rack, cart, stand, or table. The product may fall, causing serious damage to the product.
7. This product should be operated from the type of power source indicated on the marking label. If you are not sure of the type of power available, consult your dealer or local power company.
8. This product is equipped with a 3-wire grounding type plug, a plug having a third (grounding) pin. This plug will only fit into a grounding-type power outlet. This is a safety feature. If you are unable to insert the plug into the outlet, contact your electrician to replace your obsolete outlet. Do not defeat the purpose of the grounding-type plug.
9. Do not allow anything to rest on the power cord. Do not locate this product where persons will walk on the cord.
10. If an extension cord is used with this product, make sure that the total of the ampere ratings on the products plugged into the extension cord do not exceed the extension cord ampere rating. Also, make sure that the total of all products plugged into the wall outlet does not exceed 15 amperes.
11. Never push objects of any kind into this product through cabinet slots as they may touch dangerous voltage points or short out parts that could result in a risk of fire or electric shock. Never spill liquid of any kind on the product.
12. Do not attempt to service this product yourself, as opening or removing covers may expose you to dangerous voltage points or other risks. Refer all servicing to service personnel.
13. Unplug this product from the wall outlet and refer servicing to qualified service personnel under the following conditions:
  - A. When the power cord or plug is damaged or frayed.
  - B. If liquid has been spilled into the product.
  - C. If the product has been exposed to rain or water.
  - D. If the product does not operate normally when the operating instructions are followed. Adjust only those controls that are covered by the operating instructions since improper adjustment of other controls may result in damage and will often require extensive work by a qualified technician to restore the product to normal operation.
  - E. If the product has been dropped or the cabinet has been damaged.
  - F. If the product exhibits a distinct change in performance, indicating a need for service.
14. Slots and openings in the cabinet and back or bottom are provided for ventilation and to ensure reliable operation of the product and to protect it from overheating. These openings must not be blocked or covered.

## WICHTIGE SICHERHEITSHINWEISE

### HINWEISE

- (1) Ohne Genehmigung dürfen keine Auszüge dieser Veröffentlichung reproduziert oder übertragen werden.
- (2) Wir behalten uns das Recht vor, dieses Dokument jederzeit ohne Vorankündigung zu überarbeiten.
- (3) Wenn Sie Fragen zu diesem Dokument haben, wenden Sie sich an Ihren Verkaufsrepräsentanten.

### SICHERHEITSHINWEISE

- (1) Setzen Sie dieses Gerät zur Vermeidung eines Brandes oder elektrischen Schlages weder Regen noch Feuchtigkeit aus.
- (2) Versuchen Sie zur Vermeidung eines elektrischen Schlages nicht, das Gehäuse auseinander zu bauen.
- (3) Bei steckbaren Geräten sollte die Steckdose in der Nähe der Geräte installiert werden und leicht zugänglich sein.

### VORSICHT

Diese Ausrüstung erfüllt die Europäischen EMC-Bestimmungen für die Verwendung in folgender / folgenden Umgebung(en):

- Wohngebieten
- Gewerbegebiete
- Leichtindustriegebiete

(Diese Ausrüstung erfüllt die Bestimmungen der Norm EN55022, Klasse B.)

### Für den Typ LKM-A121-BC

Dieses Gerät kann nur mit dem beigefügten Netzkabel betrieben werden.

### Für den Typ LKM-A121-BD

#### WICHTIG :

Wenden Sie sich an Ihren Händler usw., wenn das Netzkabel beim Kauf des Gerätes nicht montiert ist.

"Verwenden Sie ausschließlich sicherheitsgeprüfte, den geltenden gesetzlichen Bestimmungen entsprechende Netzkabel."

Mit diesem Gerät ist ein zertifiziertes Netzkabel zu verwenden. Für eine zulässige Stromstärke von bis zu 6 A sollte ein Netzkabeltyp verwendet werden, der nicht leichter ist als H05VV-F3G 0,75 mm<sup>2</sup> oder H05VVH2-F 3G 0,75 mm<sup>2</sup>.

### LASER-SICHERHEITSINFORMATION

Dieses Laufwerk ist klassifiziert als Laserprodukt der Klasse 1 und erfüllt die Anforderungen der International Electrotechnical Commission (IEC) 60825-1 und CENELEC EN60825-1 an Laserprodukte der Klasse 1.

#### VORSICHT:

- (1) Die Anwendung anderer als der hier spezifizierten Bedienungen, Einstellungen oder Leistungen kann zur Abstrahlung gefährlicher Laserstrahlen führen.
- (2) Bei eingeschalteter Stromversorgung dieses Produkts darf nicht mit bloßen Augen oder mit optischen Geräten in das Ende des Lichtleiterkabel geschaut werden, weil sonst Augenschäden verursacht werden können.

## WICHTIGE SICHERHEITSANWEISUNGEN

1. Lesen Sie sich alle hier aufgeführten Anweisungen durch.
2. Bewahren Sie diese Anweisungen für eine spätere Verwendung auf.
3. Befolgen Sie alle auf dem Produkt gekennzeichneten Warnungen und Anweisungen.
4. Trennen Sie dieses Produkt vor der Reinigung von der Wandsteckdose ab. Verwenden Sie keine Flüssigreiniger oder Aerosolreiniger. Reinigen Sie das Gerät mit einem feuchten Tuch.
5. Verwenden Sie dieses Produkt nicht in der Nähe von Wasser.
6. Stellen Sie dieses Produkt nicht auf einem instabilen Rack, Wagen, Ständer oder Tisch auf. Das Produkt könnte unter Umständen herunter fallen und ernsthafte Beschädigungen davontragen.
7. Dieses Produkt sollte von der auf dem Leistungsaufkleber aufgeführten Spannungsquelle betrieben werden. Wenn Sie nicht sicher sind, welche Spannung verfügbar ist, wenden Sie sich an Ihren Händler oder an Ihr örtliches Energieversorgungsunternehmen.
8. Dieses Gerät ist mit einem 3-adrigen Erdungsstecker ausgestattet - einem Stecker mit einem dritten (Erdungs-) Stift. Dieser Stecker passt nur in eine Erdungssteckdose. Hierbei handelt es sich um eine Sicherheitseinrichtung. Wenn sich der Stecker nicht in die Steckdose einstecken lässt, beauftragen Sie bitte einen Elektriker mit dem Austausch Ihrer veralteten Steckdose. Machen Sie den Zweck des Erdungssteckers nicht zunichte.
9. Lassen Sie keinerlei Gegenstände auf dem Netzkabel stehen. Stellen Sie dieses Produkt nicht an einem Ort auf, an dem Personen über das Kabel laufen würden.
10. Stellen Sie bei der Verwendung eines Verlängerungskabels sicher, dass die Gesamtleistung der an das Verlängerungskabel angeschlossenen Geräte nicht die Amperereistung des Verlängerungskabels überschreitet. Stellen Sie darüber hinaus sicher, dass alle an die Wandsteckdose angeschlossenen Geräte 15 Ampere nicht überschreiten.
11. Schieben Sie keinerlei Gegenstände über die Gehäuseschlitze in dieses Produkt, da diese gefährliche Spannungspunkte berühren oder Teile kurzschließen könnten. Beides könnte sowohl einen Brand als auch einen elektrischen Schlag zur Folge haben.
12. Versuchen Sie nicht, dieses Produkt selber zu warten, da Sie sich durch das Öffnen und Entfernen von Abdeckungen gefährlichen Spannungspunkten oder anderen Gefahren aussetzen würden. Überlassen Sie sämtliche Wartungsarbeiten dem Kundendienstpersonal.
13. Unter den nachfolgenden Umständen sollten Sie dieses Produkt von der Wandsteckdose abtrennen und qualifiziertem Kundendienstpersonal zur Wartung übergeben:
  - A. Wenn das Netzkabel oder der Stecker beschädigt oder abgenutzt sind.
  - B. Wenn Flüssigkeit in das Produkt gelangt ist.
  - C. Wenn das Produkt Regen oder Feuchtigkeit ausgesetzt worden ist.
  - D. Wenn das Gerät trotz Befolgen der Bedienungsanleitung nicht normal funktioniert. Stellen Sie nur die in der Bedienungsanleitung beschriebenen Regler ein, da eine falsche Einstellung anderer Regler Beschädigungen verursachen kann, und die Wiederherstellung des Normalbetriebes des Produktes durch einen qualifizierten Techniker einen hohen Arbeitsaufwand erforderlich machen würde.
  - E. Wenn das Gerät heruntergefallen ist oder das Gehäuse beschädigt wurde.
  - F. Wenn sich die Leistungsfähigkeit des Gerätes deutlich verändert, was ein Anzeichen dafür ist, dass eine Wartung erforderlich wird.
14. Die sich im Gehäuse, auf der Rückseite und der Unterseite des Gerätes befindlichen Schlitze und Öffnungen dienen der Ventilation und stellen einen zuverlässigen Betrieb des Produktes sicher. Darüber hinaus schützen sie das Gerät vor Überhitzung. Diese Öffnungen dürfen weder blockiert noch abgedeckt werden.

# Introduction

---

## About LKM-A121-B Tape Drive

The LKM-A121-B drive is a high capacity data storage device using Super Advanced Intelligent tape (S-AIT) technology. The LKM-A121-B drive achieves high data reliability through Read-After-Write, an additional level of Error Correction Code, and other features.

The LKM-A121-B drive stores data on tape using a standard format called S-AIT (Super Advanced Intelligent Tape) and ALDC (Adaptive Lossless Data Compression) formats.

# Introduction

## Product Features

	LKM-A121-B
Data Capacity	500 GByte uncompressed (with SAIT-1 600 m tape) 1300 GByte compressed * (with SAIT-1 600 m tape)
Transfer Rate (sustained)	30 MByte/s uncompressed 78 MByte/s compressed *

\* This is assuming 2.6 : 1 compression ratio.

### Product Features

- Supported Format : SAIT-1
- Not compatible with LTO, DLT and SDLT format tapes
- Burst Transfer – 200 MBytes/s
- 72 MByte Buffer Memory
- 5" form factor
- 2Gb Fibre Channel Interface
- Topology – Private Loop, Public Loop, Point-to-Point, Switched Fabric
- Transfers – Full-Duplex
- FCP2 Support
- Class of Service – Class 3
- Supports Variable or Fixed Record Length
- Read After Write (RAW) On and Off selectable
- Fragment Rewrite Function
- Three levels of Error Correction Code (ECC)
- High Speed Search
- Random Read, Append Write

---

## System Requirements

- FC Cable Requirements  
Transfer rate : 1 Gbit/s or 2 Gbit/s , Connector type : LC  
Transfer media : Optical-Multi mode, Short wave-length laser  
Cable length (Maximum) : 500 m (1 Gbit/s), 300 m (2 Gbit/s)  
Connecting Cable (Recommended) : ' FCLLM-xxx ' series  
(by Cybernetech)  
  
Note : FC = Fiber Channel
- FC Interface HBA Board (Recommended)  
' LSI40919 ' series (by LSI Logic)
- Cartridge-tape (Recommended)  
LKM-SA1-500 ( Panasonic )
- Cleaning Tape (Recommended)  
LKM-SA1-CL ( Panasonic )
- Backup Software (Recommended)  
' Brightstor ARCserve Backup v9 ' or ' Brightstor Enterprise Backup '  
(by Computer Associates)  
' NetVault ' (by BakBone Software)

Note : The actually System Requirements for backup depend on your using Backup software.  
For details, refer to the manual of each Backup software.

## Kit Contents ( attached )

- S-AIT Tape Drive Unit
- Power Cord ( Model LKM-A121-BC only )
- Installation Manual (this book)
- Filter Kit ( for Exchange )
- Cartridge-tape (1 pcs.)
- Cleaning Tape (1 pcs.)
- Warranty Card (with Registration Card)



---

## Precautions

### Installation

Avoid placing the drive in a location subject to:

- high humidity
- high temperature
- mechanical shock and vibration
- direct sunlight

### Operation

- Do not move the drive while it is operating. It may cause malfunction.
- Avoid exposing the drive to sudden changes from a low to high in temperature. This may cause water condensation to collect inside the drive. If the ambient temperature changes suddenly in transit, wait for more than four hours before turning on the drive. If you attempt to operate the drive immediately after a sudden increase in temperature, a malfunction may occur.
- Turning off the power to the drive while it is writing to tape may cause the tape to become unreadable. All previously negotiated parameters will be lost, whenever power to the drive is cycled.
- Upon execution of the hardware reset hole, the driver will be reset and there is a risk of lost and unreadable data. Thus, please do not use the hole other than repair purposes.

### Transportation

- Keep the original packing materials to facilitate transportation of the drive.
- Always remove the tape before moving the drive. After removing the drive from the computer, repack the drive into its original packing.
- After removing the SFP Fibre Channel Module from the drive and put the cap to it, repack them into its original packing.

# Parts and Functions

## Front View

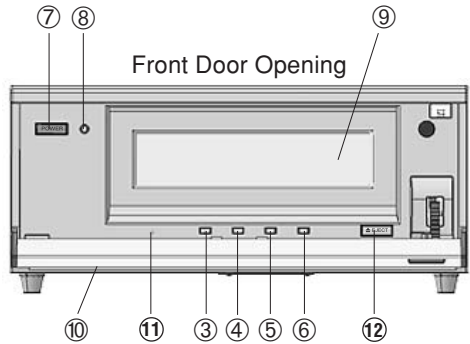
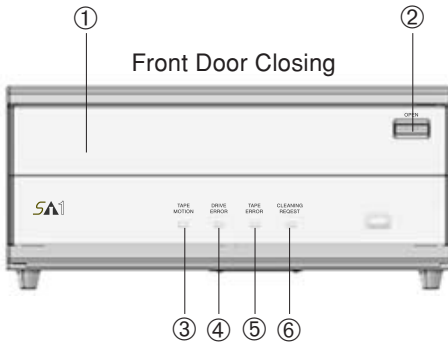

- ① **Front-Door**
- ② **Front-Door Button**  
Push the button to open the Front-Door
- ③ **Tape Motion LED \*1**  
Indicates the cartridge-tape operating status
- ④ **Drive Error LED \*1**  
Indicates the drive error status
- ⑤ **Tape Error LED \*1**  
Indicates the cartridge-tape error status
- ⑥ **Cleaning Request LED**  
Indicates the cleaning request status
- ⑦ **Power ON/OFF Switch**
- ⑧ **Power LED**  
Lights up "Green" when the Tape Drive Unit is ON
- ⑨ **Cartridge-tape Inserting Door**
- ⑩ **Air Flow Hole ( for absorption )**  
Not be blocked or covered to protect this Library from overheating
- ⑪ **Hard Reset Hole**  
Hole for maintenance ( Not use generally )
- ⑫ **Eject Button**  
Takes out the cartridge-tape

\*1) For details of each LED indication status, refer to 'LED Indication for Drive Status' in page 27.

---

## Rear View

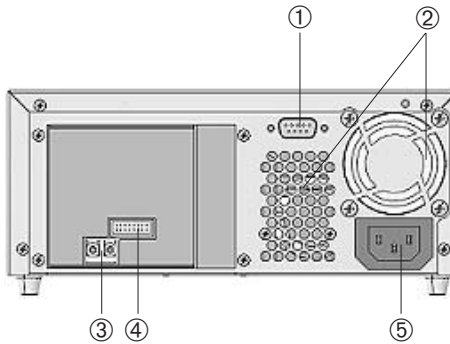

① **Connector for maintenance**

Not use generally

② **Fan / Air Flow Hole ( for release )**

Not be blocked or covered to protect this Library from overheating

③ **Fibre Channel Connector**

Connect the Fibre Channel interface cable.

Note: In advance, put the SFP Fibre Channel Module (attached) into the drive unit.

④ **Jumper**

Sets LOOP ID, parity-check, etc.

For details of each jumper setting, refer to 'FC Connection/Setting the LOOP ID' in next page.

⑤ **Power Connector**

Connect the power cord

# Installation

## FC Connection/Setting the LOOP ID

### LOOP ID

LOOP ID	6	5	4	3	2	1	0
0	■	■	■	■	■	■	■
1	■	■	■	■	■	□	□
2	■	■	■	■	■	□	■
3	■	■	■	■	■	□	□
4	■	■	■	■	■	■	■
5	■	■	■	■	■	□	□
6	■	■	■	■	■	■	■
⋮							
121	□	□	□	□	■	■	□
122	□	□	□	□	■	■	■
123	□	□	□	□	■	■	□
124	□	□	□	□	■	■	■
125	□	□	□	□	■	■	■
Reserved	□	□	□	□	□	■	■
Reserved	□	□	□	□	□	□	□

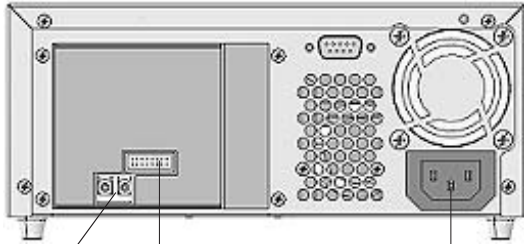

FC Connector

Power Connector

### Jumpers

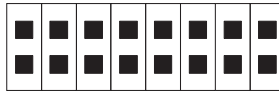

- LOOP ID Enable
- LOOP ID 6
- LOOP ID 5
- LOOP ID 4
- LOOP ID 3
- LOOP ID 2
- LOOP ID 1
- LOOP ID 0

### LOOP ID

Enable	□	□	□	□	□	□	□
Disable	■	□	□	□	□	□	□

Note : □ = CLOSED/Jumper  
 ■ = OPEN/Jumper not installed

## Loop ID Jumper

This jumper is functional when the topology is arbitrated loop. When this jumper is enabled, it gains AL\_PA by LIHA (Loop Initialization Hard Assigned). AL\_PA is gained from loop ID. Refer to the table Arbitrated Loop Physical Addresses (AL\_PA) and Loop IDs as the conversion rule. When this jumper is disabled, requiring AL\_PA by LIHA is not executed, and AL\_PA is gained from LISA (Loop Initialization Soft Assigned).

## Arbitrated Loop Physical Addresses (AL\_PA) and Loop IDs

7-bit Loop ID (Hex) (Decimal)		8-bit AL_PA (Hex)	7-bit Loop ID (Hex) (Decimal)		8-bit AL_PA (Hex)	7-bit Loop ID (Hex) (Decimal)		8-bit AL_PA (Hex)	
lowest priority	00	0	EF	2B	43	A3	56	86	4D
	01	1	E8	2C	44	9F	57	87	4C
	02	2	E4	2D	45	9E	58	88	4B
	03	3	E2	2E	46	9D	59	89	4A
	04	4	E1	2F	47	9B	5A	90	49
	05	5	E0	30	48	98	5B	91	47
	06	6	DC	31	49	97	5C	92	46
	07	7	DA	32	50	90	5D	93	45
	08	8	D9	33	51	8F	5E	94	43
	09	9	D6	34	52	88	5F	95	3C
	0A	10	D5	35	53	84	60	96	3A
	0B	11	D4	36	54	82	61	97	39
	0C	12	D3	37	55	81	62	98	36
	0D	13	D2	38	56	80	63	99	35
0E	14	D1	39	57	7C	64	100	34	
	0F	15	CE	3A	58	7A	65	101	33
	10	16	CD	3B	59	79	66	102	32
	11	17	CC	3C	60	76	67	103	31
	12	18	CB	3D	61	75	68	104	2E
	13	19	CA	3E	62	74	69	105	2D
	14	20	C9	3F	63	73	6A	106	2C
	15	21	C7	40	64	72	6B	107	2B
	16	22	C6	41	65	71	6C	108	2A
	17	23	C5	42	66	6E	6D	109	29
	18	24	C3	43	67	6D	6E	110	27
	19	25	BC	44	68	6C	6F	111	26
	1A	26	BA	45	69	6B	70	112	25
	1B	27	B9	46	70	6A	71	113	23
	1C	28	B6	47	71	69	72	114	1F
	1D	29	B5	48	72	67	73	115	1E
	1E	30	B4	49	73	66	74	116	1D
	1F	31	B3	4A	74	65	75	117	1B
	20	32	B2	4B	75	63	76	118	18
	21	33	B1	4C	76	5C	77	119	17
	22	34	AE	4D	77	5A	78	120	10
	23	35	AD	4E	78	59	79	121	0F
	24	36	AC	4F	79	56	7A	122	08
	25	37	AB	50	80	55	7B	123	04
	26	38	AA	51	81	54	7C	124	02
	27	39	A9	52	82	53	7D	125	01
	28	40	A7	53	83	52	–	–	–
	29	41	A6	54	84	51	–	–	–
	2A	42	A5	55	85	4E	–	–	–

highest priority

## Option Switches ( DIP Switch )

The dip switches locate on the bottom of this drive.  
( Not operate these switches generally. )

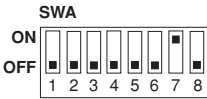

SWA Setting

SW1	Reserved	OFF
SW2	Reserved	OFF
SW3	Reserved	OFF
SW4	Reserved	OFF
SW5	Reserved	OFF
SW6	Reserved	OFF
SW7	DC Control-1	ON
SW8	DC Control-2	OFF

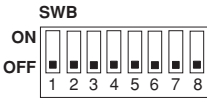

SWB Setting

SW1	Reserved	OFF
SW2	Reserved	OFF
SW3	Reserved	OFF
SW4	Reserved	OFF
SW5	Reserved	OFF
SW6	Reserved	OFF
SW7	Reserved	OFF
SW8	Reserved	OFF

## Connecting

After make sure that the system (Host PC) power switch is OFF, please connect the S-AIT drive unit as follows.

- 1) Connect the Fibre Channel interface cable to the drive unit.
- 2) Connect the other end of the Fibre Channel interface cable to the system (host PC) Fibre Channel connector.
- 3) Connect the power cord to the drive unit and the outlet with earth, and turn the drive unit power ON.
- 4) Turn the system (host PC) power ON.

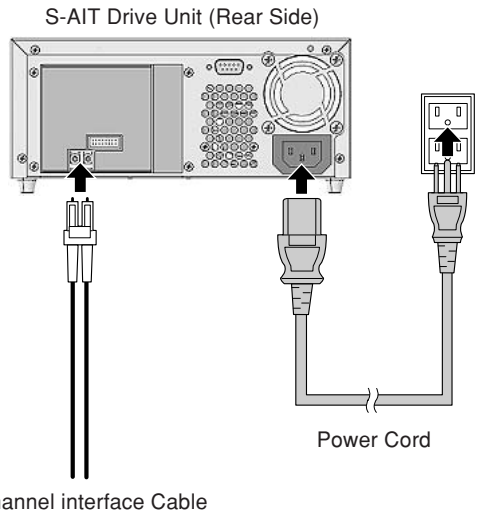

# Operation ( for Model LKM-A111-BC / LKM-A111-BD / LKM-A121-BC / LKM-A121-BD )

## LED Indication for Drive Status

The LED indicators are defined as follows

LED	TAPE MOTION	DRIVE ERROR	TAPE ERROR	CLEANING REQUEST
GREEN, ALL lit (0.5 sec.) then YELLOW blinks from left LED to right LED repeatedly. (during Diag for 2 to 3 sec.)	A Moment of Power ON and Reset			
ALL GREEN, blinking	Firmware Update			
GREEN, ALL lit only while Eject Button is pressing	Eject Inhibit			
UMBER, blinking	Tape Access in Progress (Write)	Drive Error Occured	Media Error Occured	Error on Cleaning
UMBER			Media Error Occured	
YELLOW, blinking	Tape Access in Progress (Search)	Drive Error Occured	Media Warning	Cleaning Request
YELLOW	Tape Loaded (Write Protected)			Cleaning is Not Completed
GREEN, blinking	Tape Access in Progress (Read)			
GREEN	Tape Loaded (Writable)			
OFF	No Tape	No Drive Error Occured	No Media Error Occured	No Cleaning Request Occured

Power LED [GREEN] : lit = Power ON, blinking = FAN is malfunction

---

## Drive Operation

### About the Cartridge Tapes

To avoid condensation onto the cartridge, the Library and cartridge must be kept away from quick fluctuation (15 deg/ hr) in temperature. If the ambient temperature changes suddenly, leave around 12 hours in suitable environment before you use it again.

Life extension period of cartridge tape depends on environmental condition, usage and cleaning cartridge tape. We recommend back up act less than 300 times and to exchange new cartridge tape as soon as you are aware of failure.

### Loading a Cartridge-tape

Insert a cartridge-tape into the cartridge-tape inserting door on the front panel with the arrow on the cartridge-tape pointing towards the drive. As the Cartridge-tape is inserted, the drive takes it and automatically loads it into drive mechanism.

### Unloading a Cartridge-tape

The cartridge-tape can be removed from the drive unit either in response to a SCSI Unload Command, or by pressing the eject button.

By pressing Eject button, the drive ejects the cartridge-tape from the cartridge-tape inserting door.

### Write-protecting a Cartridge-tape

Cartridge-tapes can be write-protected by sliding the tab on the back of the cartridge-tape. In this state, data can be read from the tape but not written onto it.

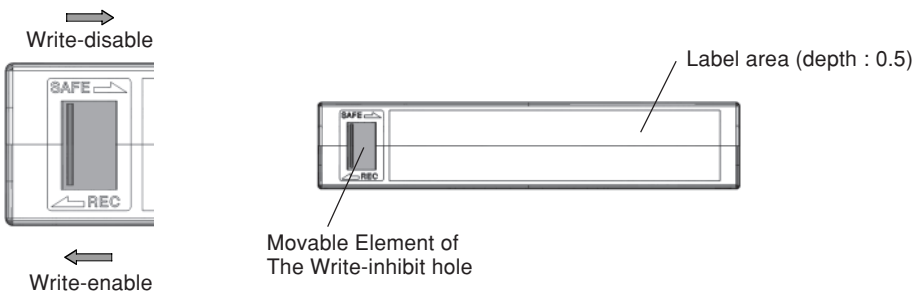

### Using a Cleaning Tape

In case of the drive unit, a cleaning function is built in the drive and hence, a periodic cleaning using cleaning tape such as other format requires is not necessary. However, when the drive does not recover at the worst case, cleaning tape is recommended to use.

Note : For details of cleaning tape, refer to " System Requirements " in Page 20.



# Interface Implementation

( for Model LKM-A111-BC / LKM-A111-BD / LKM-A121-BC / LKM-A121-BD )

---

## Supported SCSI Messages

Abort	Message Parity Error
Bus Device Reset	Message Reject
Command Complete	No Operation
Disconnect	Restore Pointers
Extended Message	Save Data Pointer
- Synchronous Data Transfer Request	
- Wide Data Transfer Request	
Identify ( w/&w/o Disconnect )	
Ignore Wide Residue	

---

## Supported SCSI Commands

Erase	Report Density Support
Inquiry	Report Luns
Load/Unload	Request Block Address
Locate	Request Sense
Log Sense	Reserve Unit
Log Select	Rewind
Mode Select	Seek Block
Mode Sense	Send Diagnostic
Prevent Allow Medium Removal	Space
Read	Test Unit Ready
Read Block Limits	Verify
Read Buffer	Write
Read Position	Write Buffer
Receive Diagnostic Result	Write Filemarks
Release Unit	

# Maintenance

( for Model LKM-A111-BC / LKM-A111-BD / LKM-A121-BC / LKM-A121-BD )

---

We recommend to maintain periodically the drive and the cartridge-tape to use safely and comfortably.

When maintaining, please take care the below contents.

- Keep the cartridge-tape away from direct sunlight, high temperature, and high humidity place.  
If it is not, it may result in the data destroy.
- Do not touch on the tape surface.  
If touch it, it may result in the data destroy.  
If touch it to soil, it may be impossible to write/read data normally.
- Do not clean with chemical or cleanser.  
If use chemical or cleanser (static guard, etc.), it may result in the data destroy or a malfunction.
- Do not paste paper or label, etc.  
If paste, it may result in the data destroy or a malfunction.
- Do not drop or bend the cartridge-tape, or do not take out the tape in the cartridge.  
If the tape crack or transform, it may be impossible to write/read data normally.
- When the drive dirt is cruel.  
Do not clean the drive with benzine or thinner, etc.  
If do it, it may result in change in the plastic quality or the paint coming off on the drive cabinet.  
When use the chemical duster, follow the notice writing of it.  
Please clean the dirt with soft cloth dipped by water or kitchen-cleanser(synthetic) and squeezed firmly.

## Filter Exchanging

The Filter is attached on the Air Flow Hole in bottom of the drive unit.  
We recommend to exchange the Filter about one time in a year as following steps.

### Filter Removing

- 1) Push the tub in left end of the Filter attached to the Air Flow Hole to unlock.
- 2) Slide the Filter to left (arrow) direction to unlock the Center Lock.
- 3) Remove the Filter from the drive unit.

When the Center Lock is unlocked, the Right End Lock is unlocked at the same time, and then the all Filter is removed.

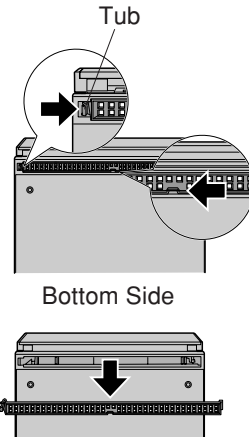

### Filter Attaching

- 1) Prepare a new Filter.
- 2) Slide the Filter to right (arrow) direction with sheet side pointing to the drive unit to lock the Center Lock.

Lock also the right end of the Filter locking the center portion.

- 3) Push the tub in left end of the Filter to right (arrow) direction to attached the Filter to the drive unit.

Lock securely by the tub in left end of the Filter.

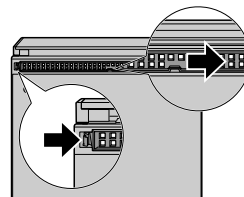
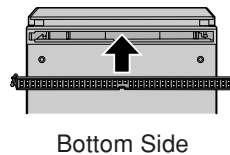

# Specification

( for Model LKM-A111-BC / LKM-A111-BD / LKM-A121-BC / LKM-A121-BD )

## Cartridge Tape Performance

Data Capacity (S-AIT1 / 600 m) \*1      500 GByte ( compression mode : 1300 GByte )

Transfer Rate (S-AIT1) \*2                      30 MByte/s ( compression mode : 78 GByte/s )

Note :

\*1 ) Compression Rate = 2.6 x ( Compression Rate is changed with data type.)

\*2 ) Transfer Rate may be different with system(host PC) performance.

## General Performance

Search Time (average)	70 s
Interface	Ultra 160 Wide LVD/SE SCSI (LKM-A111-B) 2 GByte/s Fiber-Channel (LKM-A121-B)
Buffer Memory	72 MByte
Error Rates	Less than $10^{-17}$
Power Rating	100 – 240 V ~ AUTO 0.7 – 0.4 A    50 / 60 Hz
Dimensions (W x H x D)	210 x 86 x 370 mm
Weight	6.7 kg [ typical ]

## Environmental Conditions

	<i>Operating</i>	<i>Non-operating</i>
• Temperature	5 ~ 35 °C	– 40 ~ 70 °C (No cartridge-tape)
• Humidity	20 ~ 80 %Rh (Non-condensation)	5 ~ 95 %Rh (Non-condensation)

Installation : Horizontal

## Mounting the Drive Unit to Rack

- 1) If you need the Rail (Rail-Bracket) or Angle for mounting to your rack, attach the suitable ones for the Rack / Drive unit to them.  
– For details of installing the Rail (Rail-Bracket) or Angle, refer to each manual for them.
- 2) Gently slide the Drive unit into the vacant rack part, and secure it with the mounting screws as below figure.

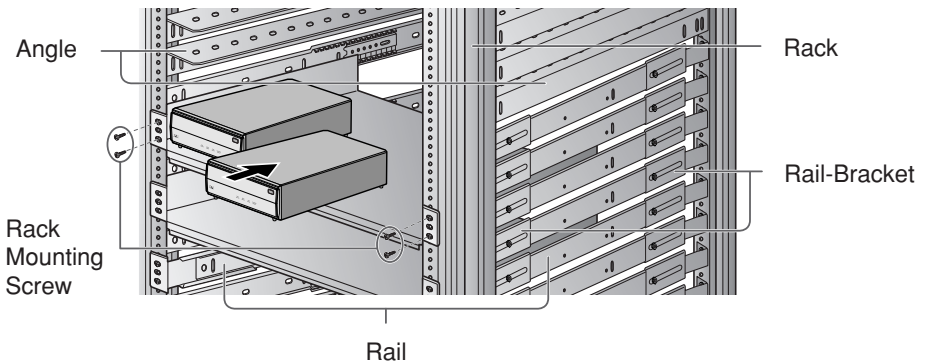

### Note :

Surely mount to horizontal direction.

The above equipments ( Angle/ Rail/ Rail-Bracket/ Screw ) are NOT included with this product.

## Montage

- 1) Wenn Sie für die Montage in Ihr Rack die Schiene (Schienenträger) oder den Winkel benötigen, befestigen Sie bitte das für das Rack / die Antriebseinheit passende Teil.  
– Einzelheiten zur Installation der Schiene oder des Winkels finden Sie im entsprechenden Handbuch.
- 2) Schieben Sie die Antriebseinheit behutsam in den freien Rackteil und sichern Sie sie - wie in der nachfolgenden Abbildung gezeigt - mit den Montageschrauben.

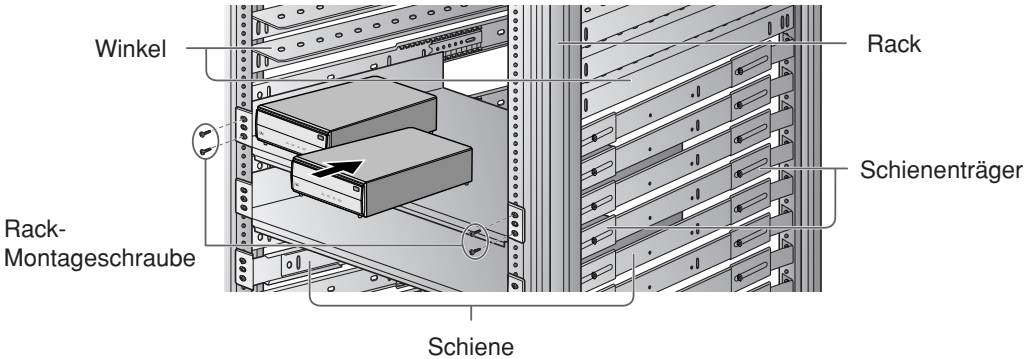

### Hinweis:

Führen Sie die Montage sicher in horizontaler Richtung durch.

Die oben aufgeführten Ausrüstungen (Winkel / Schiene / Schienenträger / Schraube) sind NICHT im Lieferumfang dieses Produktes enthalten.



Specifications are subject to change without notice.

LMQT00623

Printed in Japan

Rev. A